

❧ Book of Traceable Heraldic Art ❧

Volume 14:

Food

Including Cooking, Brewing,
Food Storage, Dishes & Utensils

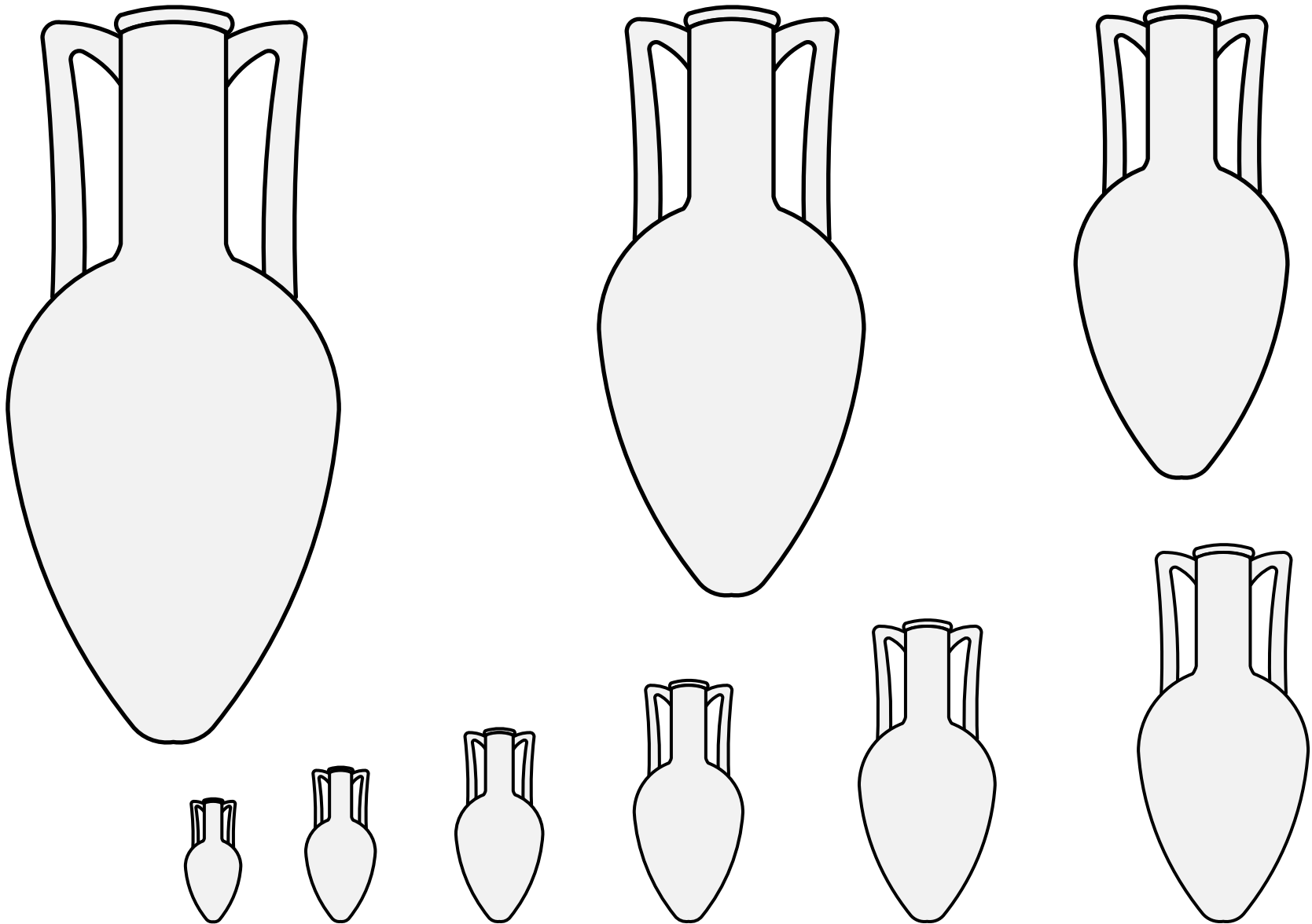

A tall jar for storage of wine or oil.

Default orientation: upright.

Source: Viking Answer Lady SVG Images For Heraldists. Artist: Gunnvôr silfrhárr.

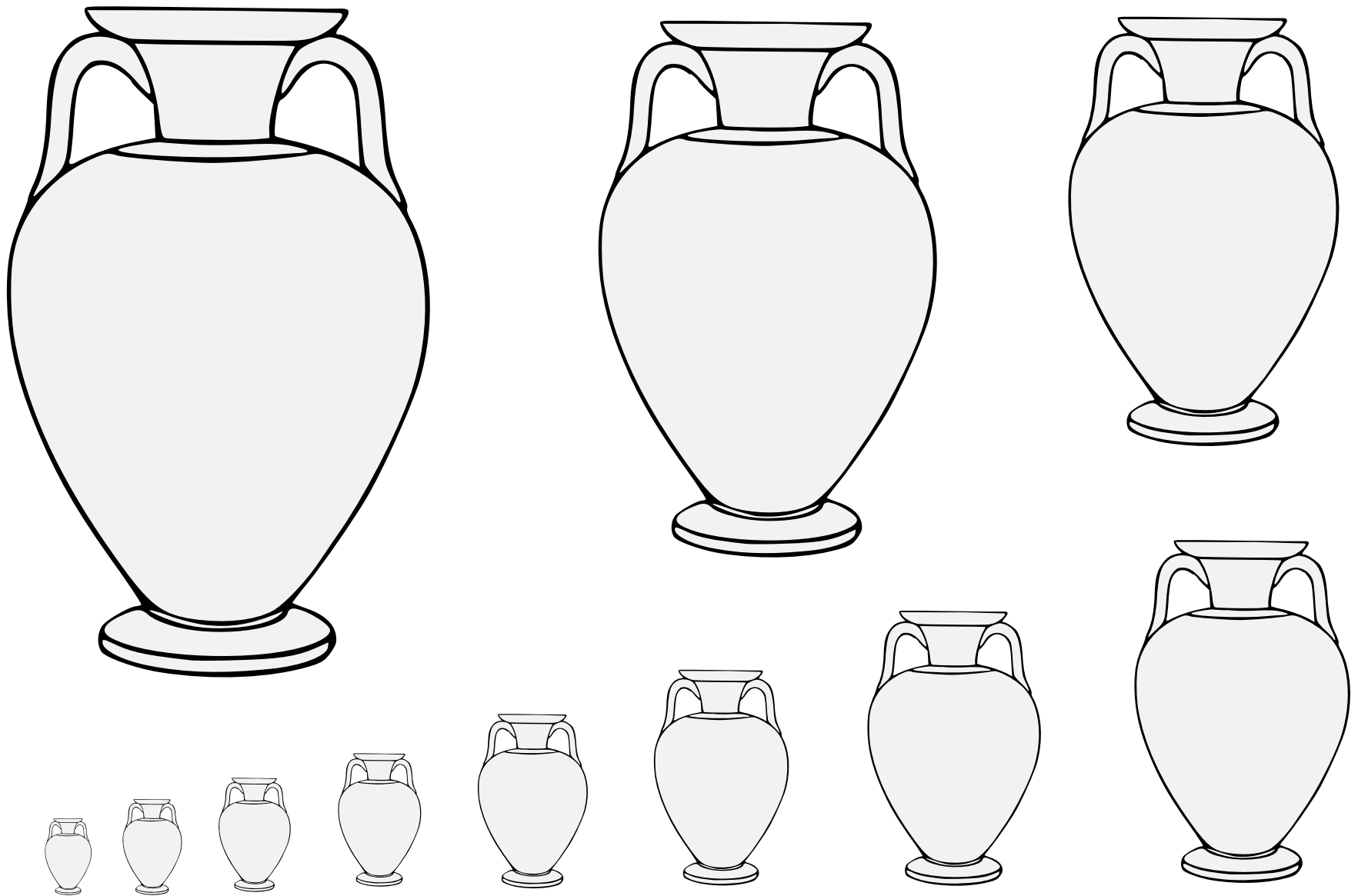

A tall jar for storage of wine or oil.

Default orientation: upright.

Source: The Principles of Design. Artist: George Woolliscroft–Rhead.

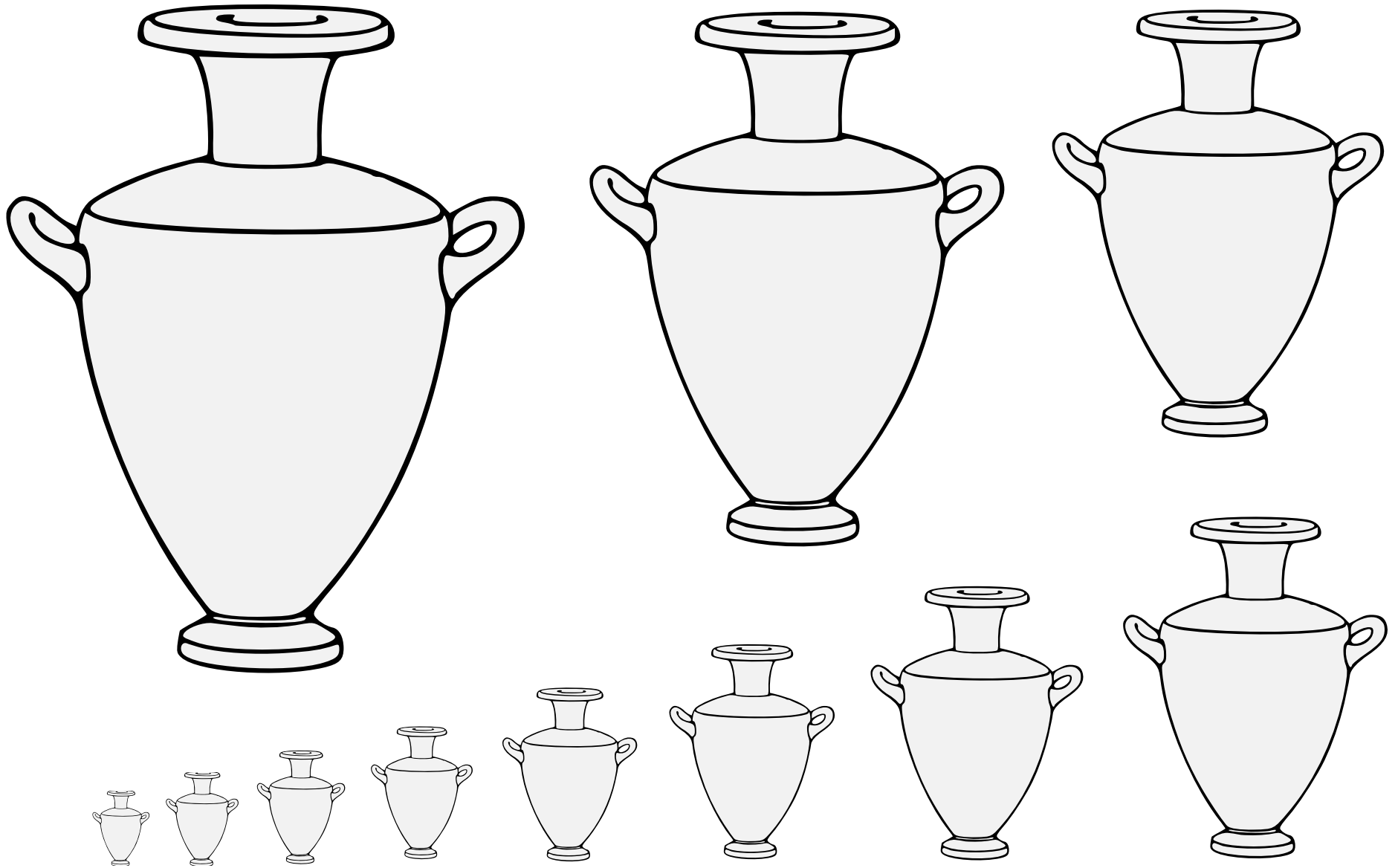

A tall jar for storage of wine or oil.

Default orientation: upright.

Source: The Principles of Design. Artist: George Woolliscroft-Rhead.

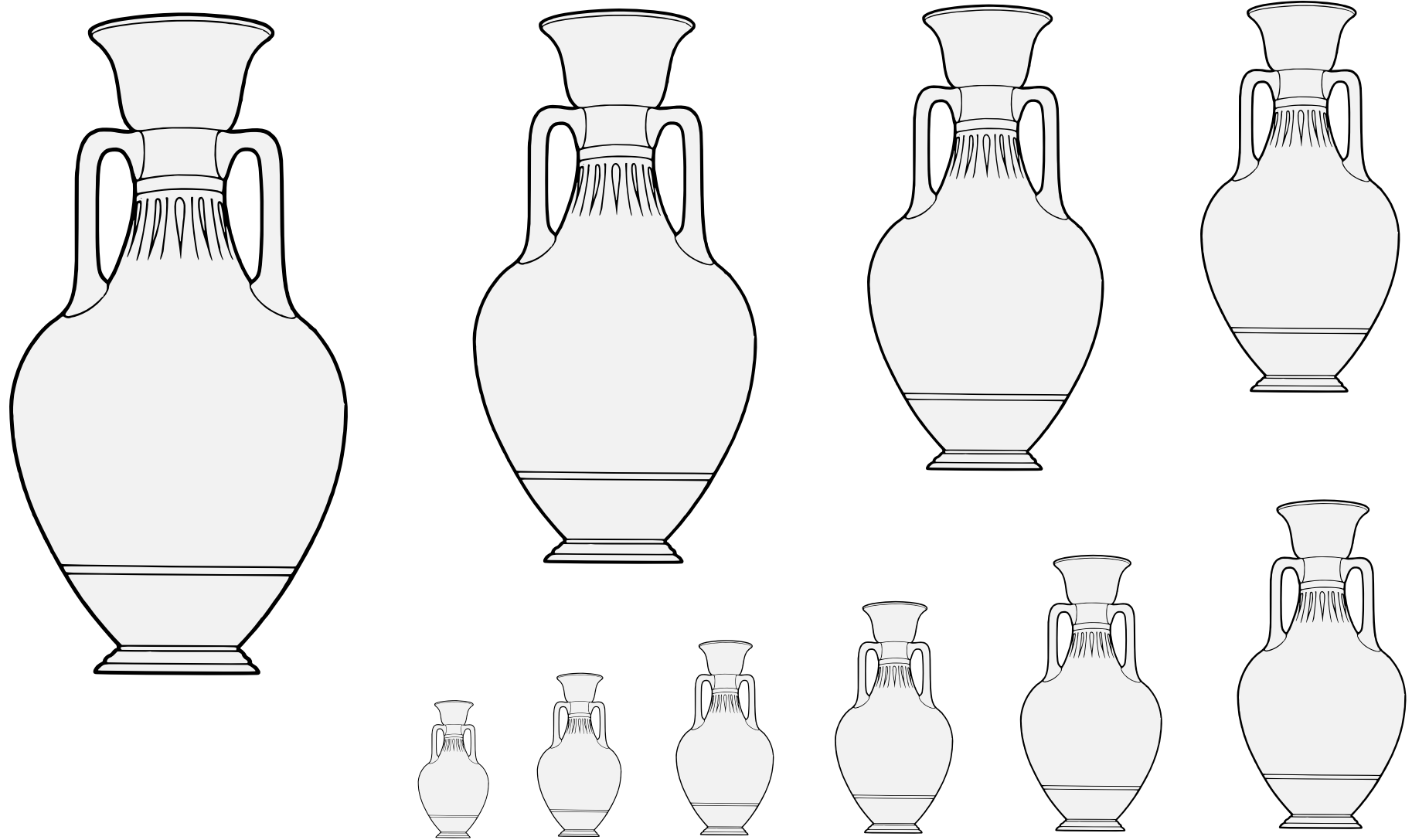

A tall jar for storage of wine or oil.

Default orientation: upright.

Source: Cusack's Freehand Ornament. (Plate 31.) Artist unknown.

Amphora (4) 14.5

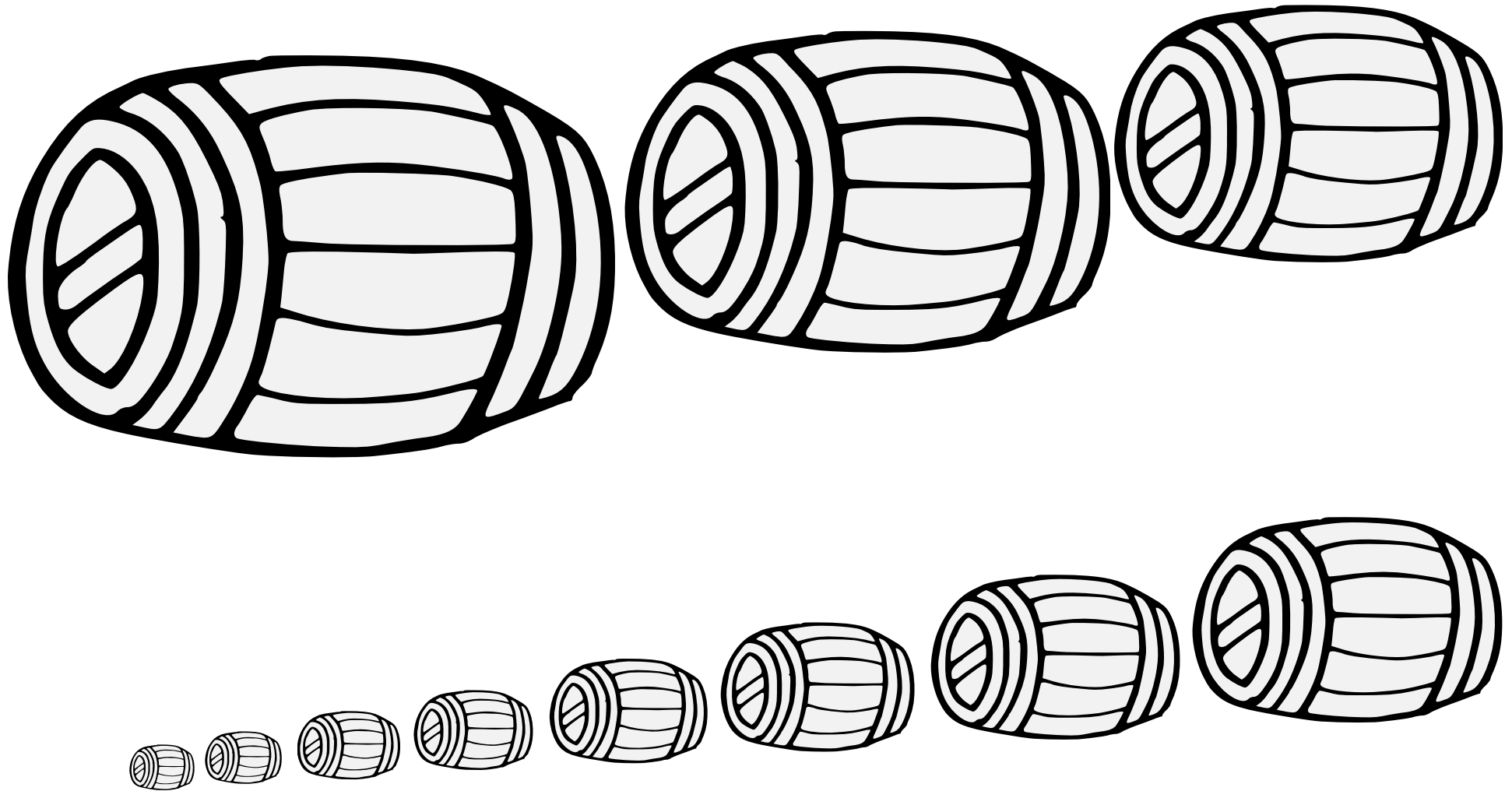

A cylindrical container for liquids.

Default orientation: fesswise. Proper coloration: brown wood.

Source: Banners, Standards, and Badges. Artist: Thomas Willement.

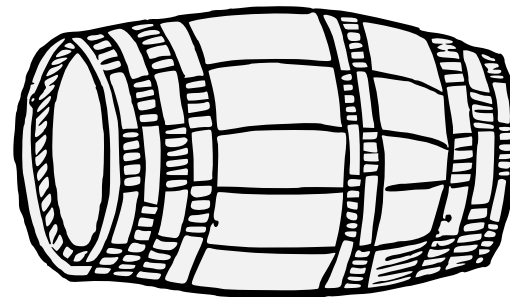
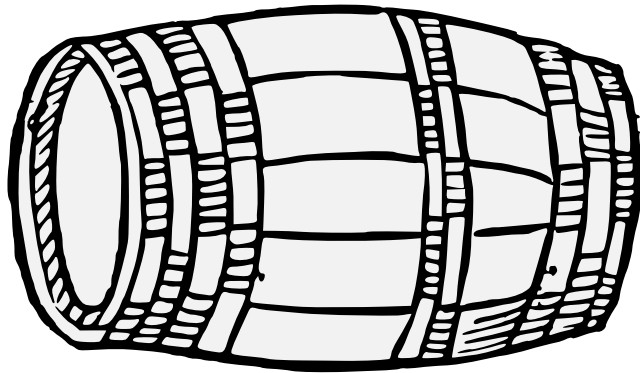
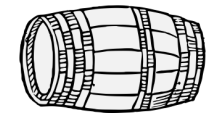
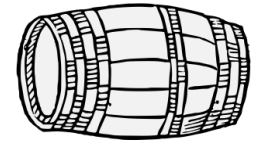
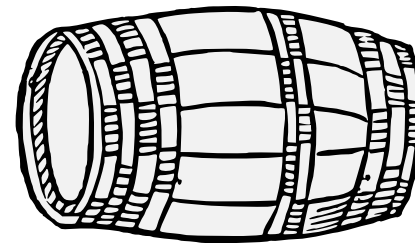
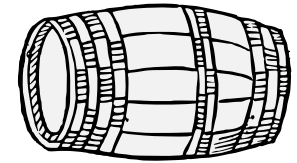
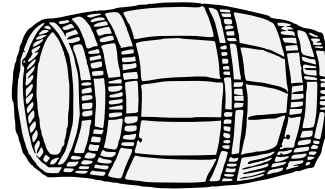
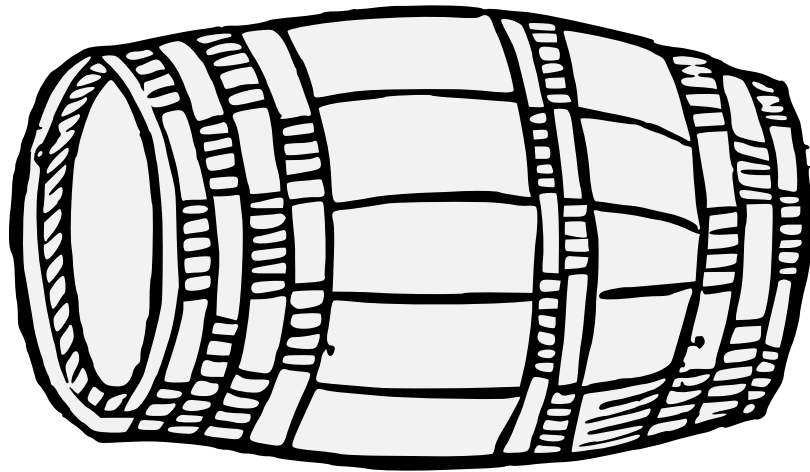

A cylindrical container for liquids.

Default orientation: fesswise. Proper coloration: brown wood.

Source: Ortus Sanitatis. Artist unknown.

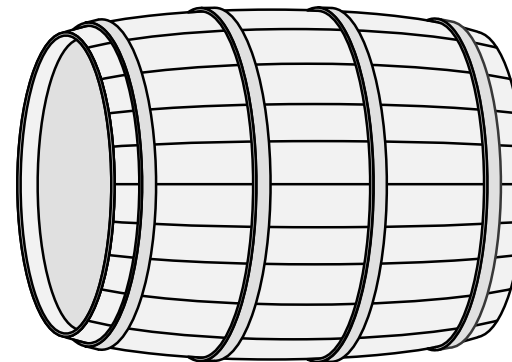
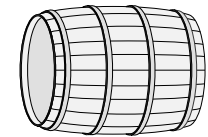
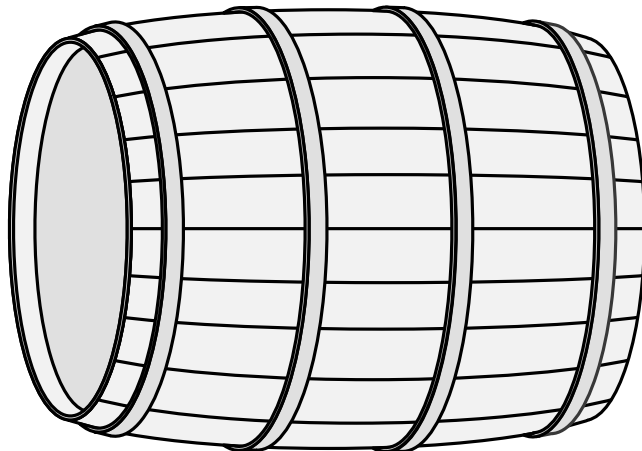
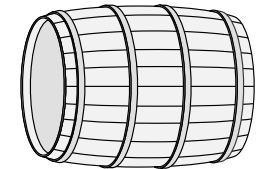
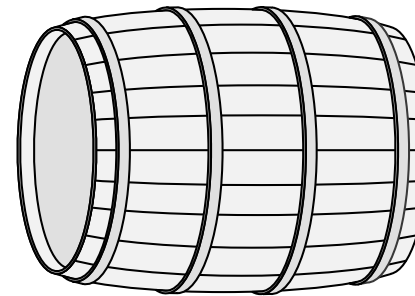
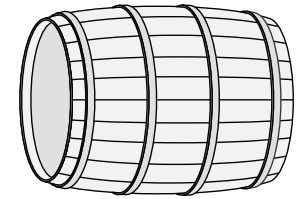
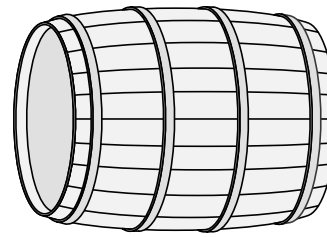
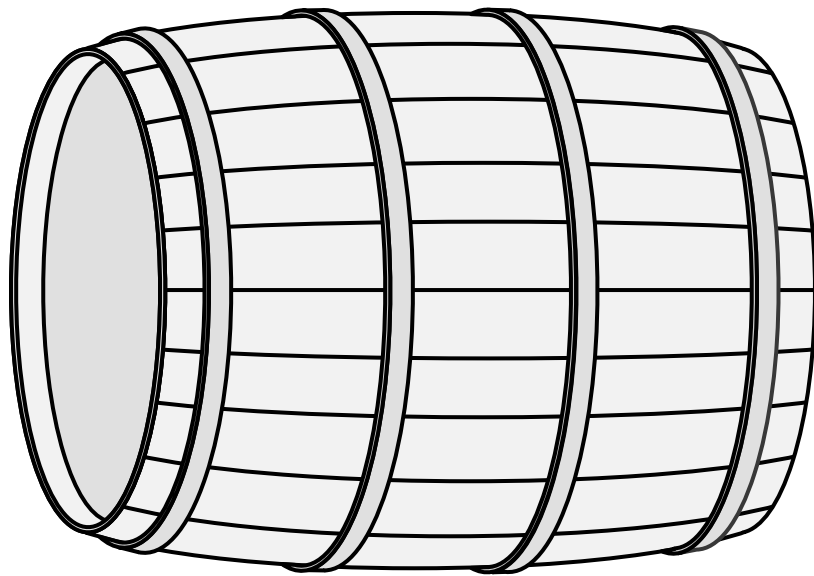

A cylindrical container for liquids.

Default orientation: fesswise. Proper coloration: brown wood.

Barrel (3) 14.8

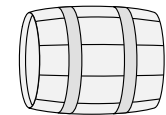
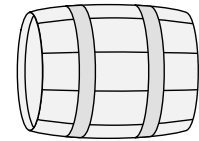
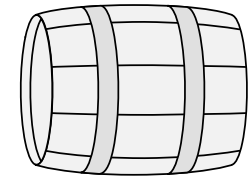
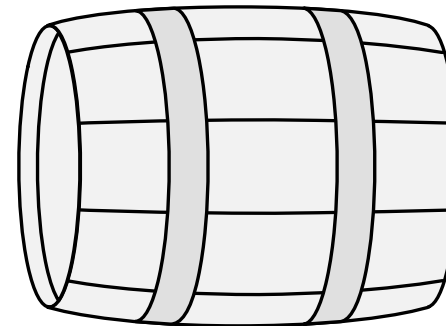
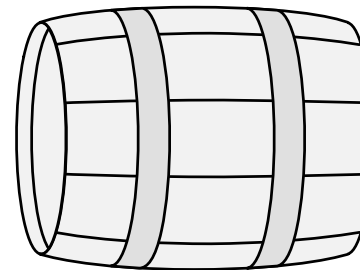
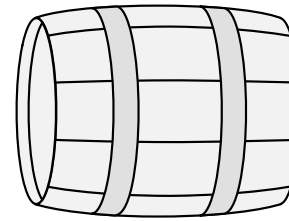
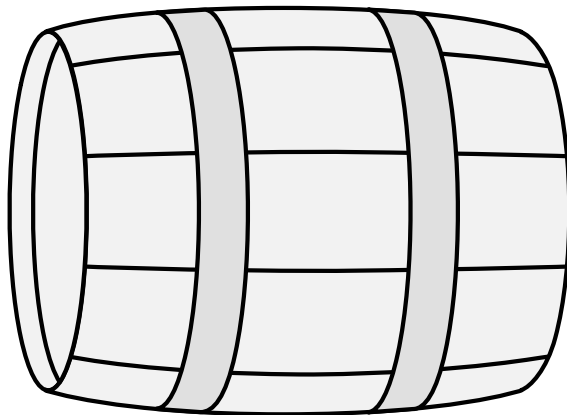
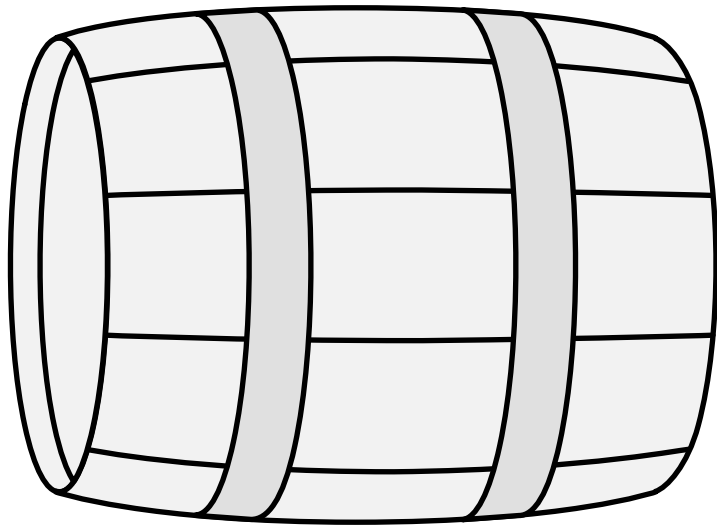

A cylindrical container for liquids.

Default orientation: fesswise. Proper coloration: brown wood.

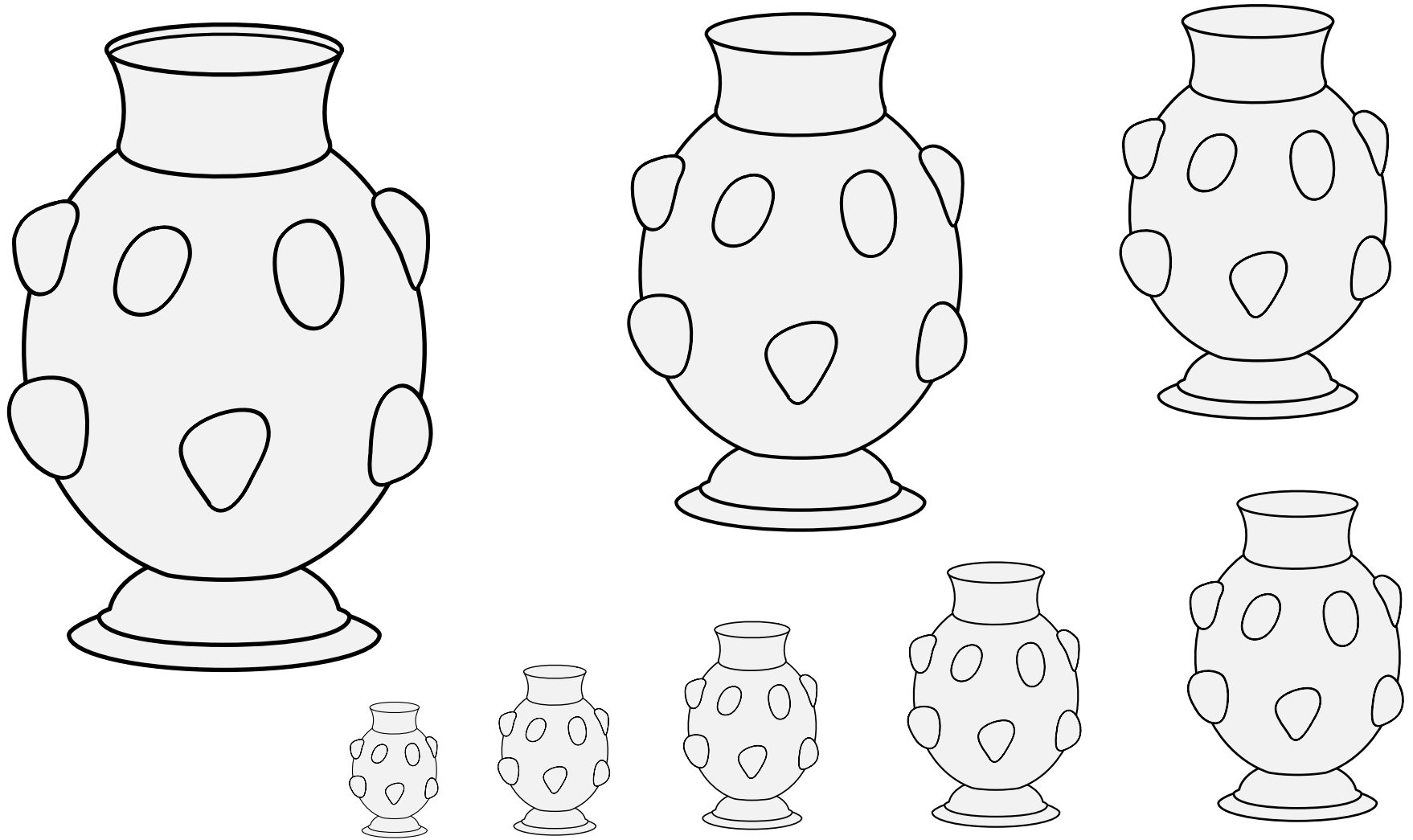

A glass drinking vessel.

Default orientation: upright. No proper coloration.

The term "pruned" indicates that the surface of the item is covered with small knobs of glass which both decorate it and make it easier to grip.

Source: Siebmacher's Wappenbuch of 1605. Artist: Johann Siebmacher. (Arms of Escher vom Glas, page 199.)

Beaker, Pruned (1) 14.10

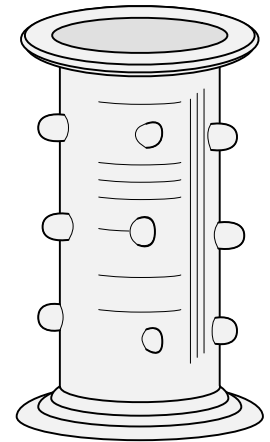
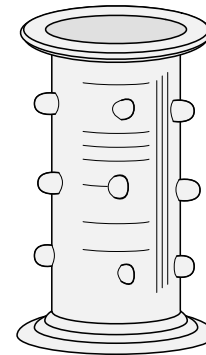
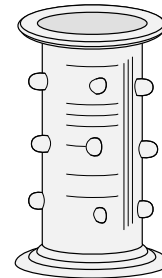
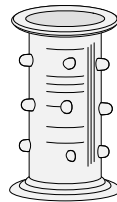
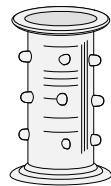
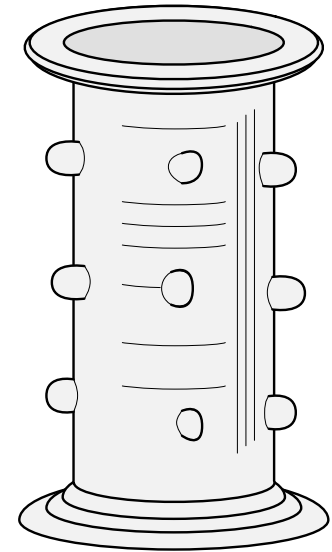
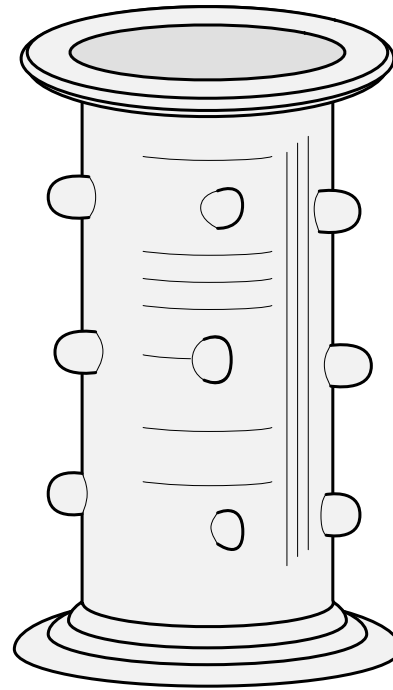
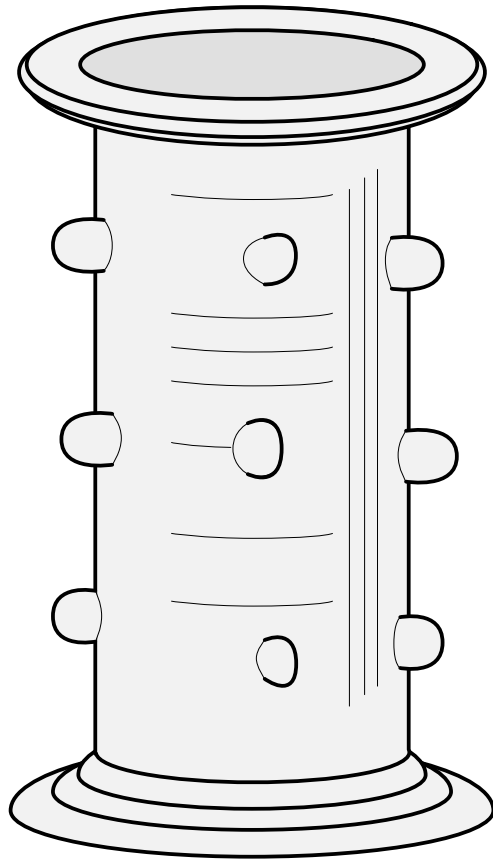

A glass drinking vessel.

Default orientation: upright. No proper coloration.

The term "prunted" indicates that the surface of the item is covered with small knobs of glass which both decorate it and make it easier to grip.

Source: Wappenbuch der Arlberg-Bruderschaft.
Artist: Vigil Raber. (From page 265.)

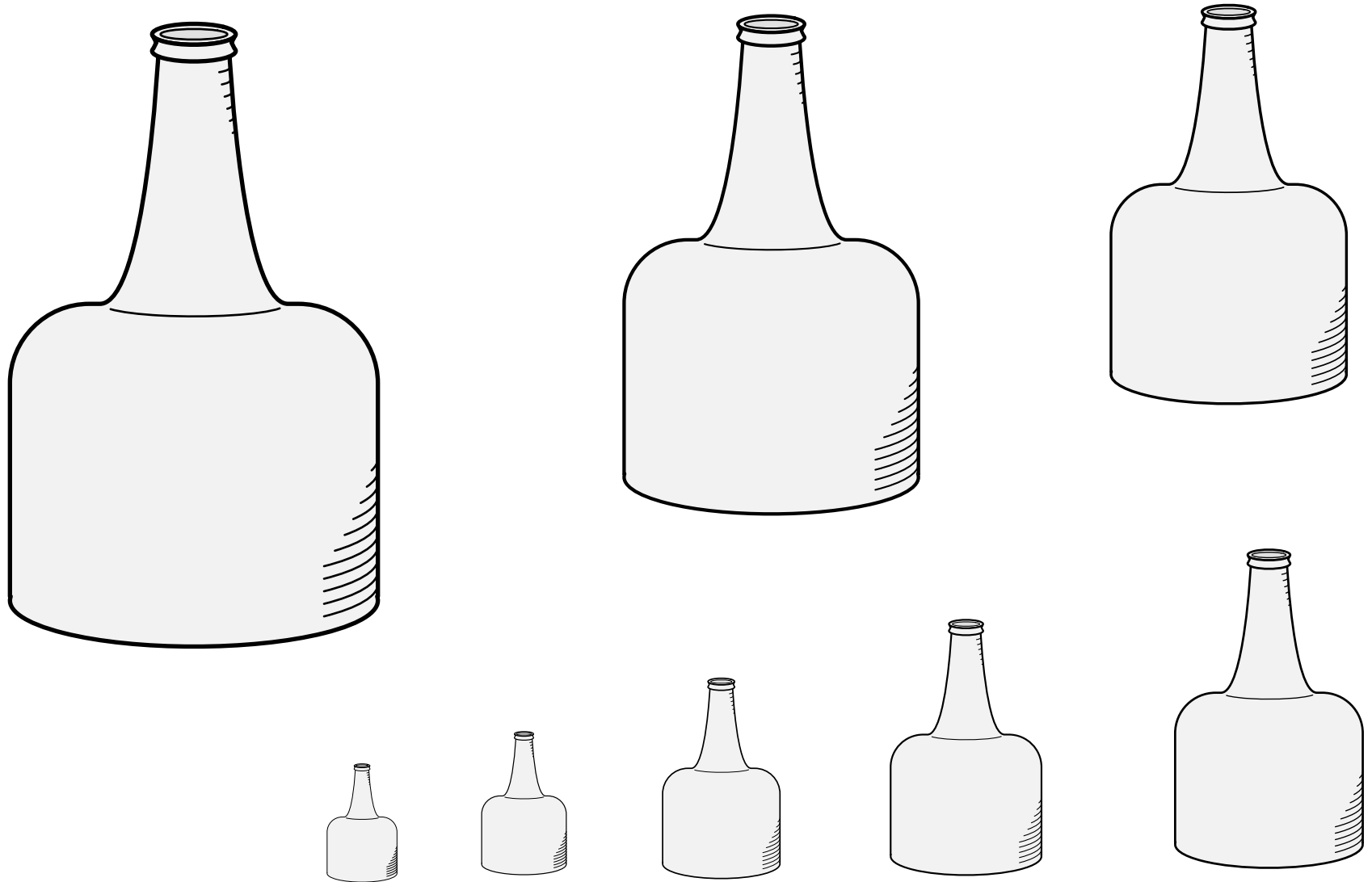

A portable container for water or wine.

Default orientation: upright. No proper coloration.

Adapted from photographs of sixteenth-century wine bottles.

Bottle (1) 14.12

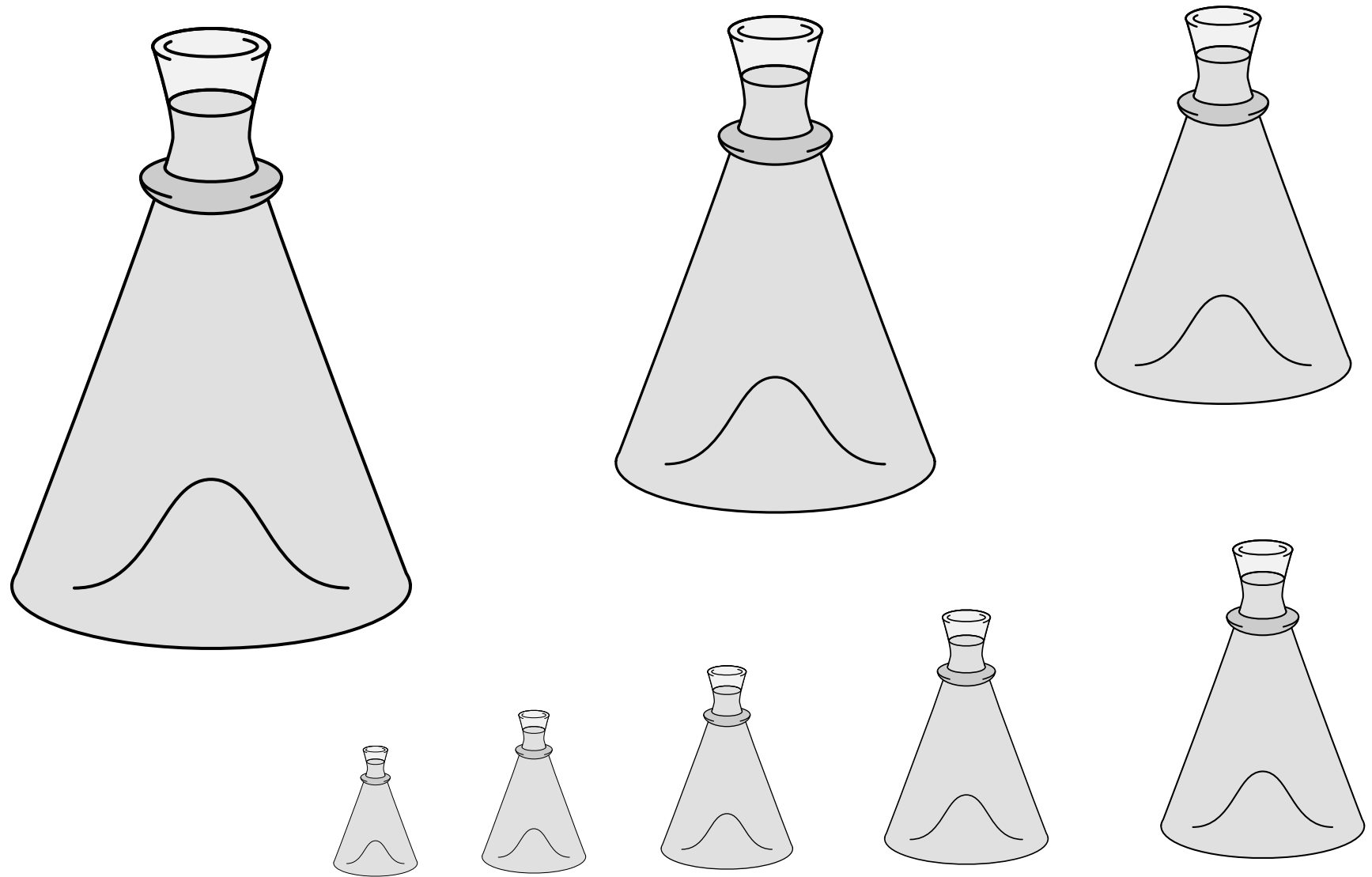

A portable container for water or wine.

Default orientation: upright. No proper coloration.

Source: Stemmario Trivulziano. Artist: Gian Antonio da Tradate.
(Arms of de Muschiaro, p 223.)

Bottle (2) 14.13

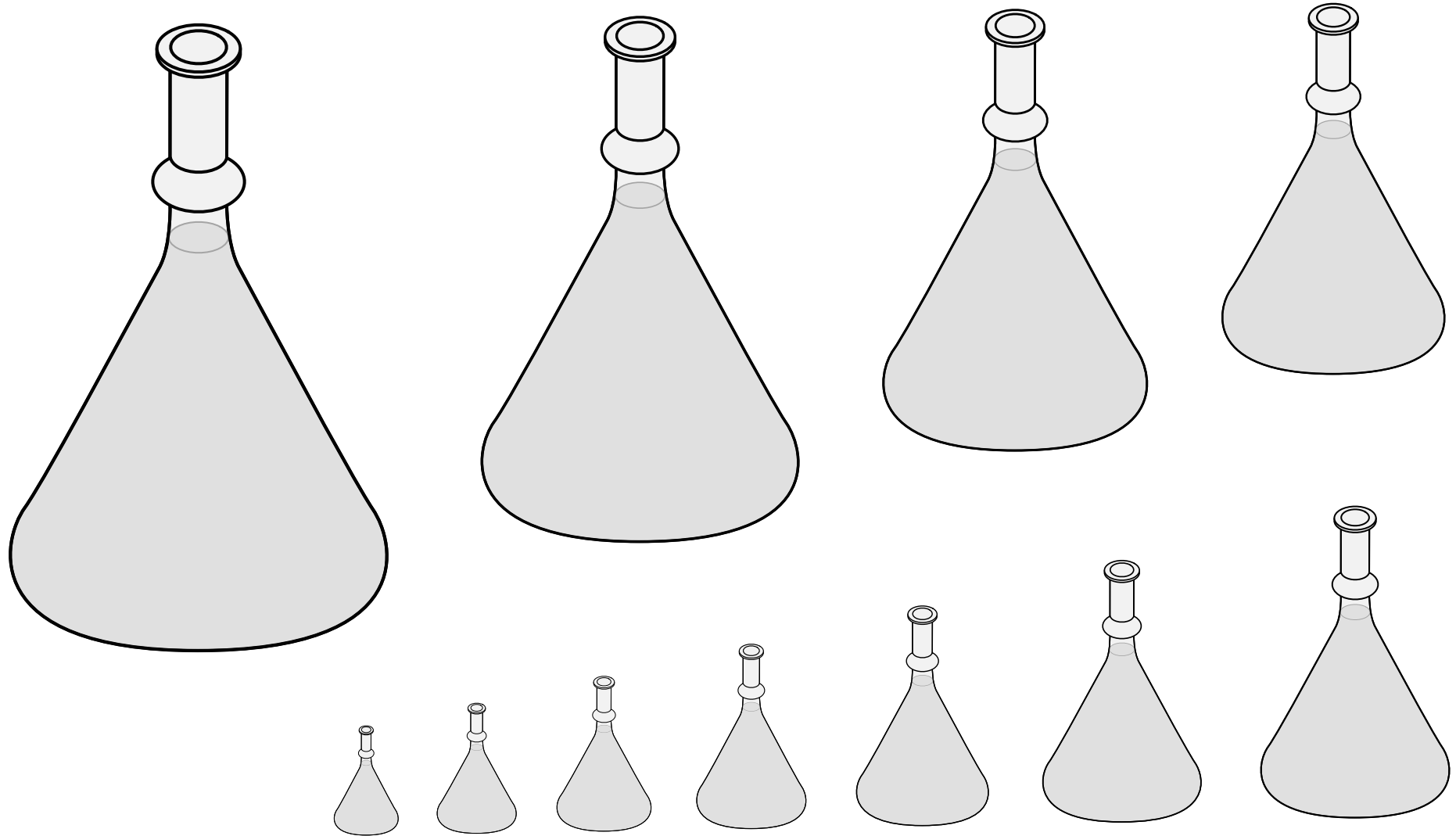

A portable container for water or wine.

Default orientation: upright. No proper coloration.

Source: A painting in the church of San Marcello di Paruzzaro, depicting the Master of the Passion of Postua. Artist unknown.

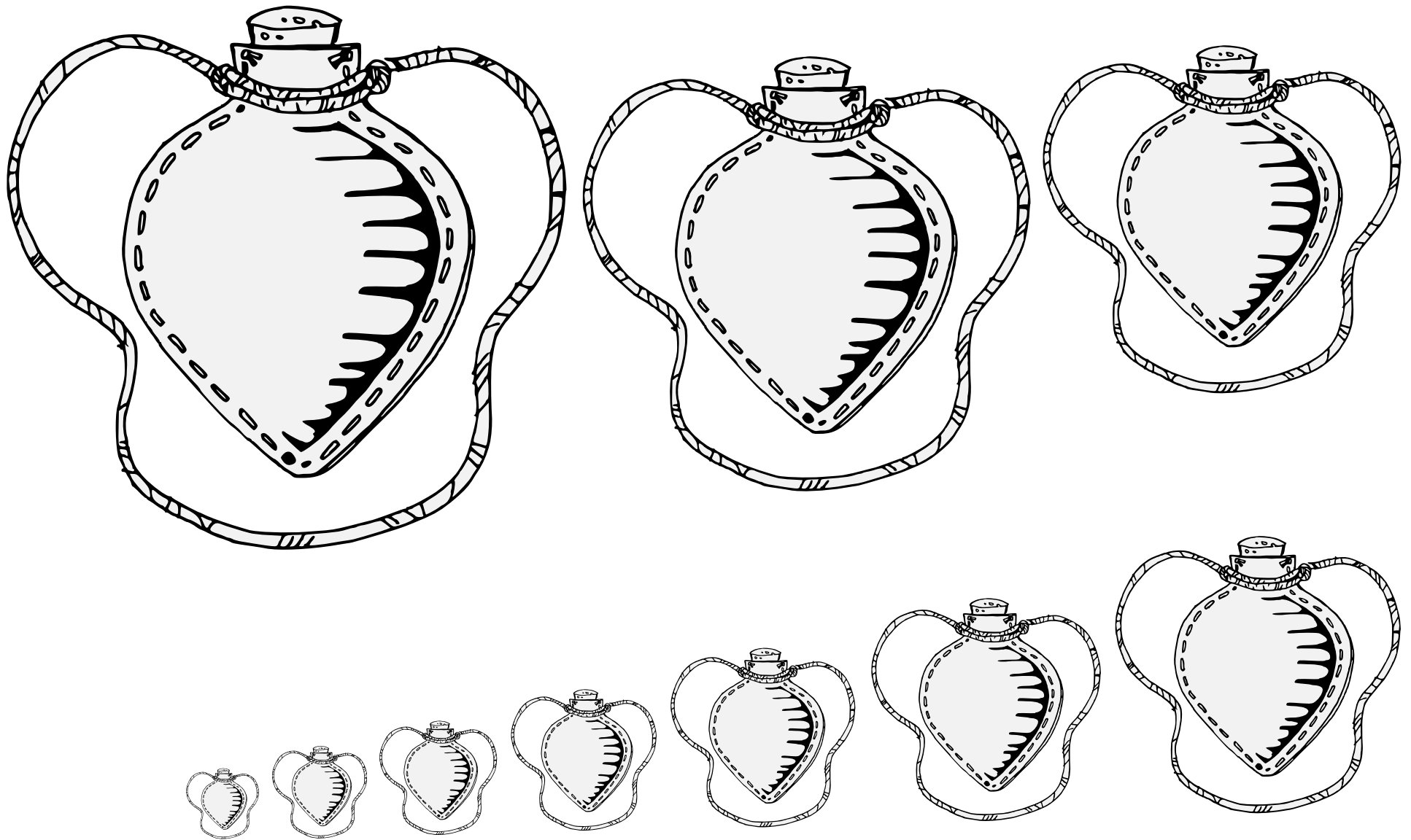

A portable container for water or wine.

Default orientation: upright. No proper coloration.

Source: Pennsic Bored-Artist Collection. Artist: Dorothy Mackey.

Bottle, Leather 14.15

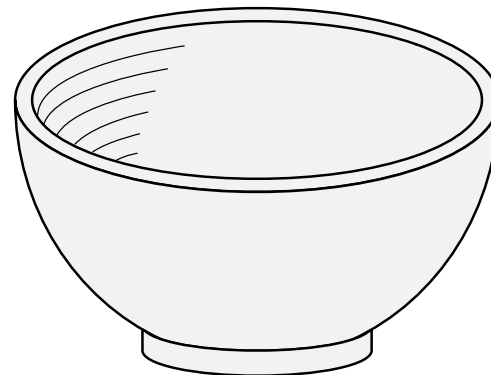
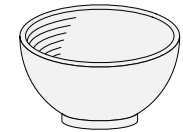
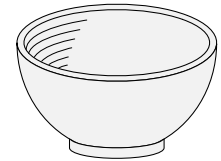
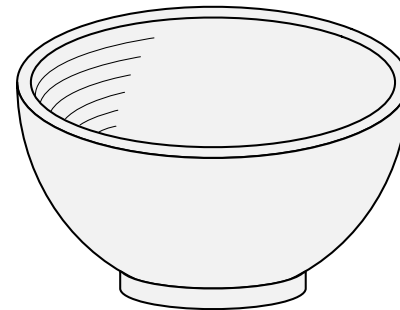
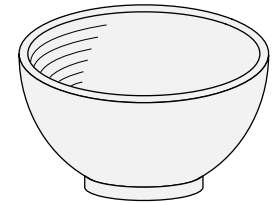
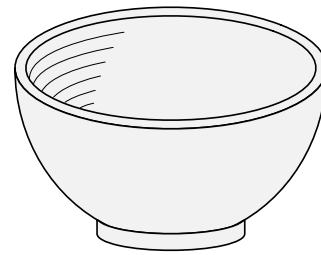
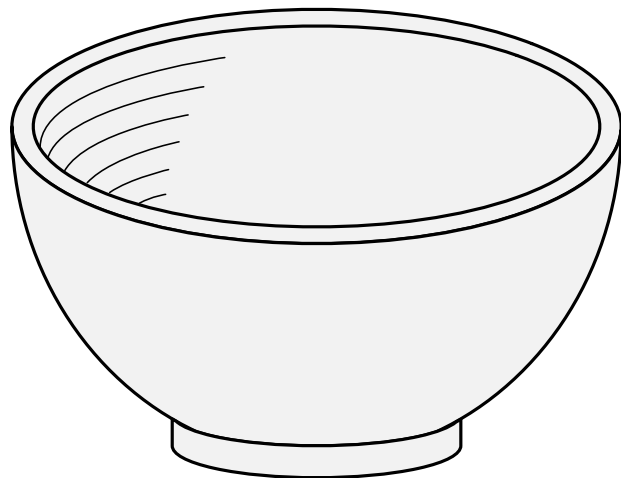
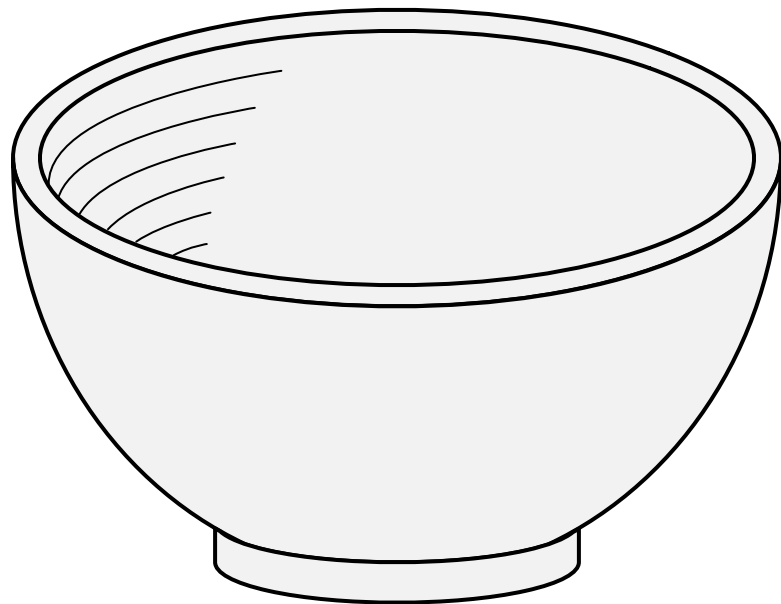

A rounded serving or eating dish.

Default orientation: upright, in profile or three-quarter view. No proper coloration.

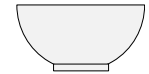
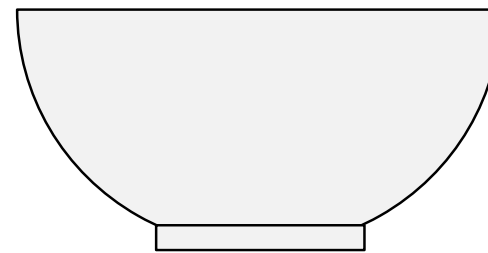
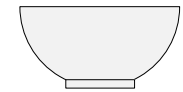
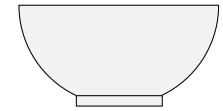
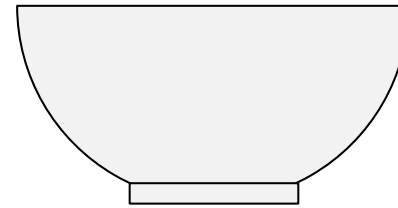
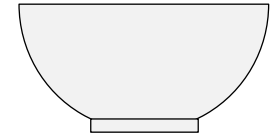
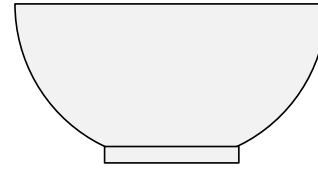
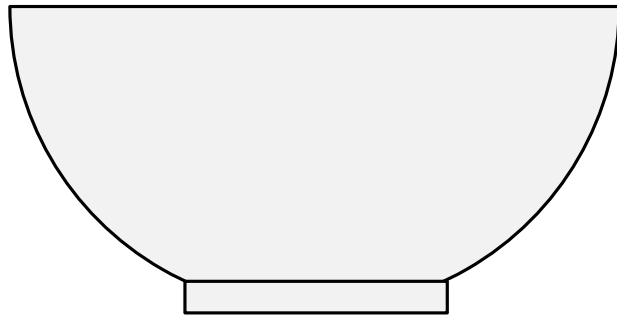
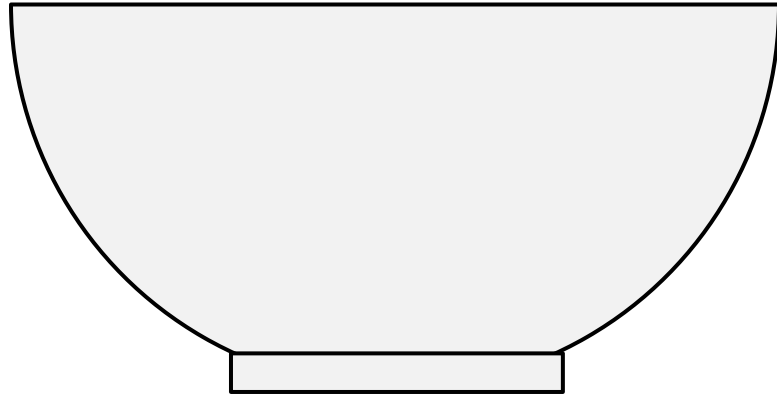

A rounded serving or eating dish.

Default orientation: upright, in profile or three-quarter view. No proper coloration.

Source: SVG Heraldry Components. Artist: Nicholas de Estleche.

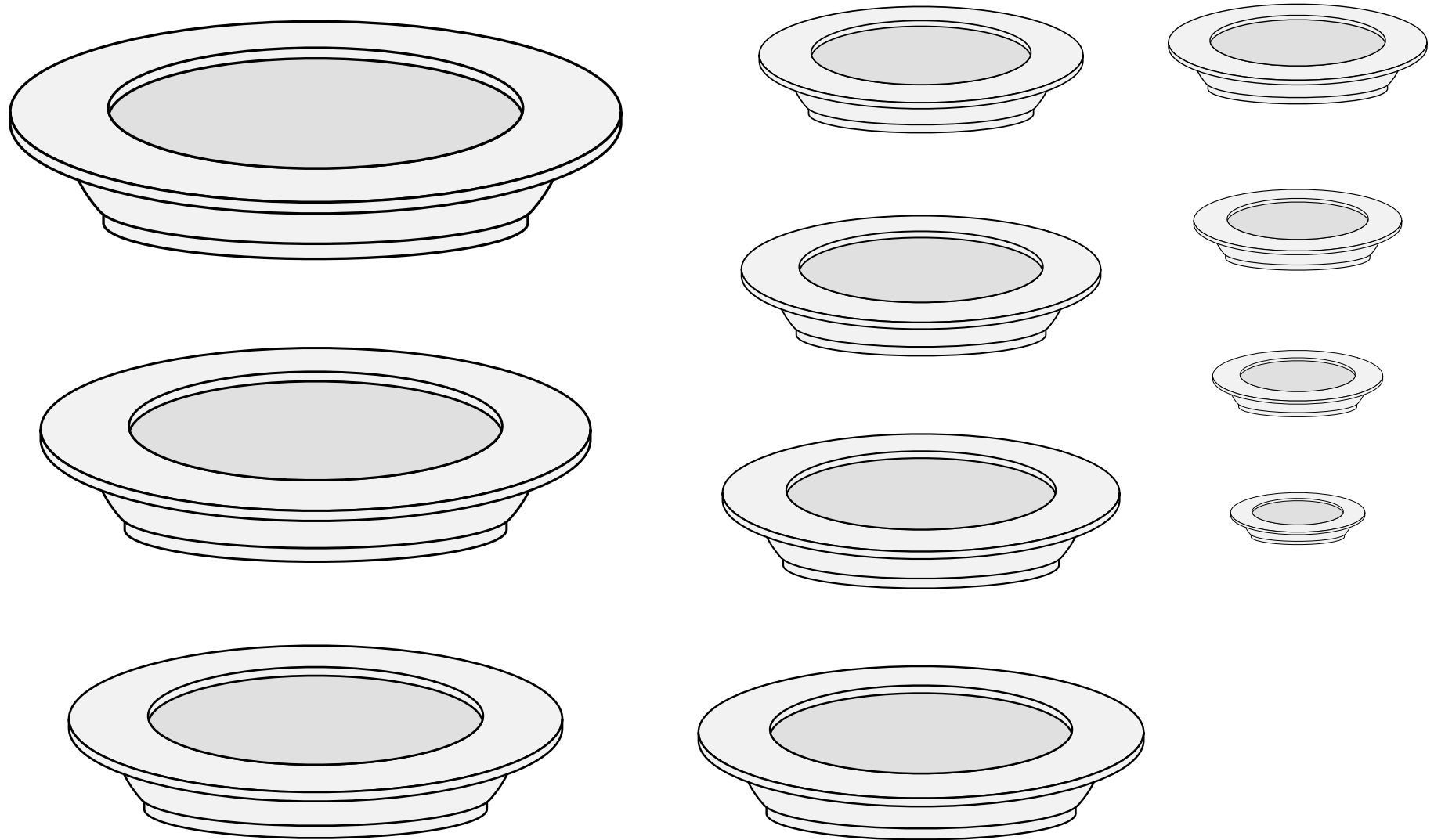

A rounded serving or eating dish.

Default orientation: upright, in profile or three-quarter view. No proper coloration.

Source: Codice Trivulziano 2168. Artist unknown. (Folio 13v.)

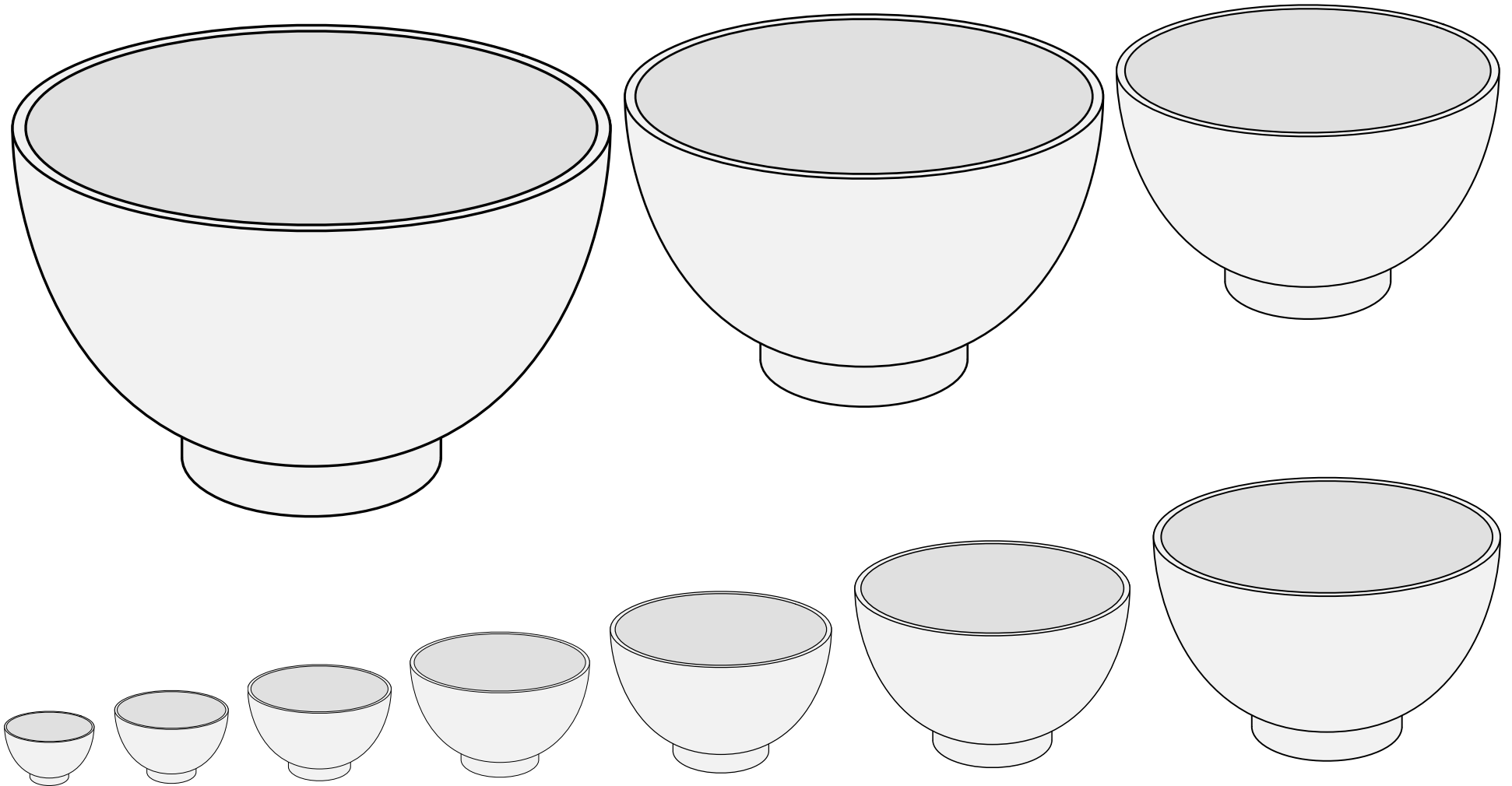

A rounded serving or eating dish.

Default orientation: upright, in profile or three-quarter view. No proper coloration.

Bowl (4) 14.19

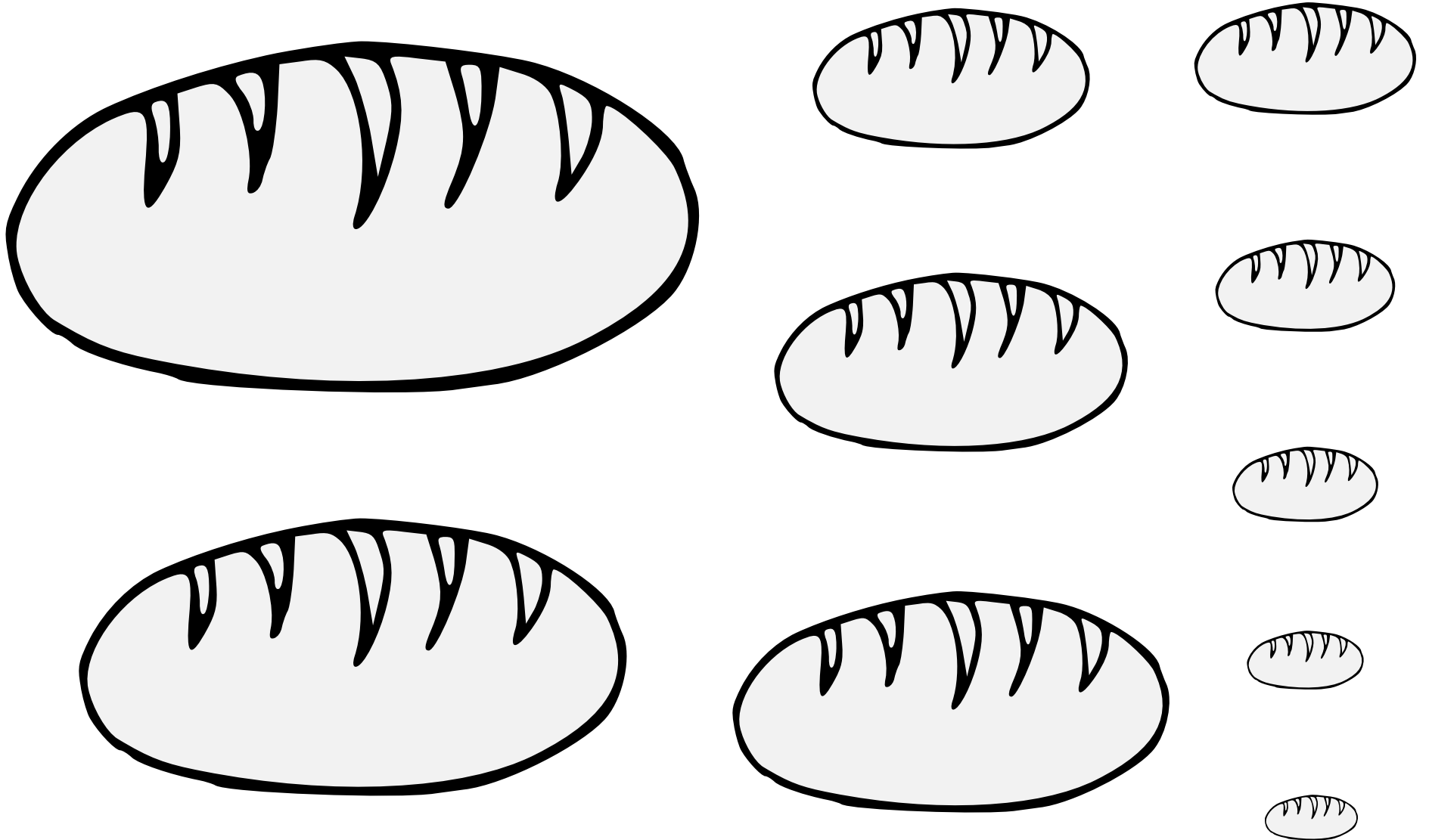

A baked loaf of bread.

Default orientation: fesswise. Proper coloration: brown.

Source: Pennsic Traceable Art. Artist: Roana d'Evreux.

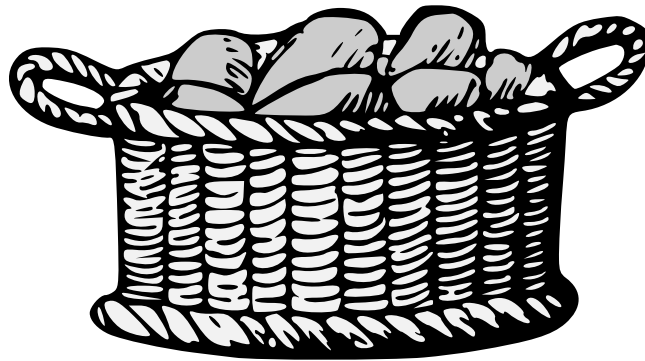
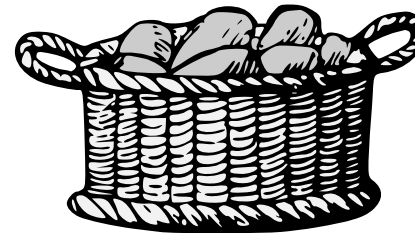
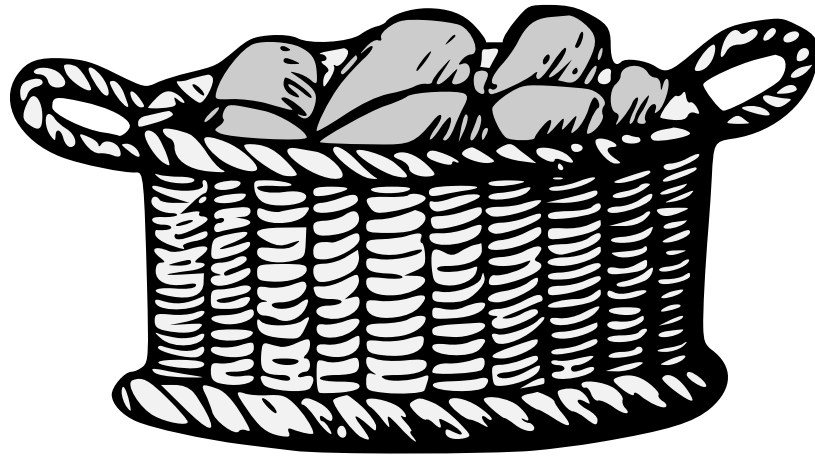

A baked loaf of bread.

Default orientation: fesswise. Proper coloration: brown.

Source: A Glossary of Terms Used in Heraldry. Artist: James or Irene Parker.

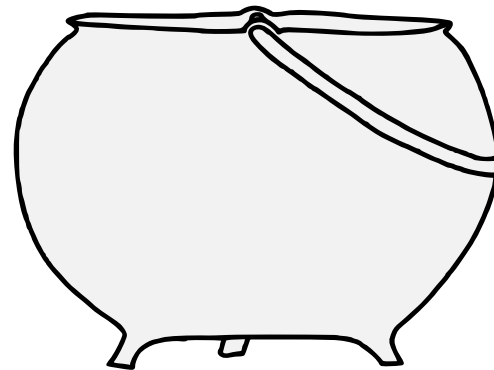
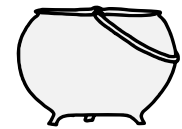
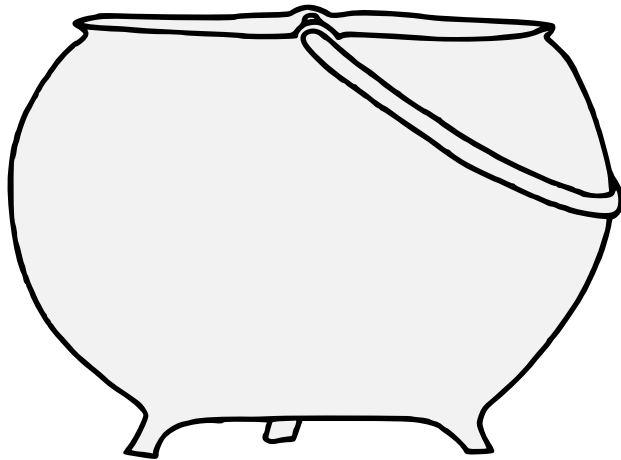
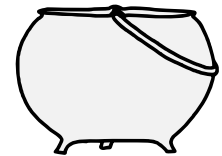
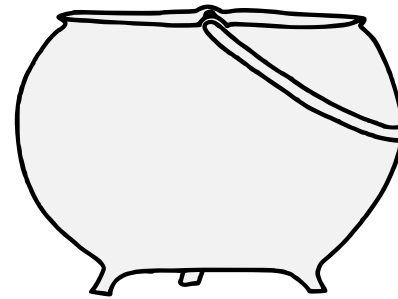
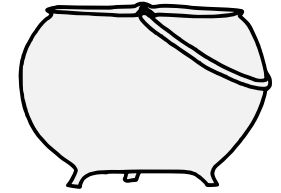
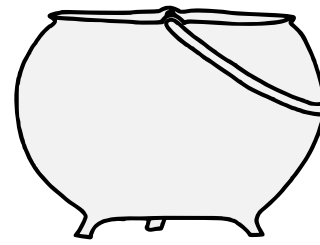
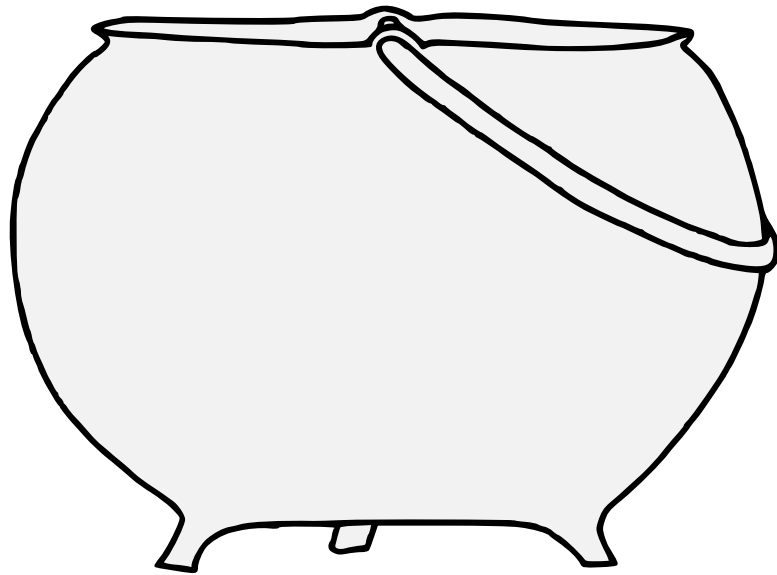

A large round cooking pot.

Source: Pennsic Bored-Artist Collection. Artist: Angharat Goch verch Gwenhover.

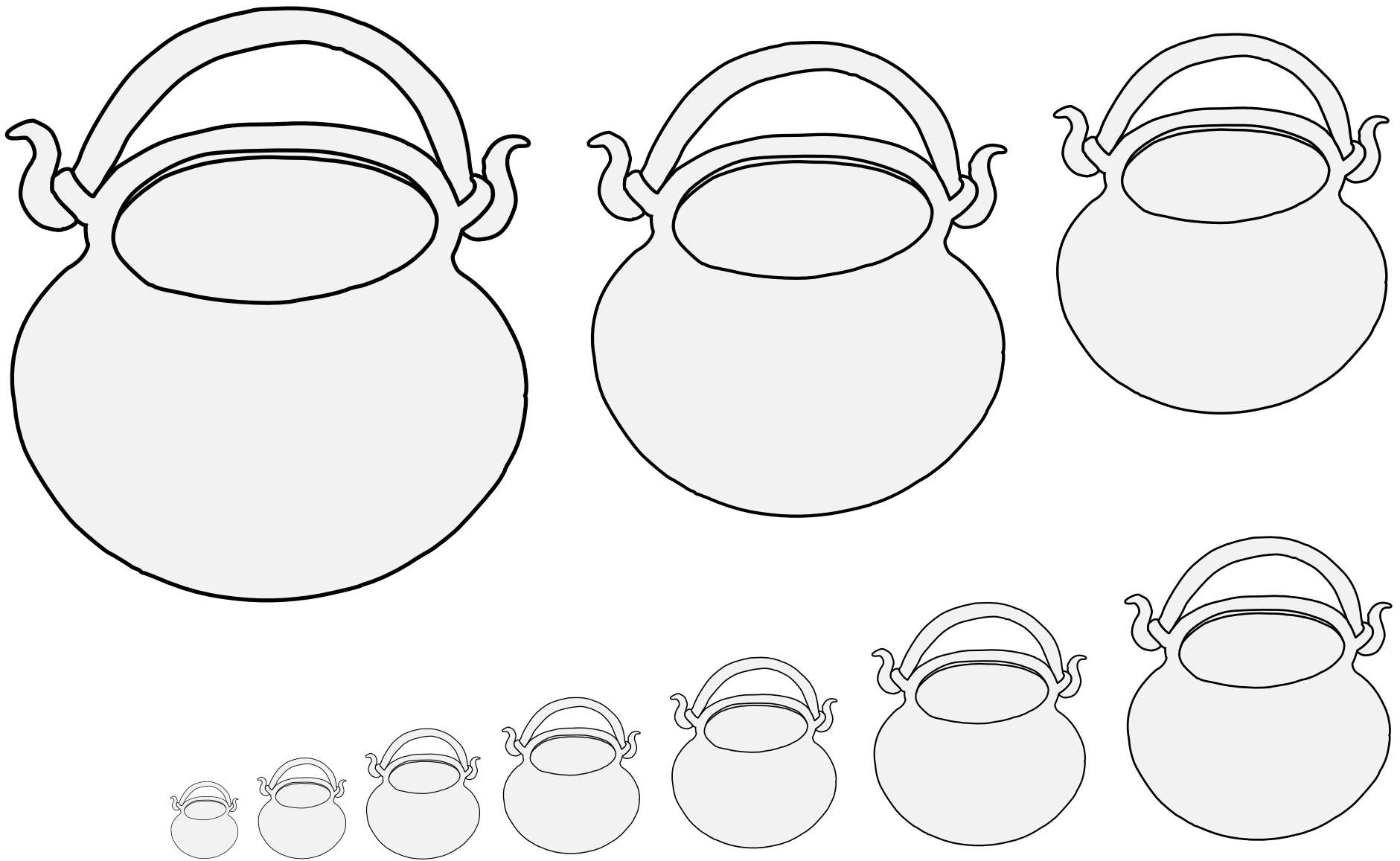

A large round cooking pot.

Default orientation: upright. No proper coloration.

Source: Scheibler Armorial. Artist unknown. (From the arms of Pfersee.)

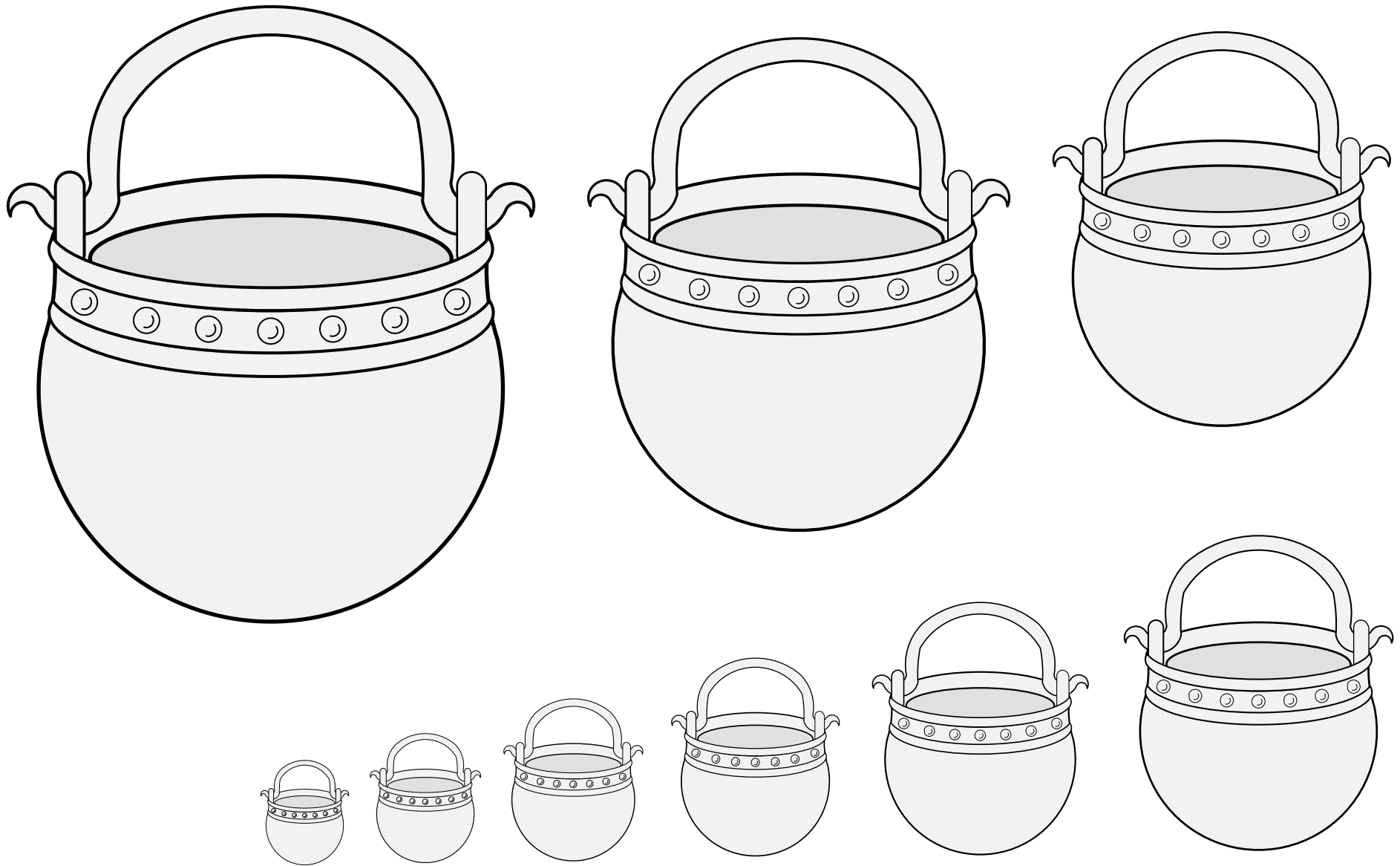

A large round cooking pot.

Default orientation: upright. No proper coloration.

Source: Viking Answer Lady SVG Images For Heraldists. Artist: Gunnvör silfrhárr.

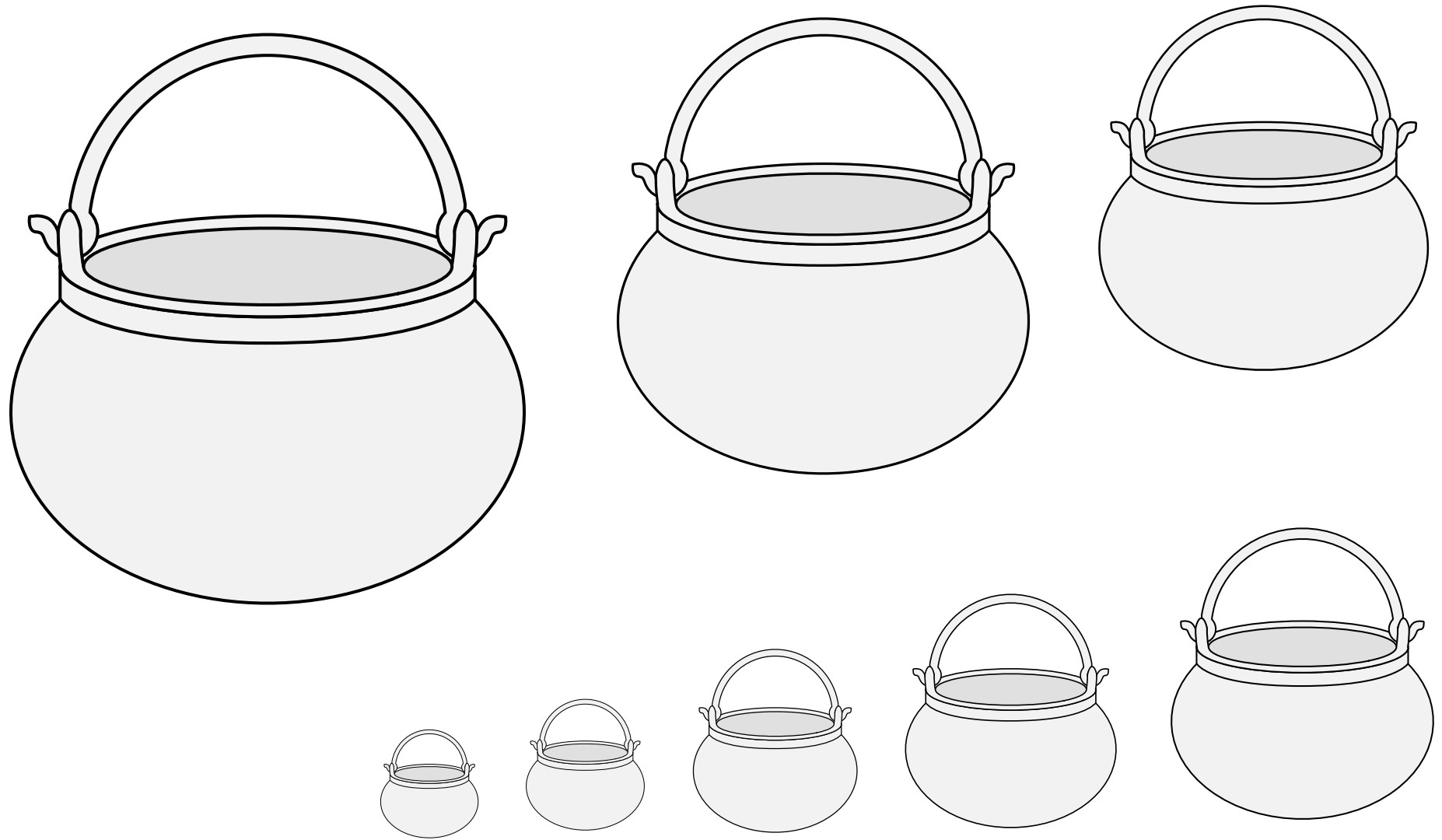

A large round cooking pot with a semi-circular handle.
Default orientation: upright. No proper coloration.

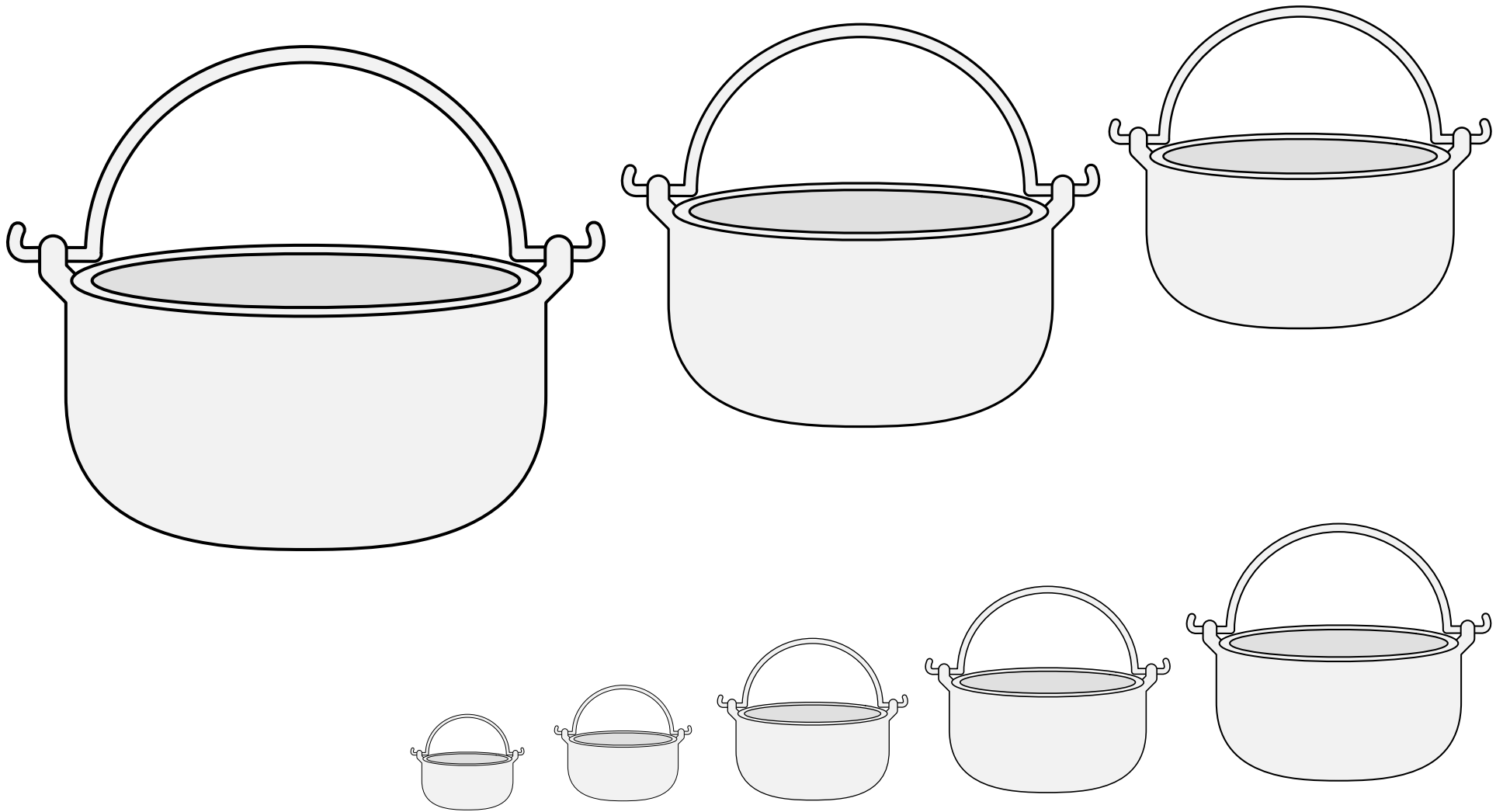

A large round cooking pot with a semi-circular handle.

Default orientation: upright. No proper coloration.

Source: Insignia Lucensium, Senensium, Pisanorum.

Artist unknown. (Arms of Pavioli, folio 154r.)

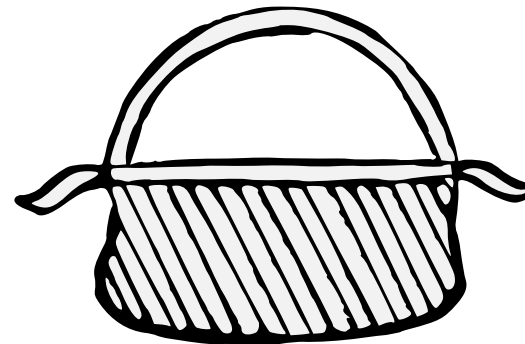
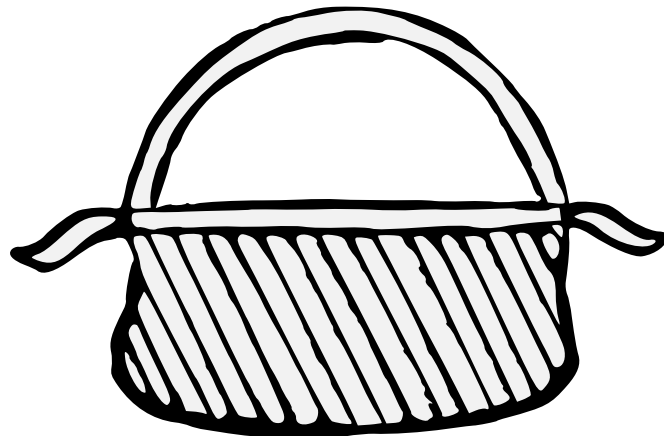
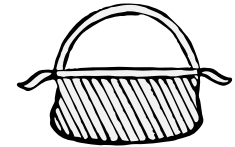
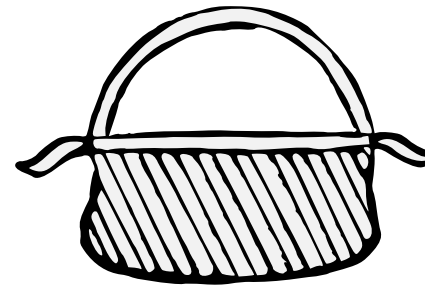
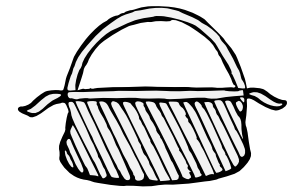
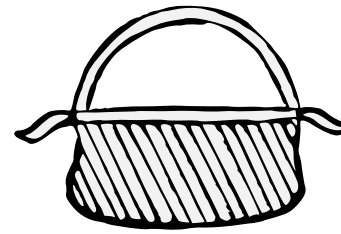
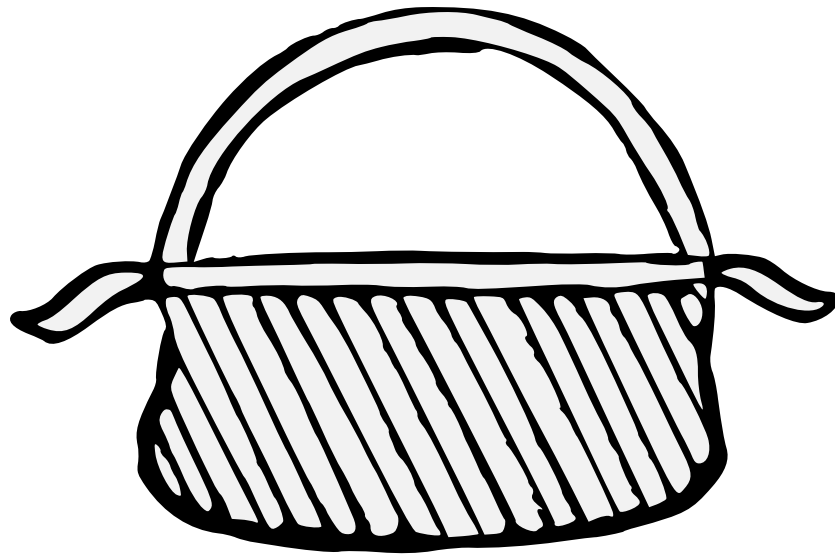

A large round cooking pot with a semi-circular handle.

Default orientation: upright. No proper coloration.

Source: Nobleza del Andaluzia. Artist unknown.
(Arms of Gaona, folio 70.)

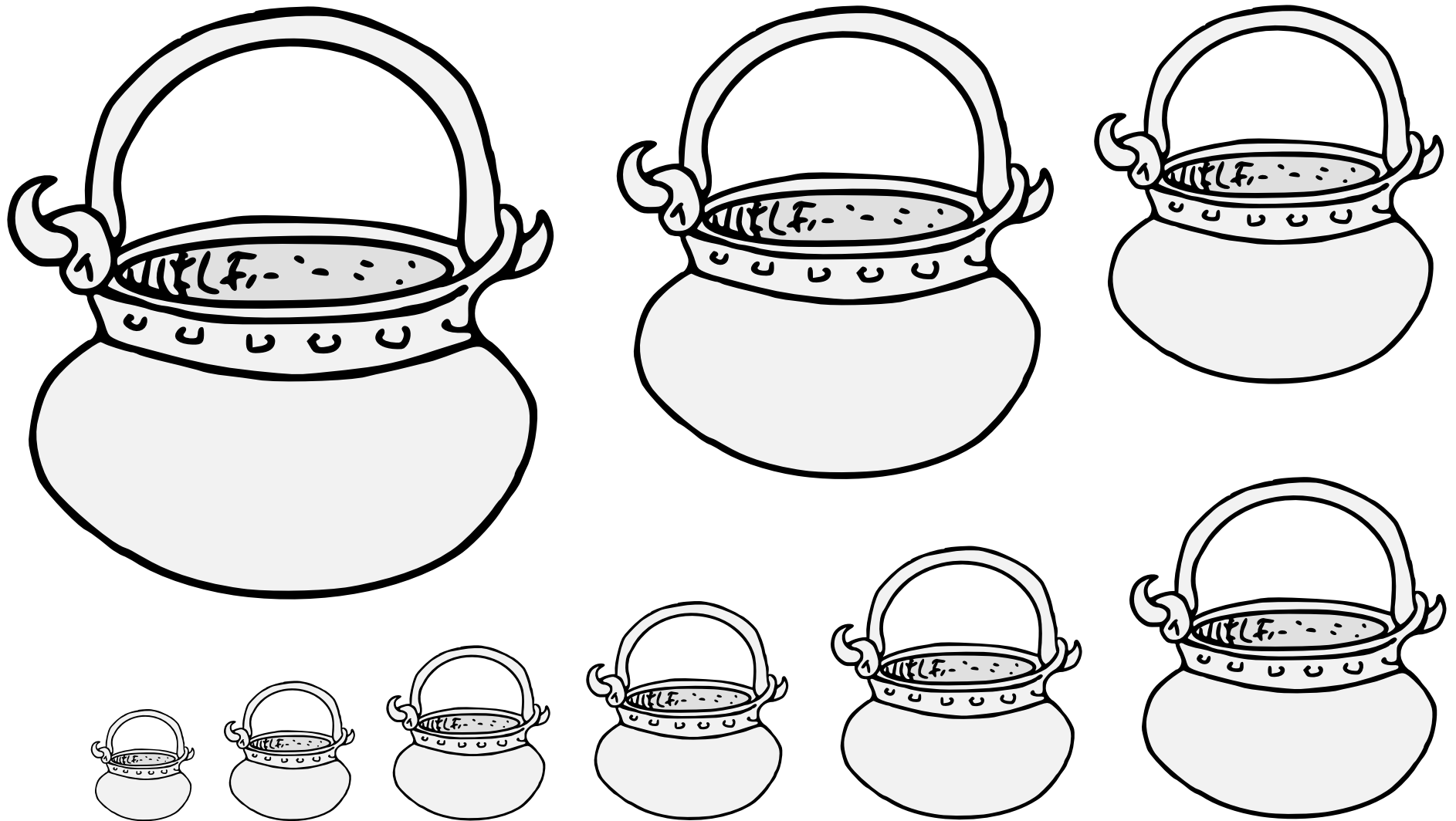

A large round cooking pot with a semi-circular handle.

Default orientation: upright. No proper coloration.

Source: Wappenbuch der Arlberg-Bruderschaft. Artist: Vigil Raber.
Adapted by Jessimond of Emerickeskepe.

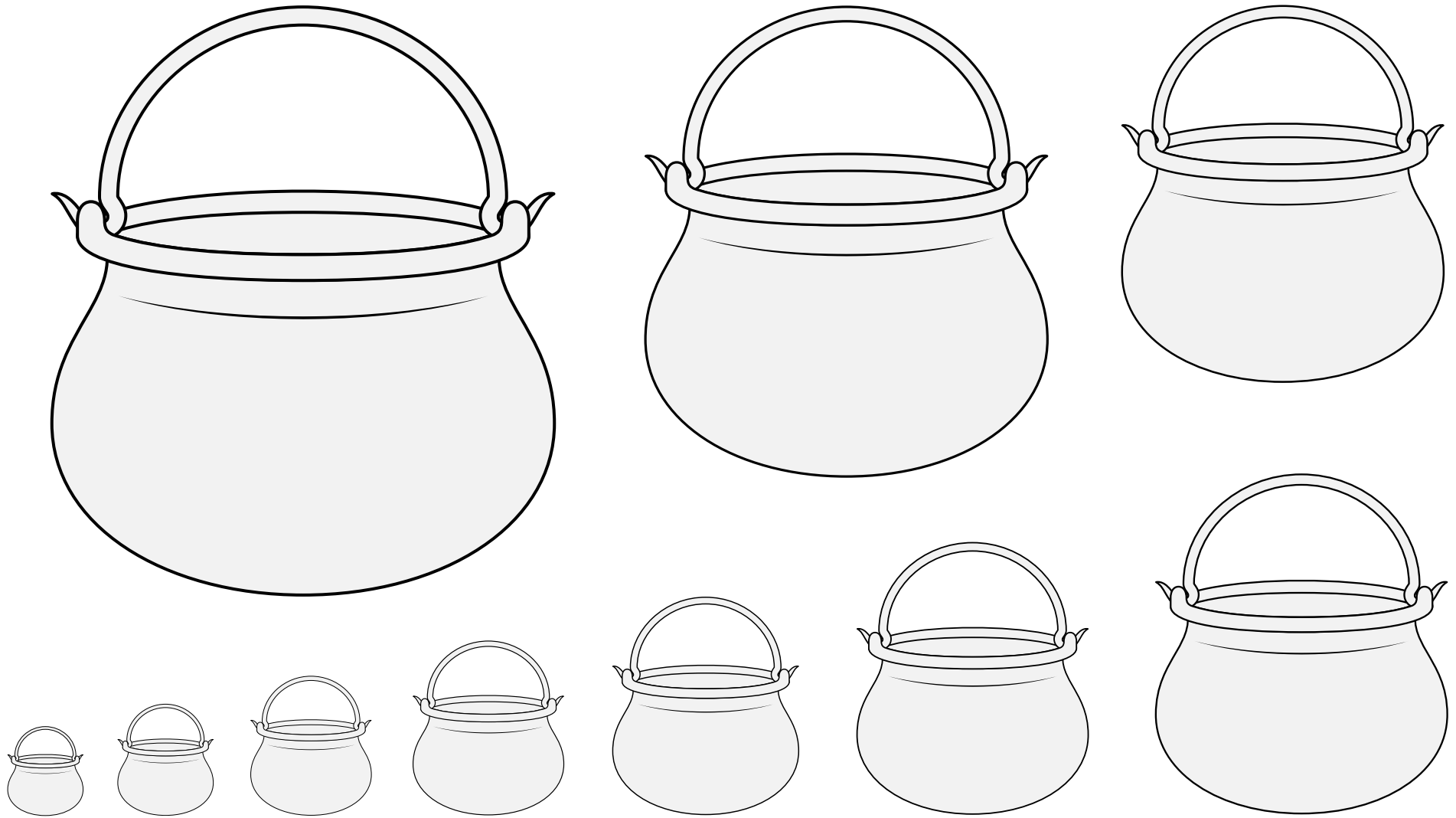

A large round cooking pot with a semi-circular handle.
Default orientation: upright. No proper coloration.
Source: WappenWiki. Artist: Joakim Spuller.

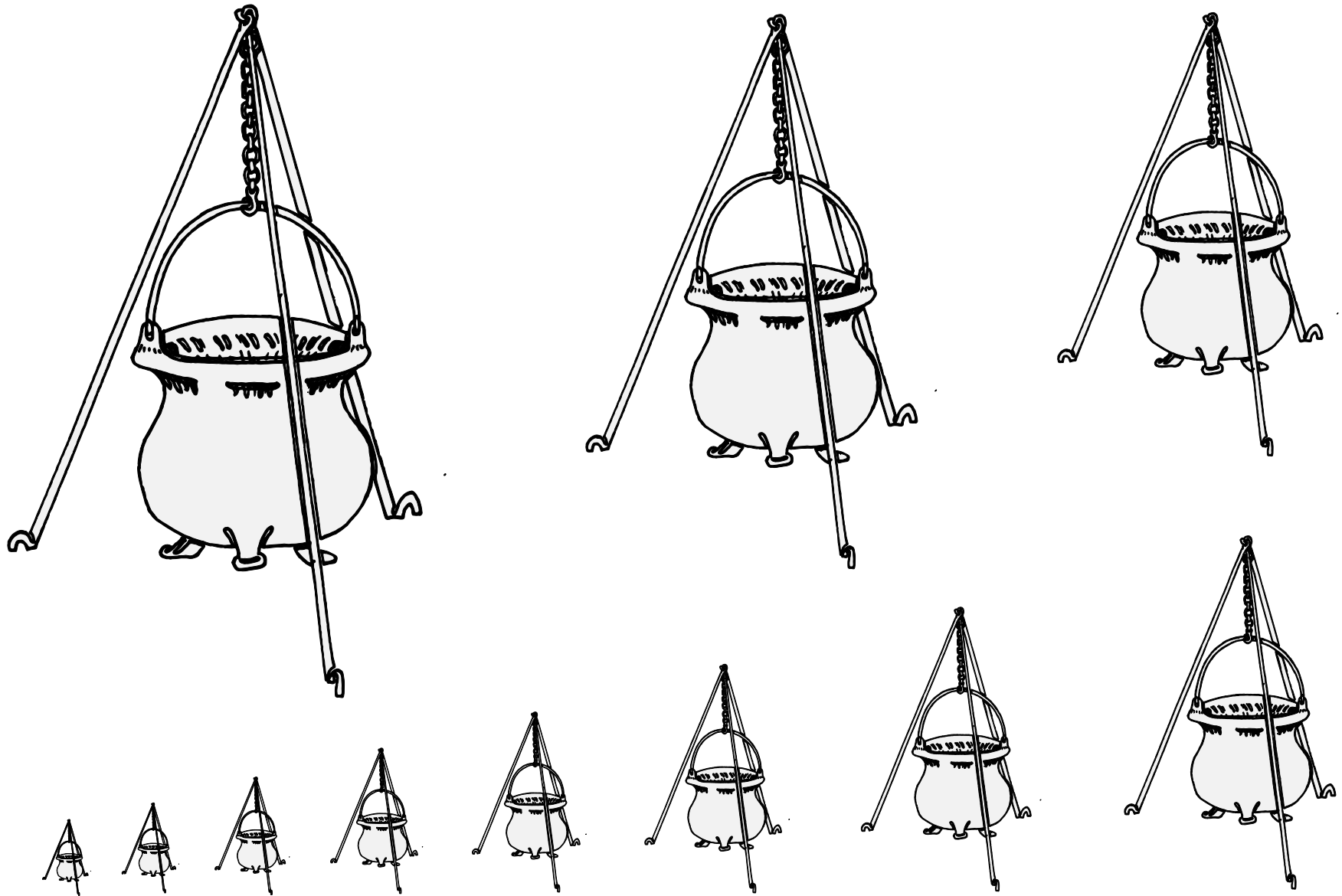

A large round cooking pot with a stand to suspend it over a fire.

Source: Heraldic Templates. Artist: Torric inn Björn.

Cauldron Hanging From a Tripod 14.30



A footed cup.

Default orientation: palewise. No proper coloration.

Source: Pennsic Traceable Art. Artist unknown. Adapted by Mathghamhain Ua Ruadháin.



A footed cup.

Default orientation: palewise. No proper coloration.

Source: Heraldic Templates. Artist: Torric inn Björn.

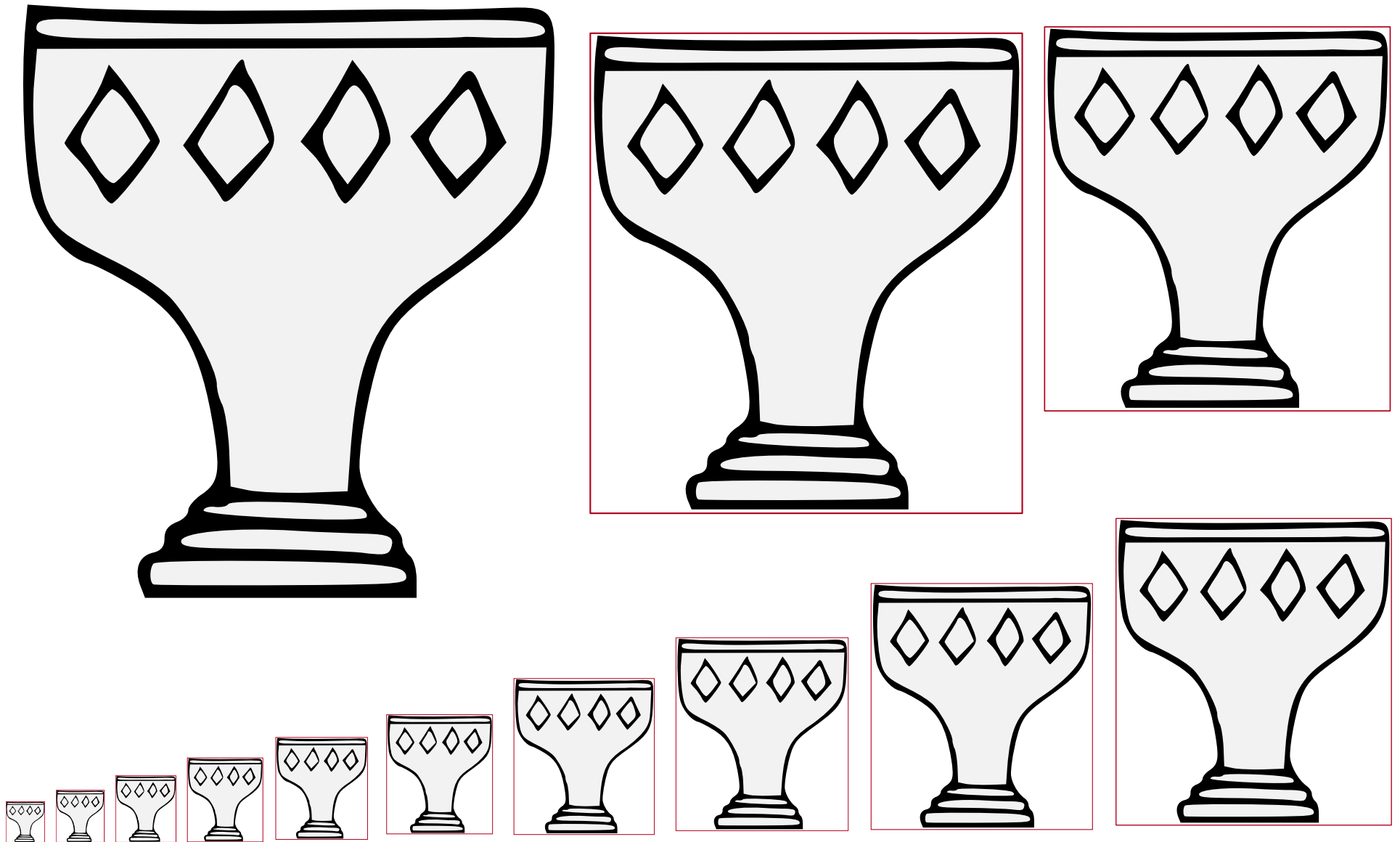

A footed cup.

Default orientation: palewise. No proper coloration.

Source: Pennsic Traceable Art. Artist unknown.



A footed cup.

Default orientation: palewise. No proper coloration.

Source: Viking Answer Lady SVG Images For Heraldry. Artist: Gunnvôr silfrárr.

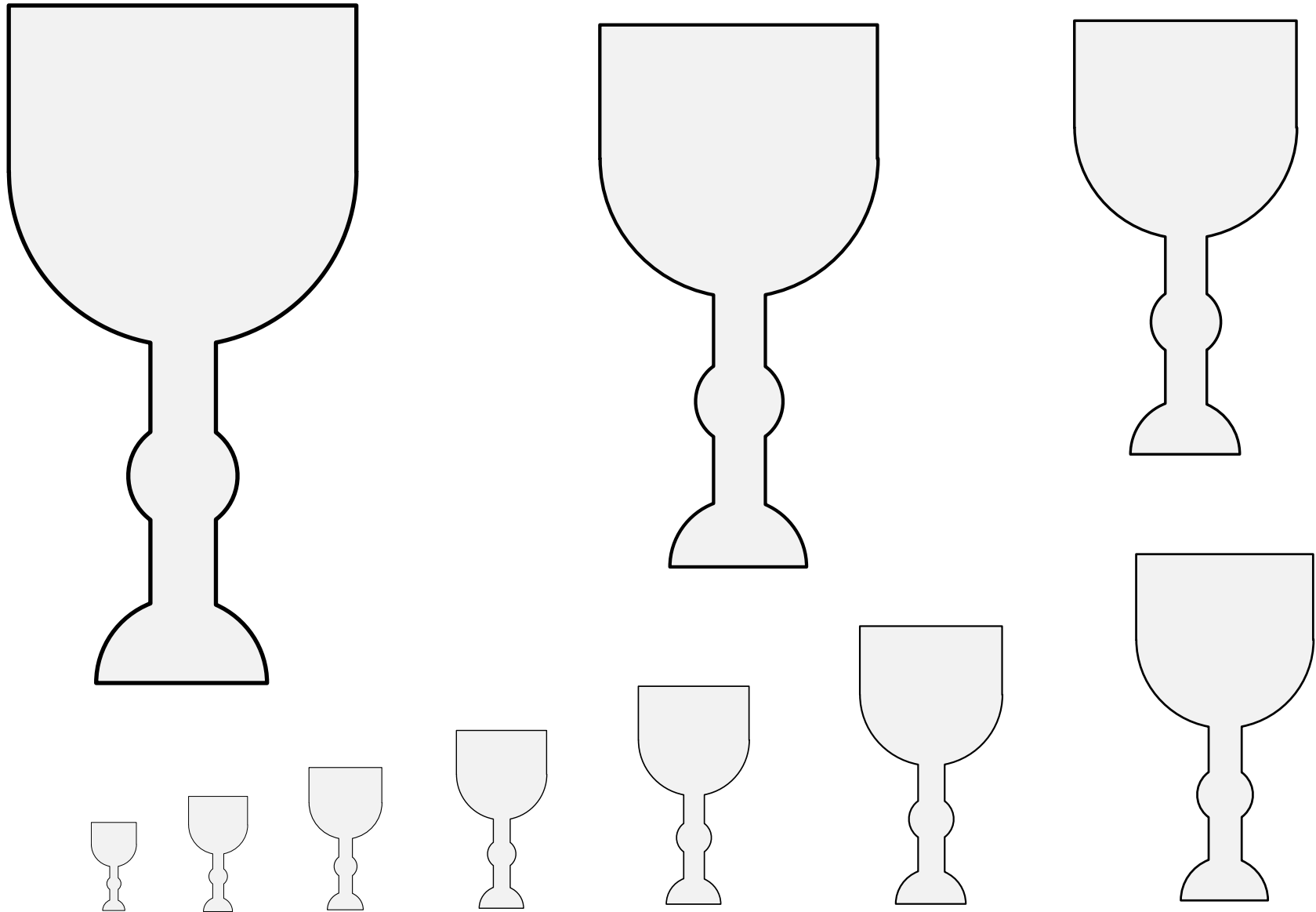

A footed cup.

Default orientation: palewise. No proper coloration.

Artist: Þórý Veðardóttir. License: CC BY-NC-SA; commercial use requires permission.



A footed cup.

Default orientation: palewise. No proper coloration.



A footed cup.

Default orientation: palewise. No proper coloration.

Source: WappenWiki. Artist: Joakim Spuller.

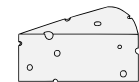
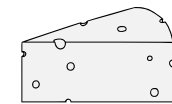
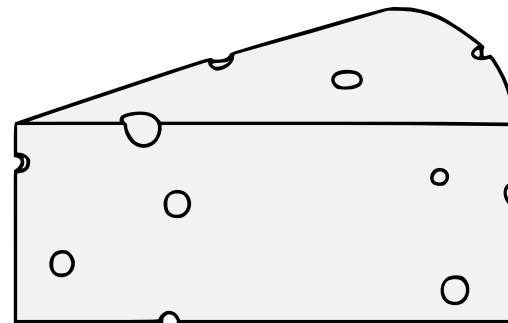
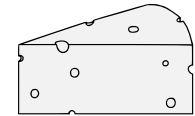
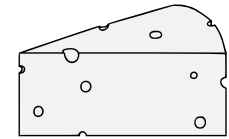
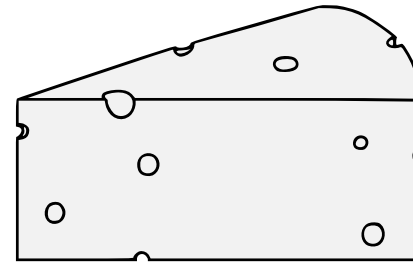
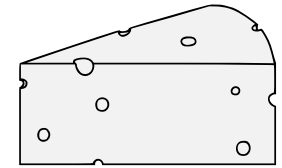
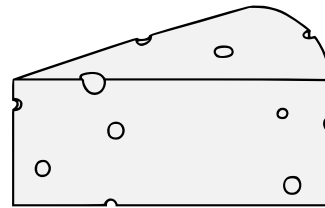
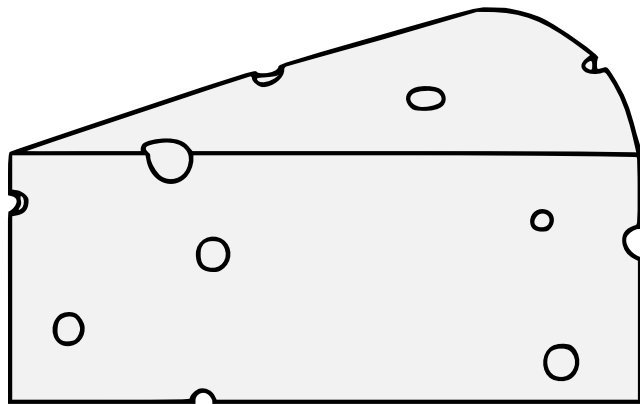
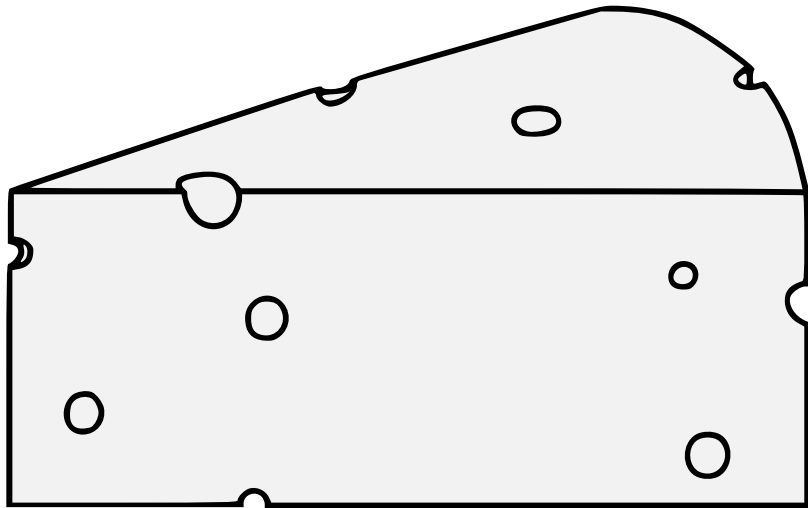

A long-lived dairy product.

Default orientation: if a wedge, point to dexter. No proper coloration.

Artist: Jon Cheseey.

Cheese, Wedge of 14.38

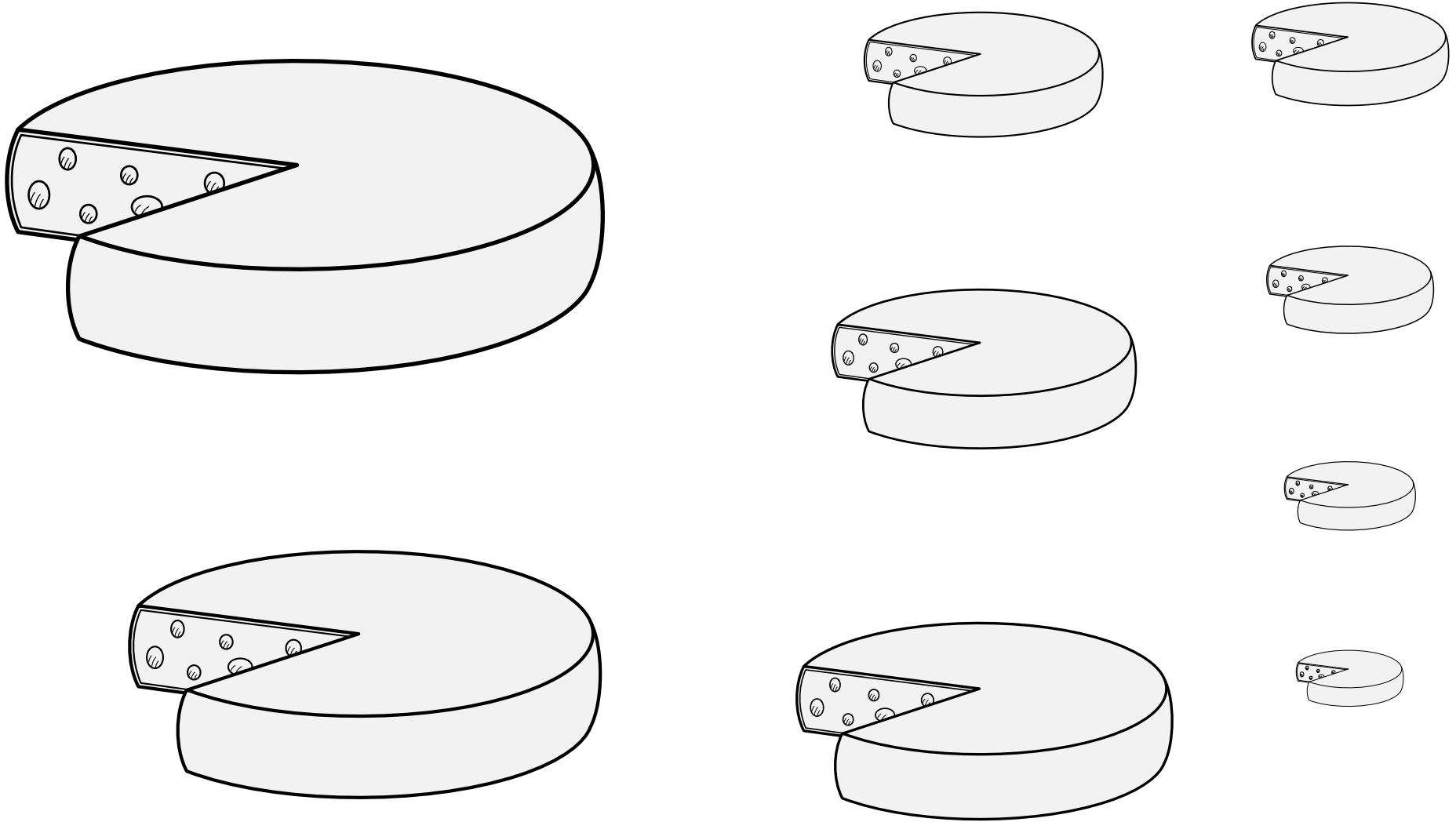

A long-lived dairy product.
Default orientation: fesswise. No proper coloration.

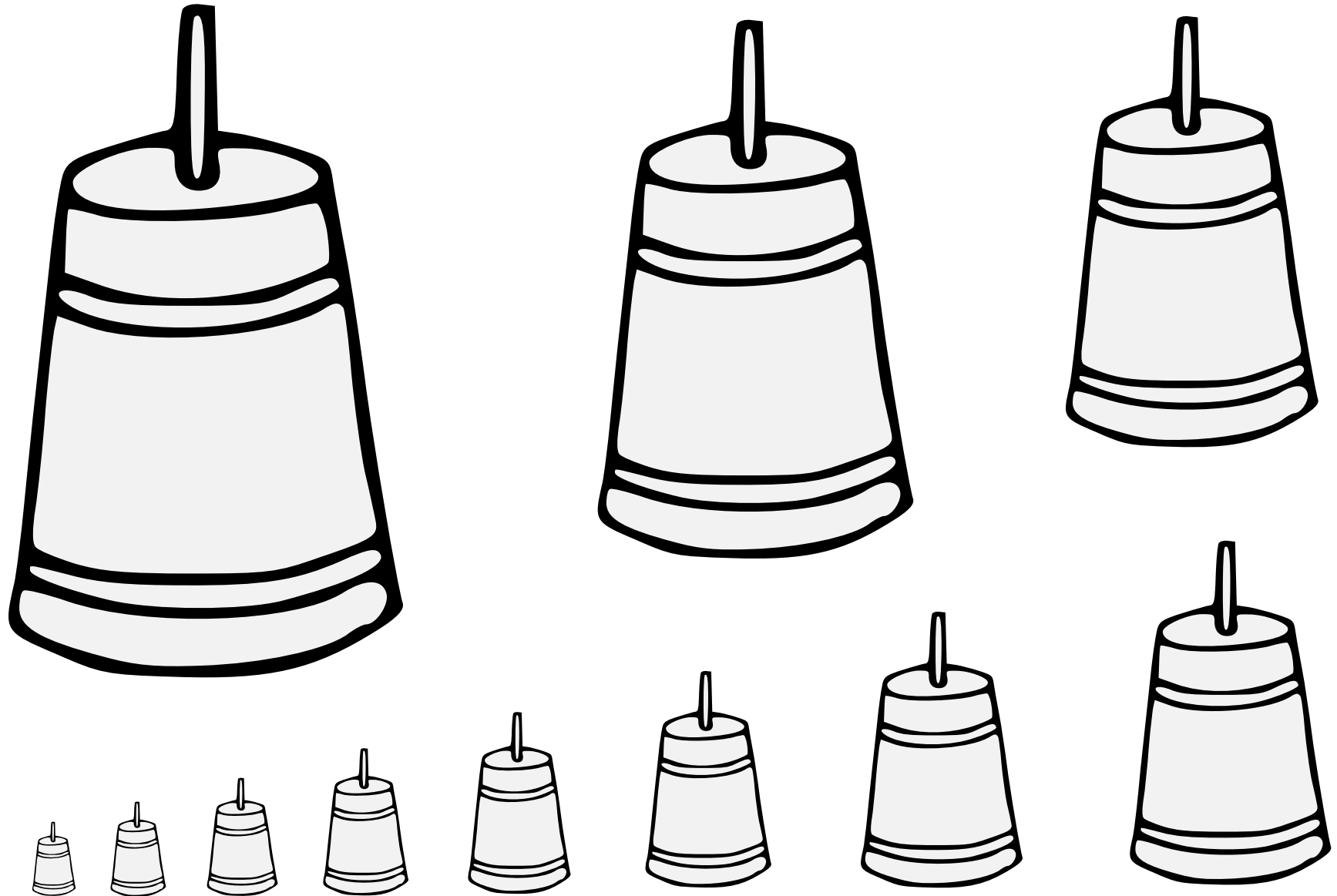

A container used for agitating cream.

Default orientation: plunger to chief. Proper coloration: brown wood.

Source: Pennsic Traceable Art. Artist unknown.

Churn, Butter (1) 14.40

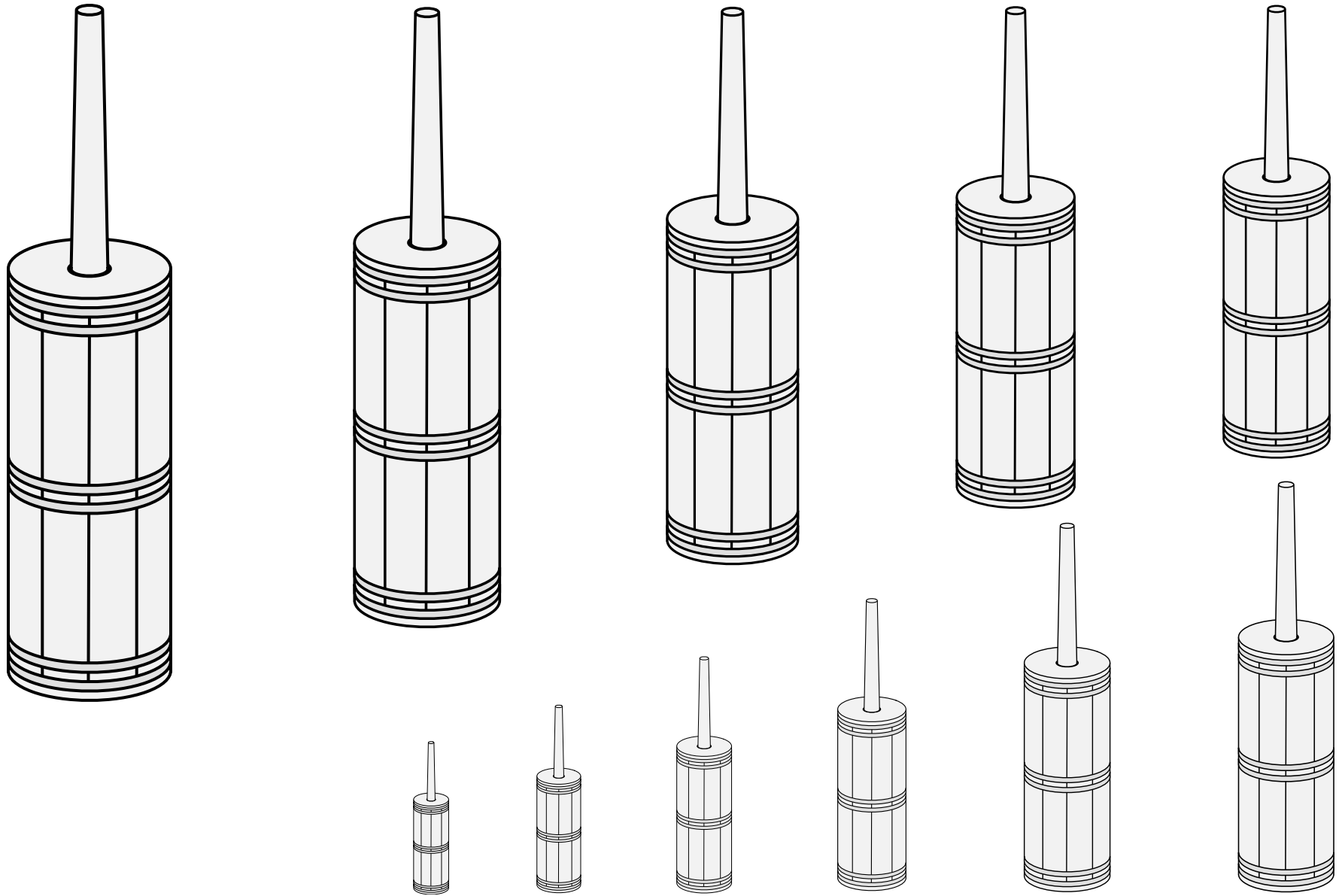

A container used for agitating cream.

Default orientation: plunger to chief. Proper coloration: brown wood.

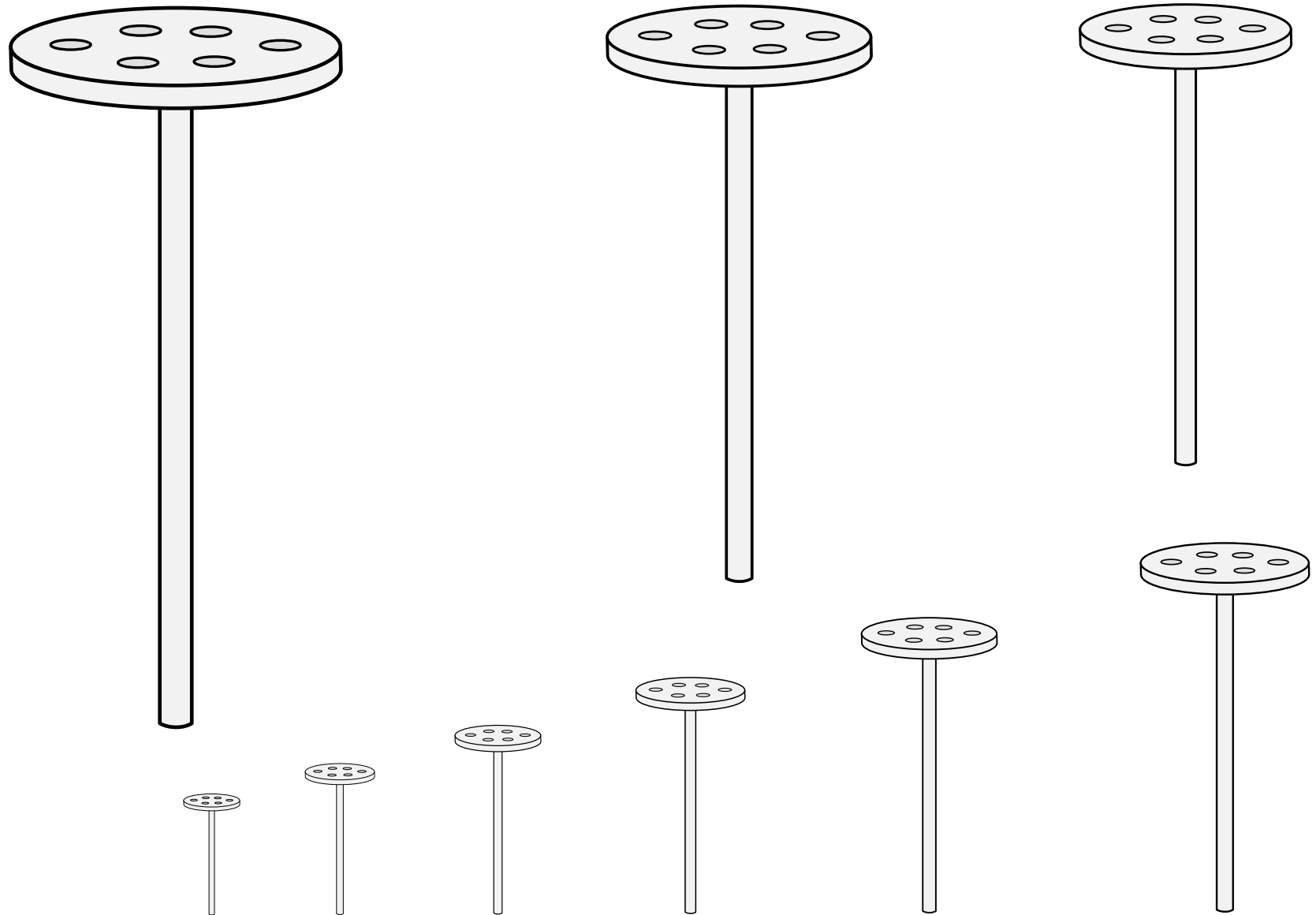

A perforated disk with a long handle used to churn dairy products.

Default orientation: found in period with handle to base. Proper coloration: brown wood.

Source: Austrian State Archives. (Crest of von Sonnberg, 1591.)
Artist unknown. Adapted by Iago ab Adam.

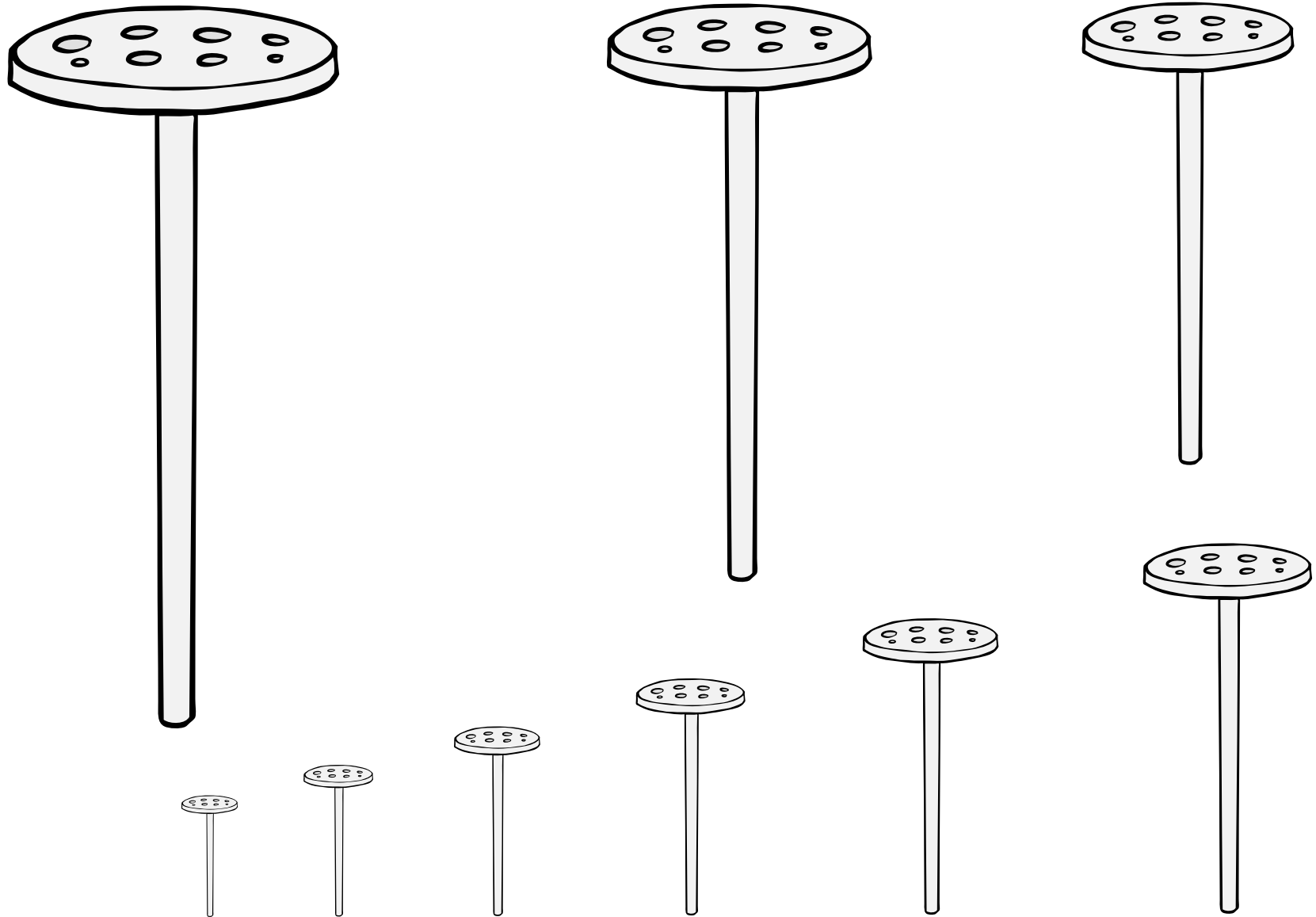

A perforated disk with a long handle used to churn dairy products.

Default orientation: found in period with handle to base. Proper coloration: brown wood.

Source: Austrian State Archives. (Crest of von Sonnberg, 1591.)
Artist unknown. Adapted by Saewynn aet Cnolle.

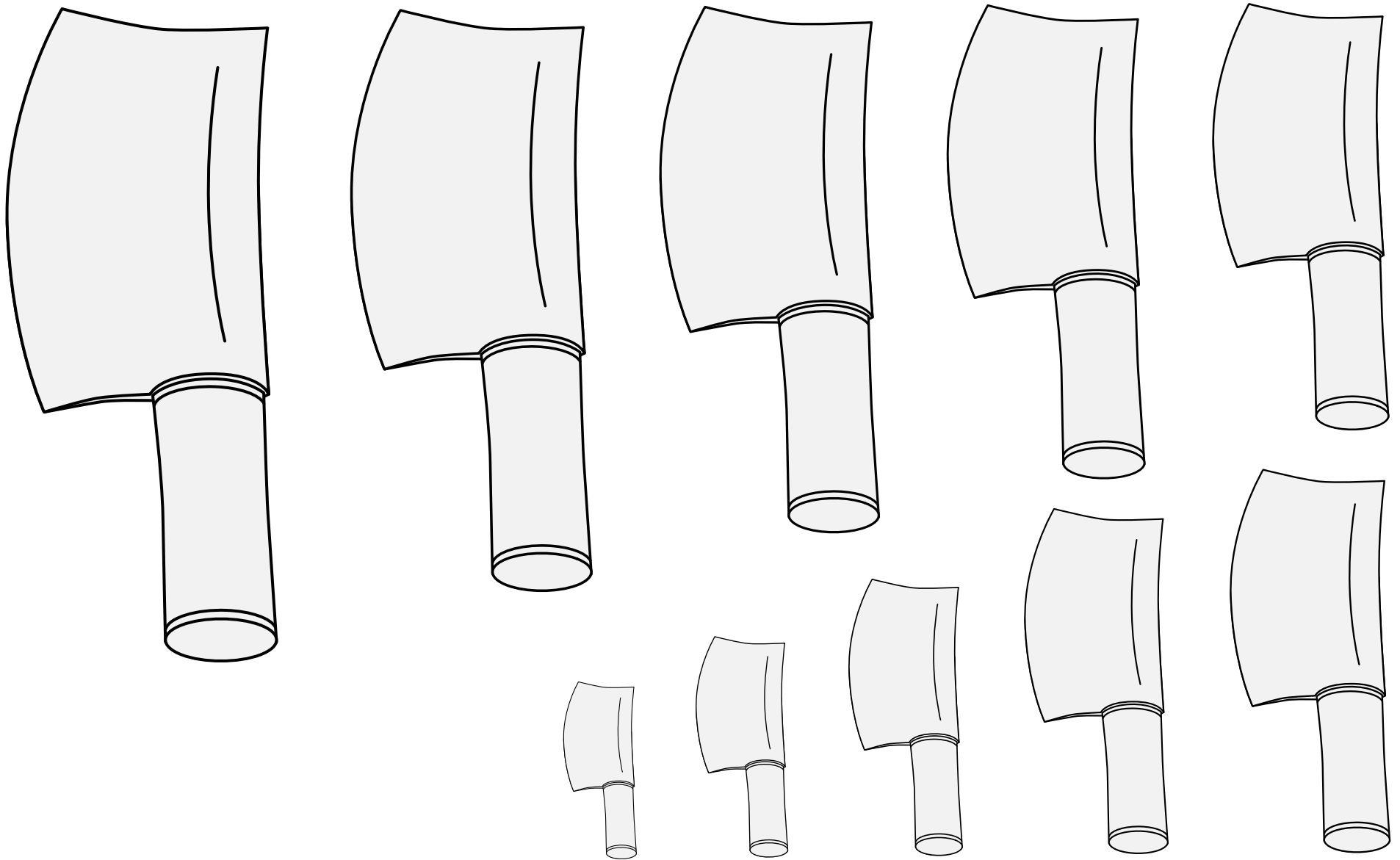

A sharp tool such as one might use in the kitchen.

Default orientation: handle to base, cutting to dexter.

Proper coloration: blade argent, handle Or or brown wood.

Source: Wappenbuch Süddeutschland. Artist unknown.

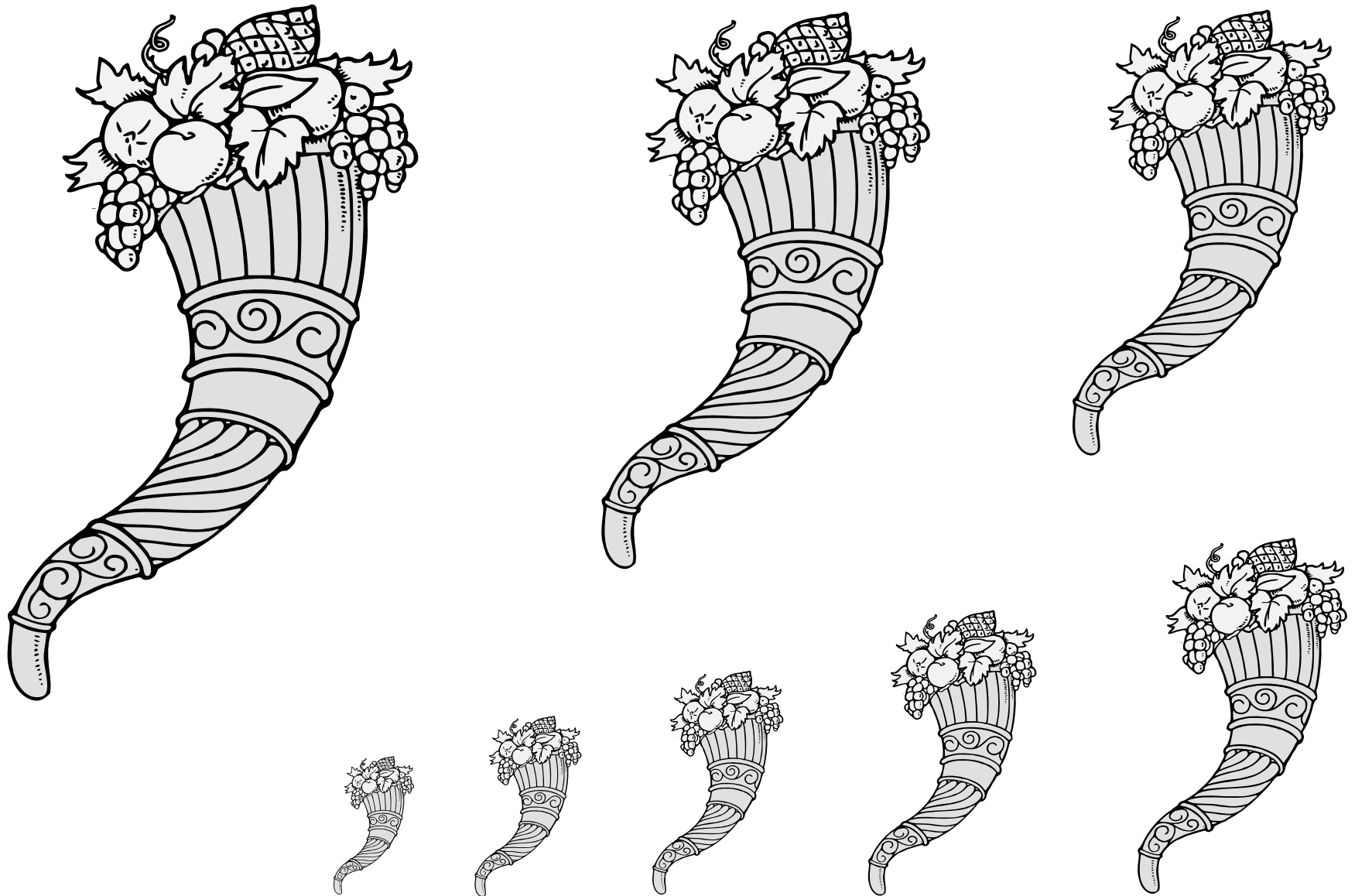

A horn of plenty, filled with fruits.

Default orientation: palewise opening to chief. Proper coloration: brown, with fruits in their natural colors. The tinctures of the horn and fruits may be blazoned separately, as a “cornucopia *tincture* fructed *tincture*” and either may be proper.

Source: The Principles of Design. Artist: George Woolliscroft–Rhead.

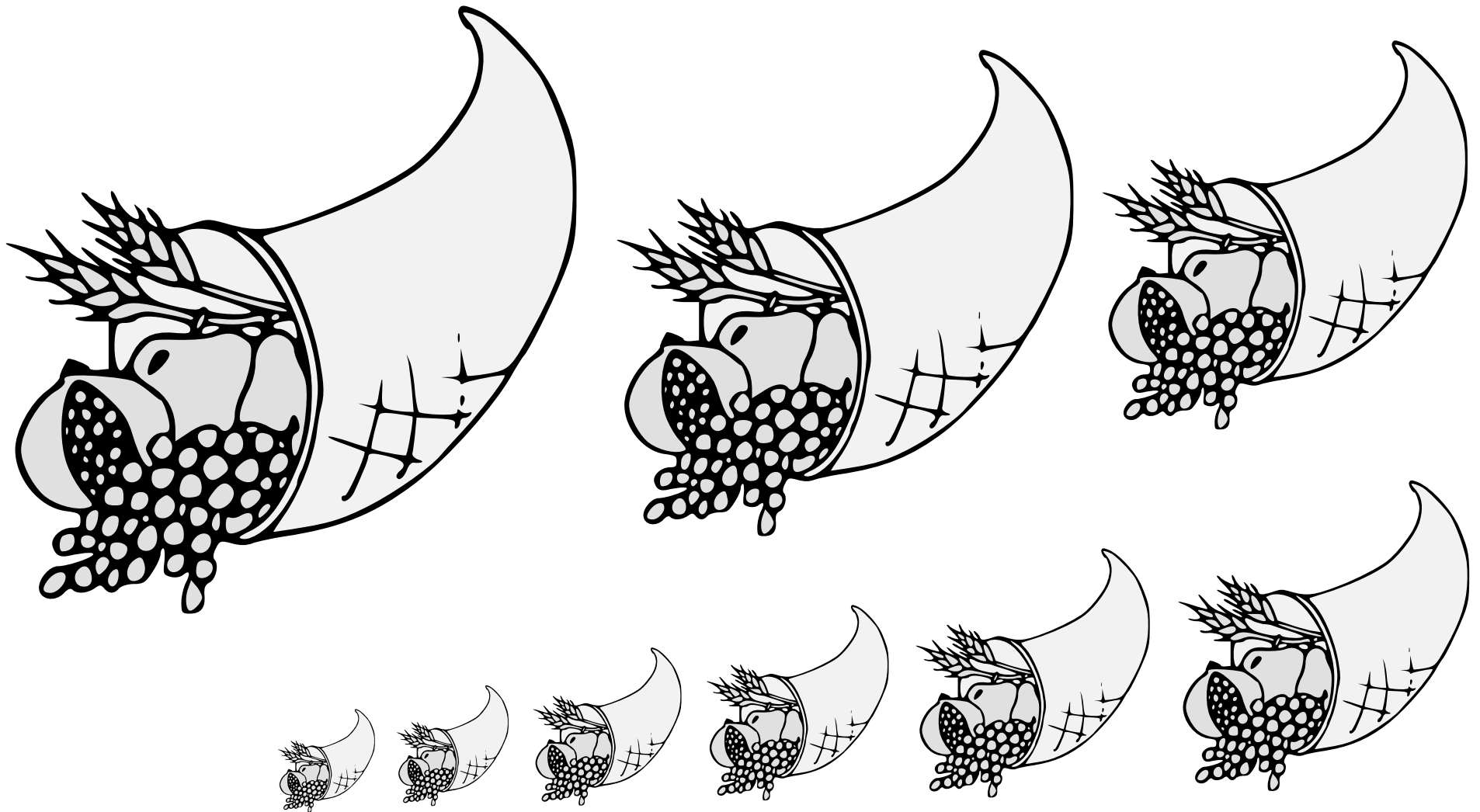

A horn of plenty, filled with fruits.

Default orientation: palewise opening to chief. Proper coloration: brown, with fruits in their natural colors. The tinctures of the horn and fruits may be blazoned separately, as a “cornucopia *tincture* effluent *tincture*” and either may be proper.

The term “effluent” here signifies that the horn is fesswise, opening to dexter, with fruits are tumbling from its mouth.

Source: Pennsic Traceable Art. Artist: Roana d’Evreux.

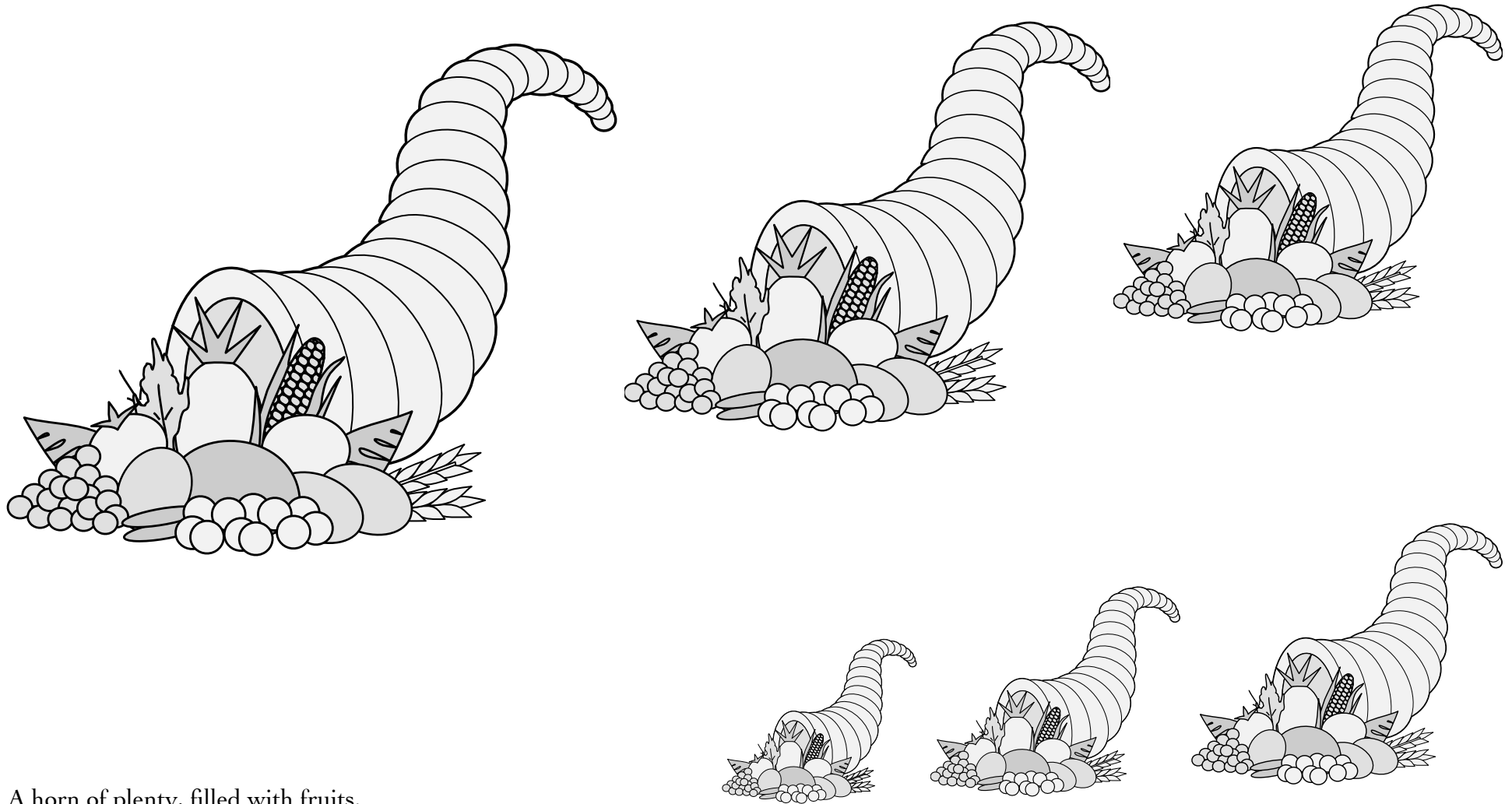

A horn of plenty, filled with fruits.

Default orientation: palewise opening to chief. Proper coloration: brown, with fruits in their natural colors.

The tinctures of the horn and fruits may be blazoned separately, as a “cornucopia tincture effluent tincture” and either may be proper.

The term “effluent” here signifies that the horn is fesswise, opening to dexter, with fruits are tumbling from its mouth.

Source: OpenClipArt. Artist: Firkin.

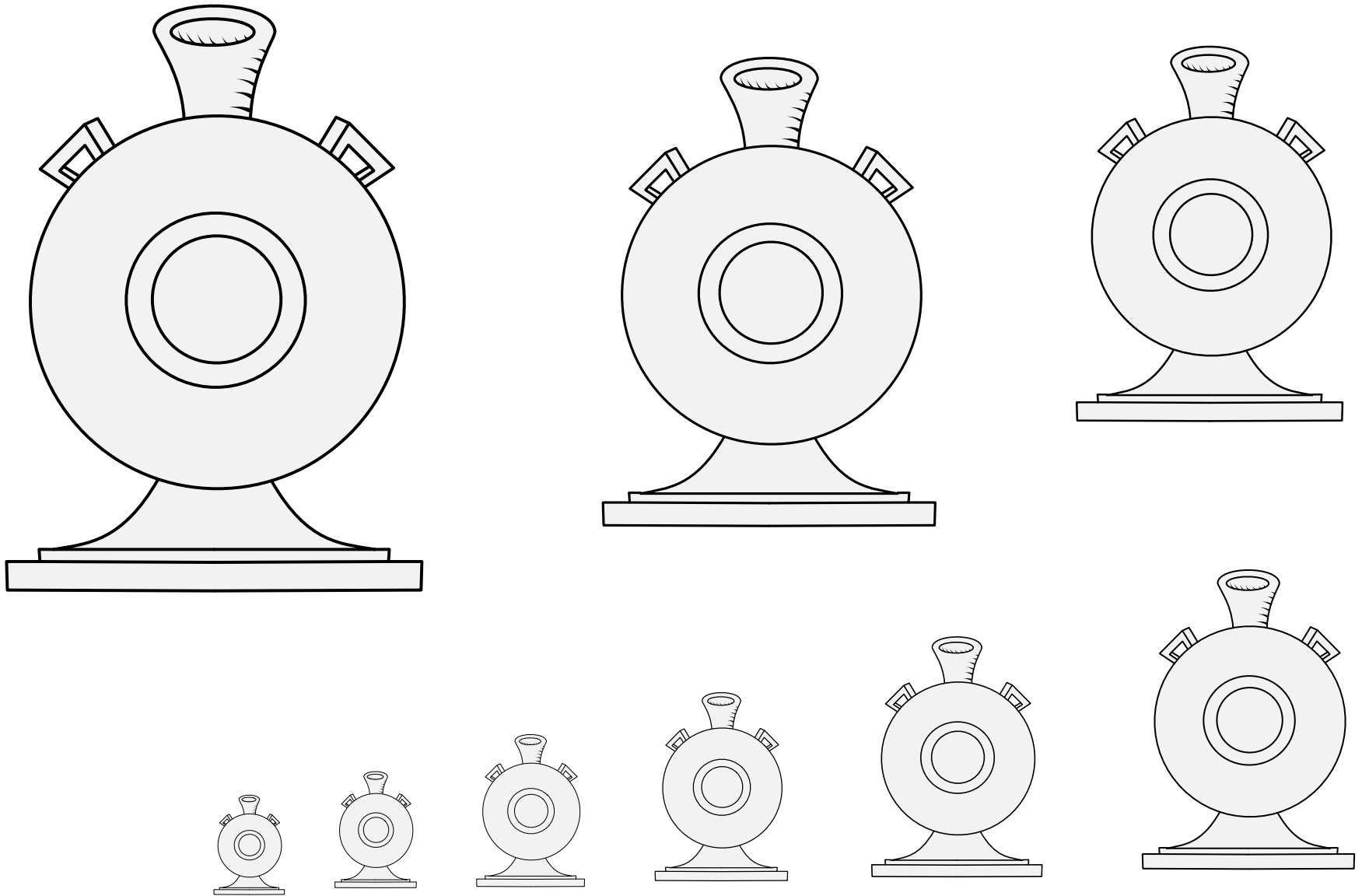

A narrow-necked container for carrying liquid.

Default orientation: opening to chief. No proper coloration.

Artist: Jon Cheseby. Adapted from Scheibler Armorial.
(From Plate 177, arms of Herbertshofen.)

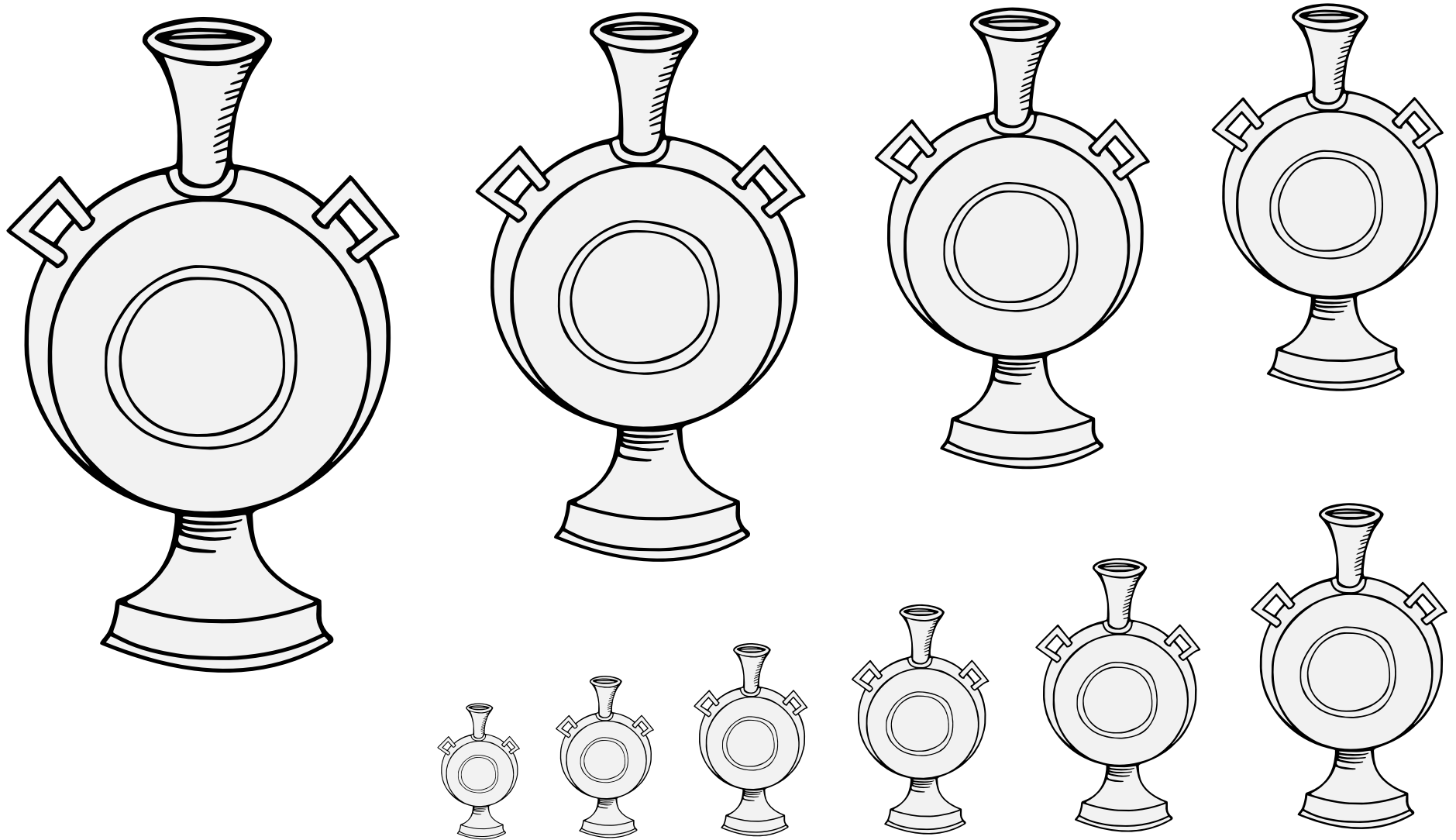

A narrow-necked container for carrying liquid.

Default orientation: opening to chief. No proper coloration.

Source: Scheibler Armorial. Artist unknown. (Arms of Herbertshofen, page 177.)

Adapted by Jessimond of Emerickeskepe.

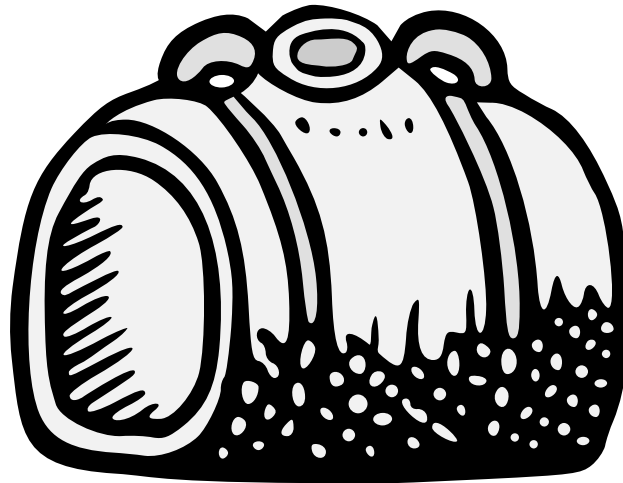
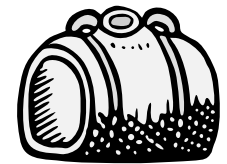
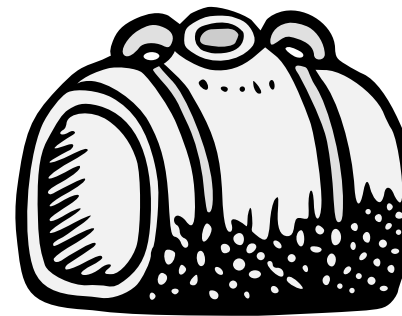
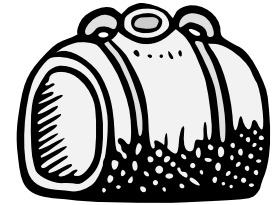
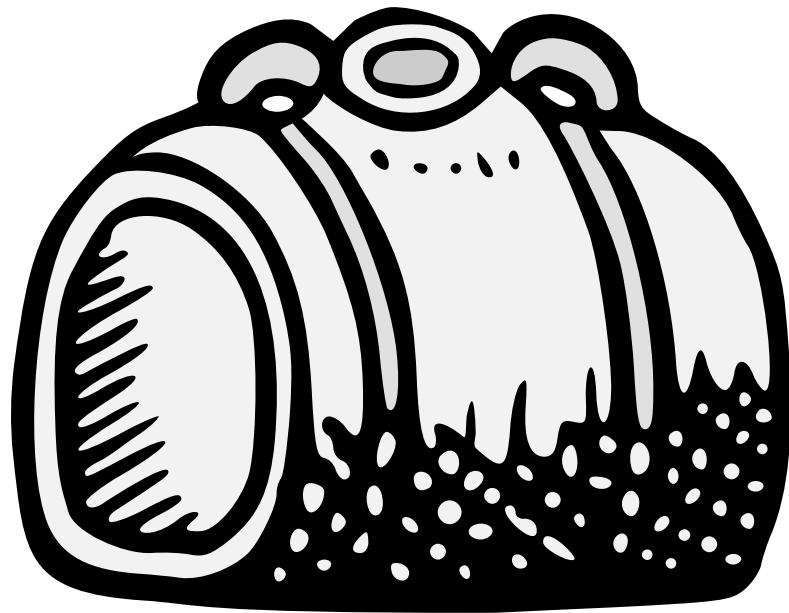

A portable container for water or wine.

Default orientation: opening to chief. No proper coloration.

Source: The Armes of All the Cheife Corporatons.

Adapted by Mathghamhain Ua Ruadháin.

(From the arms of the Bottle Makers and Horners' Company.)

Costrel, Leather 14.50

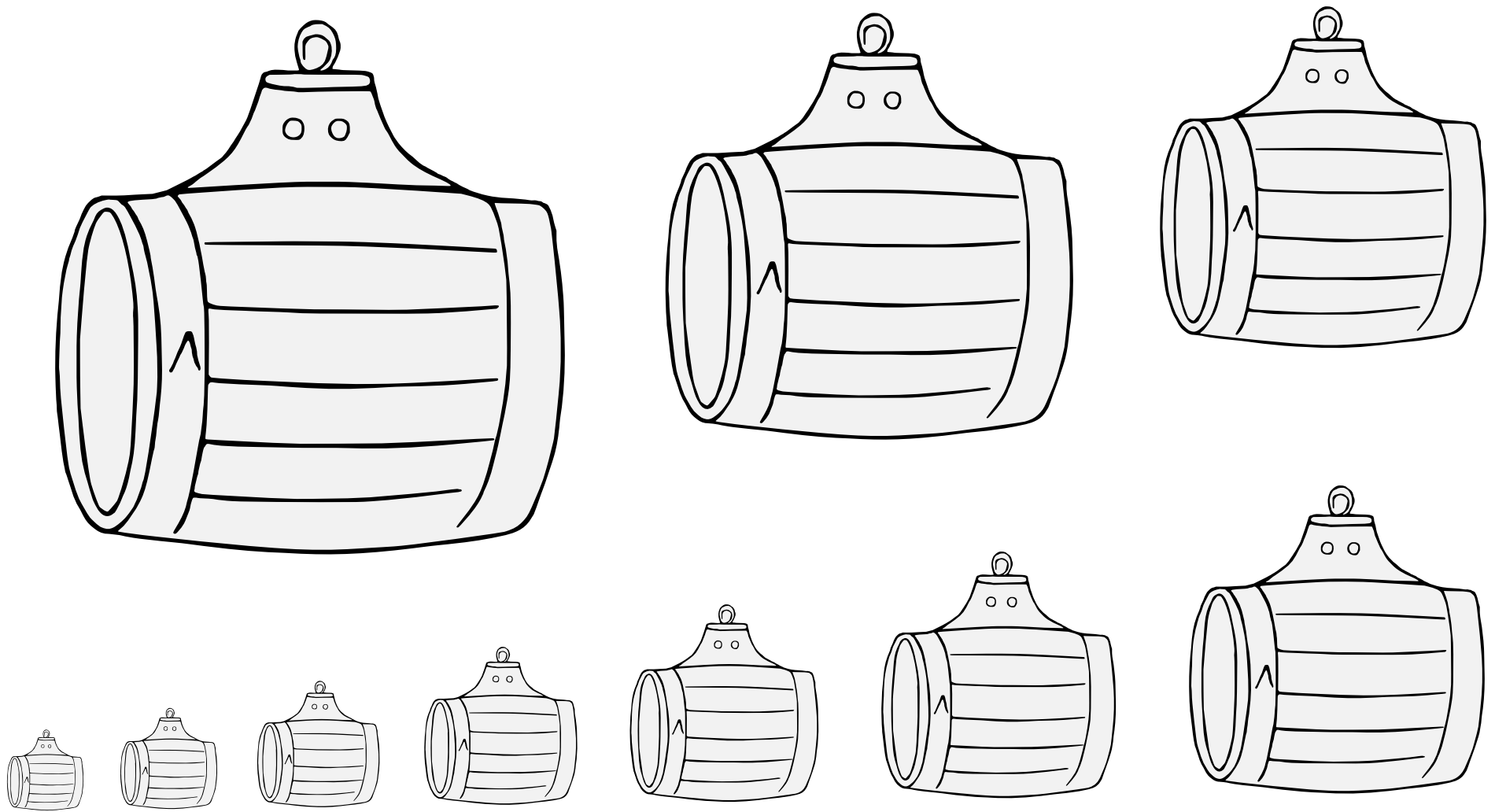

A small portable barrel with a carrying handle and a bung to drink from.

Default orientation: opening to chief. No proper coloration.

Source: Wappenbuch der Arlberg-Bruderschaft. Artist: Vigil Raber.
(Page 832.) Adapted by Jessimond of Emerickeskepe.

Costrel, Wooden 14.51

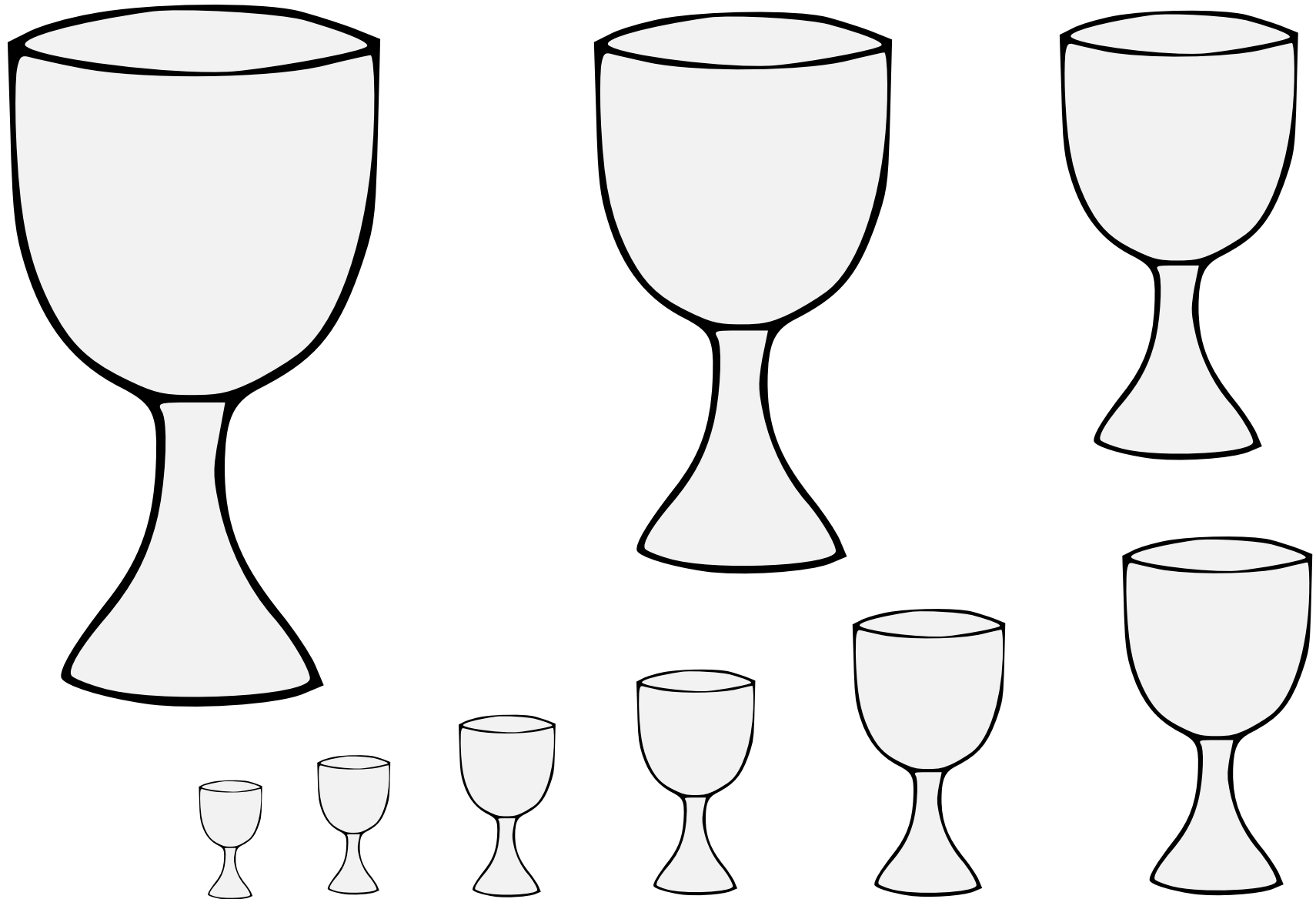

A container for drinking liquids.

Default orientation: upright. No default coloration unless the material is blazoned.

Source: Pennsic Traceable Art. Artist unknown.

Cup (1) 14.52

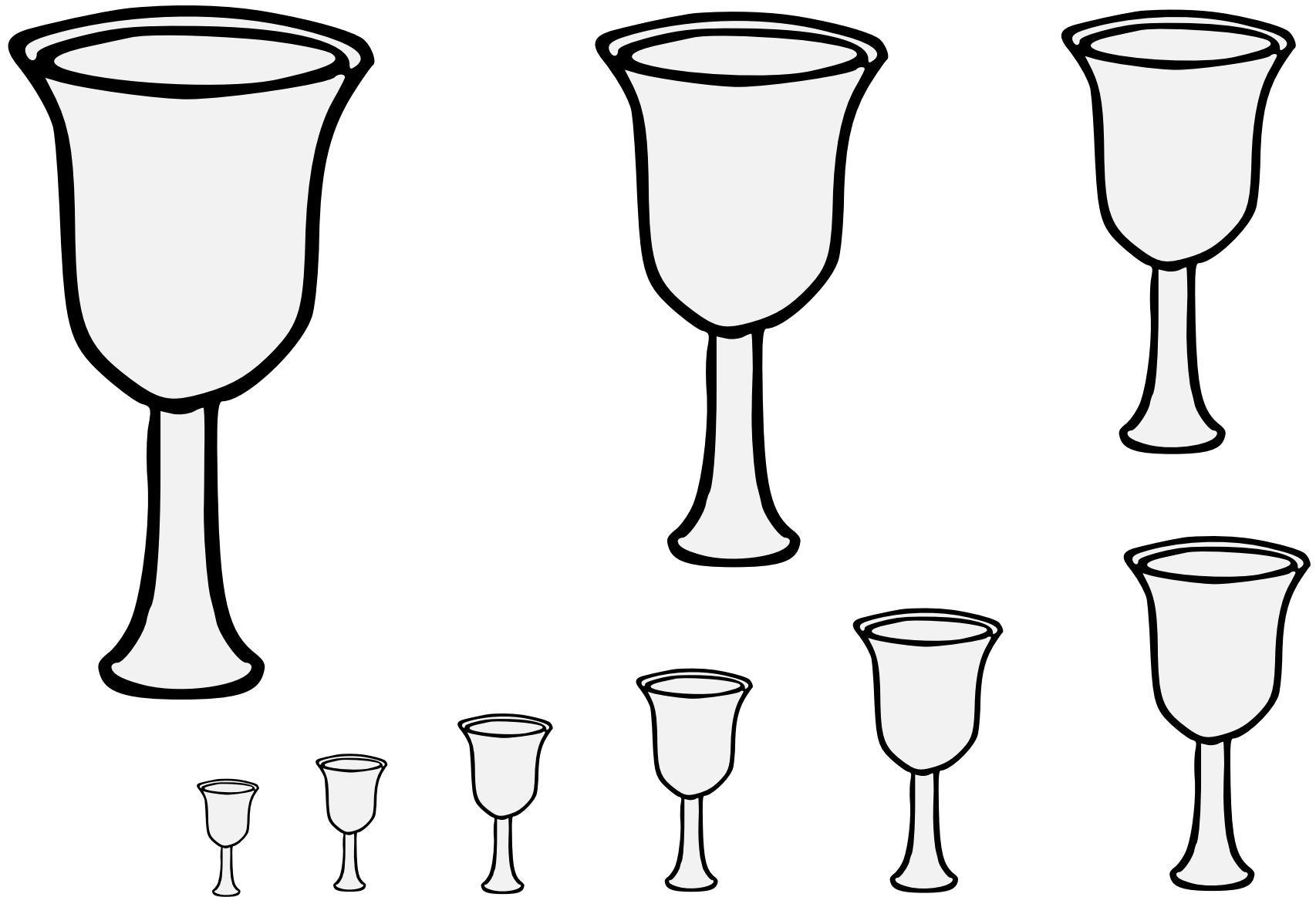

A container for drinking liquids.

Default orientation: upright. No default coloration unless the material is blazoned.

Source: Pennsic Traceable Art. Artist: Roana d'Evreux.

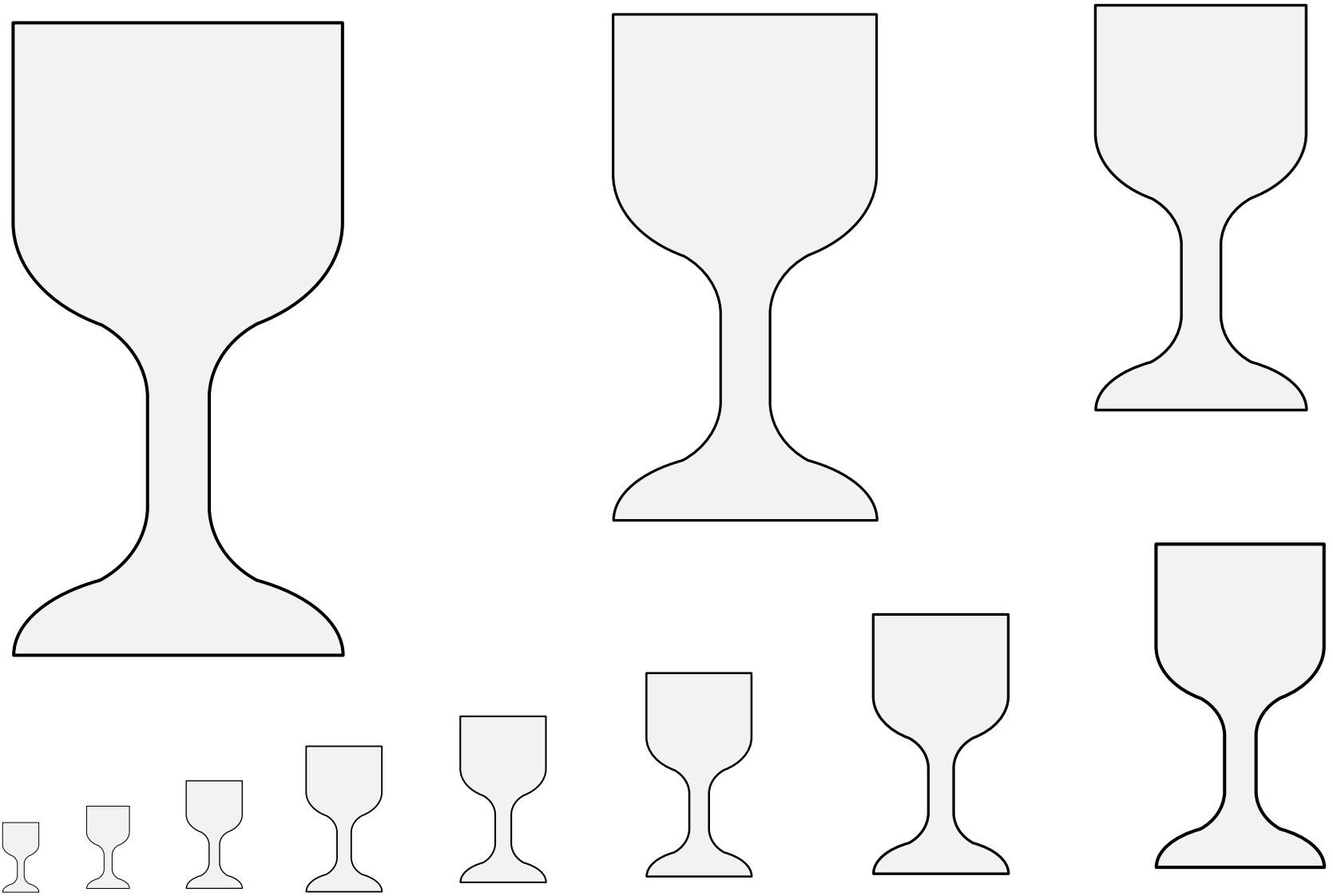

A container for drinking liquids.

Default orientation: upright. No default coloration unless the material is blazoned.

Artist: Mathghamhain Ua Ruadháin.

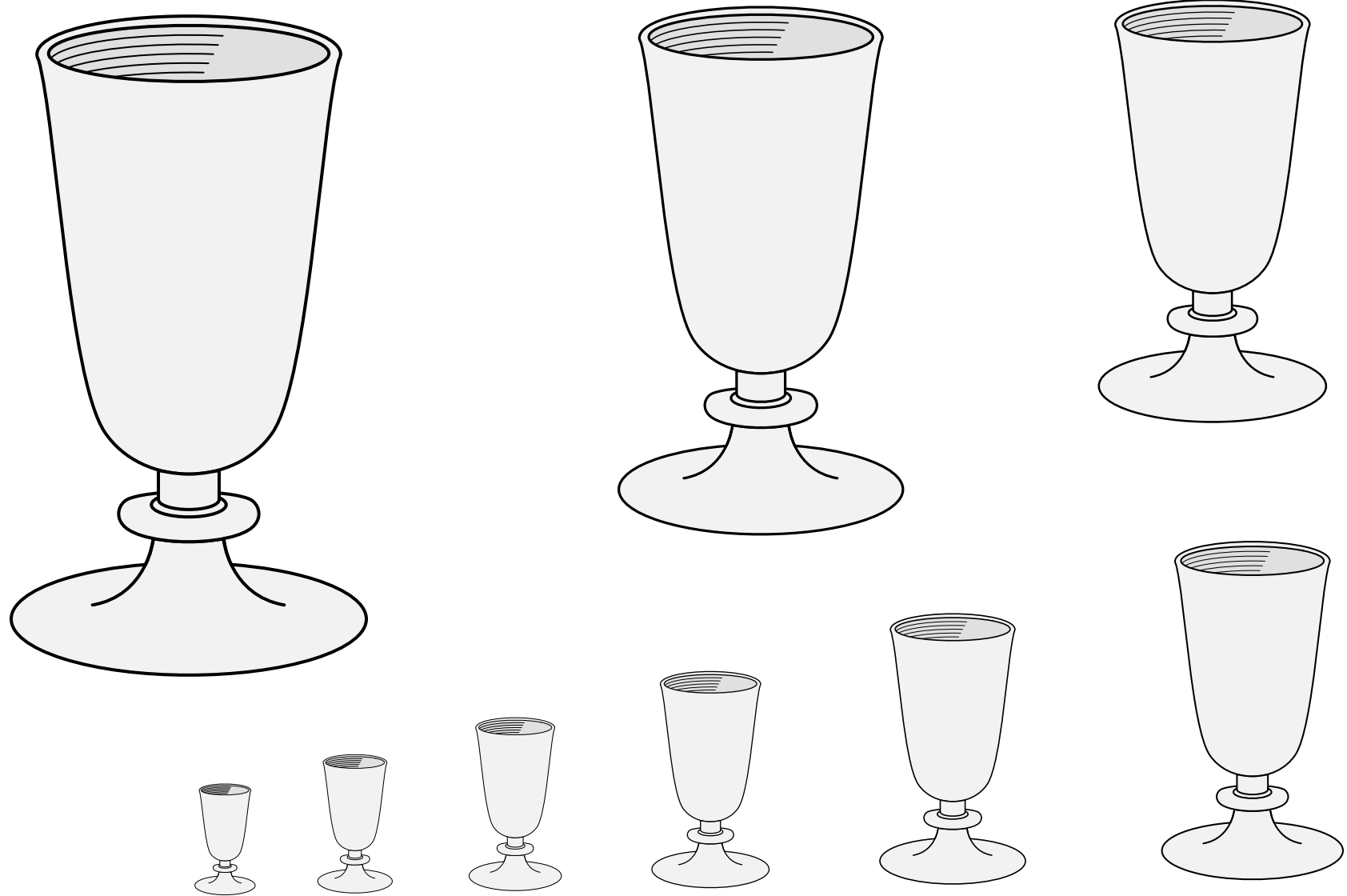

A container for drinking liquids.

Default orientation: upright. No default coloration unless the material is blazoned.

Source: Wappenbuch der Arlberg-Bruderschaft.
Artist: Vigil Raber. (Folio 67r.)

Cup (4) • 14.55

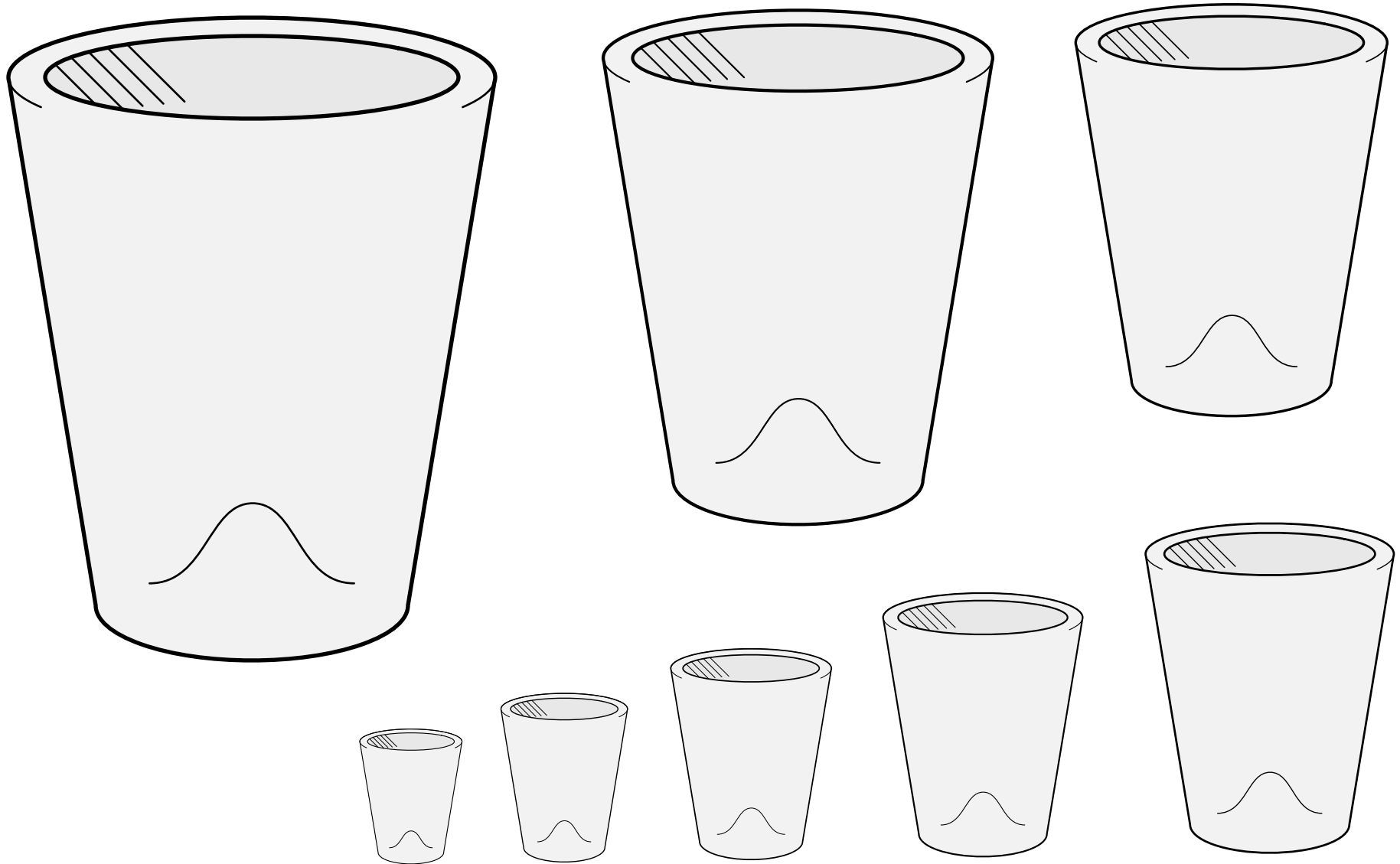

A container for drinking liquids.

Default orientation: upright. No default coloration unless the material is blazoned.

Source: Stemmario Trivulziano. Artist: Gian Antonio da Tradate.
(Arms of di Moiolis, p 221.)

Cup (5) 14.56

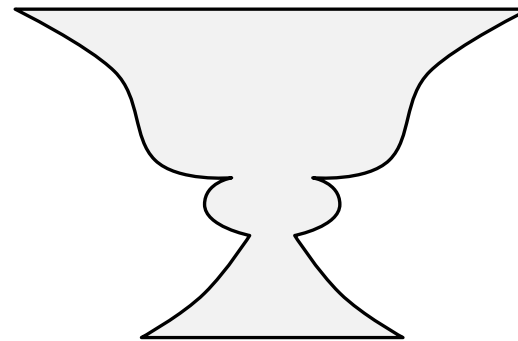
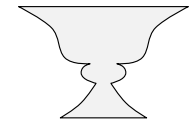
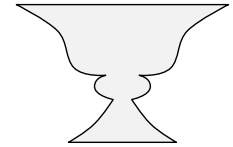
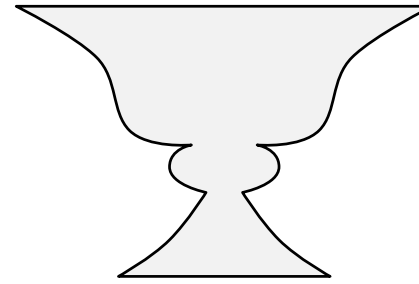
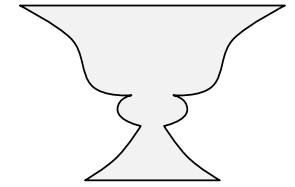
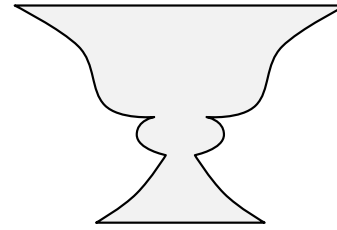
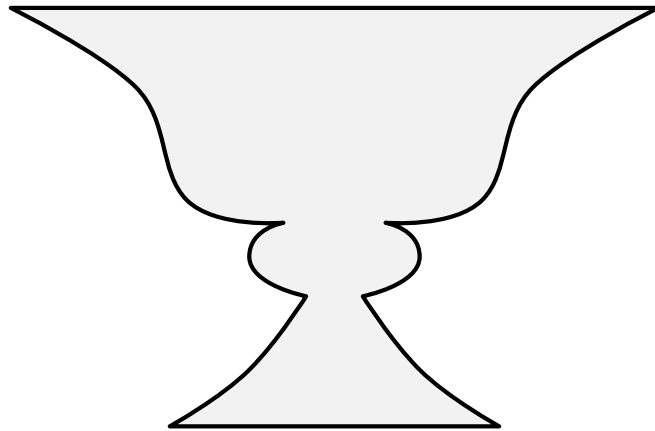
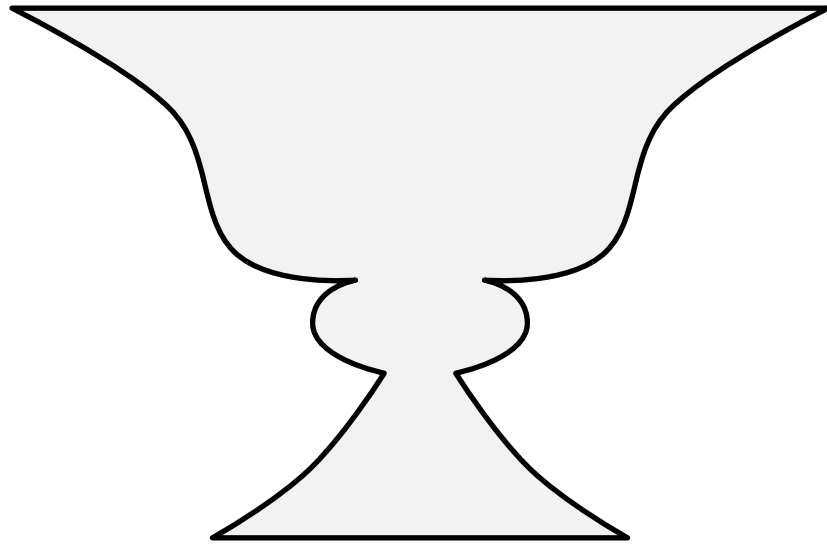

A container for drinking liquids.

Default orientation: upright. No default coloration unless the material is blazoned.

Source: Mamluk Emblems Online Corpus. Artist unknown.

(Adapted from a photograph of the facade of a ruined house in Aleppo, dated to before 1497, depicting the emblem of Qānṣūh al-Yaḥyāwī.)

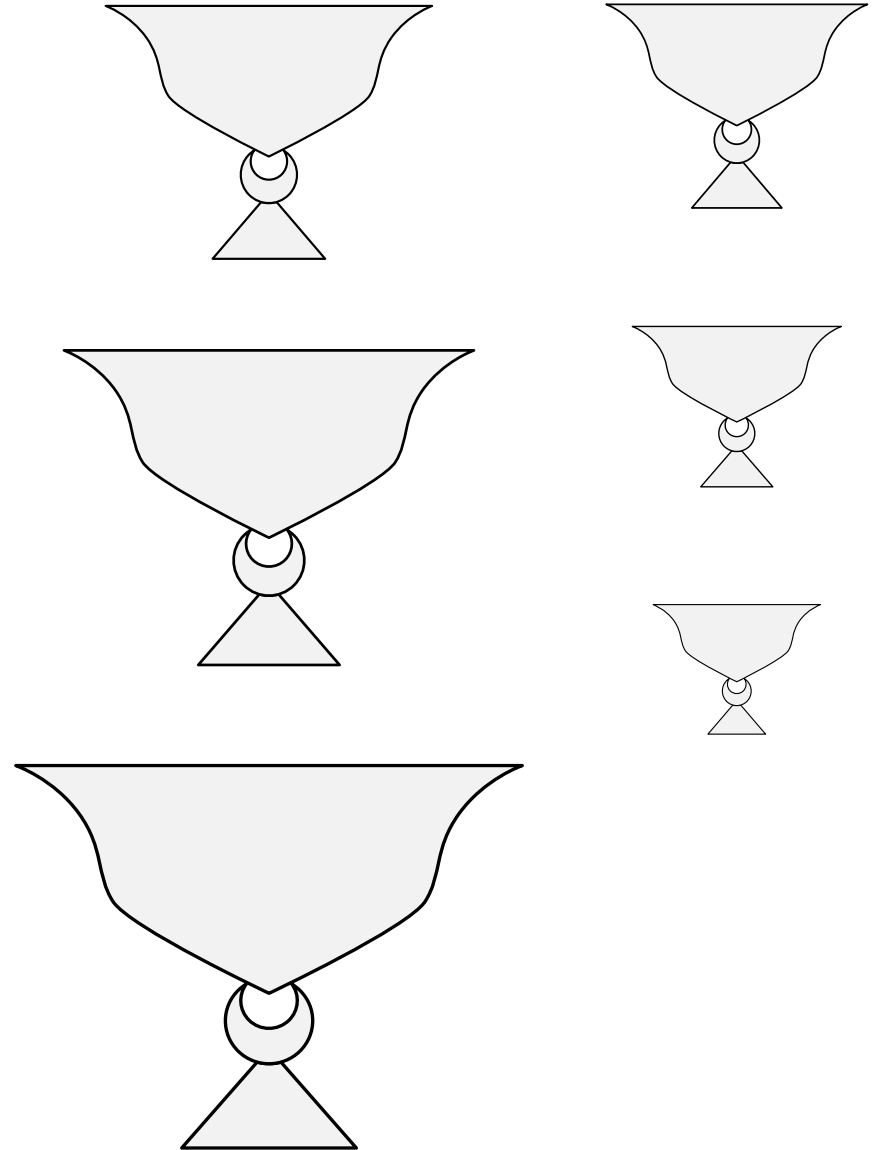
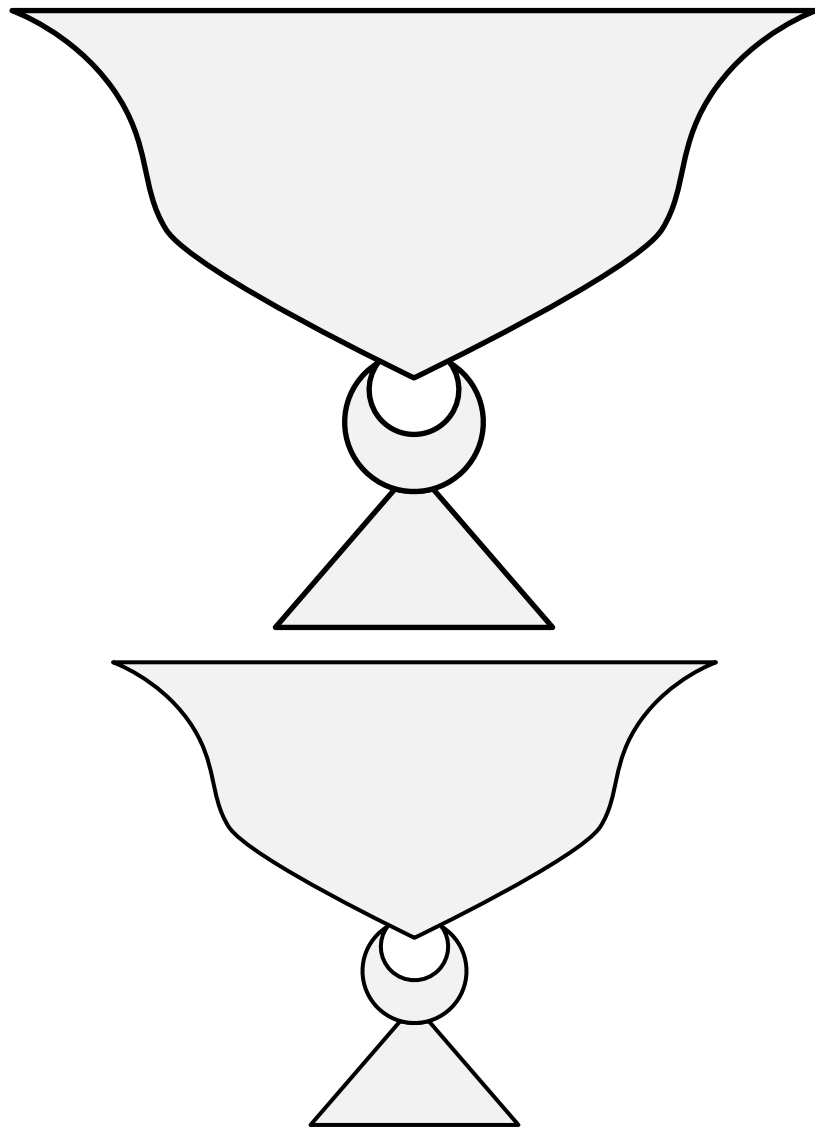

A container for drinking liquids.

Default orientation: upright. No default coloration unless the material is blazoned.

Source: Mamluk Emblems Online Corpus. Artist unknown.

(Adapted from a photograph of the Caravanserai of Yūnus al-Dawādār in Gaza City, Palestine, dated to 1387, depicting the emblem of Amir Yunis Ibn ‘Abdallah al-Nawruzi.)

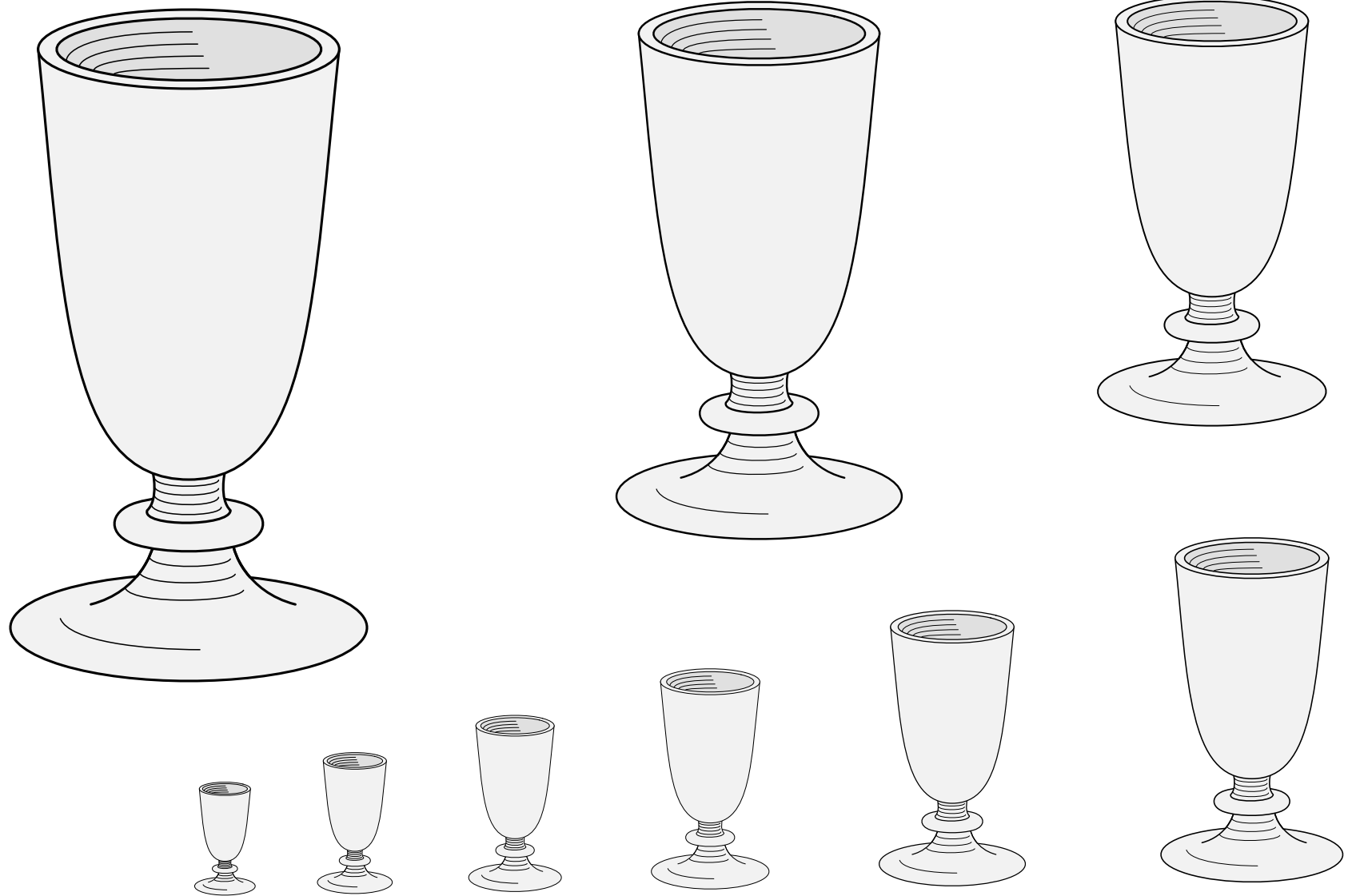

A container for drinking liquids.

Default orientation: upright. No default coloration unless the material is blazoned.

Source: Wappenbuch der Arlberg-Bruderschaft.

Artist: Vigil Raber. (Page 141.)

Cup (8) 14.59



A container for drinking liquids.

Default orientation: upright. No default coloration unless the material is blazoned.

Source: Histoire du Verre L'Antiquite. Artist unknown.
(Adapted from a photo of a extant glass made circa 1500.)

Cup (9) 14.60



A container for drinking liquids.

Default orientation: upright. No default coloration unless the material is blazoned.

Cup (10) • 14.61

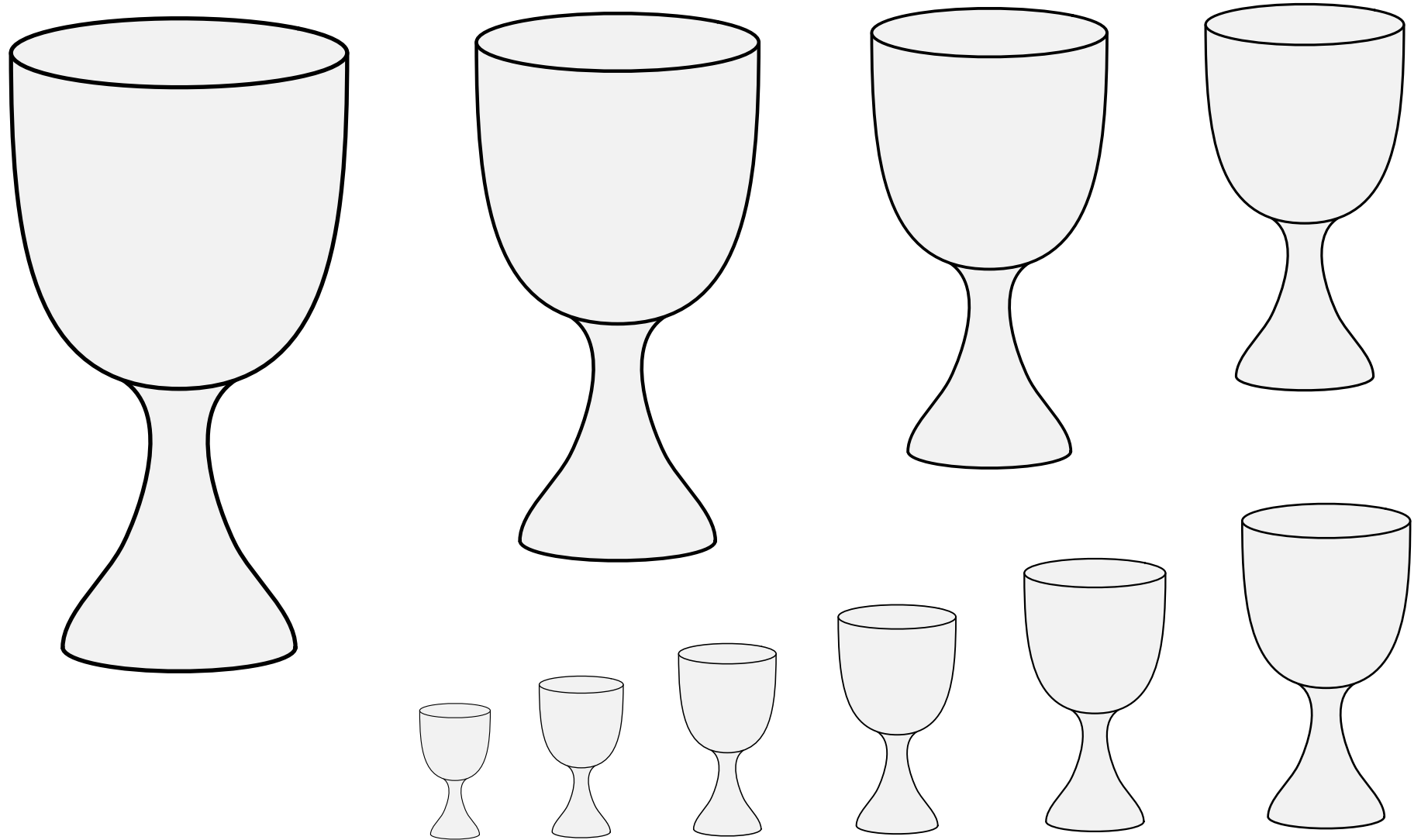

A container for drinking liquids.

Default orientation: upright. No default coloration unless the material is blazoned.

Source: Pennsic Traceable Art. Artist unknown. Adapted by Mathghamhain Ua Ruadháin.

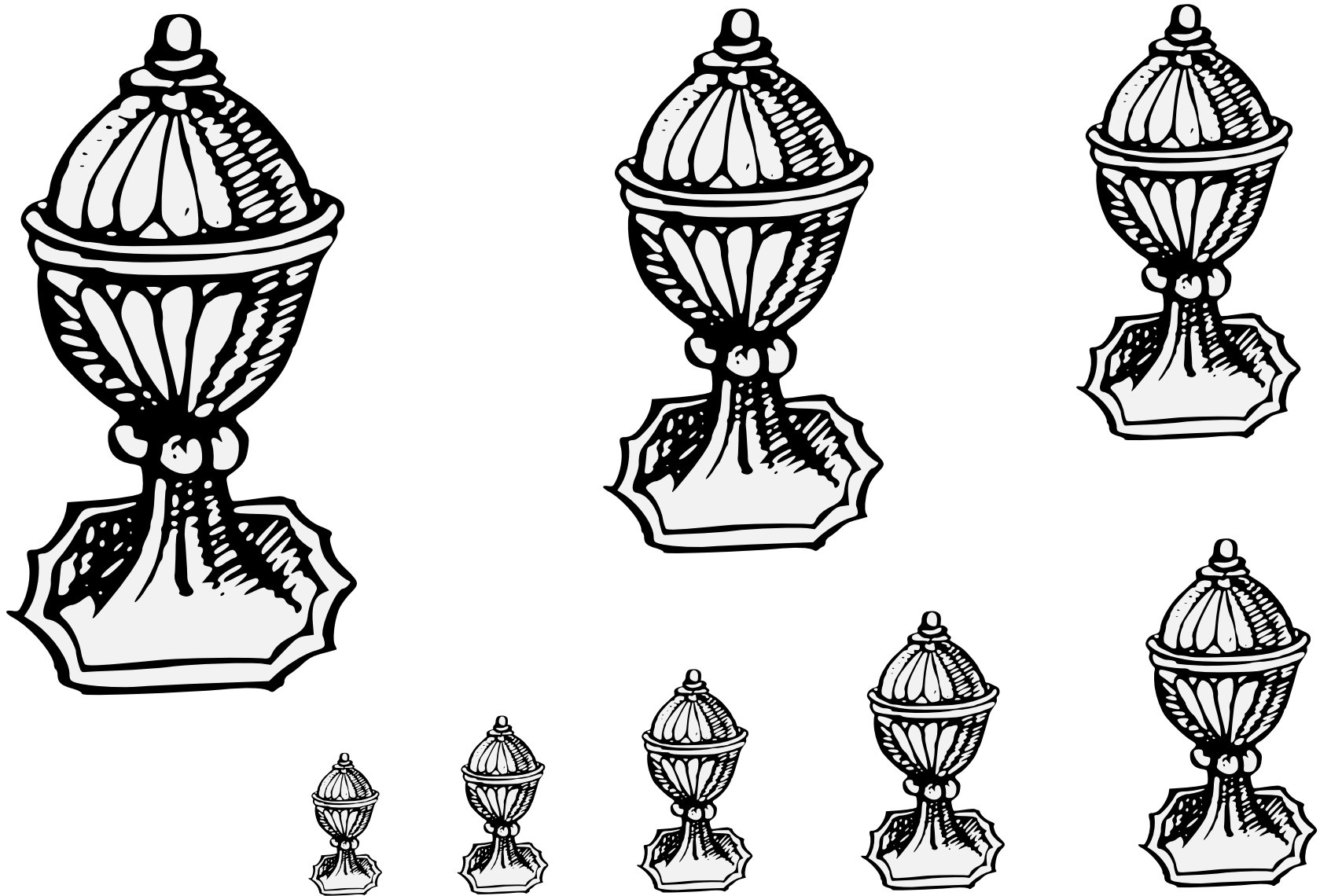

A container for drinking liquids.

Default orientation: upright. No default coloration unless the material is blazoned.

Source: Funeral Arms and Commissions for Visitations.
Artist unknown. (Page 93.)

Cup, Covered (1) 14.63

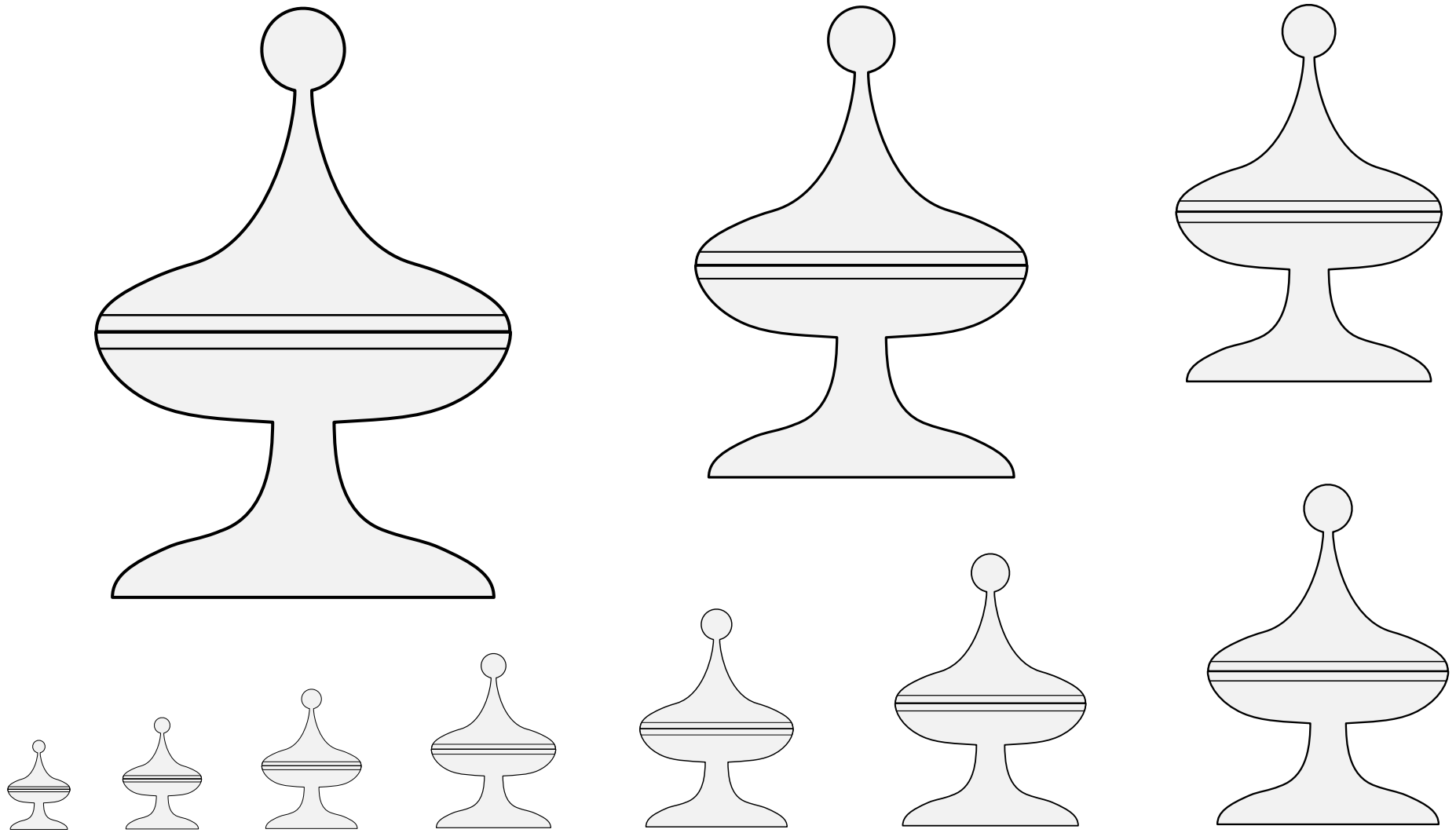

A container for drinking liquids.

Default orientation: upright. No default coloration unless the material is blazoned.

Source: Powell Roll. Artist unknown. (Folio 5v, arms of Argentine.)

Cup, Covered (2) 14.64

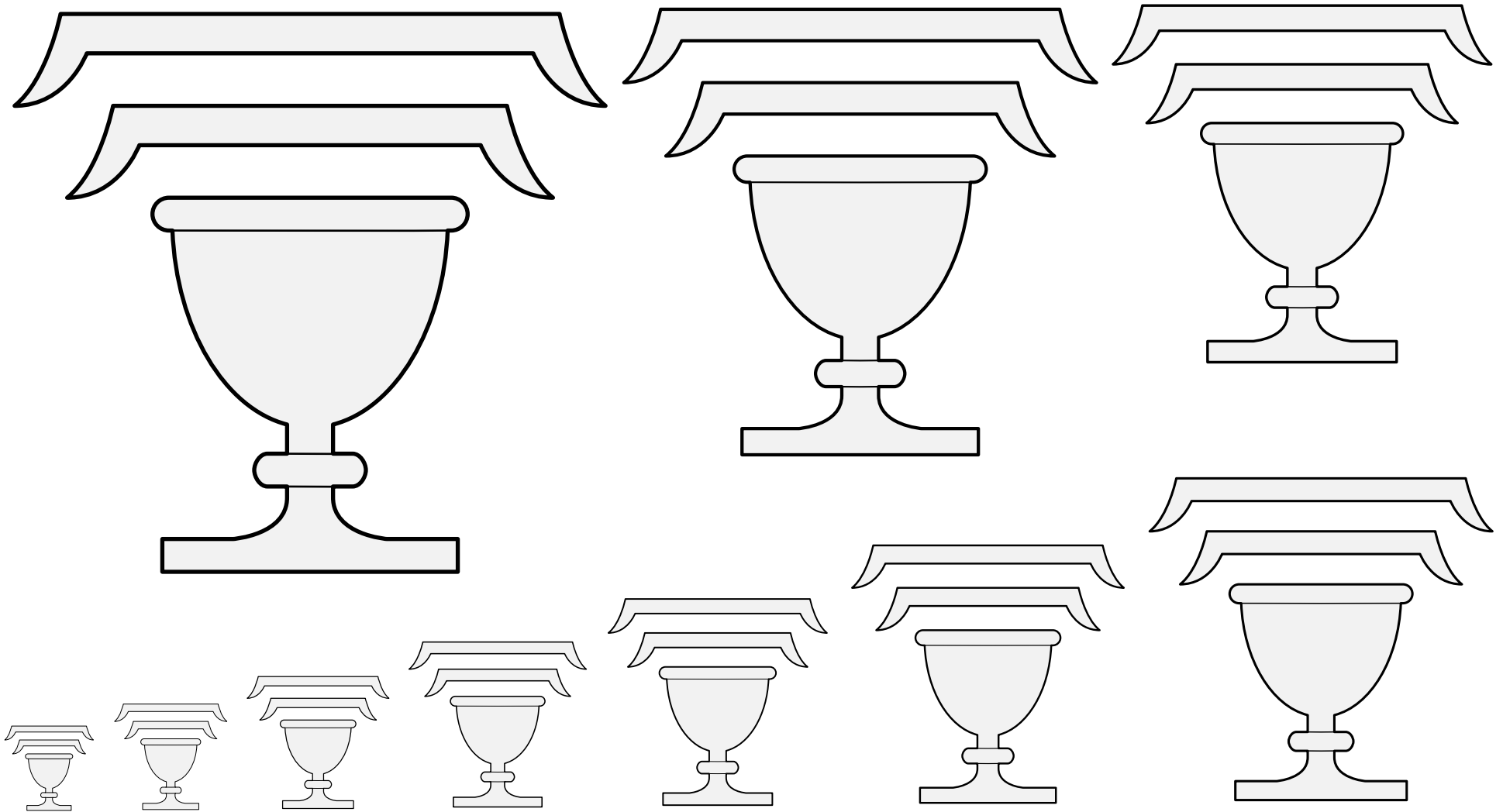

A container for drinking liquids.

Default orientation: upright. No default coloration unless the material is blazoned.

Source: BnF MS Allemand 304. Artist unknown. (Page 438.)

Cup, Covered (3) 14.65

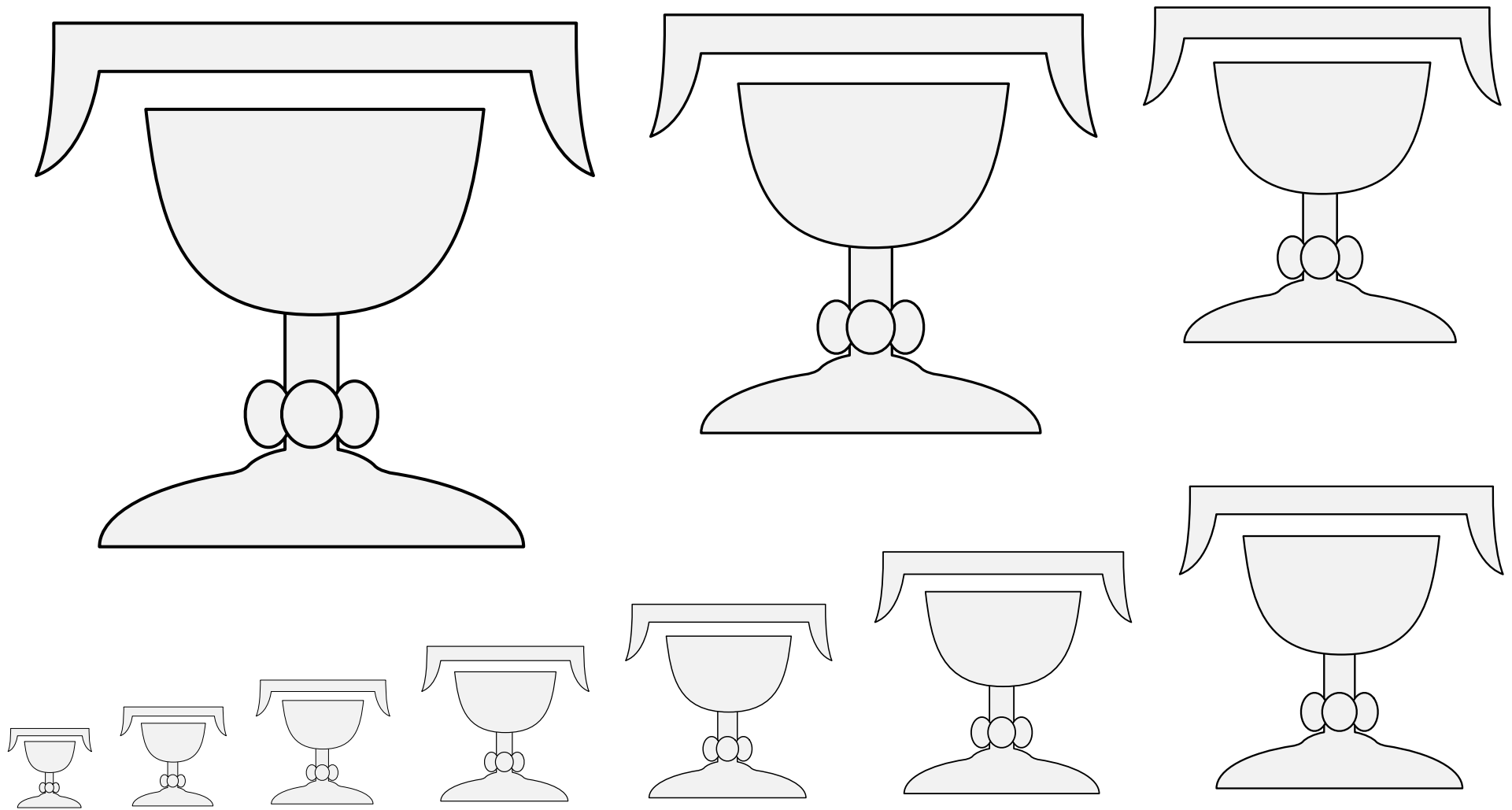

A container for drinking liquids.

Default orientation: upright. No default coloration unless the material is blazoned.

Source: BnF MS Allemand 304. Artist unknown. (Page 603.)

Cup, Covered (4) 14.66

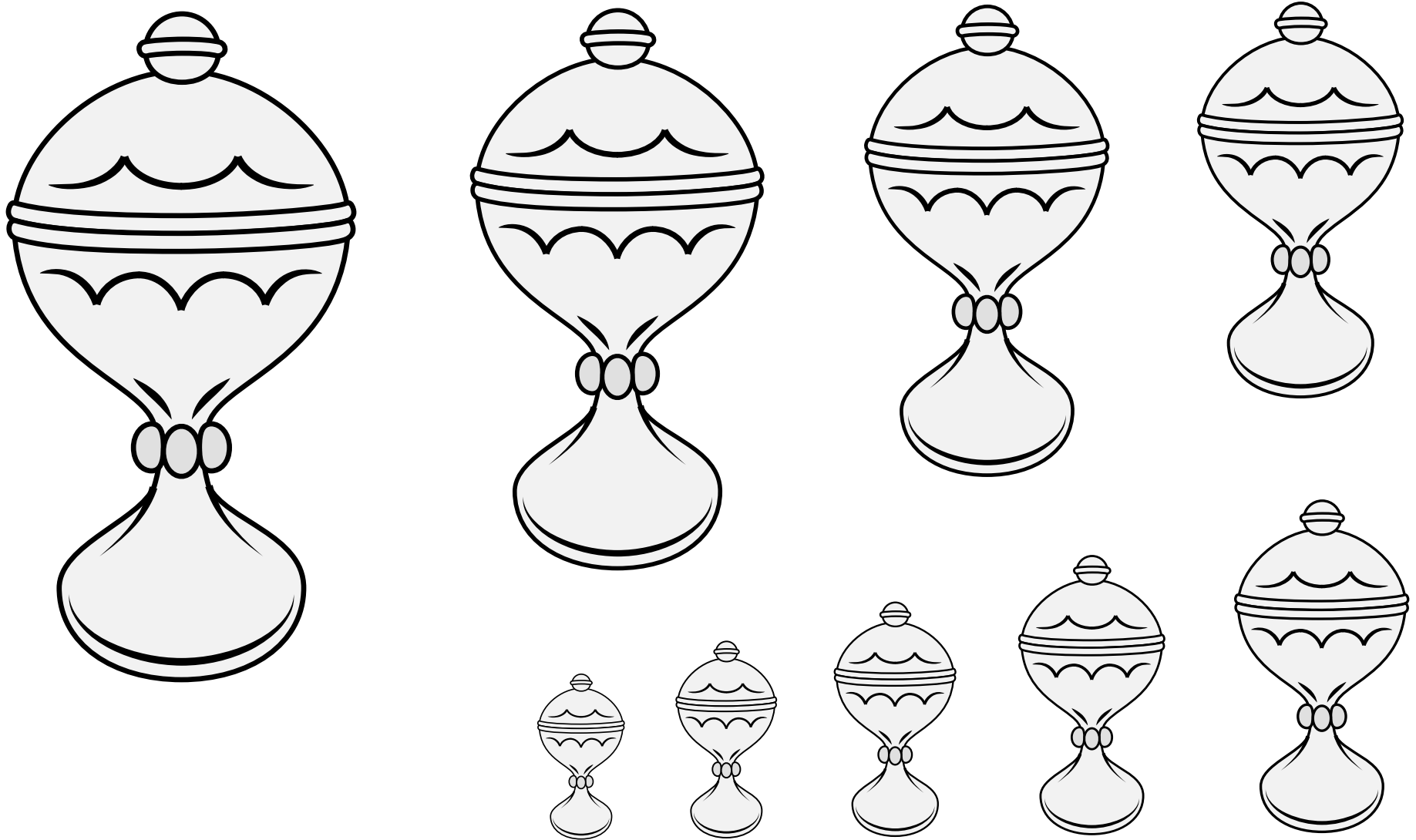

A container for drinking liquids.

Default orientation: upright. No default coloration unless the material is blazoned.

Source: WappenWiki. Artist: Joakim Spuller. Adapted by Finellach.

Cup, Covered (5) 14.67

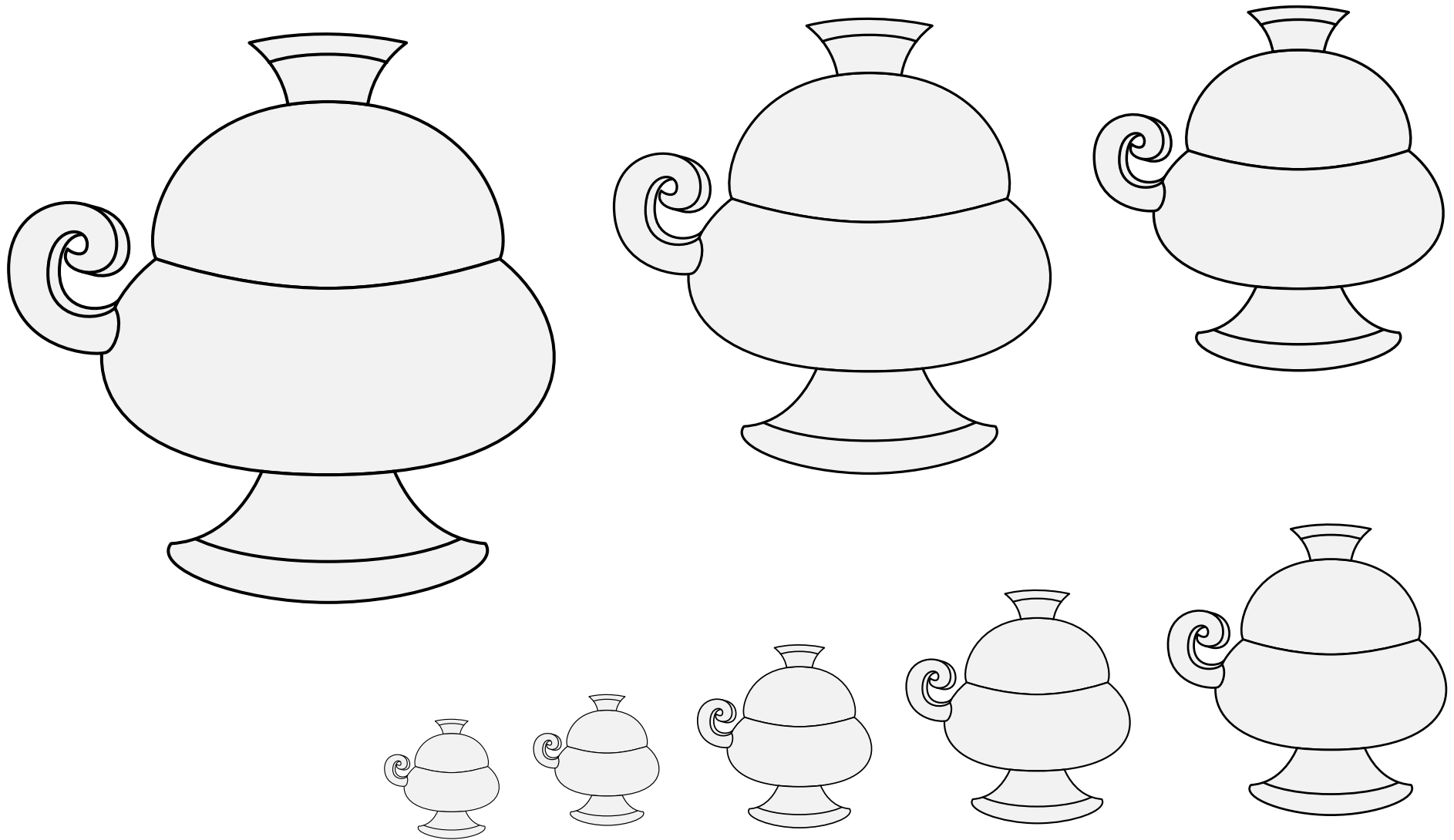

A container for drinking liquids.

Default orientation: upright. No default coloration unless the material is blazoned.

The double cup design, with a pair of cups that stacked together, was called a "doppelbecher" in German, and was associated with weddings.

Source: Wappenbuch der Arlberg-Bruderschaft.

Artist: Vigil Raber. (From page 238.)

Cup, Double (1) 14.68

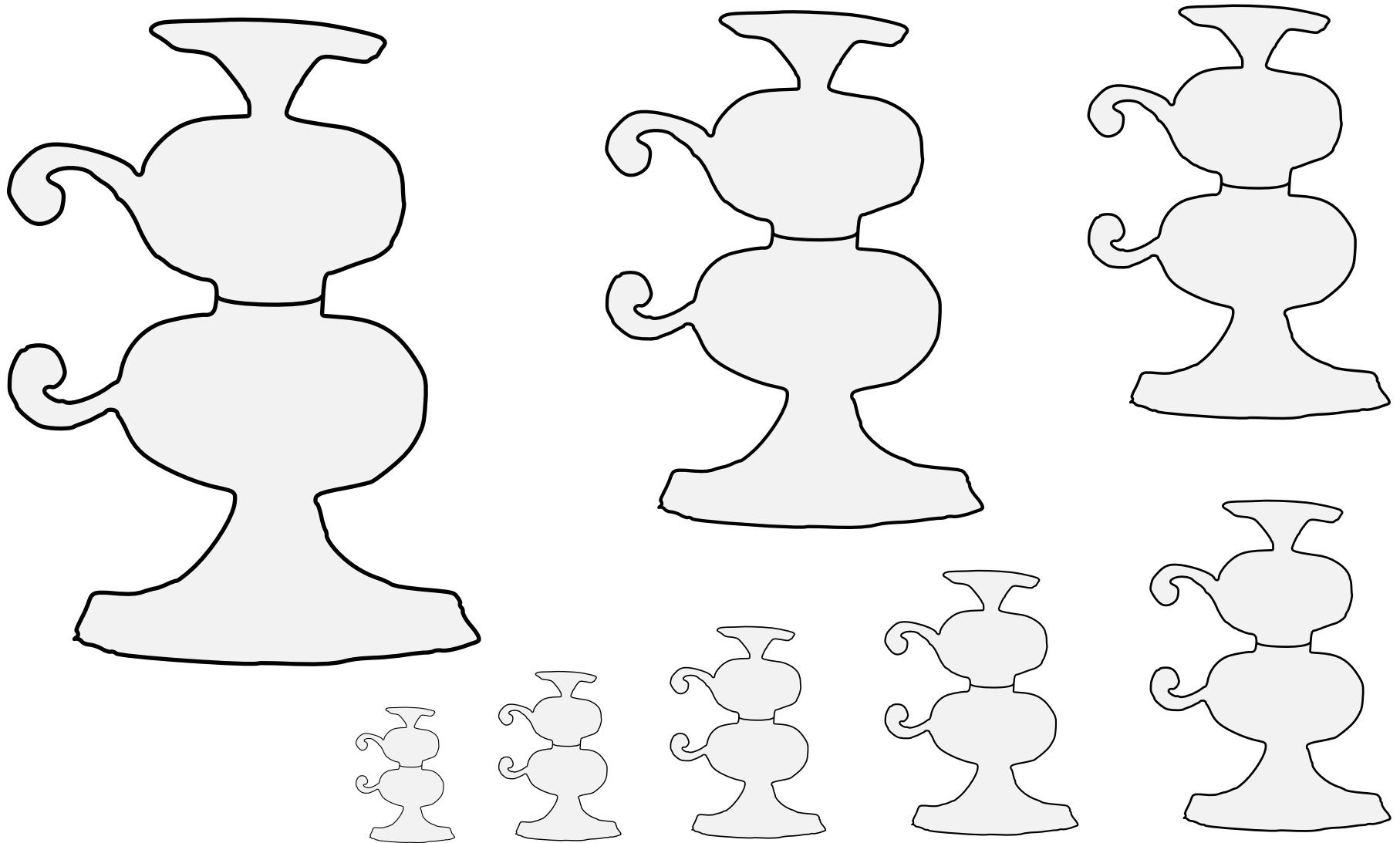

A container for drinking liquids.

Default orientation: upright. No default coloration unless the material is blazoned.

The double cup design, with a pair of cups that stacked together, was called a "doppelbecher" in German, and was associated with weddings.

Source: Neustifter Wappenbuch. Artist: Vigil Raber.
(Arms of Vollandt, page 151.)

Cup, Double (2) 14.69

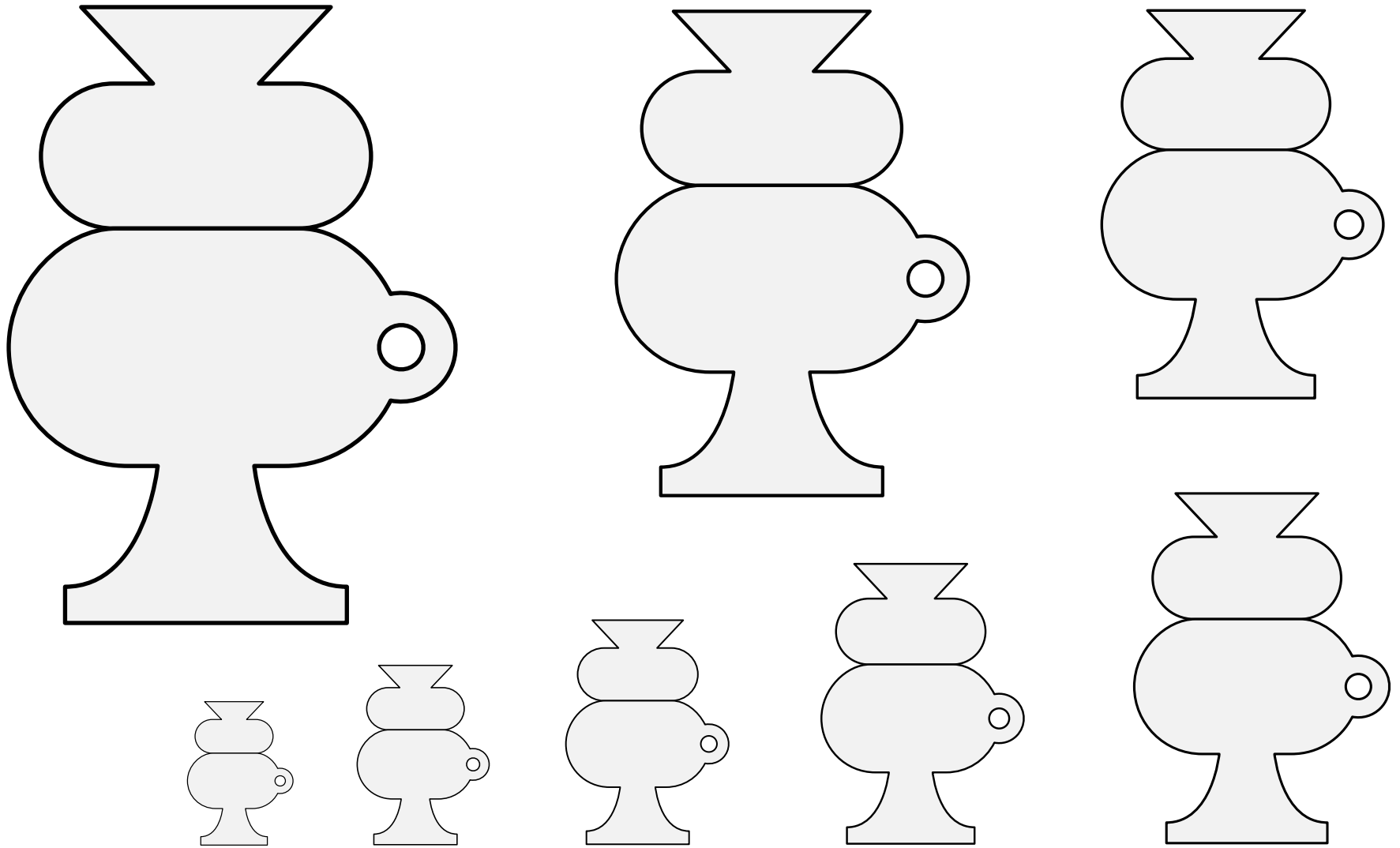

A container for drinking liquids.

Default orientation: upright. No default coloration unless the material is blazoned.

The double cup design, with a pair of cups that stacked together, was called a "doppelbecher" in German, and was associated with weddings.

Source: Zurich Roll. Artist unknown. (Folio 3r, arms of Liebeneberg.)

Adapted by Mathghamhain Ua Ruadháin.

Cup, Double (3) 14.70

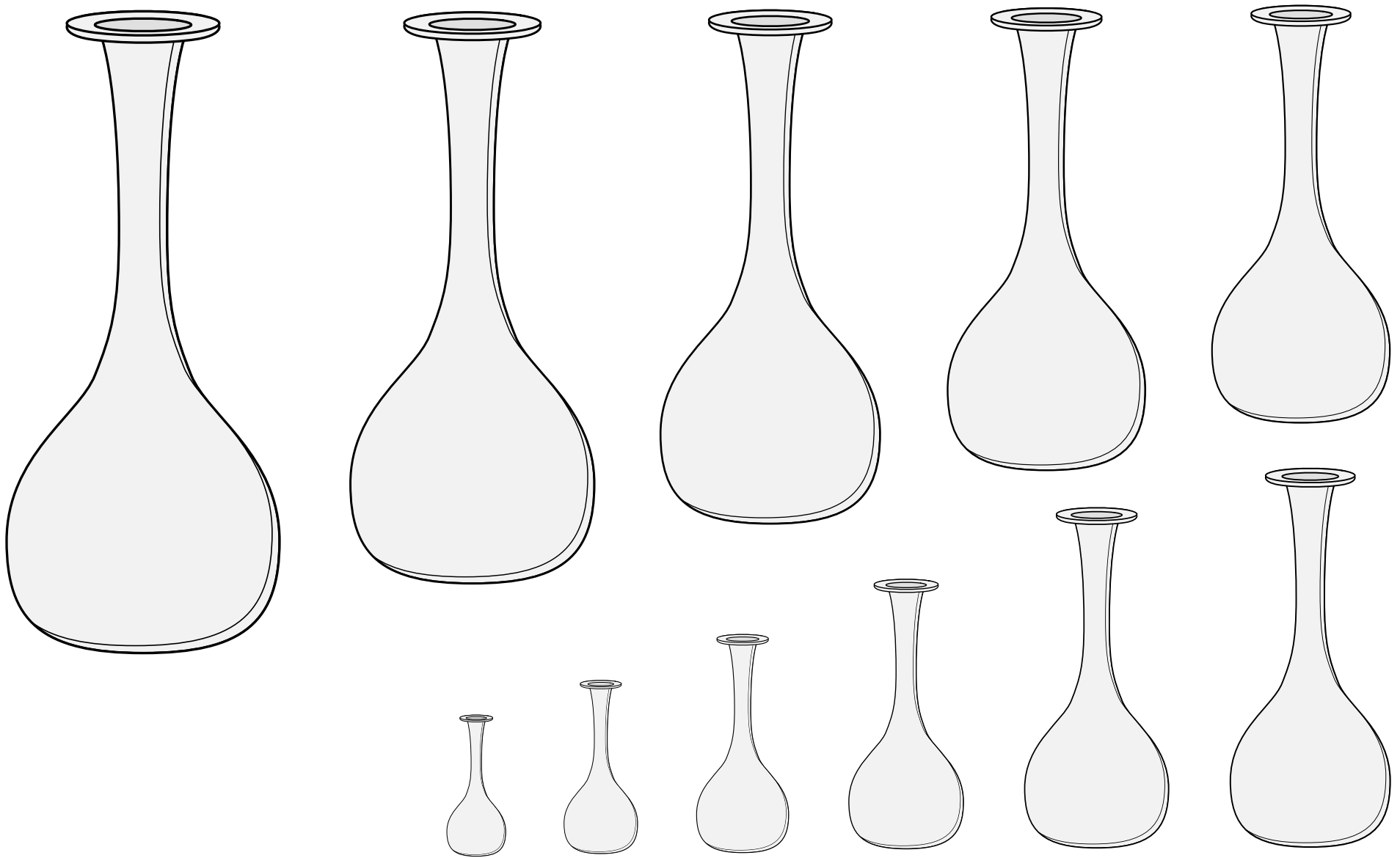

A narrow-necked container for carrying liquid.
Default orientation: opening to chief. No proper coloration.

Flask (1) 14.71

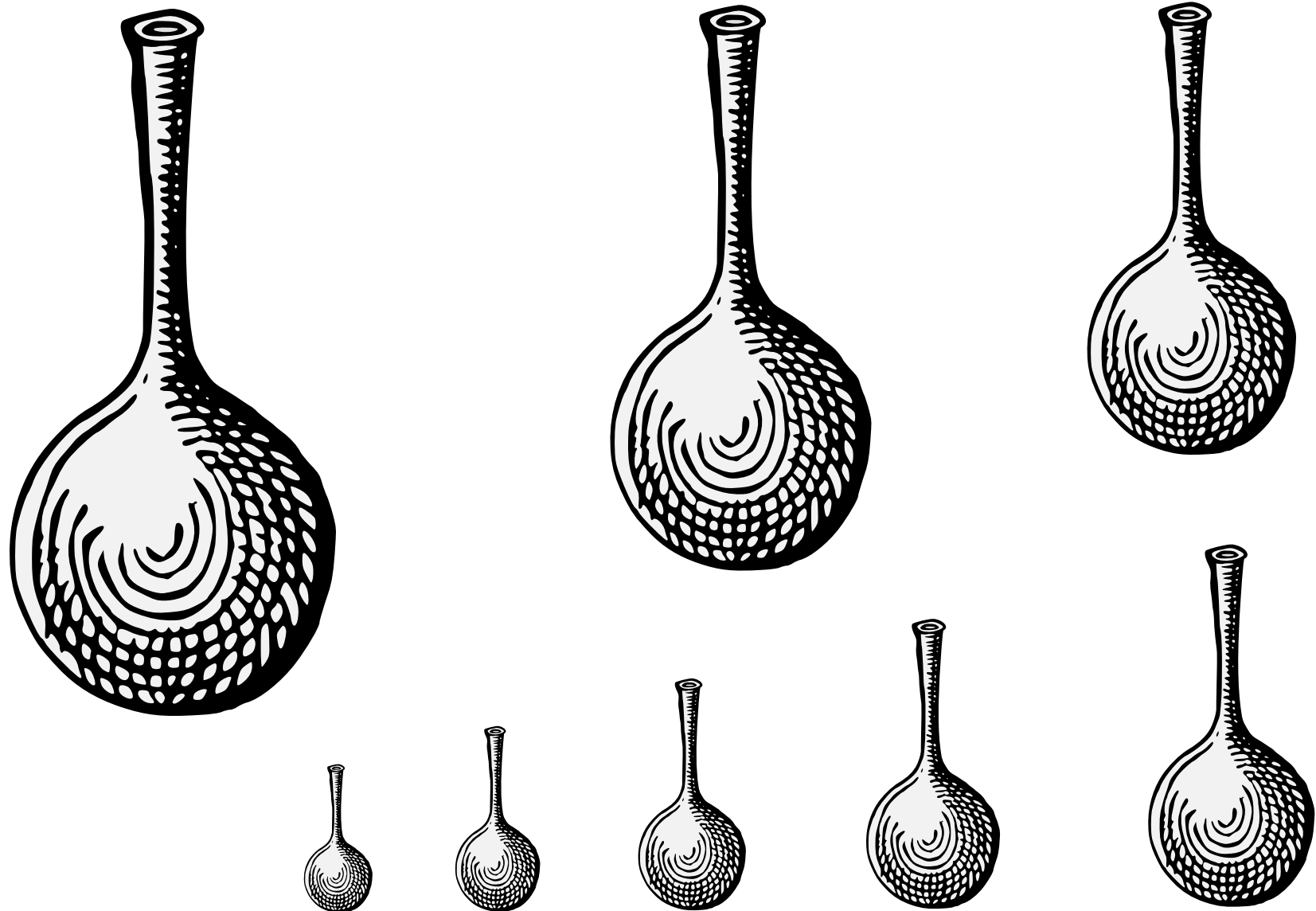

A narrow-necked container for carrying liquid.

Default orientation: opening to chief. No proper coloration.

Source: Le Blason Des Armoiries. Artist: Jérôme de Bara. (Page 132.)

Flask (2) 14.72

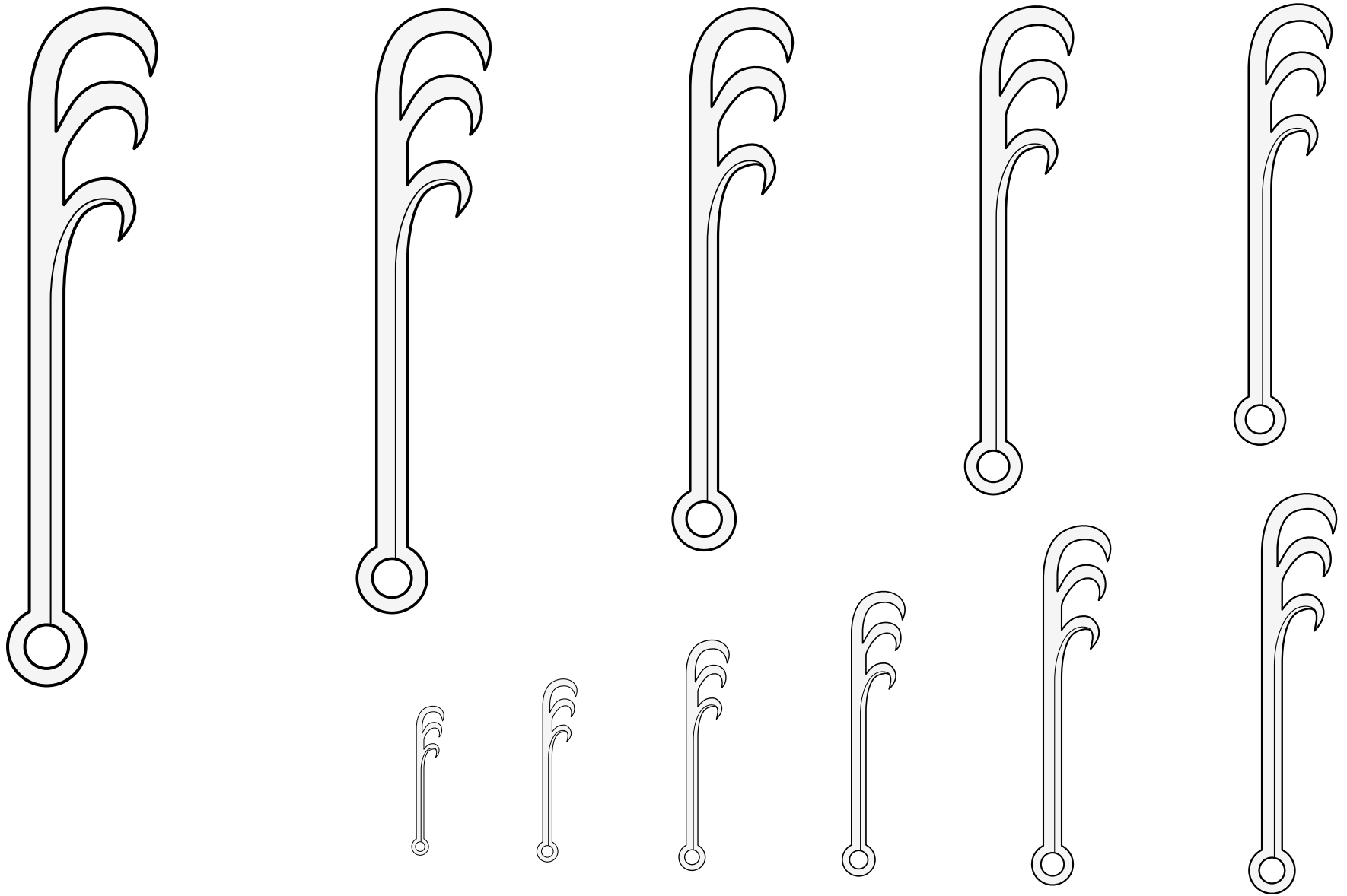

A cooking utensil used to hoist chunks of meat out of a stew pot.

Default orientation: hooks to chief. No proper coloration.

Source: A Display of Heraldry. Artist: John Guillim.
(Manuscript folio 101r.) Adapted by Iago ab Adam.

Flesh Hook 14.73

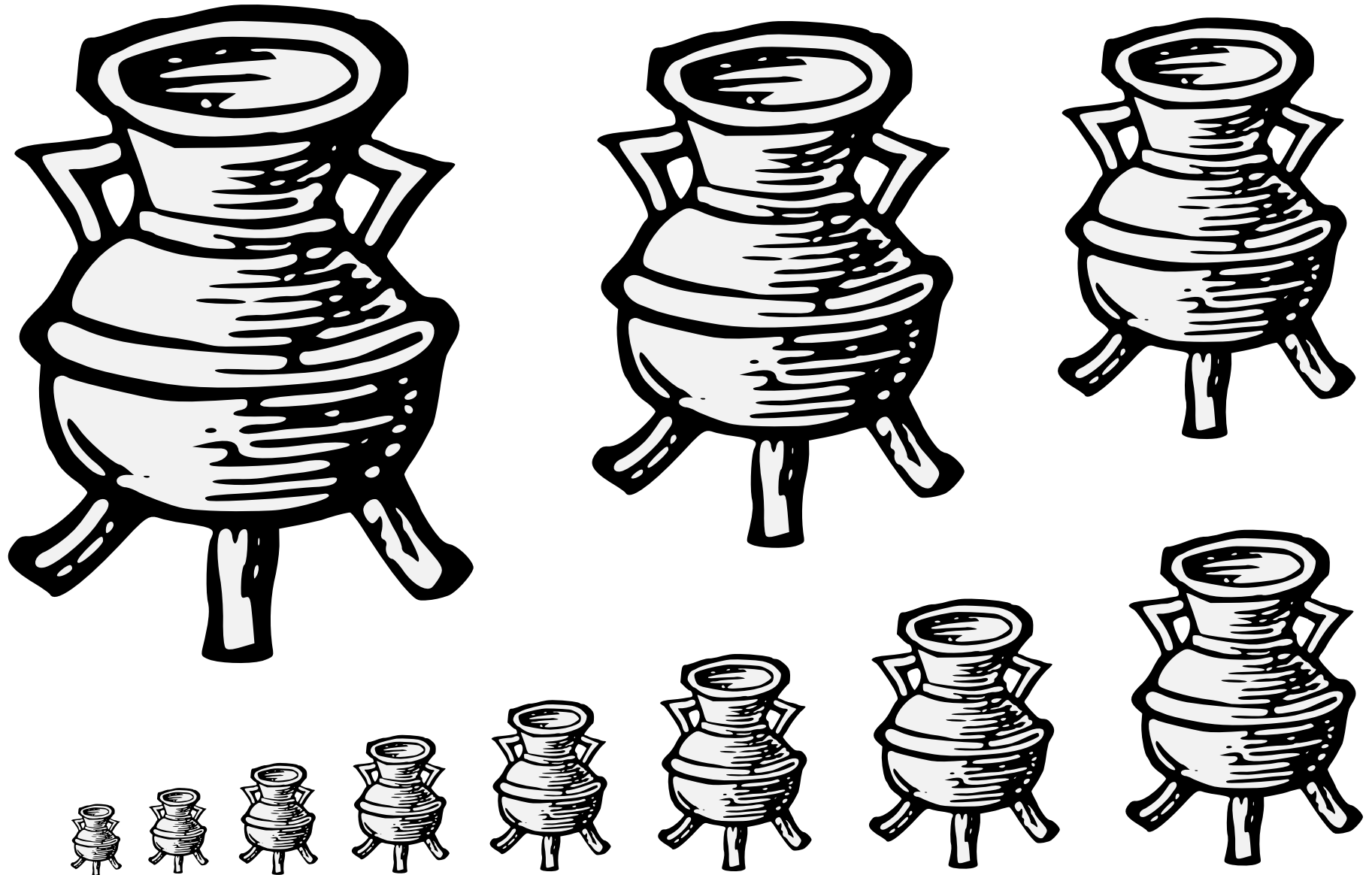

A cooking vessel in which you might boil up a stew.
Default orientation: opening to chief. No proper coloration.
Source: Guillim's Display of Heraldry. Artist unknown.

Fleshpot (1) 14.74

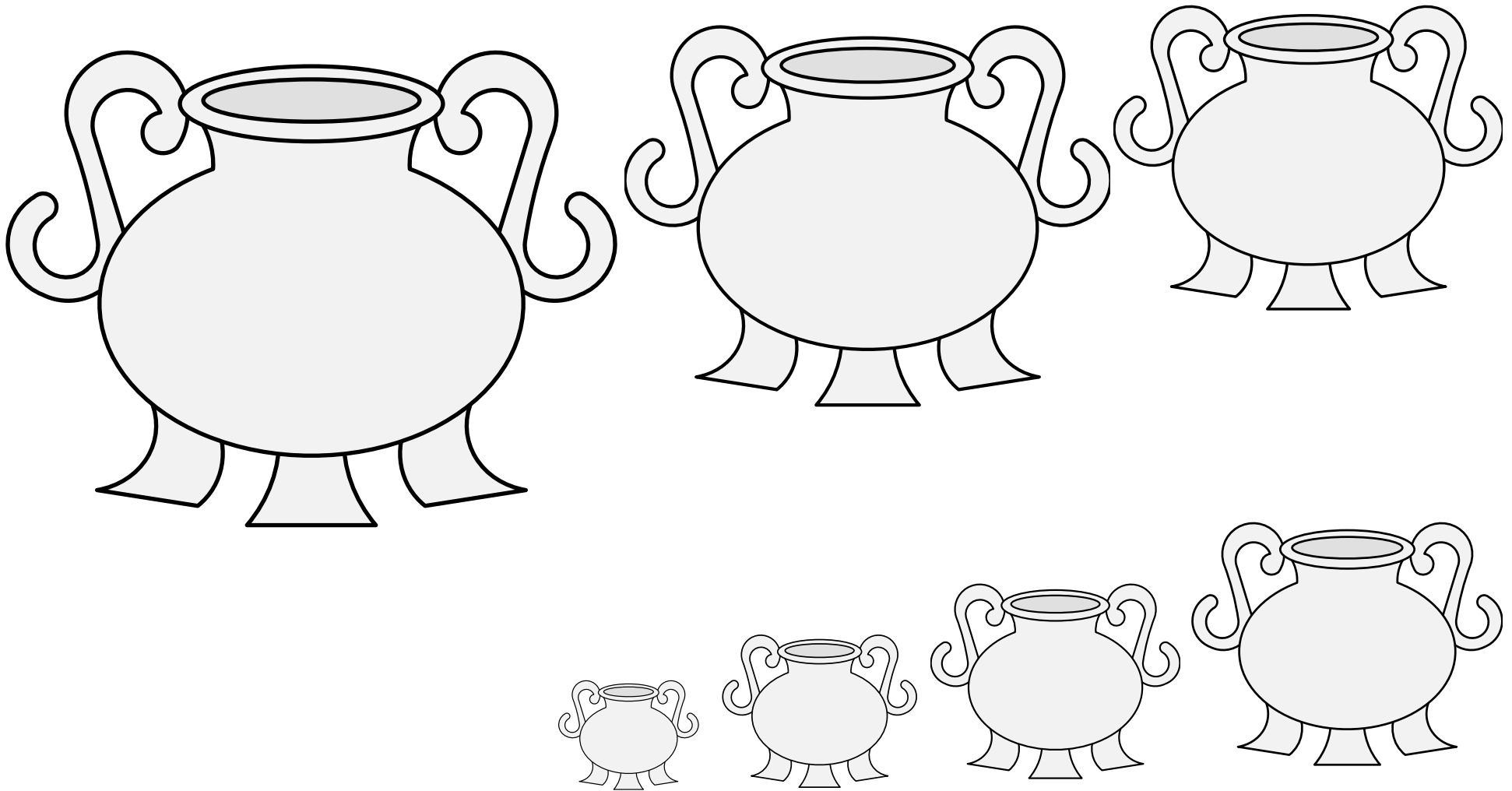

A cooking vessel in which you might boil up a stew.

Default orientation: opening to chief. No proper coloration.

Source: Viking Answer Lady SVG Images For Heraldists. Artist: Gunnvôr silfráhr.

Fleshpot (2) 14.75

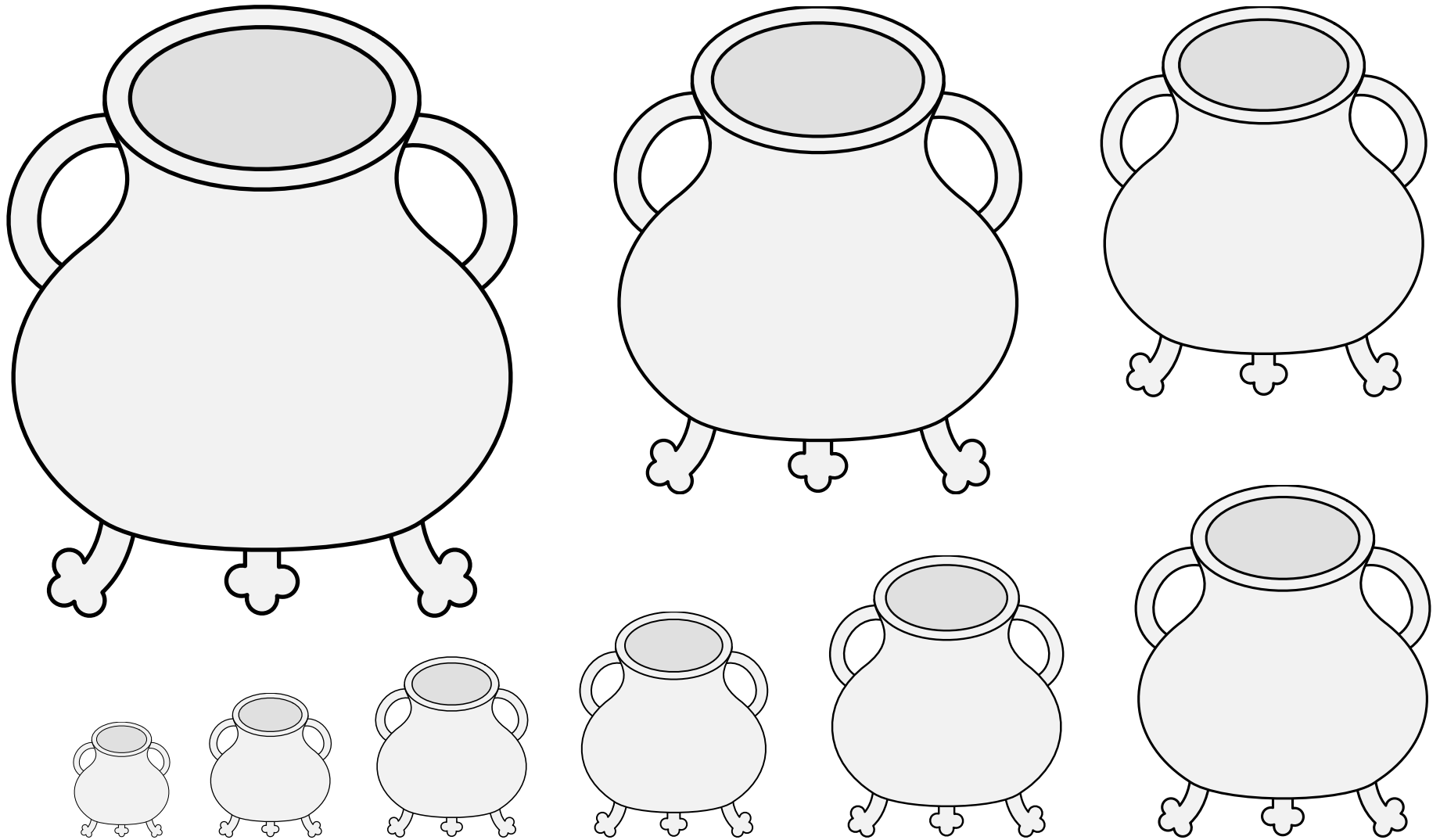

A cooking vessel in which you might boil up a stew.
Default orientation: opening to chief. No proper coloration.
Source: BnF MS Allemand 304. Artist unknown. (Folio 319r.)

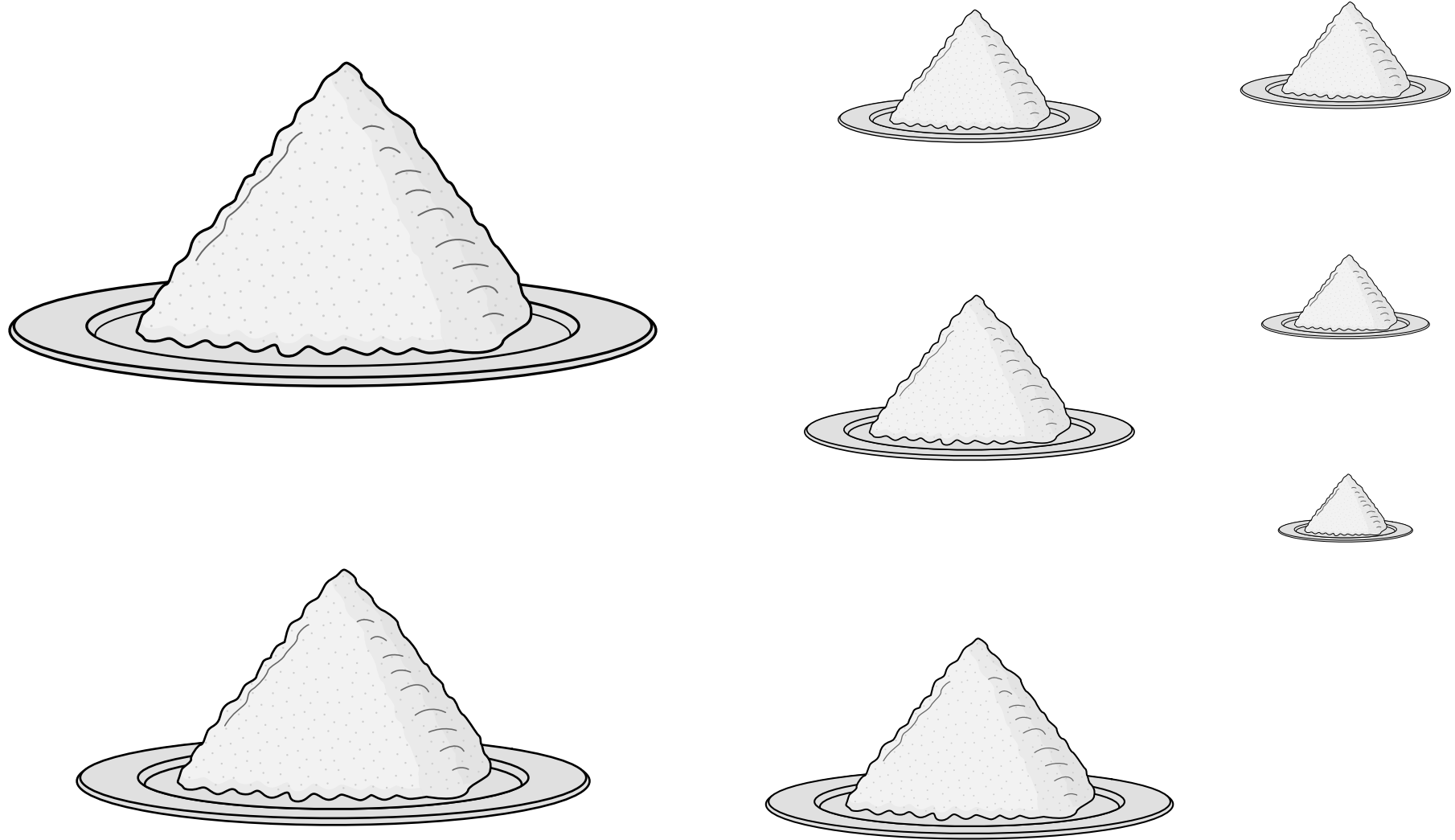

A heap of tiny grains as you might find in a kitchen.

Default orientation: peak to chief. No proper coloration.

Source: Insegne di Vari Principi et Case Illustri d'Italia.

Artist: Giacomo Fontana. (Folio 112r, arms of Farini.)

Flour, Pile of 14.77

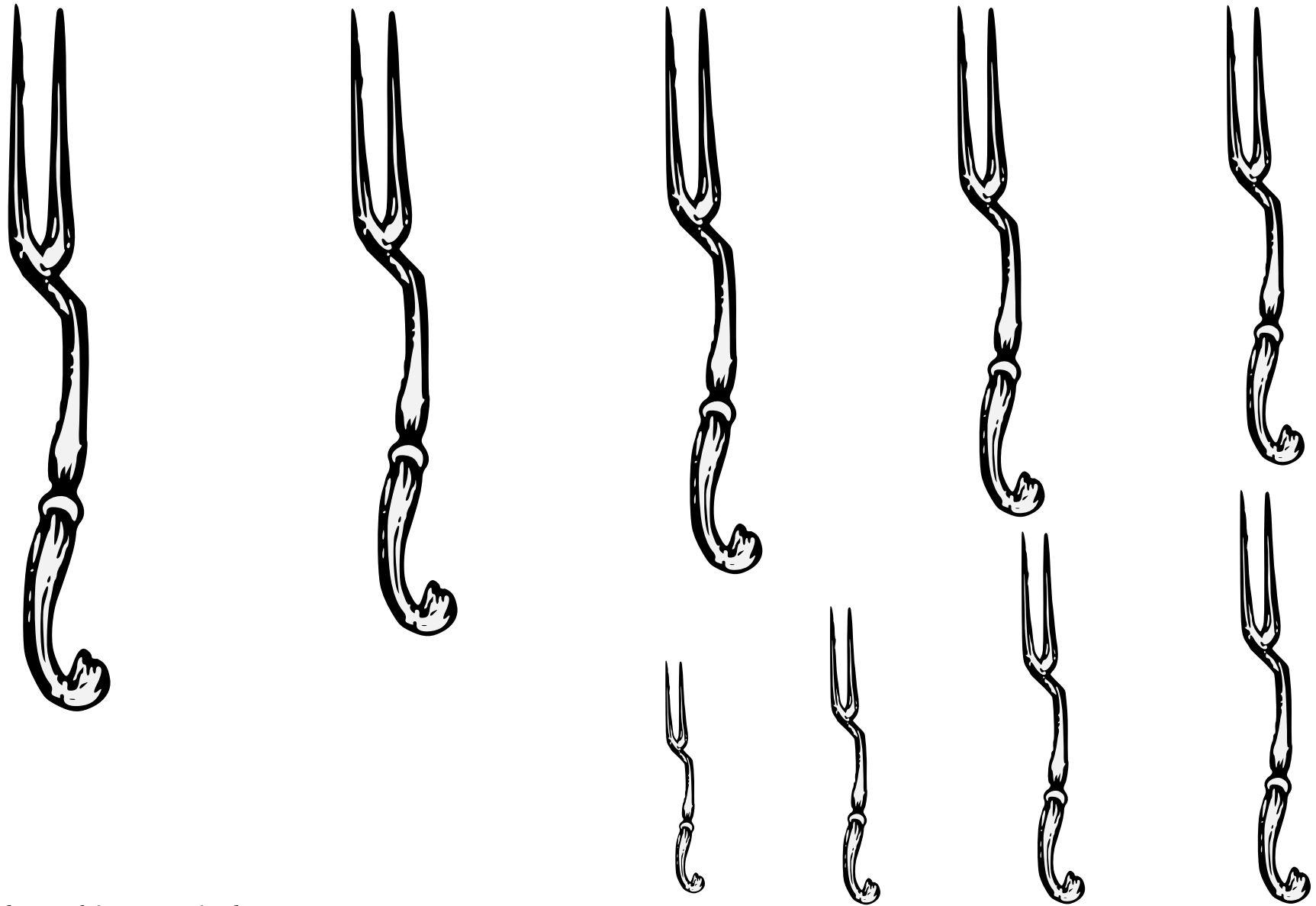

A pronged utensil for eating food.

Default orientation: palewise, handle to base. No proper coloration.

(This may be the earliest image of a table fork printed in Europe.)

Source: Opera Dell'arte Del Cucinare. Artist unknown. (Page 966.)

Fork (1) 14.78

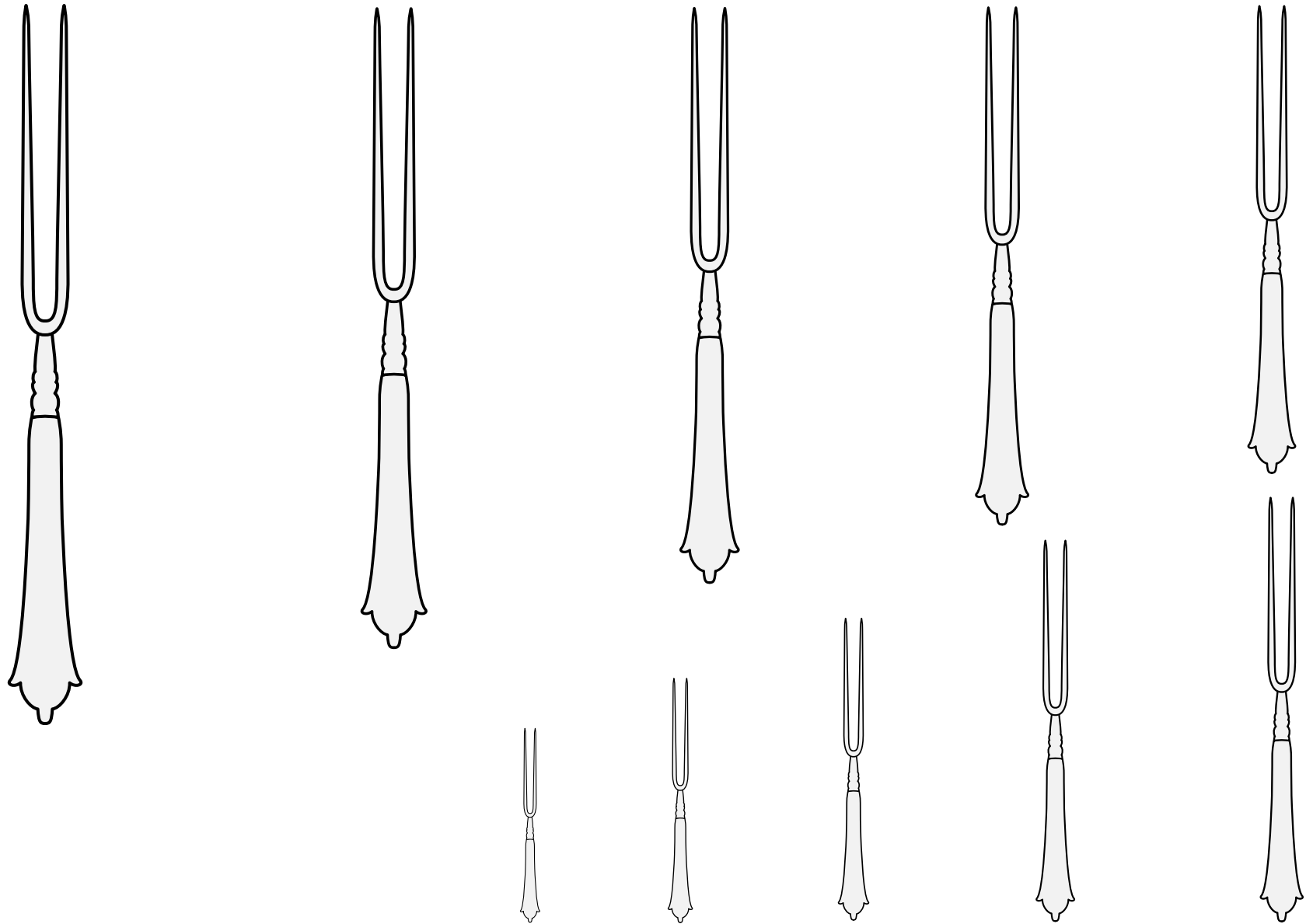

A pronged utensil for eating food.

Default orientation: palewise, handle to base. No proper coloration.

Source: Victoria and Albert Museum. (Adapted from an image of a sixteenth-century French fork.)

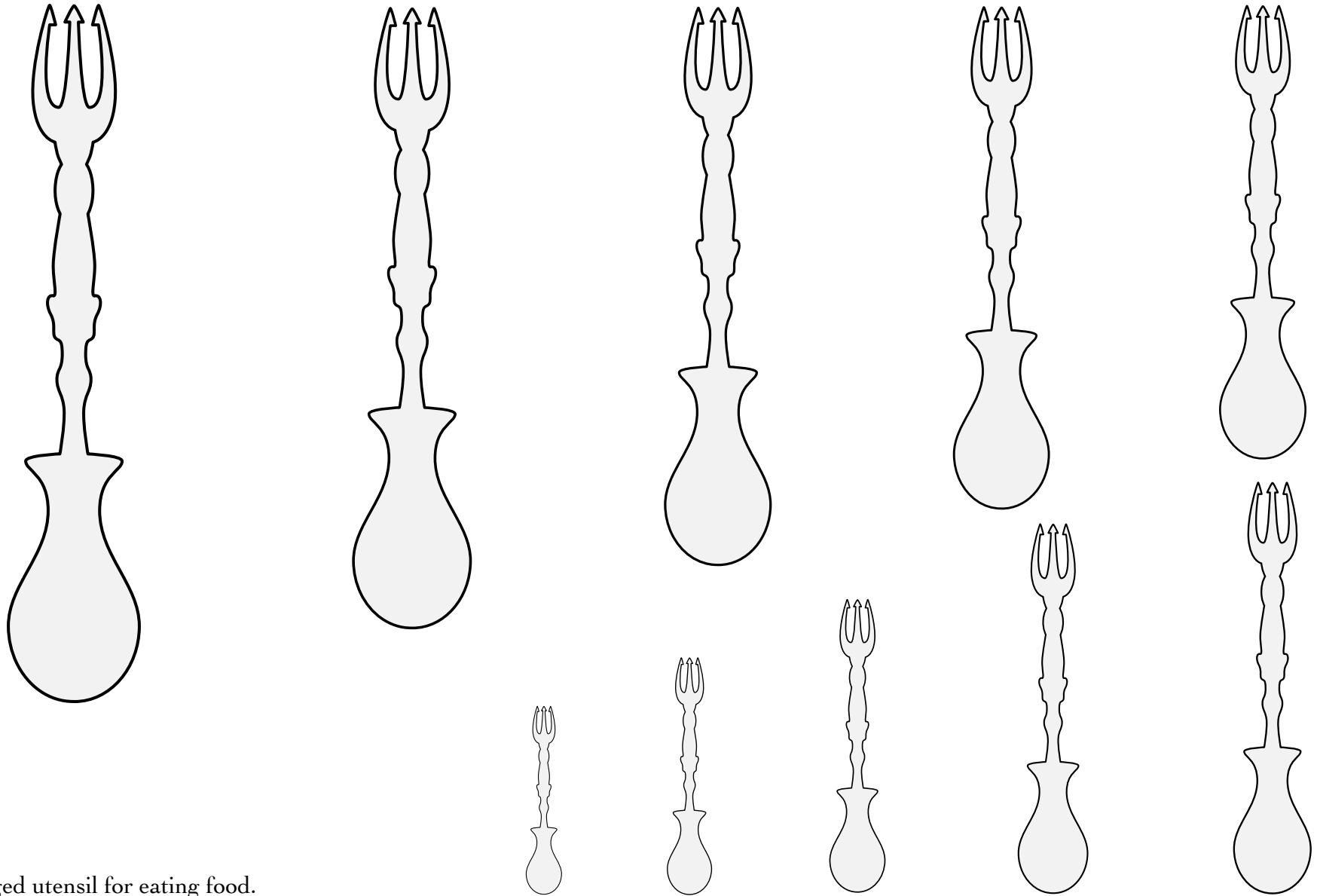

A pronged utensil for eating food.

Default orientation: palewise, handle to base.

No proper coloration.

Source: Met Museum. (Adapted from a third-century Roman serving utensil, accession number: 2006.514.3.)

Fork Terminating in a Spoon 14.80

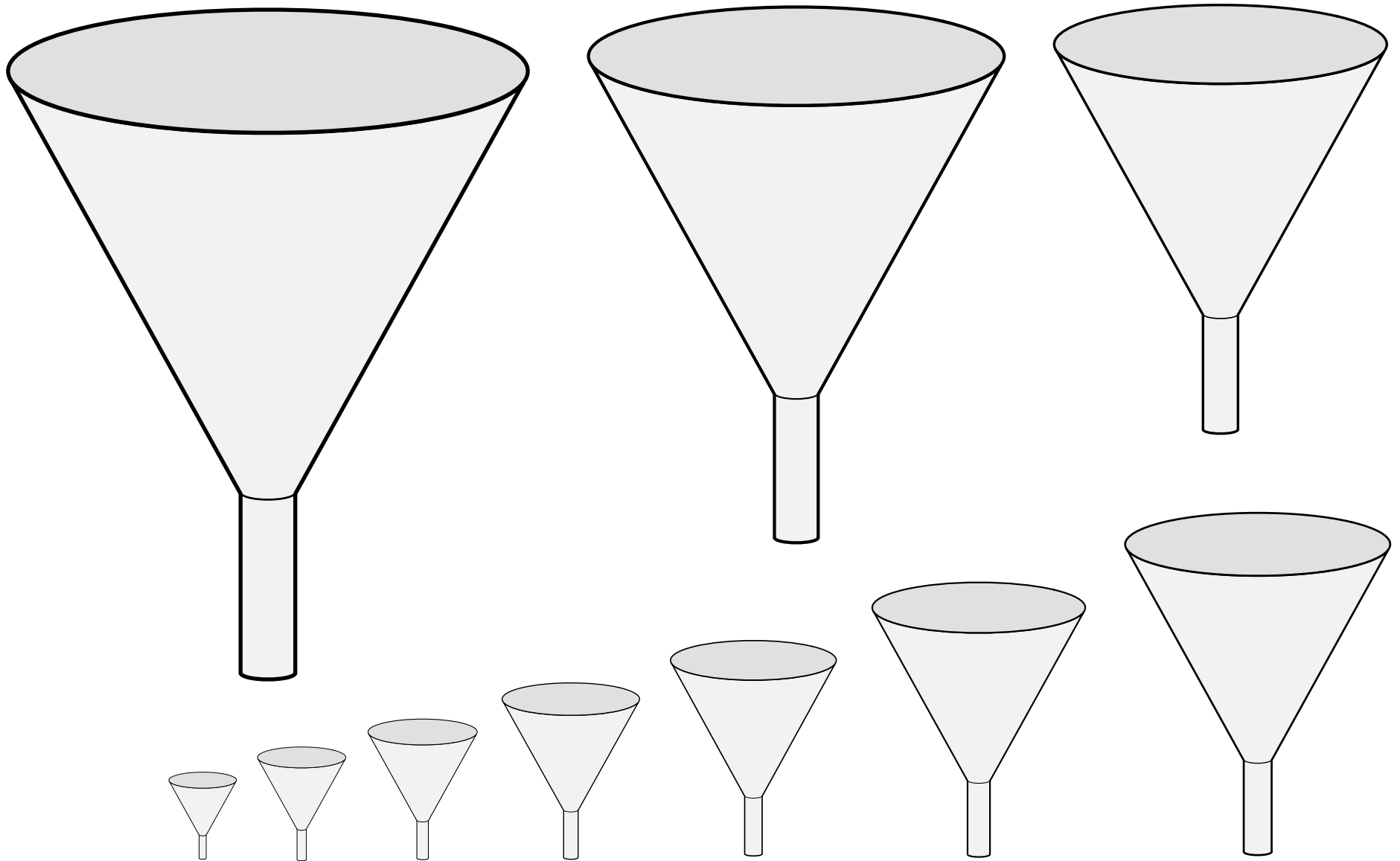

A tool for pouring large amounts of liquid through a small hole.

Default orientation: upright, spout to base. No proper coloration.

Adapted from a depiction in a 1505 painting by Hieronymus Bosch titled "the Temptation of Saint Anthony".

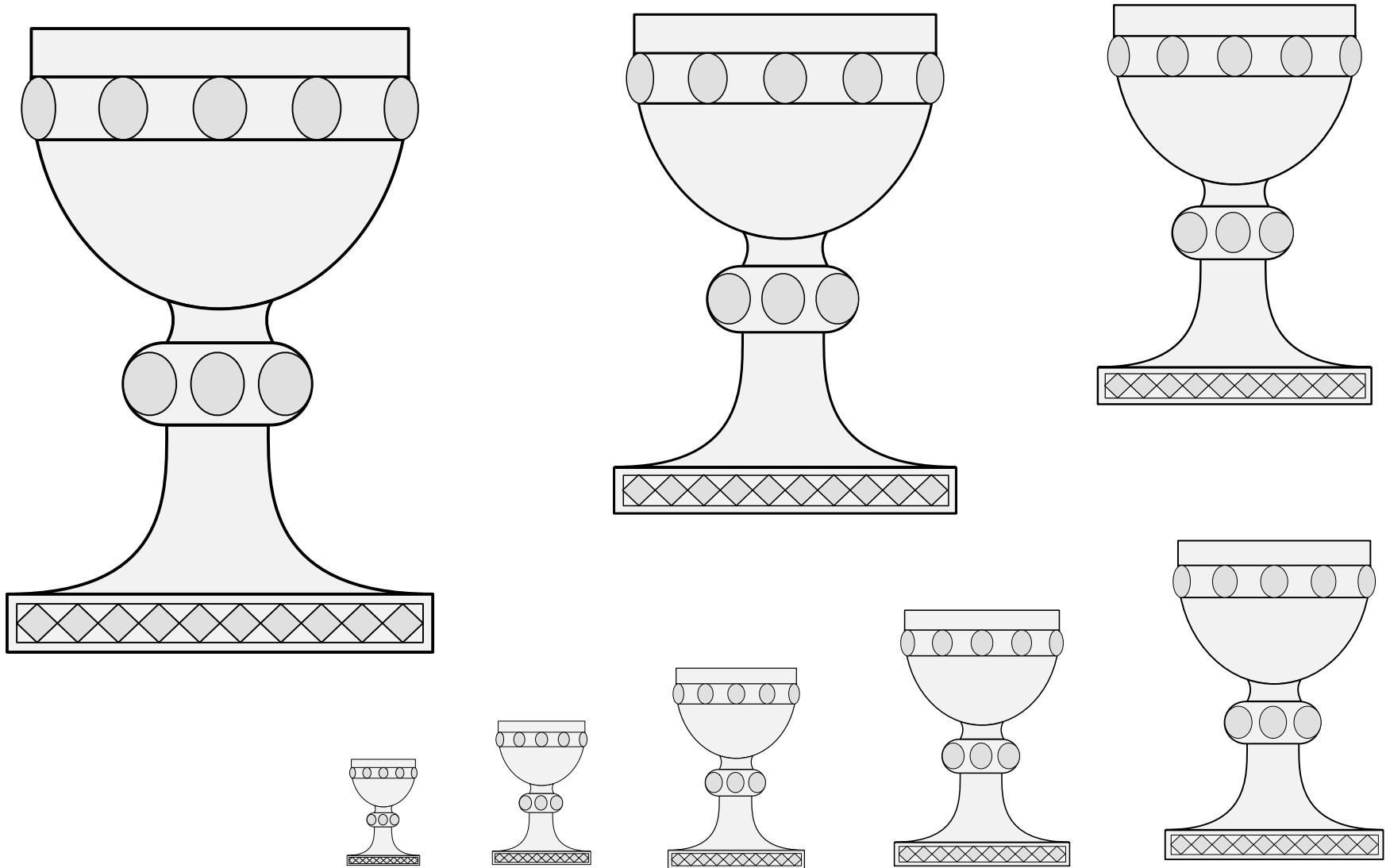

A fancy cup.

Default orientation: upright. No proper coloration.

Adapted from inset tile at the Cathedral of Saint John the Divine.

Goblet, Jeweled 14.82

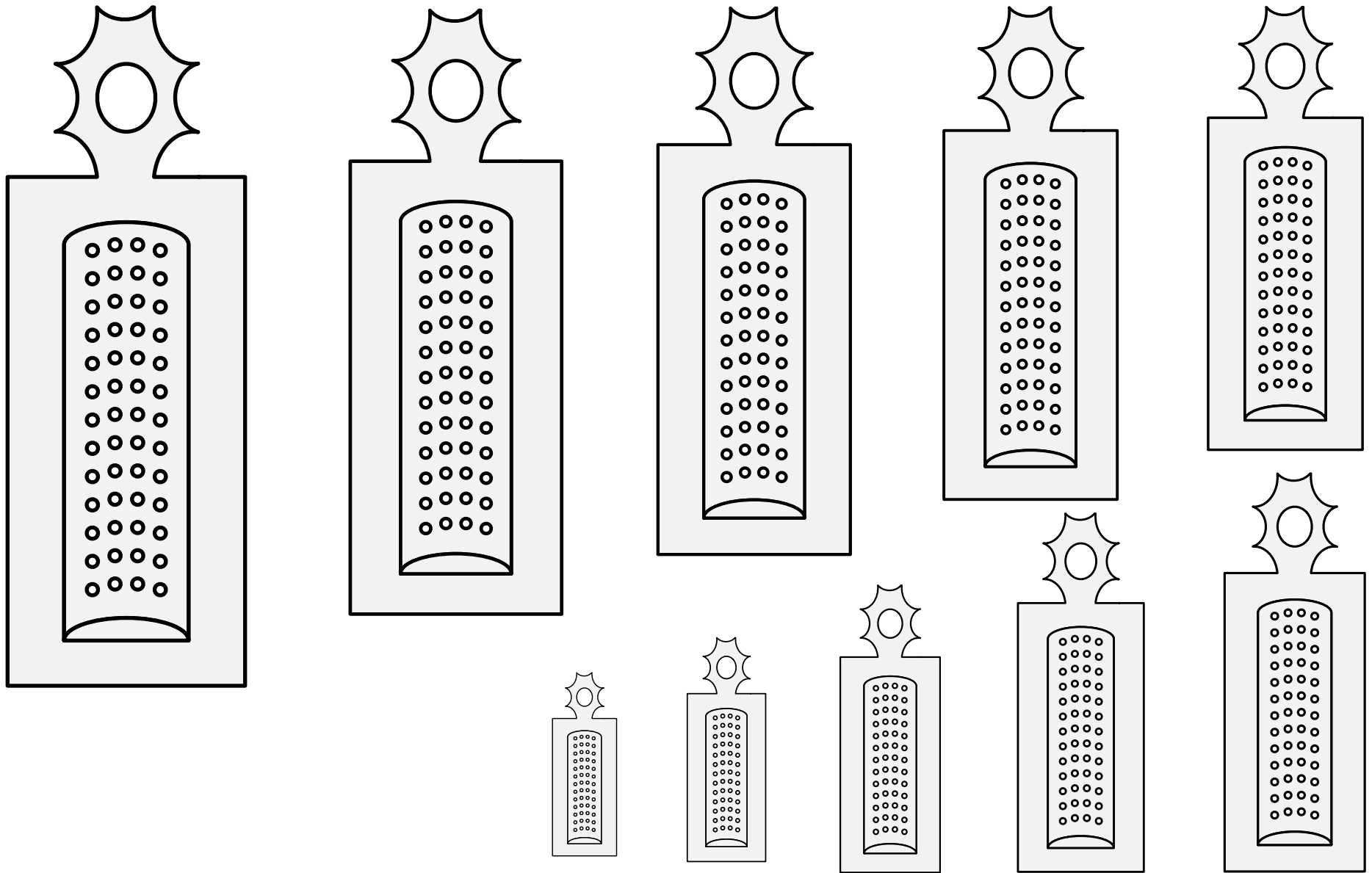

A metal tool with many sharp holes, used for grating or shredding ingredients.

Default orientation: Palewise. No proper coloration.

Source: Neustifter Wappenbuch. Artist: Vigil Raber. (From the arms of Ribeilen.)

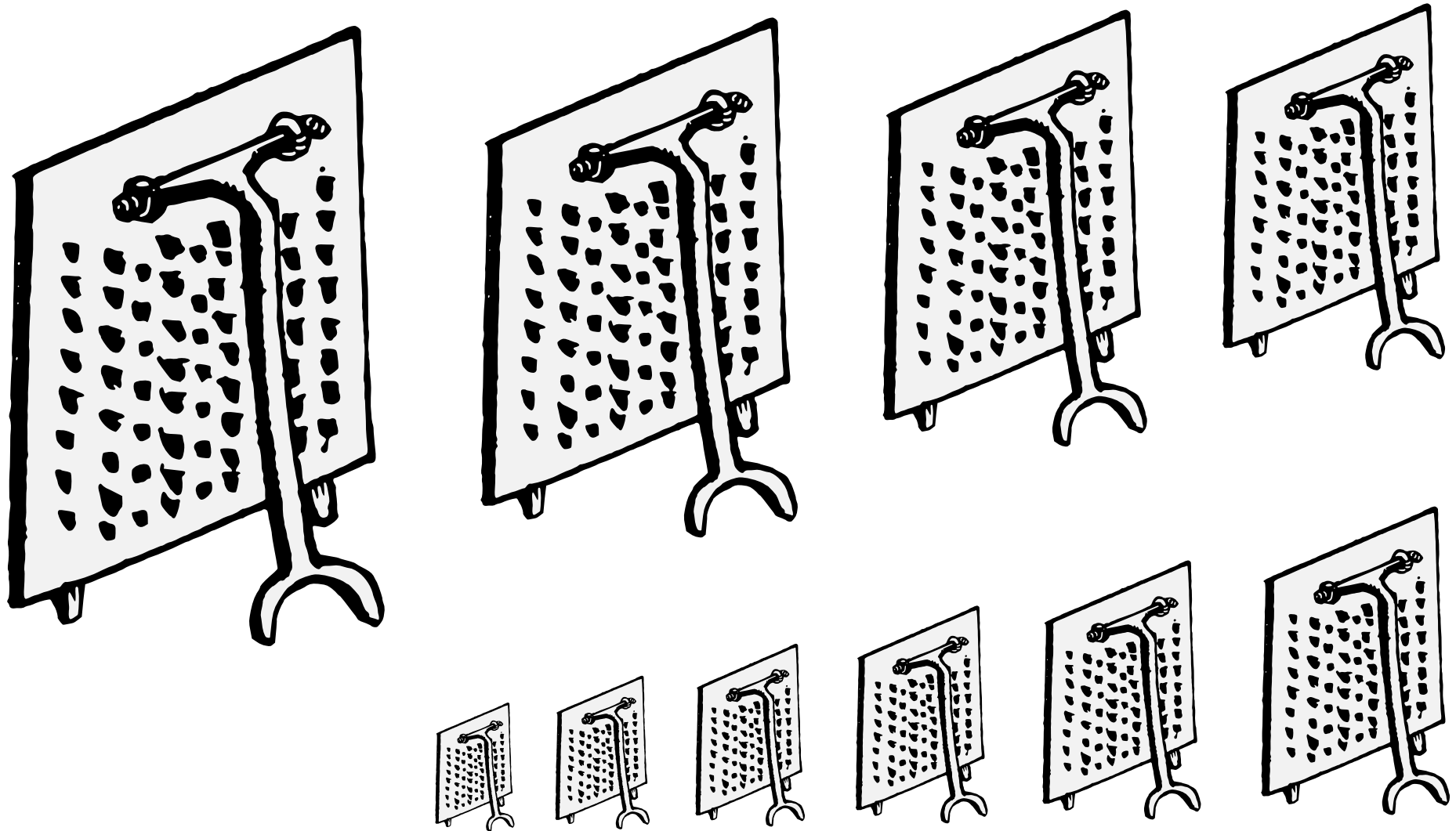

A metal tool with many sharp holes, used for grating or shredding ingredients.

Default orientation: Palewise. No proper coloration.

Source: Opera Dell'arte Del Cucinare. Artist unknown. (Page 940.)

Grater, Cheese (1) 14.84

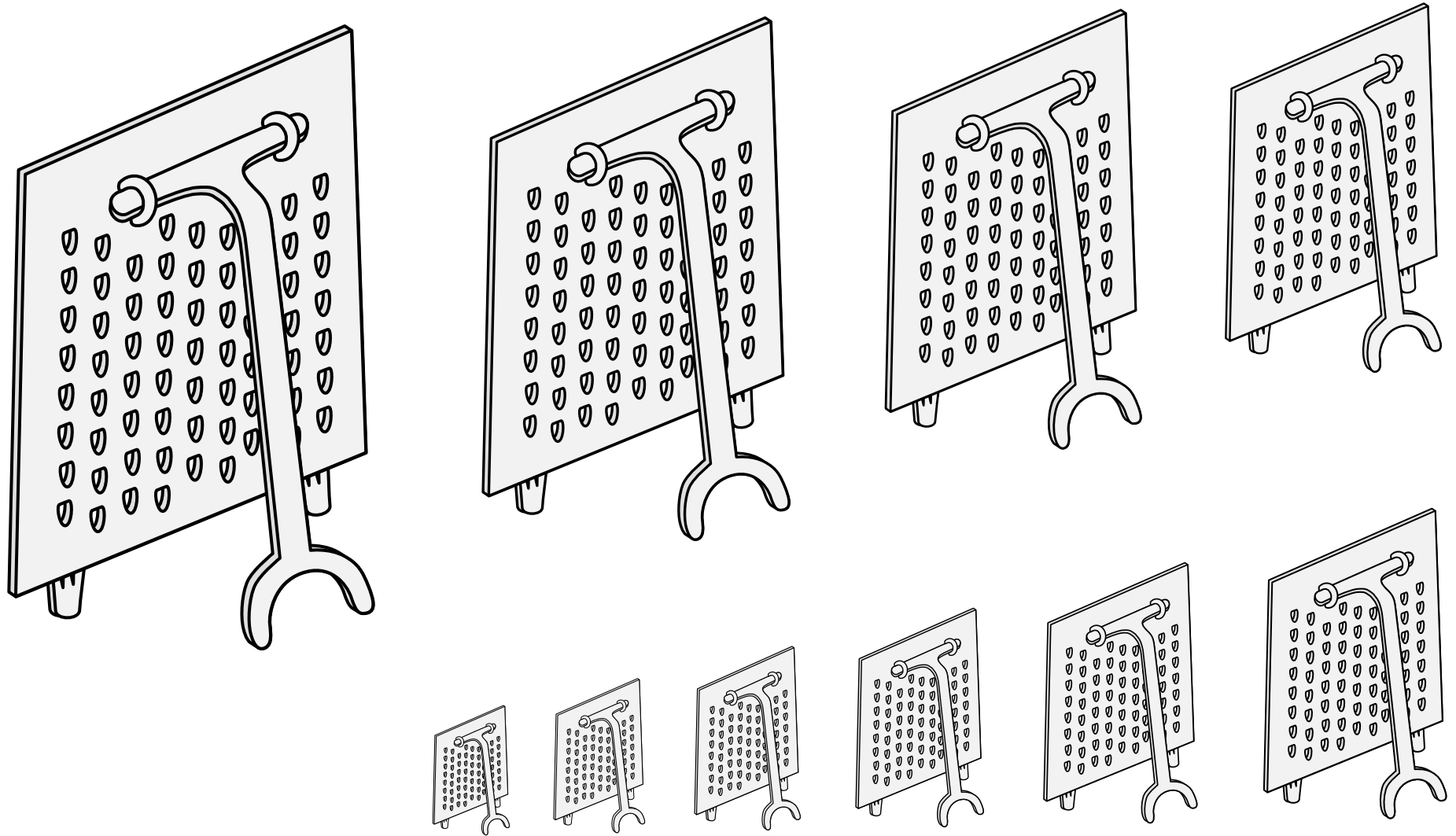

A metal tool with many sharp holes, used for grating or shredding ingredients.

Default orientation: Palewise. No proper coloration.

Source: Opera Dell'arte Del Cucinare. Artist unknown. (Page 940.)

Grater, Cheese (2) 14.85

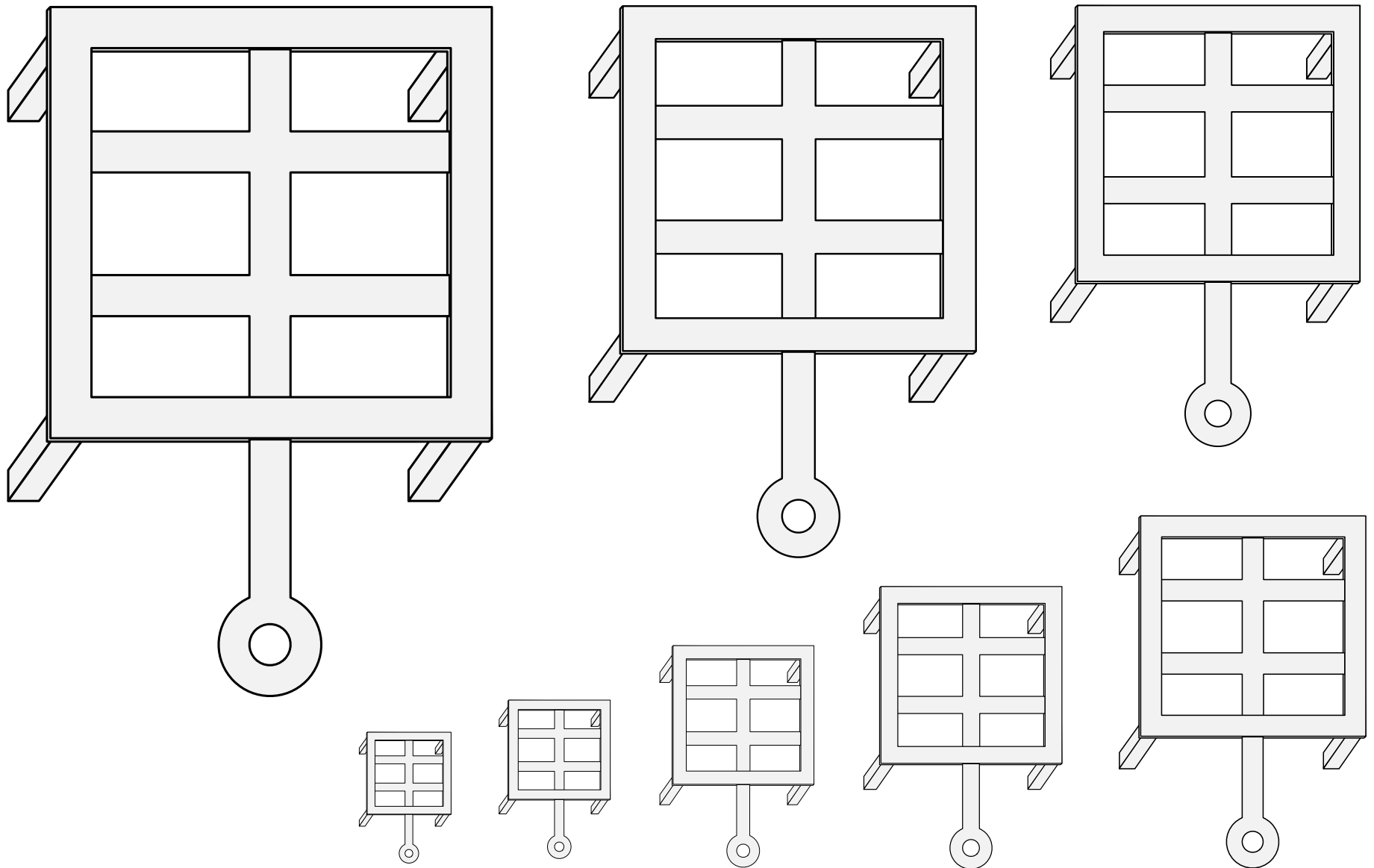

A metal support used for cooking food, like a barbecue grill.

Default orientation: handle to base. No proper coloration.

Source: Heiligen Römischen Reiches. Artist unknown. (Page 830.)

Gridiron (1) 14.86

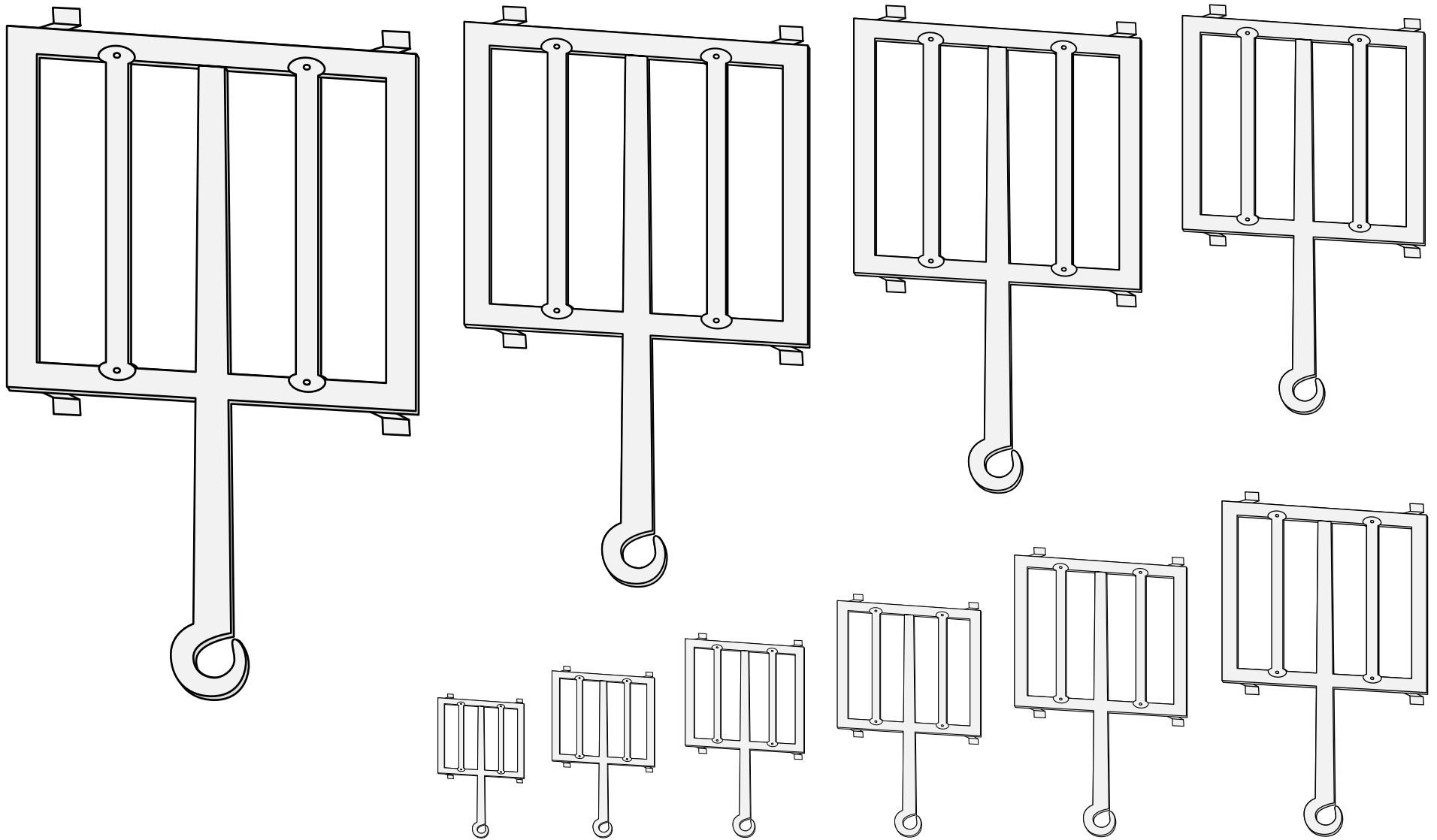

A metal support used for cooking food, like a barbecue grill.

Default orientation: handle to base. No proper coloration.

Source: Opera Dell'arte Del Cucinare. Artist unknown. (Page 966.)

Adapted by Mathghamhain Ua Ruadháin.

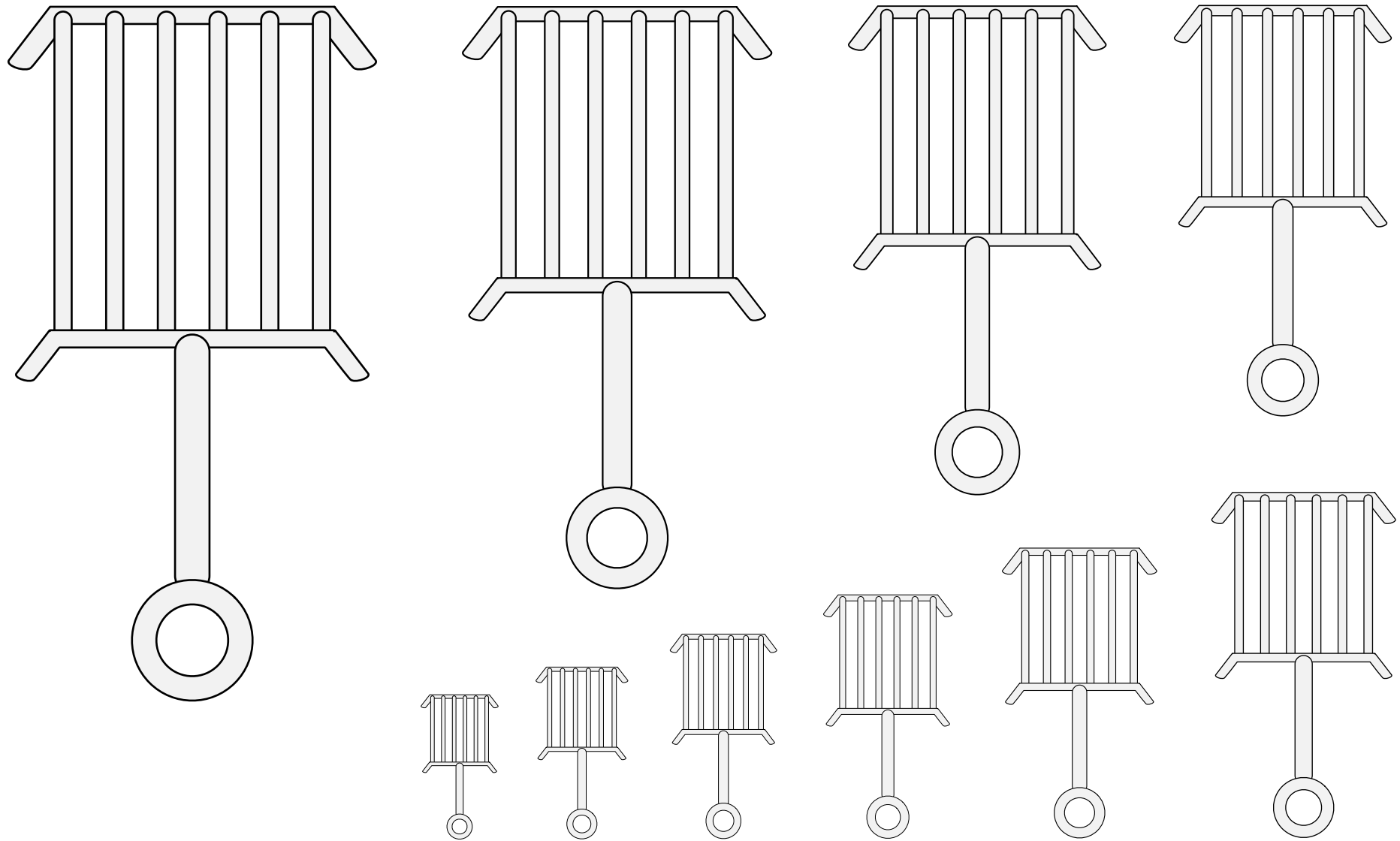

A metal support used for cooking food, like a barbecue grill.

Default orientation: handle to base. No proper coloration.

Source: Armorial Bearings of the Trading Companies and Lord Mayors of London. Artist unknown. (Page 49.)

Gridiron (3) 14.88

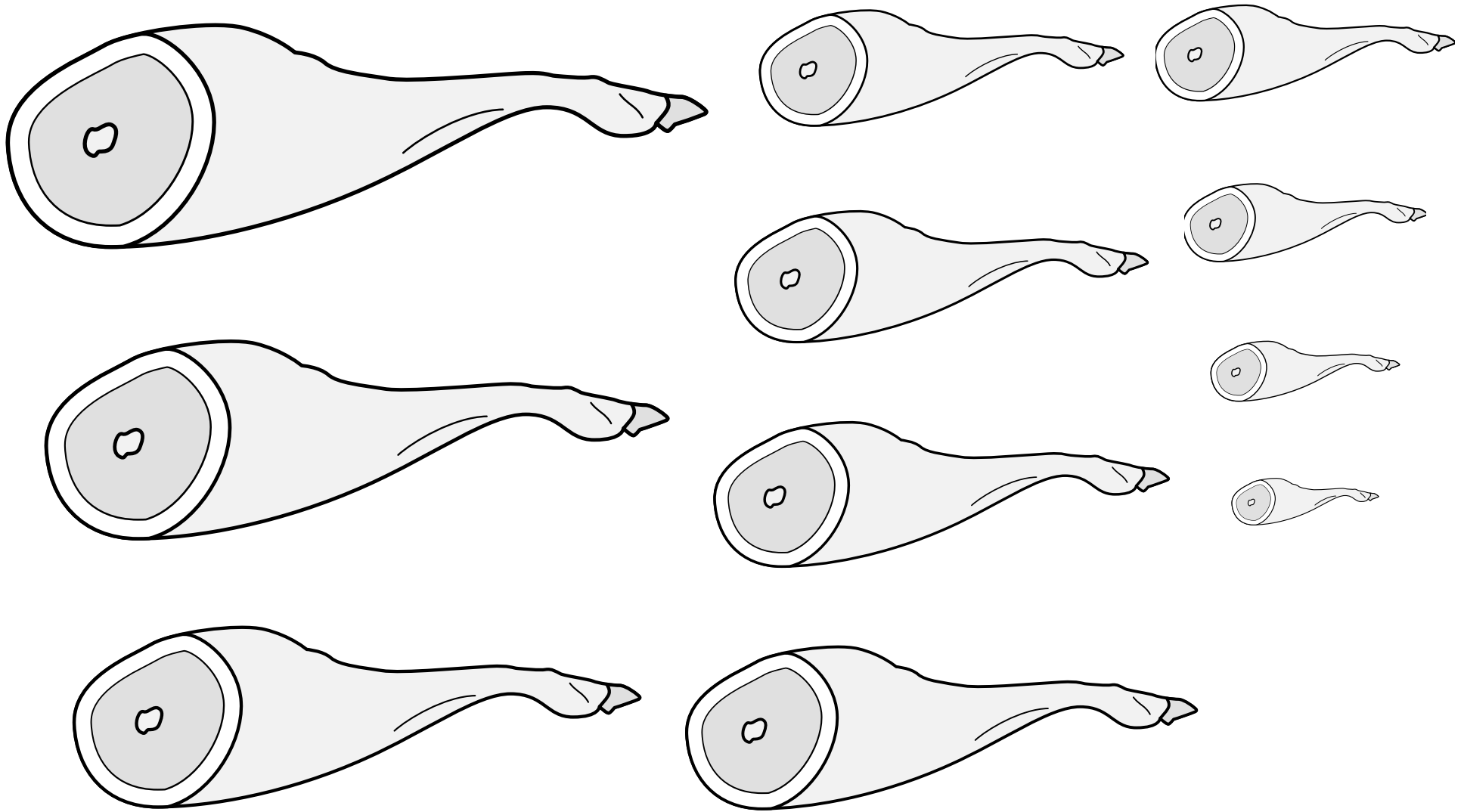

A cooked pig's leg.
Default orientation: meaty end to dexter, foot to sinister.

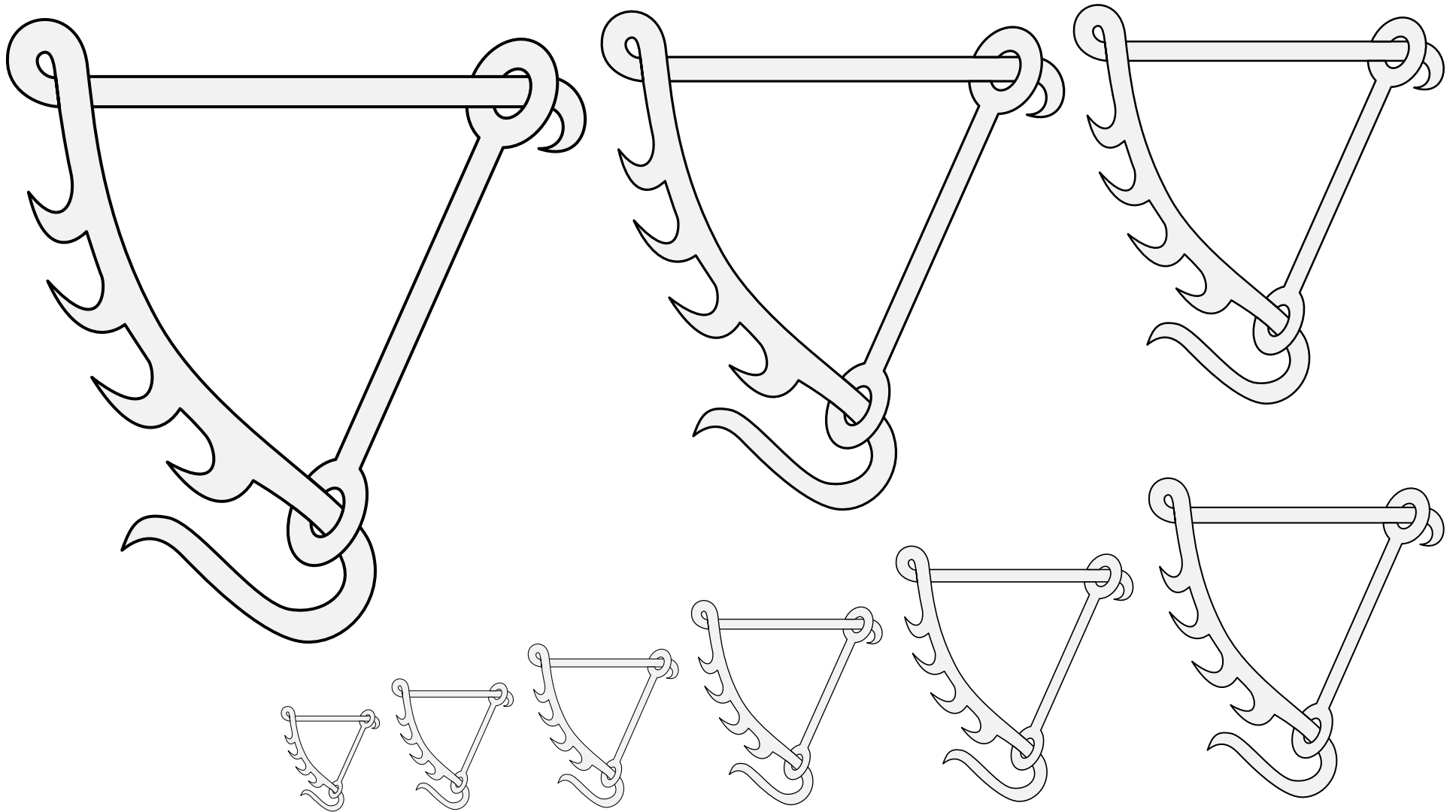

An adjustable hook for controlling the position of cooking pots above a fire.

Default orientation: triangular, point to base. Proper coloration: black iron.

Source: Baltisches Wappenbuch. Artist: Adolph M. Hildebrandt.
(Page 51, arms of Ketteler.)

Hook, Kettle • 14.90

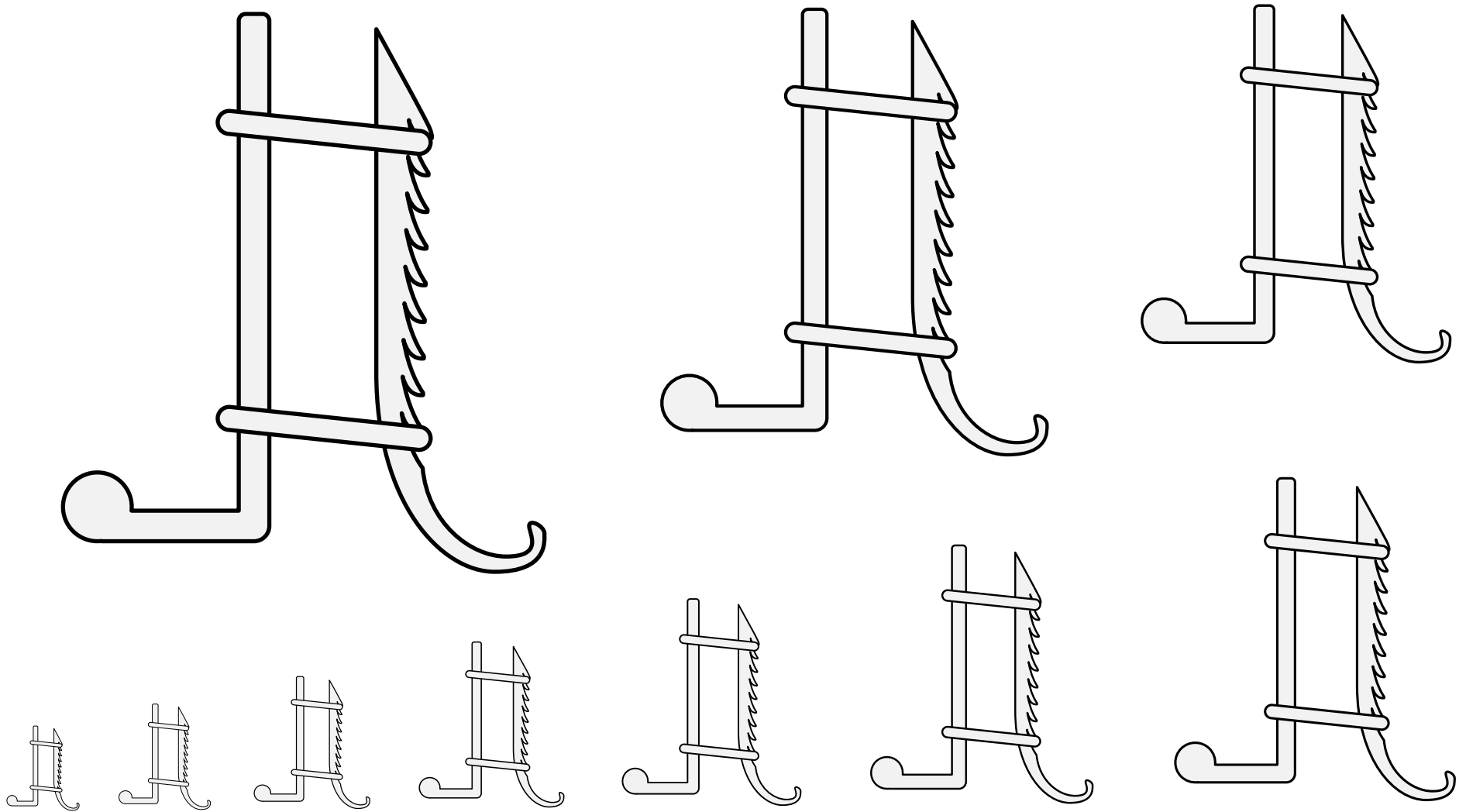

An adjustable hook for controlling the position of cooking pots above a fire.

Default orientation: palewise. Proper coloration: black iron.

Source: Siebmacher's Wappenbuch of 1605.

Artist: Johann Siebmacher. (Arms of van der Tecke, folio 181.)

Hook, Trammel (1) 14.91

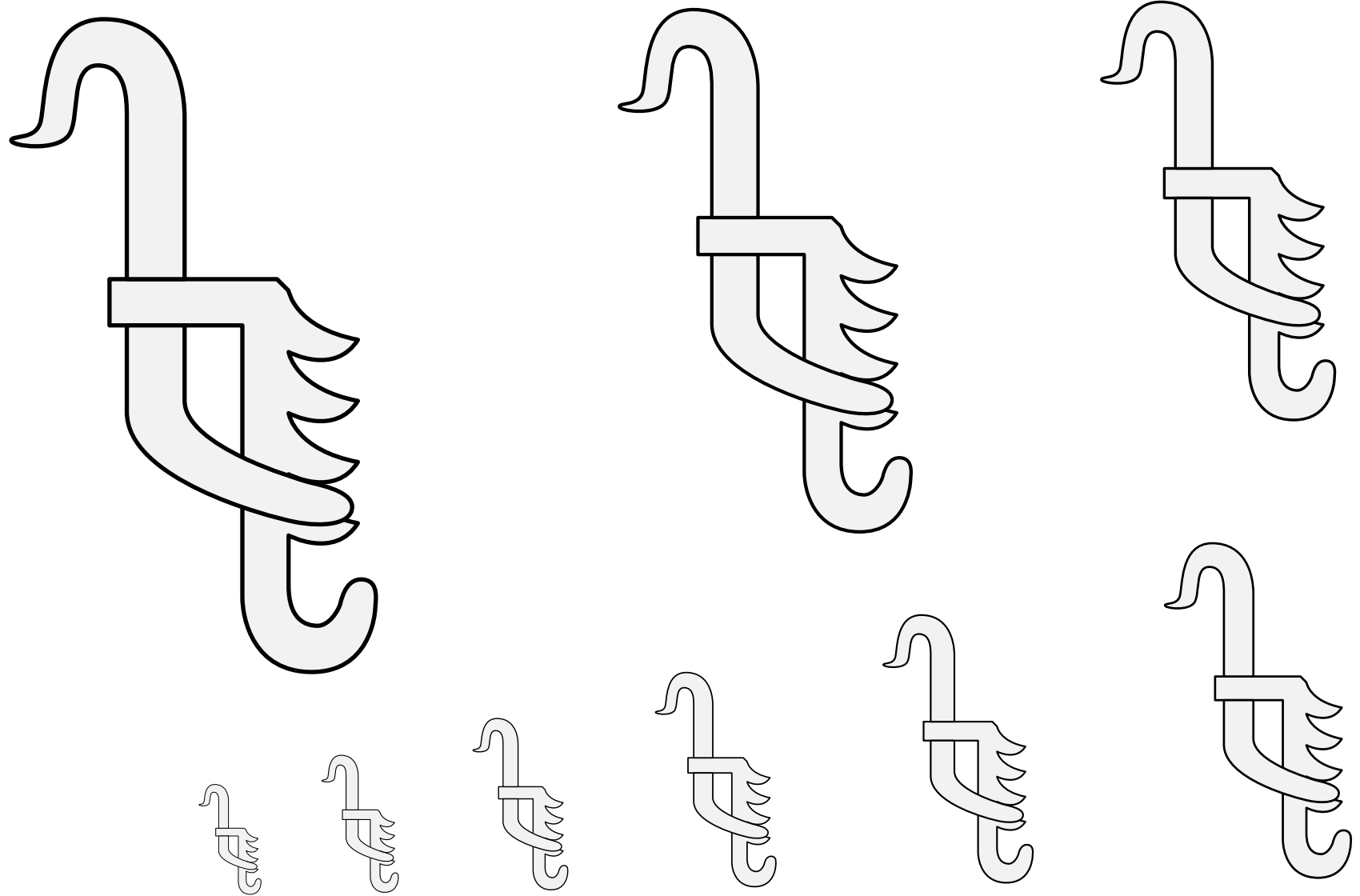

An adjustable hook for controlling the position of cooking pots above a fire.

Default orientation: palewise. Proper coloration: black iron.

Source: BSB Cgm 8030. Artist unknown. (Folio 95v.)

Hook, Grammel (2) 14.92

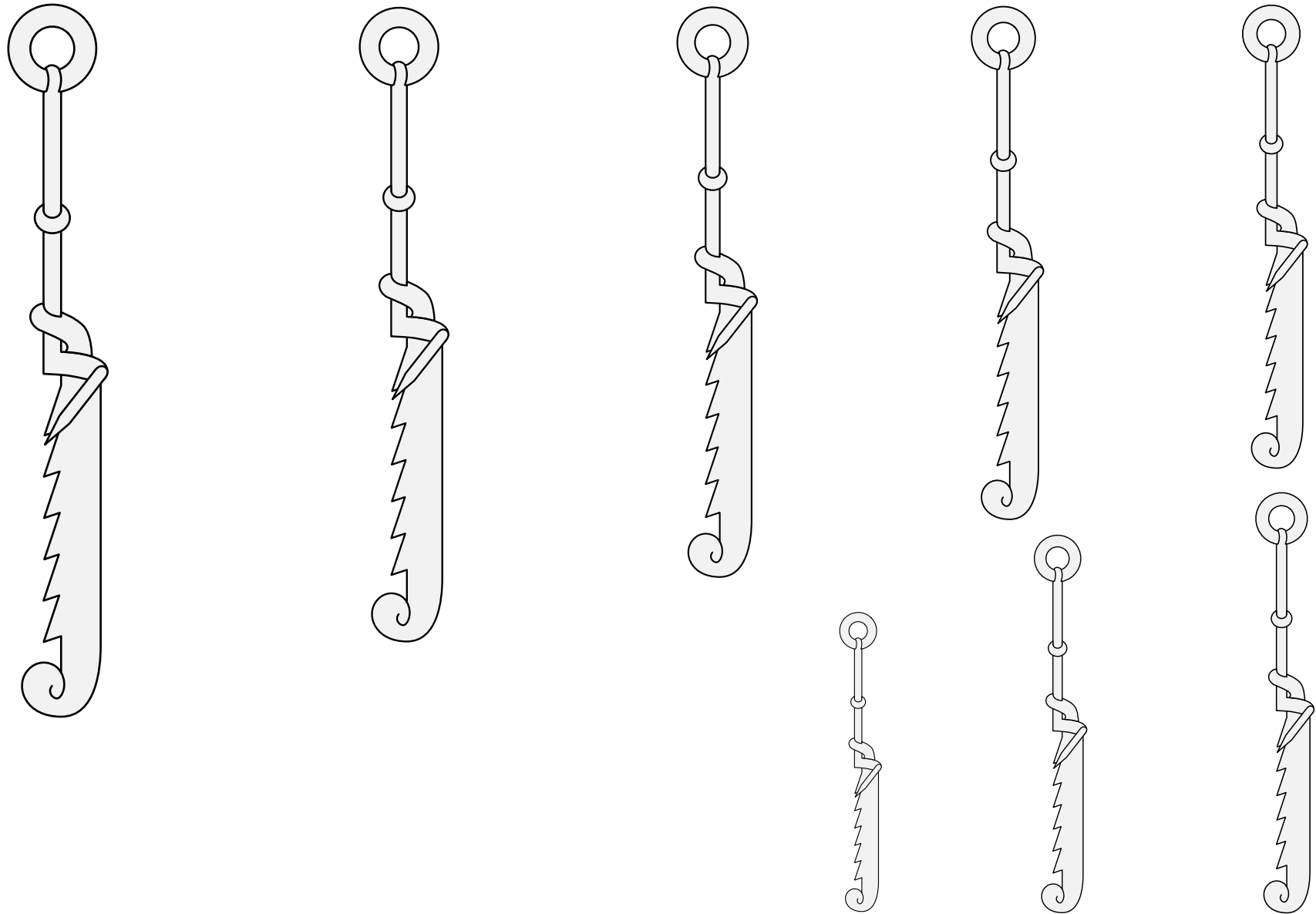

An adjustable hook for controlling the position of cooking pots above a fire.

Default orientation: palewise. Proper coloration: black iron.

Source: Le second volume de la premiere partye du blason d'armoiries. Artist unknown. (Folio 131r.)

Hook, Trammel (3) 14.93

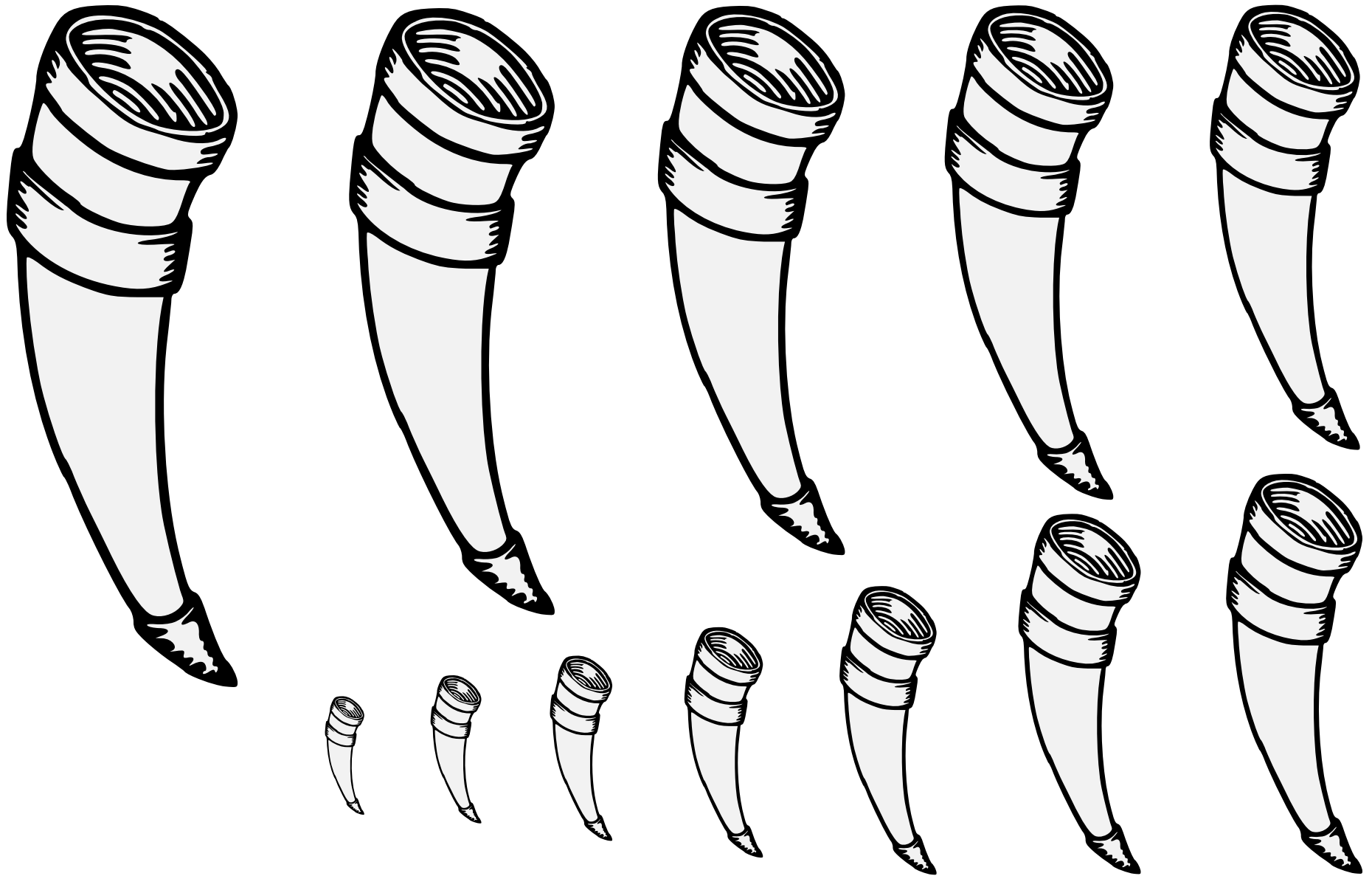

An animal's horn, adapted to hold a beverage.

Default orientation: curving to dexter, opening to chief. No proper coloration.

Source: Pennsic Traceable Art. Artist: Tristran Deans (attributed).

Horn, Drinking (1) 14.94

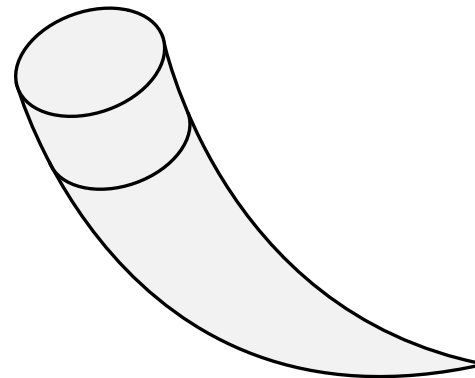
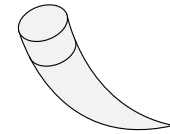
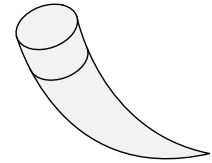
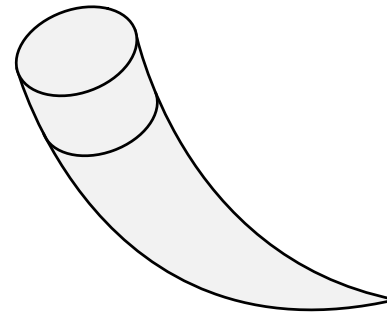
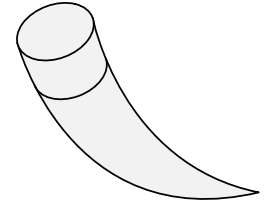
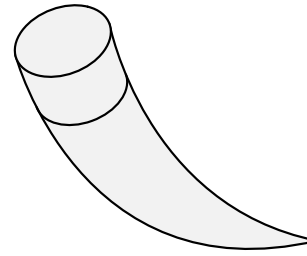
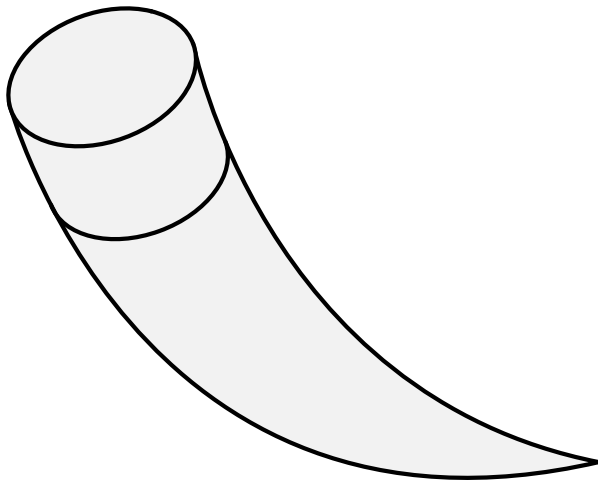
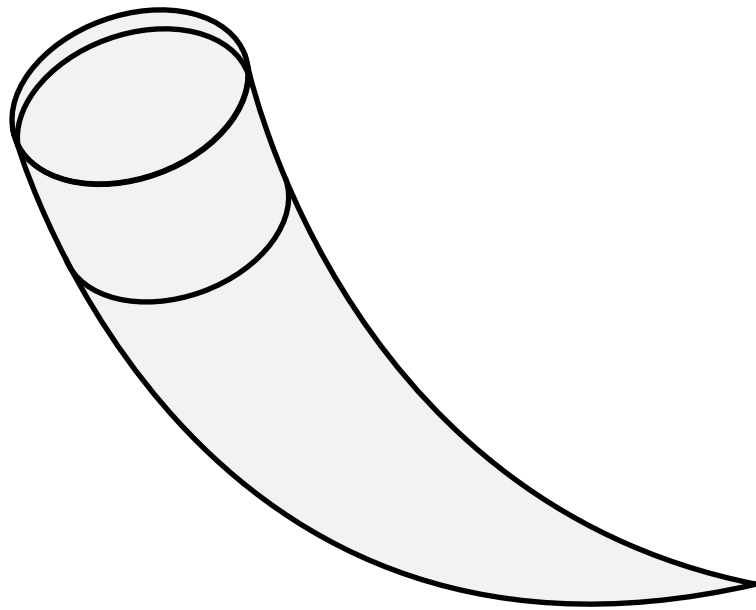

An animal's horn, adapted to hold a beverage.

Default orientation: curving to dexter, opening to chief. No proper coloration.

Source: Mamluk Emblems Online Corpus. Artist unknown.

(Adapted from a photograph of a lunchbox dated to before 1489, depicting the emblem of Amir Zayn al-dīn Khushqadam.)

Horn, Drinking (2) 14.95

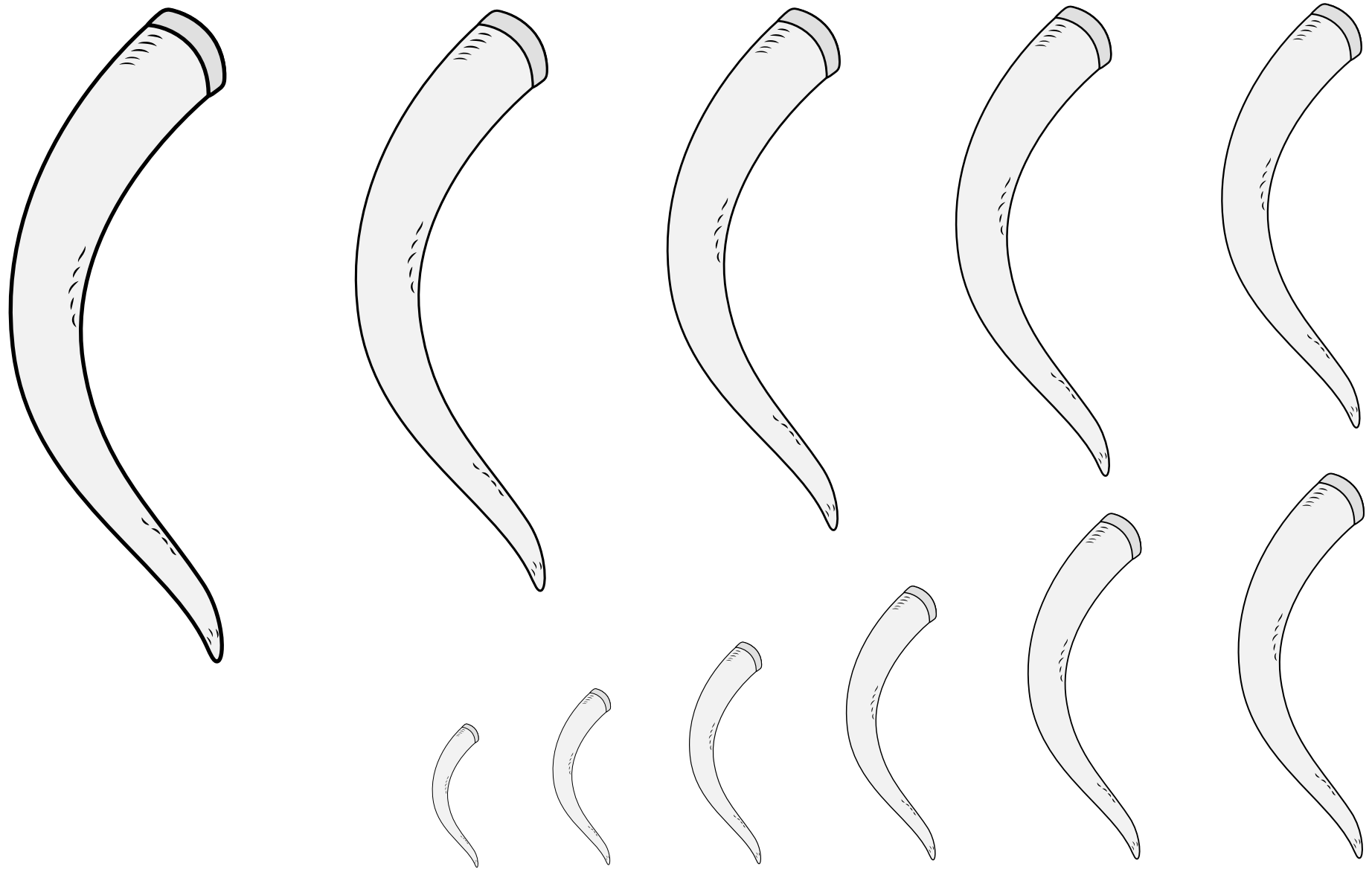

An animal's horn, adapted to hold a beverage.

Default orientation: curving to dexter, opening to chief. No proper coloration.

Source: WappenWiki. Artist: Joakim Spuller.

Horn, Drinking (3) 14.96

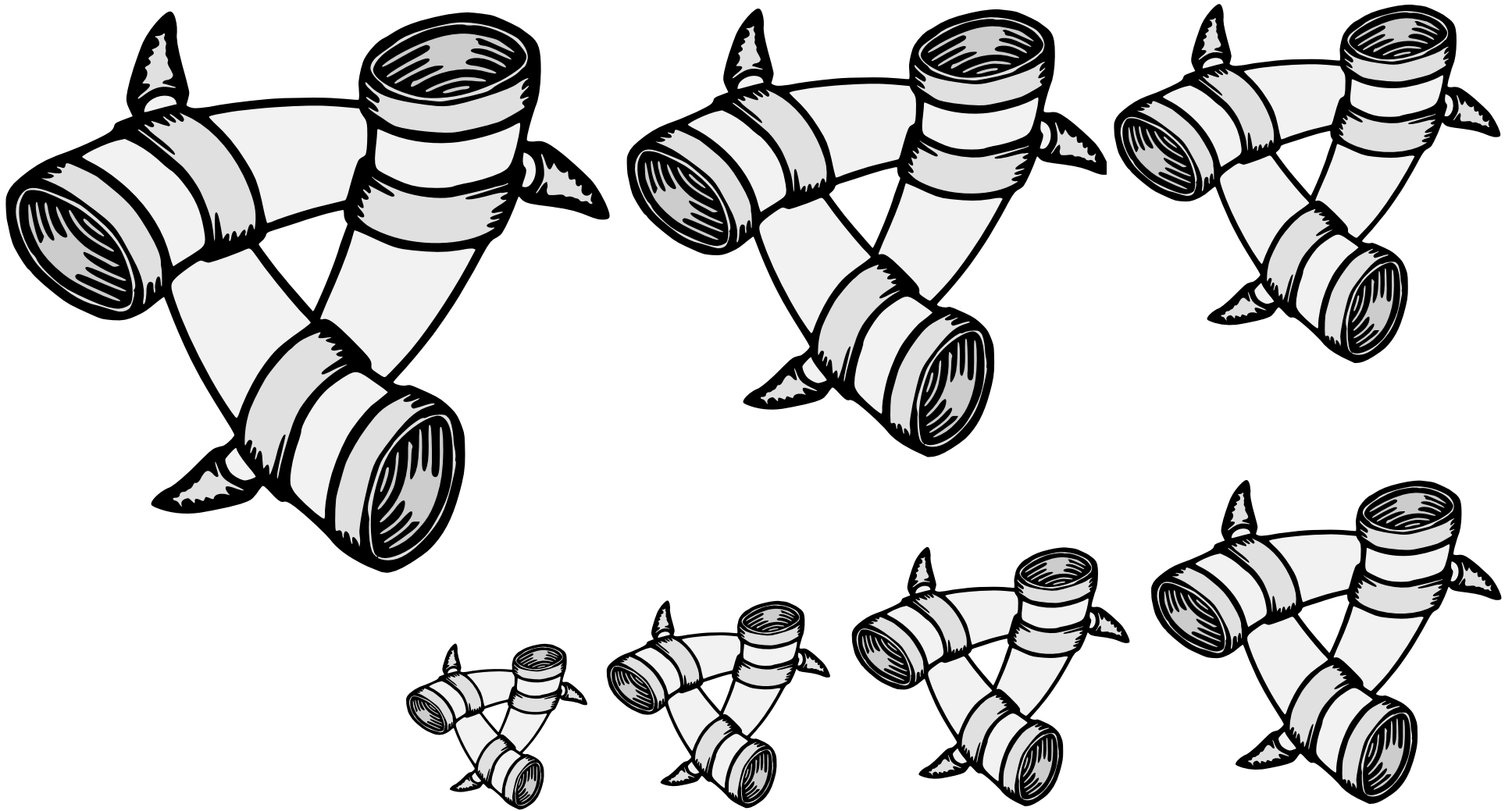

An animal's horn, adapted to hold a beverage.

Default orientation: curving to dexter, opening to chief. No proper coloration.

Source: Pennsic Traceable Art.

Artist: Tristran Deans (attributed).

Adapted by Thora Brandsdottir.

Horns, Three Drinking, Fretted 14.97



A leather mug such as might be used to drink beer.

Default orientation: upright. No proper coloration.

Artist: Mathghamhain Ua Ruadháin. Based on images of a Tudor leather tankard.

Jack 14.98

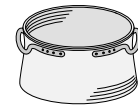
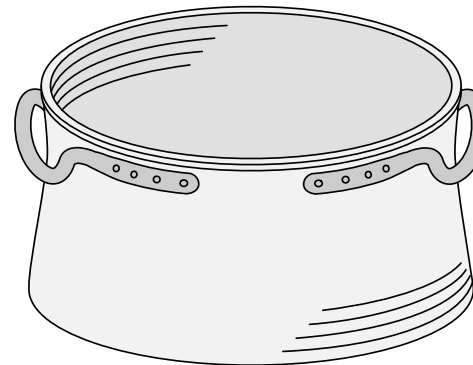
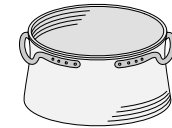
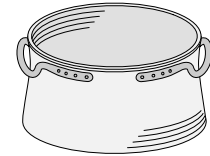
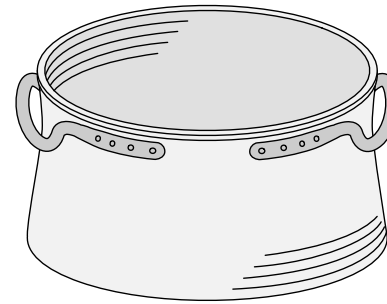
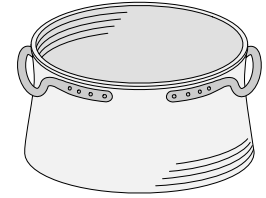
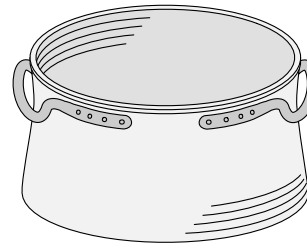
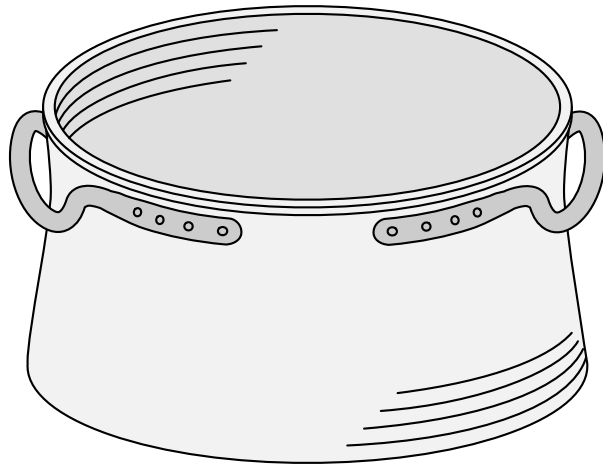
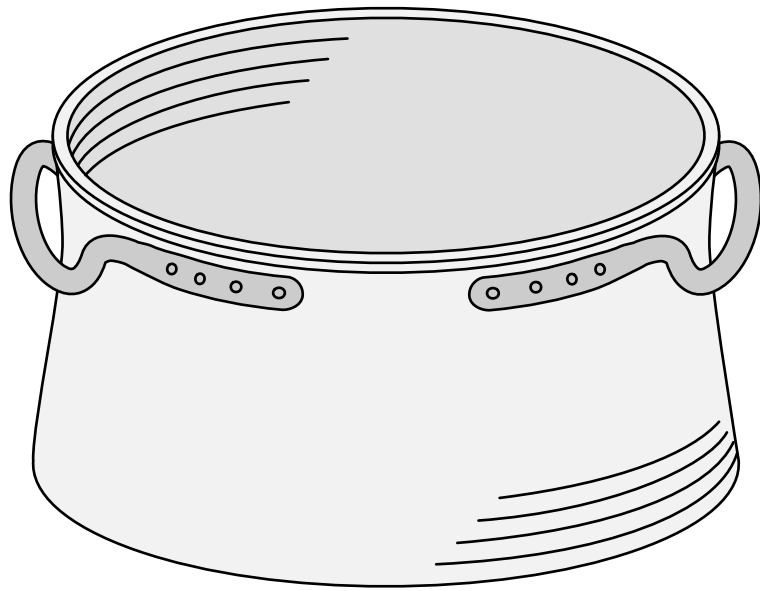

A flat-bottomed cooking pot with mostly-straight sides used for heating liquids.

Default orientation: opening to chief. No proper coloration.

Source: Opera Dell'arte Del Cucinare. Artist unknown. (Plate 9, labeled "Caldaro.")

Kettle 14.99

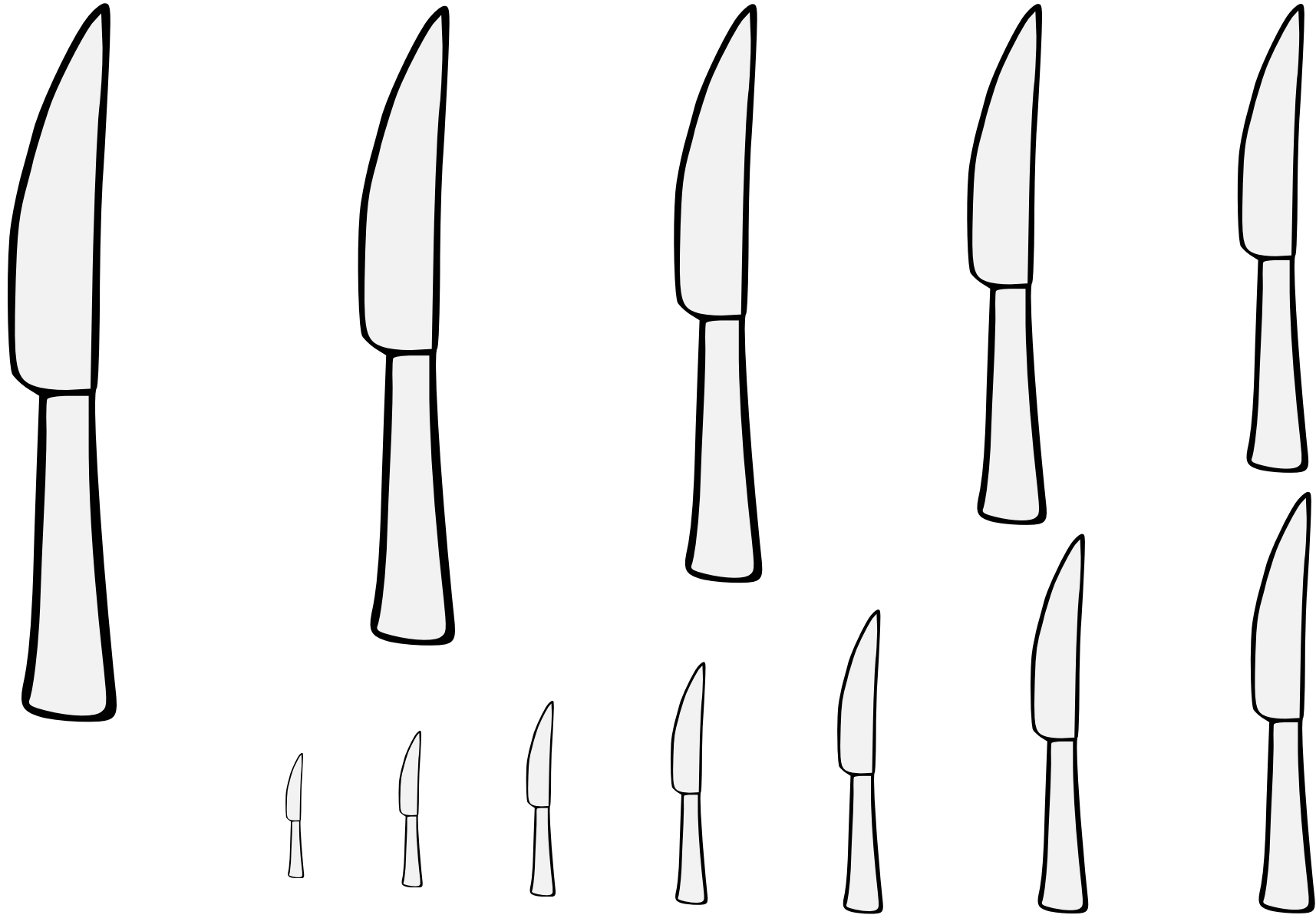

A sharp tool such as one might use in the kitchen.

Default orientation: point to chief, cutting to dexter.

Proper coloration: blade argent, handle Or or brown wood.

Source: Pennsic Traceable Art. Artist unknown.

Knife (1) 14.100

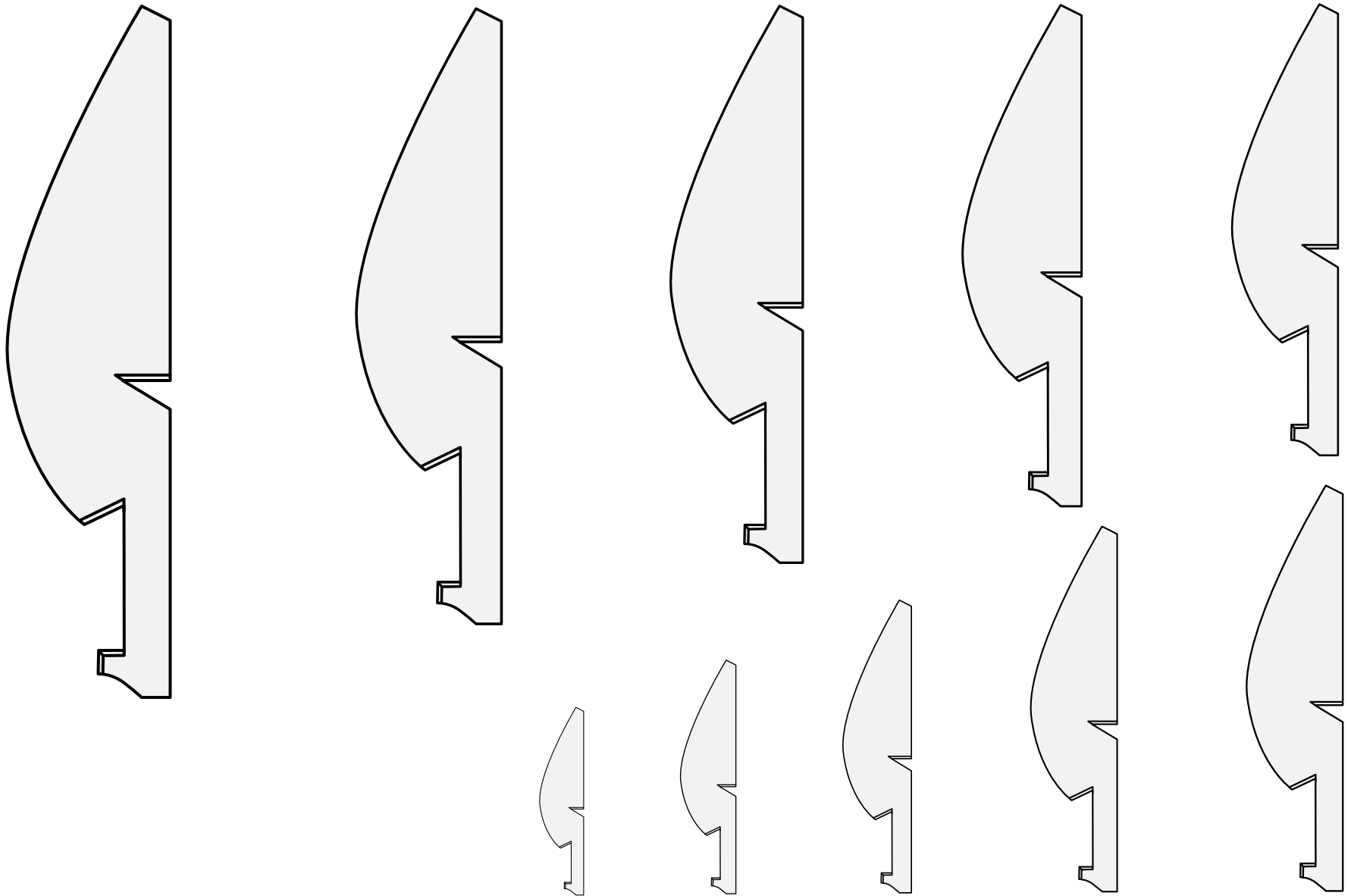

A sharp tool such as one might use in the kitchen.
Default orientation: point to chief, cutting to dexter.
Proper coloration: blade argent, handle Or or brown wood.
Source: Scheibler Armorial. Artist unknown.

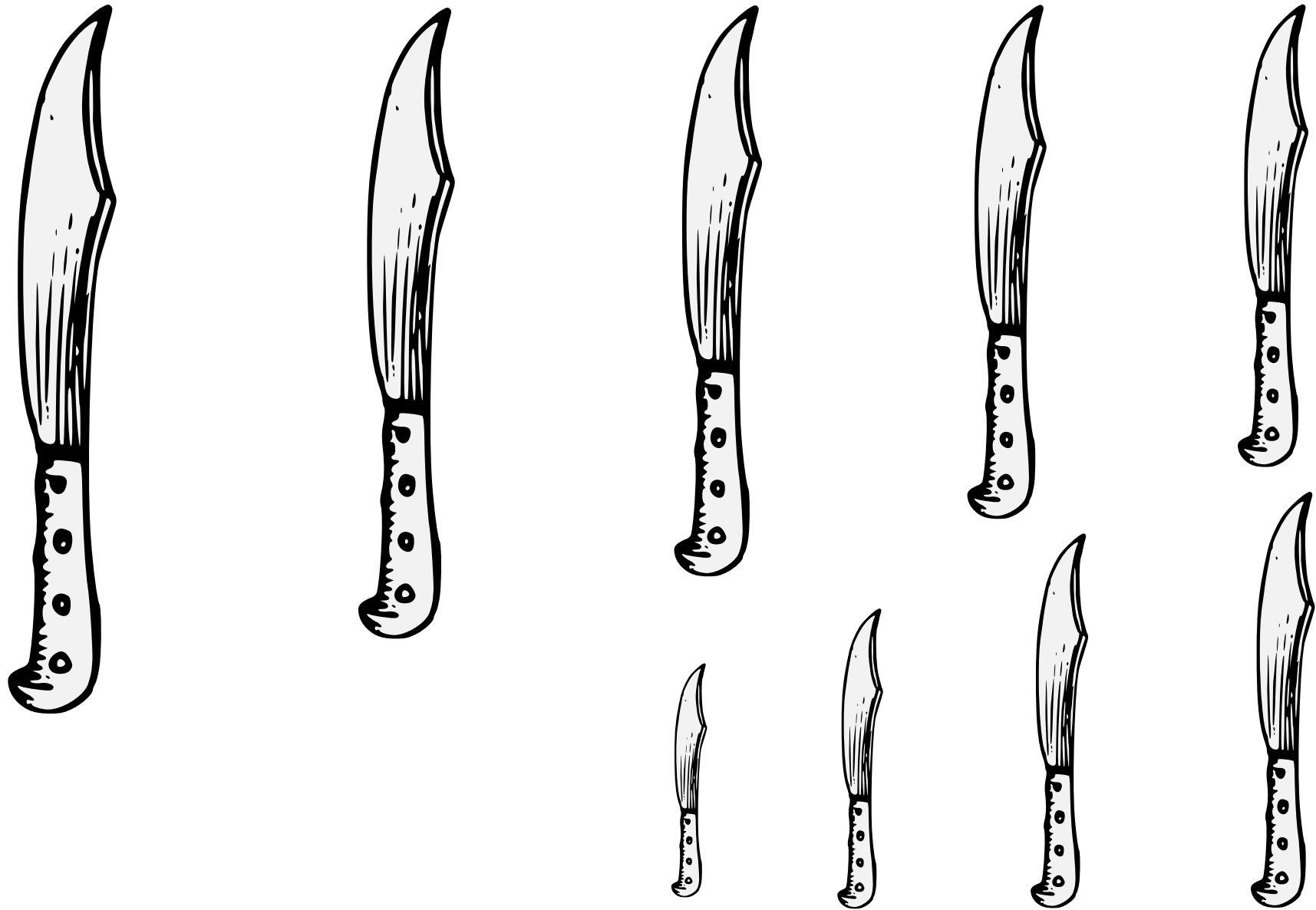

A sharp tool such as one might use in the kitchen.

Default orientation: point to chief, cutting to dexter.

Proper coloration: blade argent, handle Or or brown wood.

Source: Opera Dell'arte Del Cucinare. Artist unknown. (Page 966.)

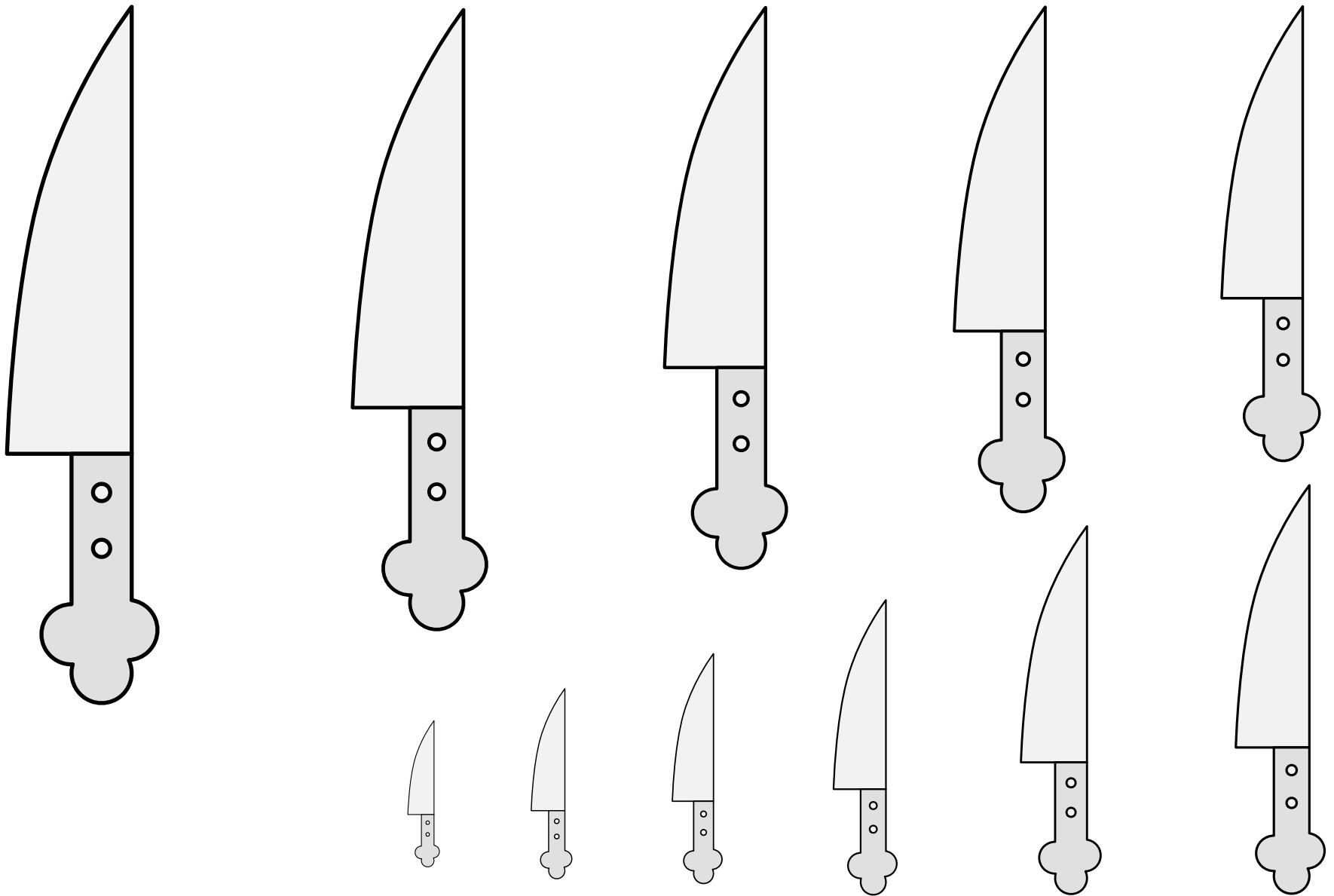

A sharp tool such as one might use in the kitchen.

Default orientation: point to chief, cutting to dexter.

Proper coloration: blade argent, handle Or or brown wood.

Knife (4) 14.103

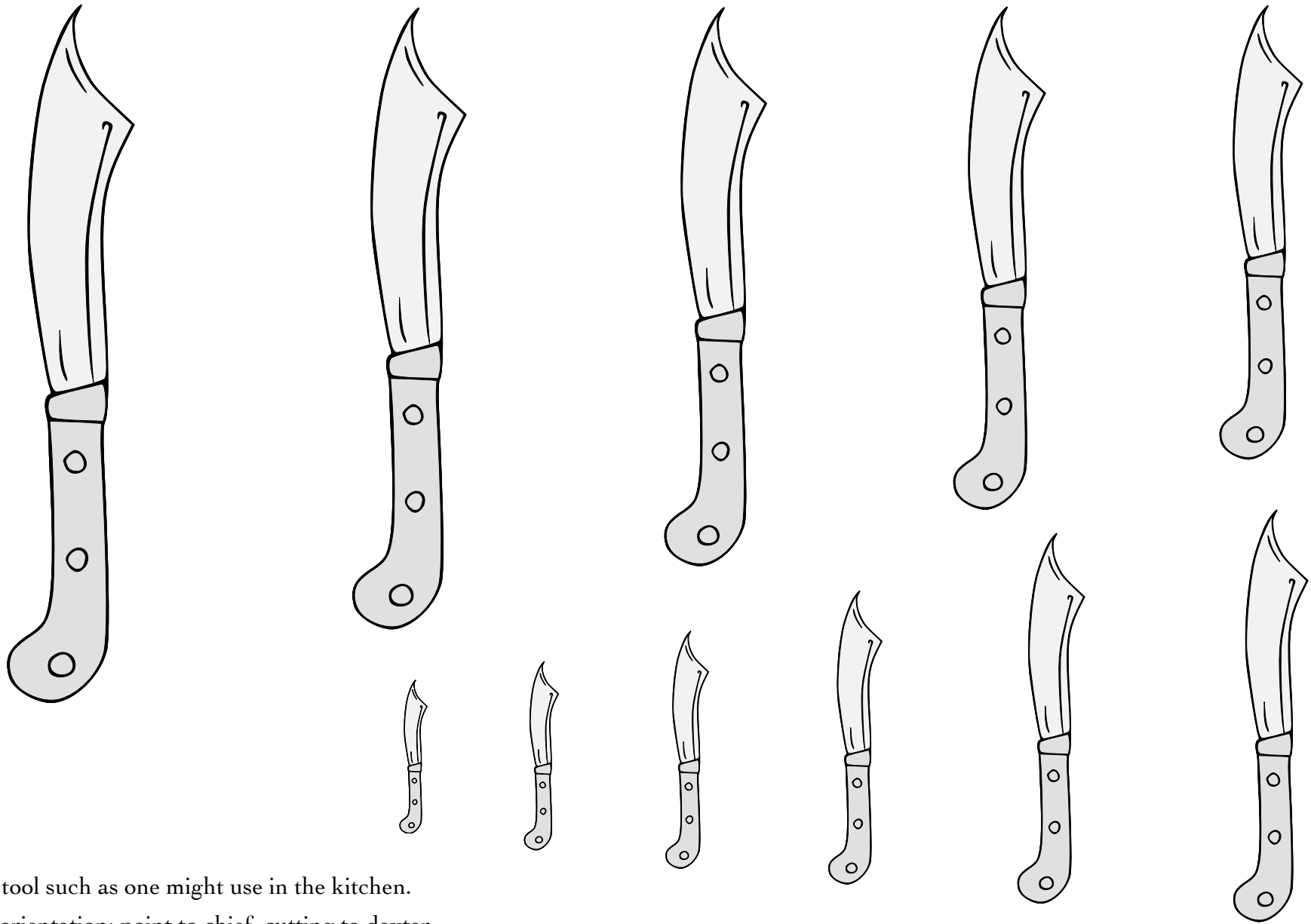

A sharp tool such as one might use in the kitchen.
Default orientation: point to chief, cutting to dexter.
Proper coloration: blade argent, handle Or or brown wood.

Source: The Tudor Pattern Book. Artist unknown.
Adapted by Owen Tegg.

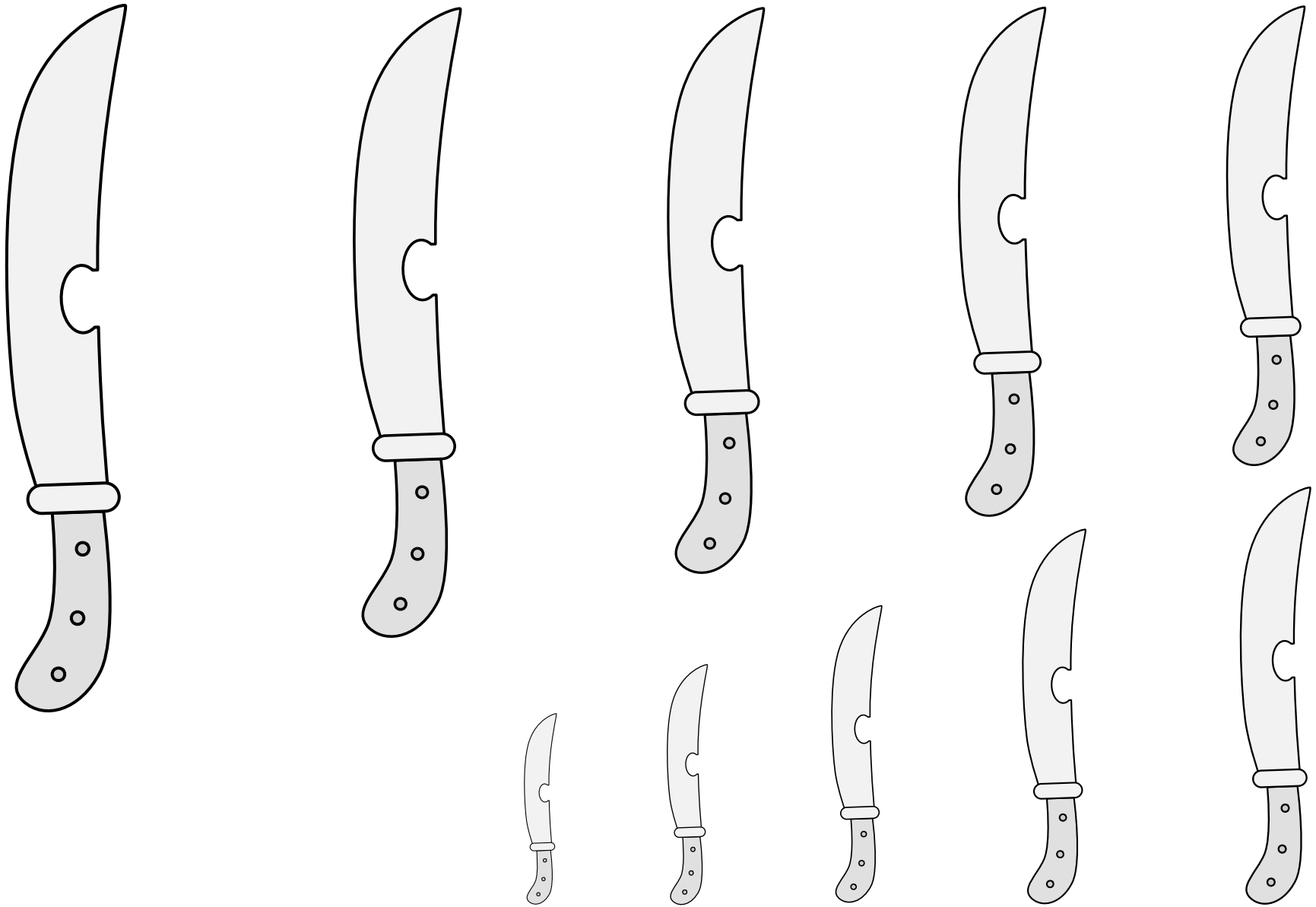

A sharp tool such as one might use in the kitchen.

Default orientation: point to chief, cutting to dexter.

Proper coloration: blade argent, handle Or or brown wood.

Source: BnF MS Allemand 304. Artist unknown. (Page 502.)

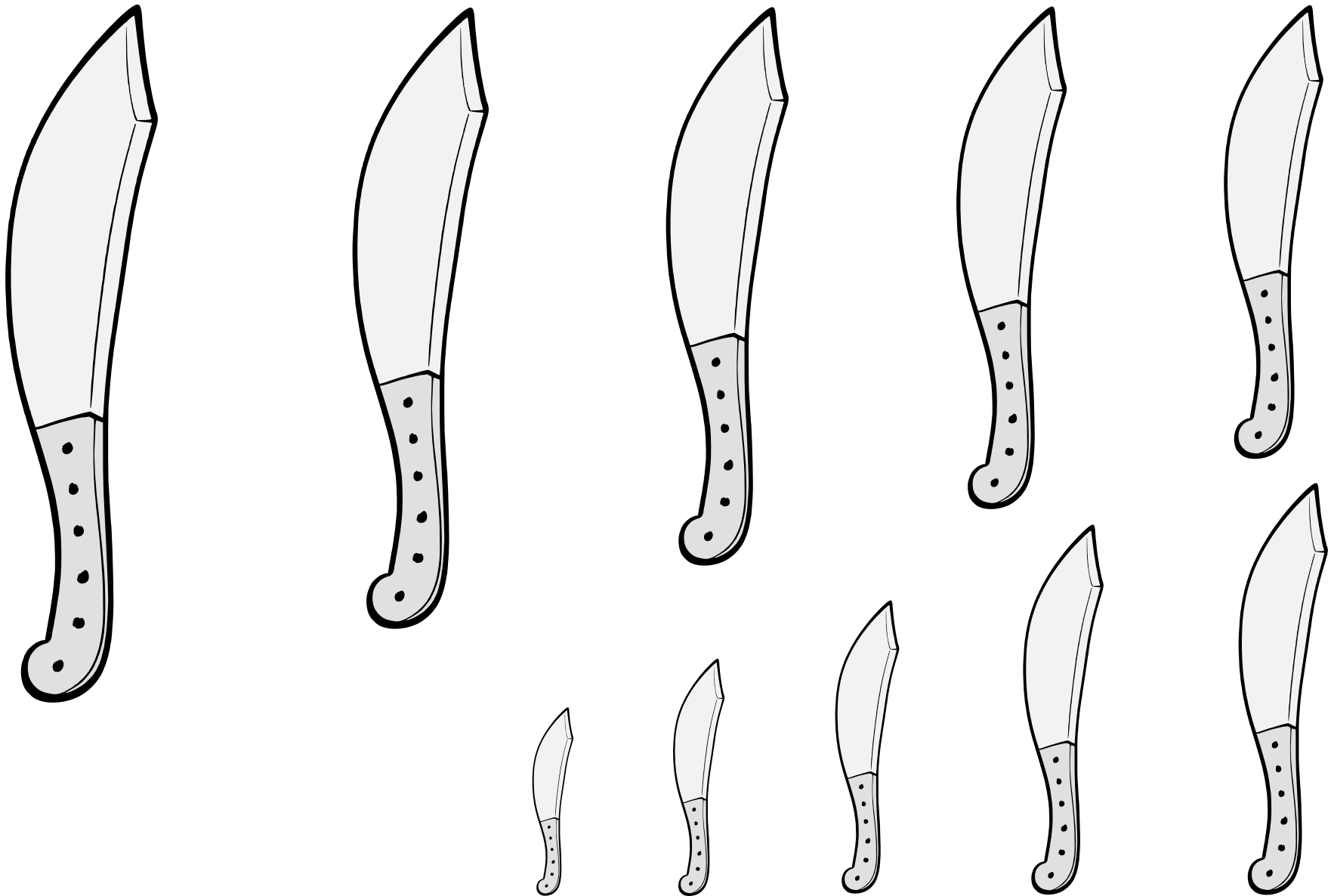

A sharp tool such as one might use in the kitchen.

Default orientation: point to chief, cutting to dexter. Proper coloration: blade argent, handle Or or brown wood.

Source: Stamm- und Wappenbuch des Domherrn Matthaeus Marschall von Pappenheim.
Artist unknown. Adapted by Volusia Zoe.

Knife (7) 14.106



A sharp tool such as one might use in the kitchen.

Default orientation: point to chief, cutting to dexter.

Proper coloration: blade argent, handle Or or brown wood.

Knife, Half-Moon 14.107

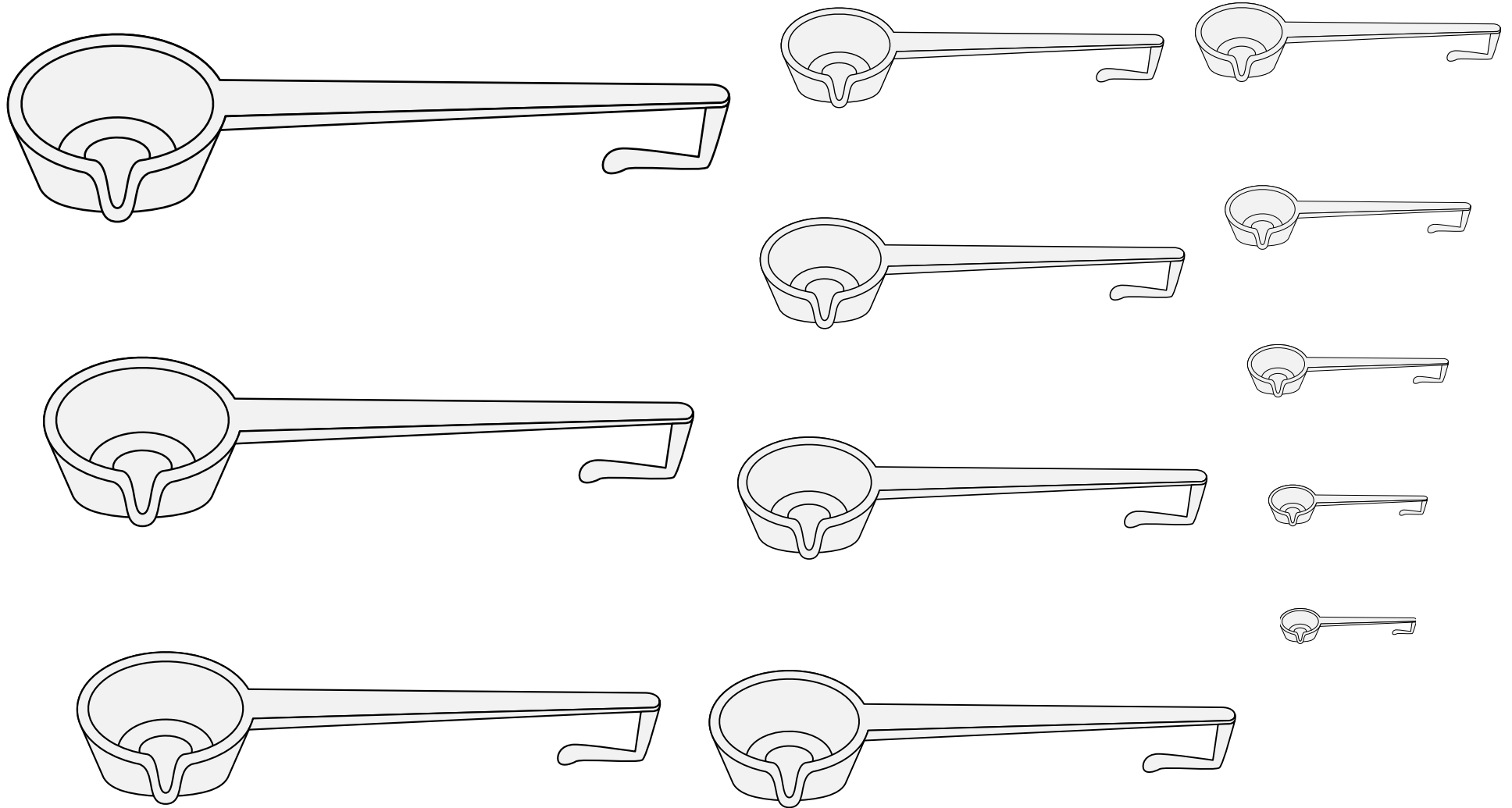

A utensil for serving soup.

Default orientation: fesswise, handle to sinister. No proper coloration.

Source: Insignia Urbium Italiae Septentrionalis. Artist: Unknown.
(Arms of de Cazaviis, folio 137r.)

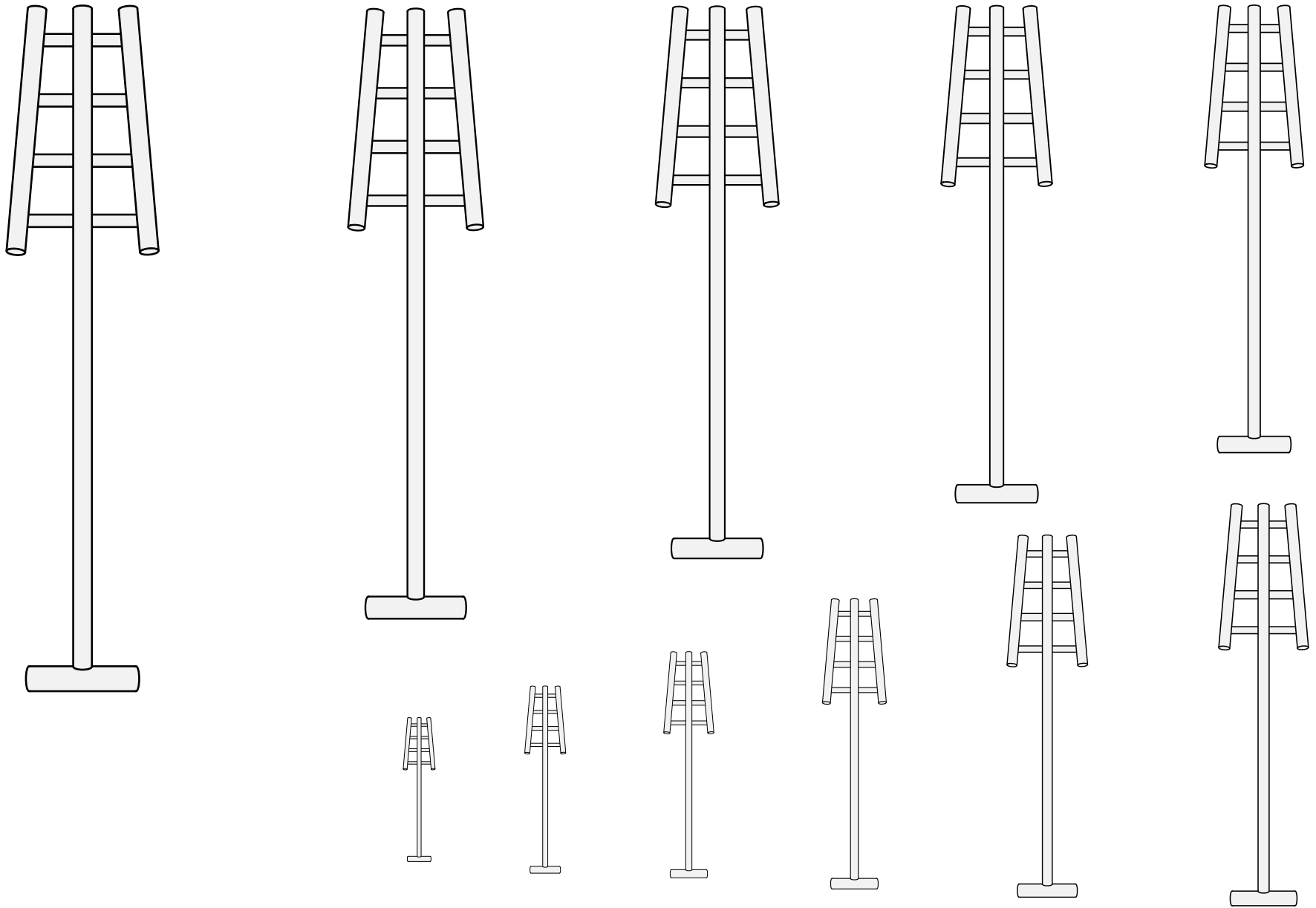

A long wooden implement with crossbars used for stirring a vat of fermenting grain.
Default orientation: head to chief. No proper coloration.

Mash Rake (1) 14.109

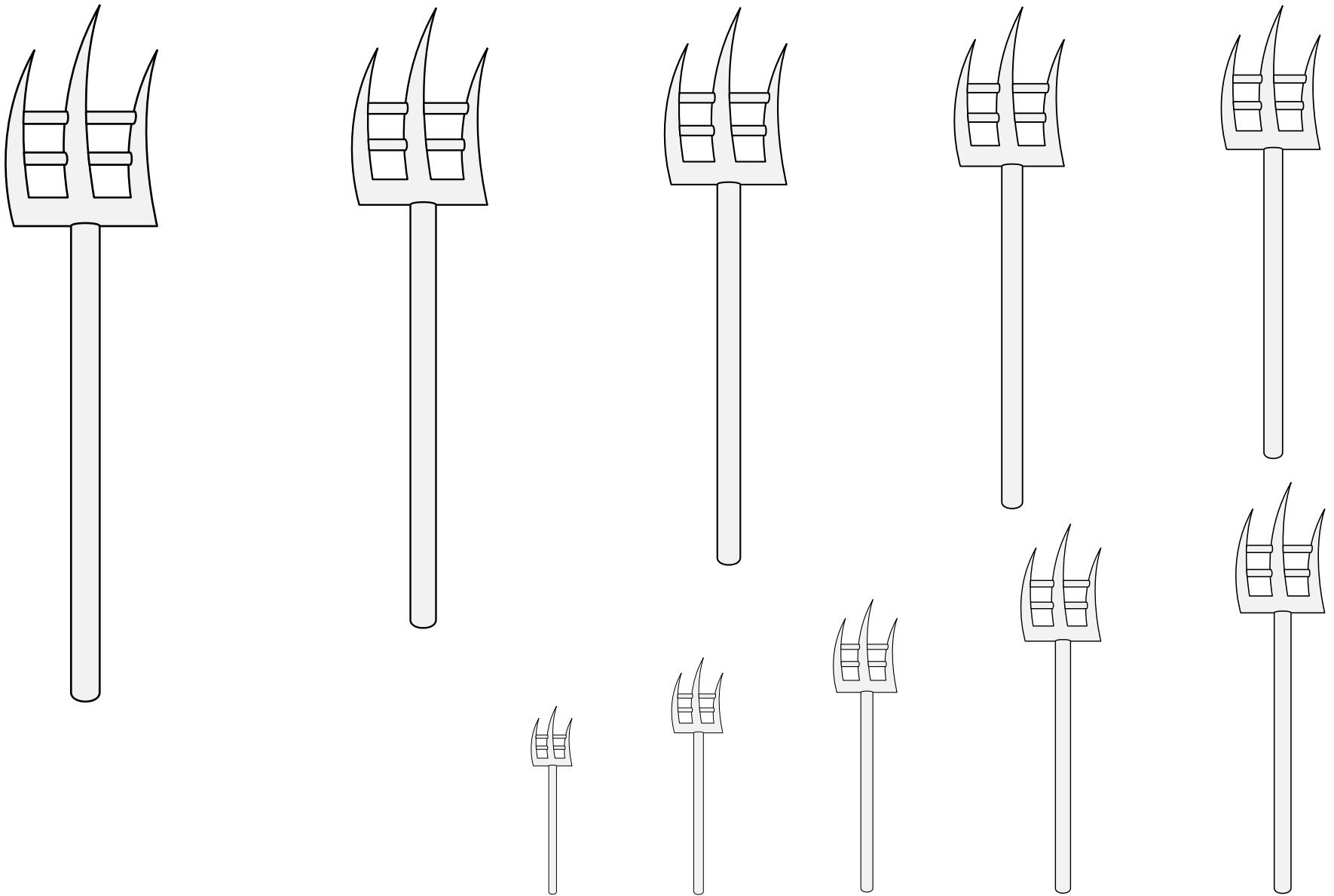

A long wooden implement with crossbars used for stirring a vat of fermenting grain.

Default orientation: head to chief. No proper coloration.

Source: Neustifter Wappenbuch. Artist: Vigil Raber. (Page 47.)

Mash Rake (2) • 14.110

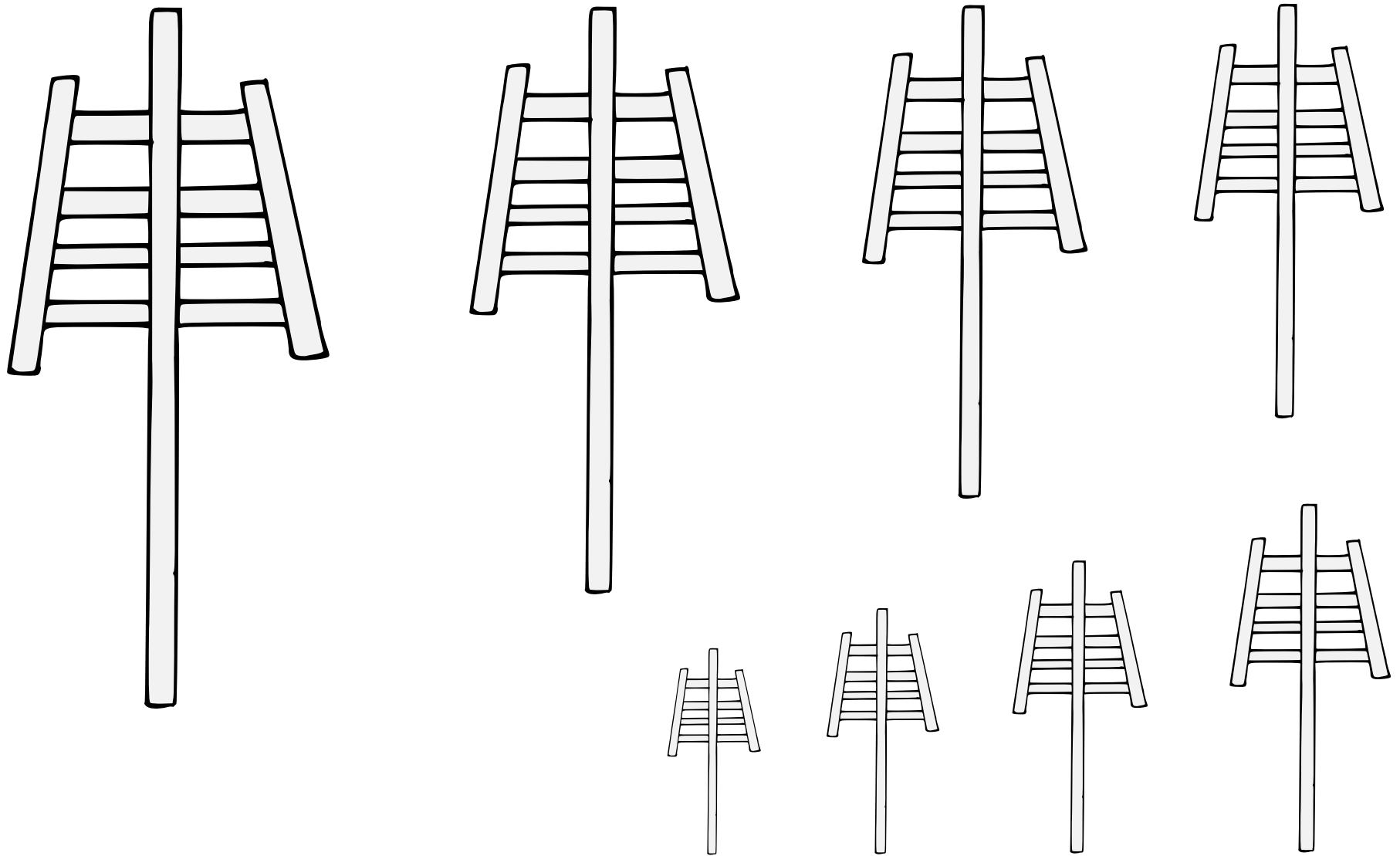

A long wooden implement with crossbars used for stirring a vat of fermenting grain.

Default orientation: head to chief. No proper coloration.

Source: Pennsic 50 Art Tent. Artist: Pennsic 50 Volunteer.

Mash Rake (3) 14.111

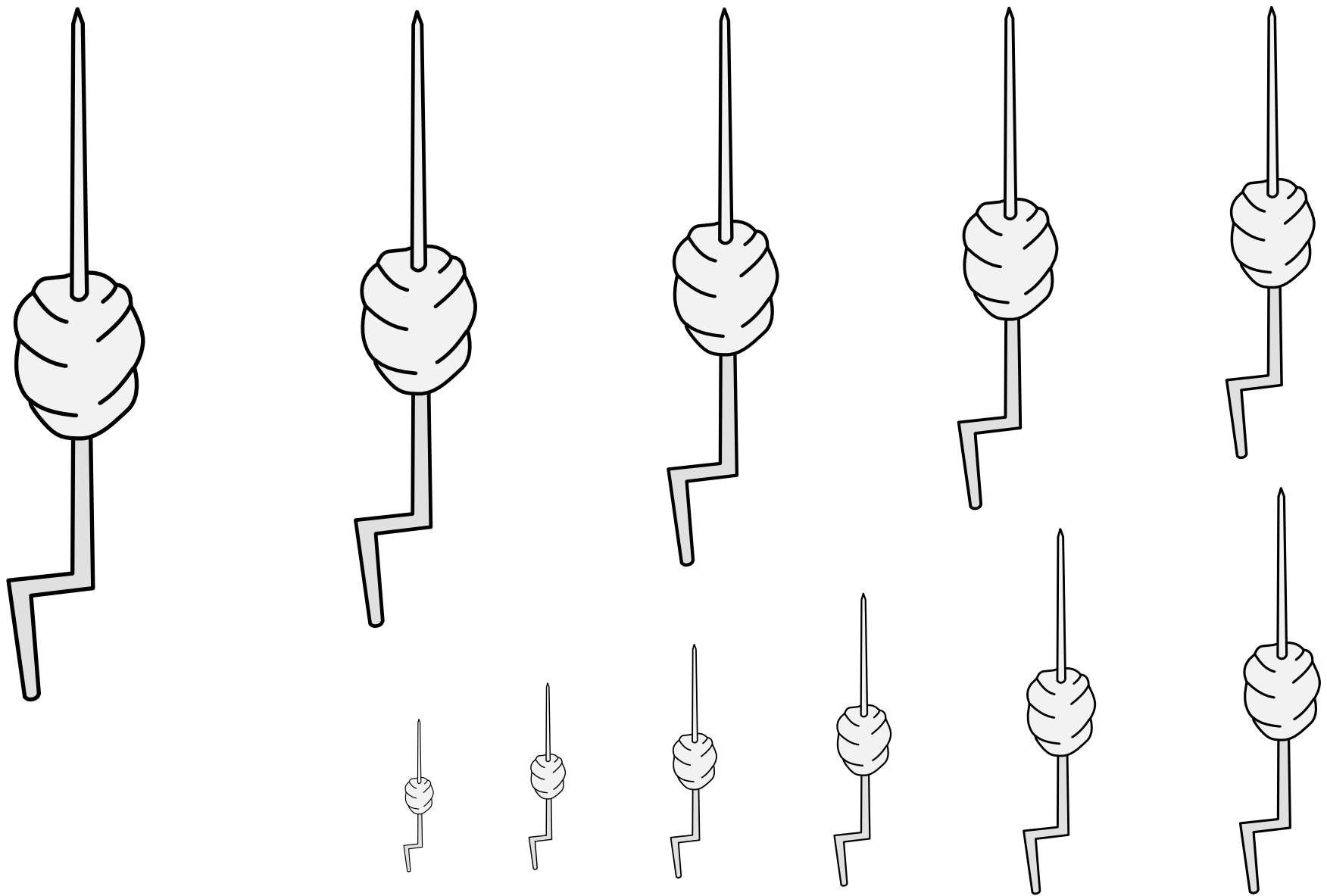

A gob of flesh impaled on a metal skewer for cooking over a fire.

Default orientation: point to chief. No proper coloration.

Source: Stemmario Trivulziano. Artist: Gian Antonio da Tradate.
Adapted by Mathghamhain Ua Ruadháin.

Meat, Spit of (1) 14.112

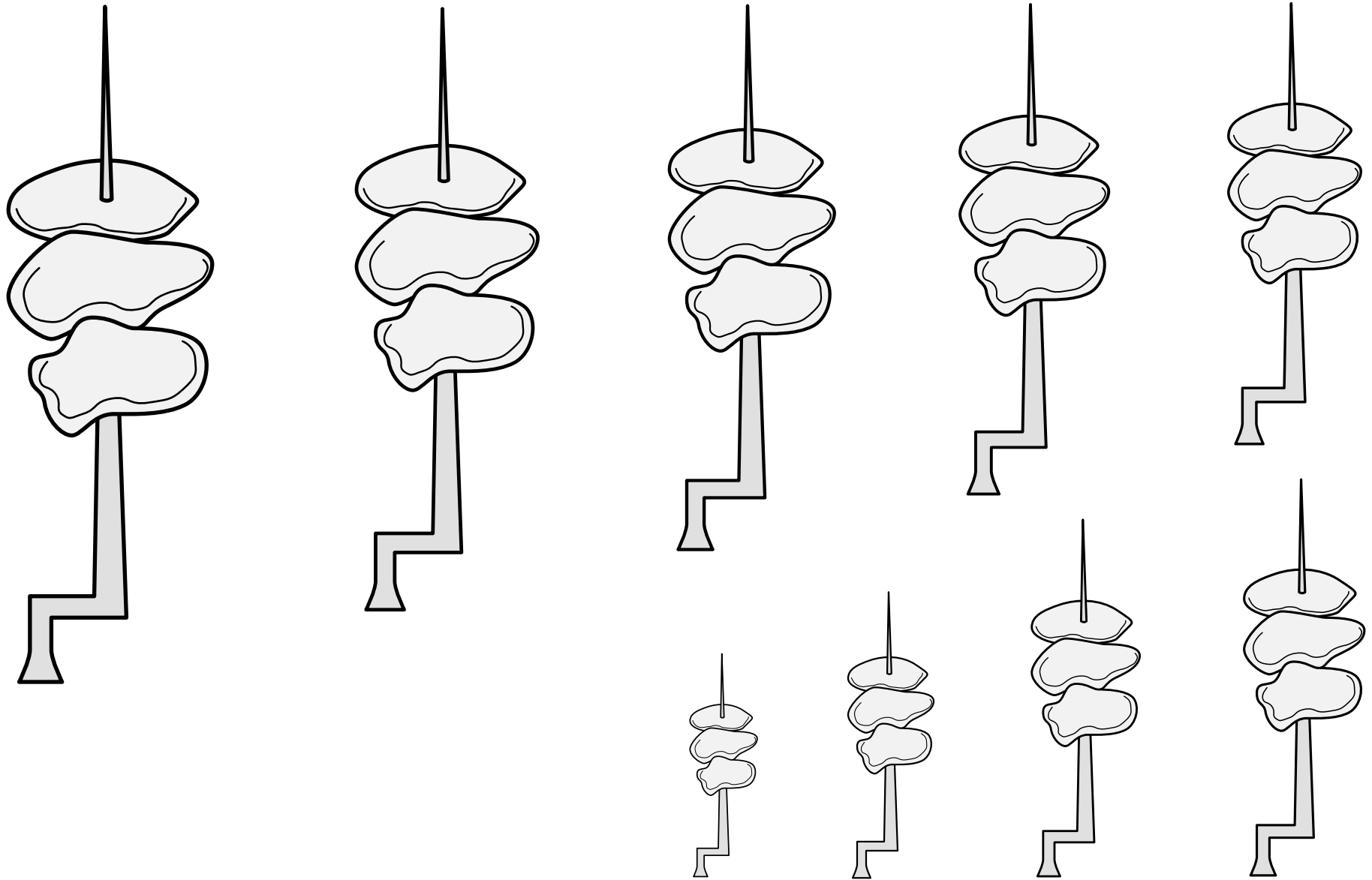

A gob of flesh impaled on a metal skewer for cooking over a fire.

Default orientation: point to chief. No proper coloration.

Source: *Insignia Urbium Italiae Septentrionalis*. (From the arms of de Rostis, fol 361.) Artist unknown. Adapted by Mathghamhain Ua Ruadháin.



A mechanism for crushing or grinding items to powder.

No default orientation. No proper coloration.

Source: Pennsic Traceable Art. Artist: Roana d'Evreux.

Mortar and Pestle (1) 14.114

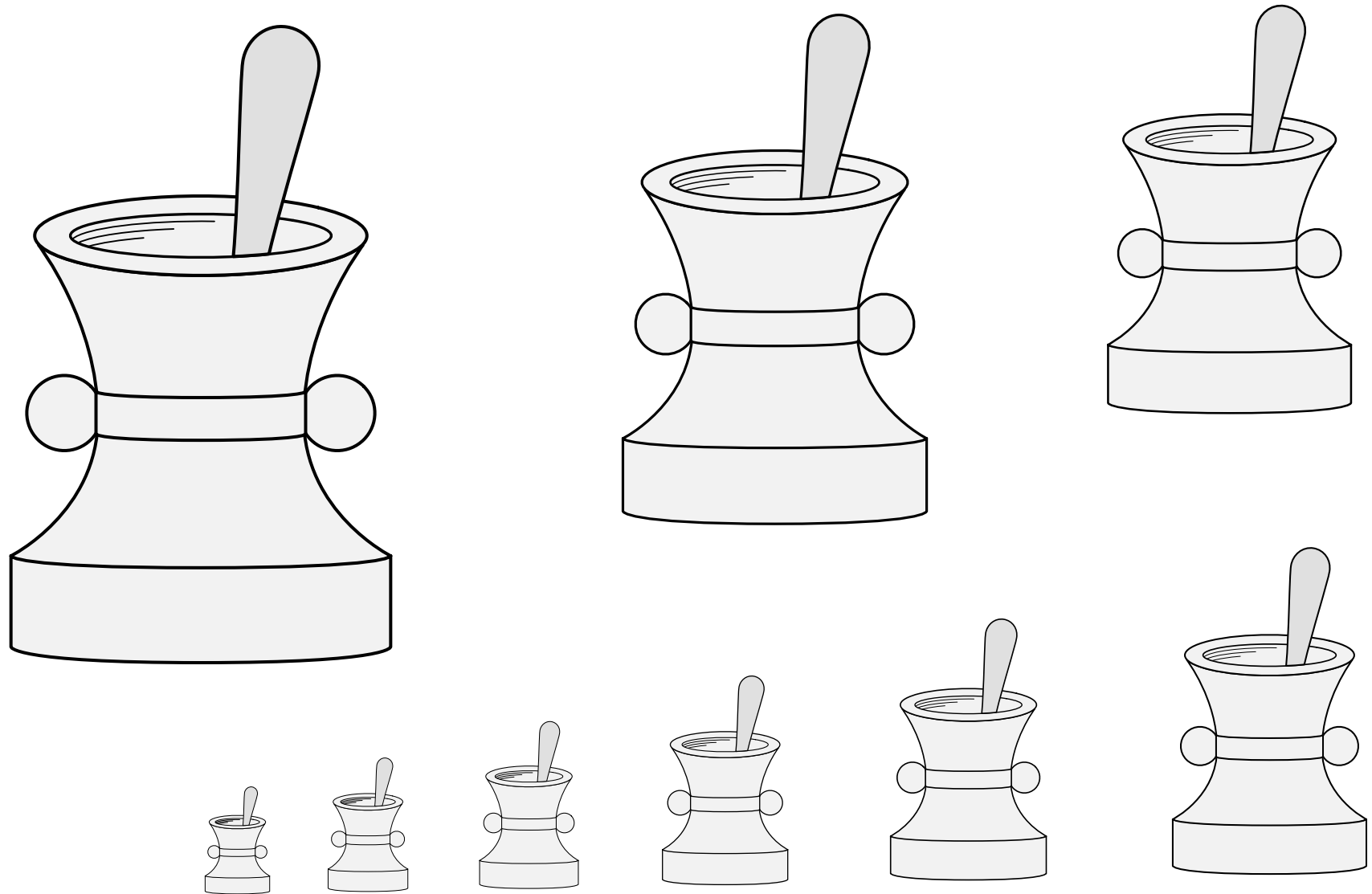

A mechanism for crushing or grinding items to powder.

No default orientation. No proper coloration.

Source: Les Blasons des Communautés d'Apothicaire
au XVIIe Siècle. Artist unknown.

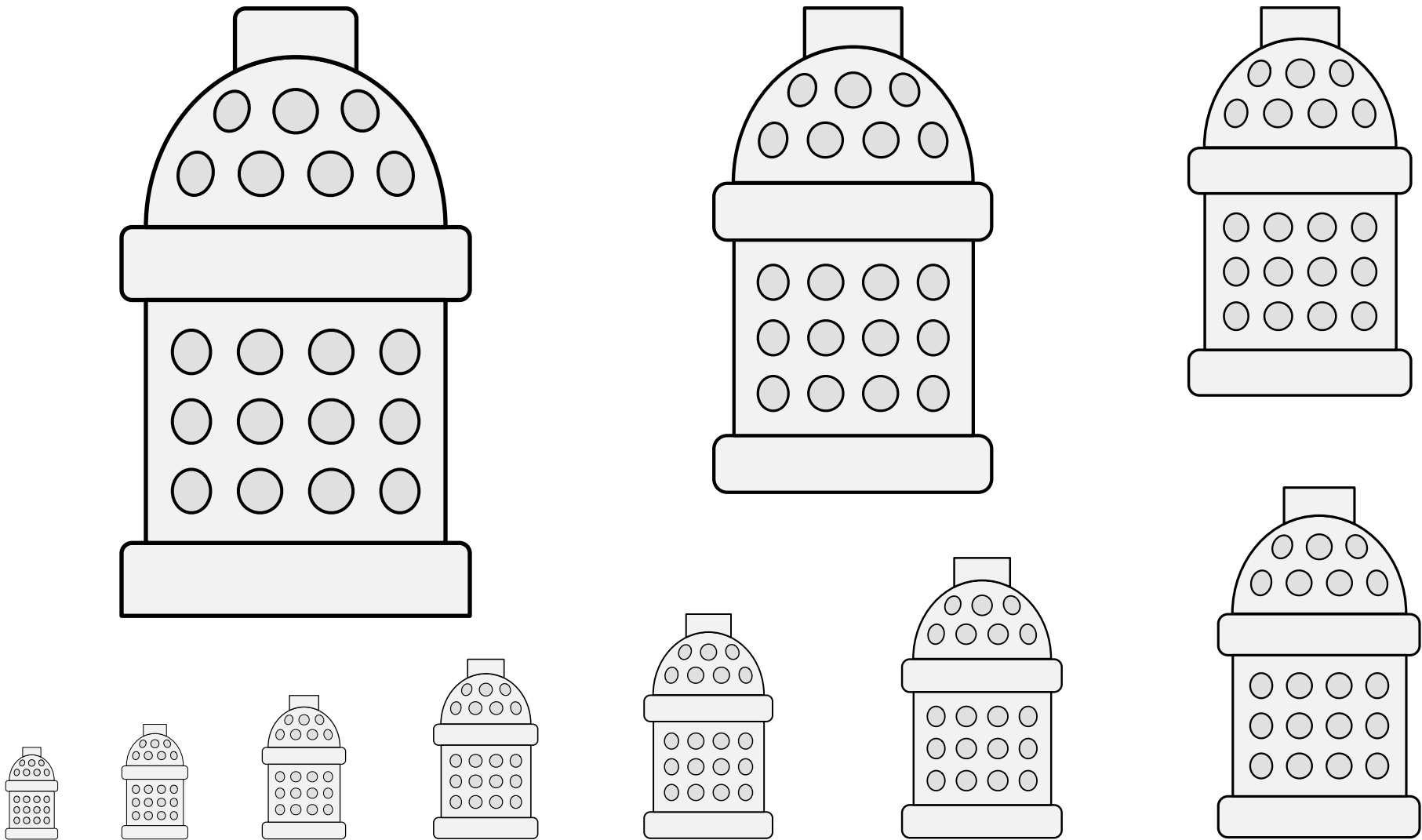

A large baking oven.

Default orientation: dome to chief. No proper coloration.

This depiction has an outer shell pierced by ventilation holes, whose tincture may be blazoned separately.

Source: Zurich Roll. Artist unknown.

Oven, Domed (1) 14.116

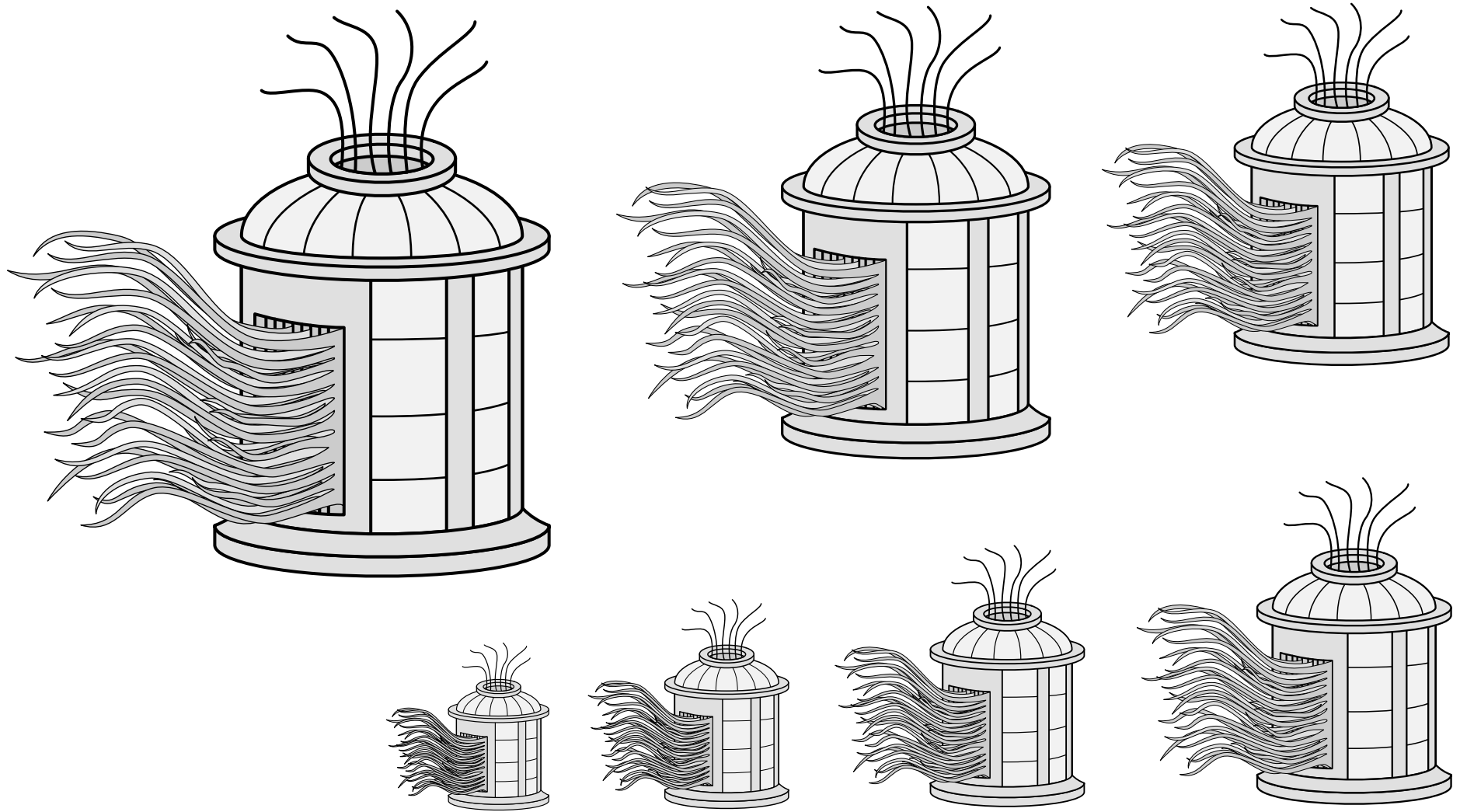

A large baking oven.

Default orientation: dome to chief. No proper coloration.

This depiction includes flames issuant from its door.

Source: Donaueschinger Wappenbuch. Artist unknown.

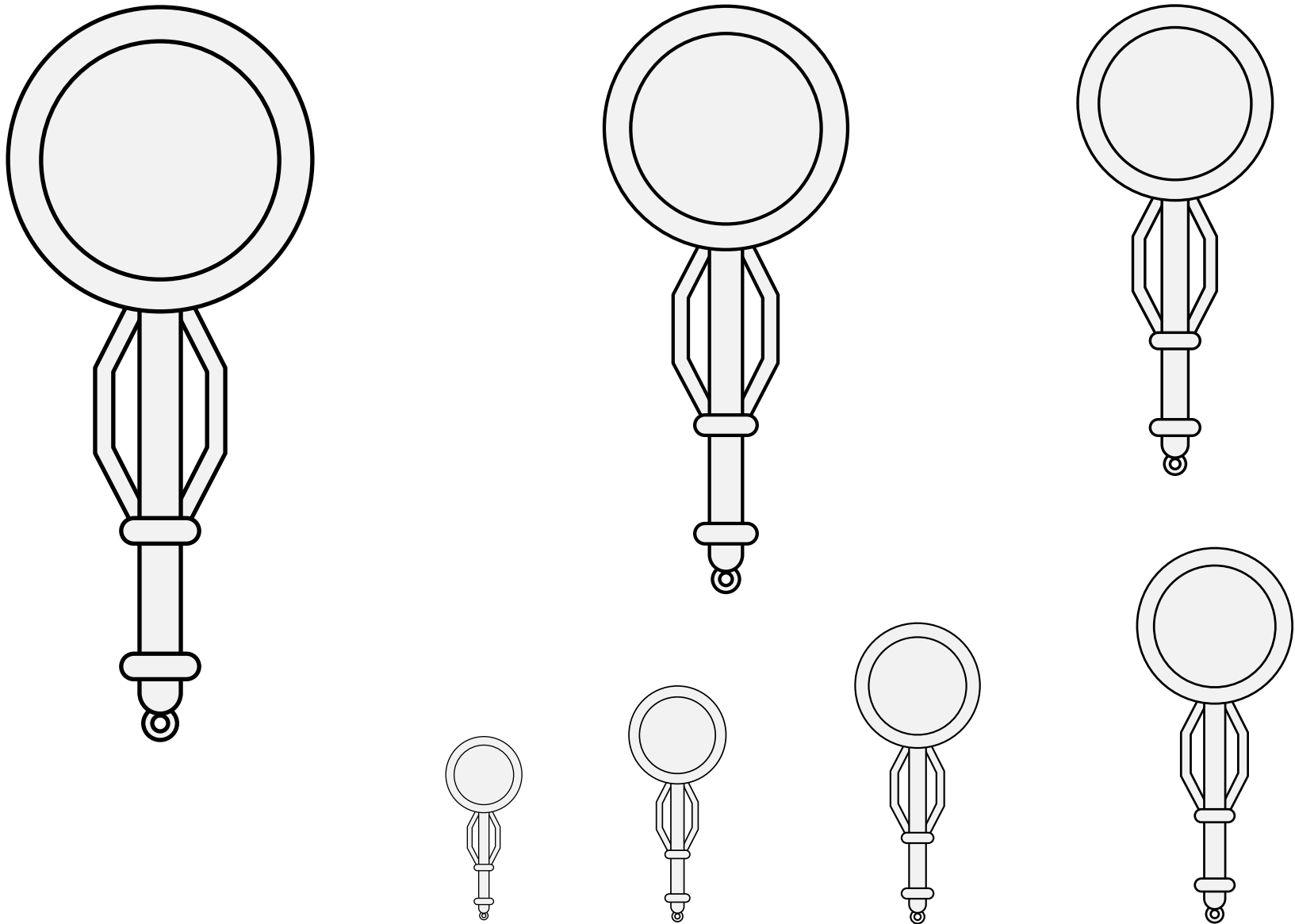

A skillet.

Default orientation: palewise, handle to base. No proper coloration.

Source: Viking Answer Lady SVG Images For Heraldists. Artist: Gunnvôr silfráhr.

Pan, Frying (1) 14.118

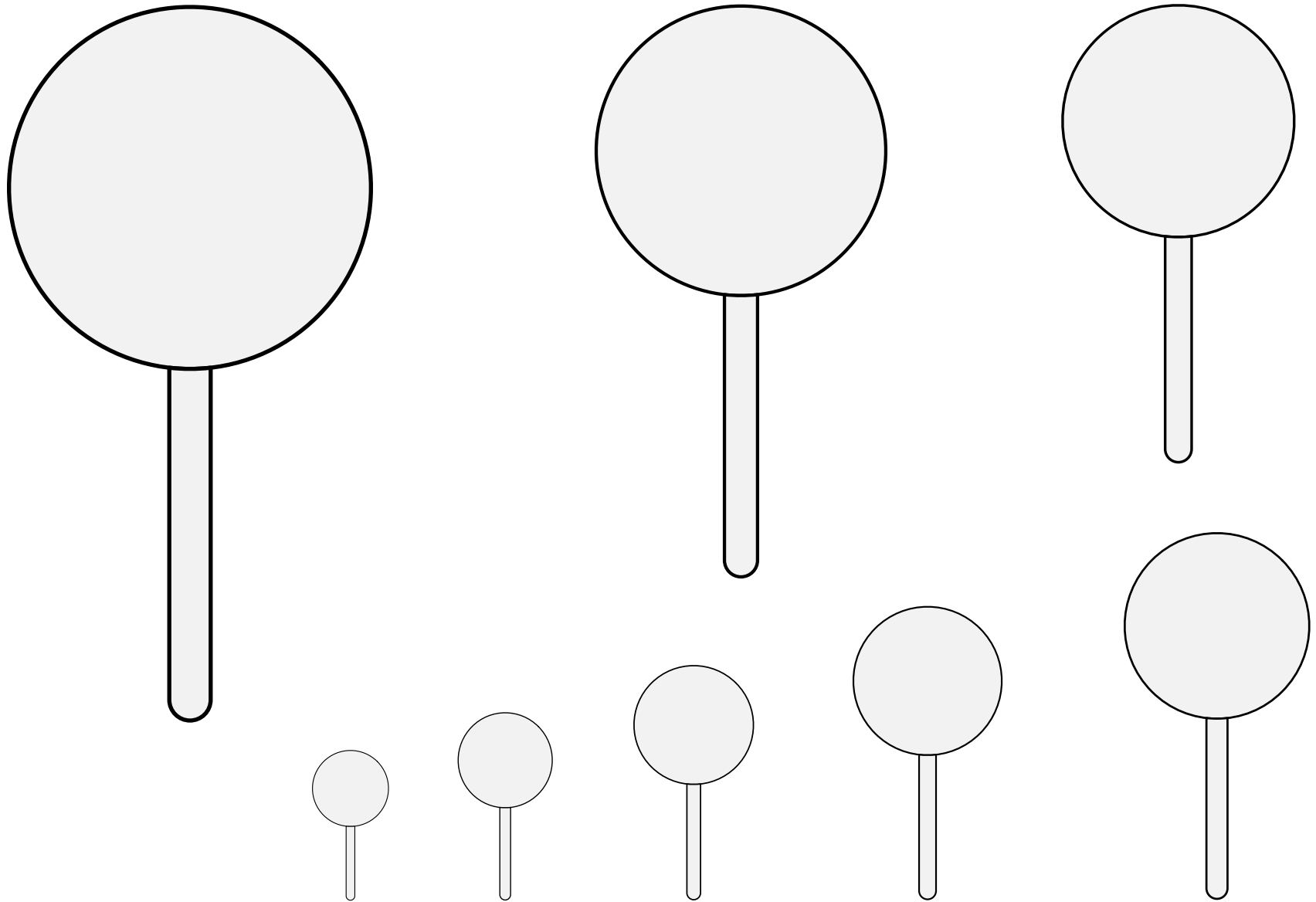

A skillet.

Default orientation: palewise, handle to base. No proper coloration.

Adapted from an image of the arms of Padilla on the tomb of Sir Lewis Robessart.

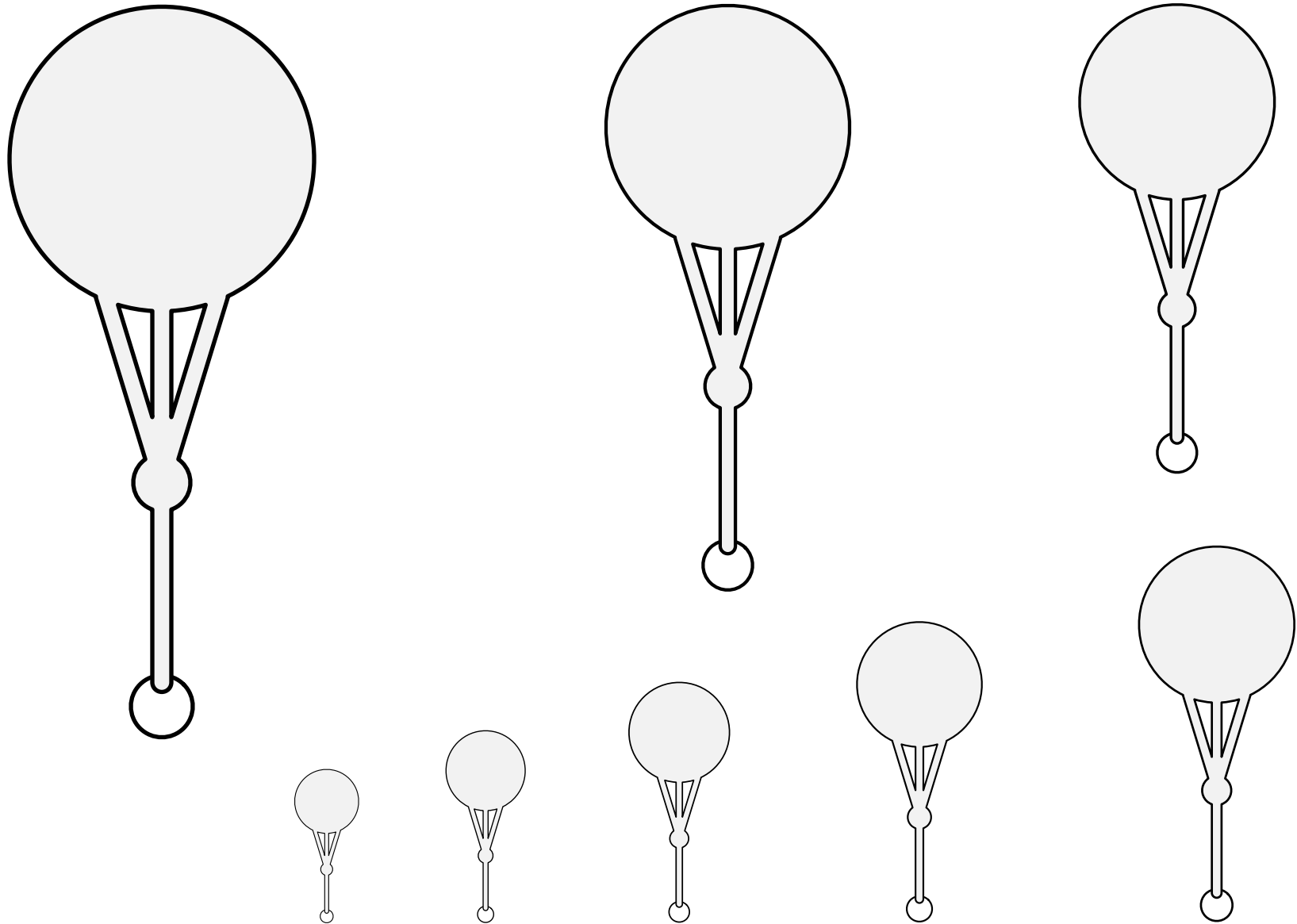

A skillet.

Default orientation: palewise, handle to base. No proper coloration.

Source: Stemmario Trivulziano. Artist: Gian Antonio da Tradate.
(Page 282, arms of Padilla.)

Pan, Frying (3) 14.120

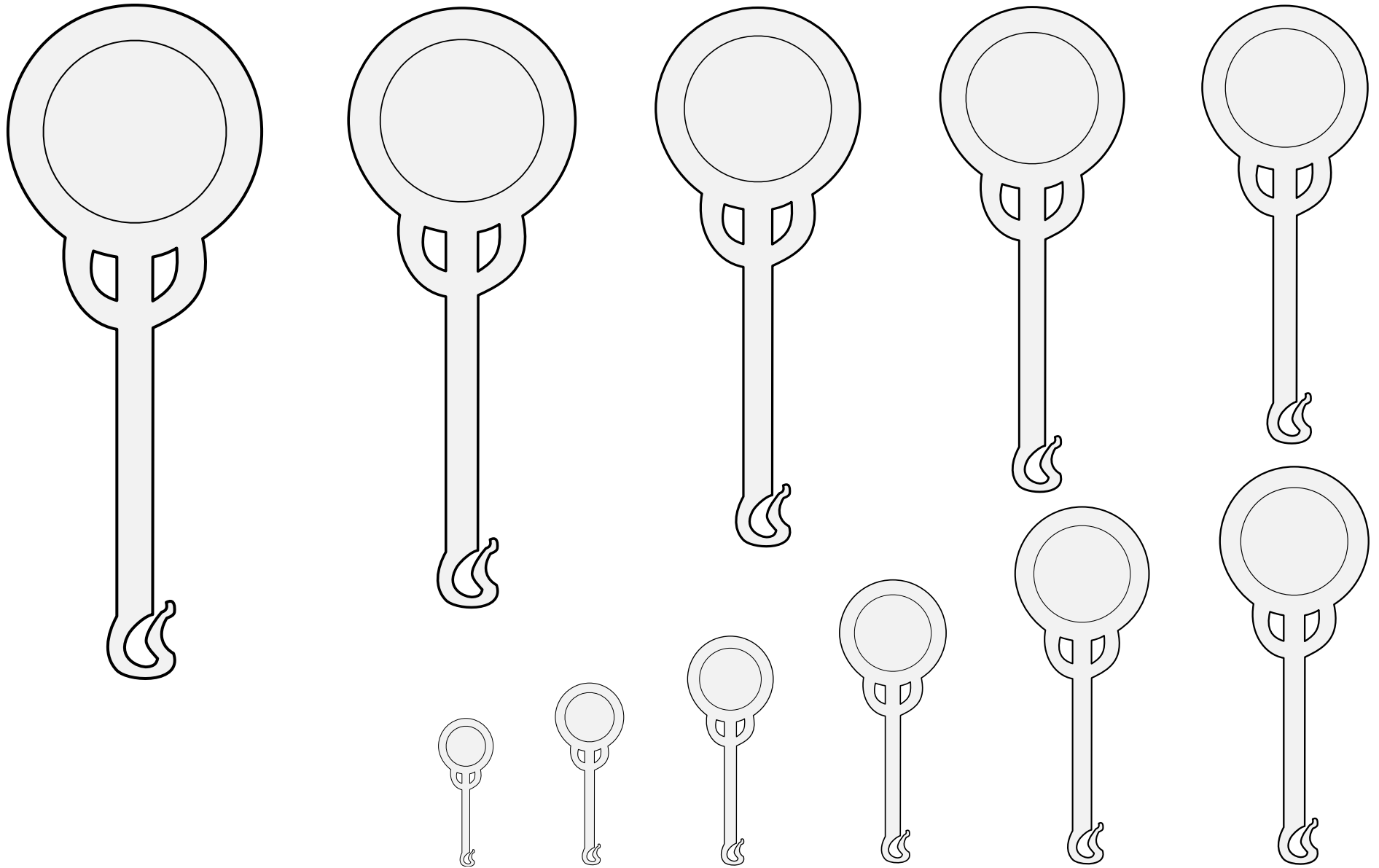

A skillet.

Default orientation: palewise, handle to base. No proper coloration.

Source: *Traité de Blason et Recueil d'Armoiries*.
Artist unknown. Adapted by Vémundr Syvursson.

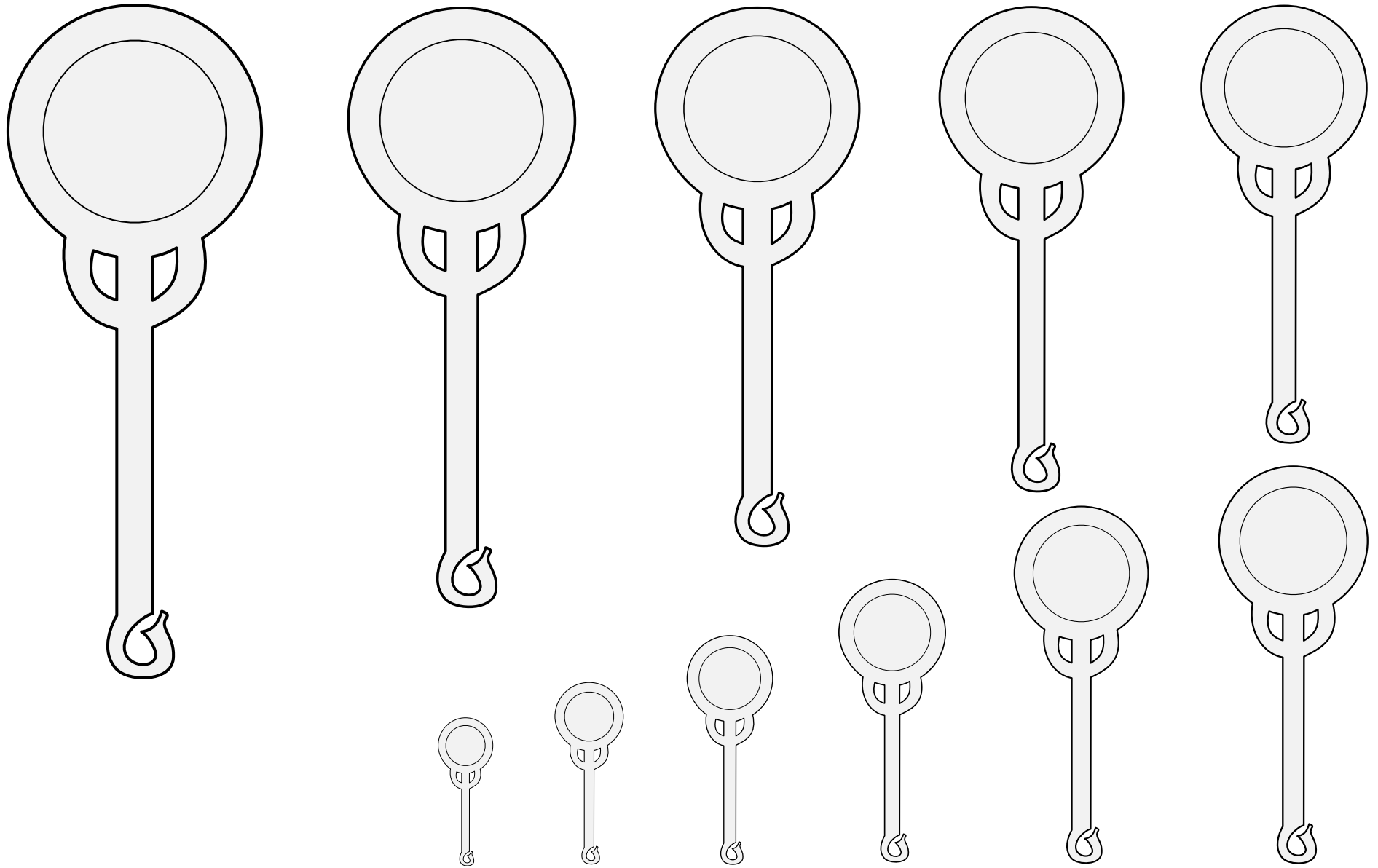

A skillet.

Default orientation: palewise, handle to base. No proper coloration.

Source: *Traité de Blason et Recueil d'Armoiries*.
Artist unknown. Adapted by Vémundr Syvursson.

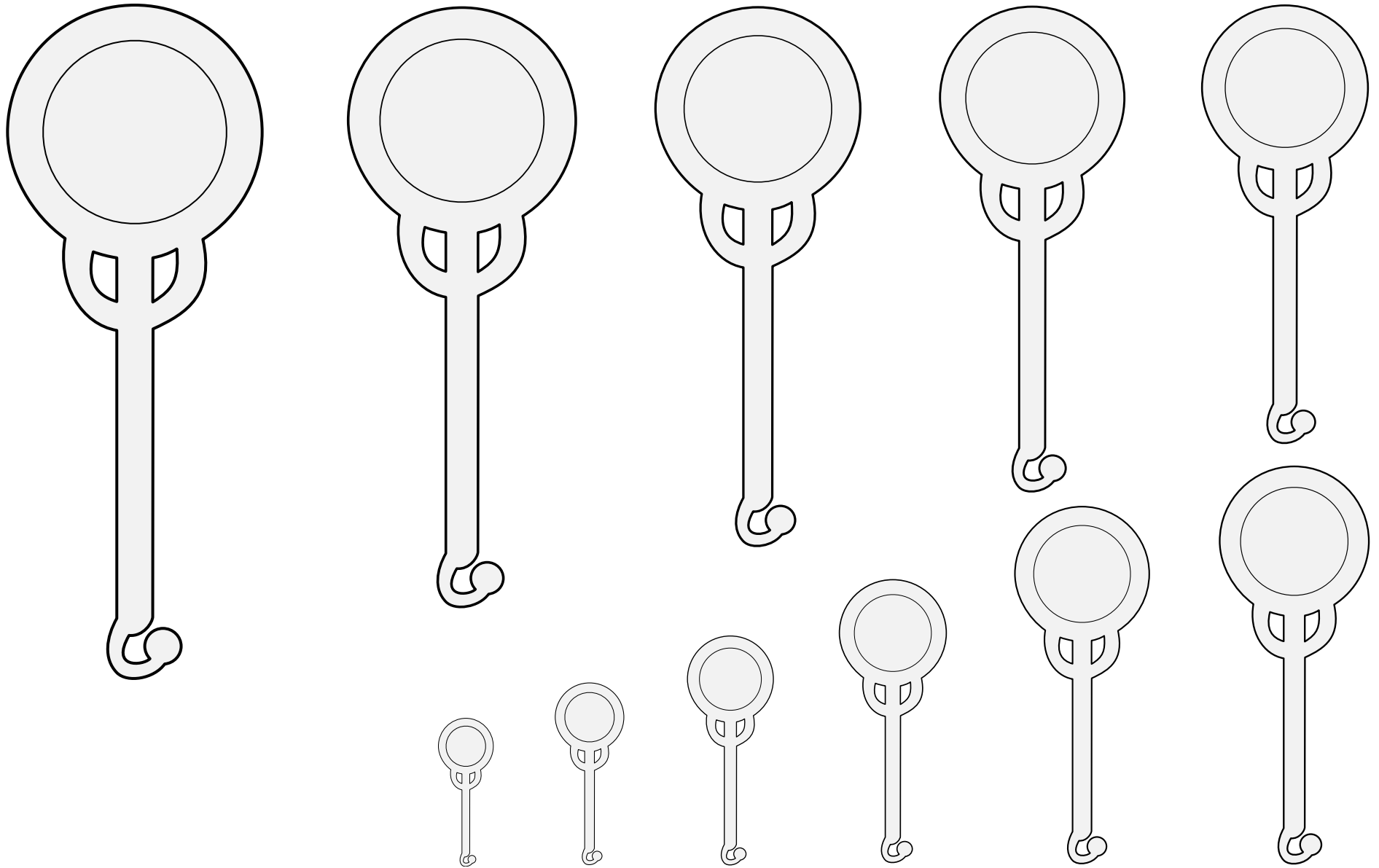

A skillet.

Default orientation: palewise, handle to base. No proper coloration.

Source: *Traité de Blason et Recueil d'Armoiries*.
Artist unknown. Adapted by Vémundr Syvursson.

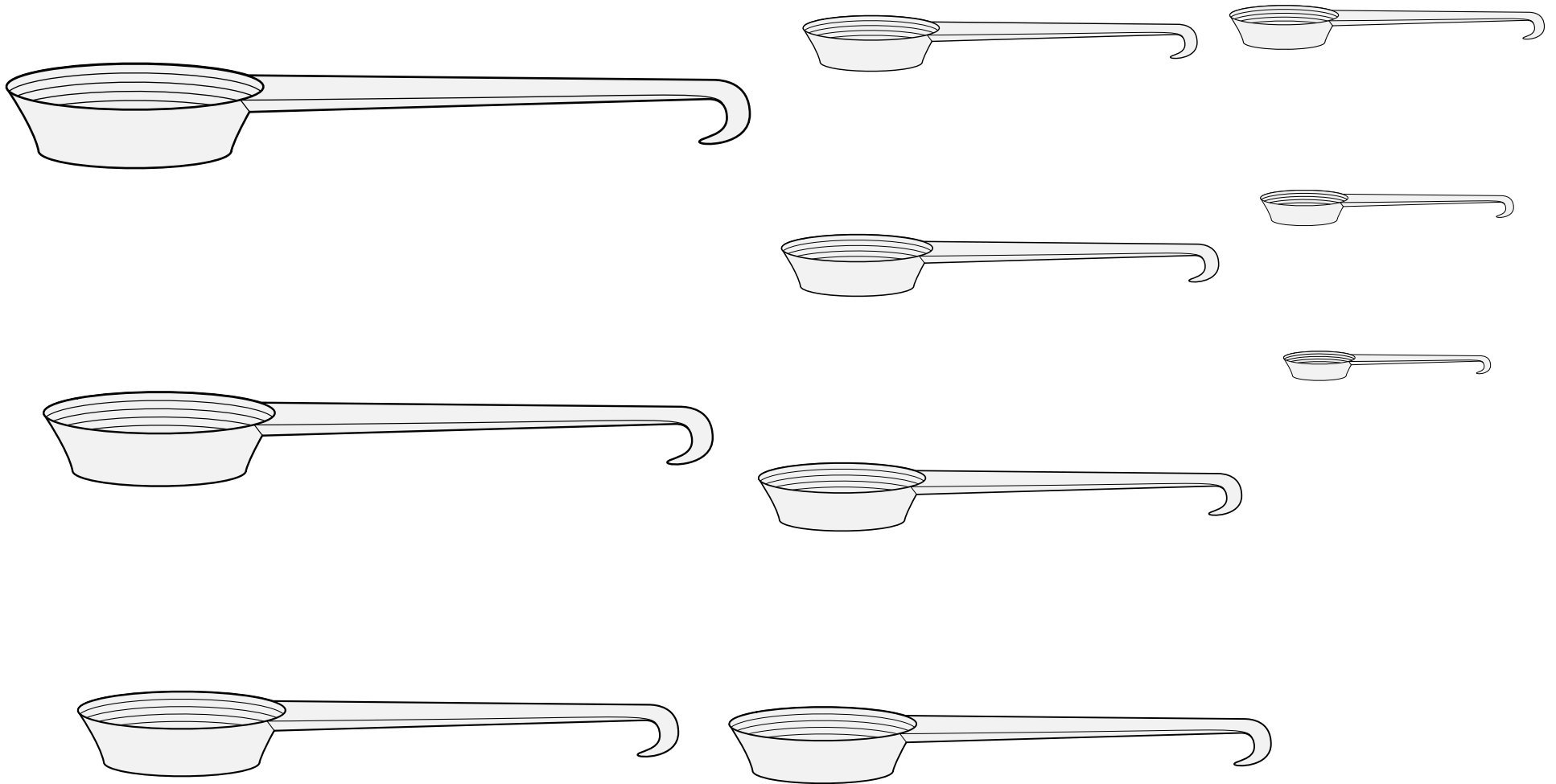

A skillet.

Default orientation: palewise, handle to base. No proper coloration.

Source: Wappenbuch der Arlberg-Bruderschaft.
Artist: Vigil Raber. (Page 402, arms of Kuchler.)

Pan, Frying, Fesswise 14.124

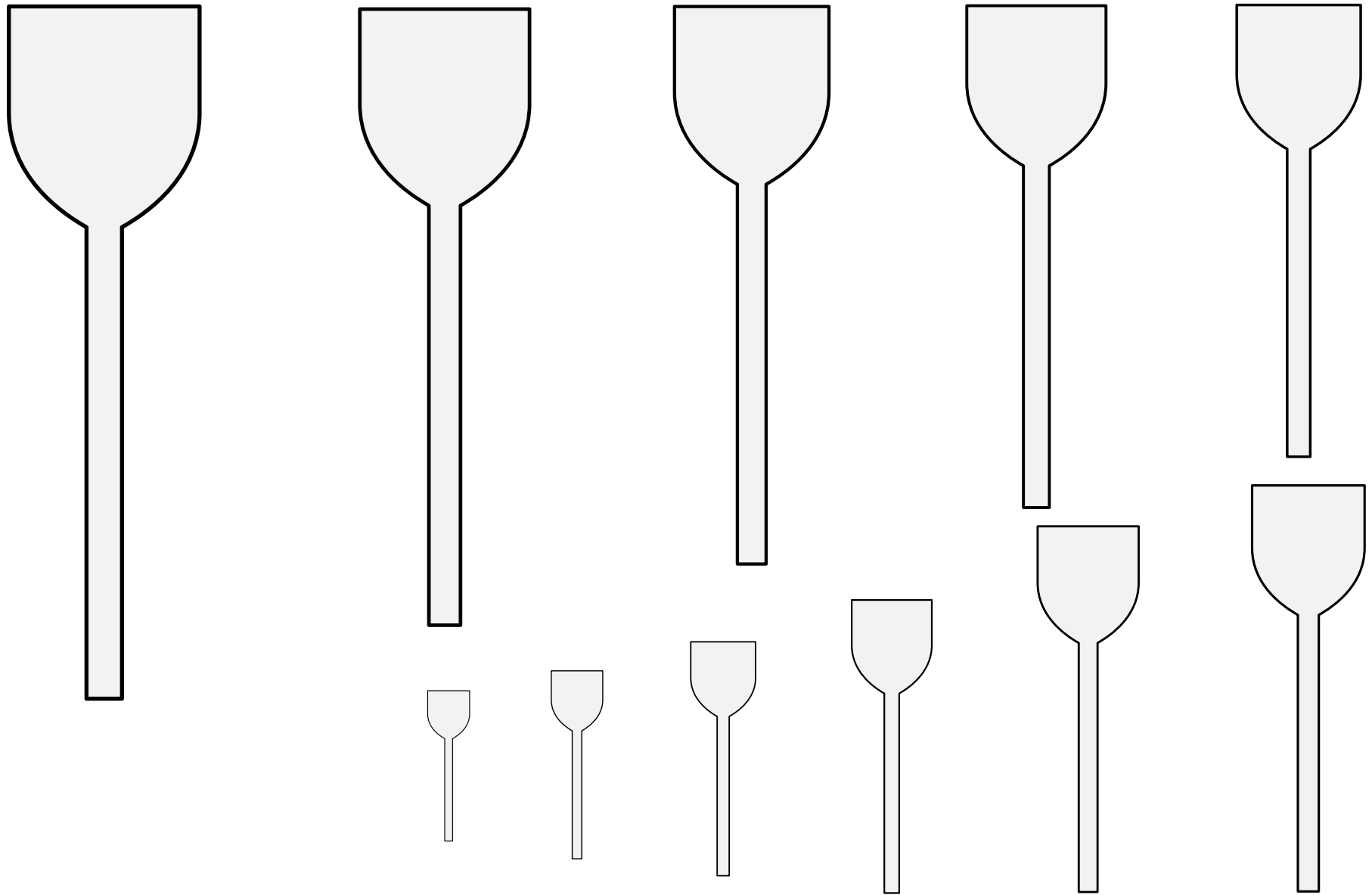

A long wooden spatula used to move bakery products in and out of an oven.

Default orientation: palewise, handle to base. No proper coloration.

Often drawn with several roundels on the flat end representing loaves or cakes.

Source: A Glossary of Terms Used in Heraldry. Artist: James or Irene Parker.

Peel, Baker's (1) 14.125

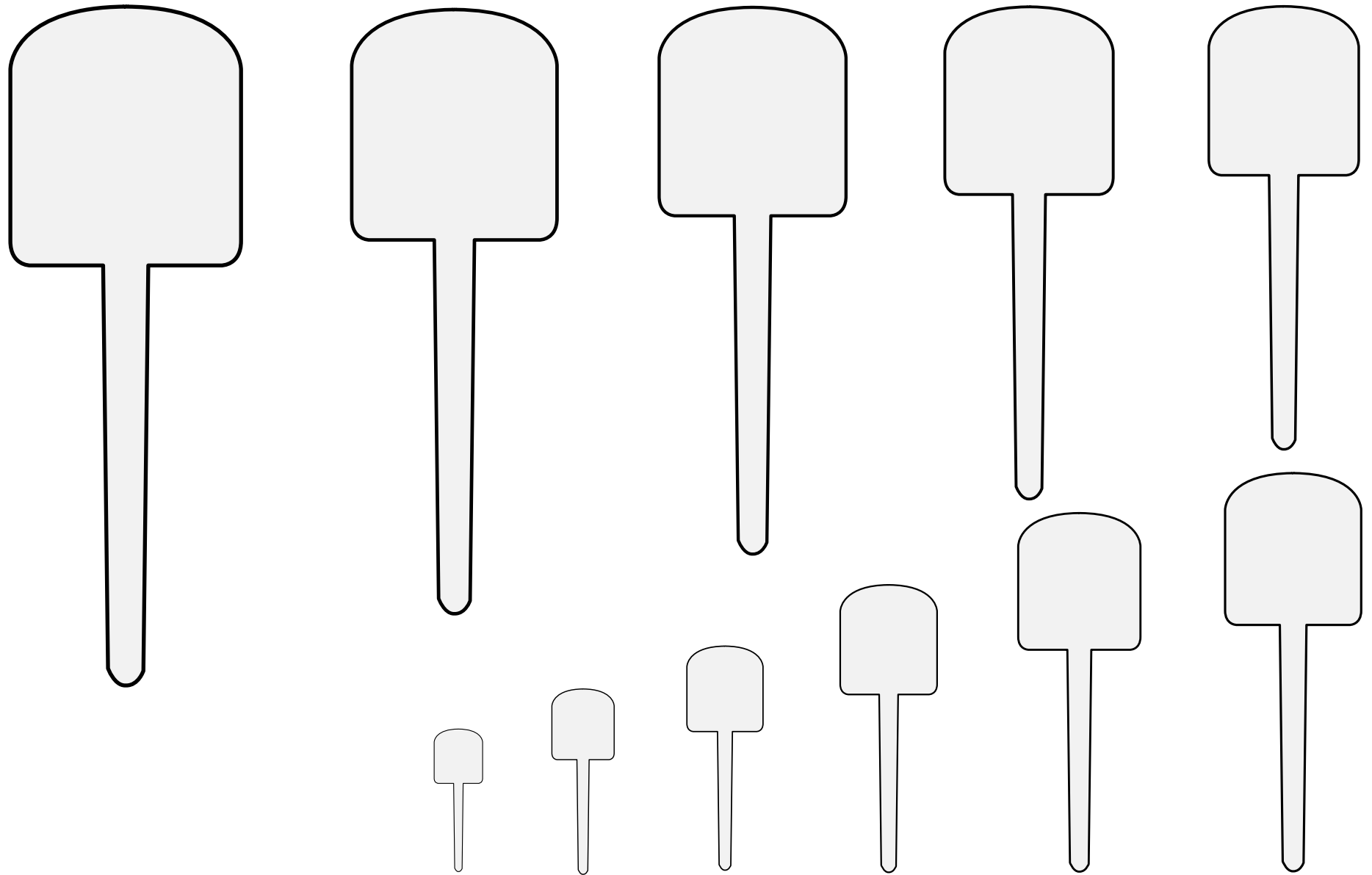

A long wooden spatula used to move bakery products in and out of an oven.
Default orientation: palewise, handle to base. No proper coloration.
Often drawn with several roundels on the flat end representing loaves or cakes.

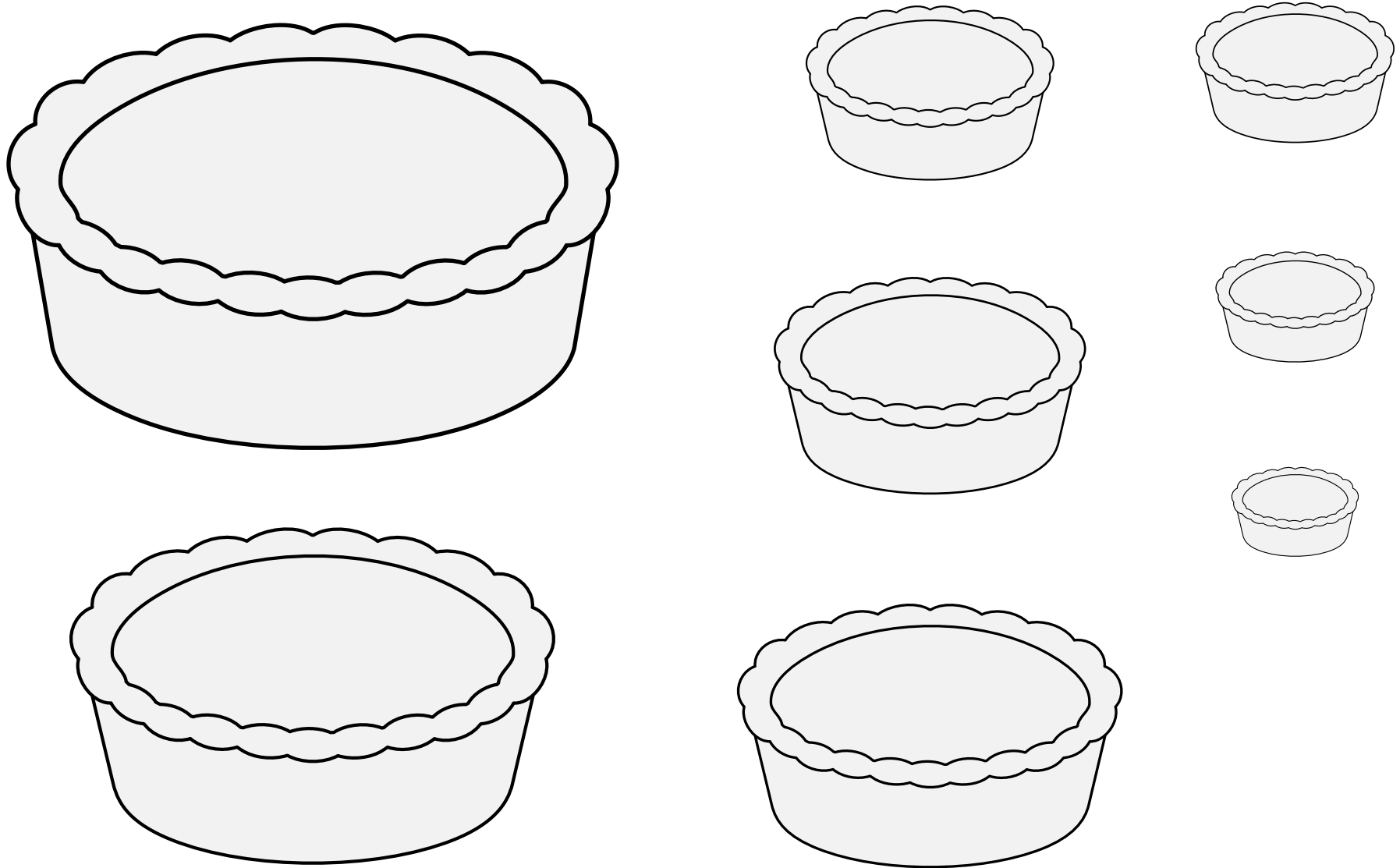

A baked food item with a filling surrounded by a pastry shell, or "coffin."

Default orientation: palewise, perhaps somewhat trian. No proper coloration.

Artist: Mathghamhain Ua Ruadháin. Adapted from an image held by Archäologisches Landesmuseum Baden-Württemberg showing bakers with a mobile oven at the Council of Constance.



A container used to carry and pour water or other fluids.
Default orientation: palewise, spout to dexter. No proper coloration.
Source: Pennsic Traceable Art. Artist unknown.

Pitcher (1) • 14.128



A container used to carry and pour water or other fluids.

Default orientation: palewise, spout to dexter. No proper coloration.

Source: Viking Answer Lady SVG Images For Heraldists. Artist: Gunnvôr silfráhr.



A container for carrying and pouring water.

Default orientation: palewise, spout to dexter. No proper coloration.

An ornate pitcher may be blazoned a "ewer."

Source: Viking Answer Lady SVG Images For Heraldists. Artist: Gunnvôr silfráðarr.



A container for carrying and pouring water.

Default orientation: palewise, spout to dexter. No proper coloration.

Source: Wappenbuch der Arlberg-Bruderschaft.

Artist: Vigil Raber. (Page 228.) Adapted by Owen Tegg.

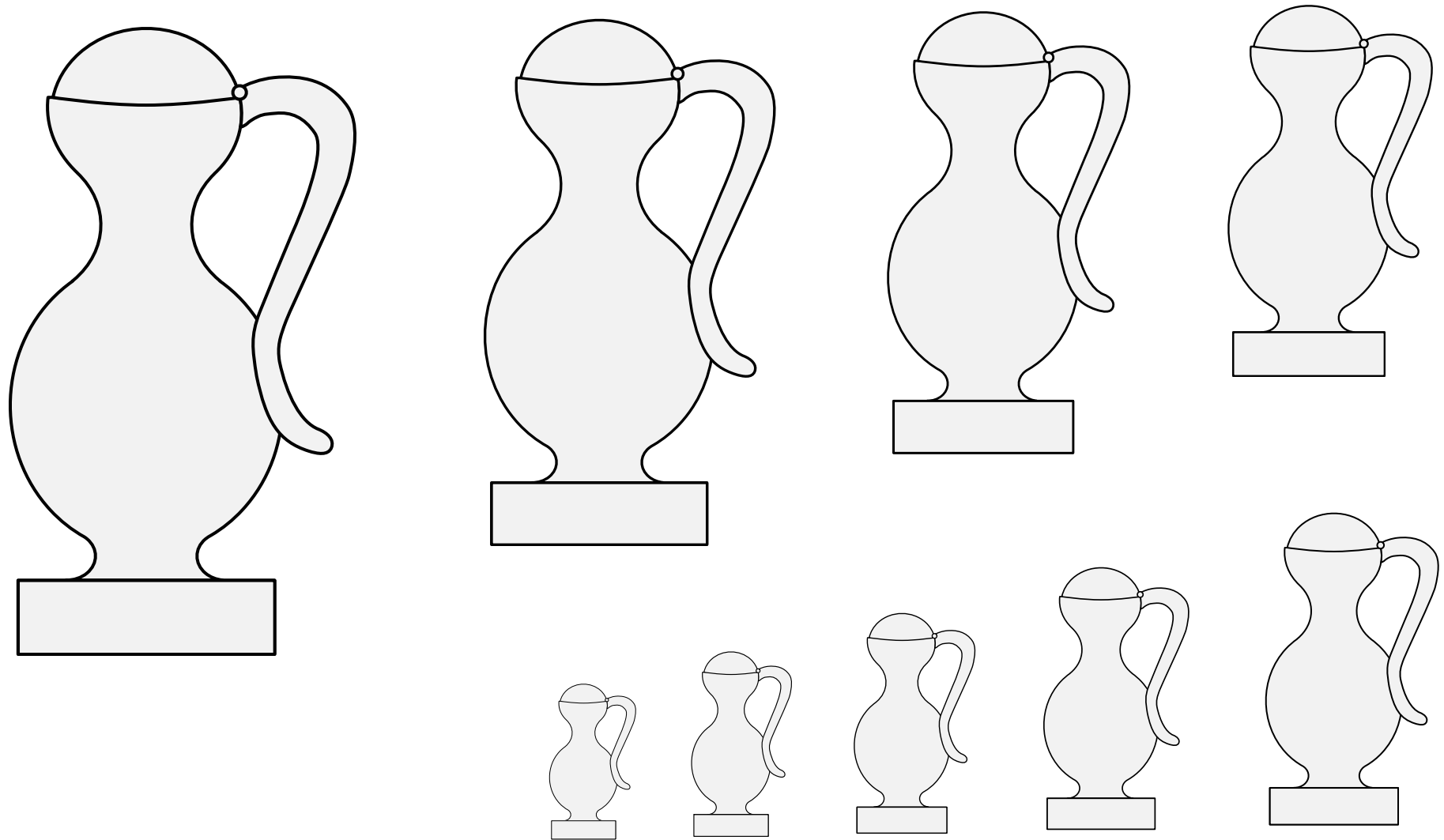

A container for carrying and pouring water.

Default orientation: palewise, spout to dexter. No proper coloration.

Source: KBR MS II 6616. (Folio 39v.) Artist unknown.
(Arms of Philips van Aertrycke.)

Pitcher, Covered (2) 14.132

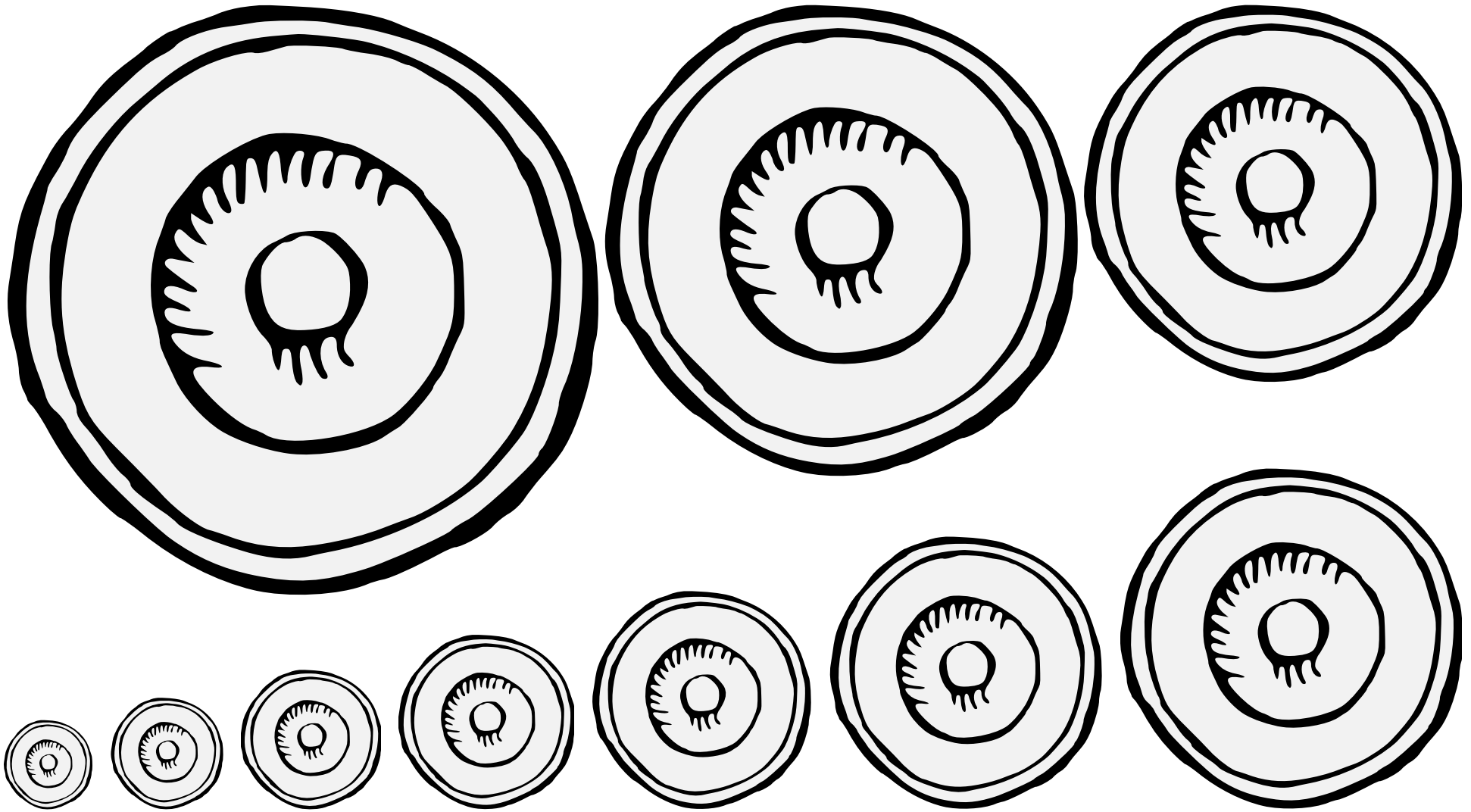

A flat serving or eating dish.

Default orientation: affronty or three-quarter view. No proper coloration.

Source: Funeral Arms and Commissions for Visitations. Artist unknown. (Folio 125v.)

Platter 14.133

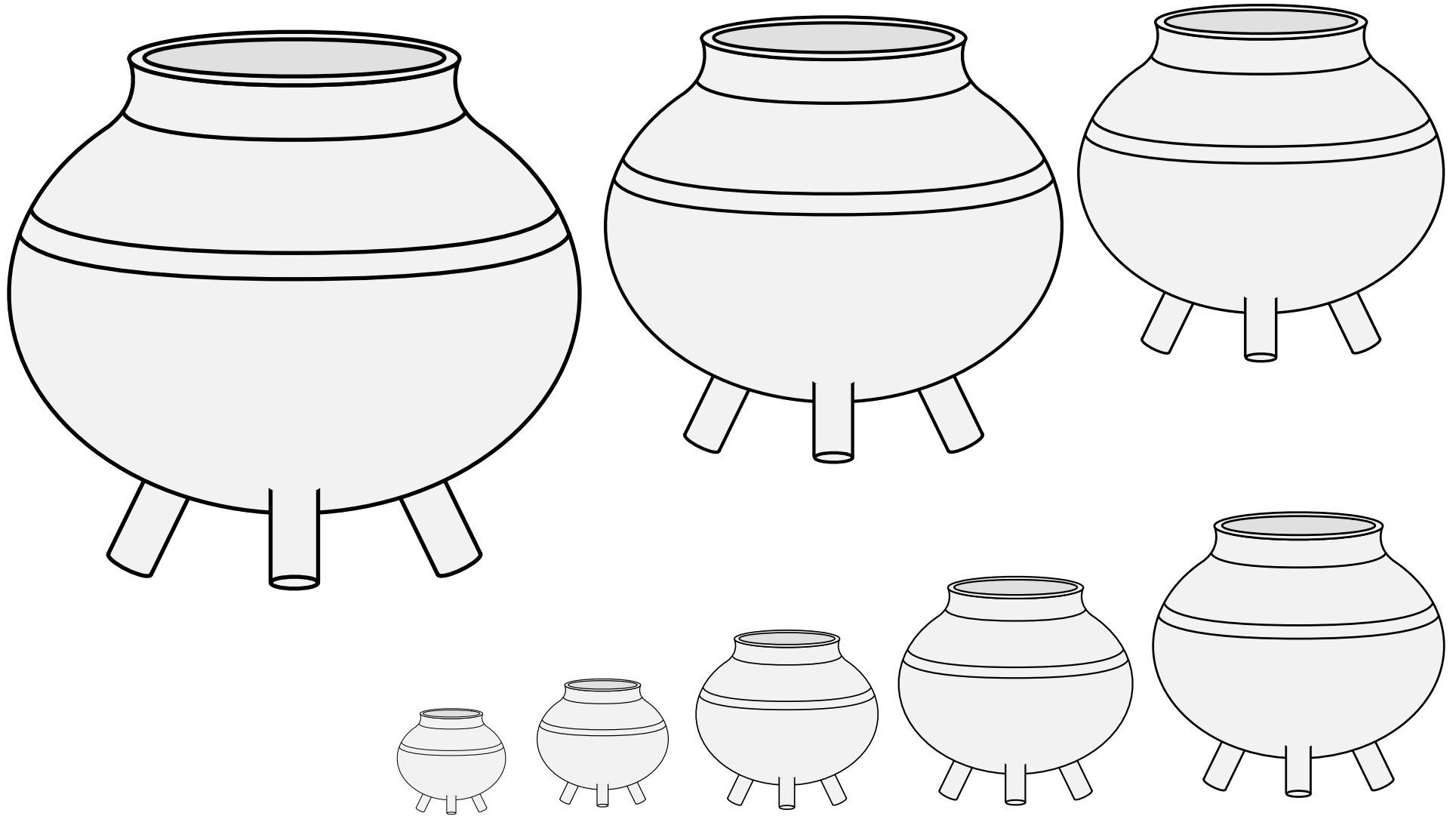

A round cooking pot with squat feet to hold it steady in a fire.
Default orientation: upright. No proper coloration.
Adapted from Badische Landesbibliothek band 13. (Page 175.)

Pot, Footed (1) 14.134

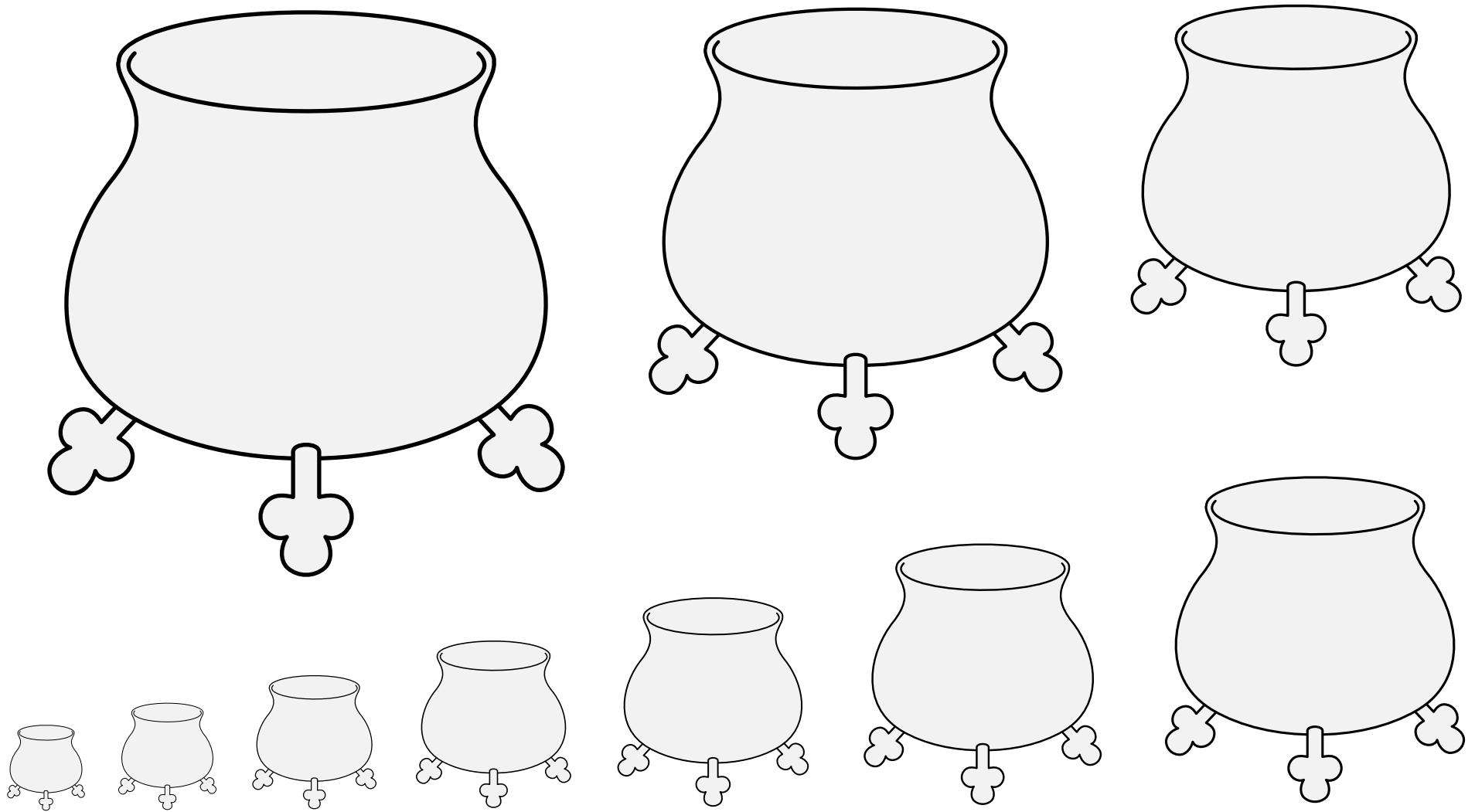

A round cooking pot with squat feet to hold it steady in a fire.
Default orientation: upright. No proper coloration.

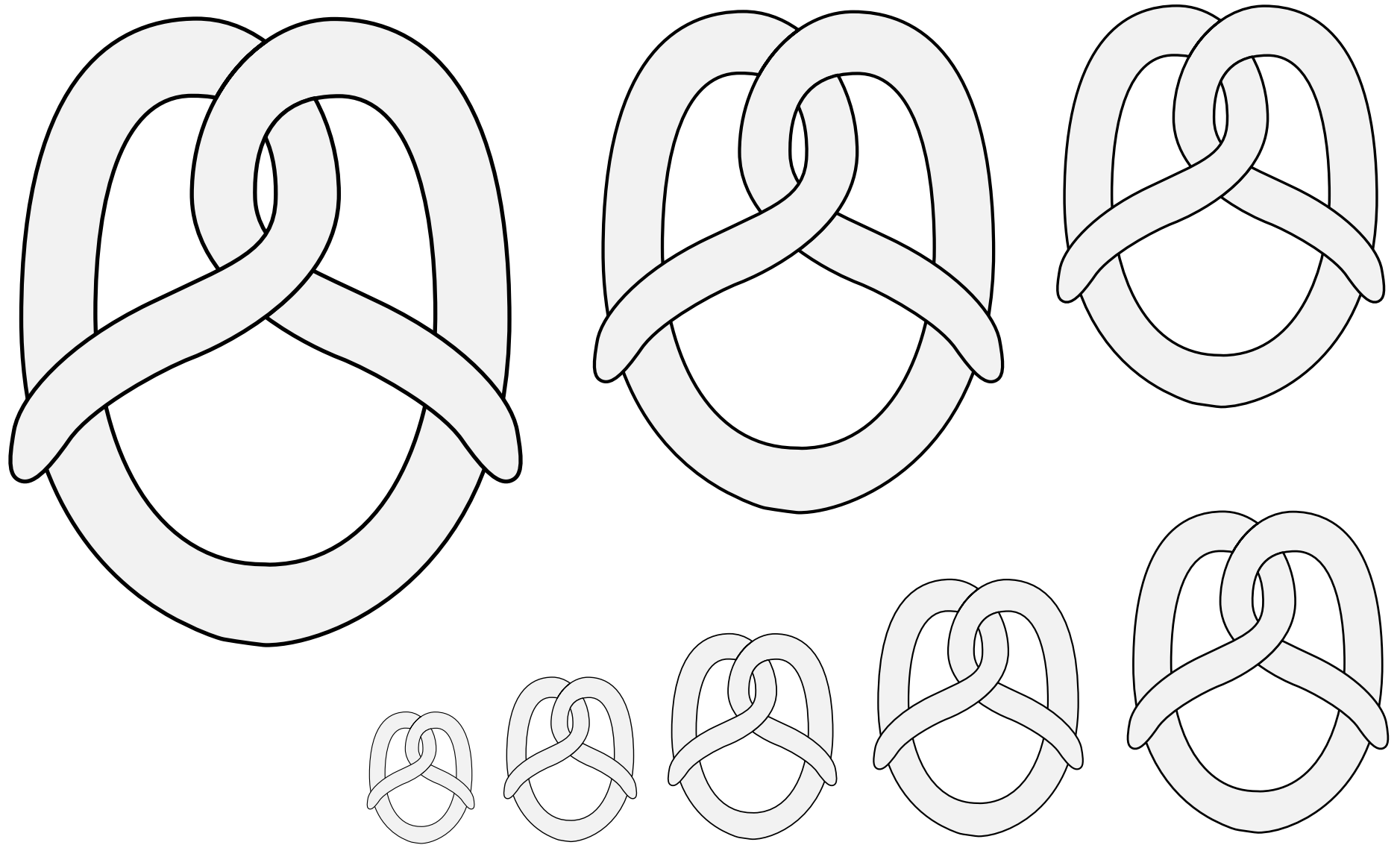

A knotted bread stick.

No default orientation. Proper coloration: brown.

Source: Cod. Sang. 543. Artist: Kaspar Härtli. (Folio 1r.)

Pretzel (1) 14.136

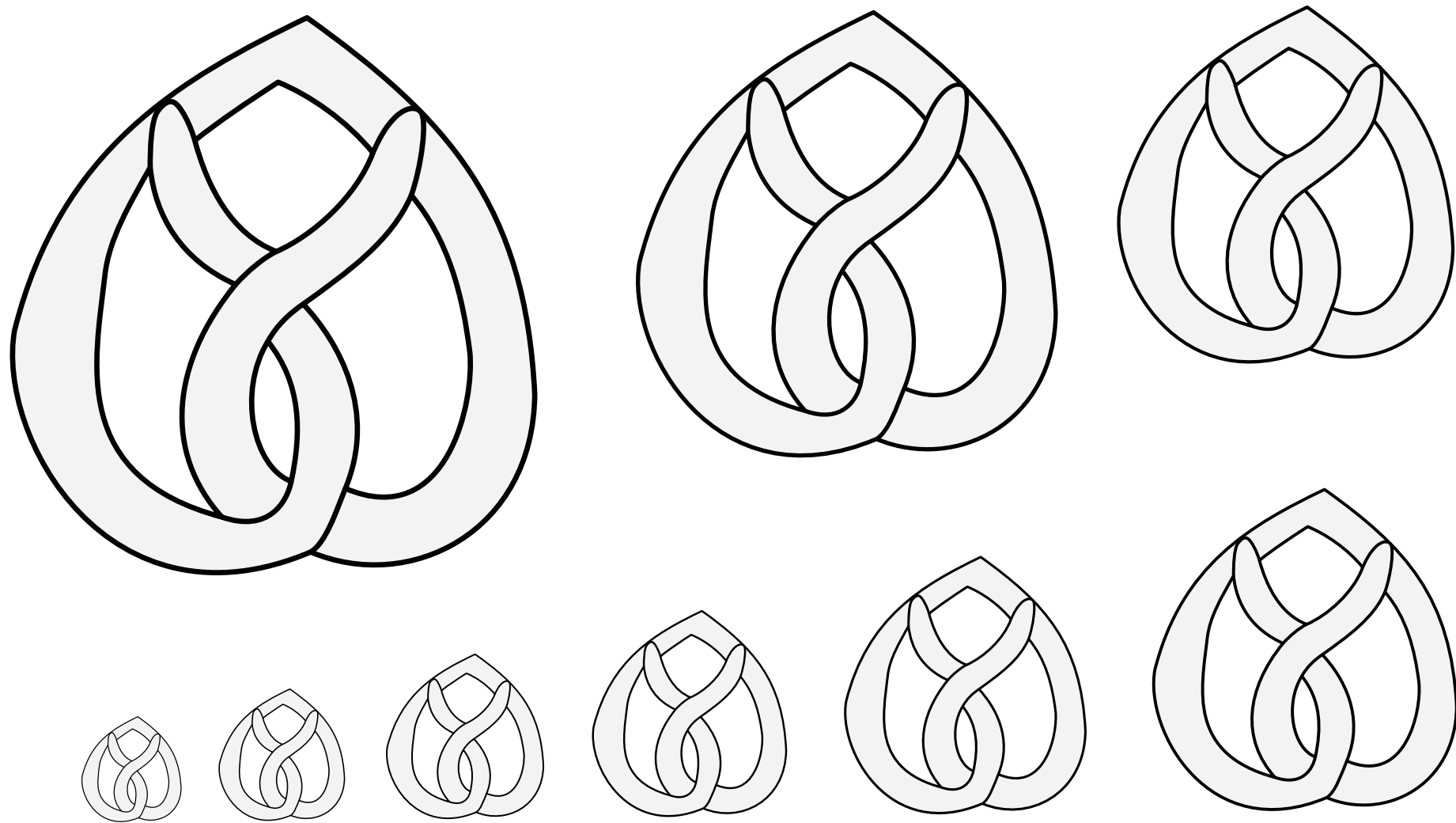

A knotted bread stick.

No default orientation. Proper coloration: brown.

Source: Austrian State Archives. (AT-OeStA_AVA_Adel_RAA_326.33, 1602.)

Artist unknown. Adapted by Iago ab Adam.

Pretzel (2) 14.137

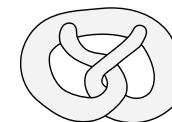
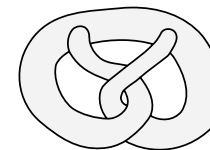
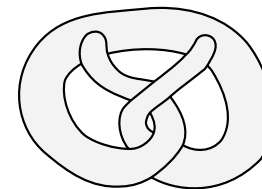
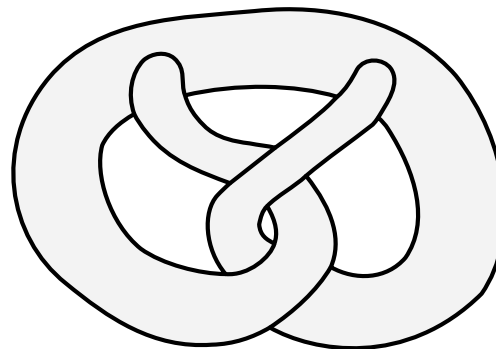
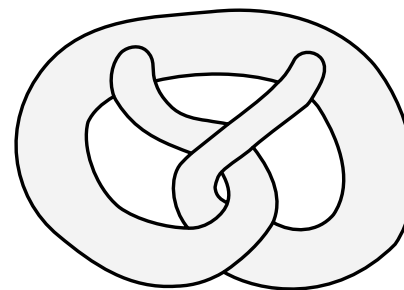
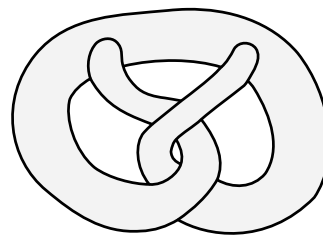
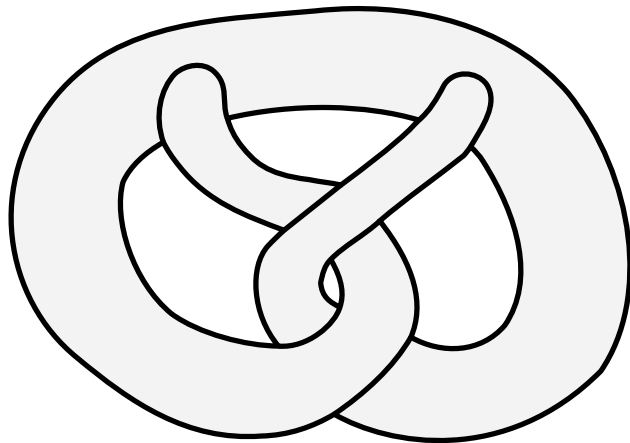
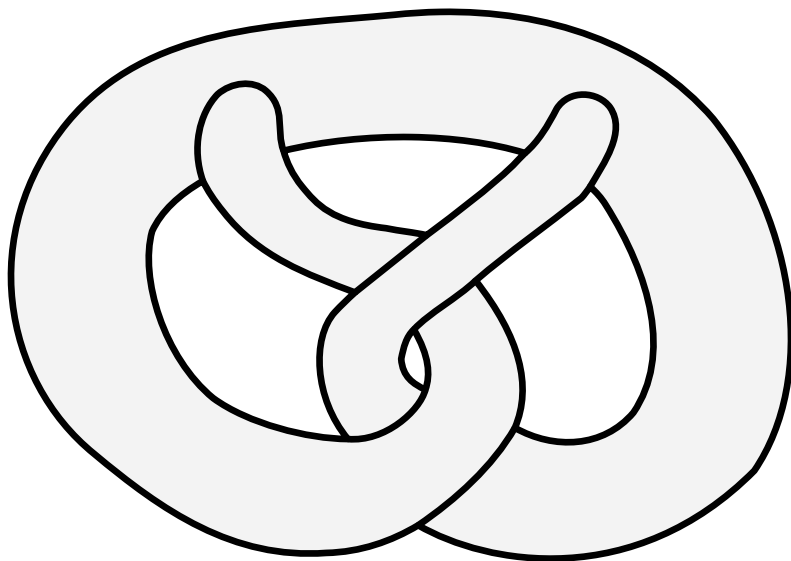

A knotted bread stick.

No default orientation. Proper coloration: brown.

Source: Nekrolog des Bamberger Franziskanerklosters.
(Staatsbibliothek Bamberg HV.Msc.302, f. 5v.)

Artist unknown. Adapted by Iago ab Adam.

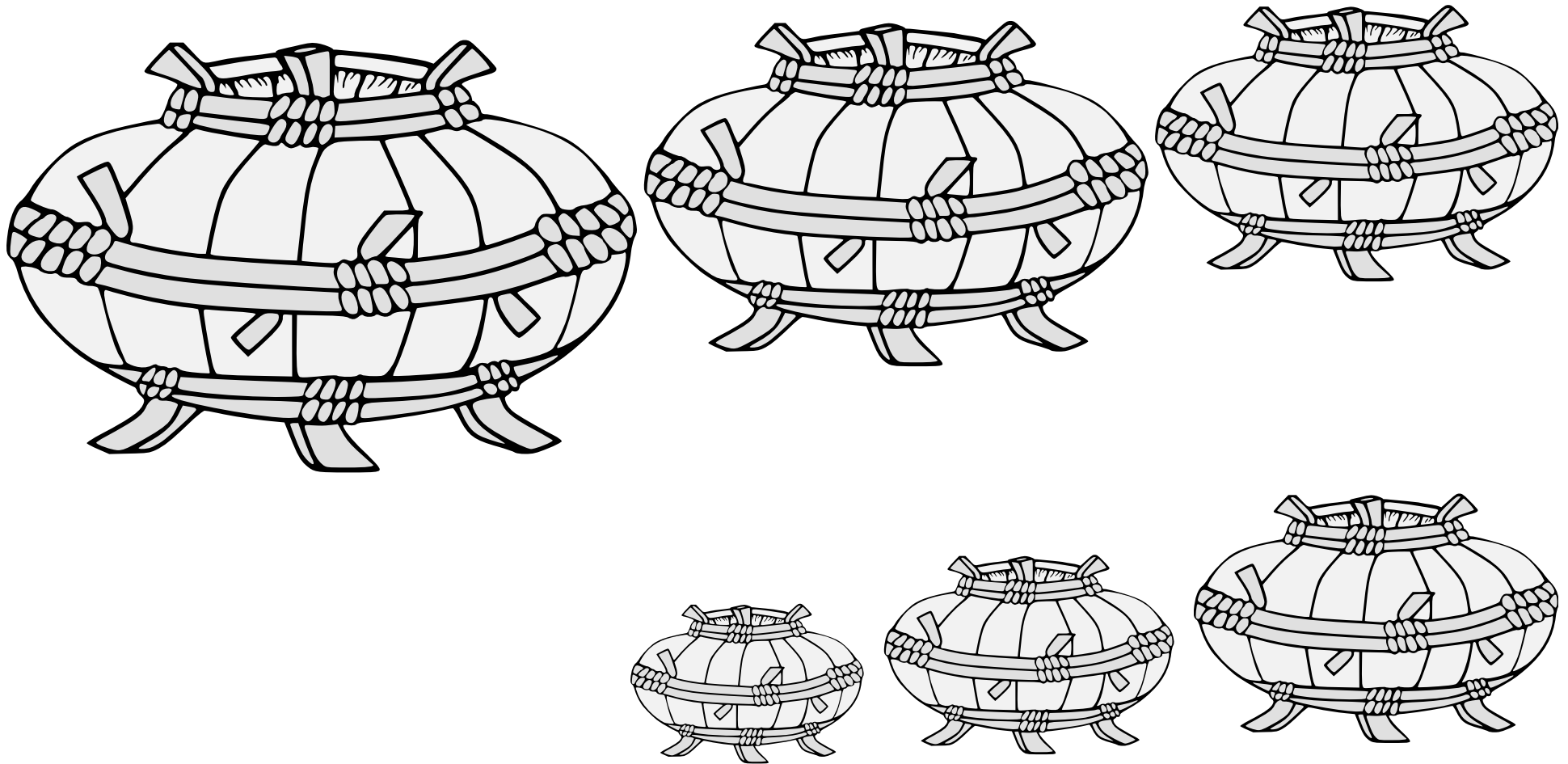

A container used to transport salt.

Default orientation: opening to top. No proper coloration.

Source: Wernigerode Armorial. Artist unknown.

Adapted by Jessimond of Emerickeskepe.
(Arms of Pötschner, folio 209v.)

Salt Barrel (1) 14.139

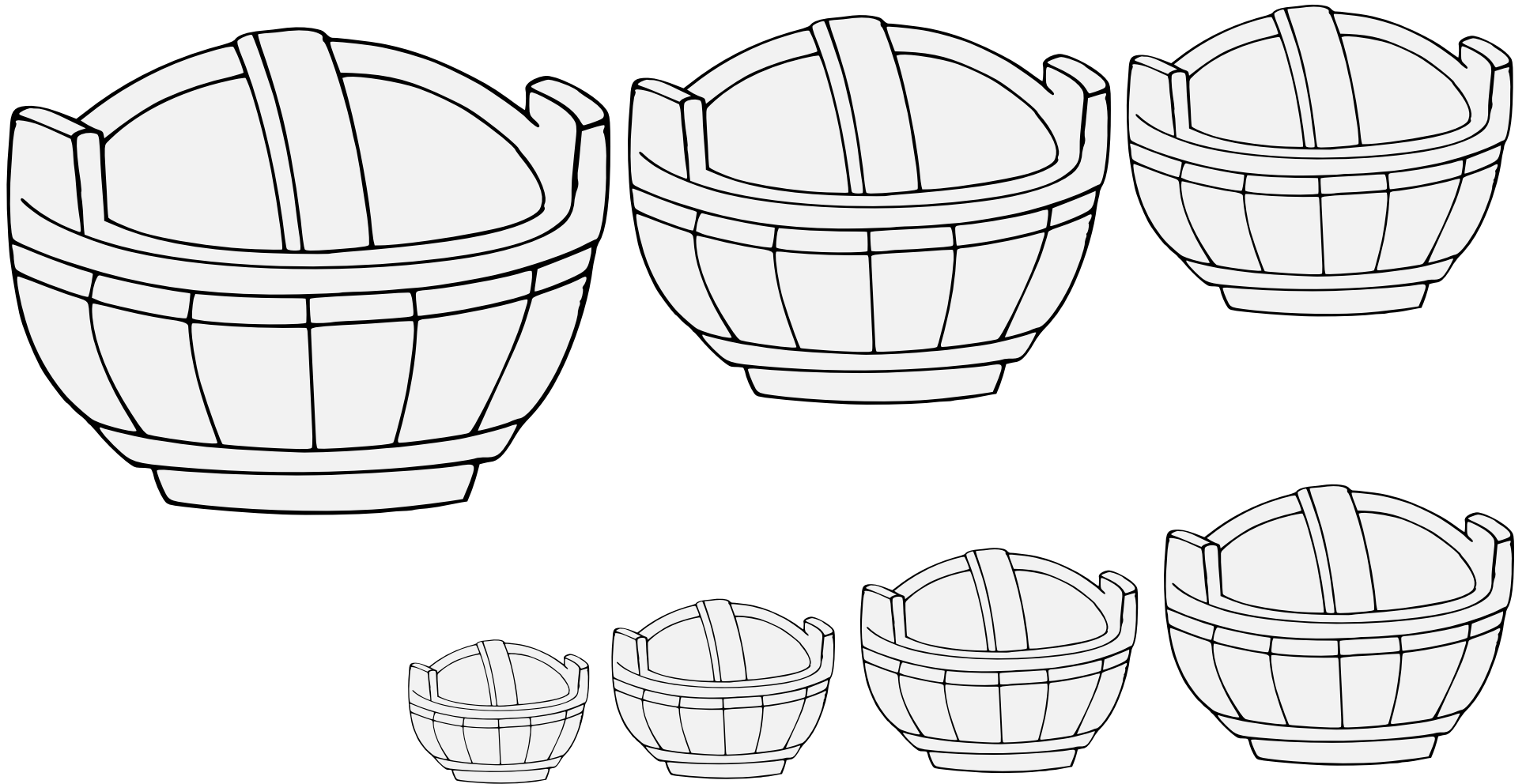

A container used to transport salt.

Default orientation: opening to top. No proper coloration.

Source: Wappenbuch der Arlberg-Bruderschaft.
Artist: Vigil Raber. (Page 402, arms of Kuchler.)

Salt Barrel (2) • 14.140

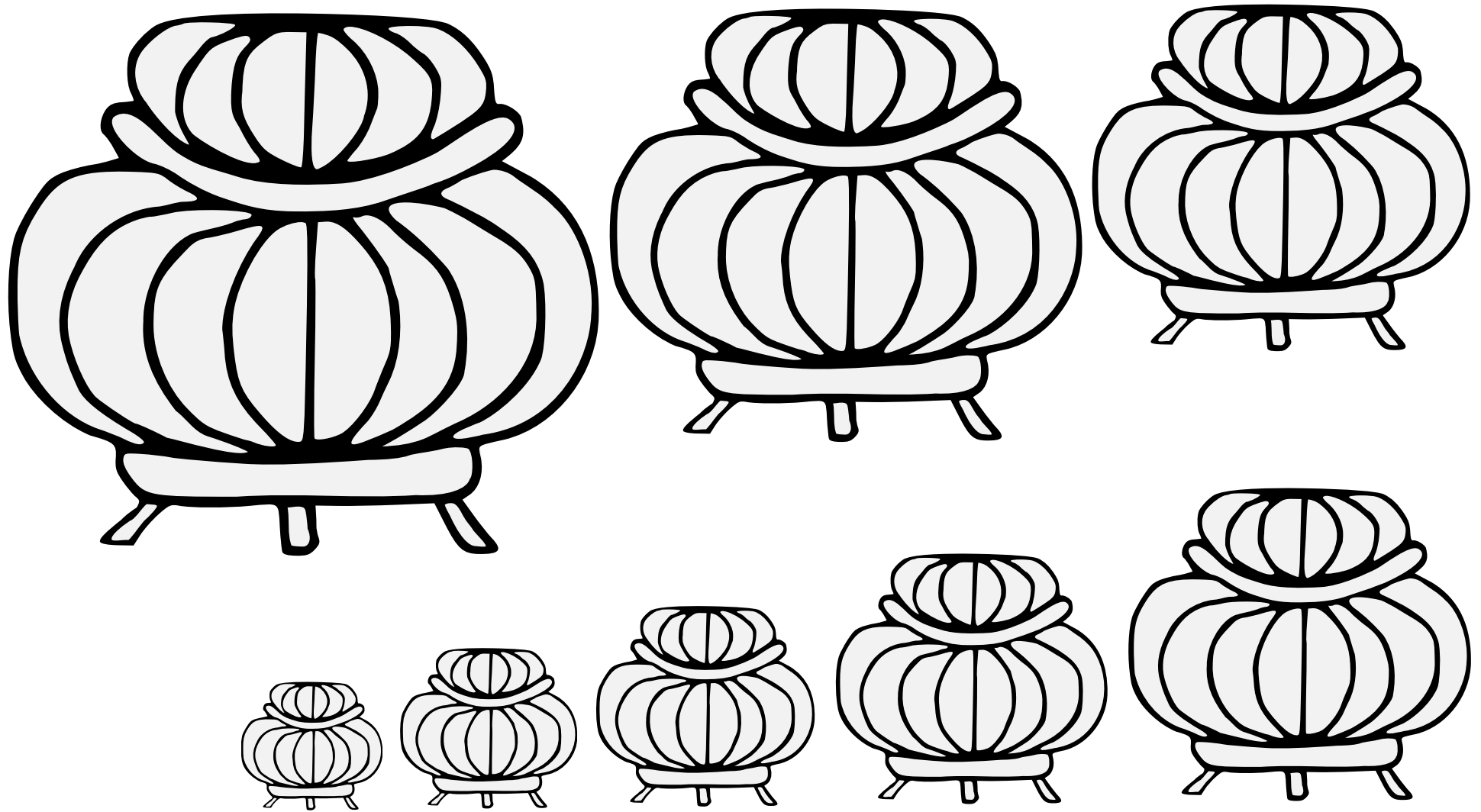

A container used to transport salt.

Default orientation: opening to top. No proper coloration.

Adapted from an image of the arms of Pötschner in a 1502 watermark.

Adapted by Iago ab Adam.

Salt Barrel (3) 14.141

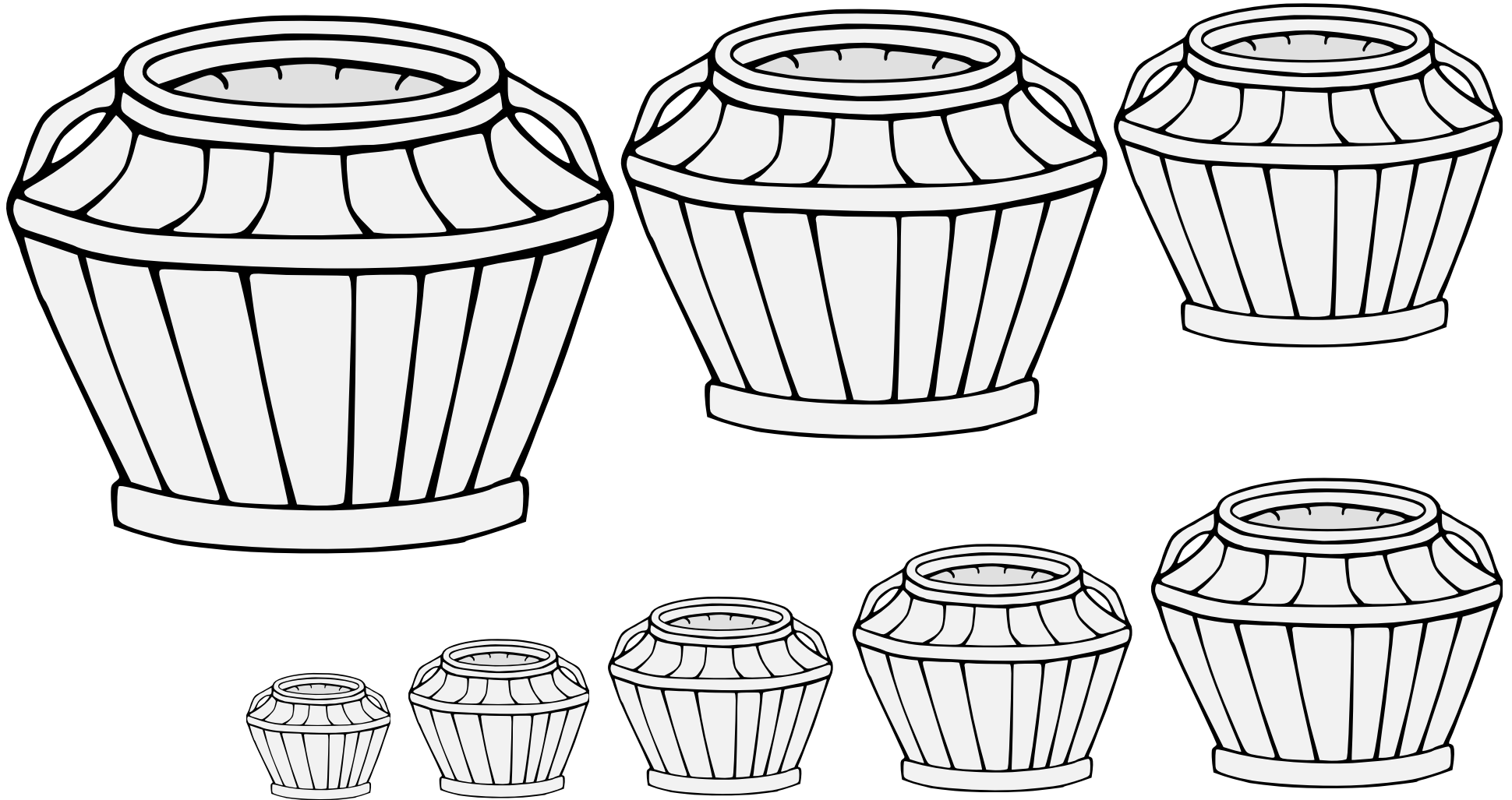

A container used to transport salt.

Default orientation: opening to top. No proper coloration.

Source: Wappenbuch Fol 222. Artist unknown. (Arms of Saltzman.)

Adapted by Jessimond of Emerickeskepe.

Salt Barrel (4) 14.142

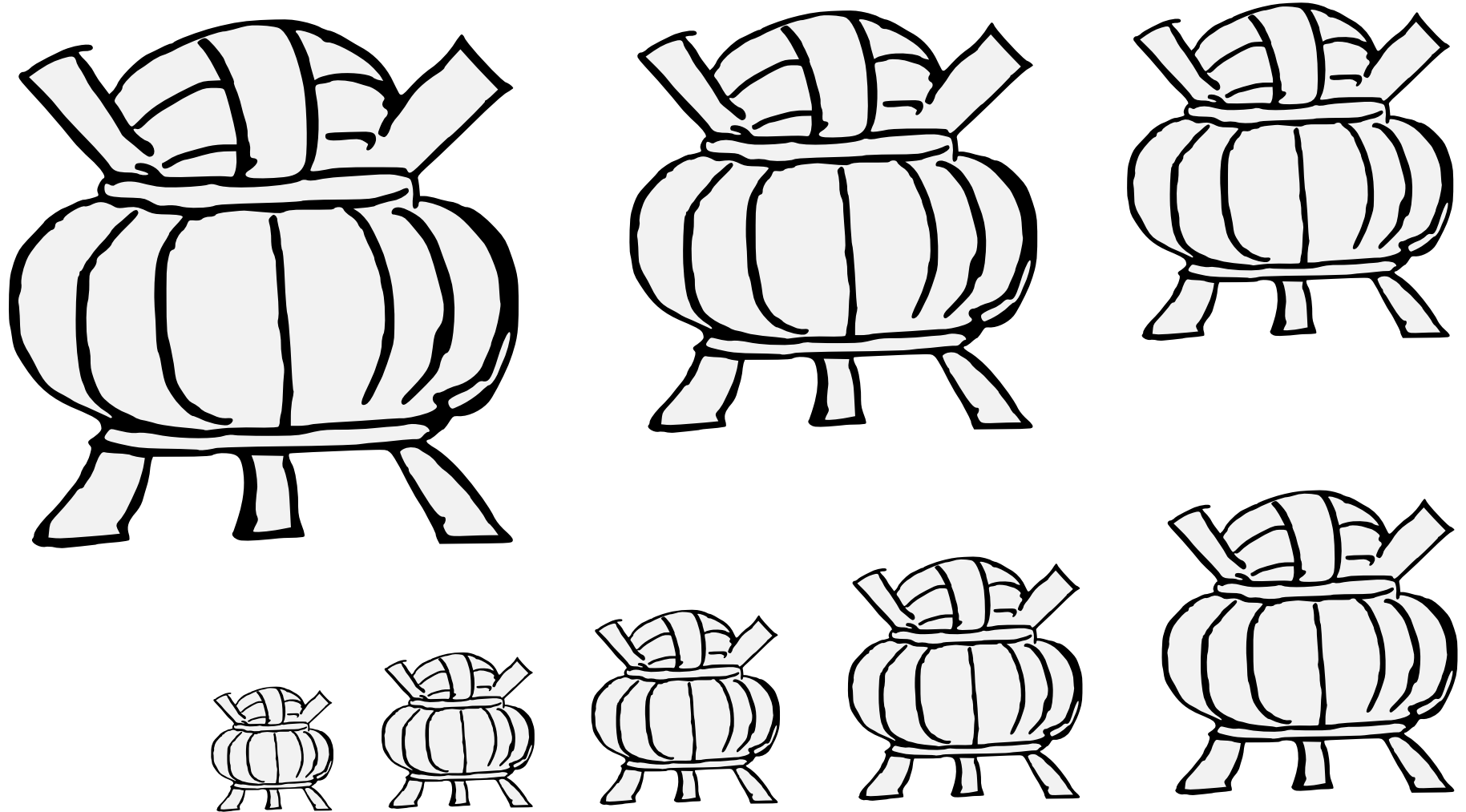

A container used to transport salt.

Default orientation: opening to top. No proper coloration.

Source: Hofkleiderbuch des Herzogs Wilhelm IV und Albrecht V.
Adapted by Iago ab Adam.

Salt Barrel (5) • 14.143

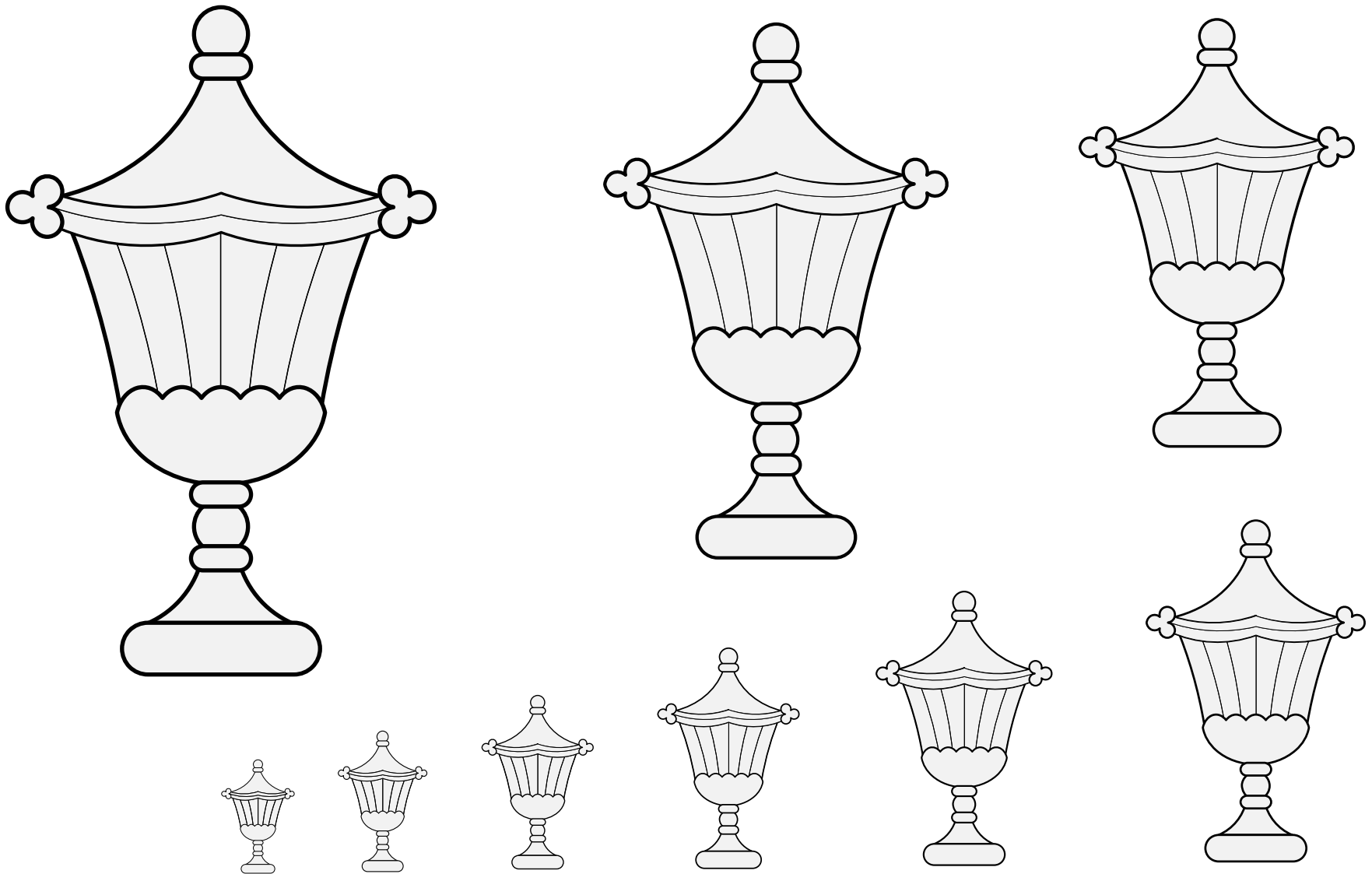

A container for dispensing salt at the dining table.

Default orientation: palewise. No proper coloration.

Source: Viking Answer Lady SVG Images For Heraldry.

Artist: Gunnvôr silfrahárr.

Saltcellar, Covered 14.144

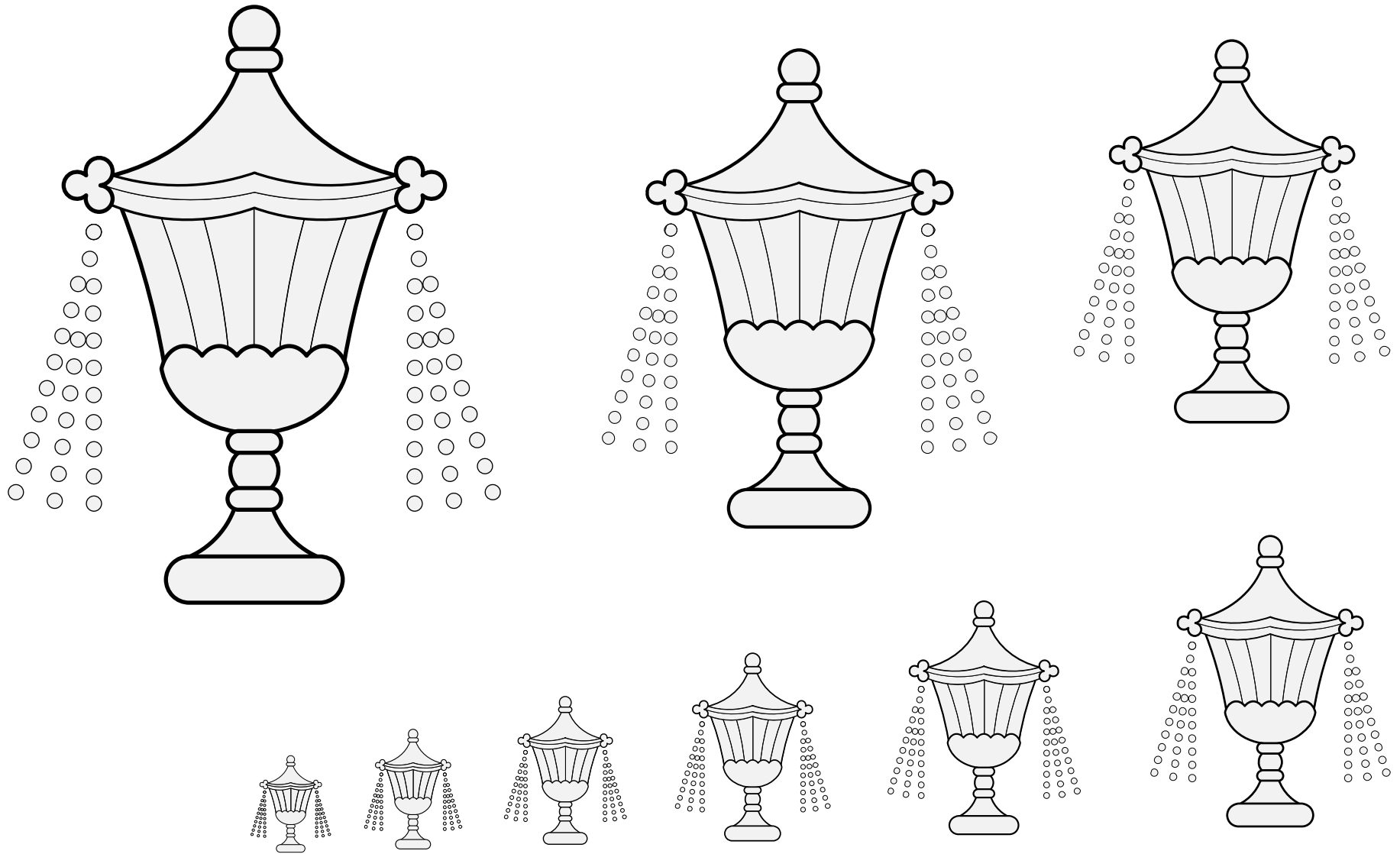

A container for dispensing salt at the dining table.
Default orientation: palewise. No proper coloration.
Source: Viking Answer Lady SVG Images For Heraldists. Artist: Gunnvör silfrhárr.

Saltcellar, Covered, Shedding Salt (1) 14.145

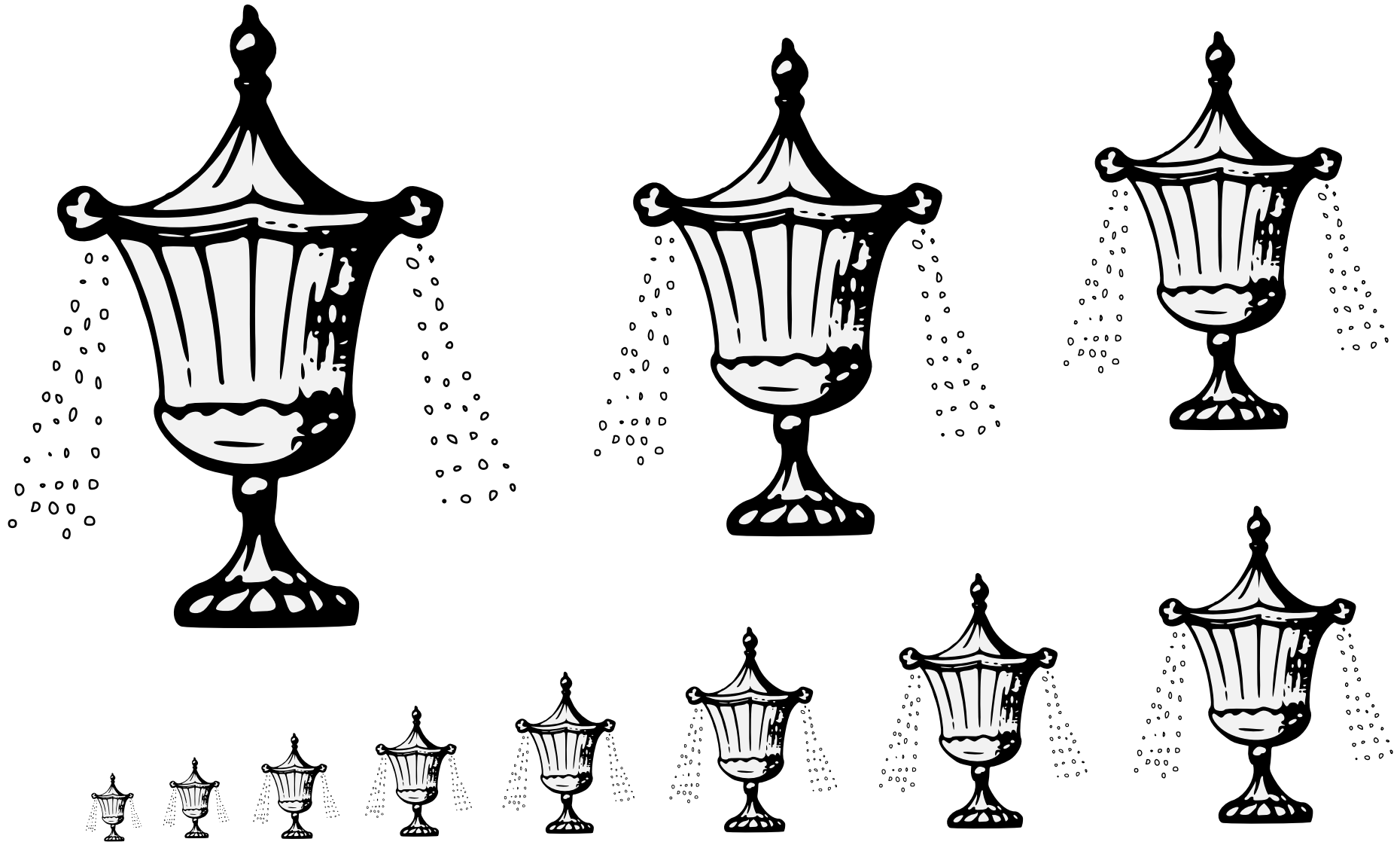

A covered serving container with salt spilling from its sides.

Default orientation: upright.

Source: A Glossary of Terms Used in Heraldry. Artist: James or Irene Parker.

Saltcellar, Covered, Shedding Salt (2) 14.146

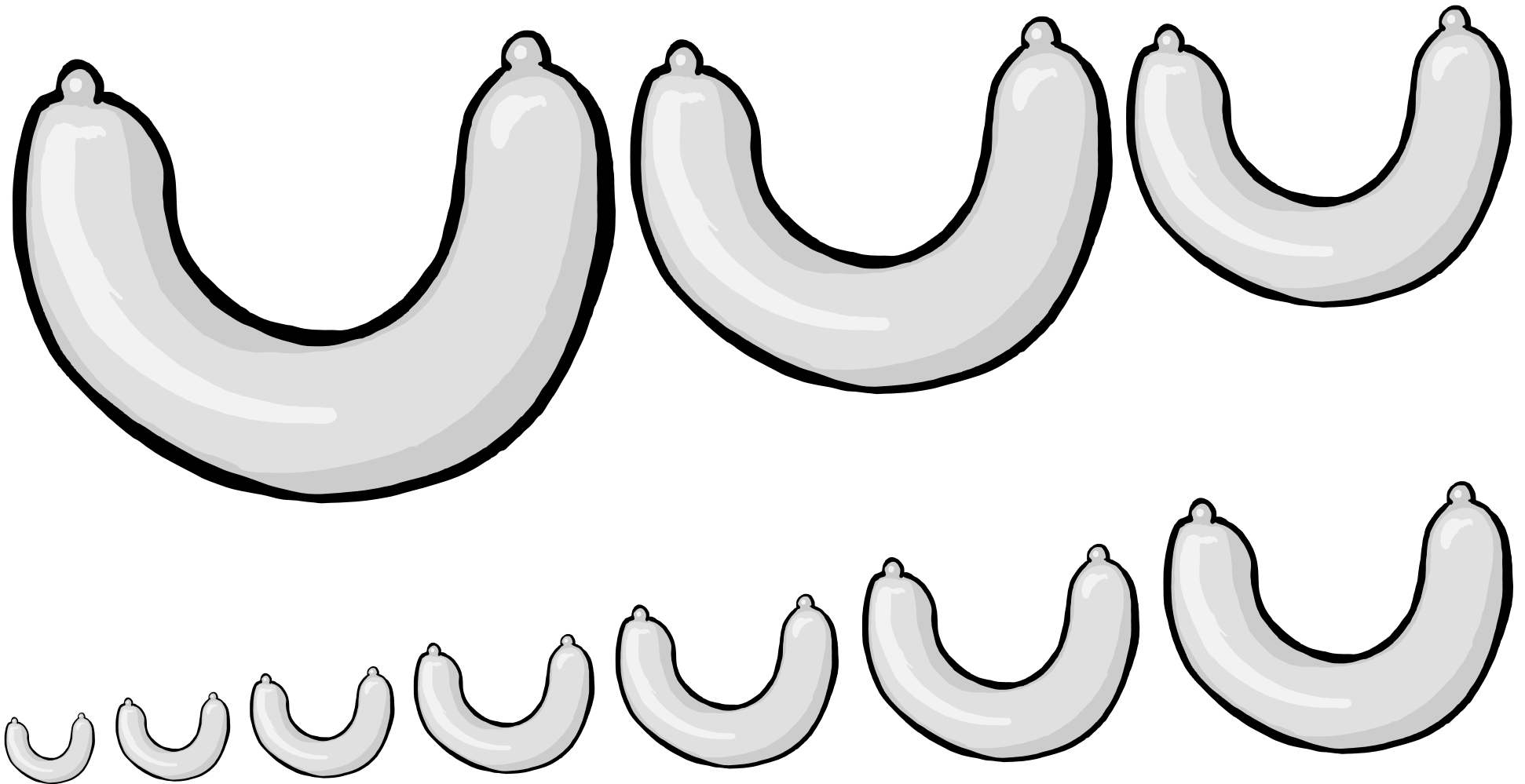

A tube of ground meat.

Default orientation in period seems to be crescent-wise. No proper coloration.

Source: Manchester University Library Latin MS 28. Artist unknown.
(Page 114.) Adapted by Saewynn aet Cnolle.

Sausage 14.147

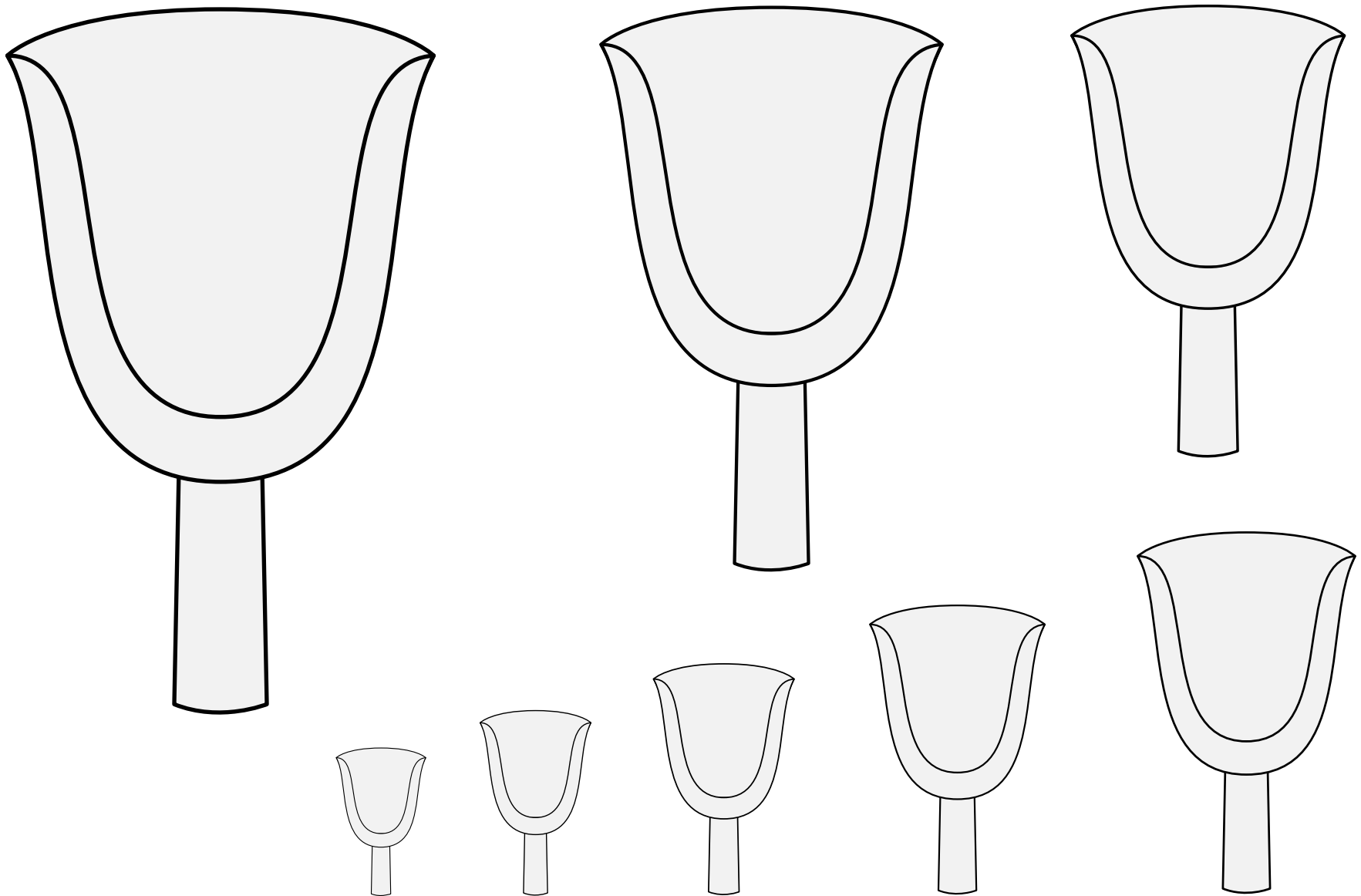

A hand tool such as might be used to transfer grains from a sack.
Source: Neustifter Wappenbuch. Artist: Vigil Raber.

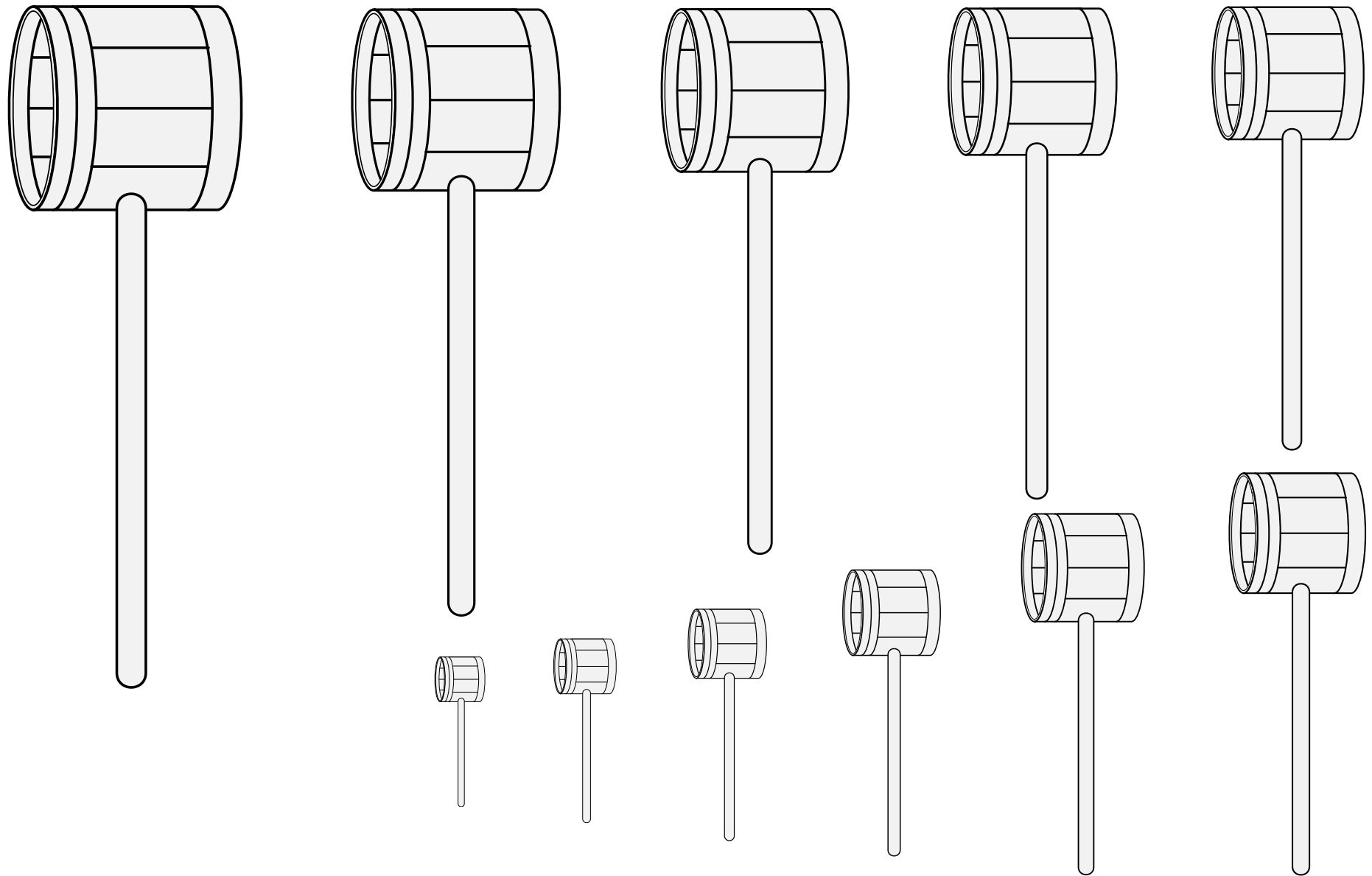

A type of ladle used by brewers, consisting of a tiny bucket on the end of a long handle.

Default orientation: bucket to chief, opening to dexter. Proper coloration: brown wood.

Source: Wappenbuch der Arlberg-Bruderschaft.

Artist: Vigil Raber. (Folio 42r.)

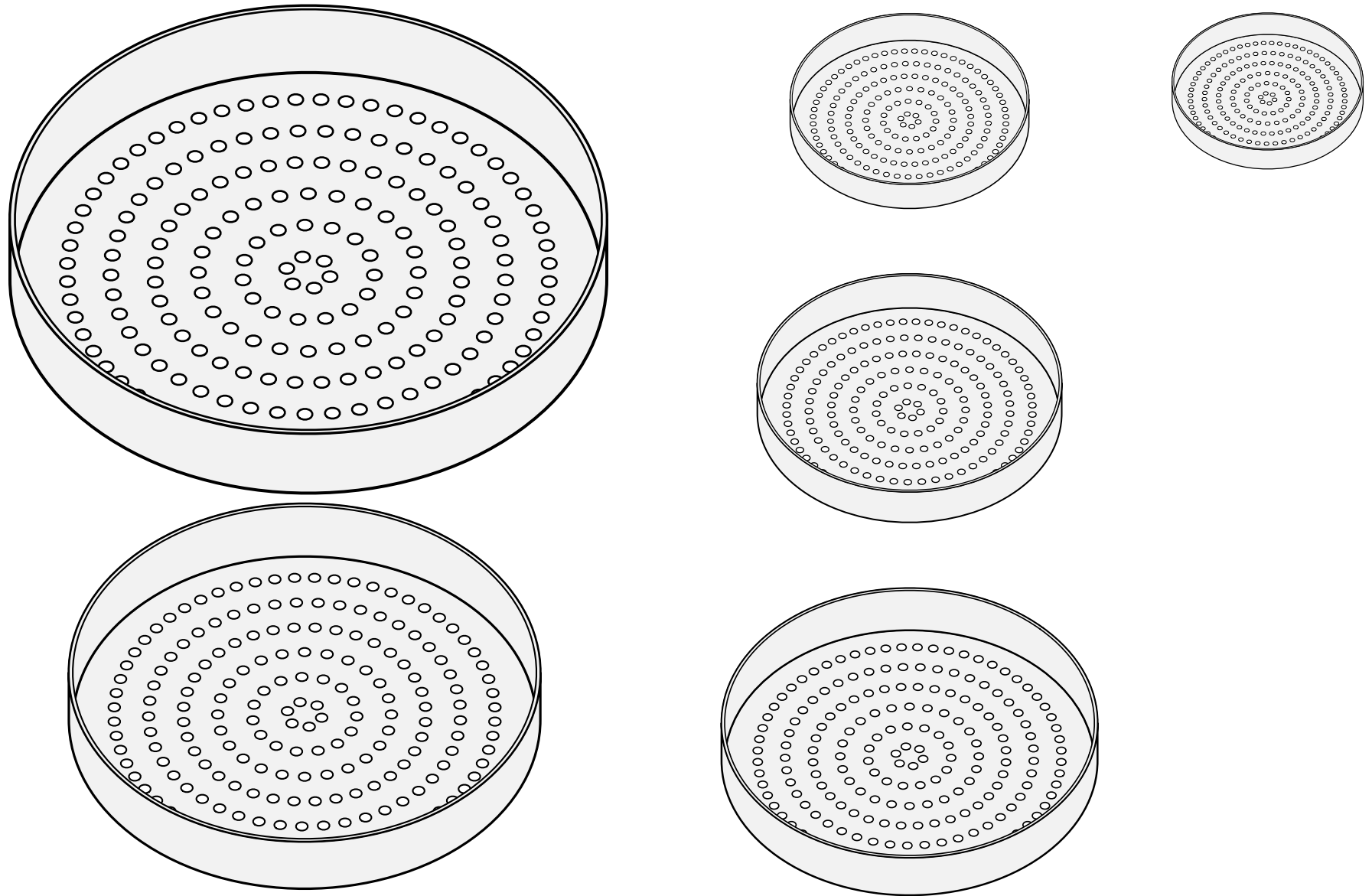

A tool for separating fine and coarse grains.

Source: *Insignia Venetorum Nobilium II*. Artist unknown.
(From the arms of *Chrinelli*, folio 100.)

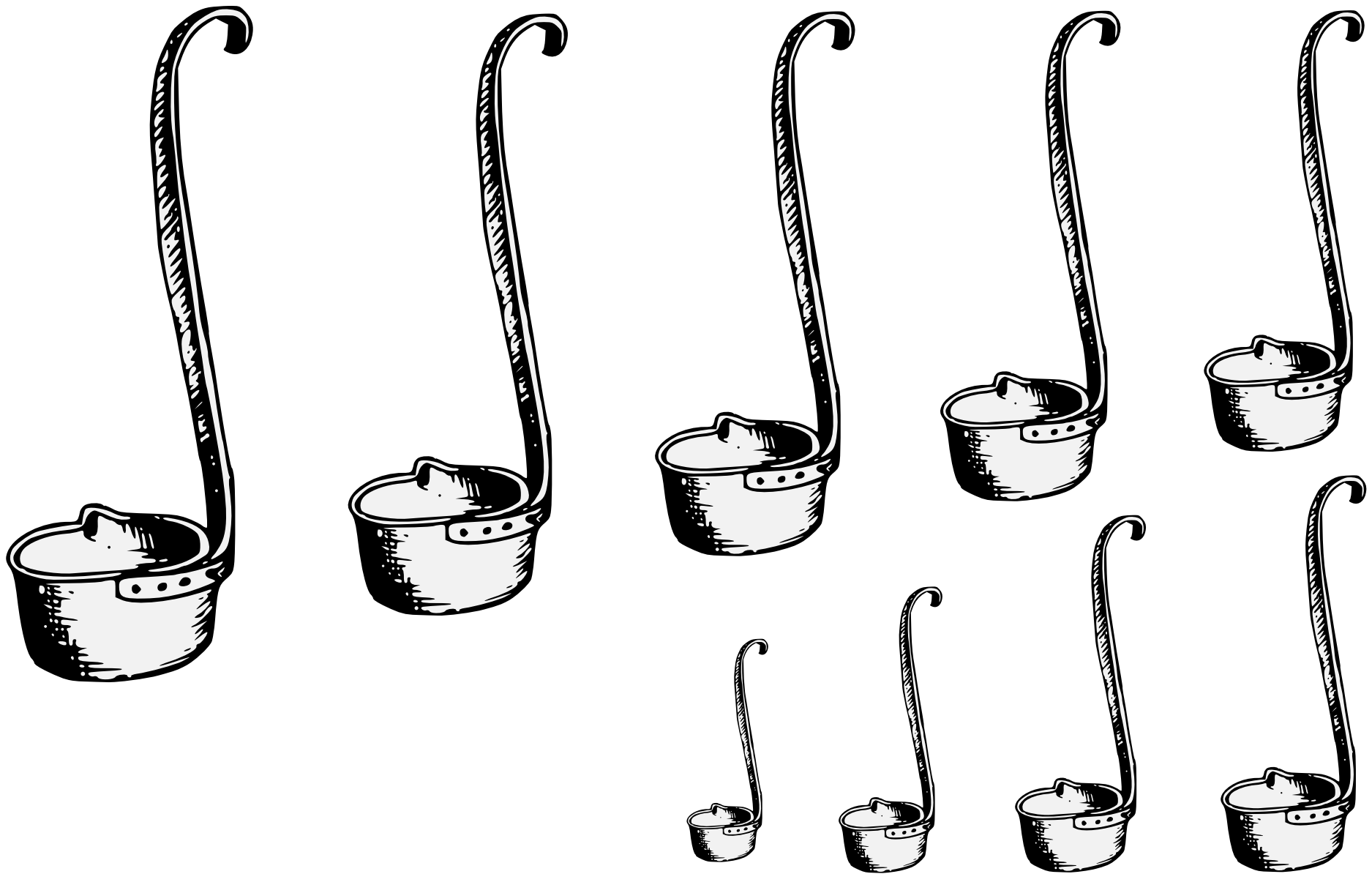

A utensil for skimming the fat off the surface of a soup.
Default orientation: palewise, handle to chief. No proper coloration.
Source: Opera Dell'arte Del Cucinare. Artist unknown. (Page 967.)

Skimmer 14.151

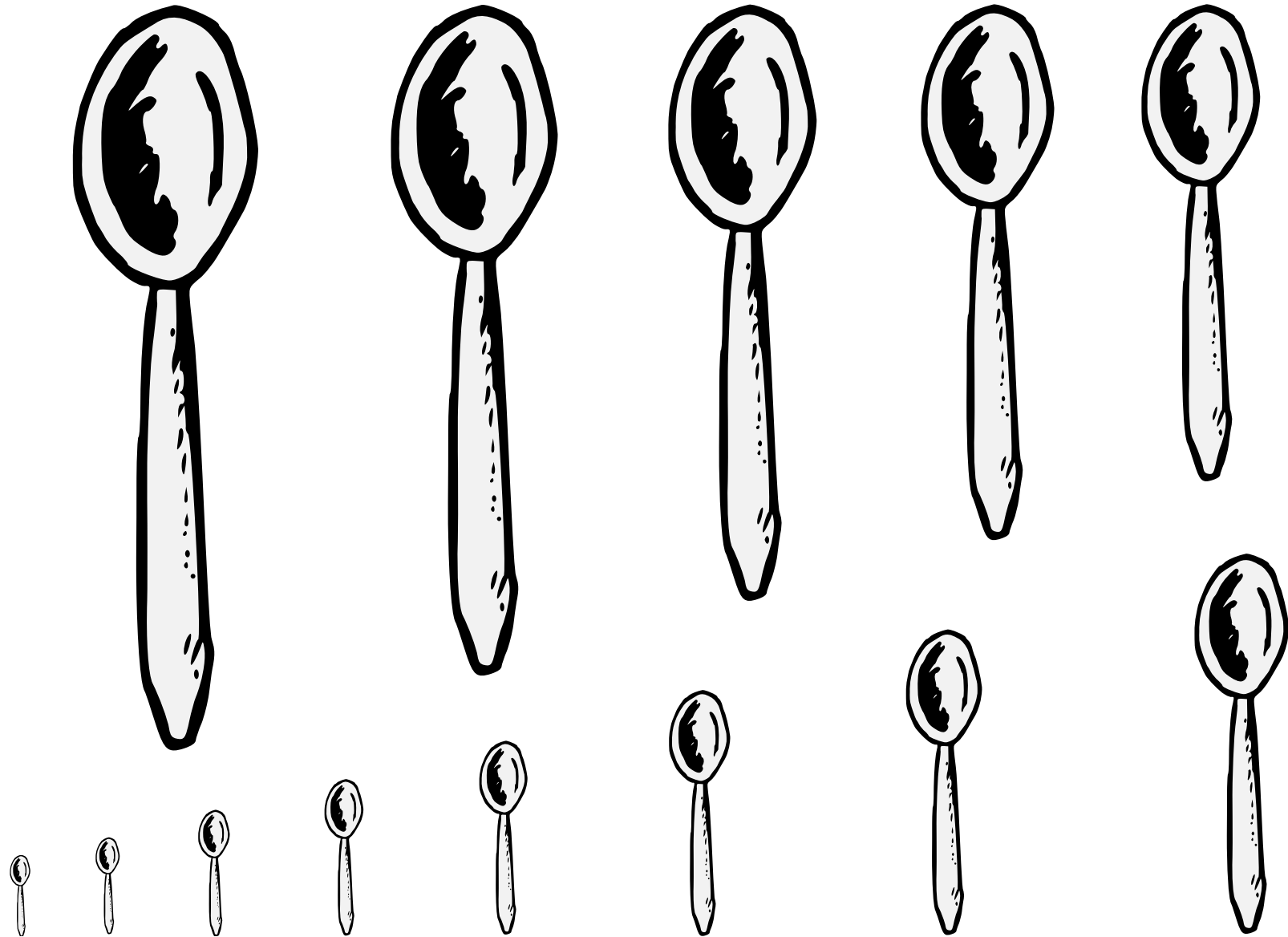

A utensil for eating or stirring food.

Default orientation: palewise, handle to base. No proper coloration.

Source: Pennsic Traceable Art. Artist unknown.

Spoon (1) 14.152

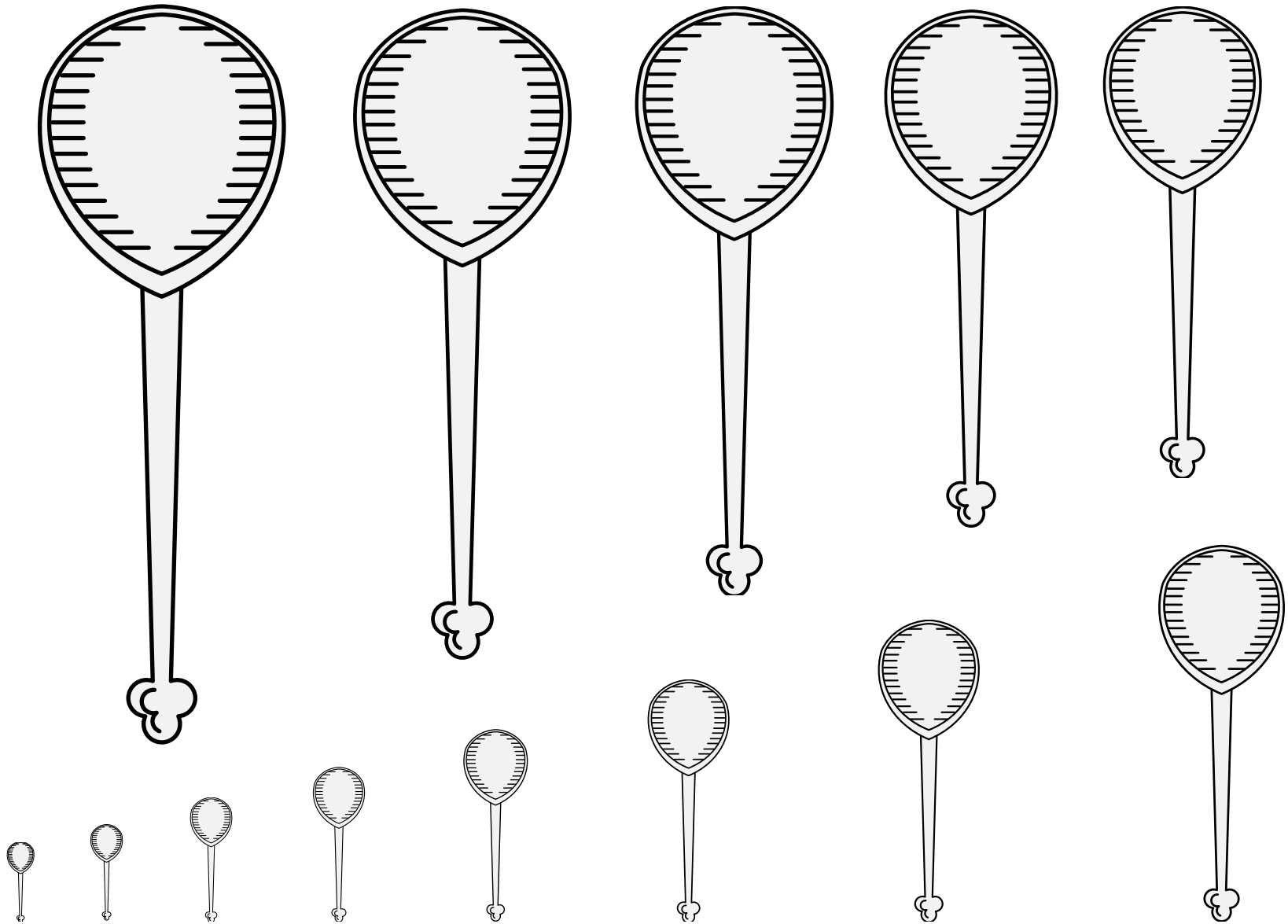

A utensil for eating or stirring food.

Default orientation: palewise, handle to base. No proper coloration.

Source: Viking Answer Lady SVG Images For Heraldists. Artist: Gunnvôr silfráhr.

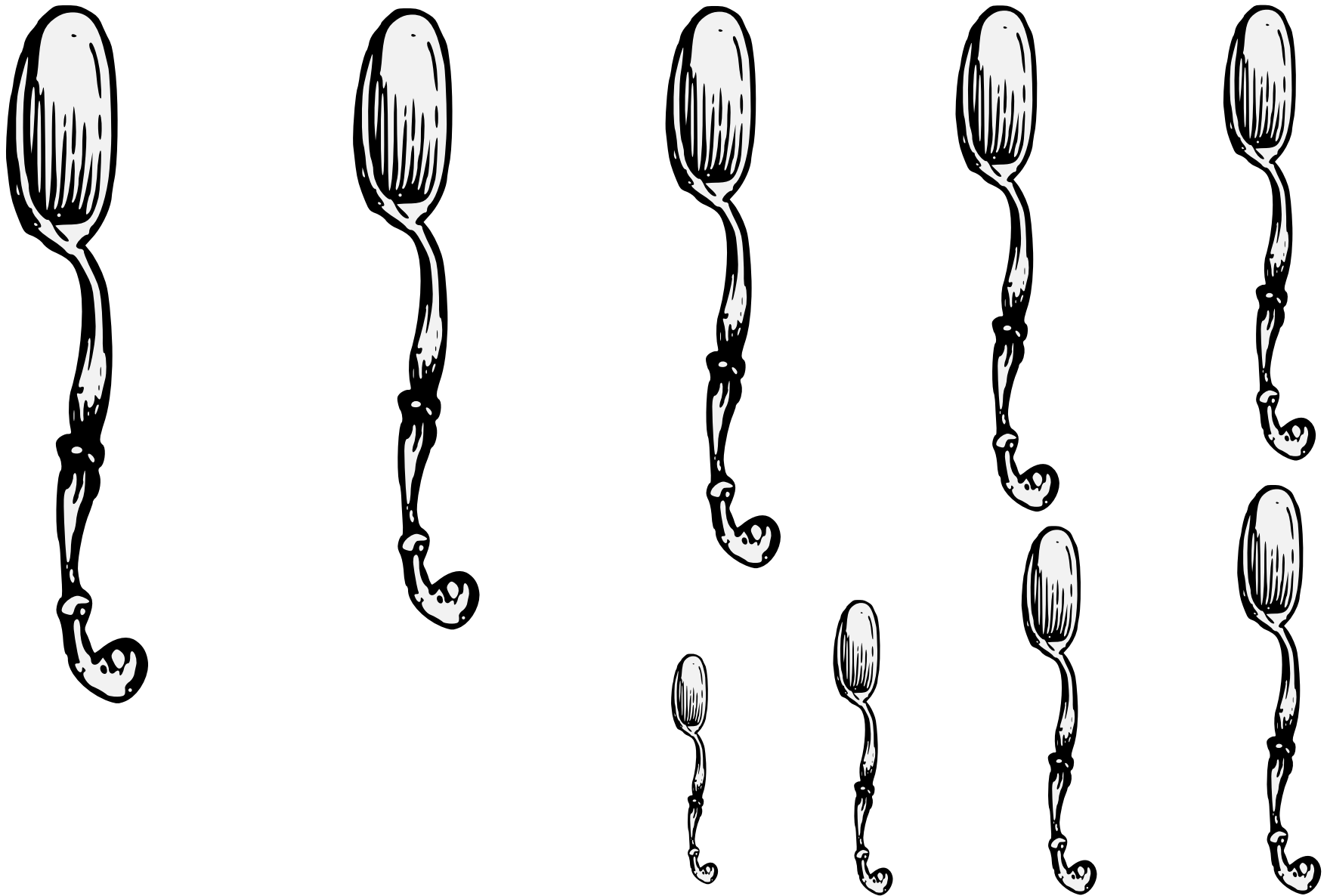

A utensil for eating or stirring food.

Default orientation: palewise, handle to base. No proper coloration.

Source: Opera Dell'arte Del Cucinare. Artist unknown. (Page 966.)

Spoon (3) 14.154

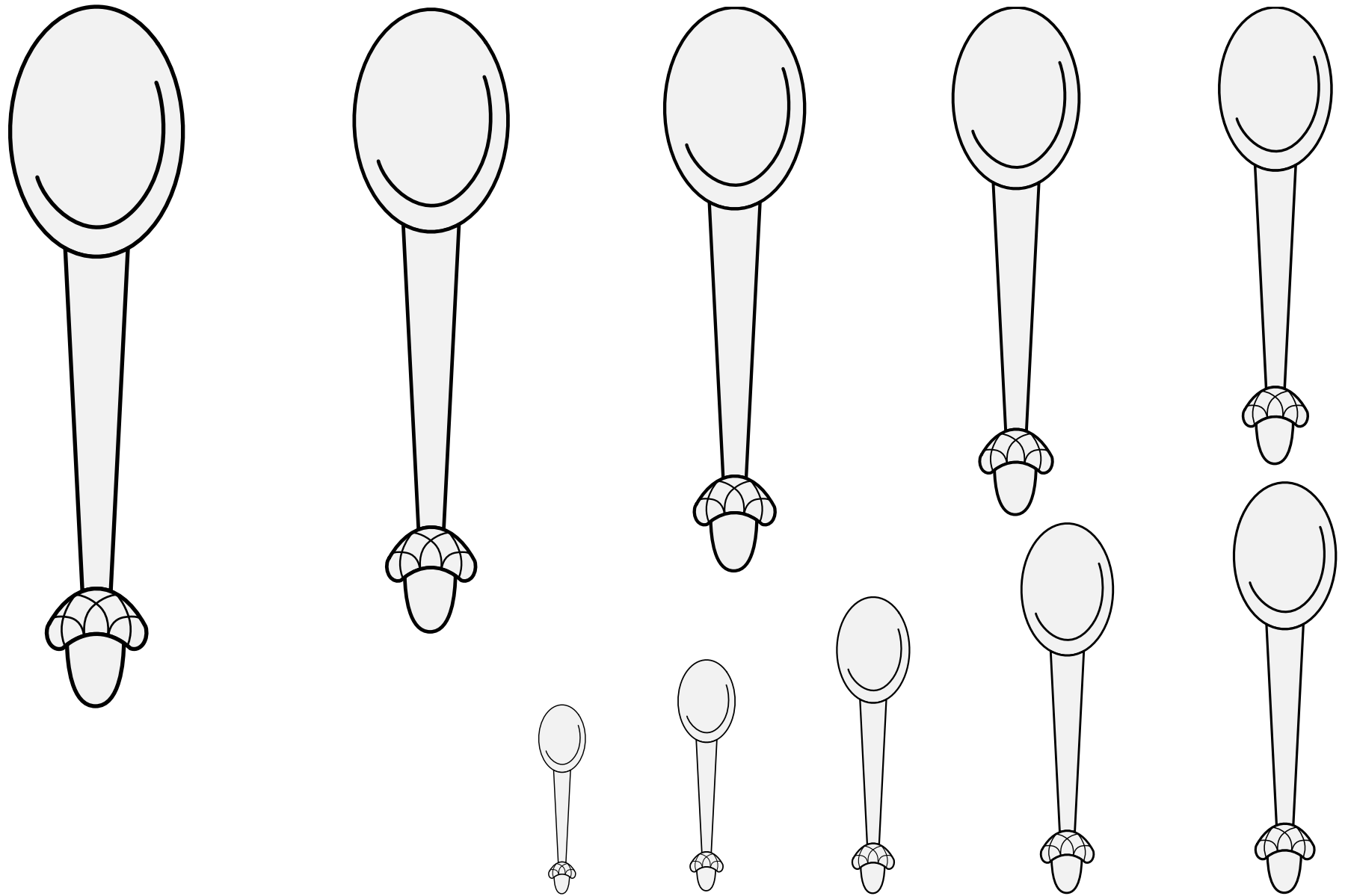

A utensil for eating or stirring food.

Default orientation: palewise, handle to base. No proper coloration.

Source: Two Tudor Books of Arms. Artist: Robert Cooke. (Page 77.)

Spoon (4) 14.155

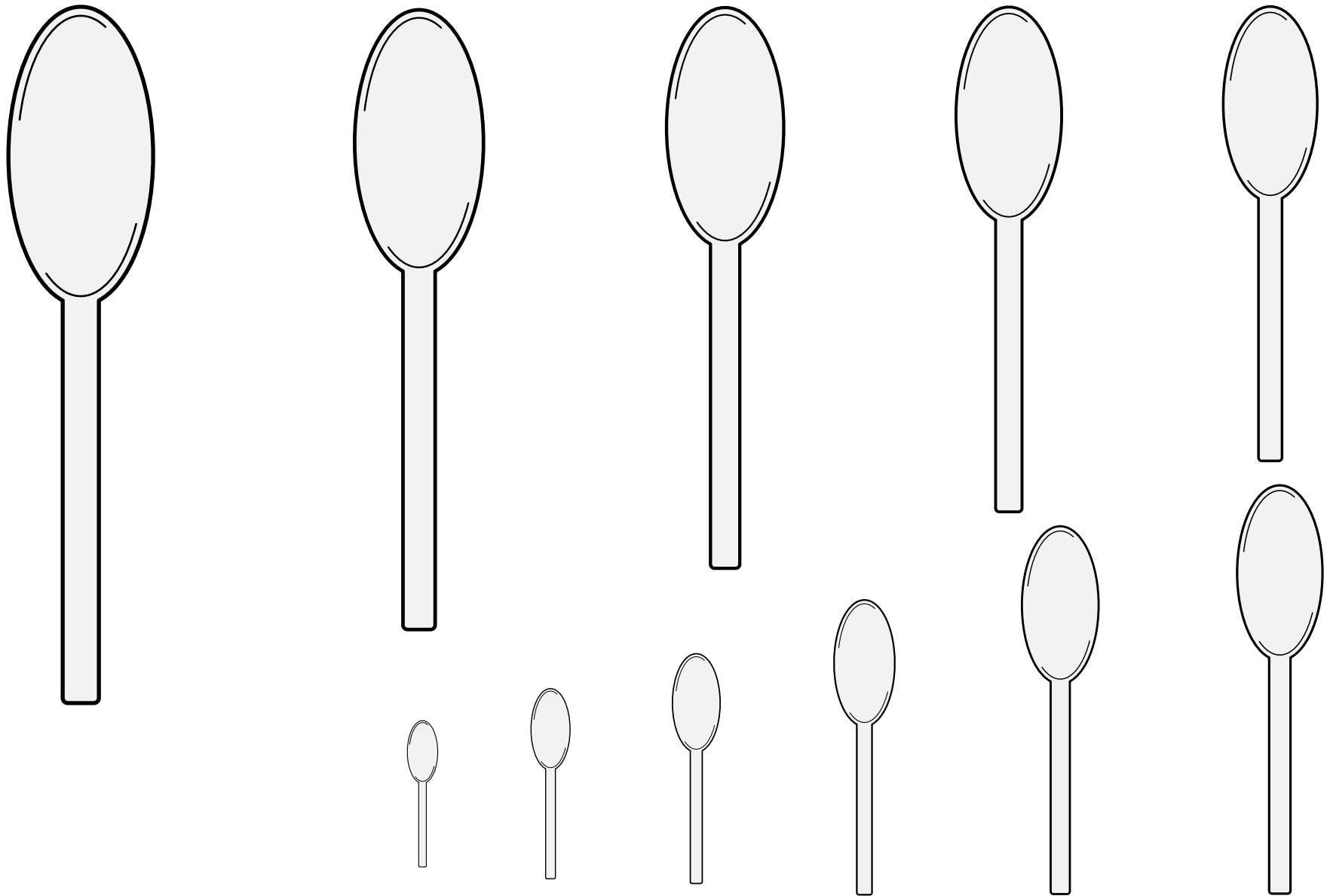

A utensil for eating or stirring food.

Default orientation: palewise, handle to base. No proper coloration.

Source: Wappenbuch der Arlberg-Bruderschaft.

Artist: Vigil Raber. (Page 82.)

Spoon (5) 14.156

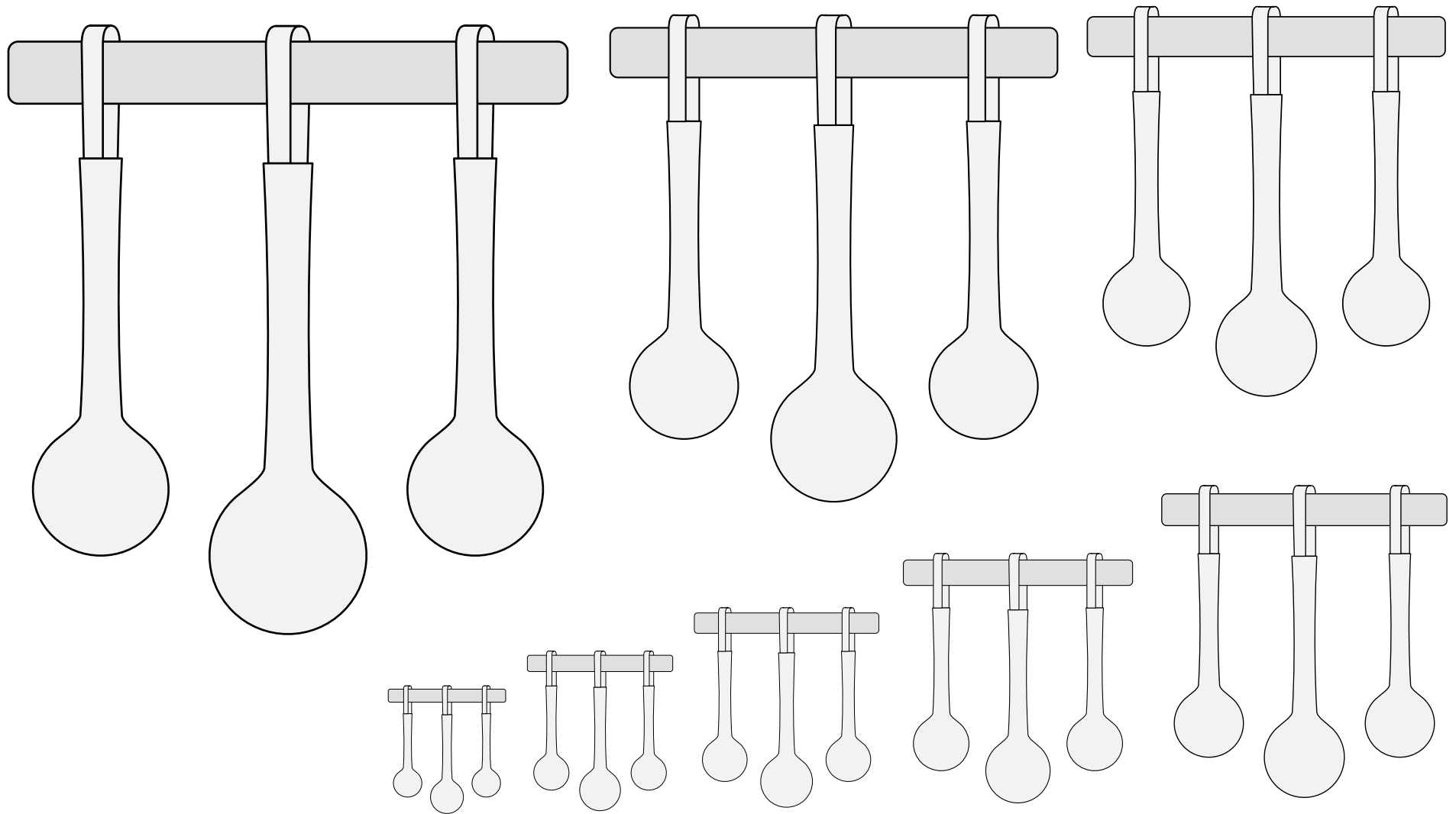

A utensil for eating or stirring food.

Default orientation: palewise, handle to base. No proper coloration.

Source: St. Gallen Armorial.

Artist unknown.

(Page 323, arms of von Hoffen.)

Spoons, Three, Hanging from a Rail 14.157

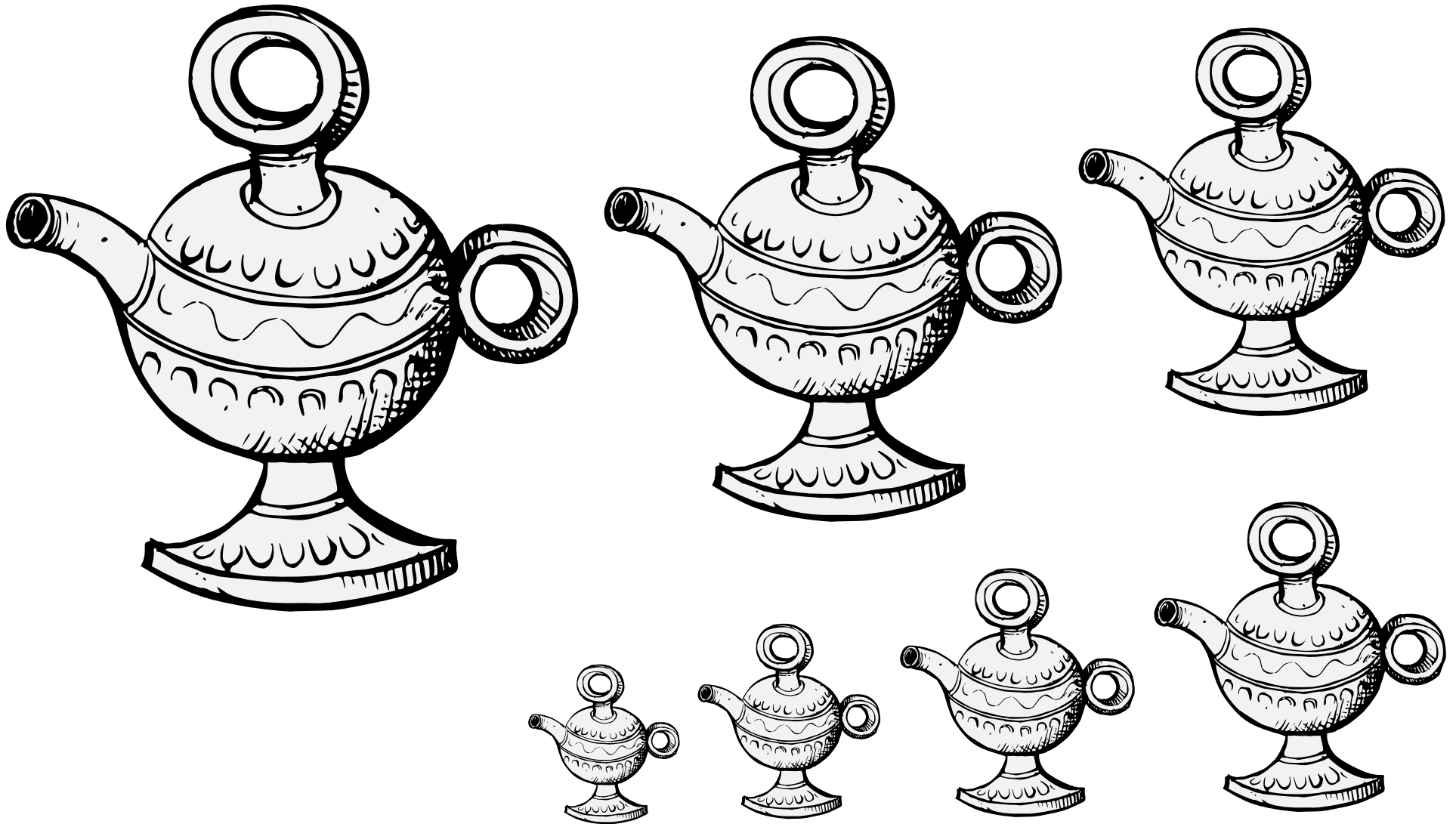

A container used to carry and pour water or other fluids.

Default orientation: palewise, spout to dexter. No proper coloration.

Source: Scheibler Armorial. Artist unknown.
(Arms of Schilling von Cannstatt, page 126.)

Spouted Pot (1) 14.158

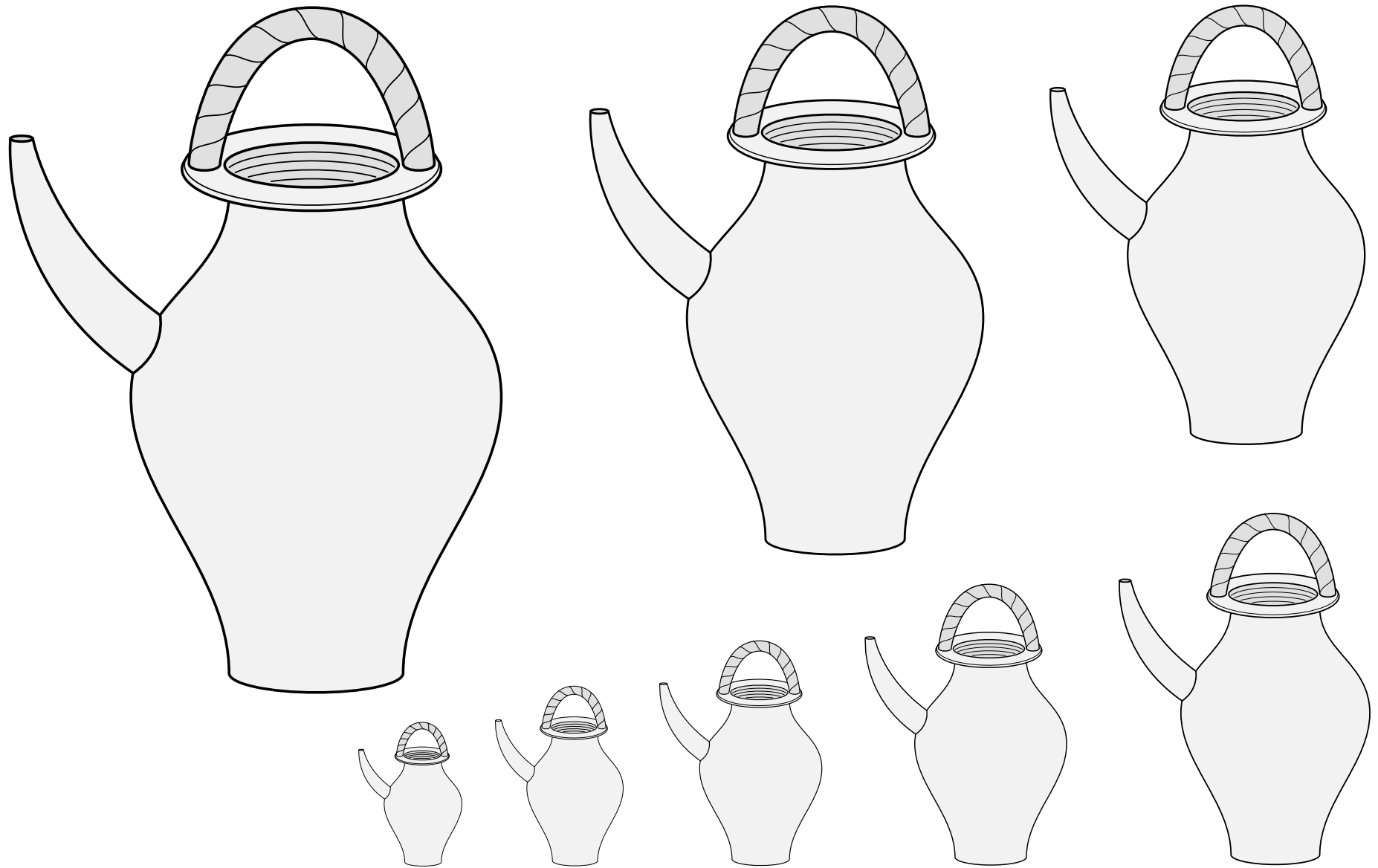

A container used to carry and pour water or other fluids.
Default orientation: palewise, spout to dexter. No proper coloration.
Source: Neustifter Wappenbuch. Artist: Vigil Raber.

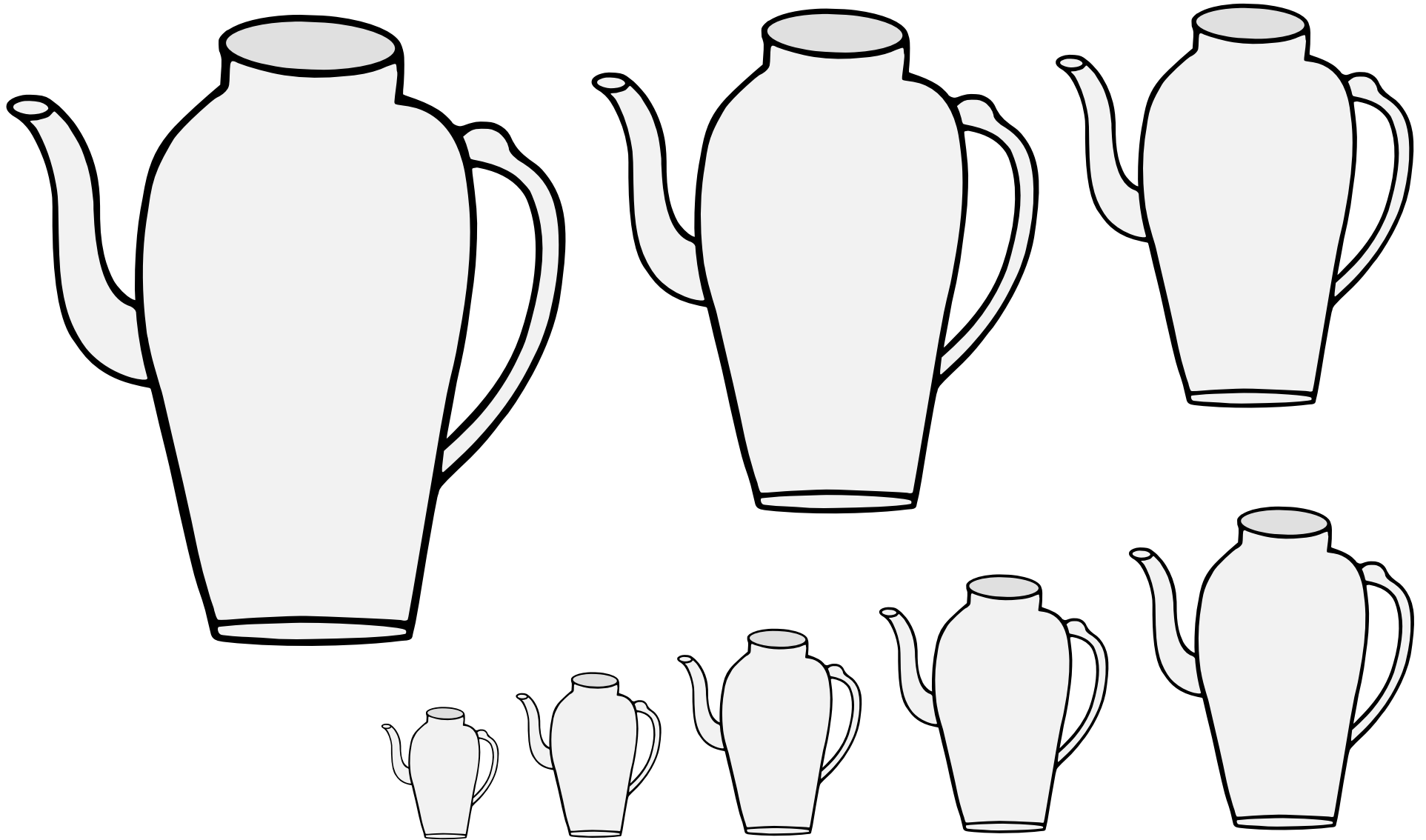

A container used to carry and pour water or other fluids.

Default orientation: palewise, spout to dexter. No proper coloration.

Source: Kenmon Shokamon. Artist unknown. (Page 35.)

Adapted by Jessimond of Emerickeskepe.

Spouted Pot (3) 14.160



A metal or wooden mug such as might be used to drink beer. May be drawn with a lid.

Default orientation: upright. No proper coloration.

Source: Pennsic Traceable Art. Artist unknown.

Tankard (1) 14.161



A metal or wooden mug such as might be used to drink beer. May be drawn with a lid.
Default orientation: upright. No proper coloration.
Source: Pennsic Traceable Art. Artist unknown.



A metal or wooden mug such as might be used to drink beer. May be drawn with a lid.

Default orientation: upright. No proper coloration.

Source: Pennsic Traceable Art. Artist unknown.

Tankard (3) 14.163

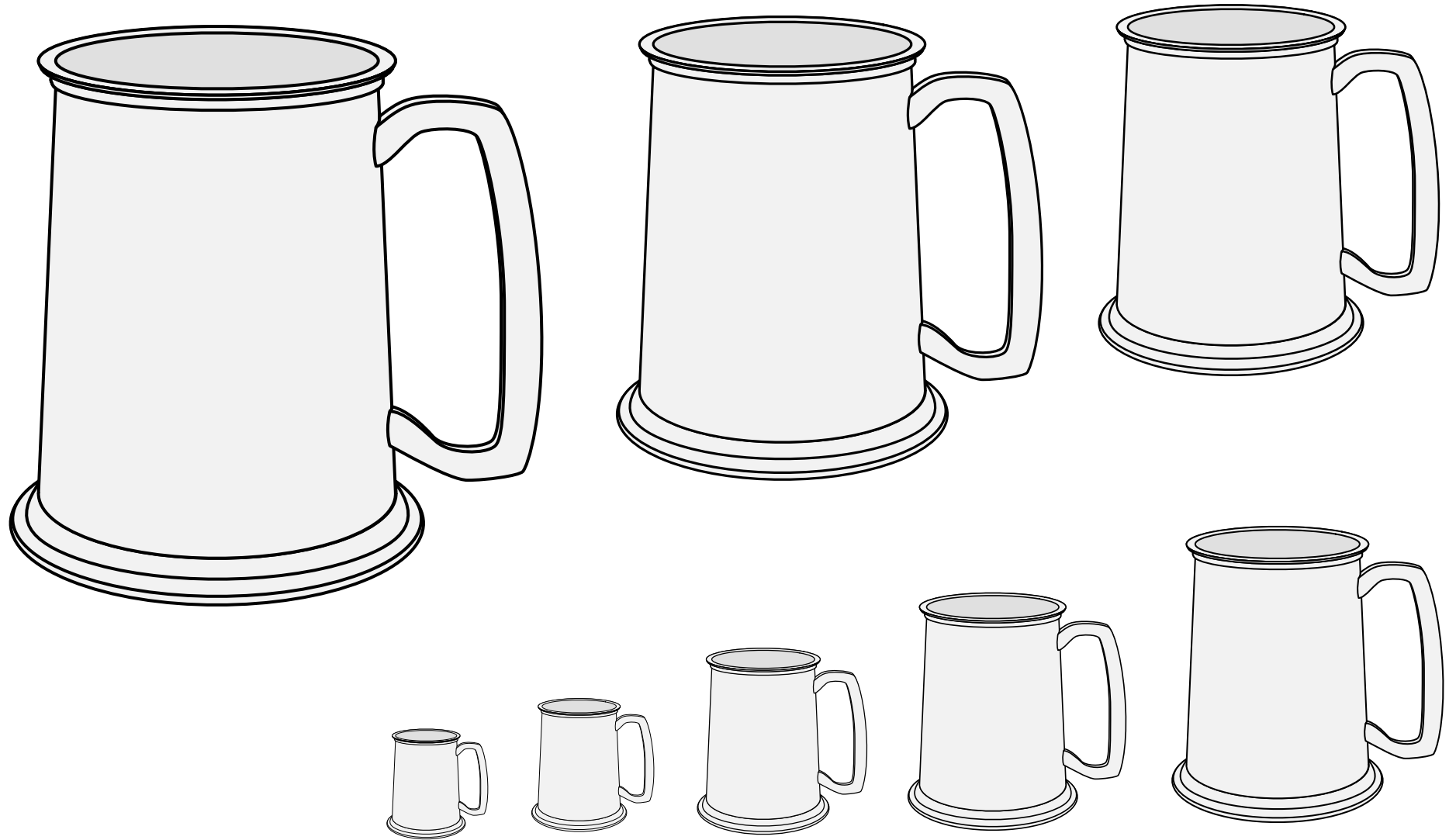

A metal or wooden mug such as might be used to drink beer. May be drawn with a lid.

Default orientation: upright. No proper coloration.

Artist: Mathghamhain Ua Ruadháin. Based on images of pewter tankards.

Tankard (4) 14.164



A metal or wooden mug such as might be used to drink beer. May be drawn with a lid.

Default orientation: upright. No proper coloration.

Artist: Jessimond of Emerickeskepe.

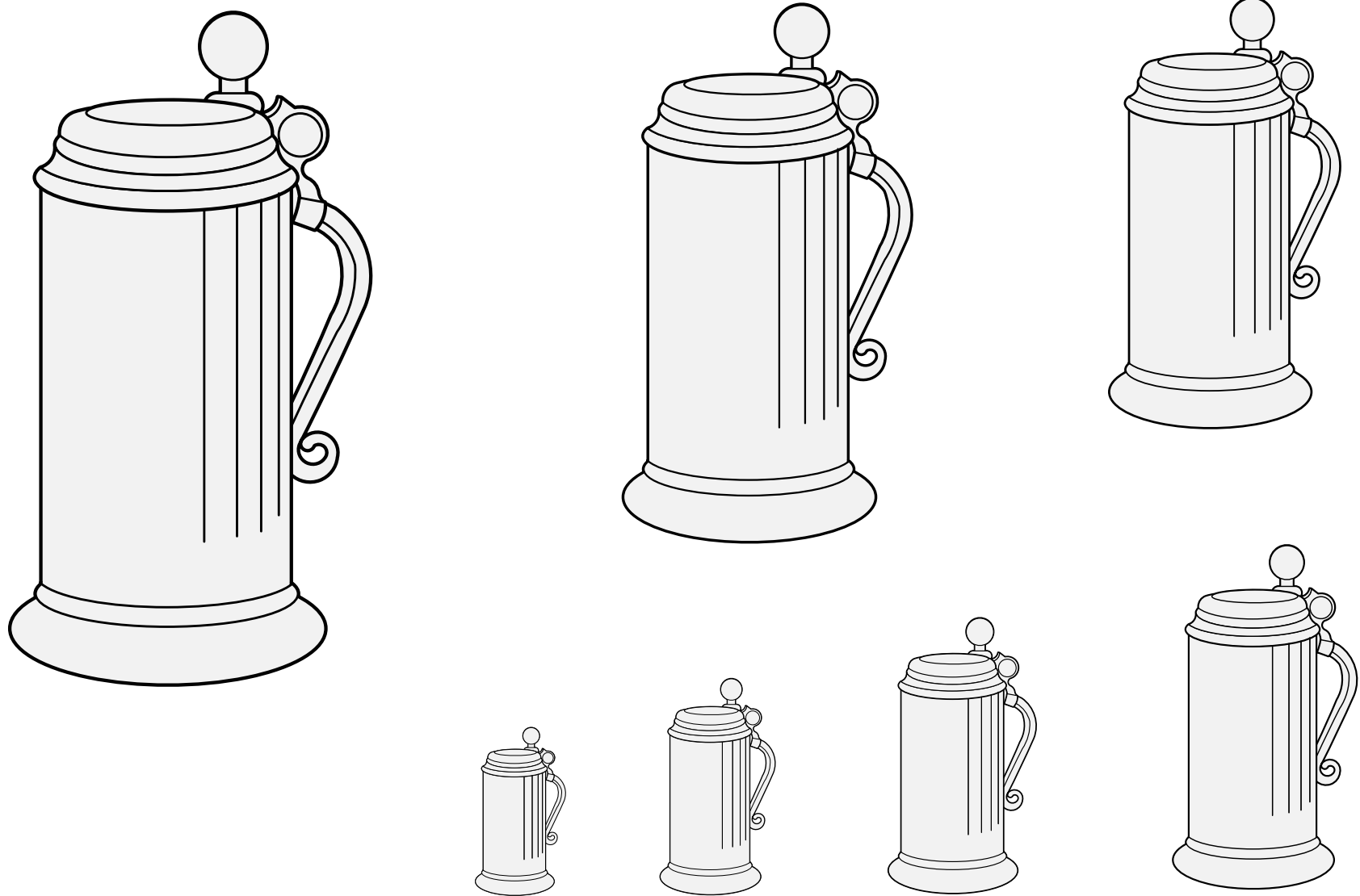

A metal or wooden mug such as might be used to drink beer. May be drawn with a lid.

Default orientation: upright. No proper coloration.

Source: Viking Answer Lady SVG Images For Heraldry.

Artist: Gunnvör silfrhárr.

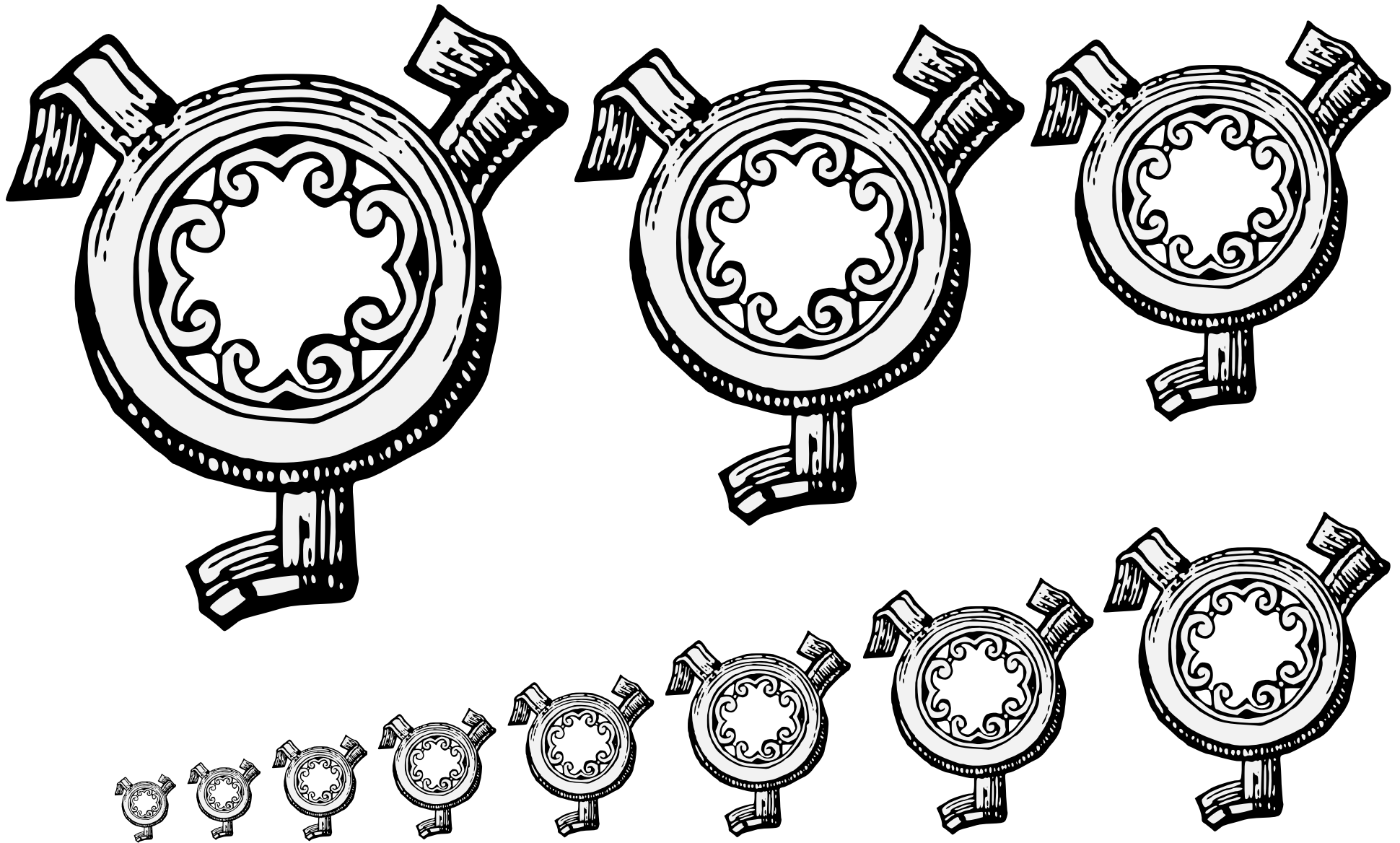

A small stand with three legs used to support a hot pot.

Default orientation: in annulo, all three legs visible. No proper coloration.

Source: Guillim's Display of Heraldry. Artist unknown.

Trivet (1) 14.167

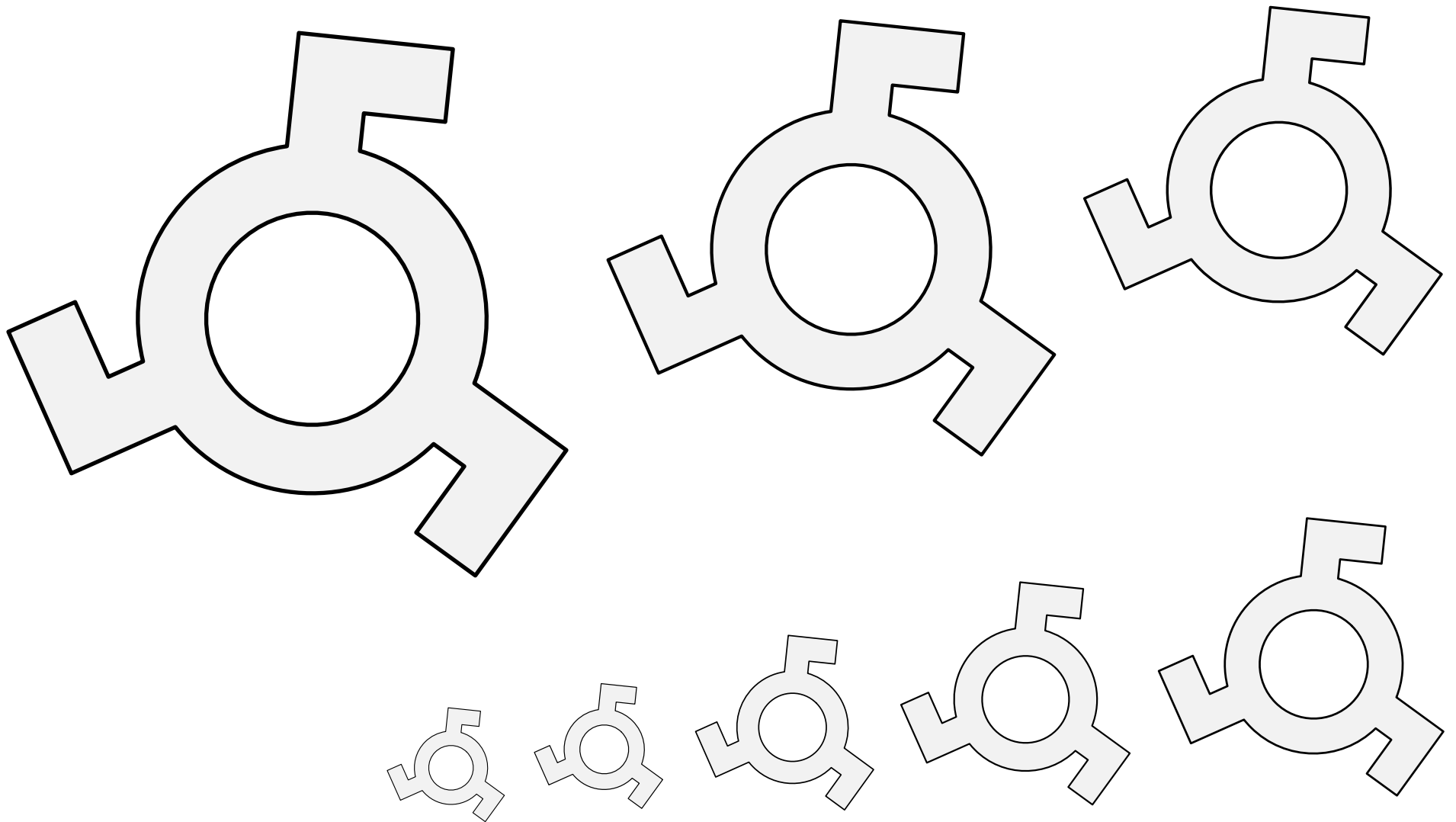

A small stand with three legs used to support a hot pot.

Default orientation: in annulo, all three legs visible. No proper coloration.

Source: Insignia Anglica. Artist unknown. (From folio 37.)

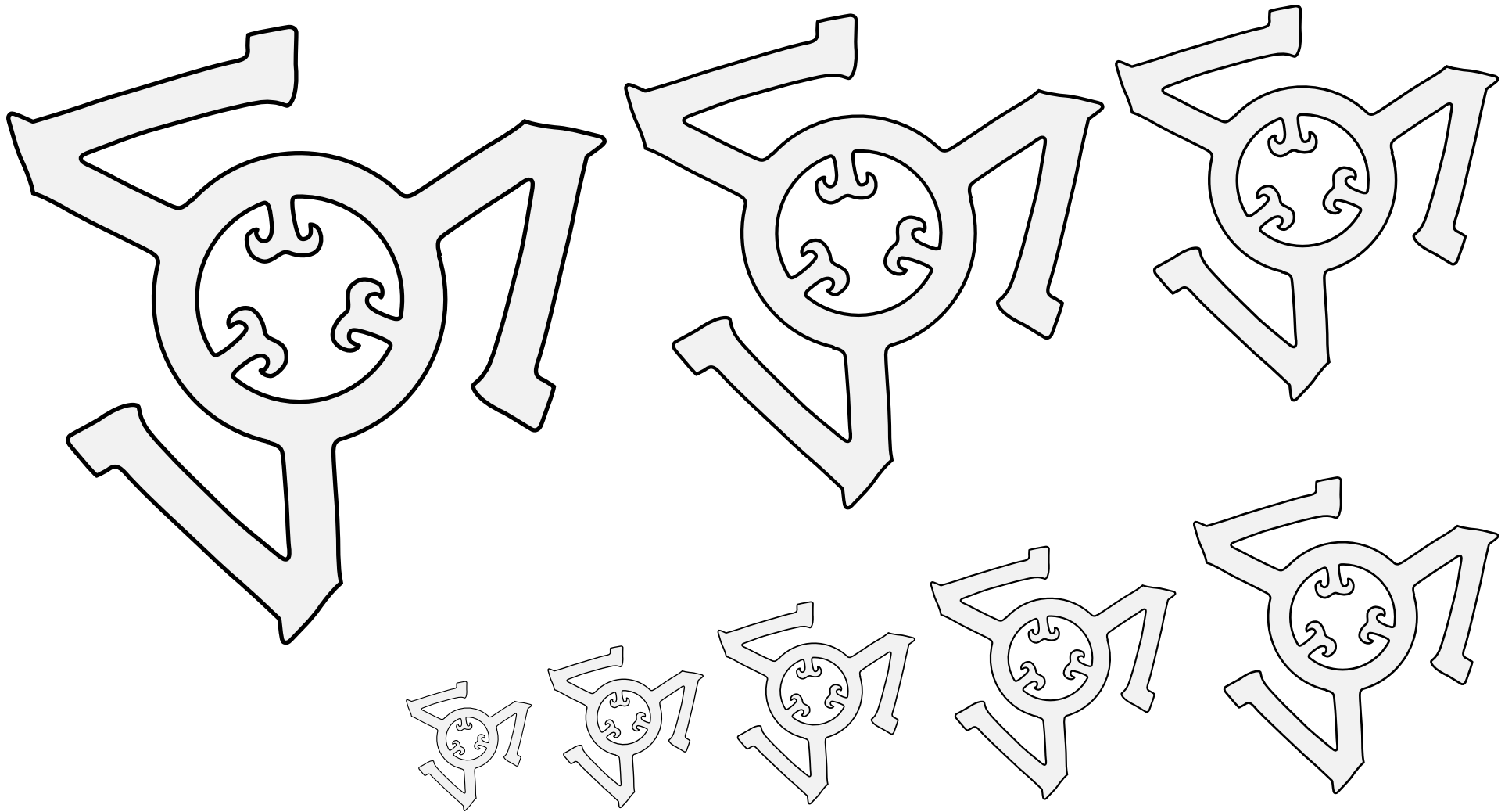

A small stand with three legs used to support a hot pot.

Default orientation: in annulo, all three legs visible. No proper coloration.

As of the April 2023 LoAR, this design was ruled unregistrable due to its resemblance to the *triskelion gammadion* used as the insignia of some neo-Nazi movements including the Afrikaner Weerstandsbeweging.

Source: Bellenville Armorial. Artist unknown. (Folio 6v.)

Trivet (3) 14.169

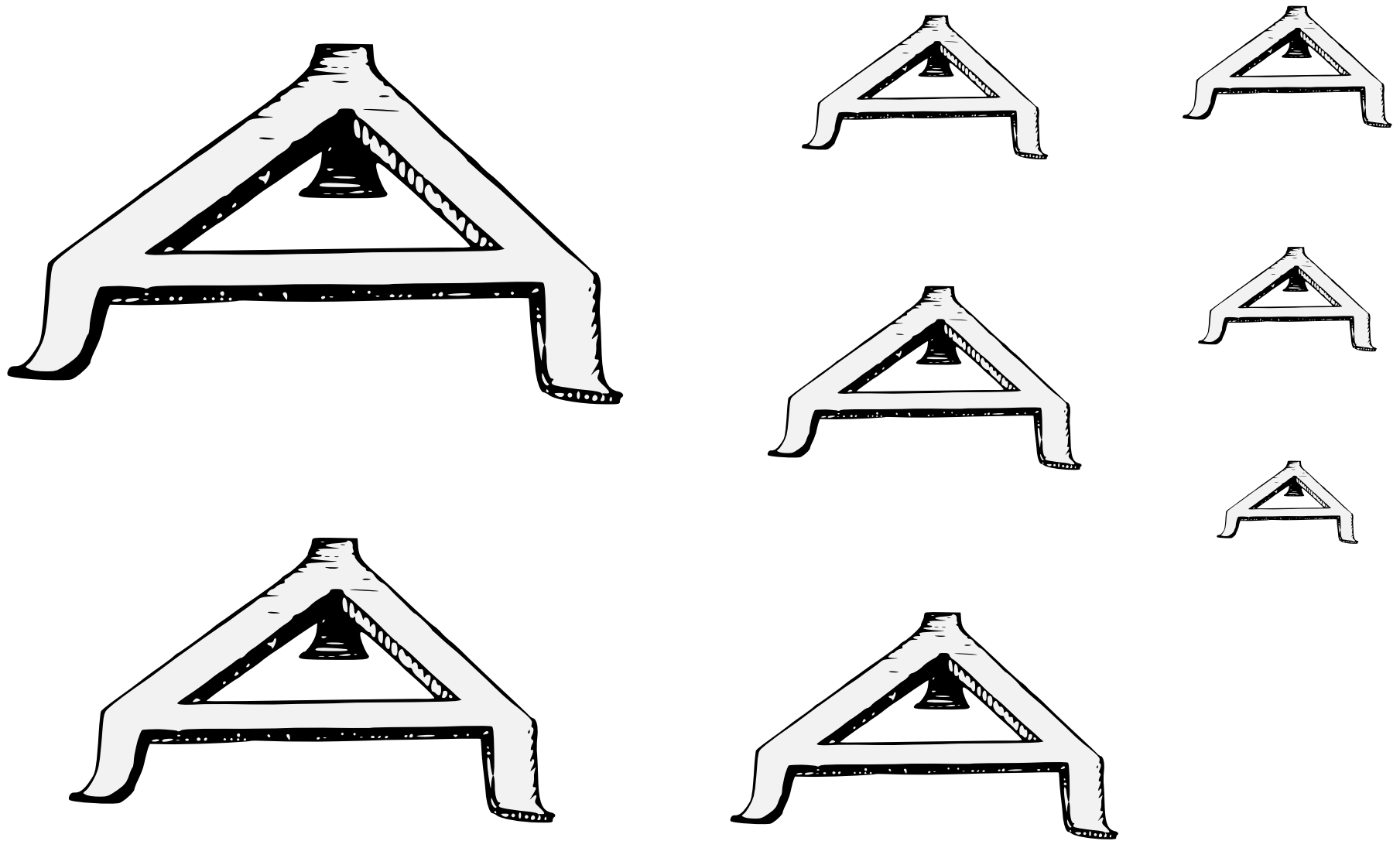

A small stand with three legs used to support a hot pot.
Default orientation: in annulo, all three legs visible. No proper coloration.
Source: Opera Dell'arte Del Cucinare. Artist unknown. (Page 951.)

Trivet, Triangular 14.170

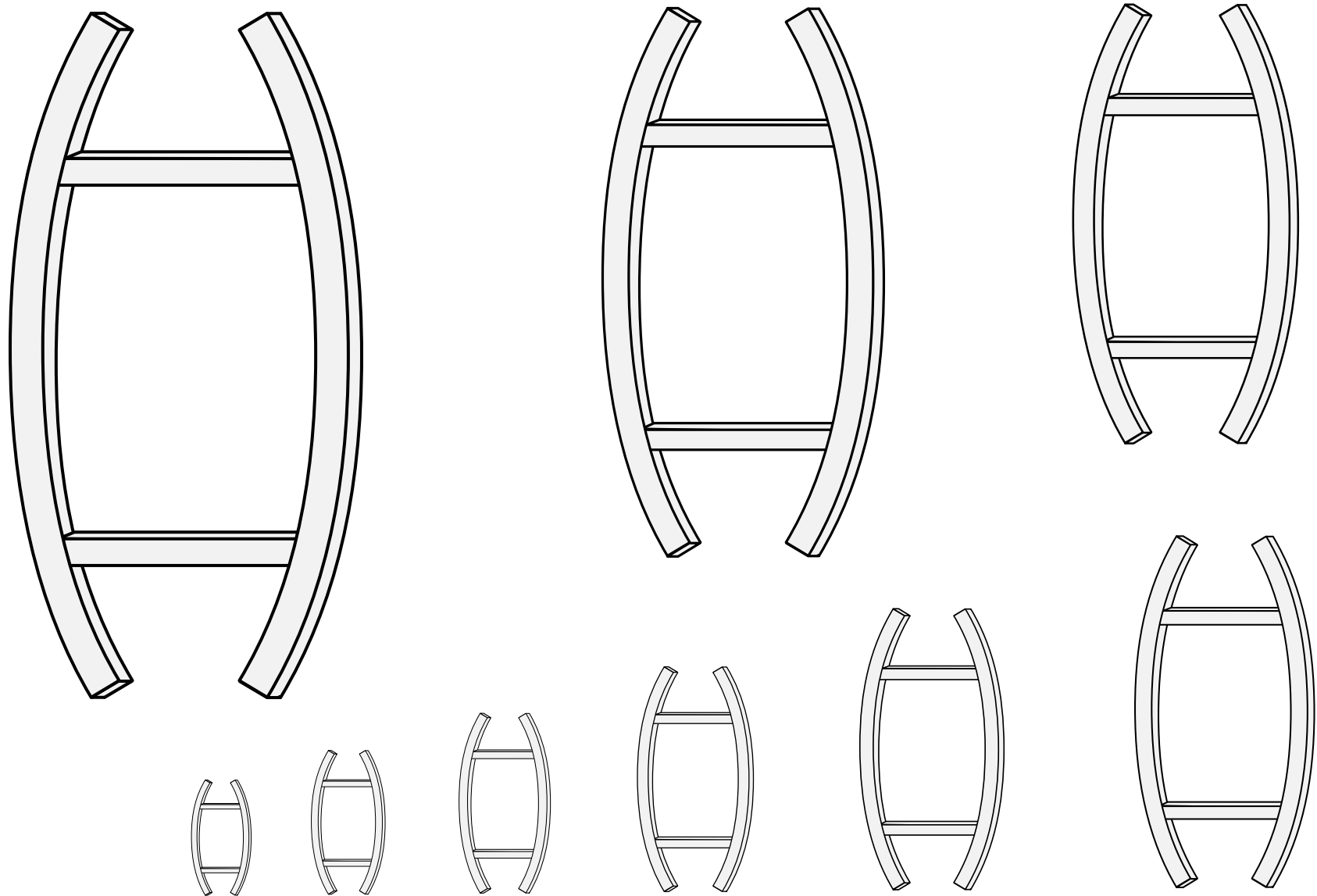

A framework used to carry wine barrels.

No default orientation. No proper coloration.

Source: BnF MS Allemand 304. Artist unknown. (Page 611.)

Weinleiter (1) 14.171

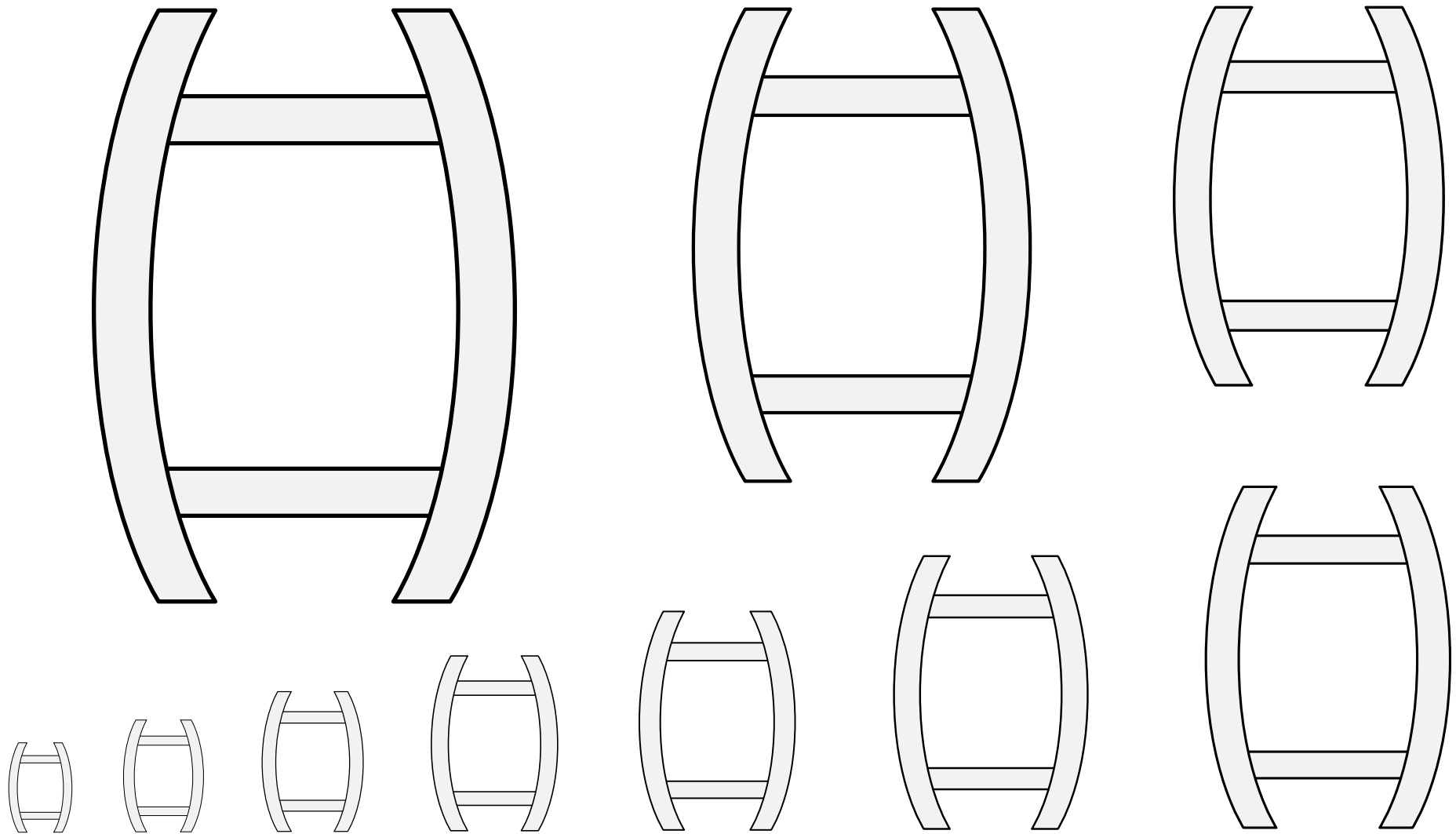

A framework used to carry wine barrels.

No default orientation. No proper coloration.

Source: BnF MS Allemand 304. Artist unknown. (Page 474.)

Weinleiter (2) 14.172