

❖ Book of Traceable Heraldic Art ❖

Volume 16:

Tools

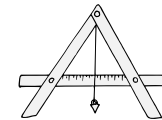
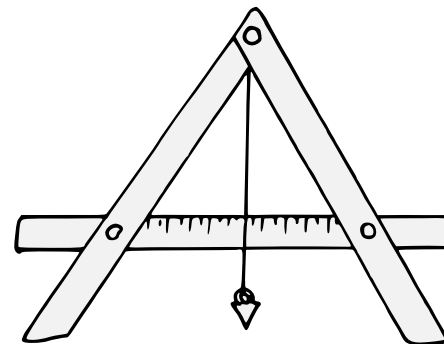
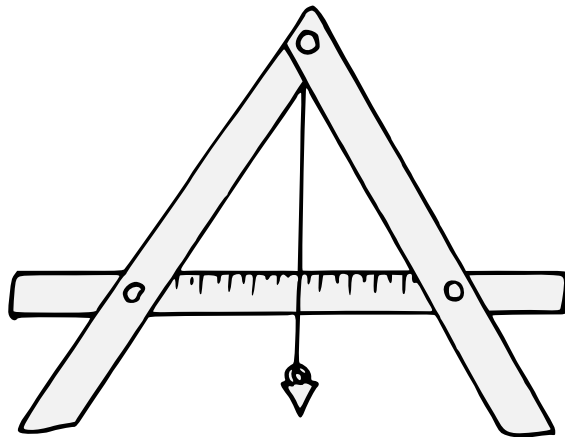
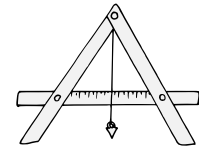
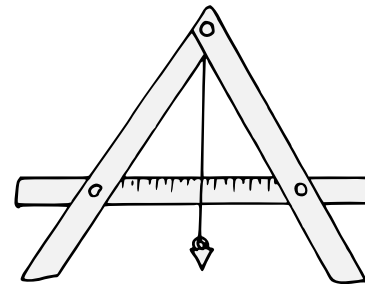
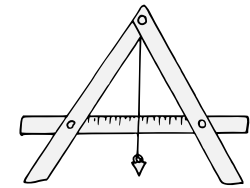
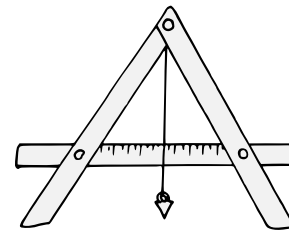
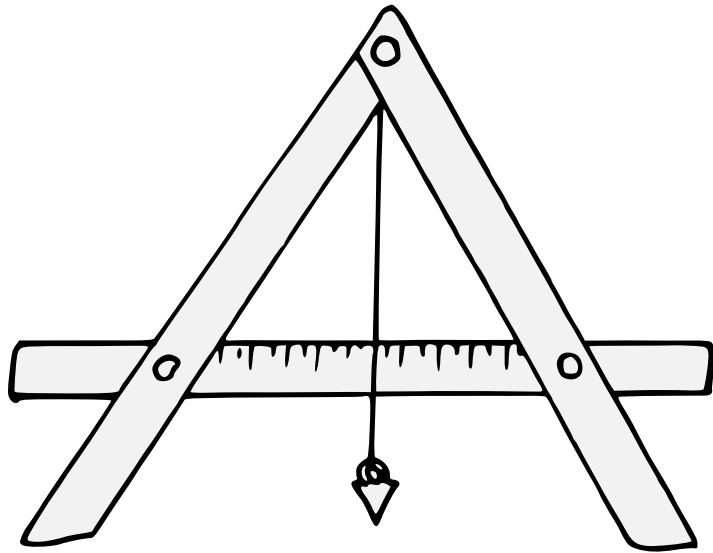

A builder's tool for ensuring surfaces are horizontal or vertical.
Default orientation: weight to base. Proper coloration: brown wood.
Source: Heraldic Templates. Artist: Torric inn Björn.

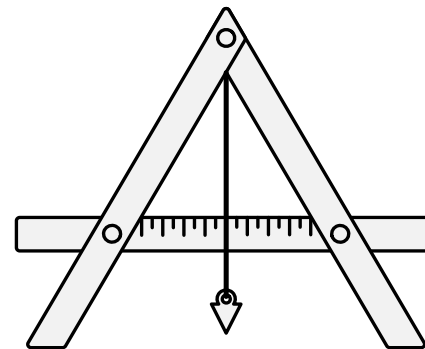
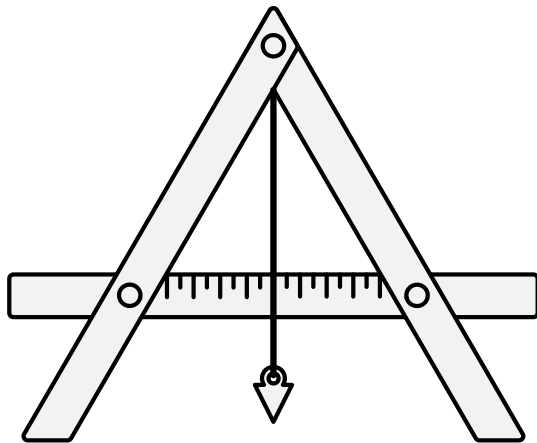
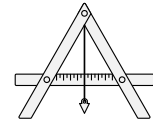
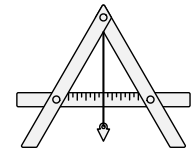
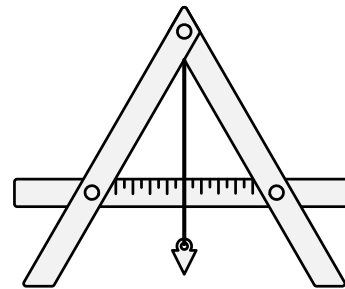
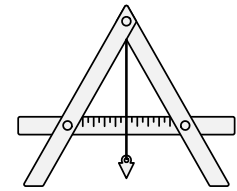
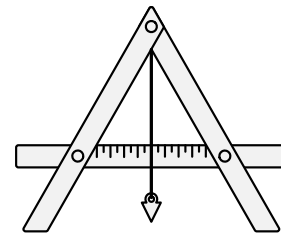
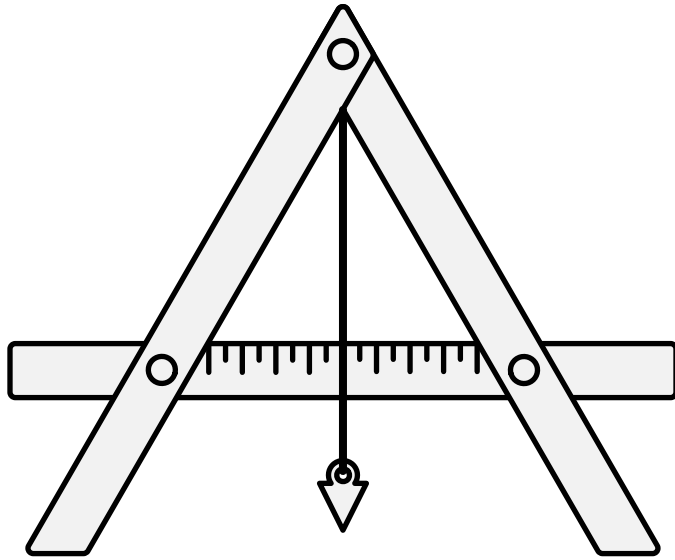

A builder's tool for ensuring surfaces are horizontal or vertical.
Default orientaiton: weight to base. Proper coloration: brown wood.
Source: Heraldic Templates. Artist: Torric inn Björn.
Adapted by Mathghamhain Ua Ruadháin.

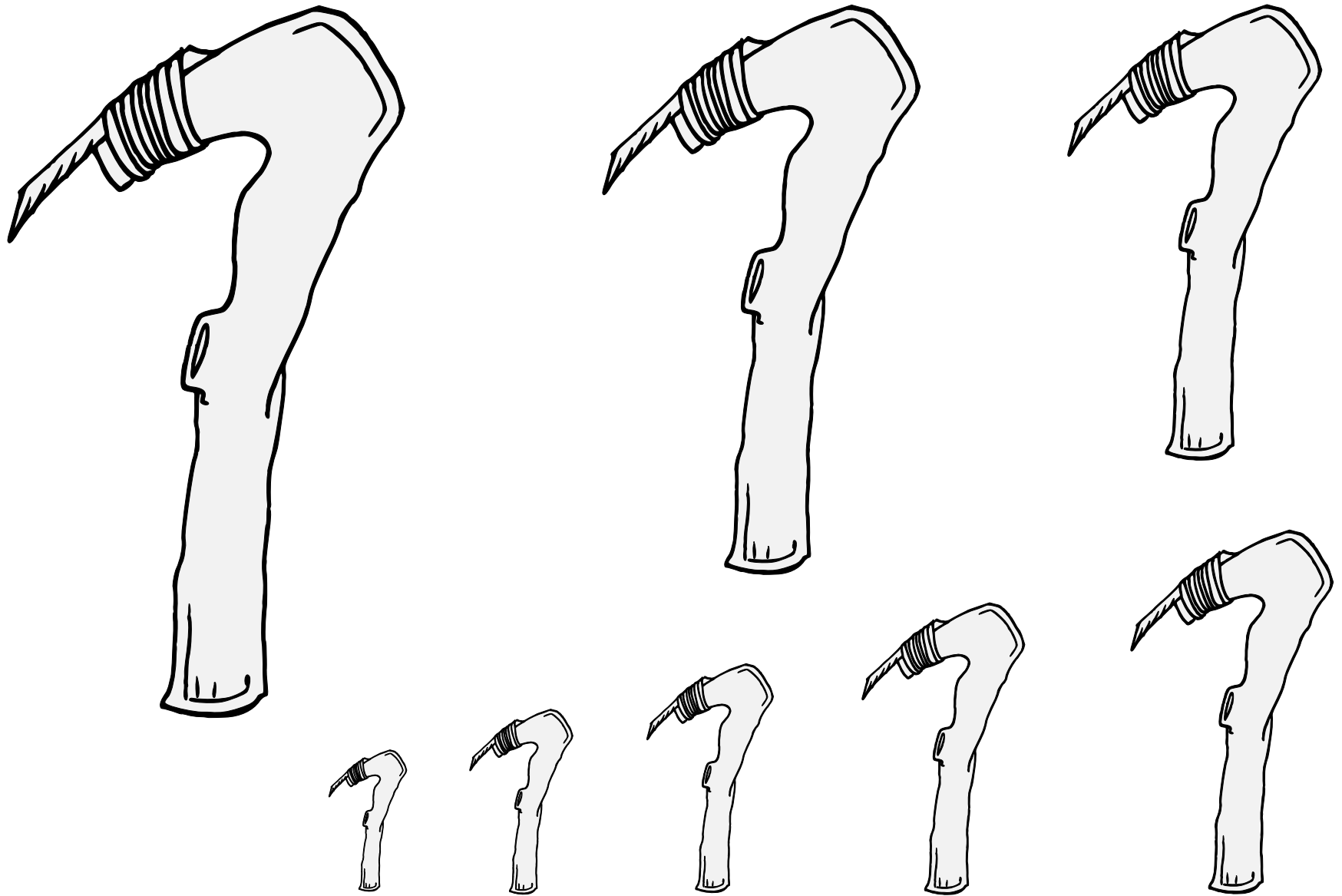

A tool for shaping pieces of wood.

Default orientation: handle to base, cutting to dexter. No proper coloration.

Source: Pennsic Bored-Artist Collection. Artist: `Aziza al-Shiraziyya.

Adze (1) 16.4

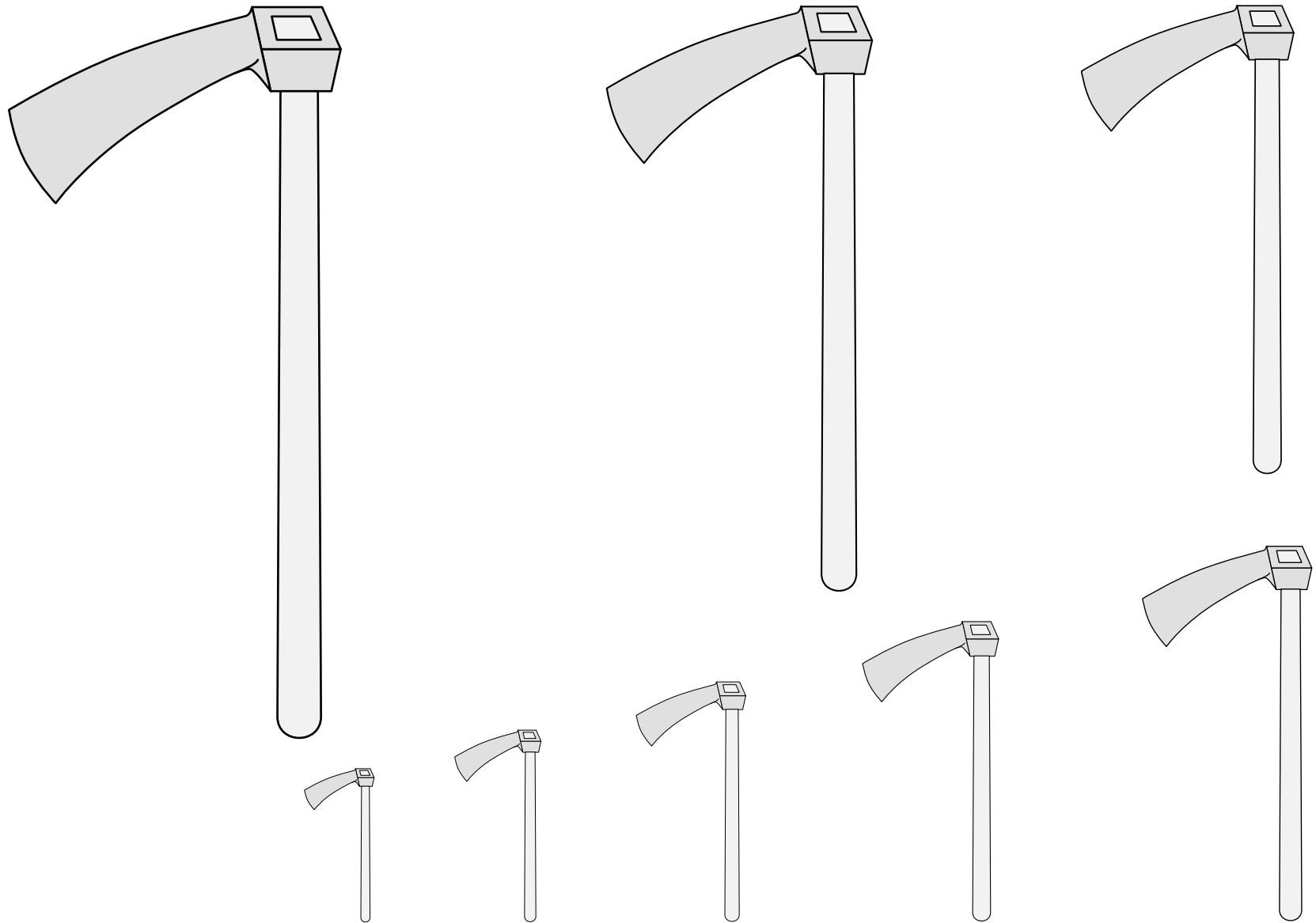

A tool for shaping pieces of wood.

Default orientation: handle to base, cutting to dexter. No proper coloration.

Source: Wappenbuch der Bruderschaft des heiligen Christophorus am Arlberg.
Artist unknown. (Folio 51v.)

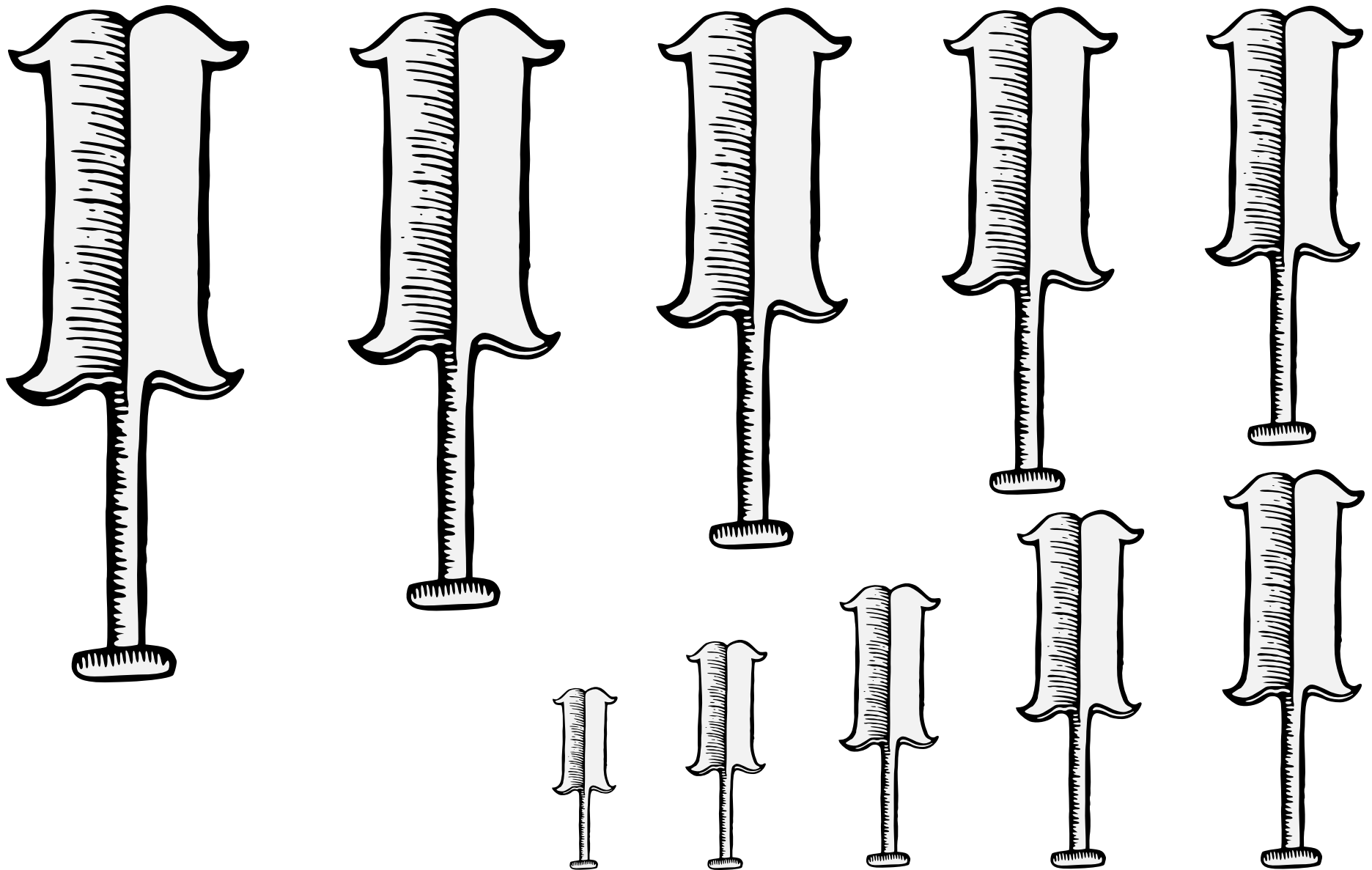

A tool for shaping pieces of wood.

Default orientation: handle to base, cutting to dexter. No proper coloration.

Source: Le Blason Des Armoiries. Artist: Jérôme de Bara.
(Page 129, blazoned a "timon antique," or old-style adze.)

Adze, Double-Bladed 16.6

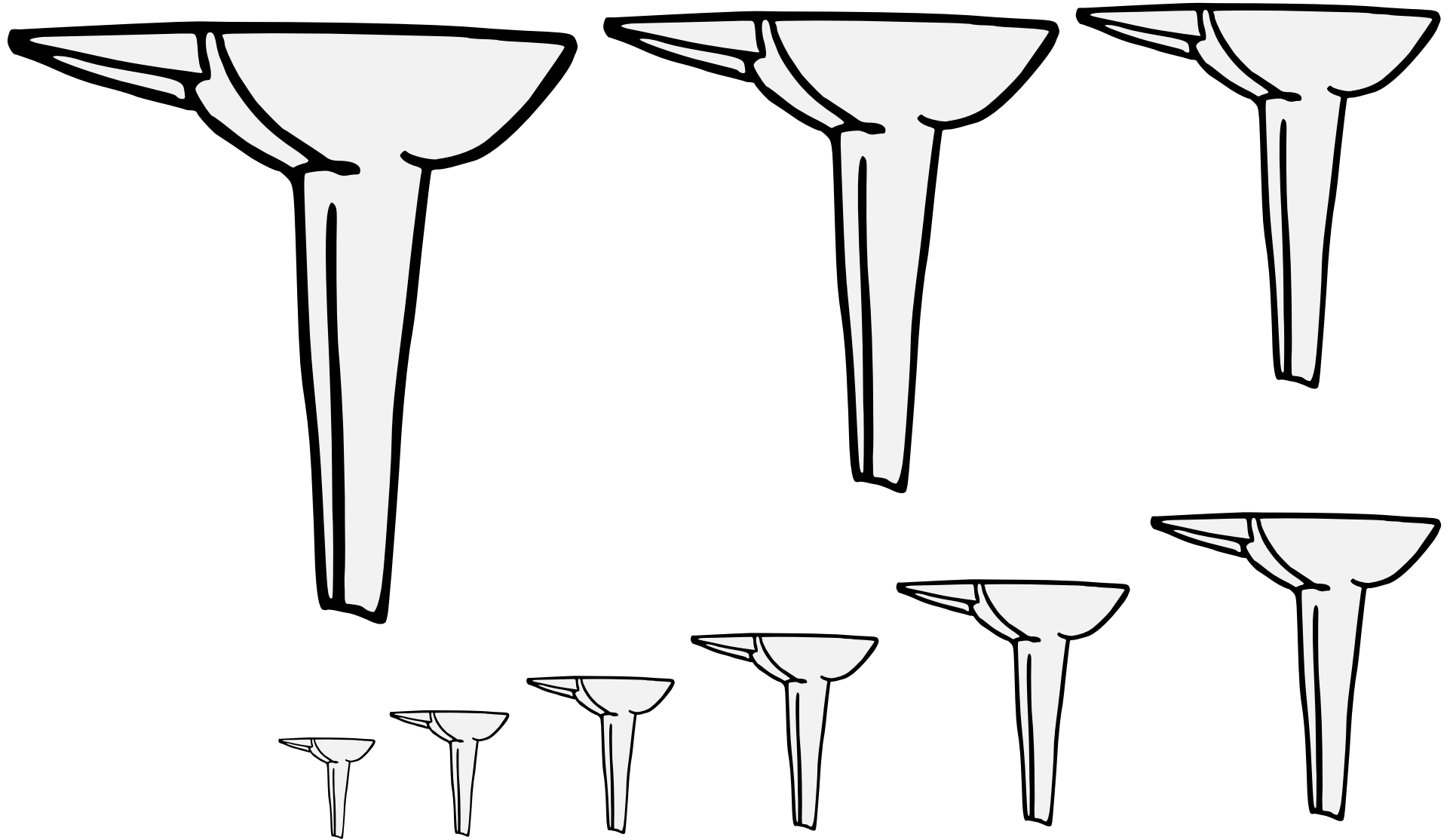

A solid base used for shaping metal.

Default orientation: flat surface to chief. No proper coloration.

Artist: Vémundr Syvursson.

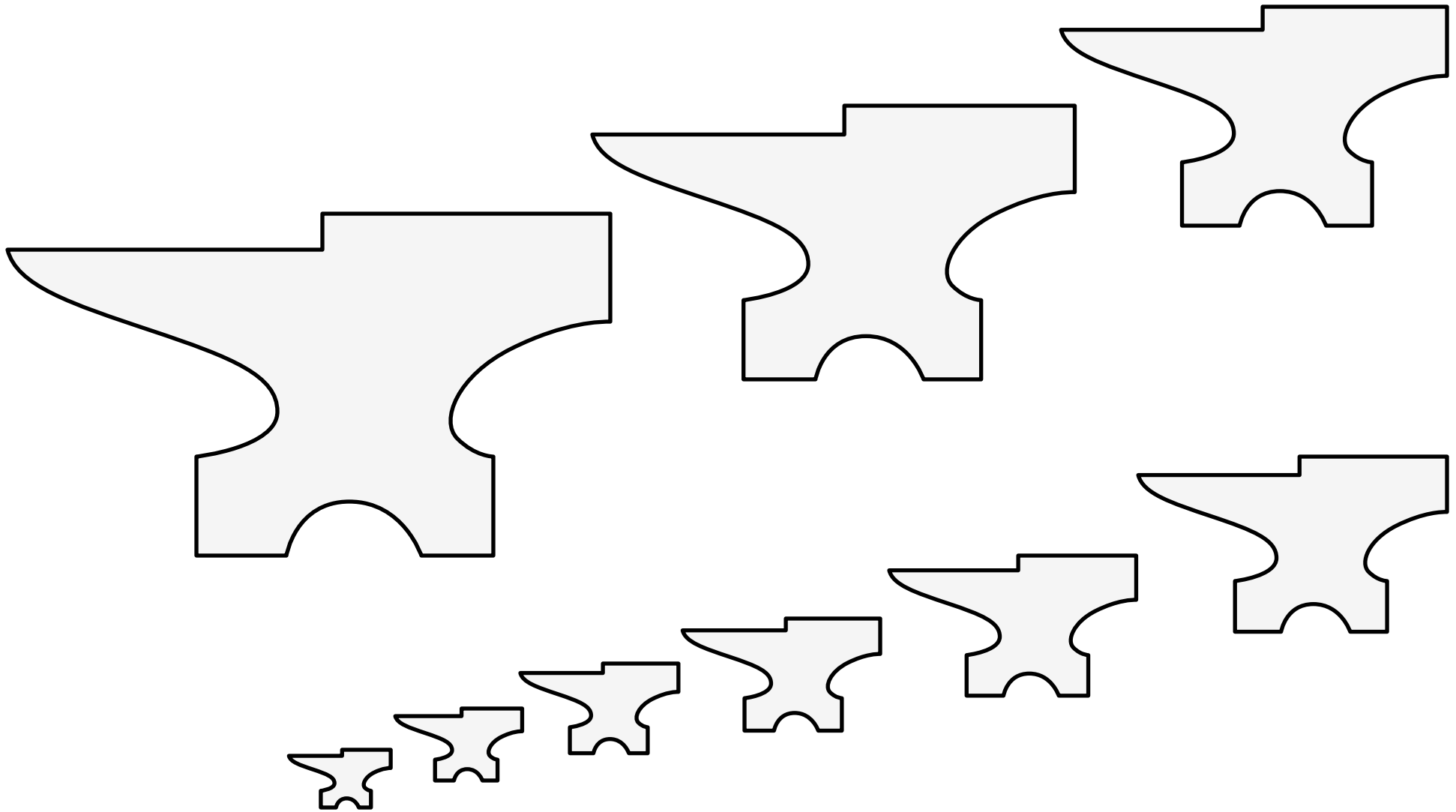

A solid base used for shaping metal.

Default orientation: flat surface to chief. No proper coloration.

Source: Pennsic Traceable Art. Artist: Roana d'Evreux.

Adapted by Mathghamhain Ua Ruadháin.

Anvil, One-horned (1) 16.8

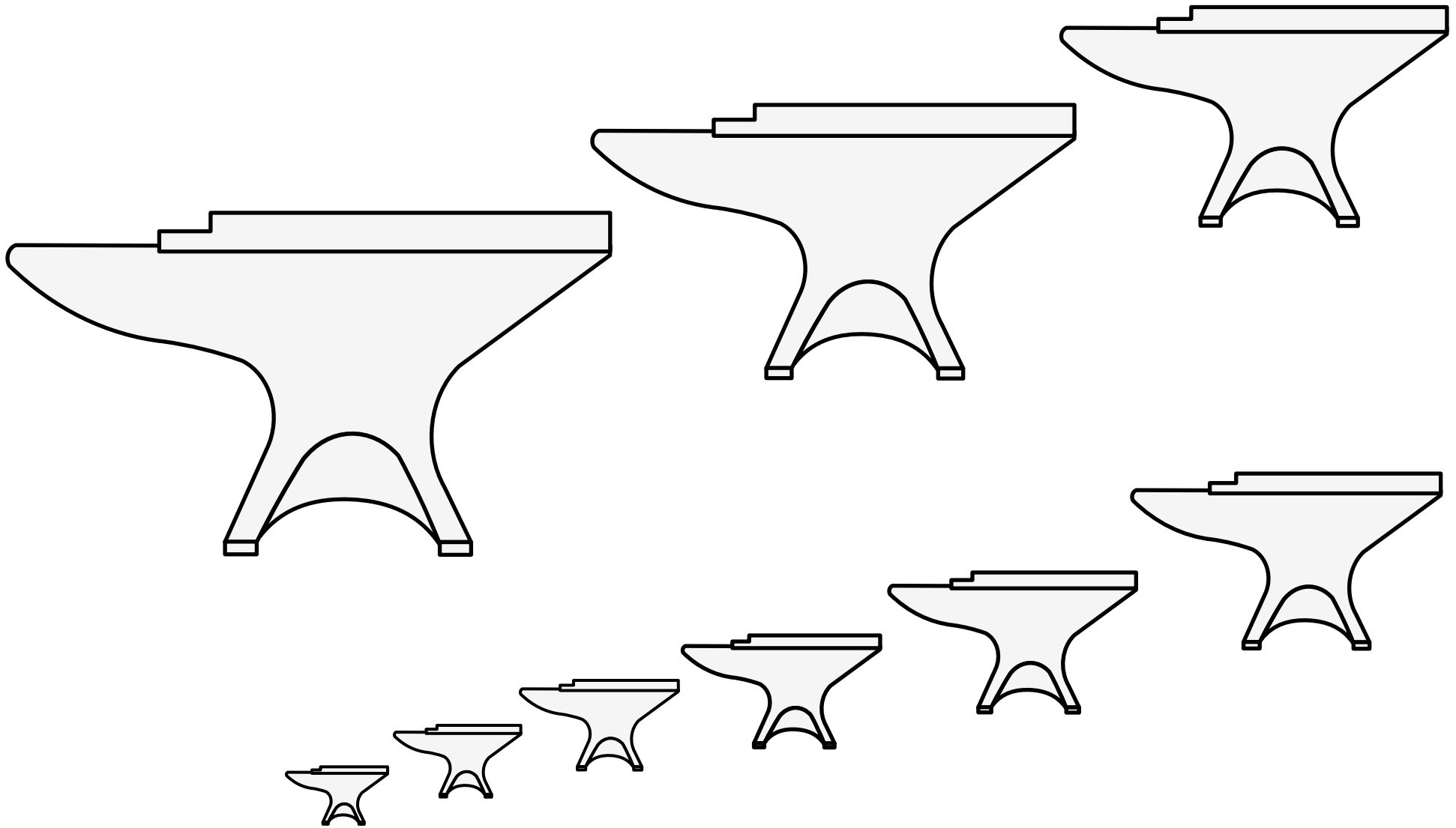

A solid base used for shaping metal.

Default orientation: flat surface to chief. No proper coloration.

Source: Viking Answer Lady SVG Images For Heralds.

Artist: Gunnvôr silfrahárr.

Anvil, One-horned (2) 16.9

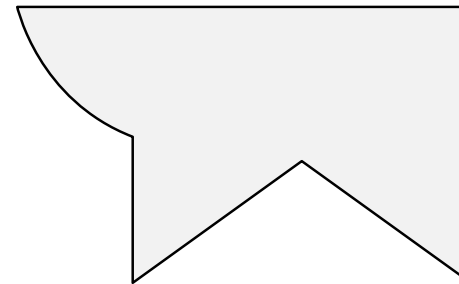
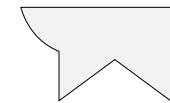
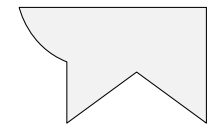
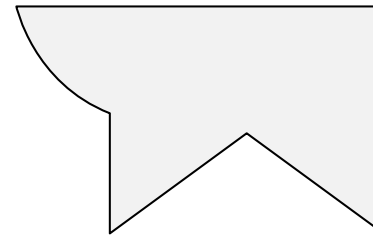
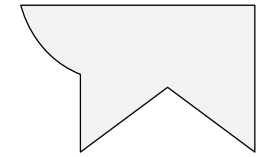
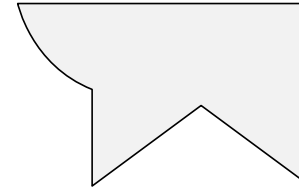
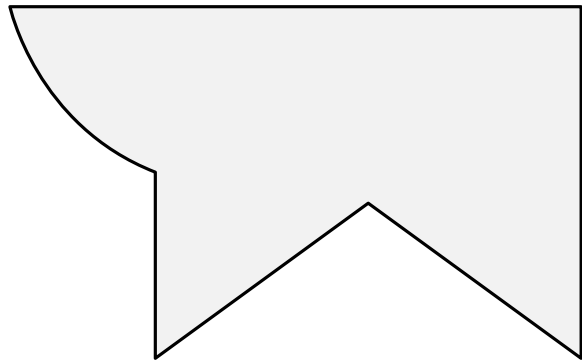
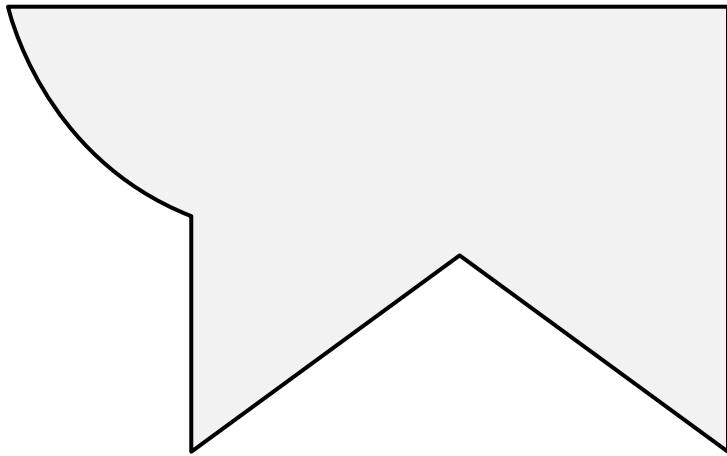

A solid base used for shaping metal.

Default orientation: flat surface to chief. No proper coloration.

Source: Stemmario Trivulziano.

Artist: Gian Antonio da Tradate. (Page 141.)

Anvil, One-horned (3) 16.10

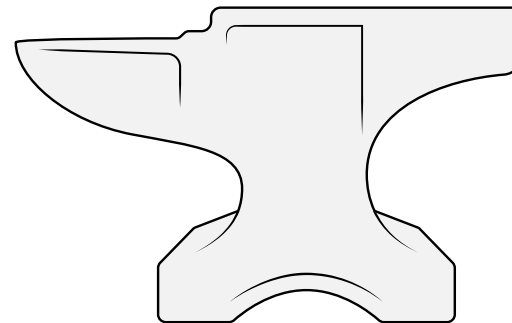
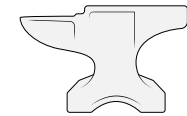
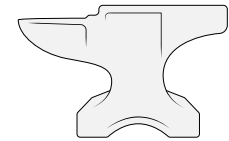
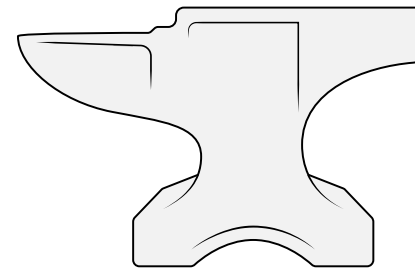
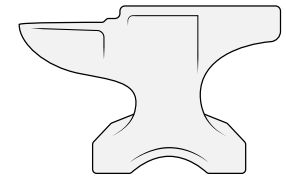
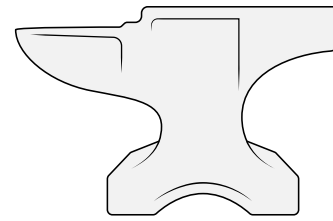
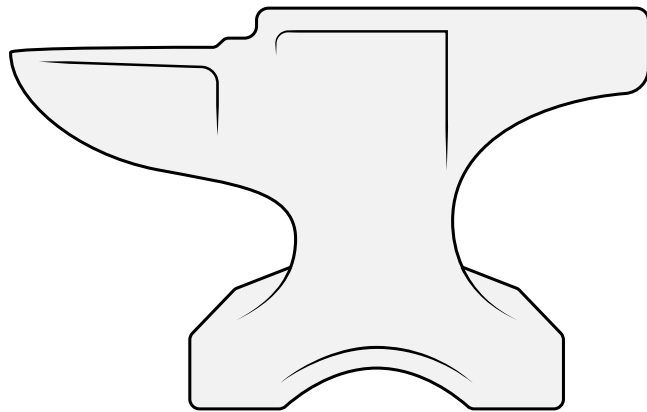
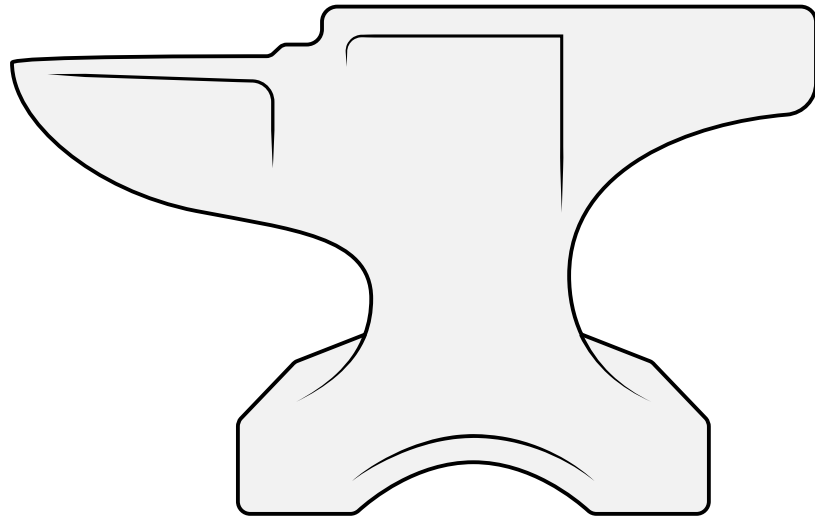

A solid base used for shaping metal.

Default orientation: flat surface to chief. No proper coloration.

Source: WappenWiki. Artist: Joakim Spuller.

Anvil, One-horned (4) 16.11

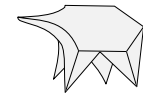
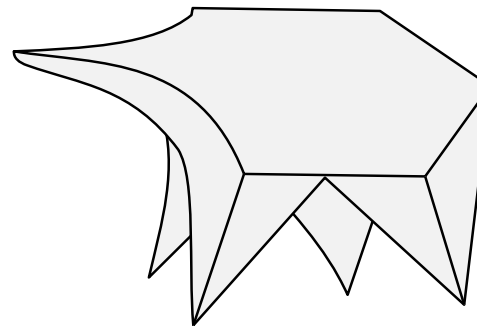
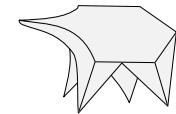
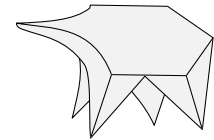
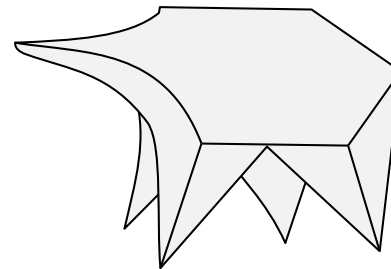
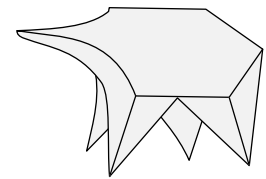
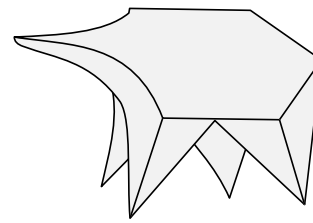
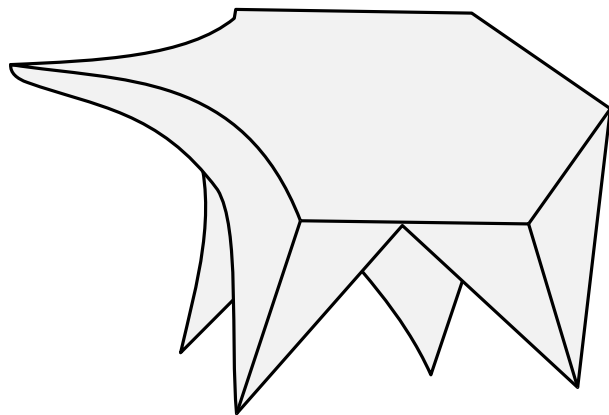
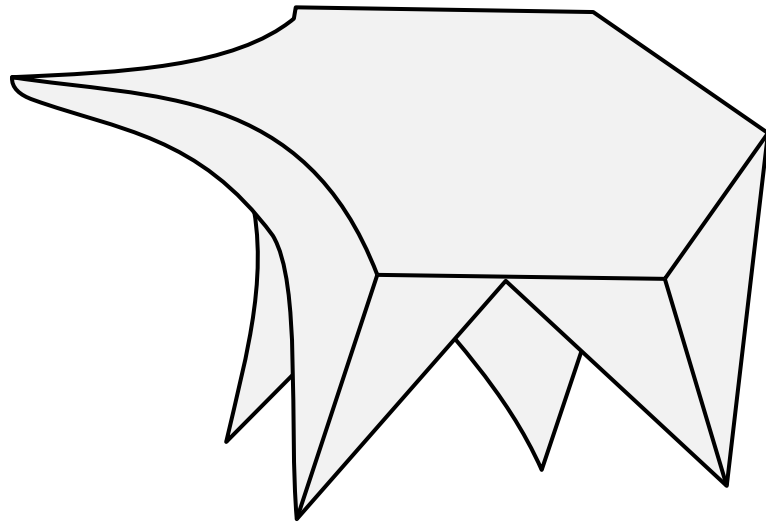

A solid base used for shaping metal.

Default orientation: flat surface to chief. No proper coloration.

Source: Insignia Urbium Italiae Septentrionalis. Artist: Unknown.
Adapted by Iago ab Adam.

Anvil, One-horned (5) 16.12

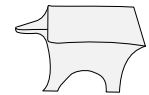
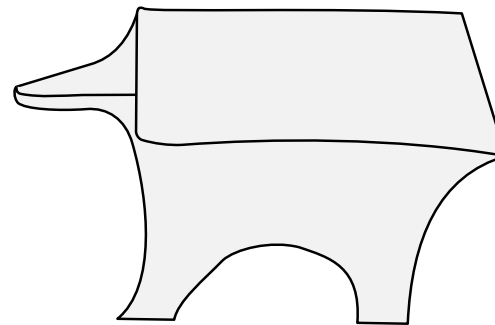
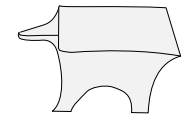
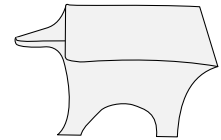
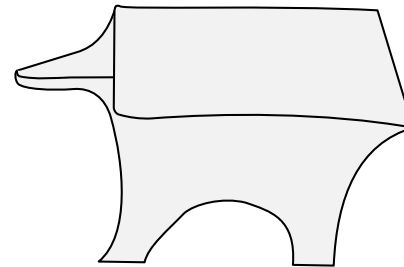
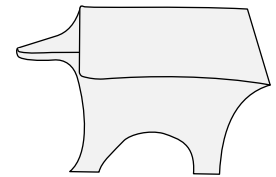
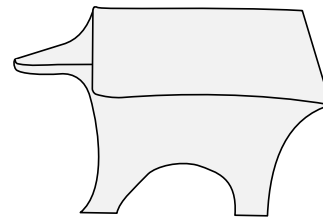
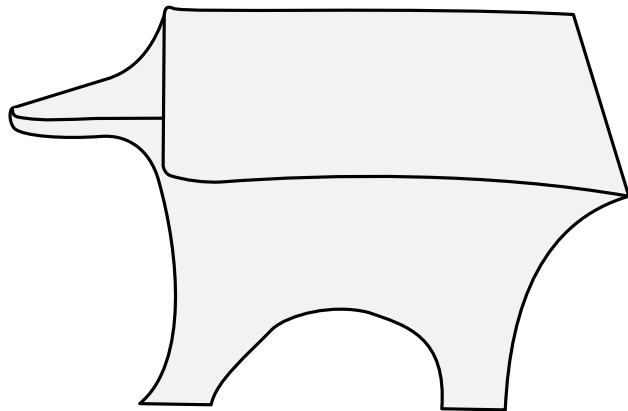
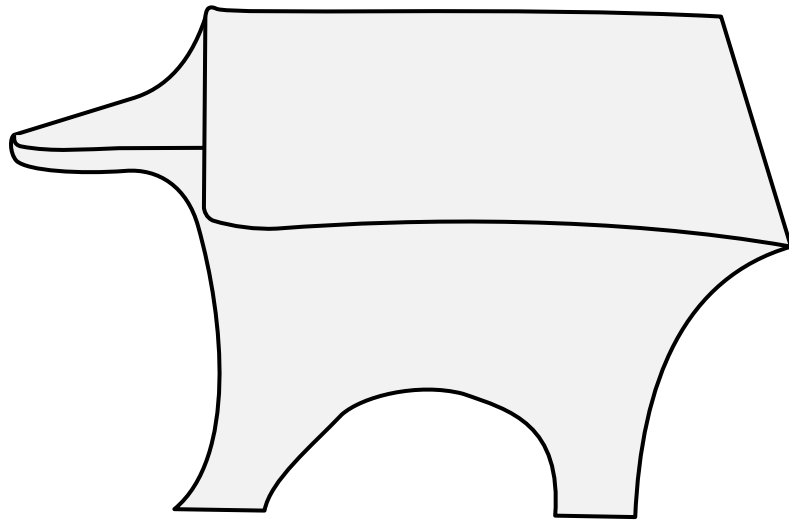

A solid base used for shaping metal.

Default orientation: flat surface to chief. No proper coloration.

Source: Insignia Urbium Italiae Septentrionalis. Artist: Unknown.
Adapted by Iago ab Adam.

Anvil, One-horned (6) 16.13

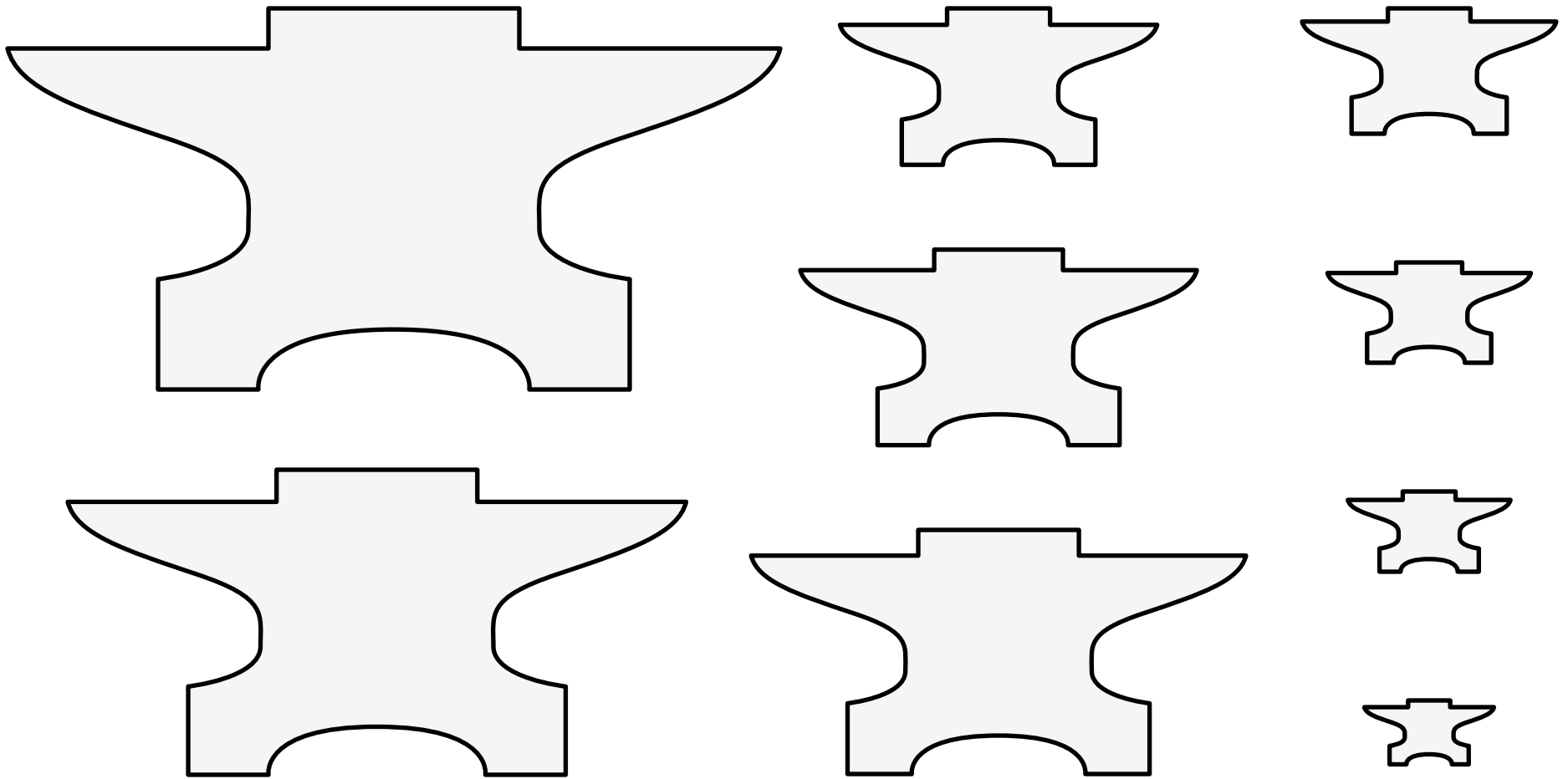

A solid base used for shaping metal.

Default orientation: flat surface to chief. No proper coloration.

Source: Pennsic Traceable Art. Artist: Myfanwy ferch Rhiannon.
Adapted by Mathghamhain Ua Ruadháin.

Anvil, Two-horned (1) 16.14

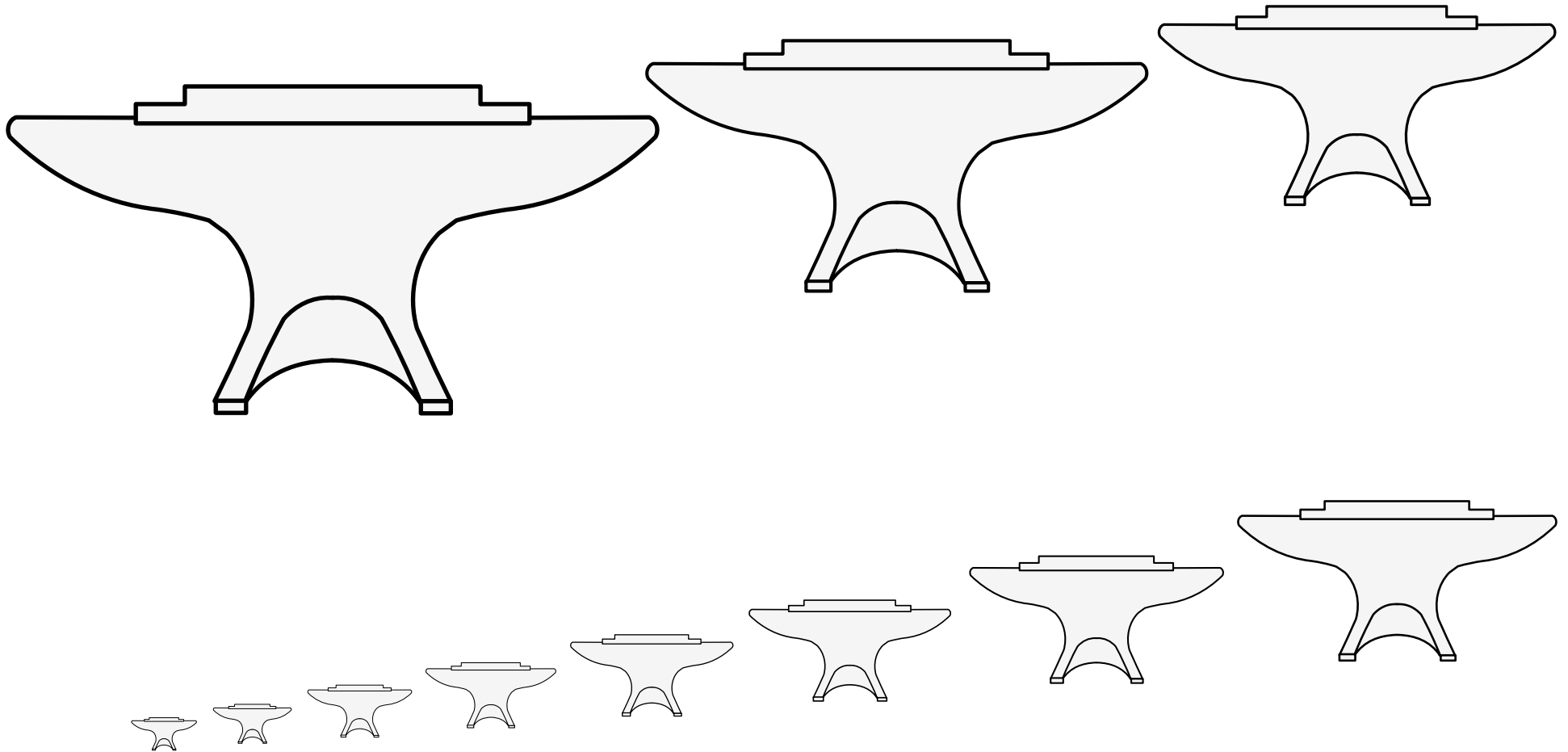

A solid base used for shaping metal.

Default orientation: flat surface to chief. No proper coloration.

Source: Viking Answer Lady SVG Images For Heralds. Artist: Gunnvôr silfrhárr. Adapted by Mathghamhain Ua Ruadháin.

Anvil, Two-horned (2) 16.15

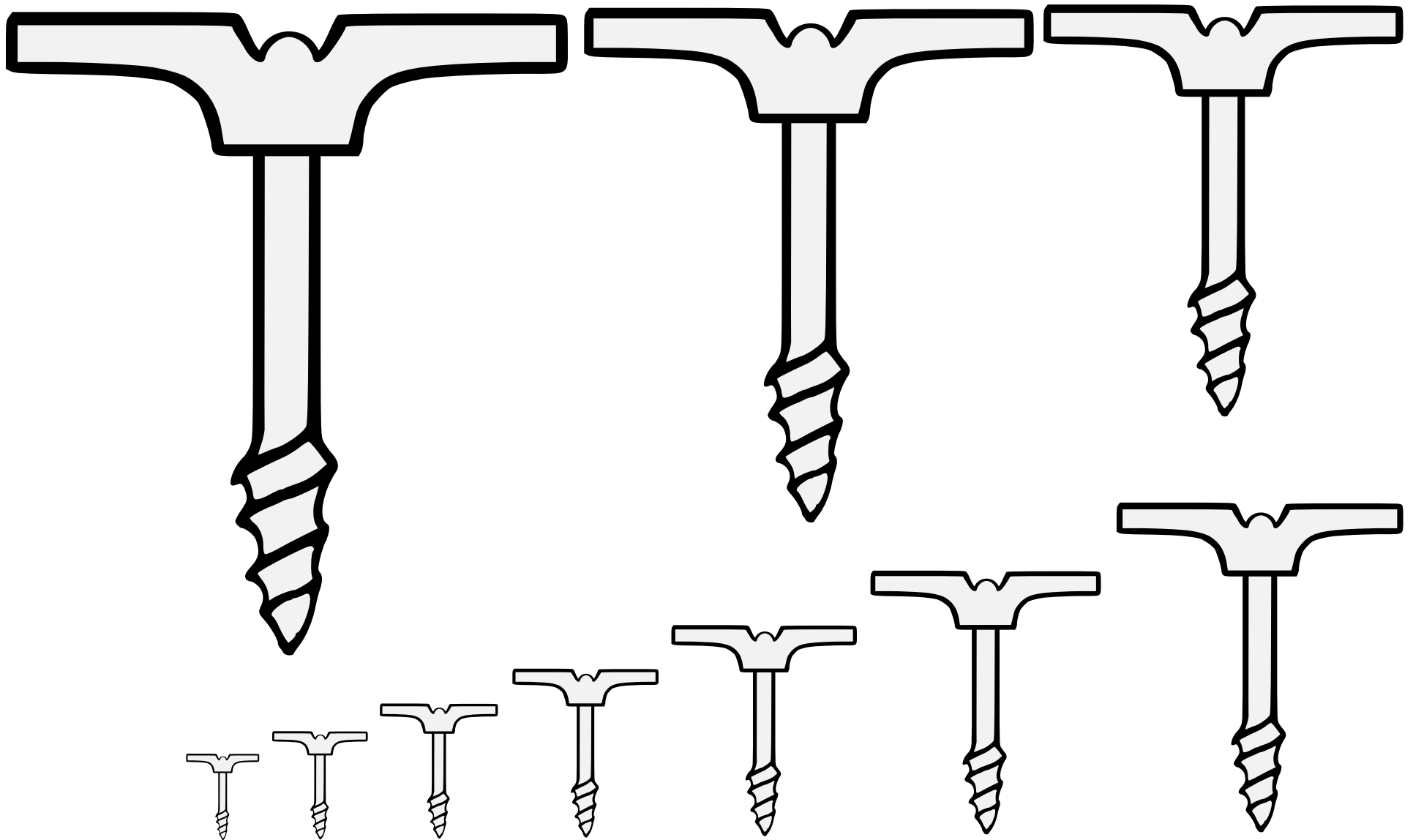

A tool for making holes.

Default orientation: upright. No proper coloration.

Source: Wappenbuch der Arlberg-Bruderschaft. Artist: Vigil Raber.
Adapted by Jessimond of Emerickeskepe.

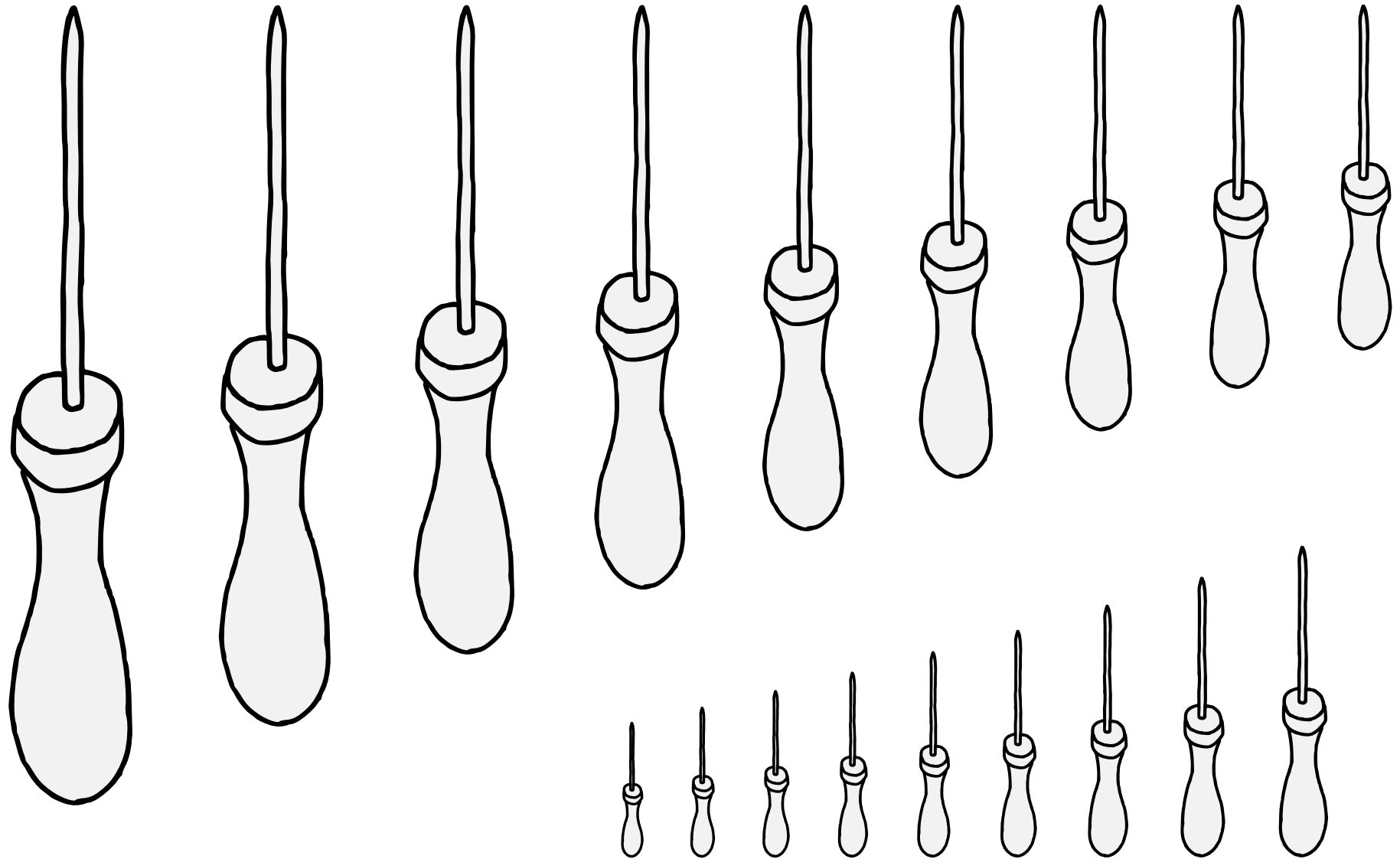

A tool for making holes.
Default orientation: point to chief.
Source: Pennsic Bored-Artist Collection. Artist unknown.



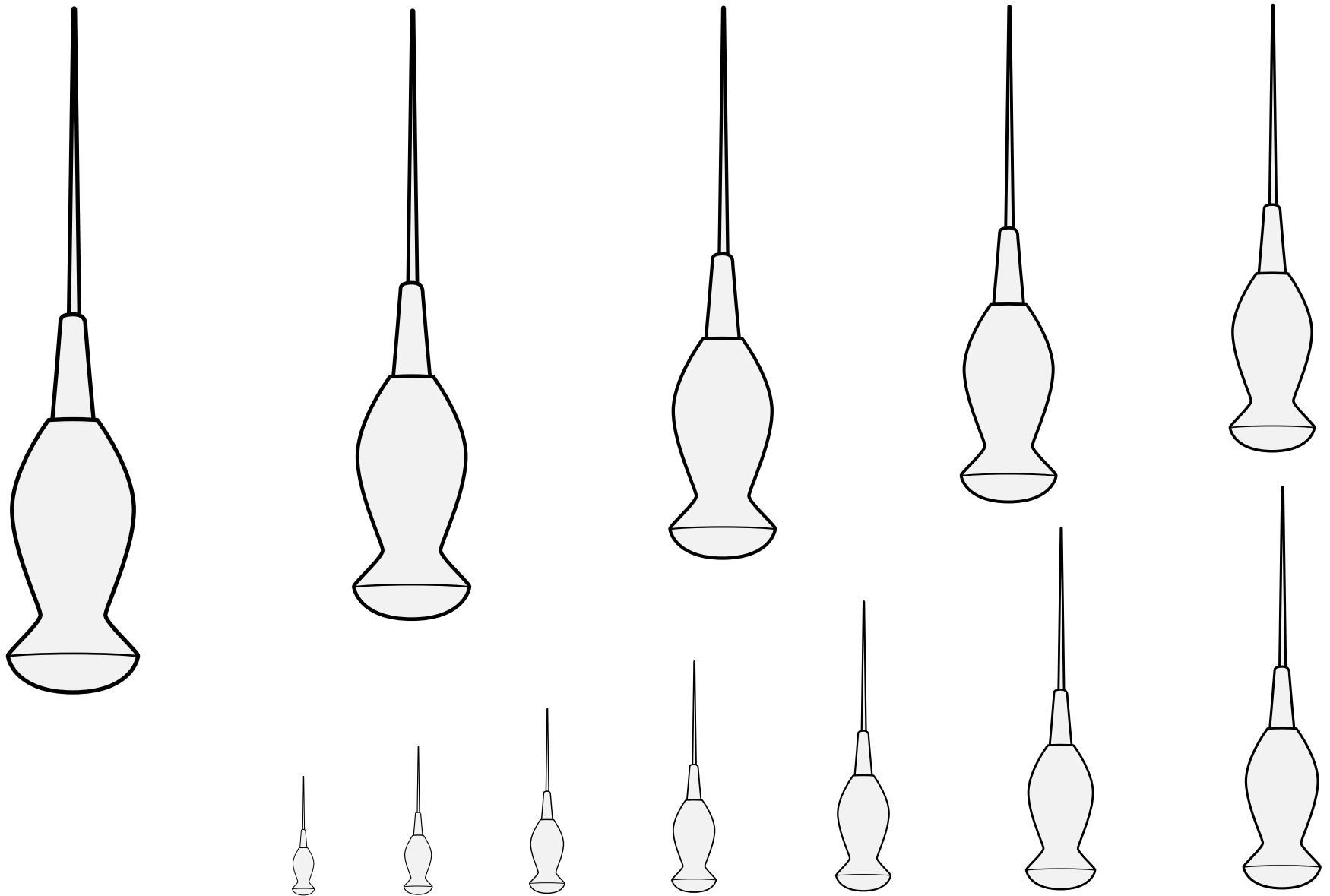

A tool for making holes.
Default orientation: point to chief.

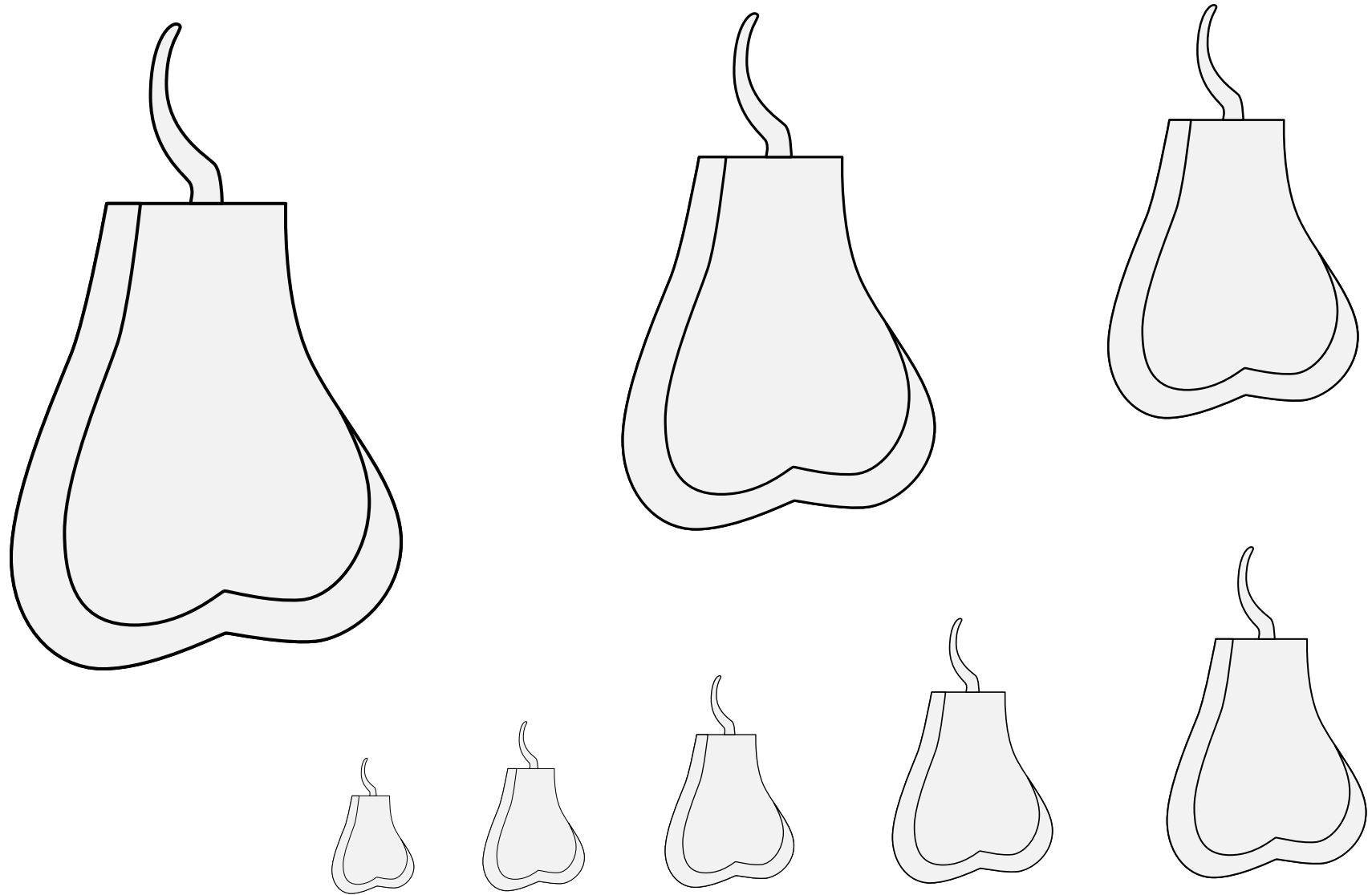

A tool for making holes.

Default orientation: point to chief.

Source: Nobiliario de Armas de Valencia, Aragón y Cataluña.
Artist unknown. (Folio 28v.)

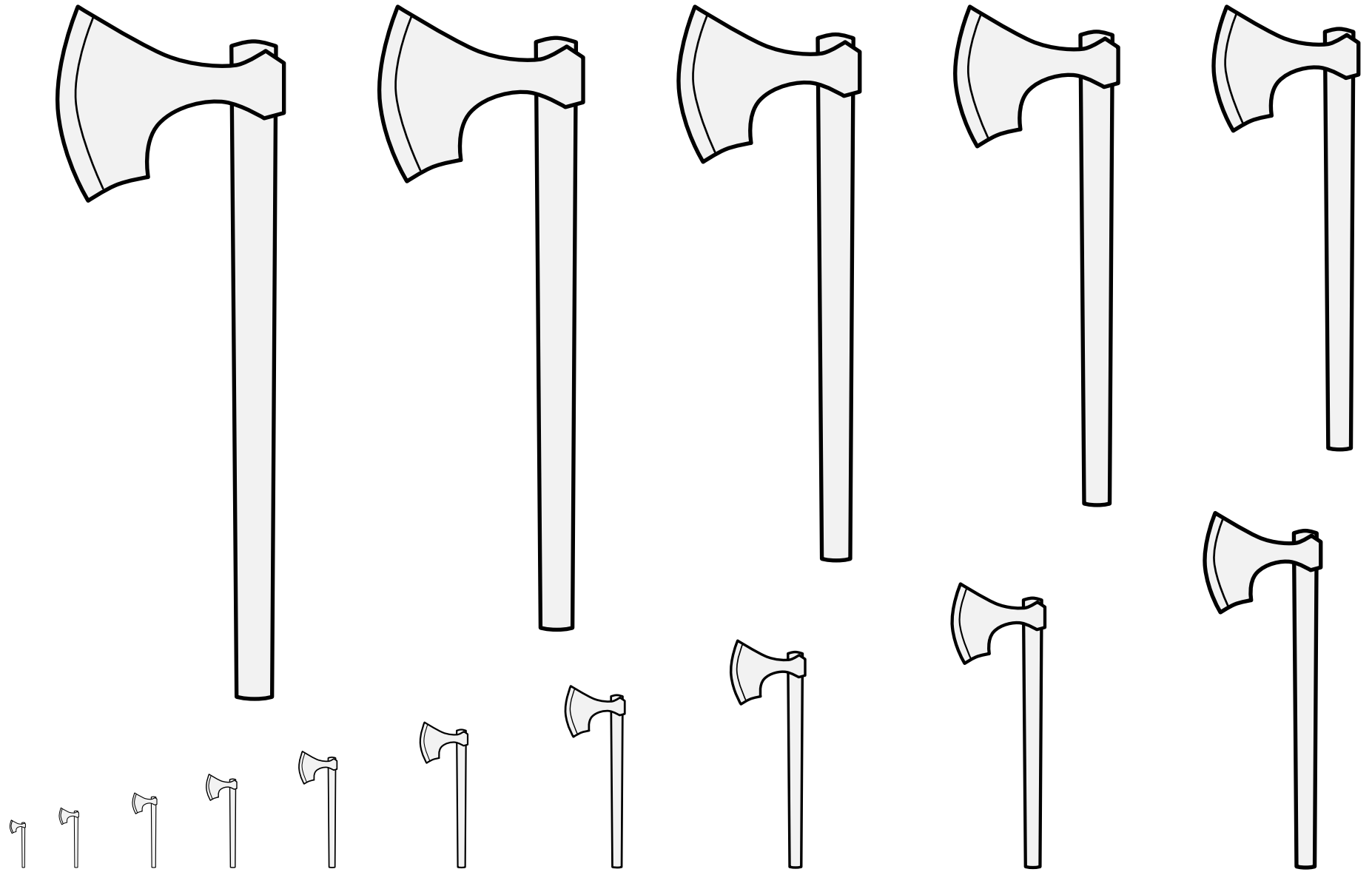

A tool for cutting wood.
Default orientation: handle to base, blade to dexter.

Axe (1) 16.20

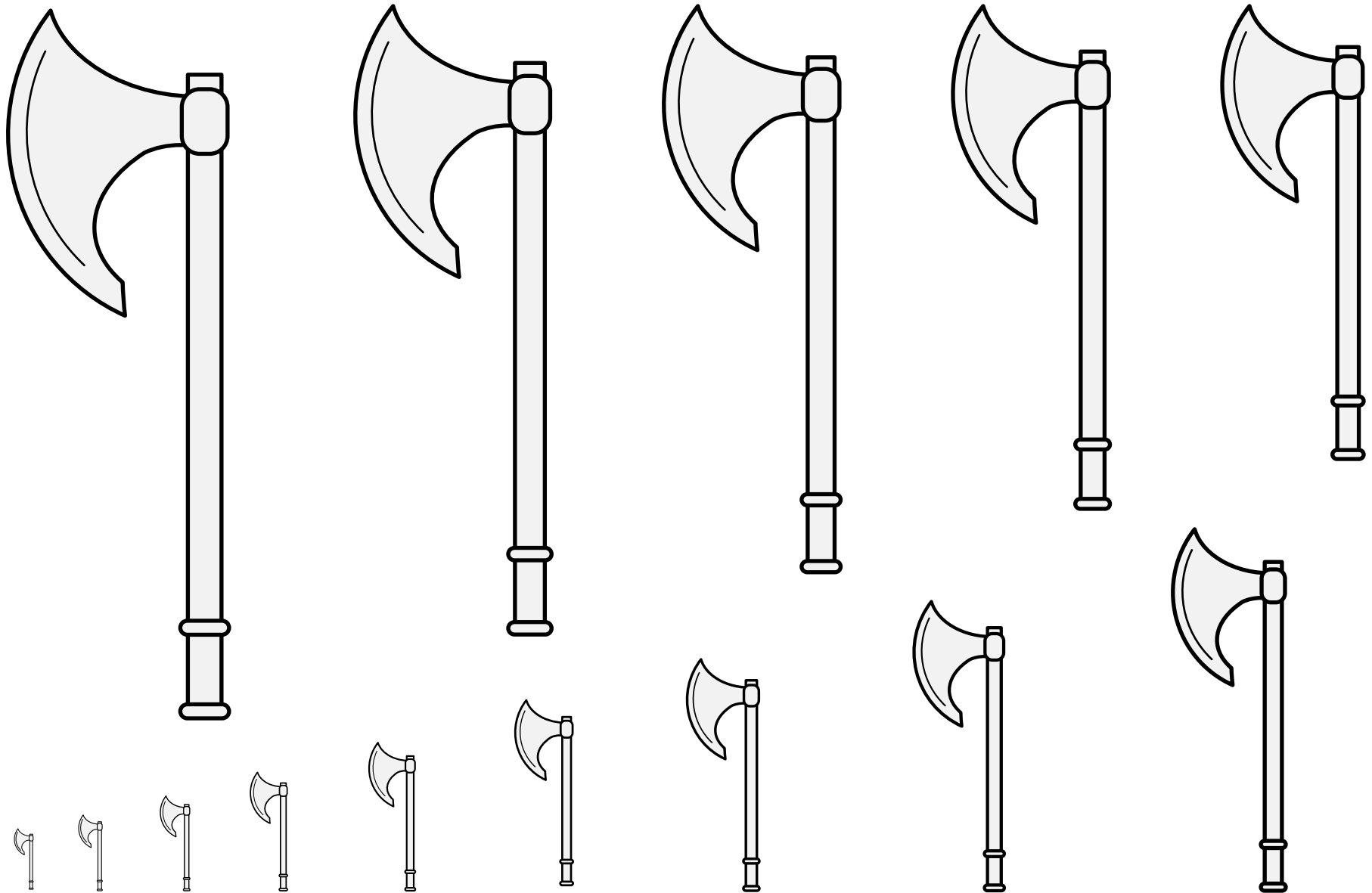

A tool for cutting wood.

Default orientation: handle to base, blade to dexter.

Source: Viking Answer Lady SVG Images For Heraldists. Artist: Gunnvôr silfráhr.

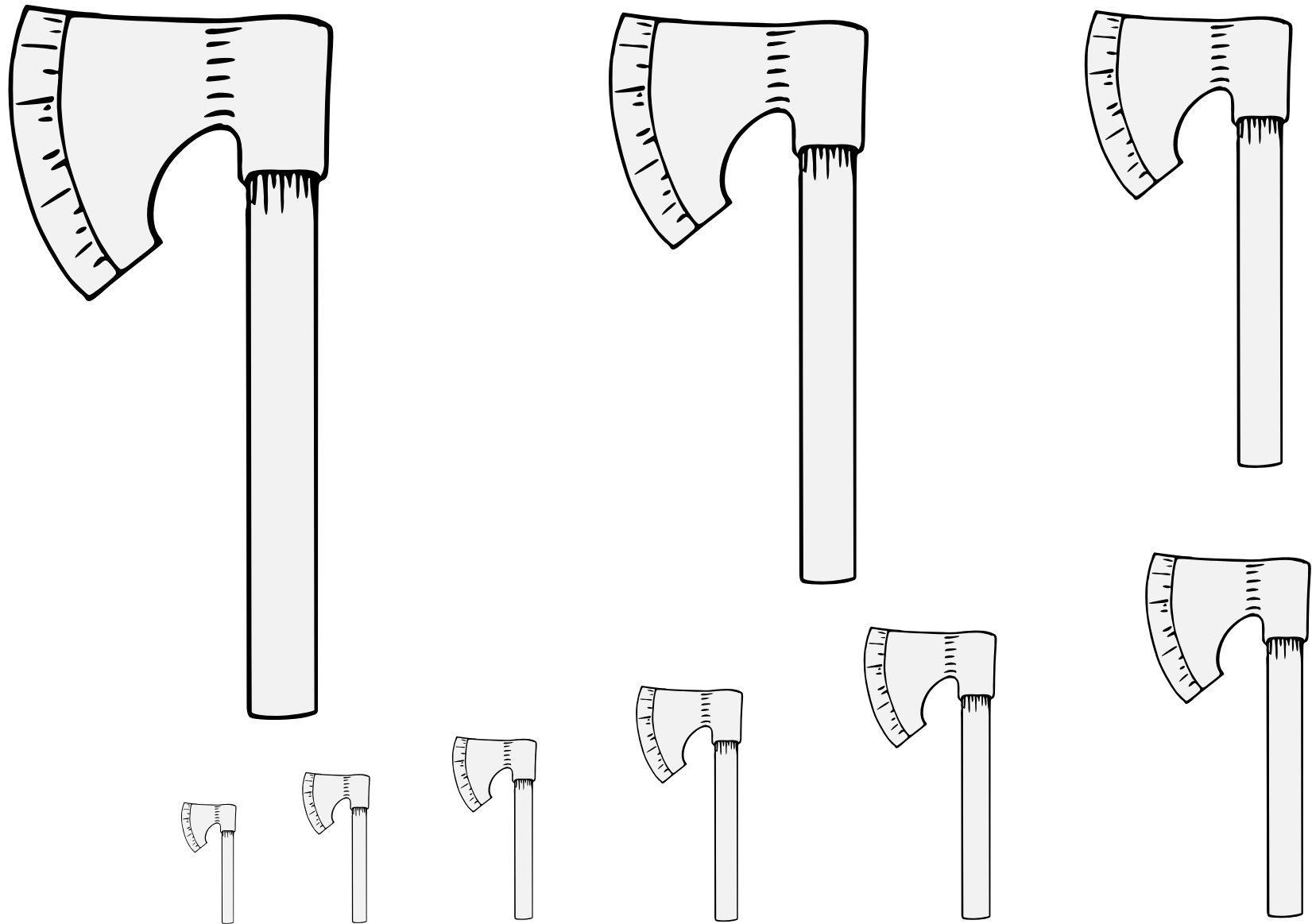

A tool for cutting wood.

Default orientation: palewise, blade to dexter chief.

Source: Heraldic Templates. Artist: Torric inn Björn.

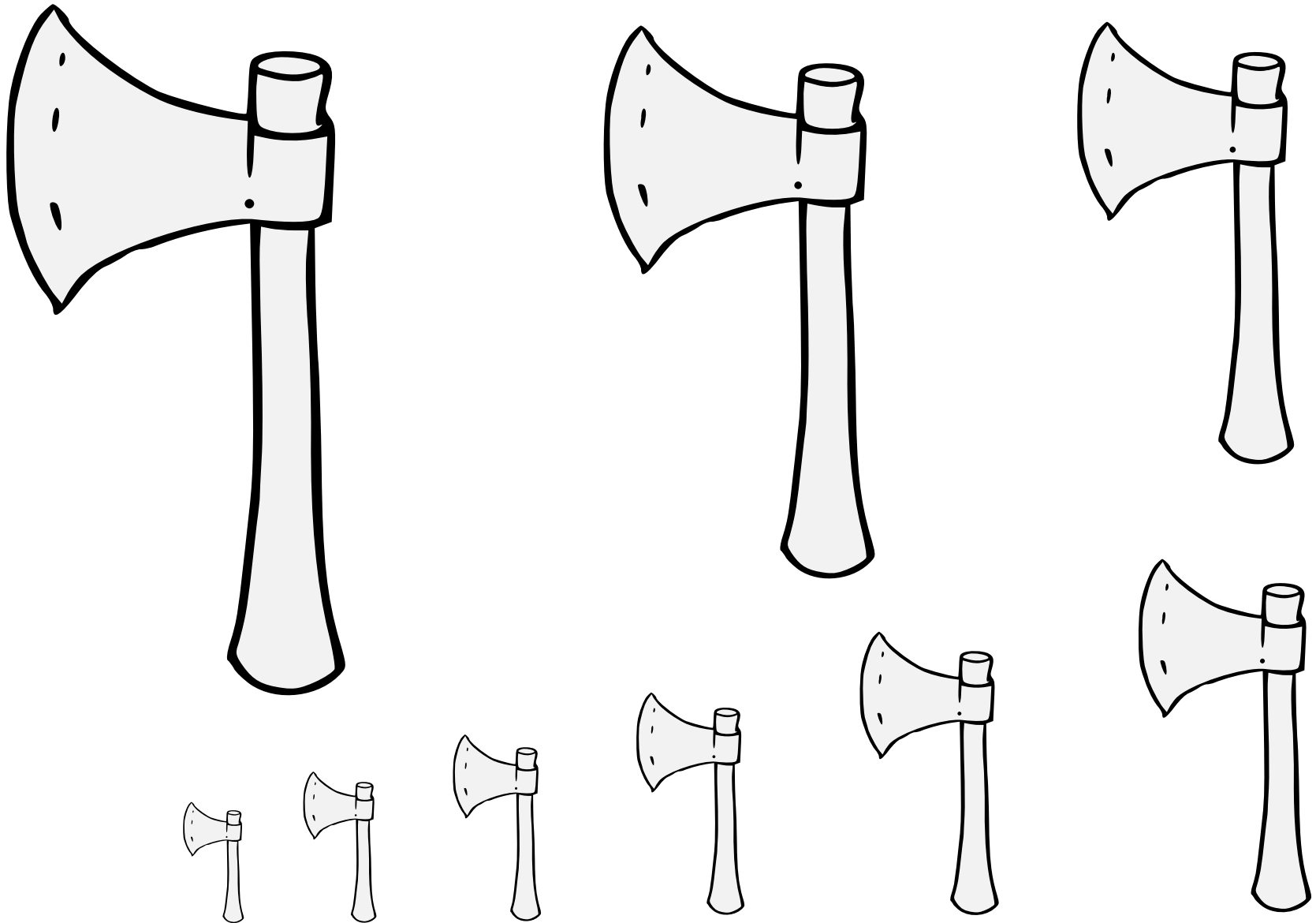

A sharp blade attached to a wooden shaft. A short-handled axe such as this may be blazoned a hatchet.

Default orientation: handle to base, blade to dexter.

Source: Pennsic Traceable Art. Artist unknown.

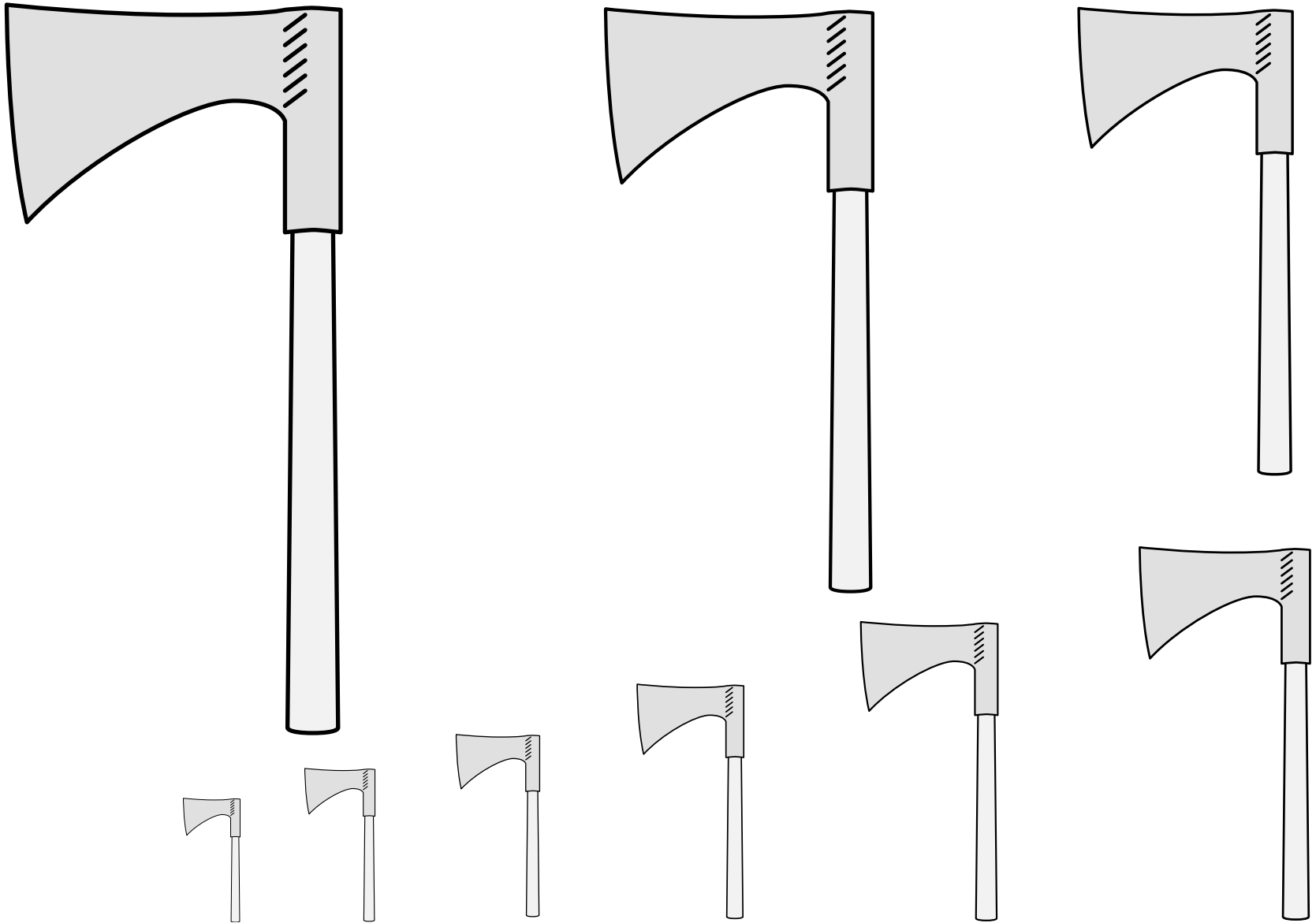

A sharp blade attached to a wooden shaft. A short-handled axe such as this may be blazoned a hatchet.

Default orientation: handle to base, blade to dexter.

Source: Livro de Nobreza. Artist: António Godinho.
(Arms of Machado, folio 35v.)

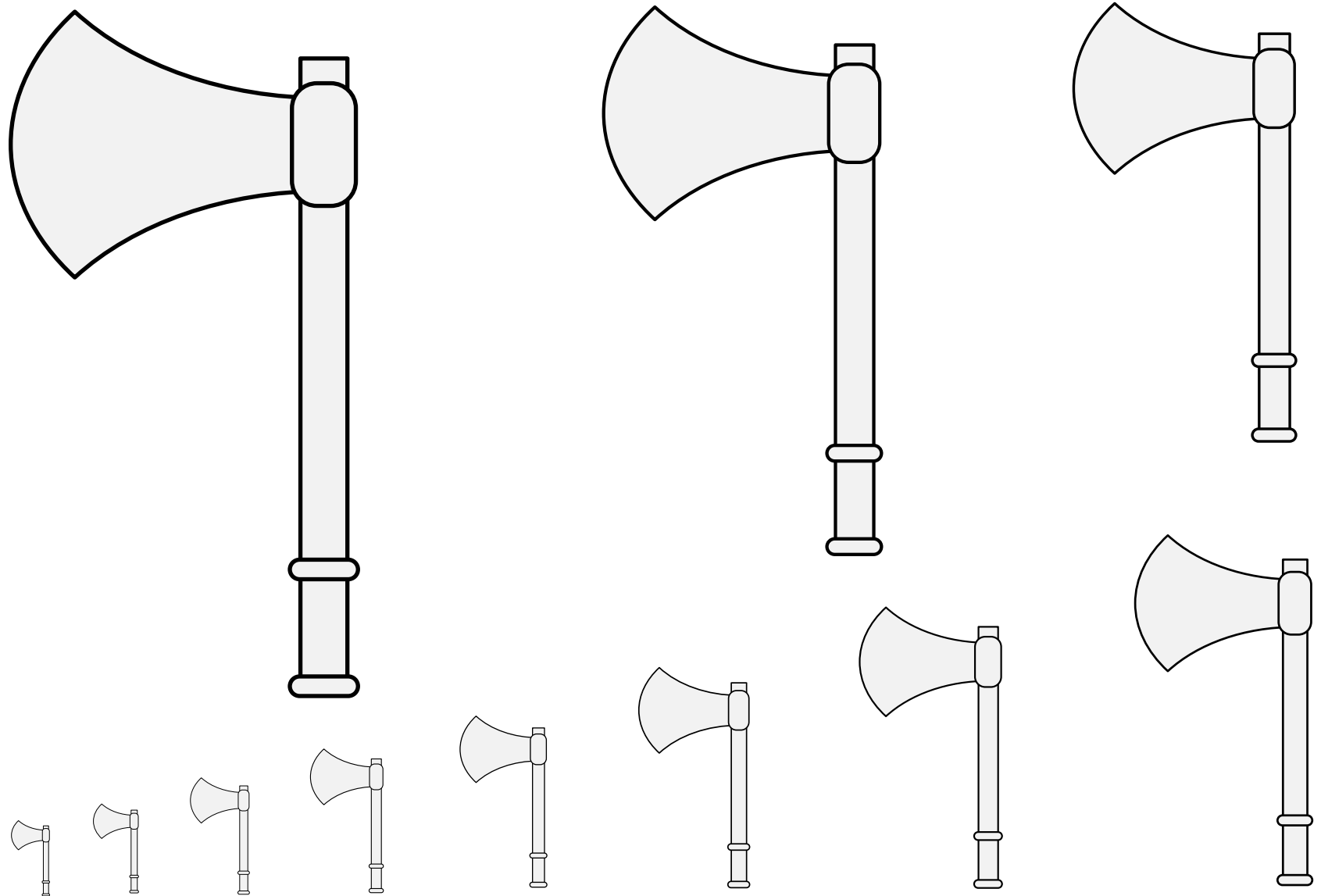

A tool for cutting wood.

Default orientation: handle to base, blade to dexter.

Source: Viking Answer Lady SVG Images For Heraldry. Artist: Gunnvôr silfráhr.

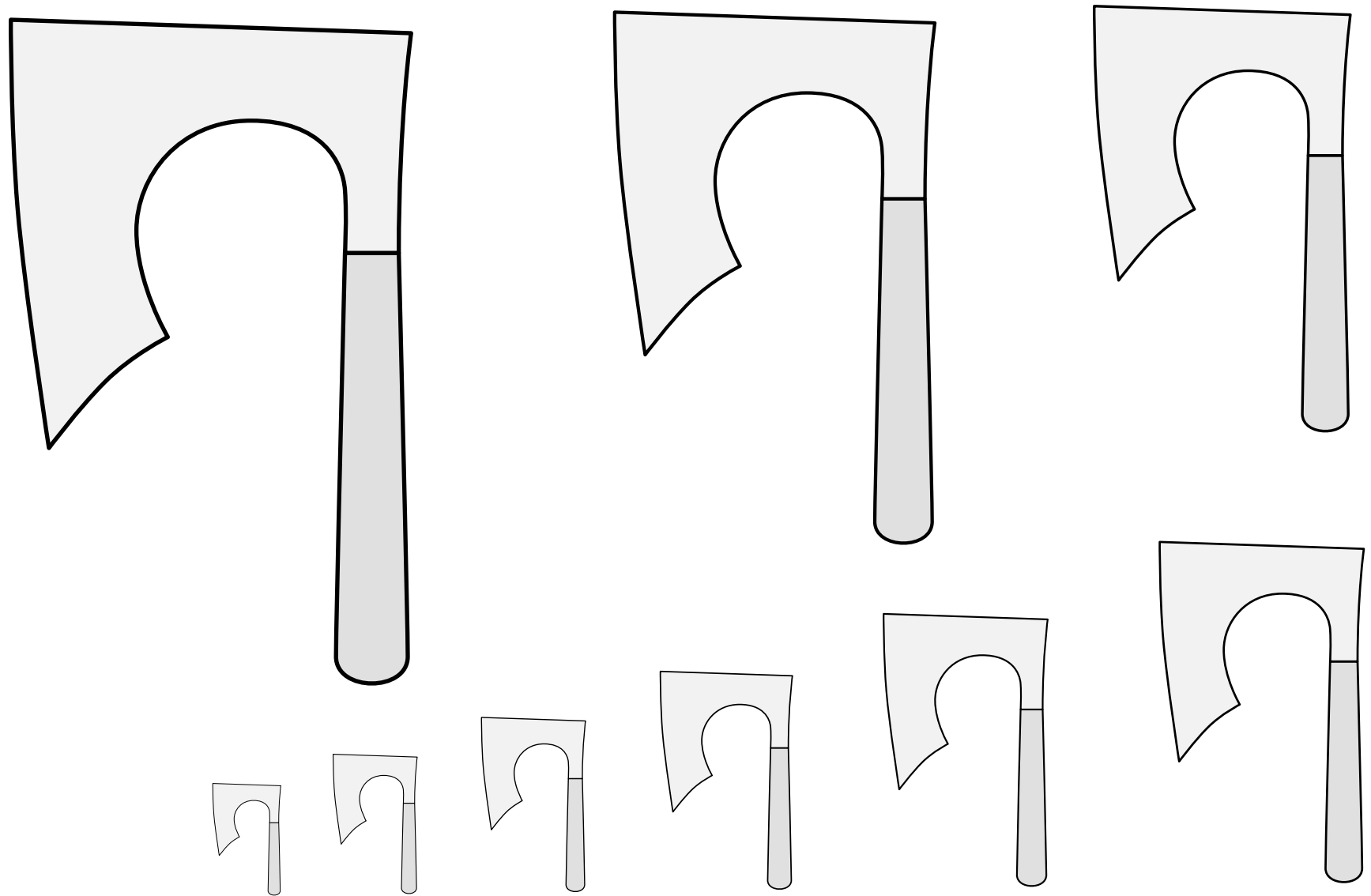

A tool for cutting wood.

Default orientation: handle to base, blade to dexter.

Source: BnF MS Allemand 304. Artist unknown. (Page 731.)

Axe (7) 16.26

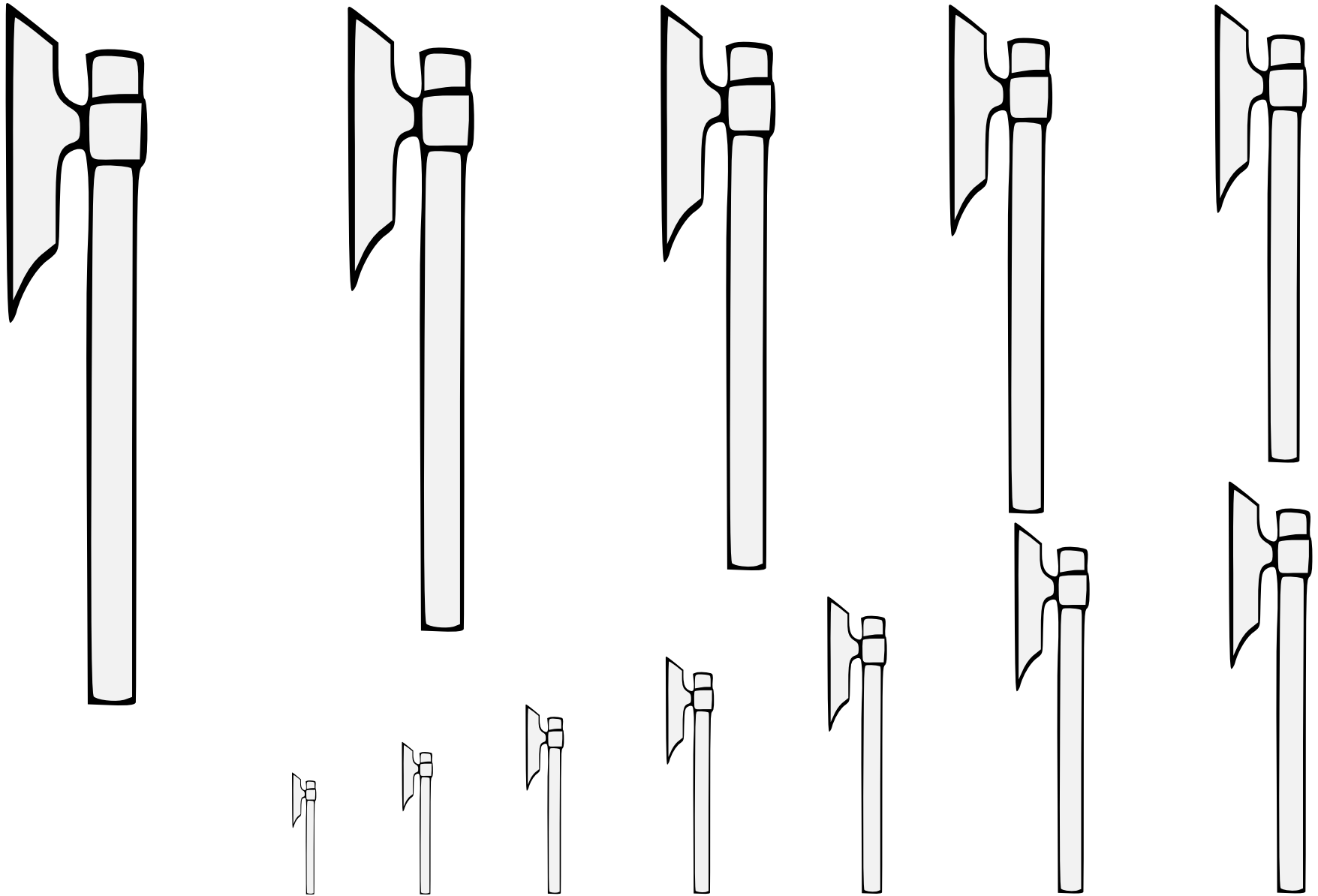

A sharp blade attached to a wooden shaft. A broad axe has a straight edge used for carpentry.

Default orientation: handle to base, blade to dexter.

Source: Pennsic Traceable Art. Artist unknown.

Axe, Broad (1) 16.27

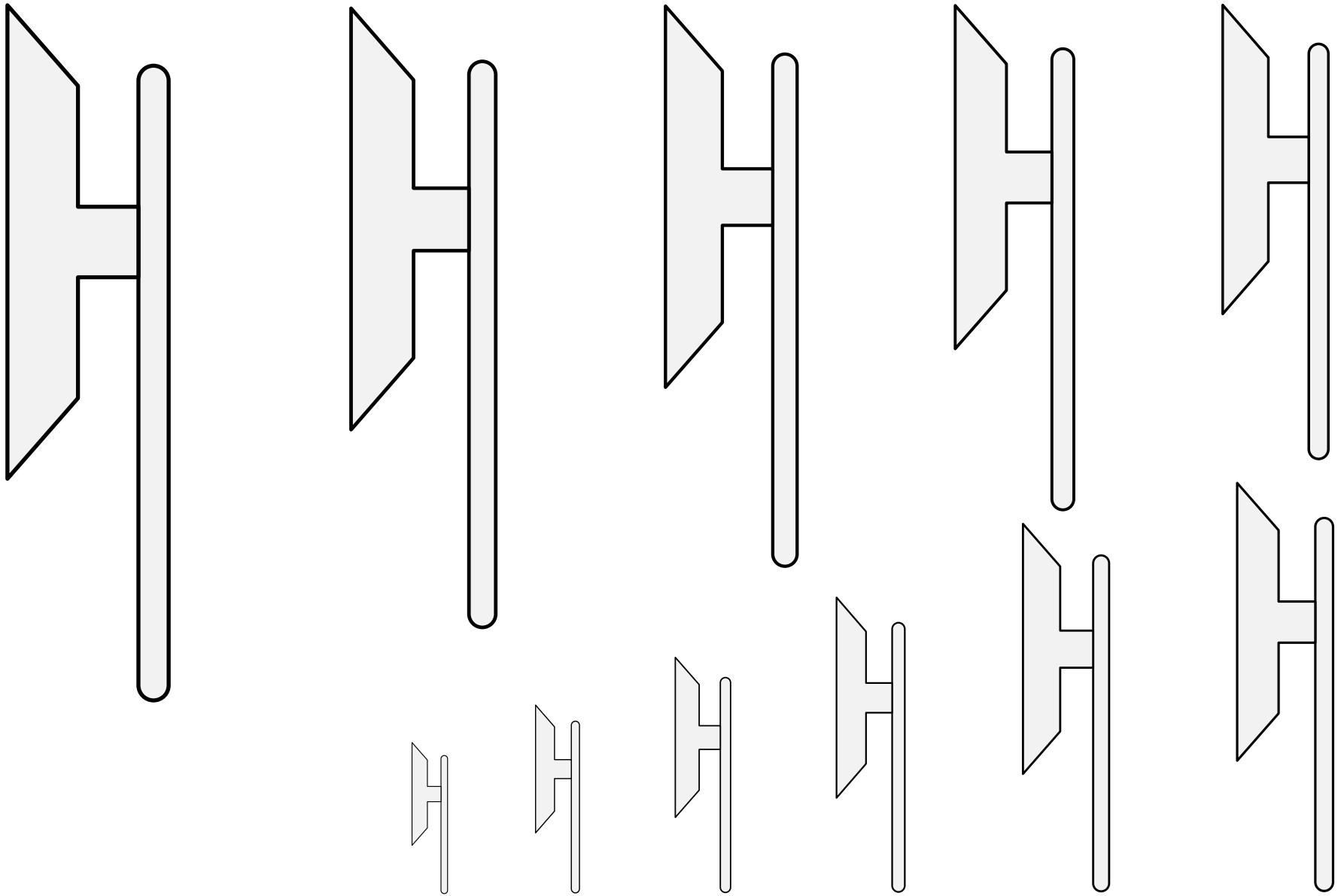

A sharp blade attached to a wooden shaft. A broad axe has a straight edge used for carpentry.

Default orientation: handle to base, blade to dexter.

Source: Heiligen Römischen Reiches. Artist unknown. (Page 913.)

Axe, Broad (2) 16.28

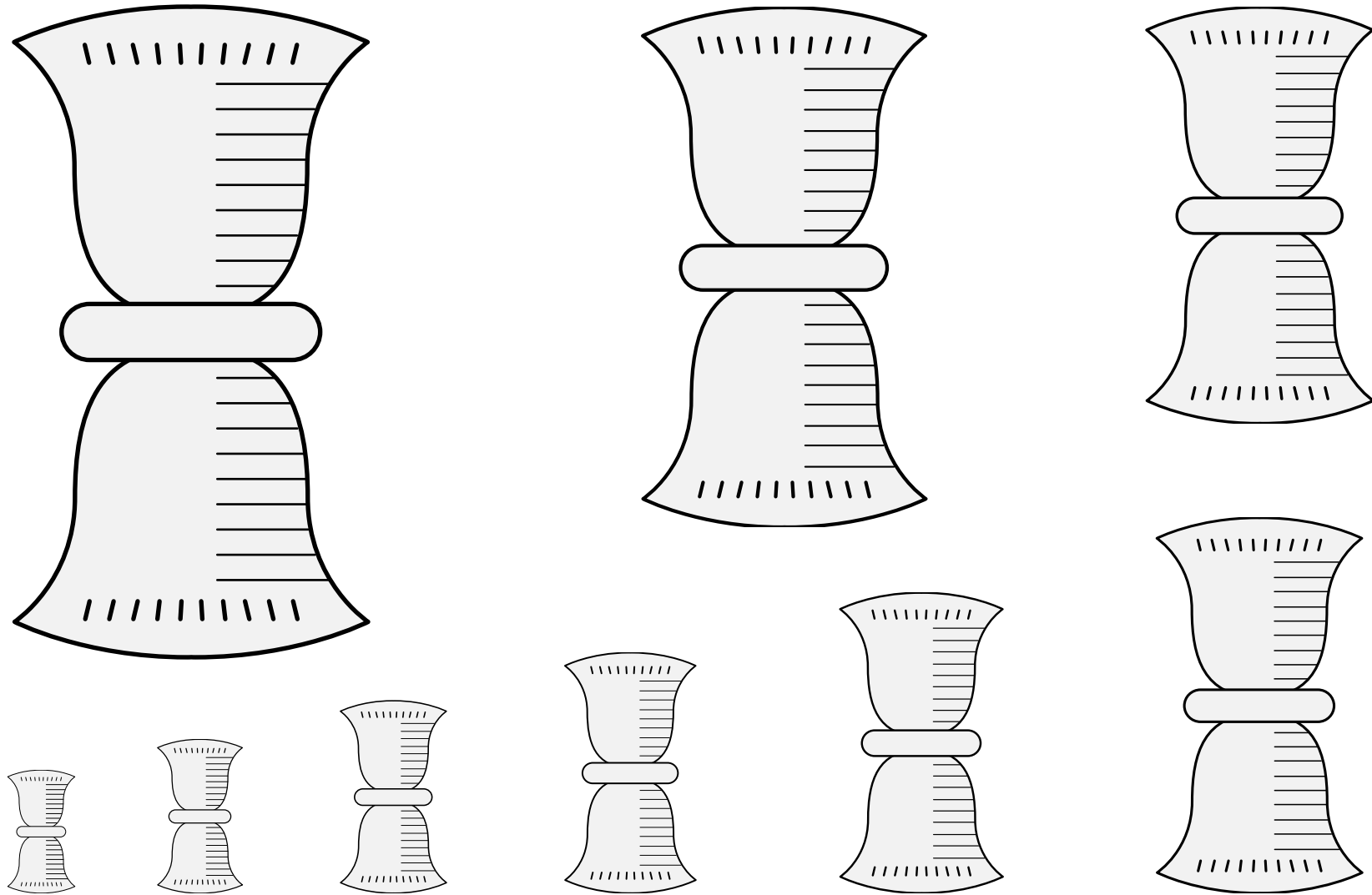

A sharp blade attached to a wooden shaft. The chipping axe is a specialized form used to shape stonework.

Default orientation: blades to base and chief. No proper coloration.

Source: The Armes of All the Cheife Corporatons.
Artist unknown. (From the arms of the Marblers.)

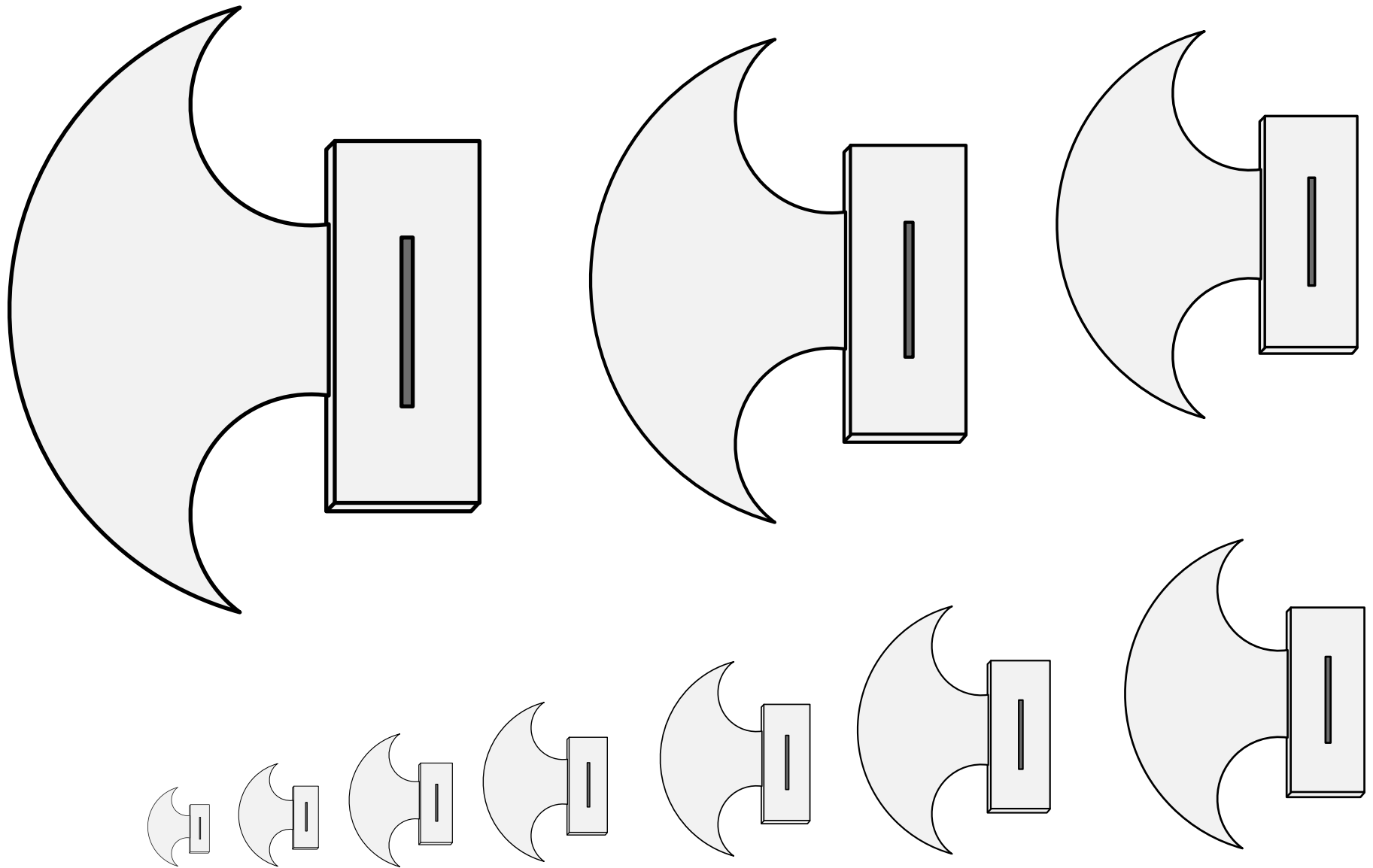

The head of an axe.

Default orientation: blade to dexter. No proper coloration.

Source: Siebmacher's Wappenbuch of 1605. Artist: Johann Siebmacher.
(Arms of von Franckenstein.)

Axe-Head (1) 16.30

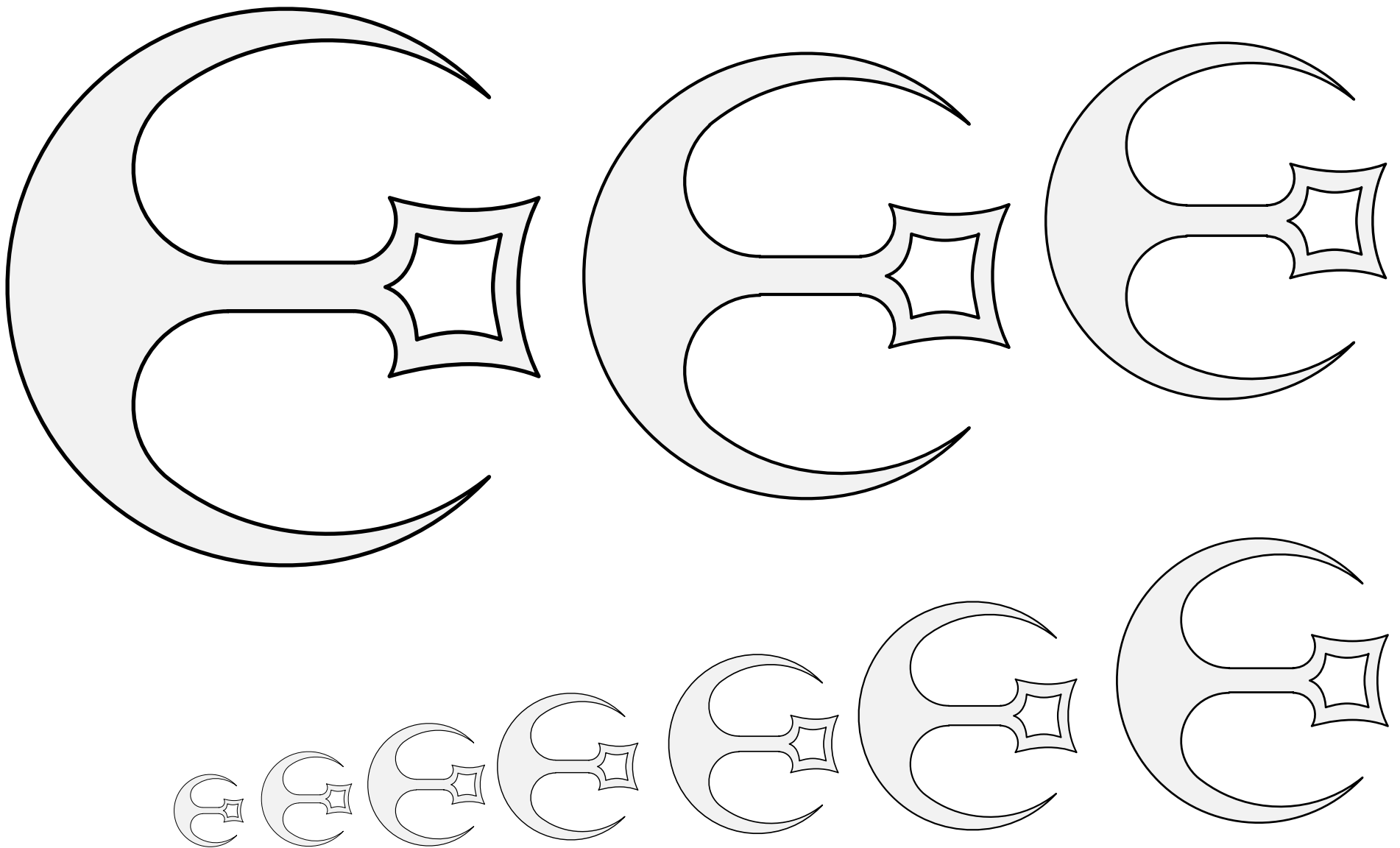

The head of an axe.

Default orientation: blade to dexter. No proper coloration.

Source: Scheibler Armorial. Artist: Unknown.
(Arms of von Franckenstein.)

Axe-Head (2) 16.31

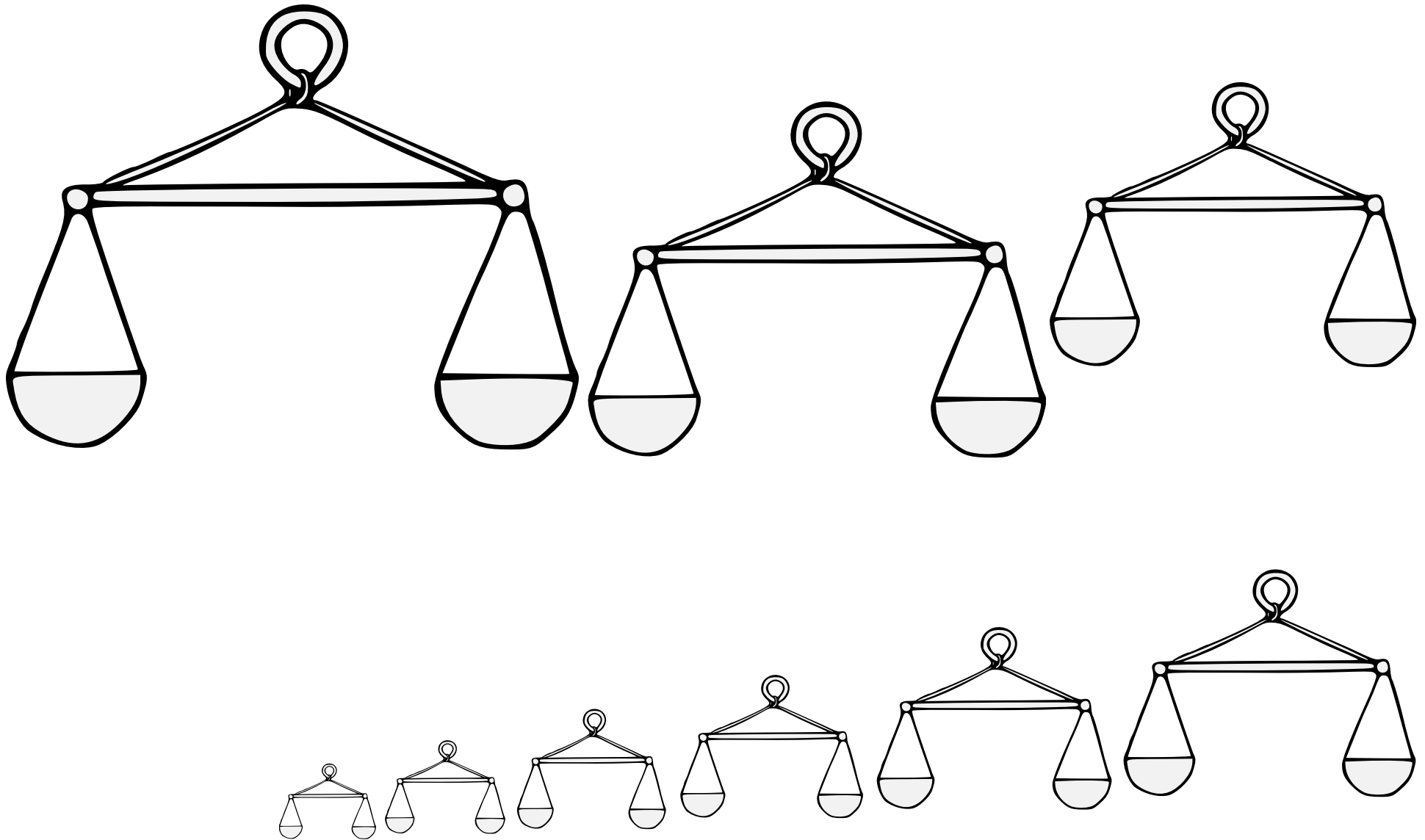

A mechanism for comparing weights.

Default orientation: fesswise. No proper coloration.

Source: Pennsic Traceable Art. Artist: Hrefna in hepna.

Balance, Hanging (1) 16.32

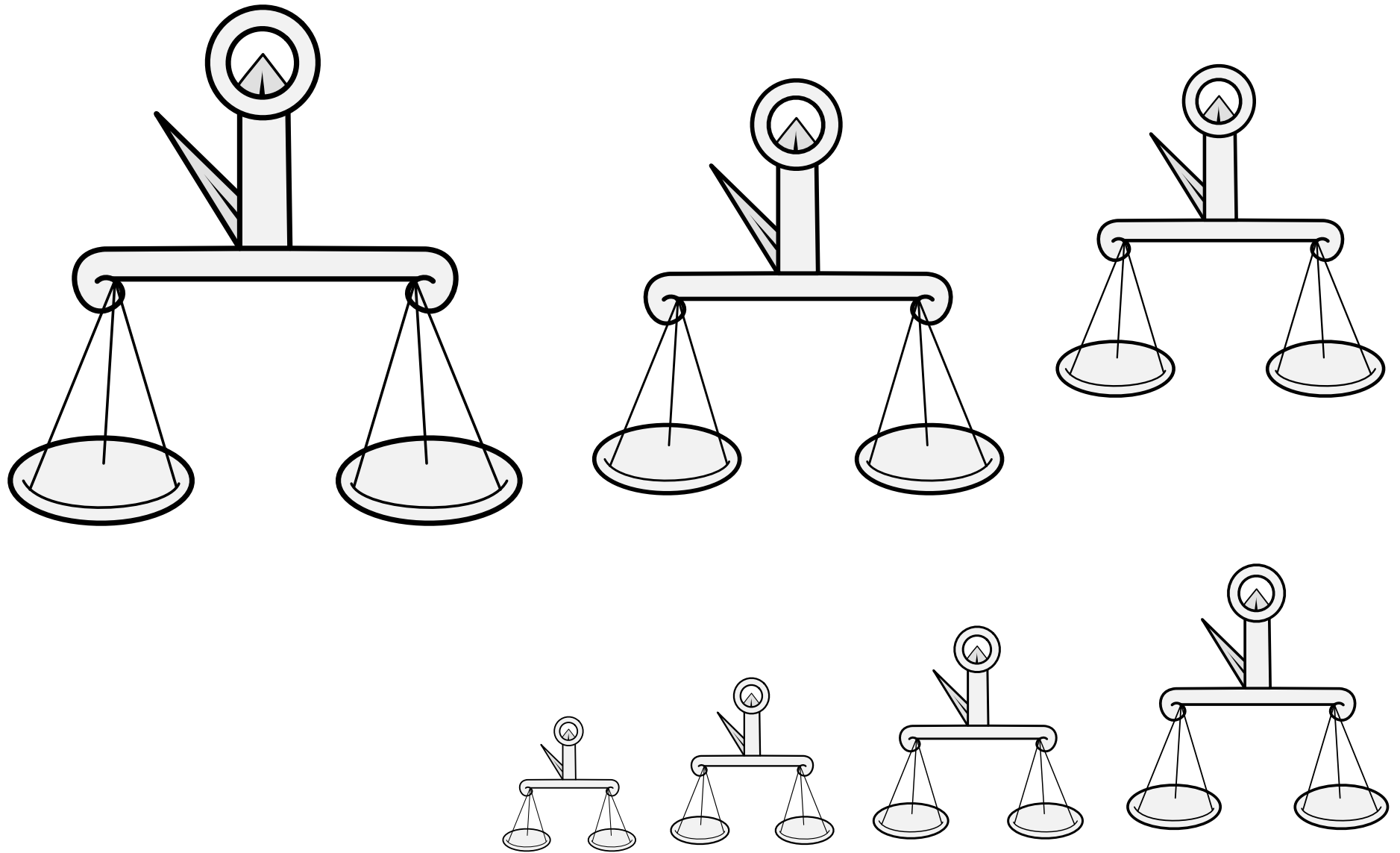

A mechanism for comparing weights.

Default orientation: fesswise. No proper coloration.

Artist: Jon Cheseby. Adapted from Workes of Armorie.

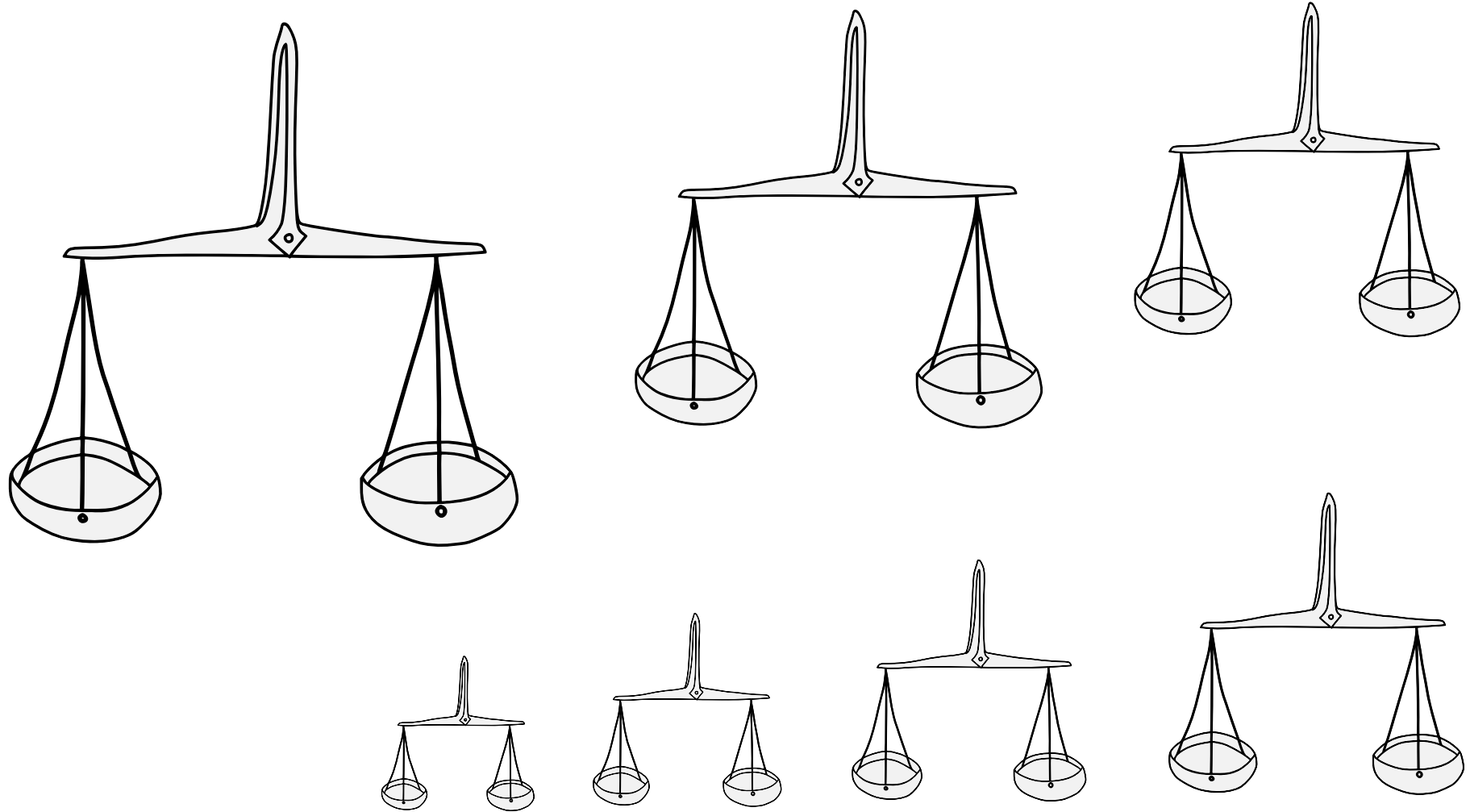

A mechanism for comparing weights.

Default orientation: fesswise. No proper coloration.

Source: The Tudor Pattern Book. Artist unknown.

Adapted by Owen Tegg.

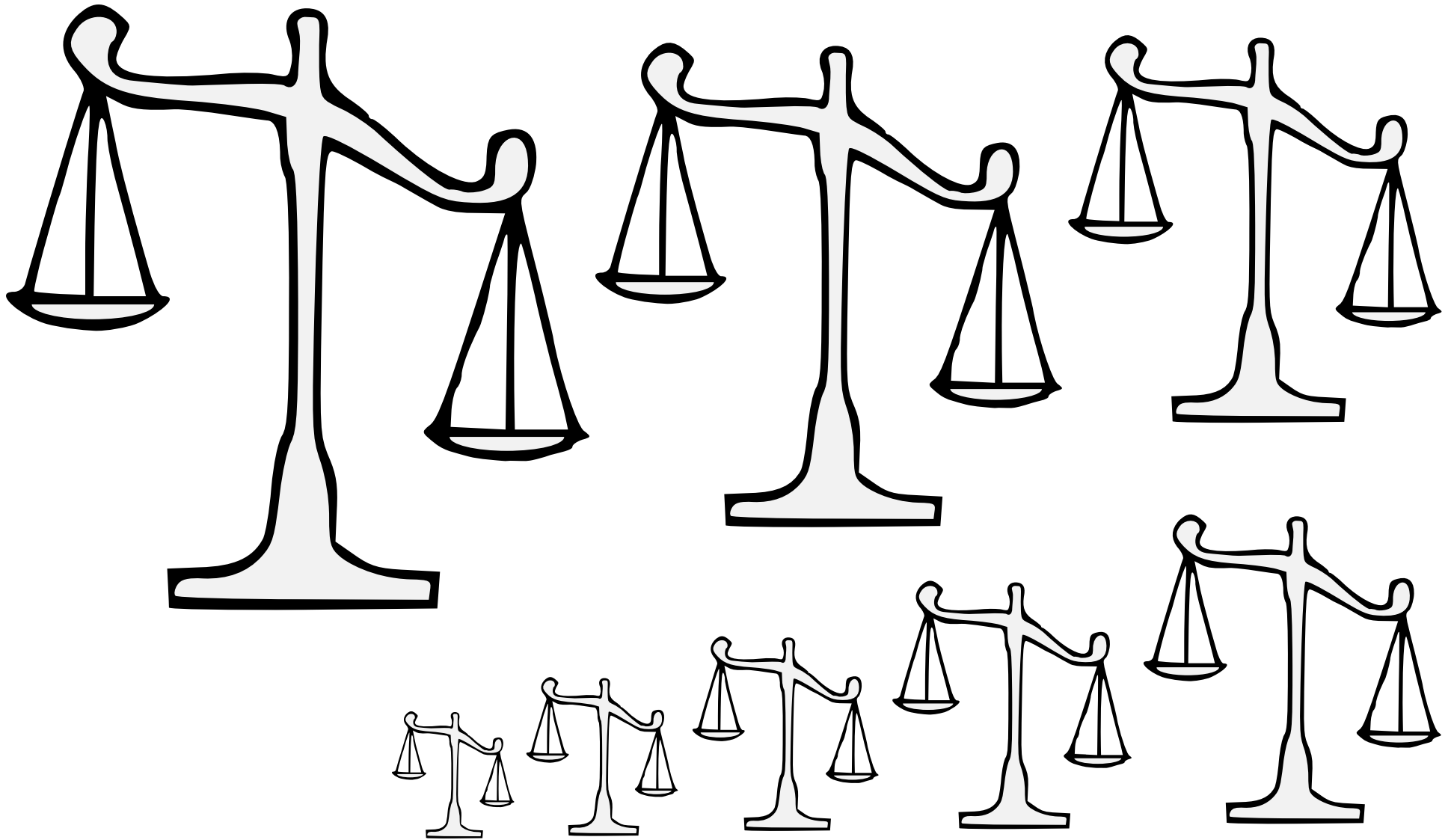

A mechanism for comparing weights.

Default orientation: upright. No proper coloration.

Standing balances were very uncommon in period, used only for measuring tiny gems and precious metals; this form has been disallowed pending further documentation as of the November 2012 LoAR.

Source: Pennsic Traceable Art. Artist: Unknown.

Balance, Standing 16.35

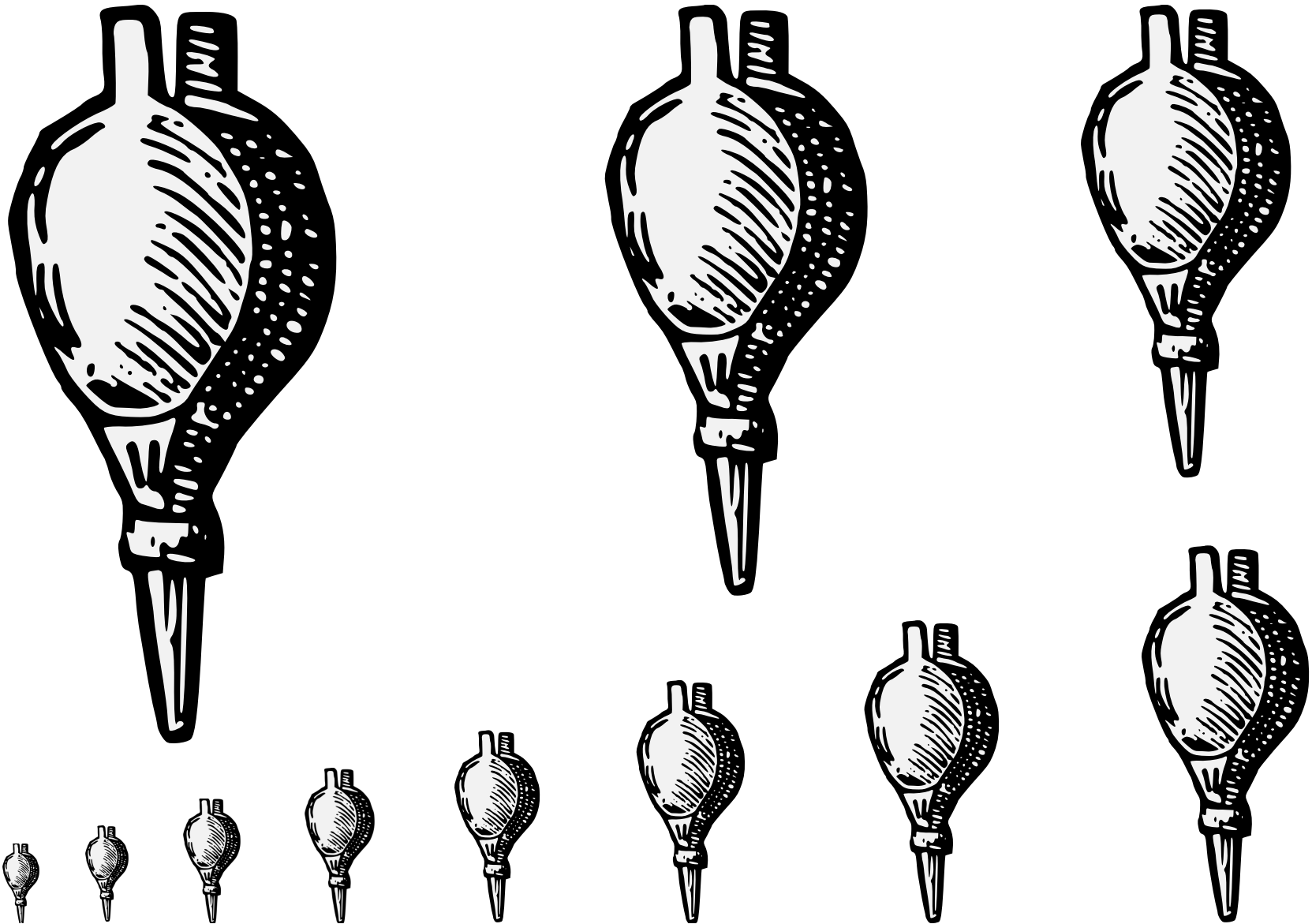

A device for pumping air, typically used to stoke fires or forges.

Default orientation: spout to base. No proper coloration.

Source: Guillim's Display of Heraldry. Artist unknown.

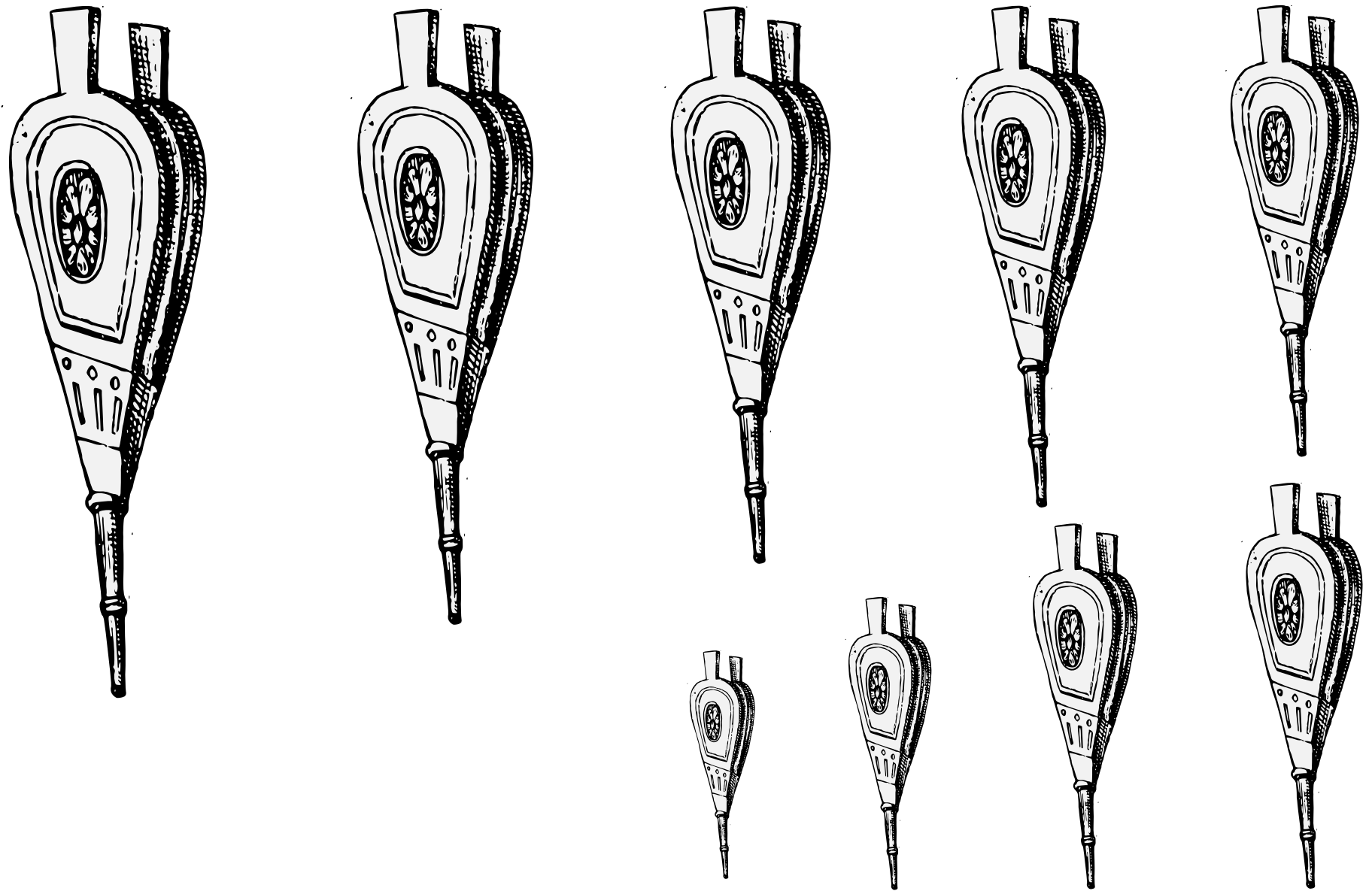

A device for pumping air, typically used to stoke fires or forges.

Default orientation: spout to base. No proper coloration.

Source: Opera Dell'arte Del Cucinare. Artist unknown. (Page 966.)

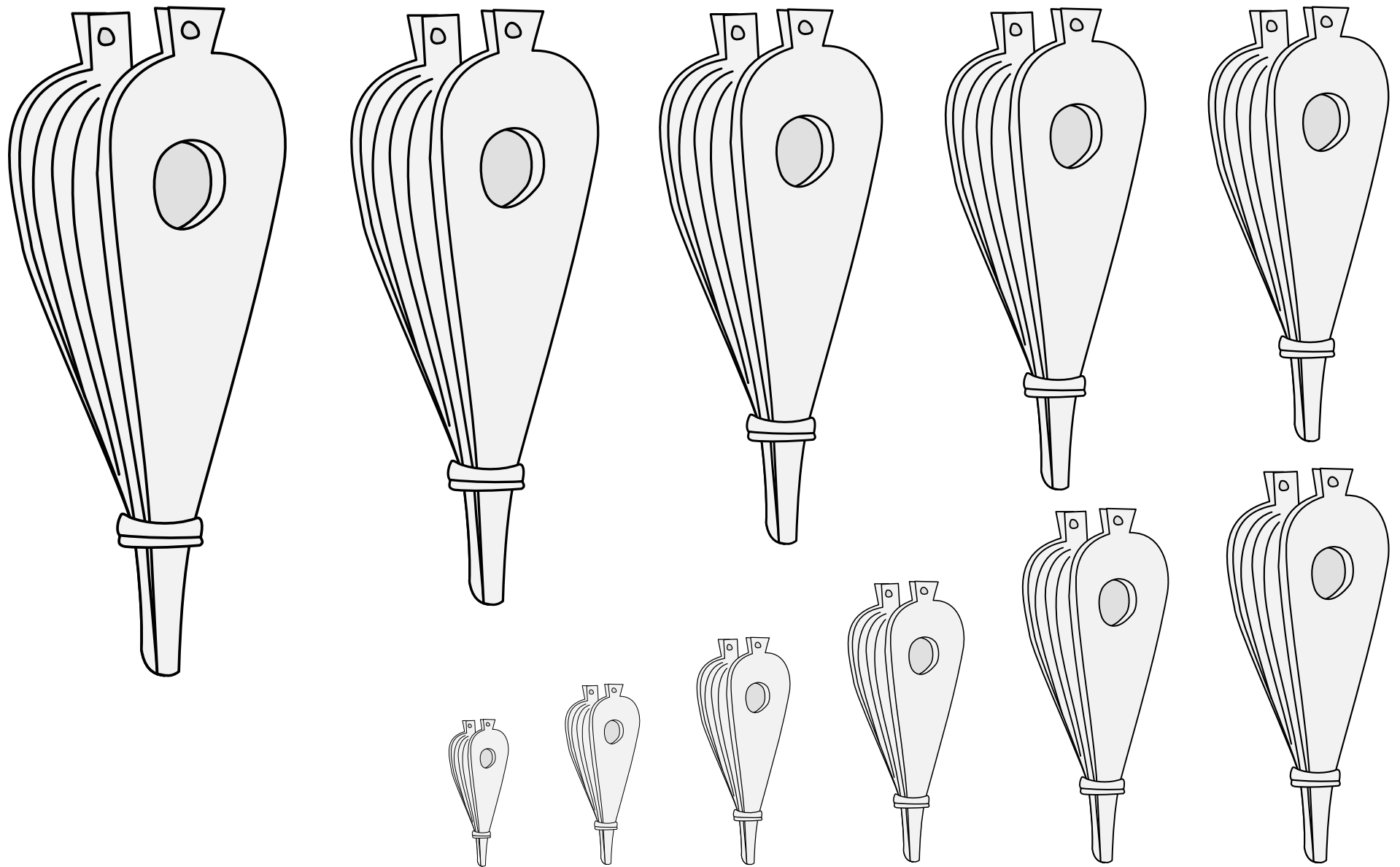

A device for pumping air, typically used to stoke fires or forges.

Default orientation: spout to base. No proper coloration.

Source: Aegidius Tschudi's Armorial. Artist unknown. Adapted by Iago ab Adam.

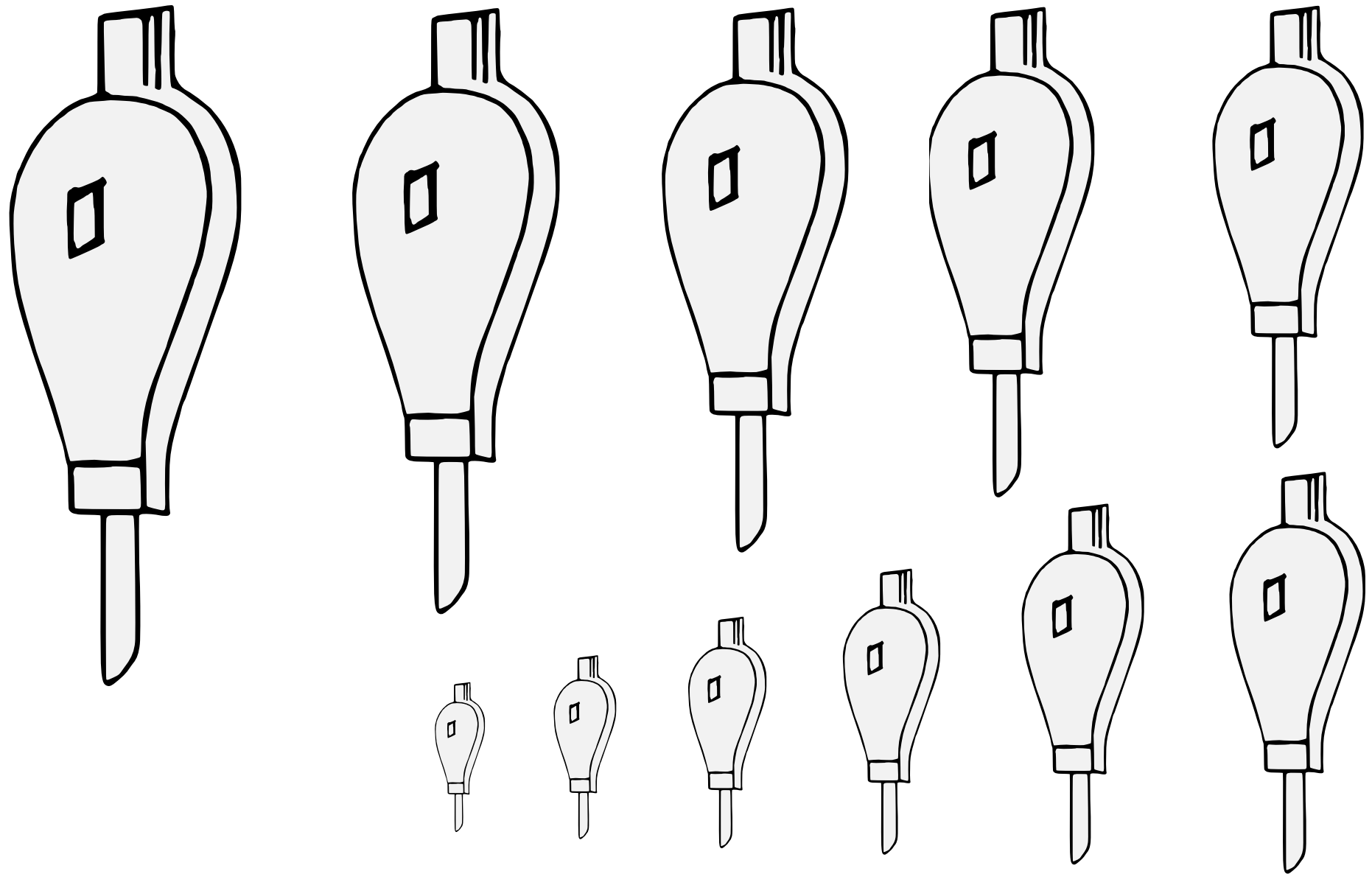

A device for pumping air, typically used to stoke fires or forges.

Default orientation: spout to base. No proper coloration.

Source: Wappenbuch der Arlberg-Bruderschaft. Artist: Vigil Raber.
(Page 833.) Adapted by Jessimond of Emerickeskepe.

Bellows (4) 16.39

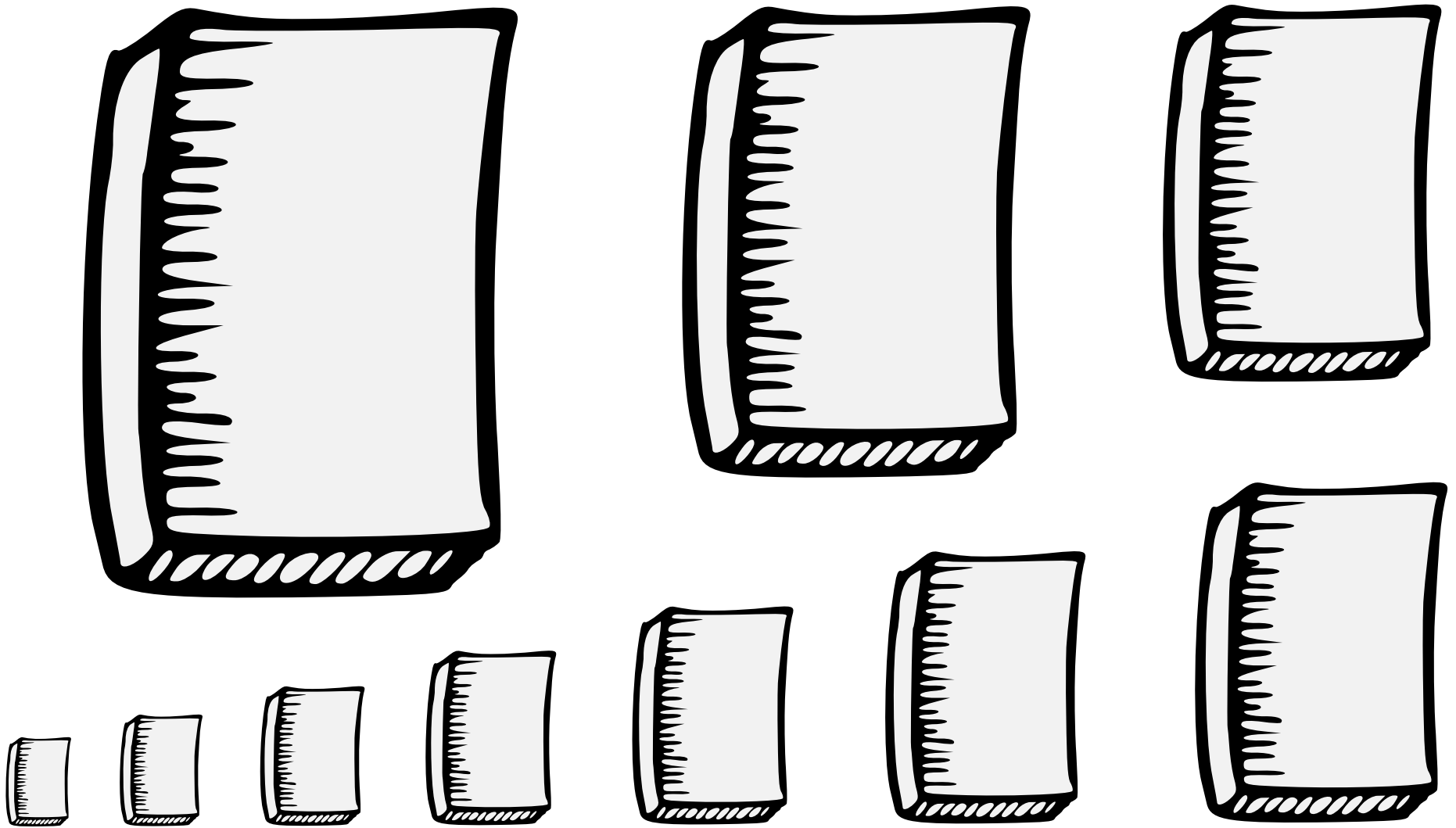

A piece of metal which has been roughly shaped.

Default orientation: upright. No proper coloration.

Source: The Armes of All the Cheife Corporatons.
Artist unknown. (From the arms of the Ironmongers.)

Billet of Iron 16.40

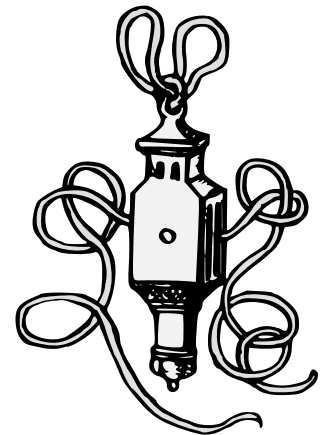
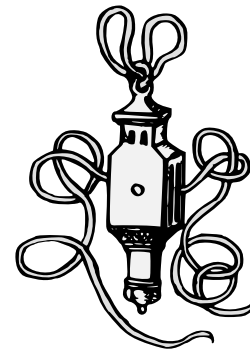
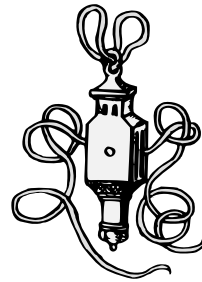
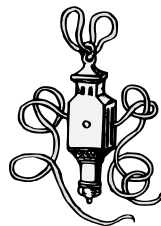
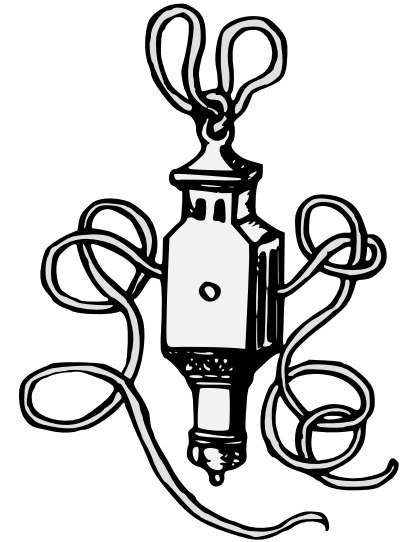
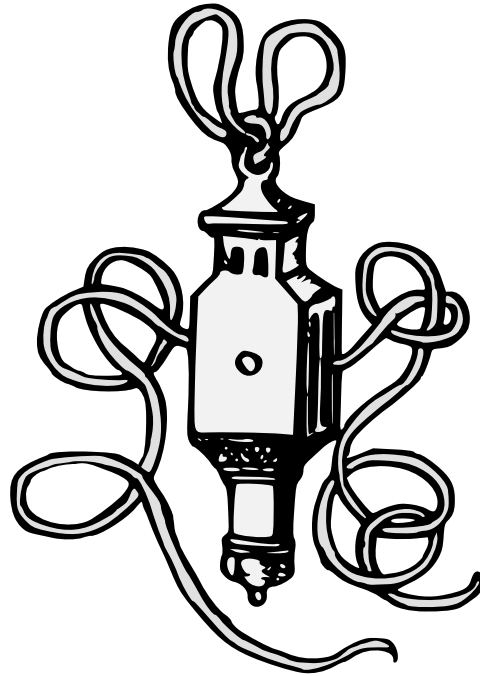
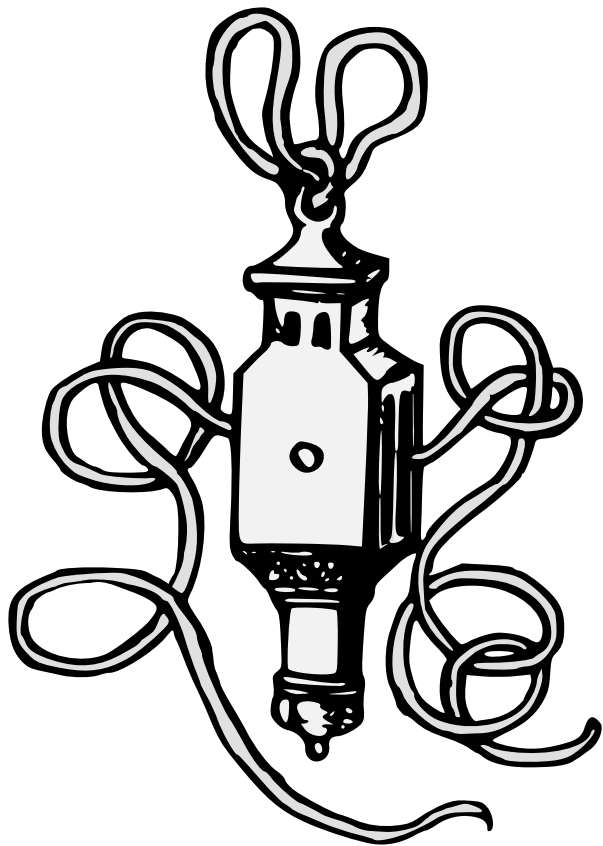

An assembly of pulleys used for lifting and hauling.

Source: Armorial de Flandre et du Hainaut.

Artist: Jacques Le Boucq. (View 169.)

Adapted by Iago ab Adam.

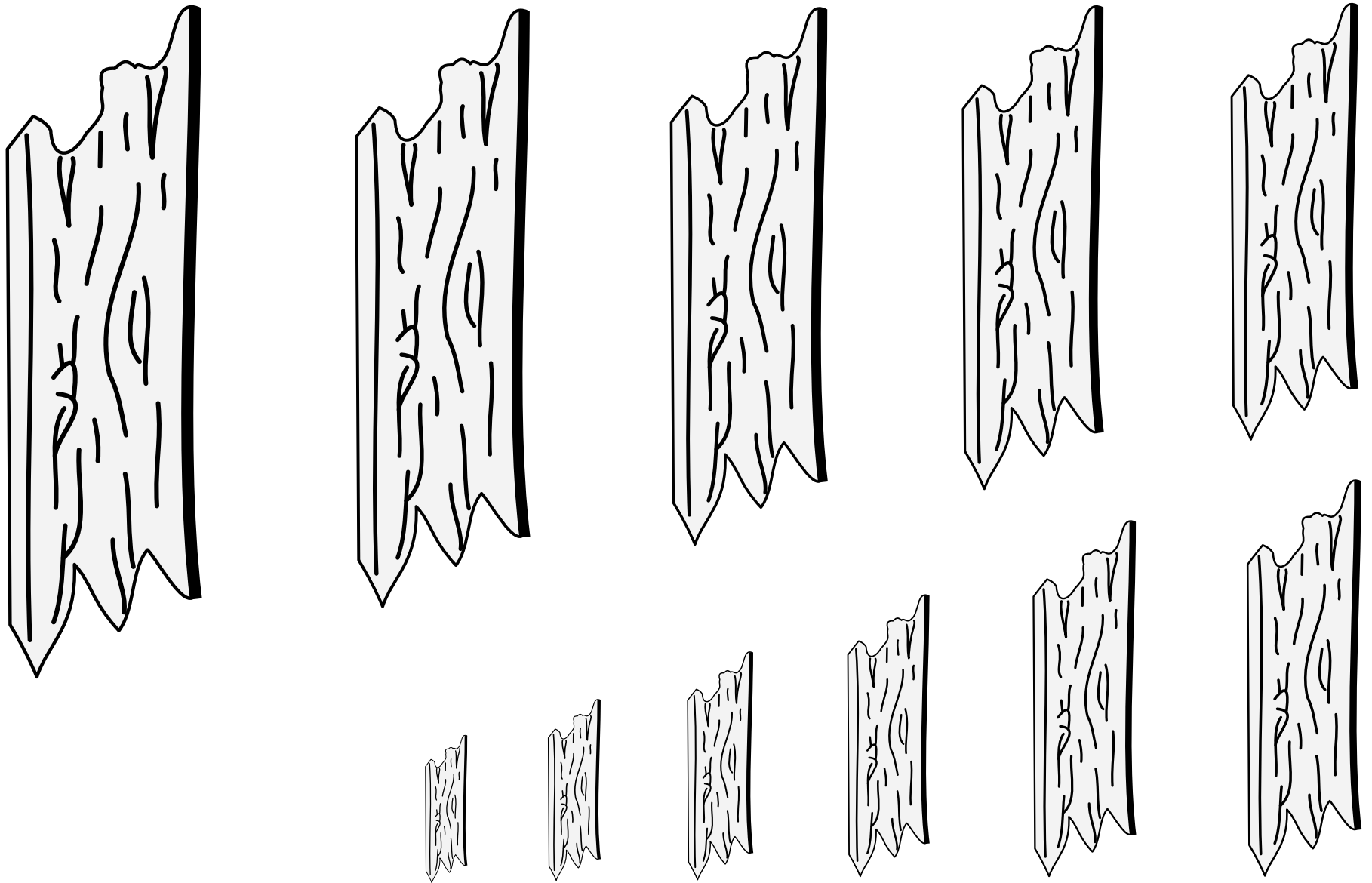

A piece of wood cut for use in construction.

No default orientation. Proper coloration: brown wood.

Source: Staats- und Universitätsbibliothek Dresden Wappenbuch 1642.
Artist unknown. Adapted by Iago ab Adam.

Board Palewise 16.42

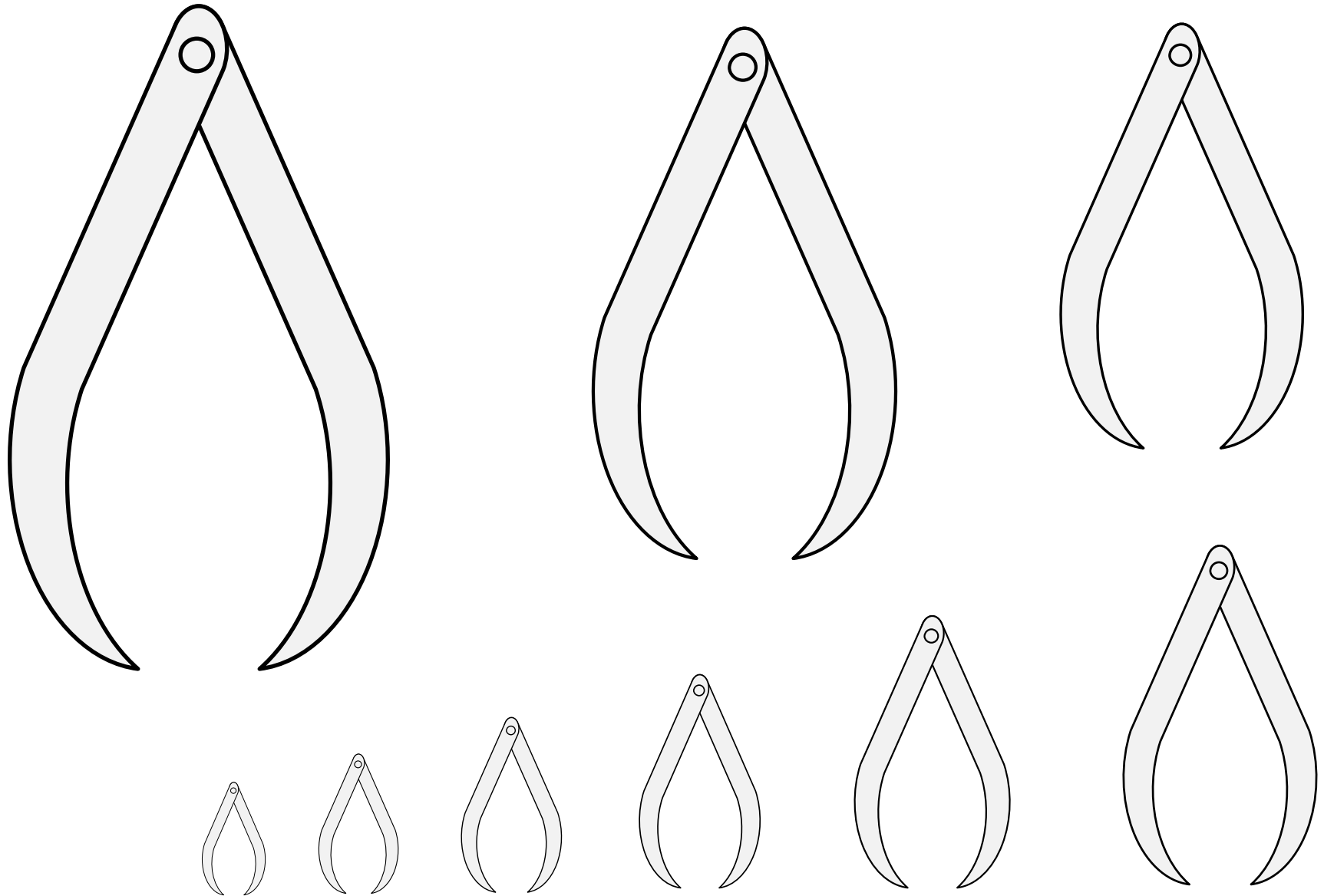

A measuring tool used for design and construction.

Default orientation: points to base, arms spread. No proper coloration.

Source: Viking Answer Lady SVG Images For Heraldry.

Artist: Gunnvôr silfrhárr.

Calipers, Pair Of (1) 16.43

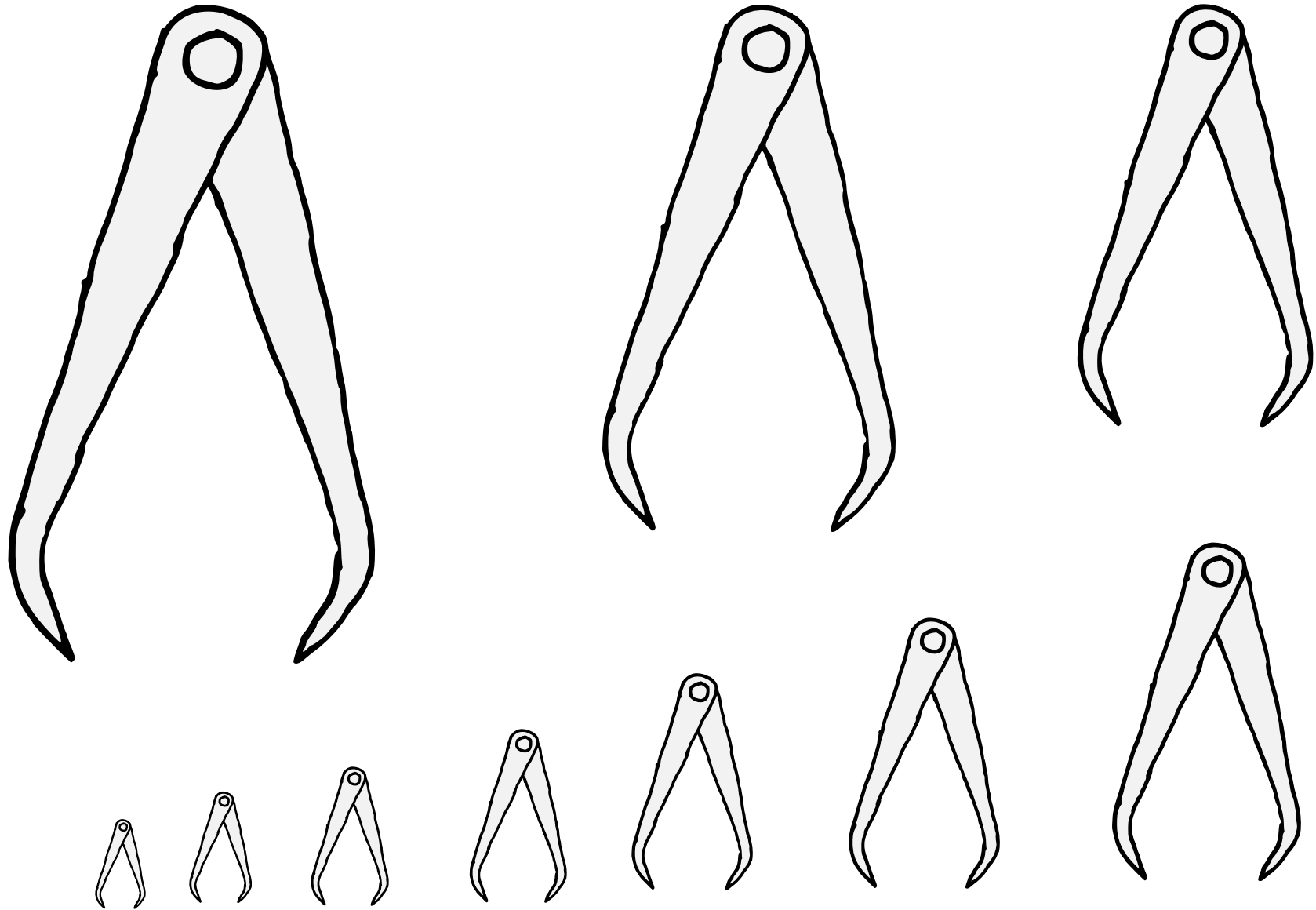

A measuring tool used for design and construction.

Default orientation: points to base, arms spread. No proper coloration.

Source: Pennsic Bored-Artist Collection. Artist: Jaqueline de Molières.

Calipers, Pair Of (2) 16.44

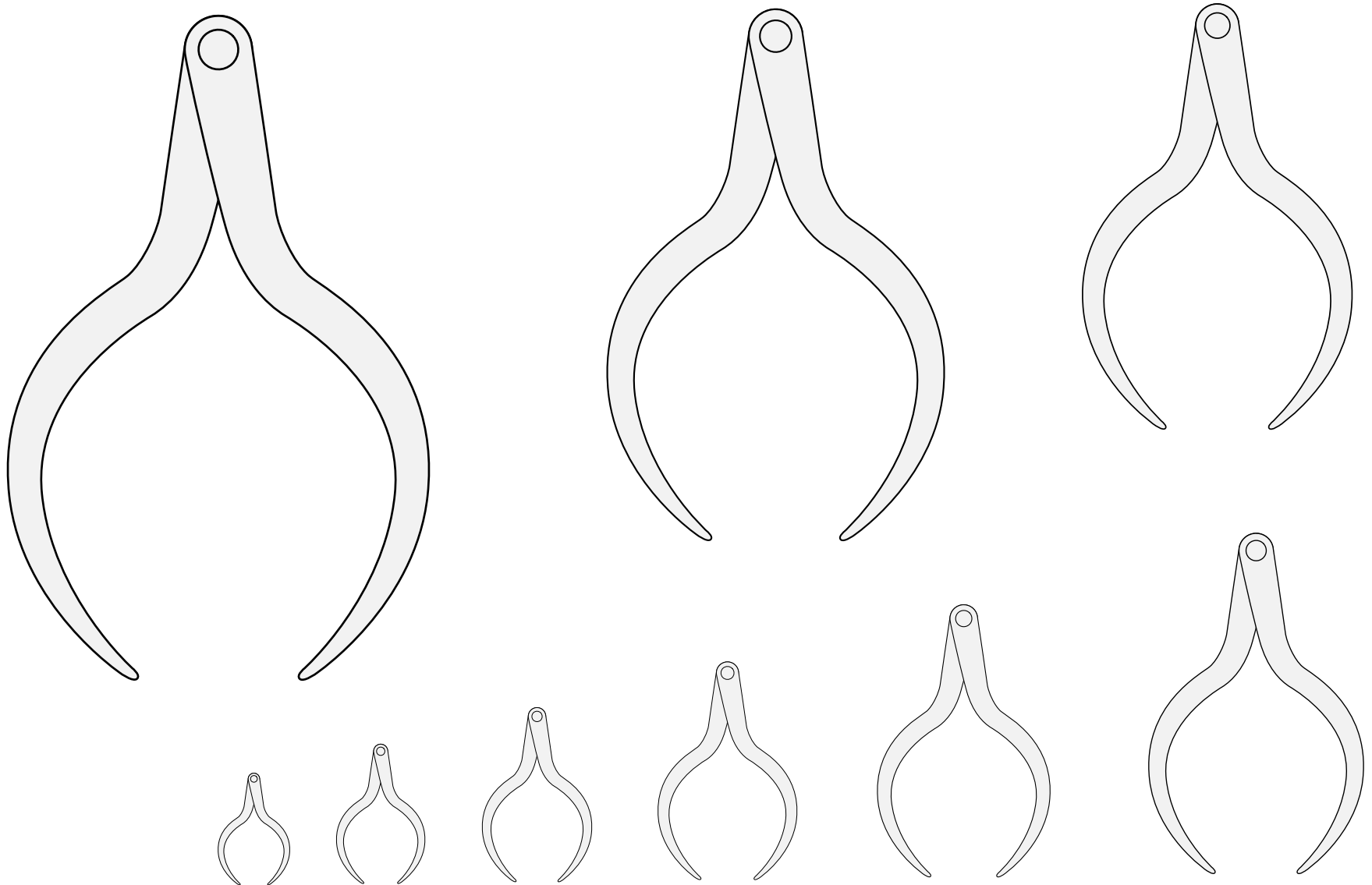

A measuring tool used for design and construction.
Default orientation: points to base, arms spread. No proper coloration.

Calipers, Pair Of (3) 16.45

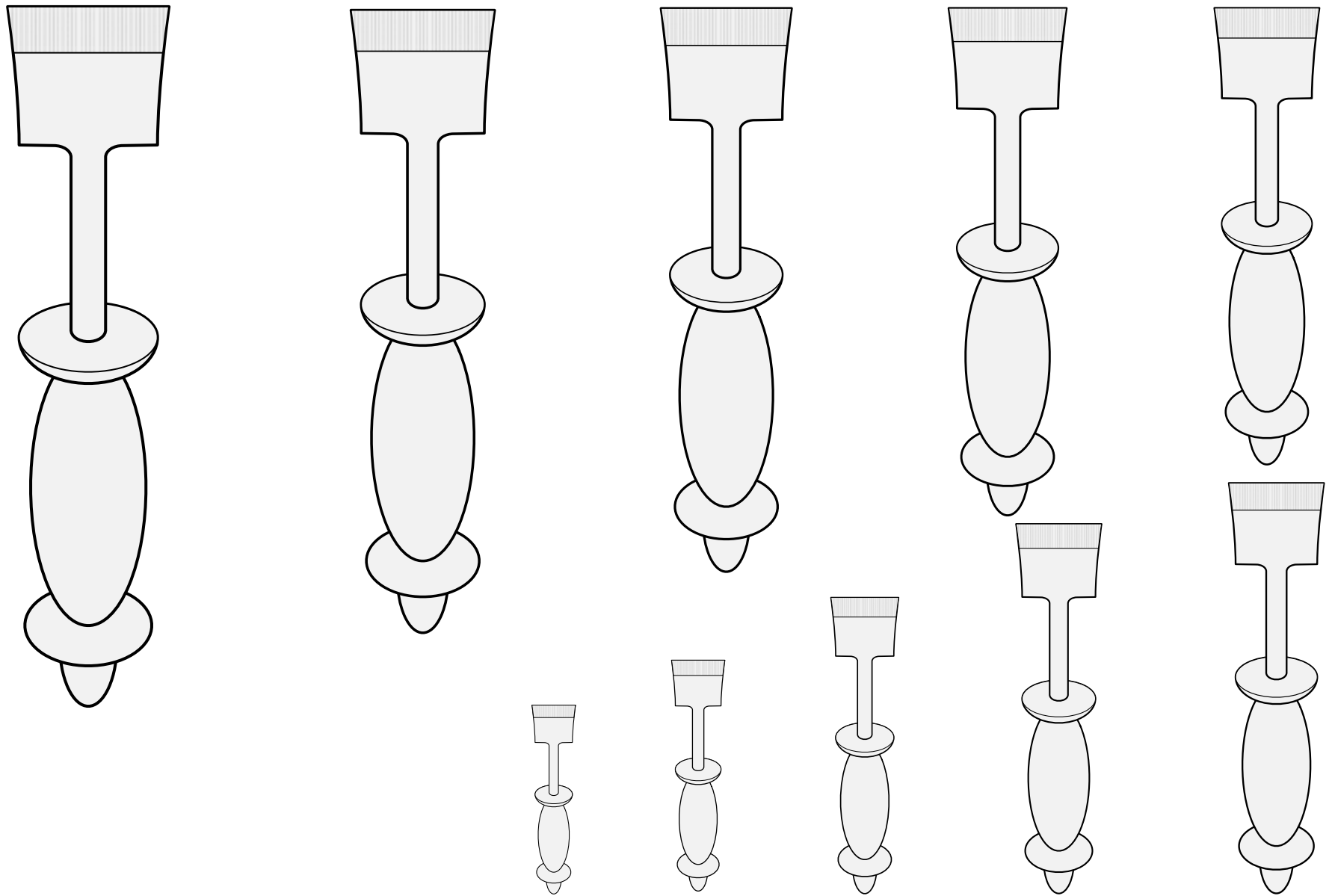

A sharp wood-working tool.

Default orientation: palewise, handle to base. No proper coloration.

Source: Fenwick Roll. Artist unknown. (Arms of Chiselden.)

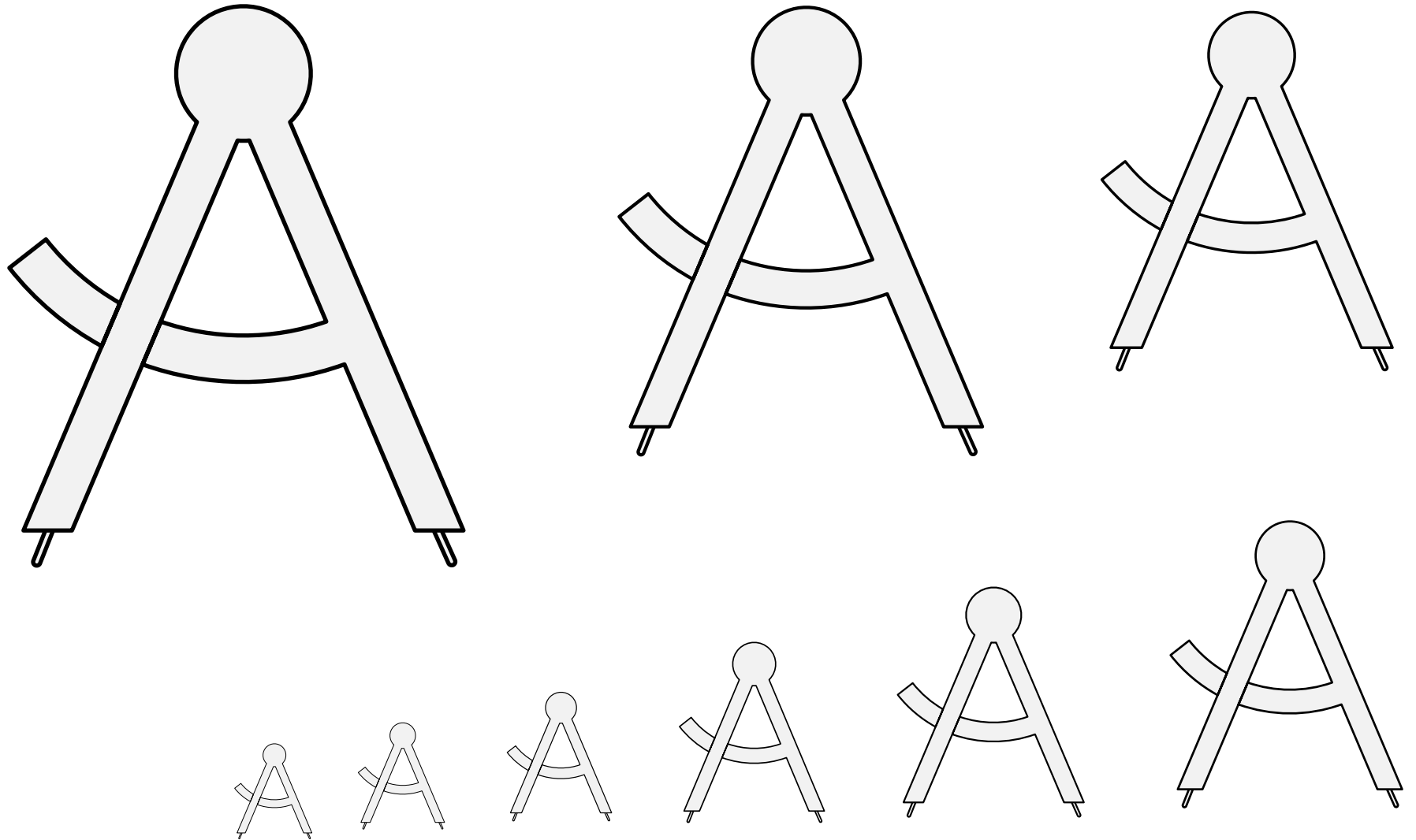

Two pins joined by a pivot used for measurement when drawing or building.

Default orientation: points to base, arms spread. No proper coloration.

Source: Siebmacher's Wappenbuch of 1605. Artist: Johann Siebmacher.
(Arms of Petzlinger, page 98.)

Compass, Drawing (1) 16.47

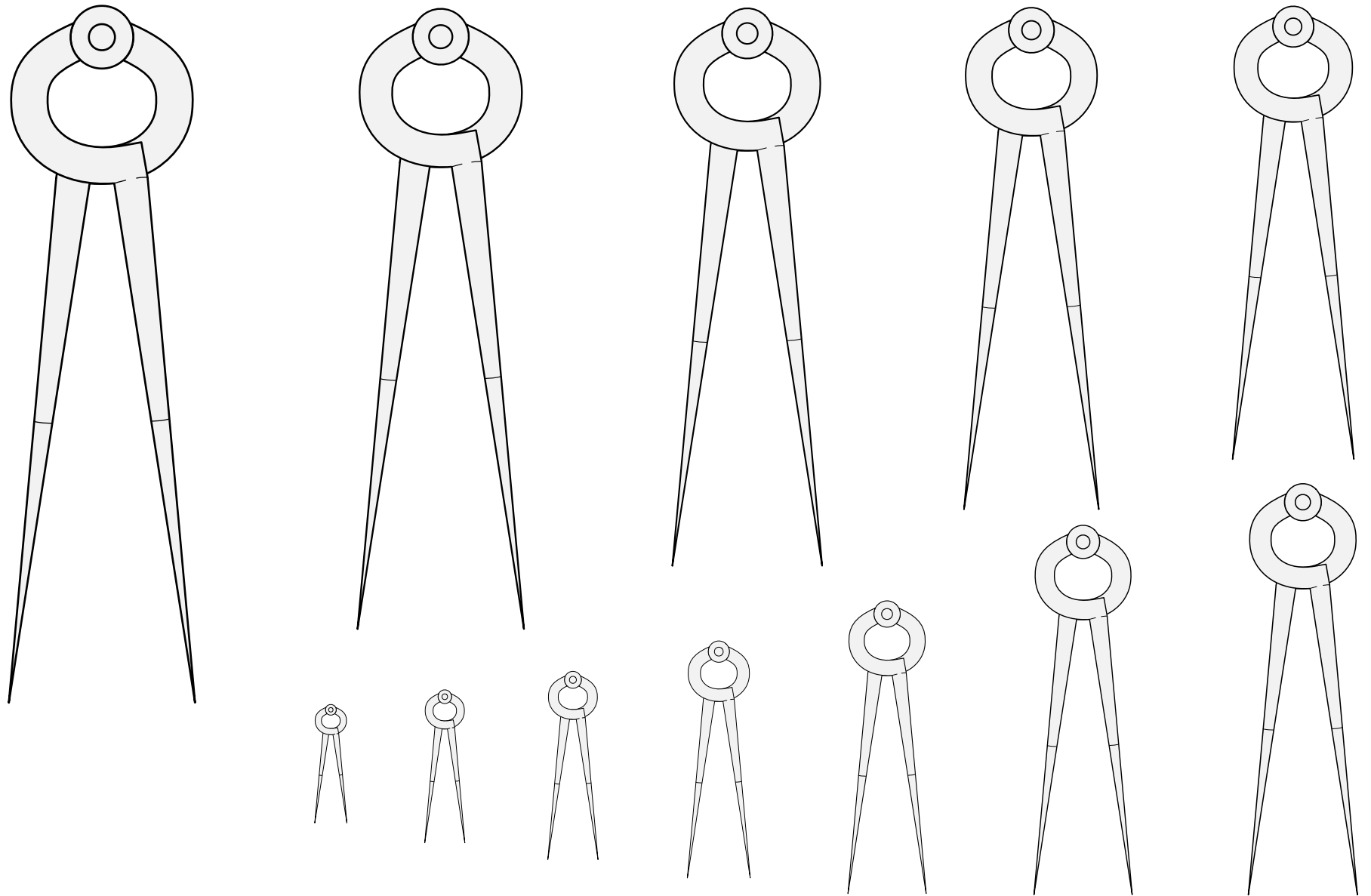

Two pins joined by a pivot used for measurement when drawing or building.

Default orientation: points to base, arms spread. No proper coloration.

Adapted from a photograph of Boijmans van Beuningen's
Compass no. F 6454, dated to the 15th C.

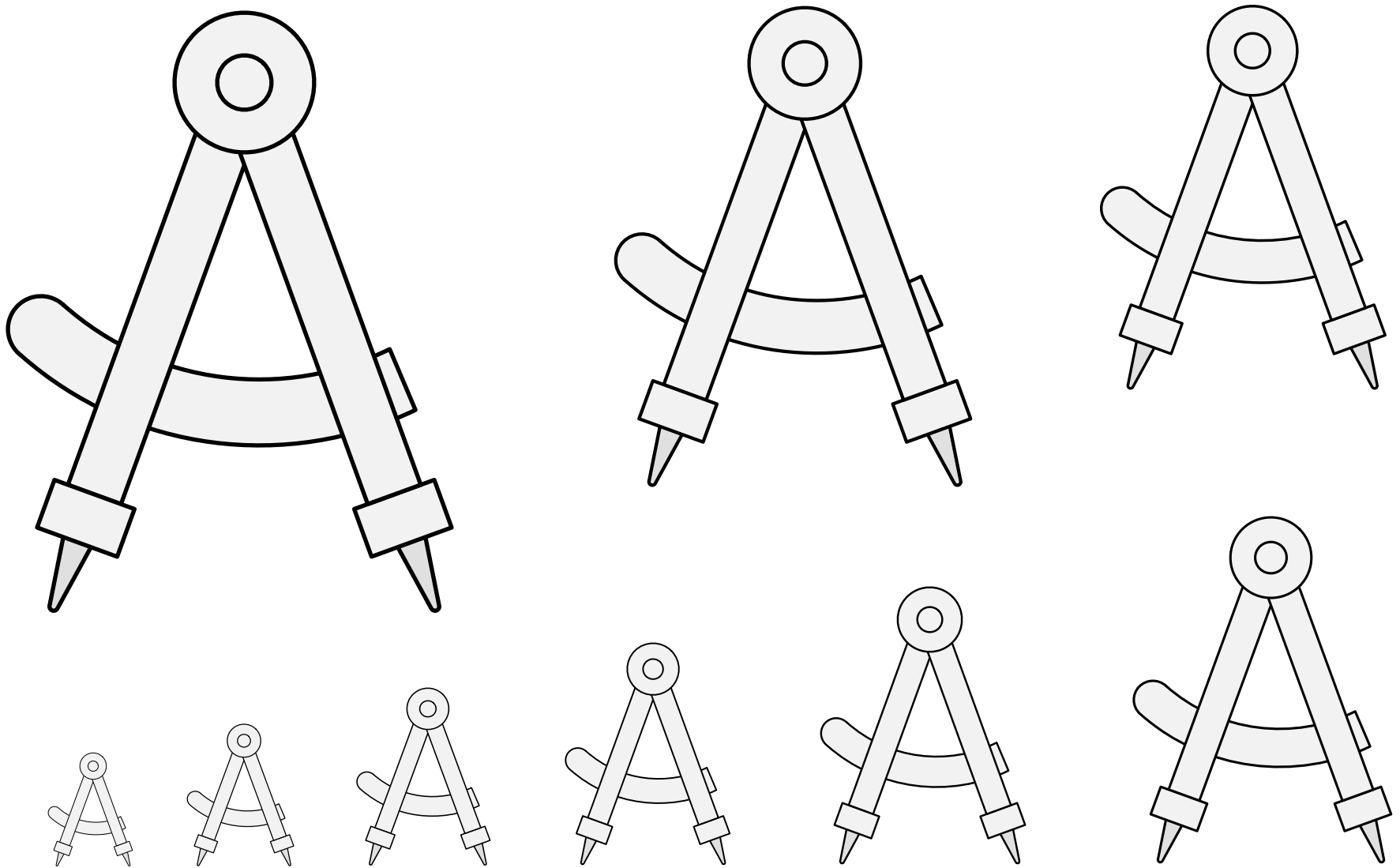

Two pins joined by a pivot used for measurement when drawing or building.

Default orientation: points to base, arms spread. No proper coloration.

Source: Wappenbuch Fol 223. (Folio 35v.) Artist unknown.

Adapted by Mathghamhain Ua Ruadháin.

Compass, Drawing (3) 16.49

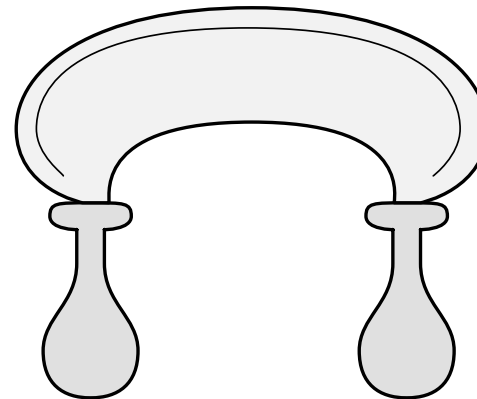
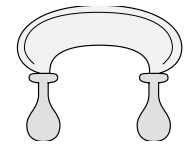
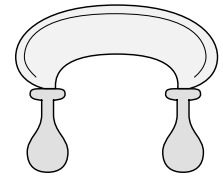
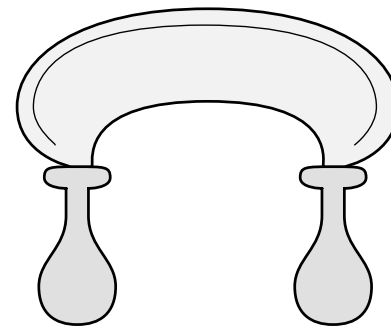
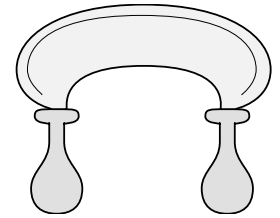
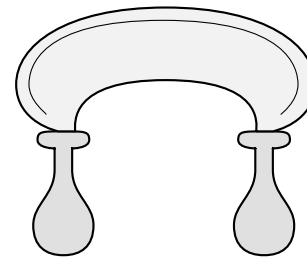
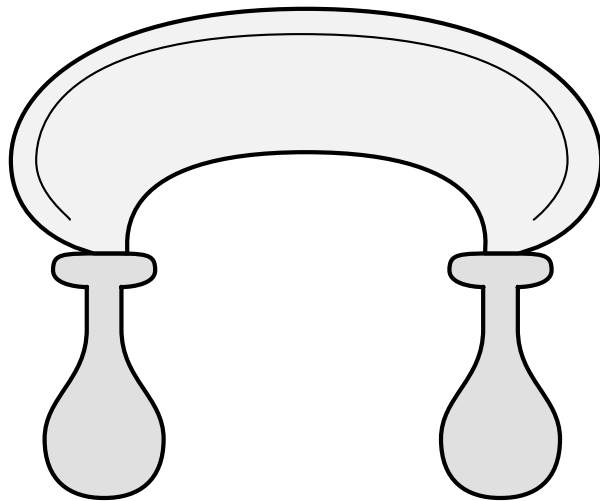
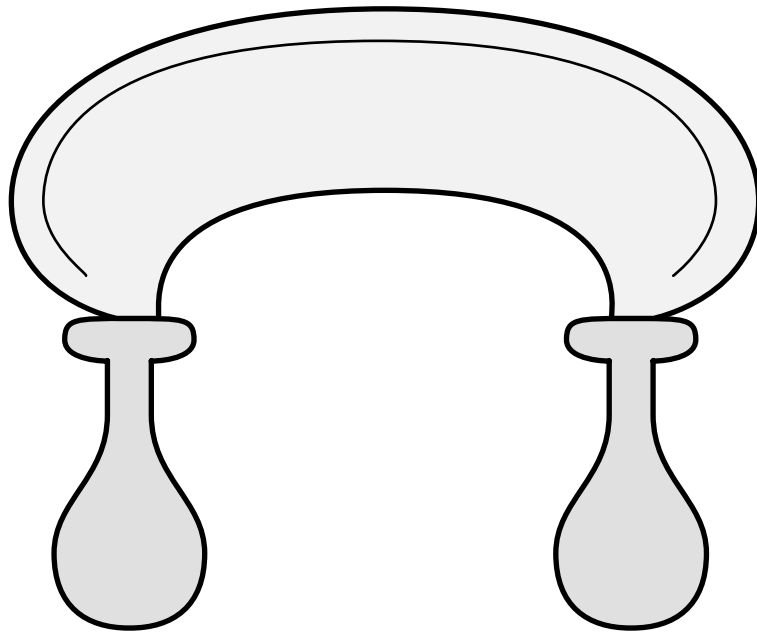

A woodworking tool used to shave lumber smooth.

Default posture: handles to base. No proper coloration.

Source: Siebmacher's Wappenbuch of 1605. Artist: Johann Siebmacher.
(Arms of Scharben, page 139.)

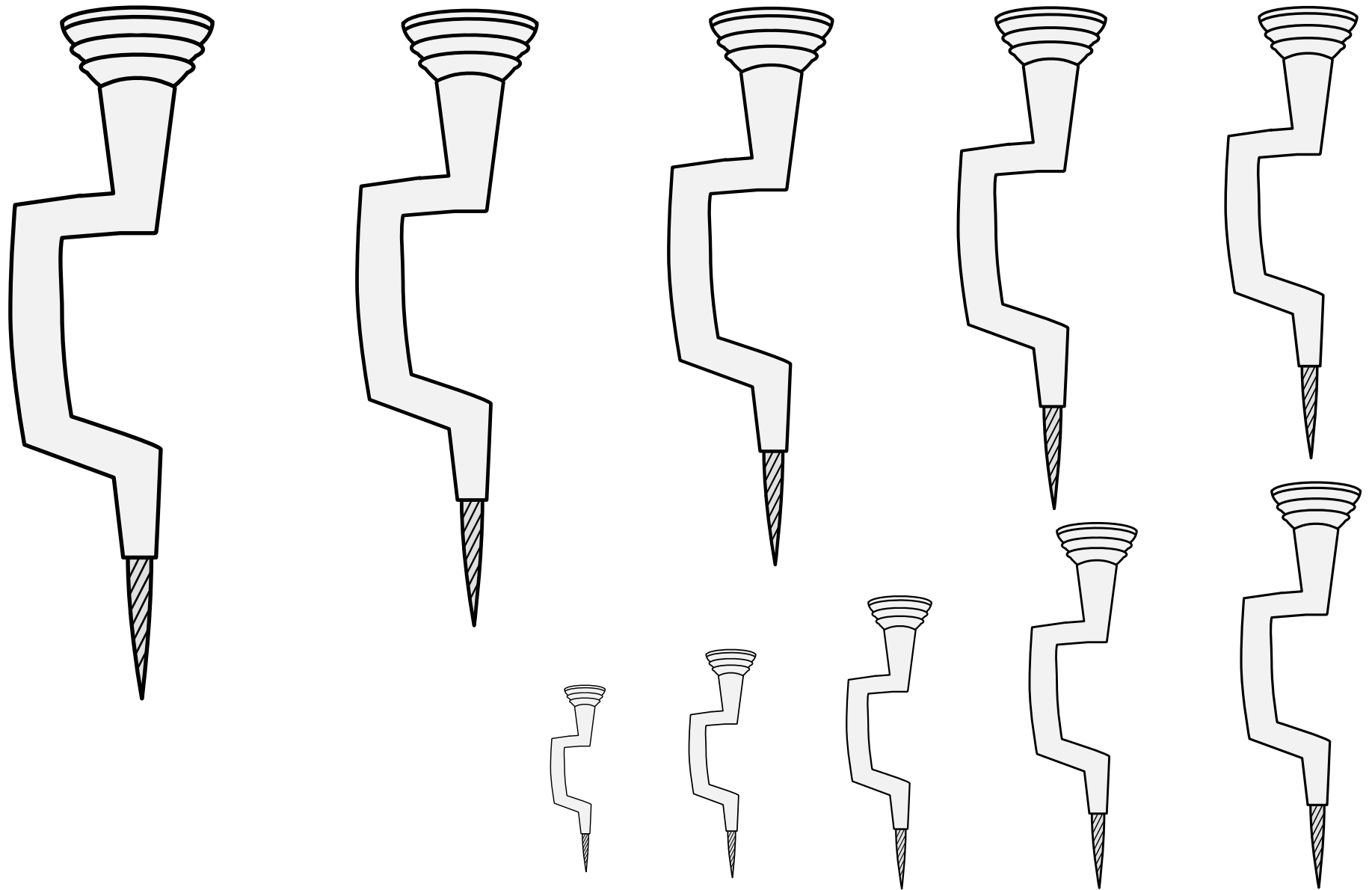

A woodworking tool used for making holes, with an offset hand crank for rotary power.

Default orientation: upright. No proper coloration.

Source: Flandria Roll. Artist unknown. (Folio 71v.)

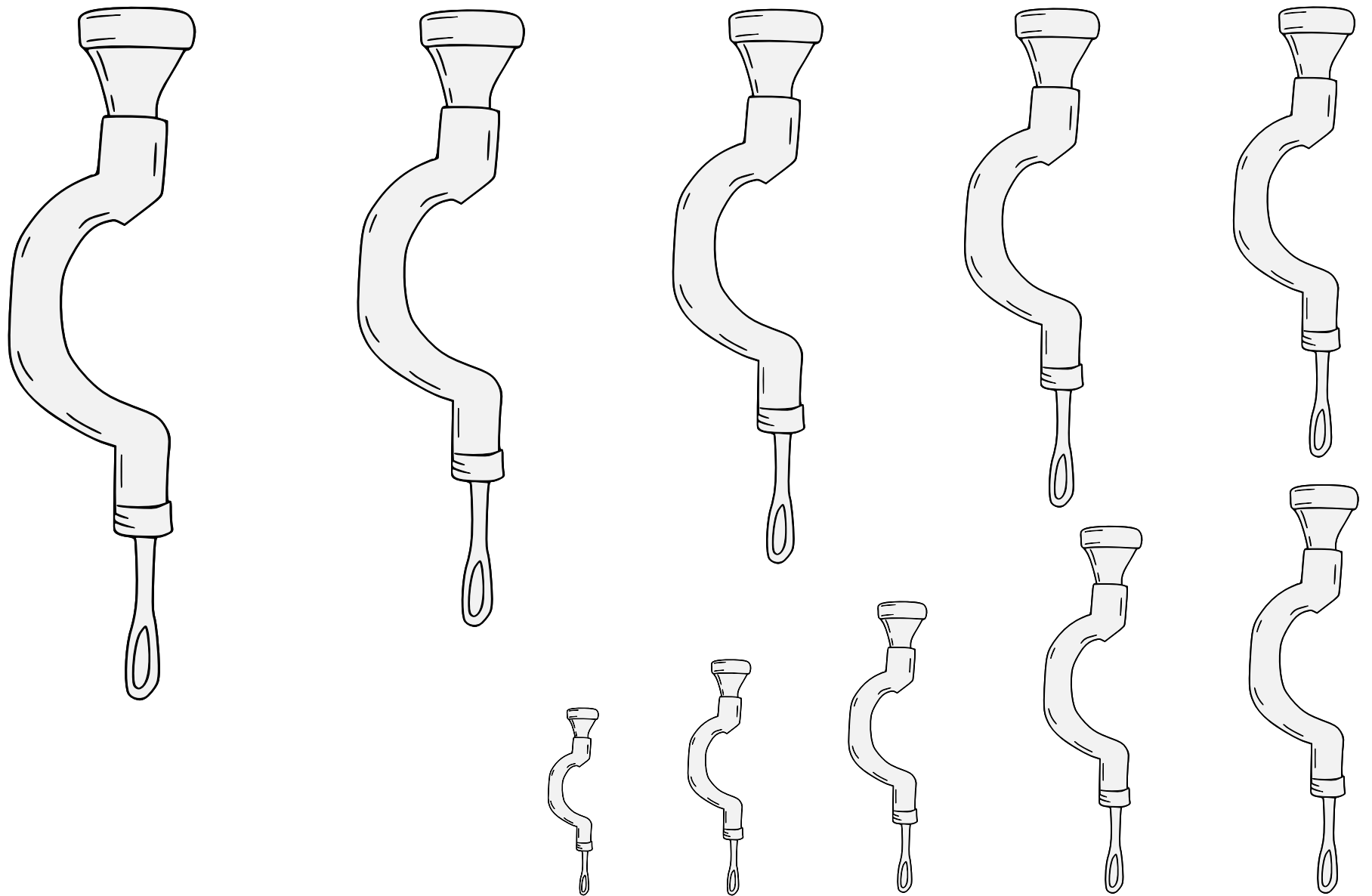

A woodworking tool used for making holes, with an offset hand crank for rotary power.

Default orientation: upright. No proper coloration.

Source: The Tudor Pattern Book. Artist unknown. Adapted by Owen Tegg.

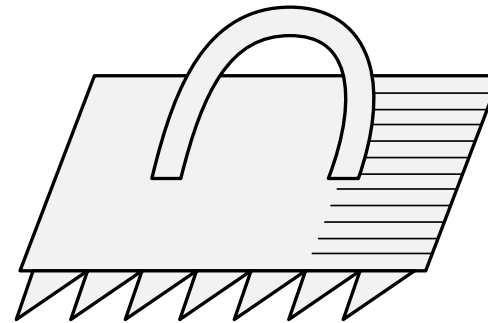
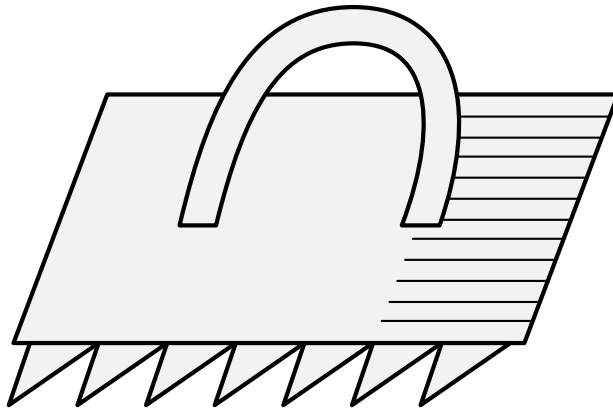
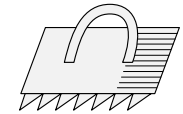
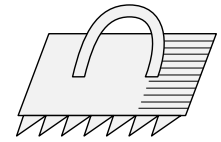
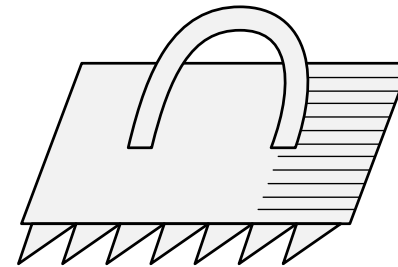
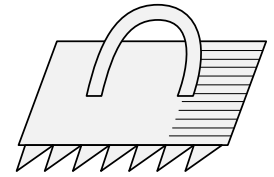
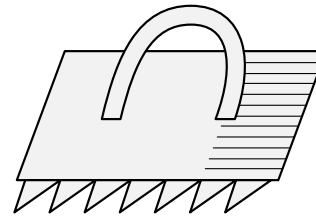
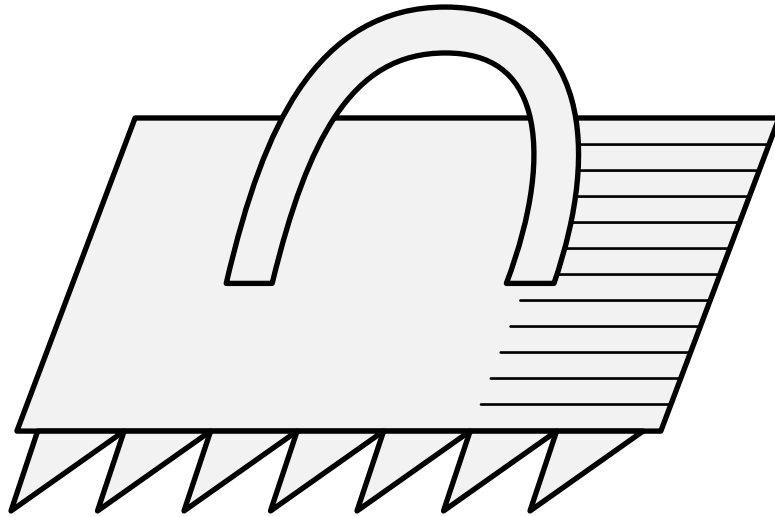

A tool used to shave the wood used to make a bow.

Default orientation: handle to chief. No proper coloration.

Source: The Armes of All the Cheife Corporatons.

Adapted by Mathghamhain Ua Ruadháin.

(From the arms of the Bowyers' Company.)

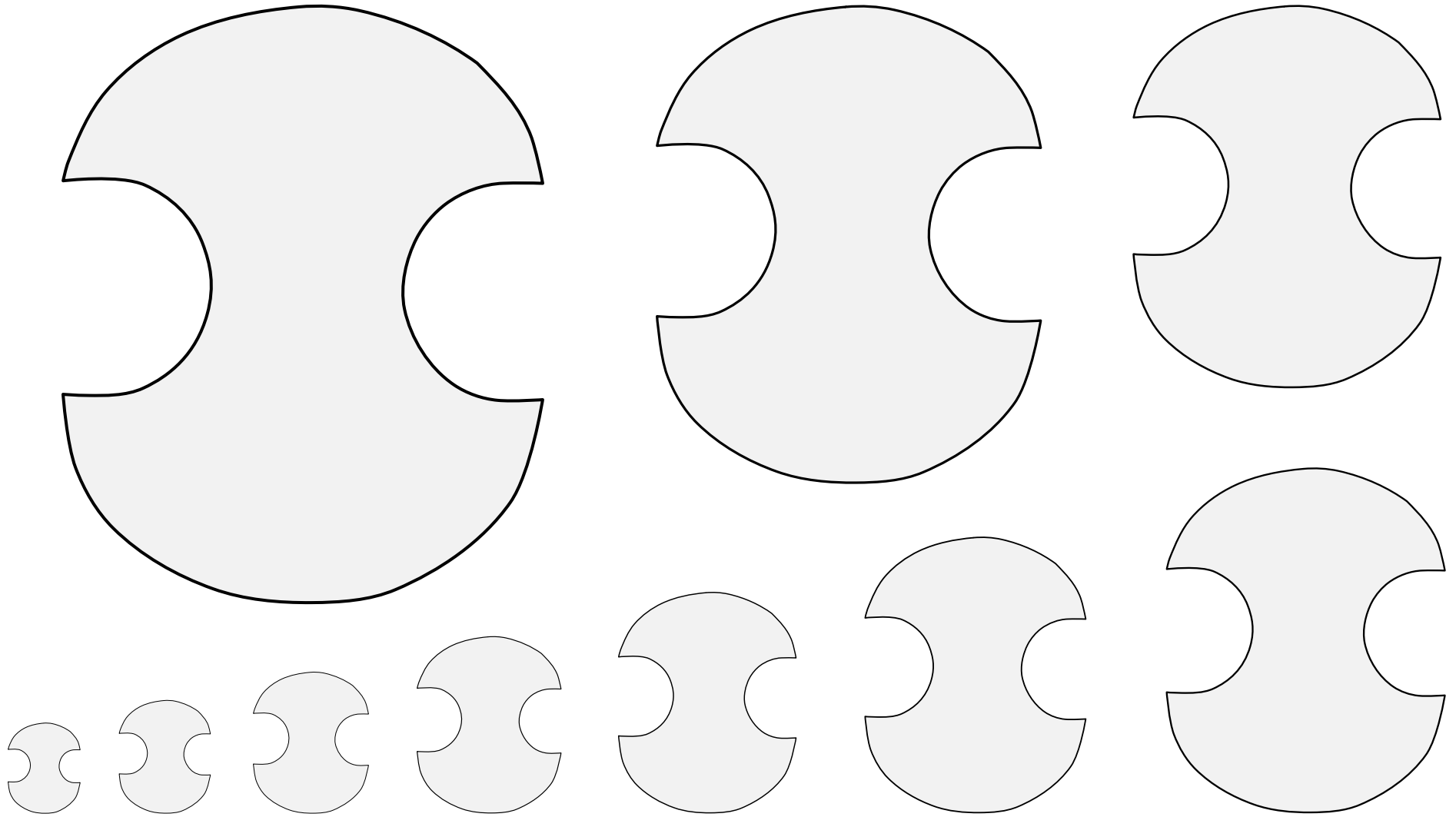

A small lump of metal of a known mass, used when balancing scales to weigh something.

Found in Japanese armory where it is said to represent the weights used by money changers. Similar weights were also used to measure silk and other material.

Default orientation: notches in fess. No proper coloration.

Source: O-umajirushi. Artist: Kyūan. (Mon of Horio Tadaharu.)
Adapted by Séamus Uí Chonchobhair.

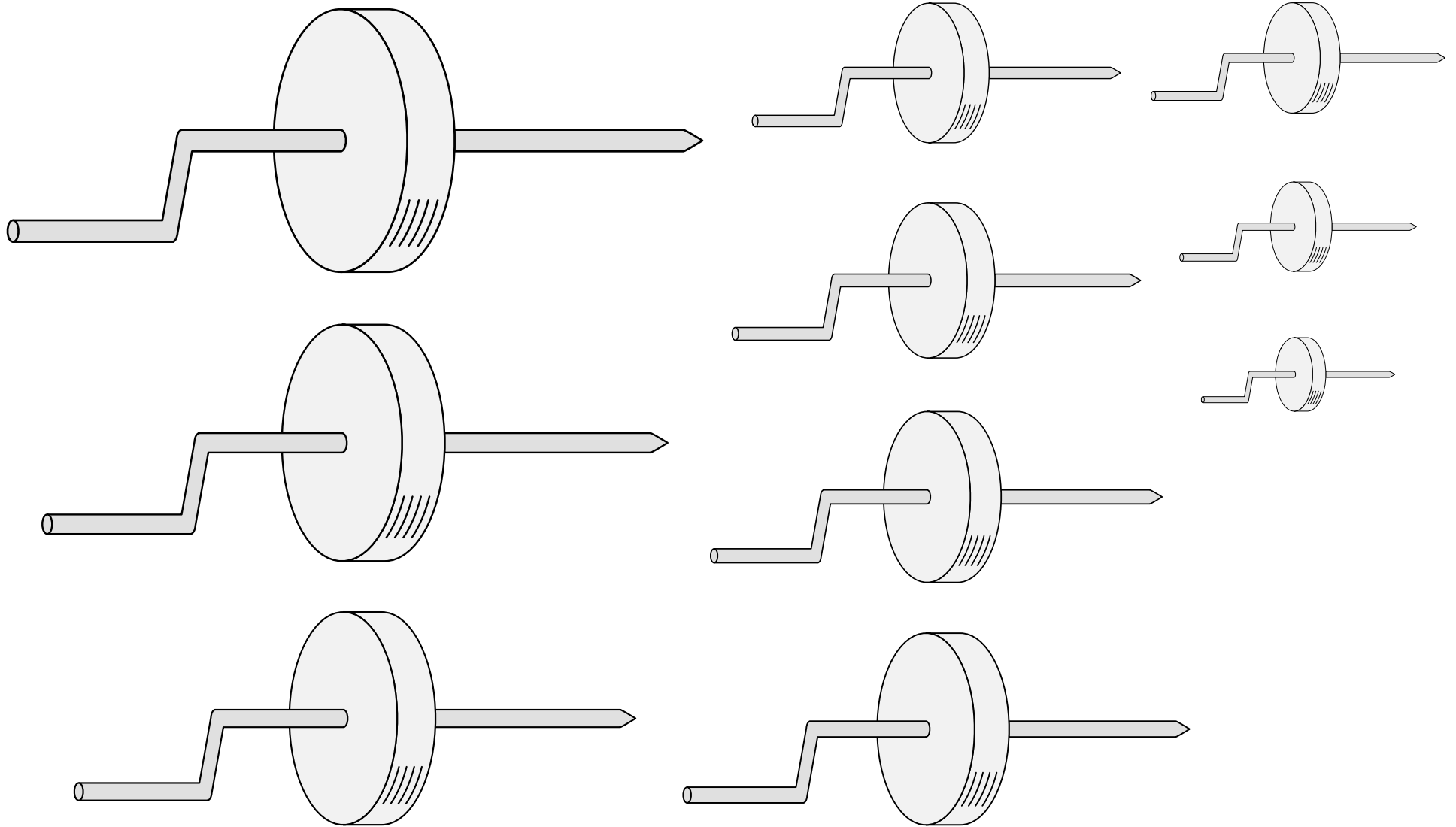

A rotary tool for sharpening tools.

No default orientation. No proper coloration.

Source: Stemmario Trivulziano. Artist: Gian Antonio da Tradate.
(Arms of da Moli, p 226.)

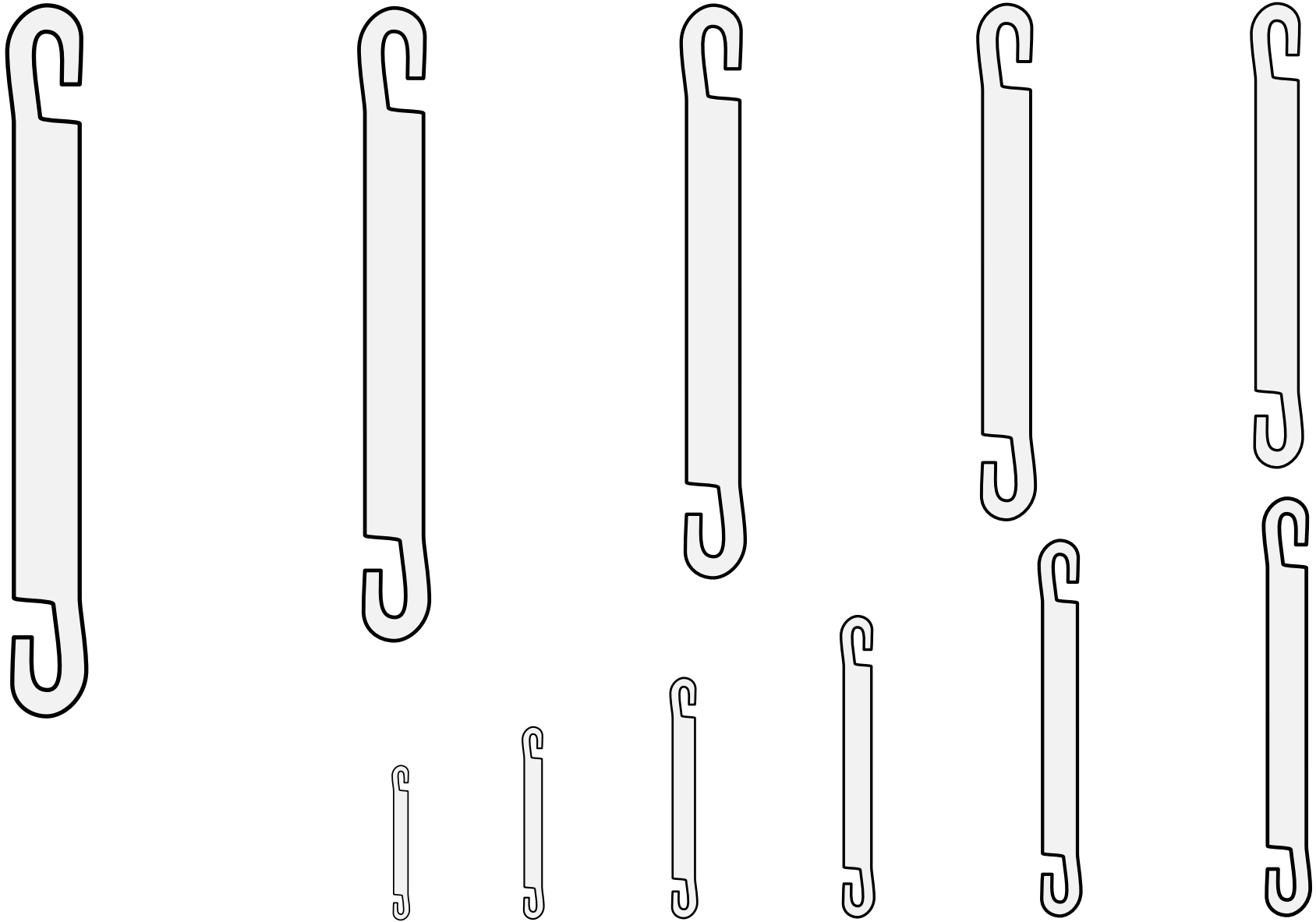

A tool for trimming the edges of pieces of glass.
No default orientation. No proper coloration
Adapted from images of medieval artifacts.

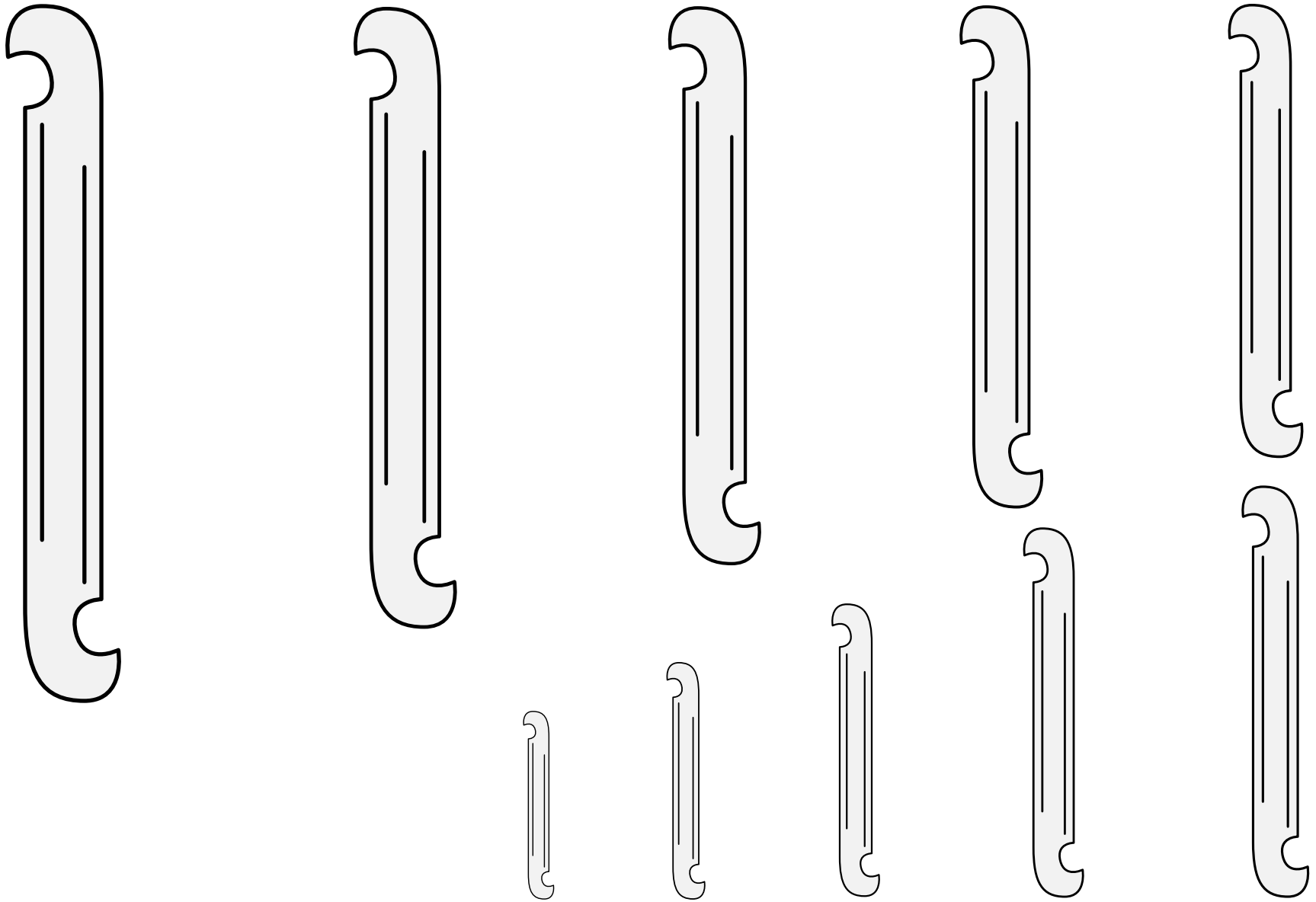

A tool for trimming the edges of pieces of glass.

No default orientation. No proper coloration

Source: Wappenbuch der Arlberg-Bruderschaft. Artist: Vigil Raber. (Folio 69r.)

Grozing Iron (2) 16.57

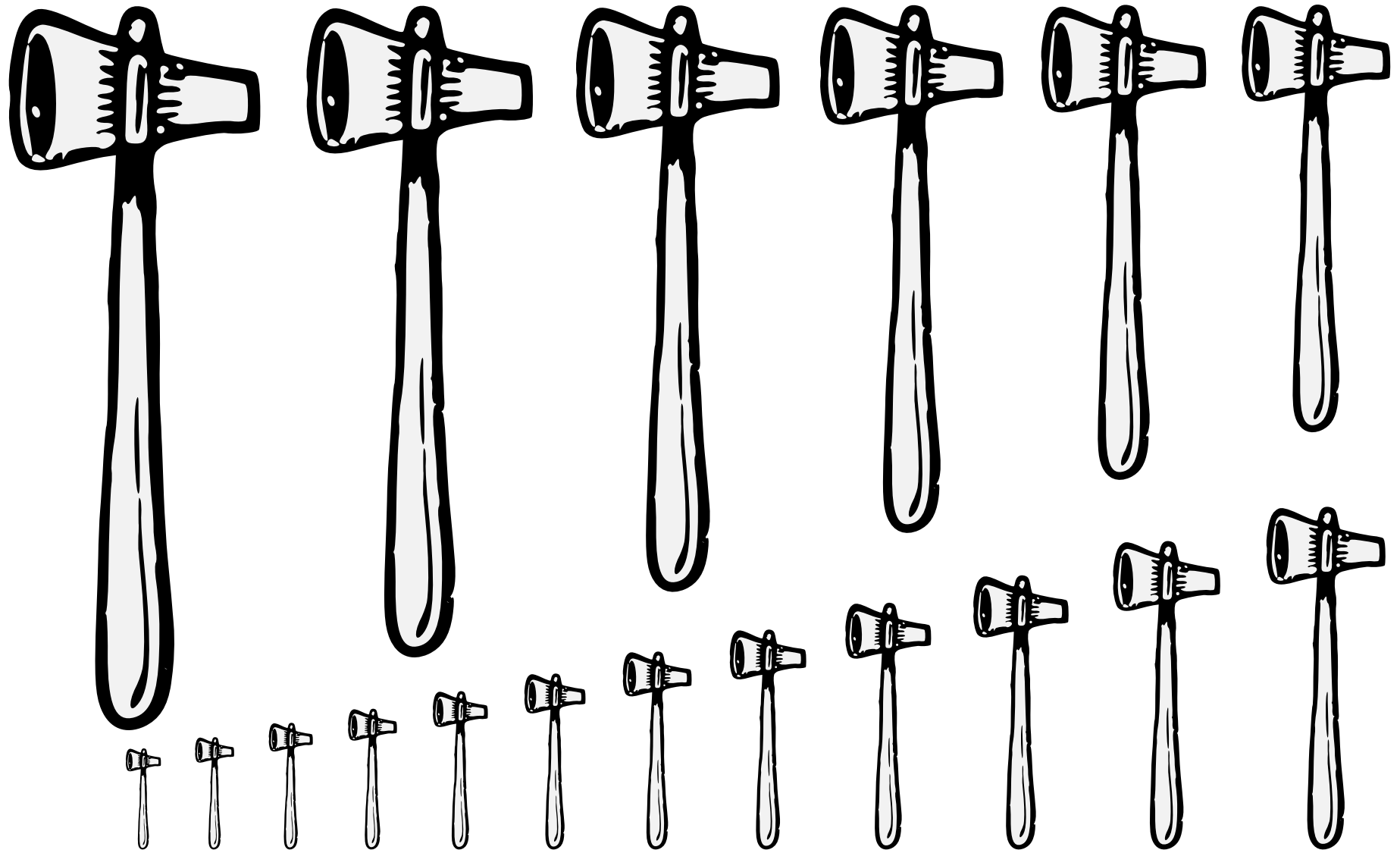

A pounding tool.

Default orientation: head to chief, striking to dexter. Proper coloration: sable head and brown wood handle.

A submission using this depiction was pended for redraw in January 2021 due to difficulty identifying it as a hammer rather than a tomahawk.

Source: A Complete Guide to Heraldry. Artist: Graham Johnston.

Hammer (1) 16.58

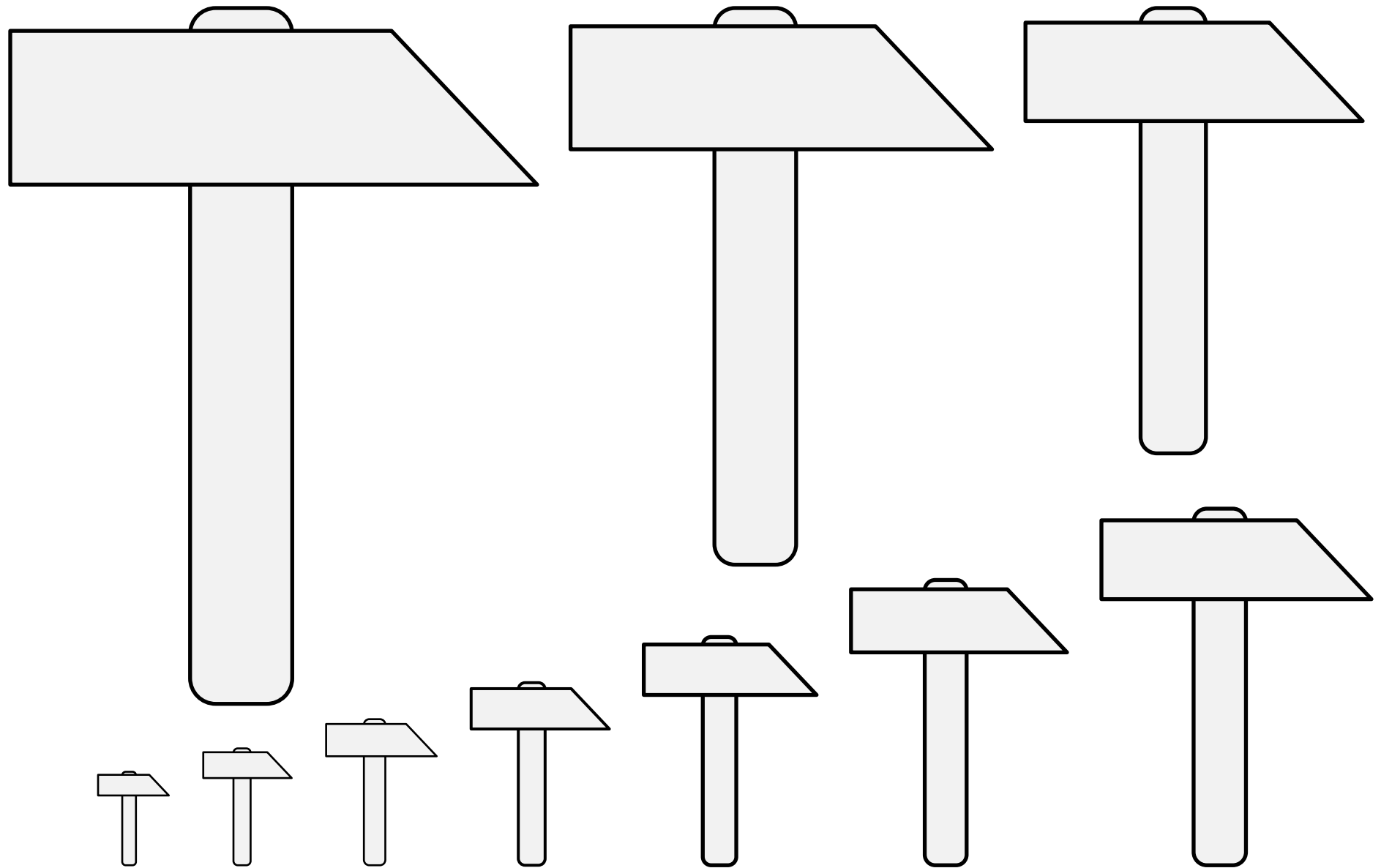

A pounding tool.

Default orientation: head to chief, striking to dexter. Proper coloration: sable head and brown wood handle.

Source: Viking Answer Lady SVG Images For Heraldry. Artist: Gunnvôr silfráhr.

Hammer (2) 16.59

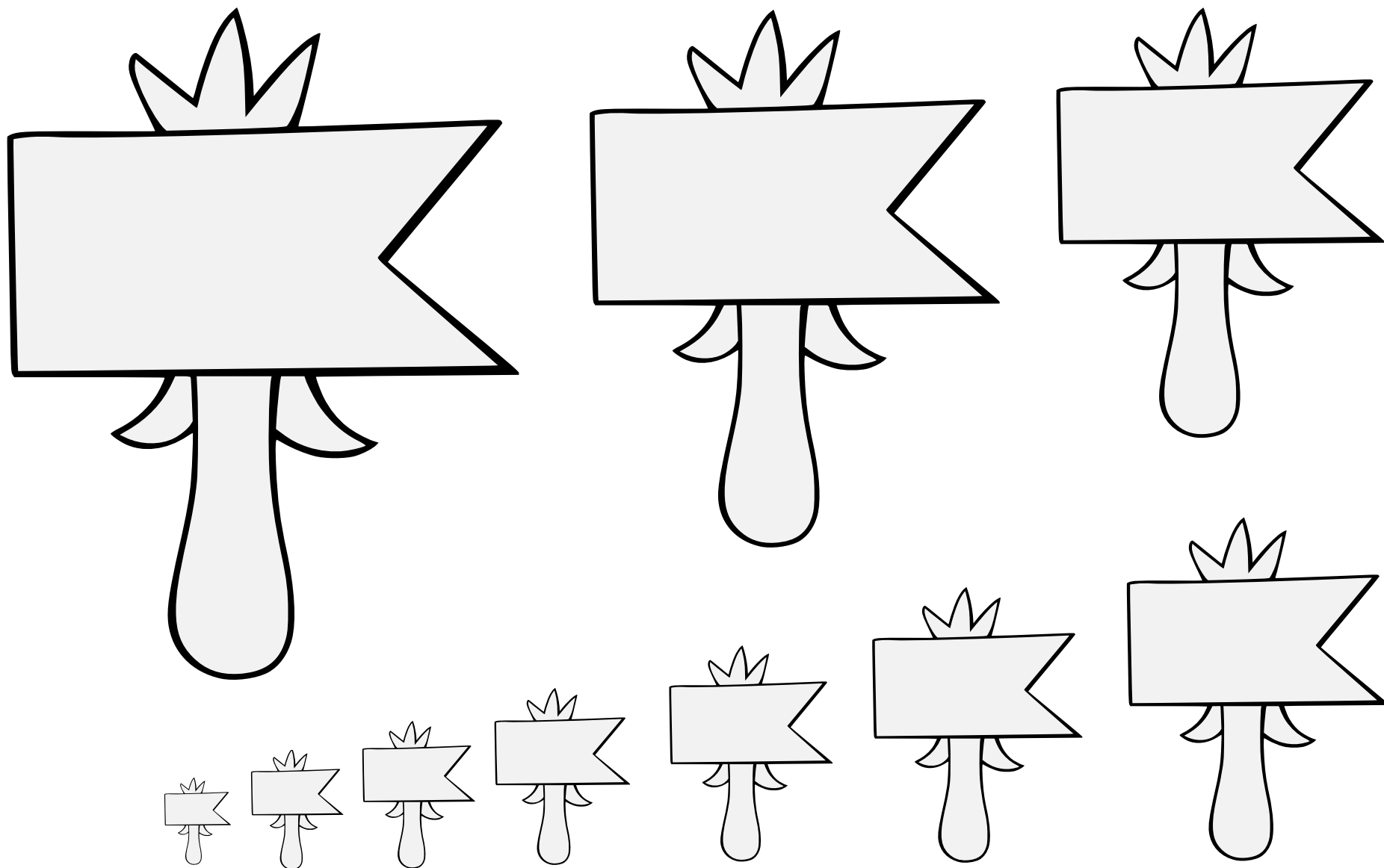

A pounding tool.

Default orientation: head to chief, striking to dexter.

Proper coloration: sable head and brown wood handle.

Source: Pennsic Traceable Art Archives. Artist: Ian Raven of Tadcaster.

Hammer (3) 16.60

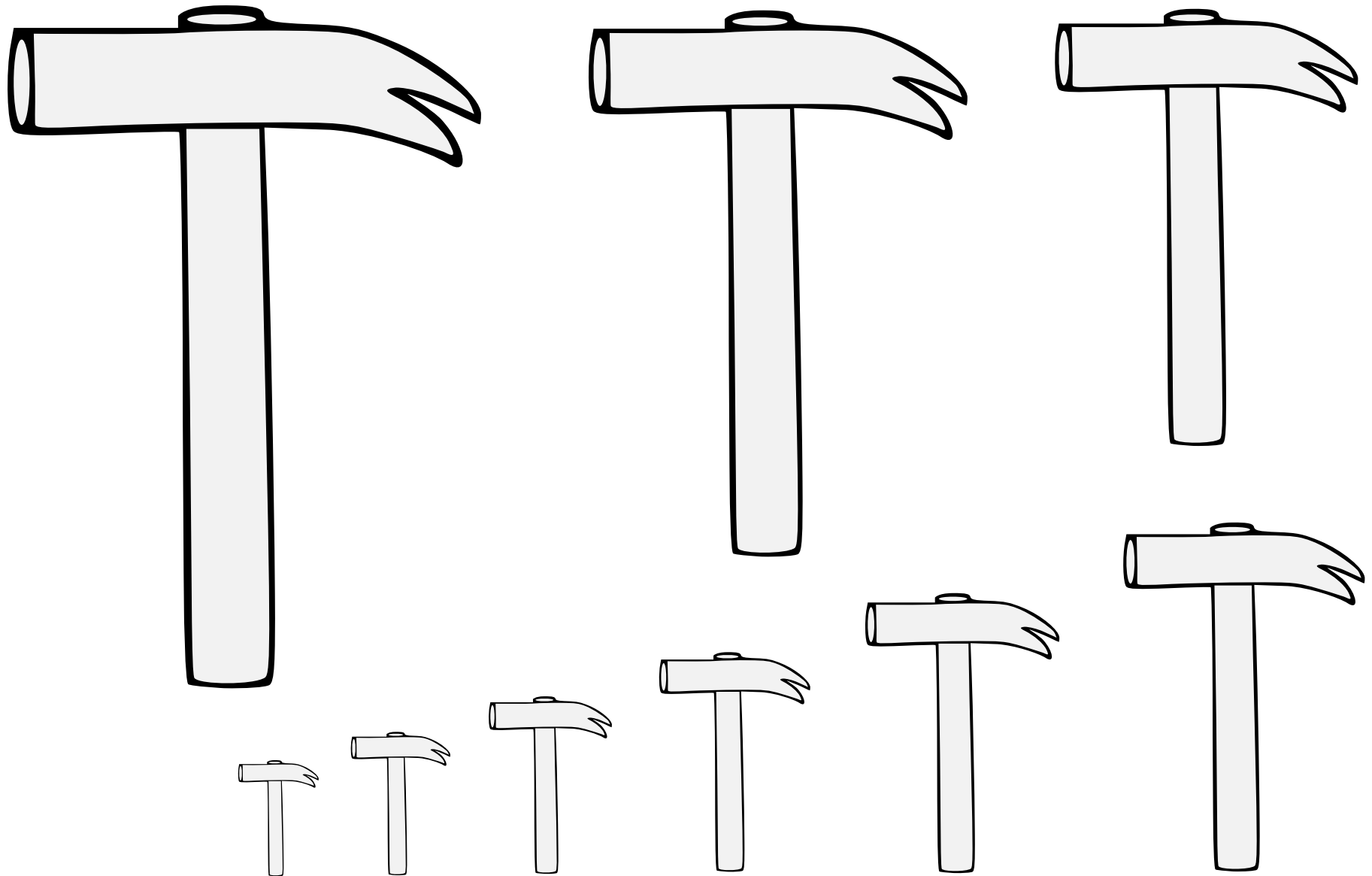

A pounding tool.

Default orientation: head to chief, striking to dexter.
Proper coloration: sable head and brown wood handle.

Source: Pennsic Traceable Art. Artist: Unknown.

Hammer (4) 16.61

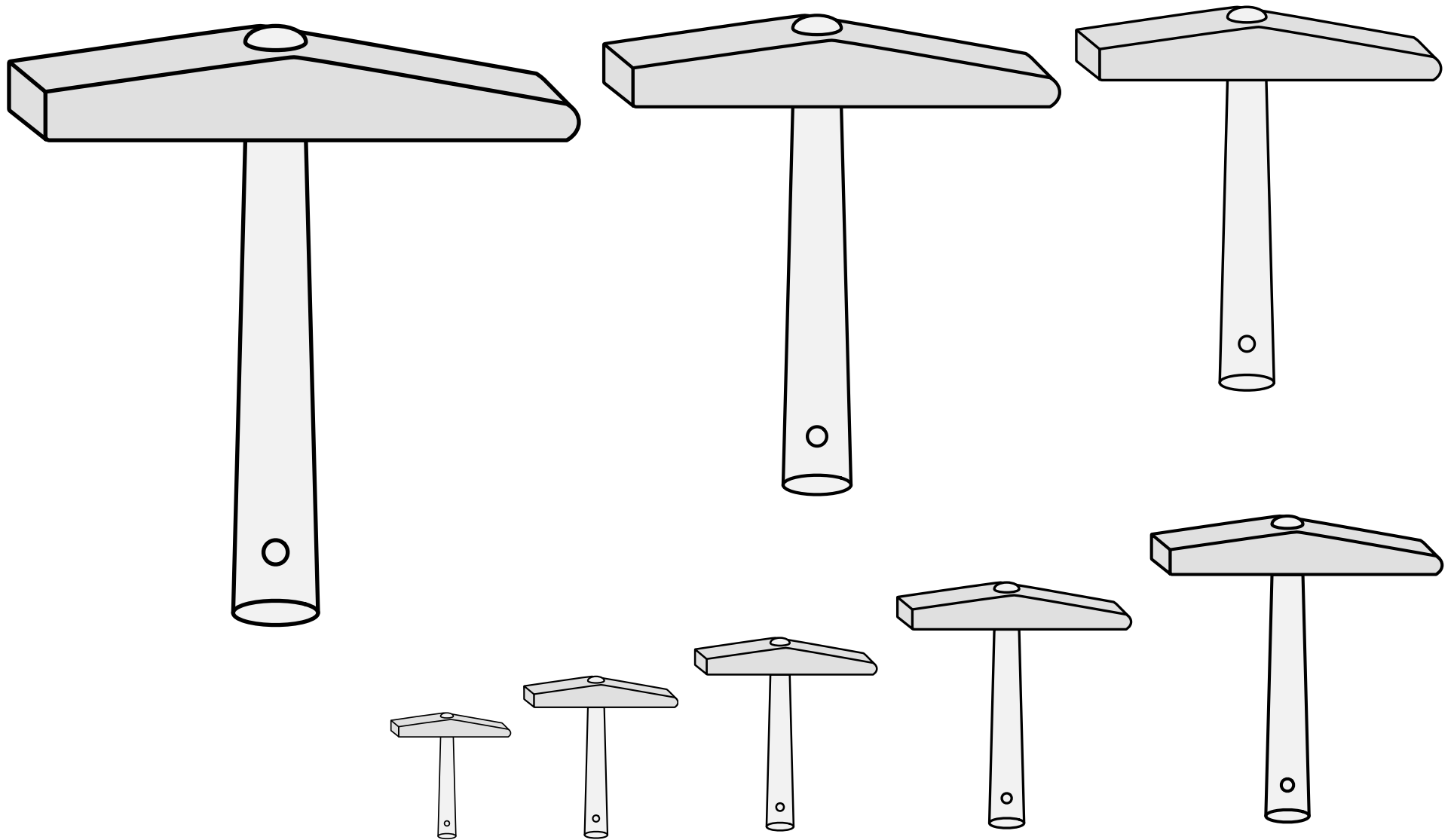

A pounding tool.

Default orientation: head to chief, striking to dexter.

Proper coloration: sable head and brown wood handle.

Source: Wappenbuch der Arlberg-Bruderschaft. Artist: Vigil Raber.

Hammer (5) 16.62

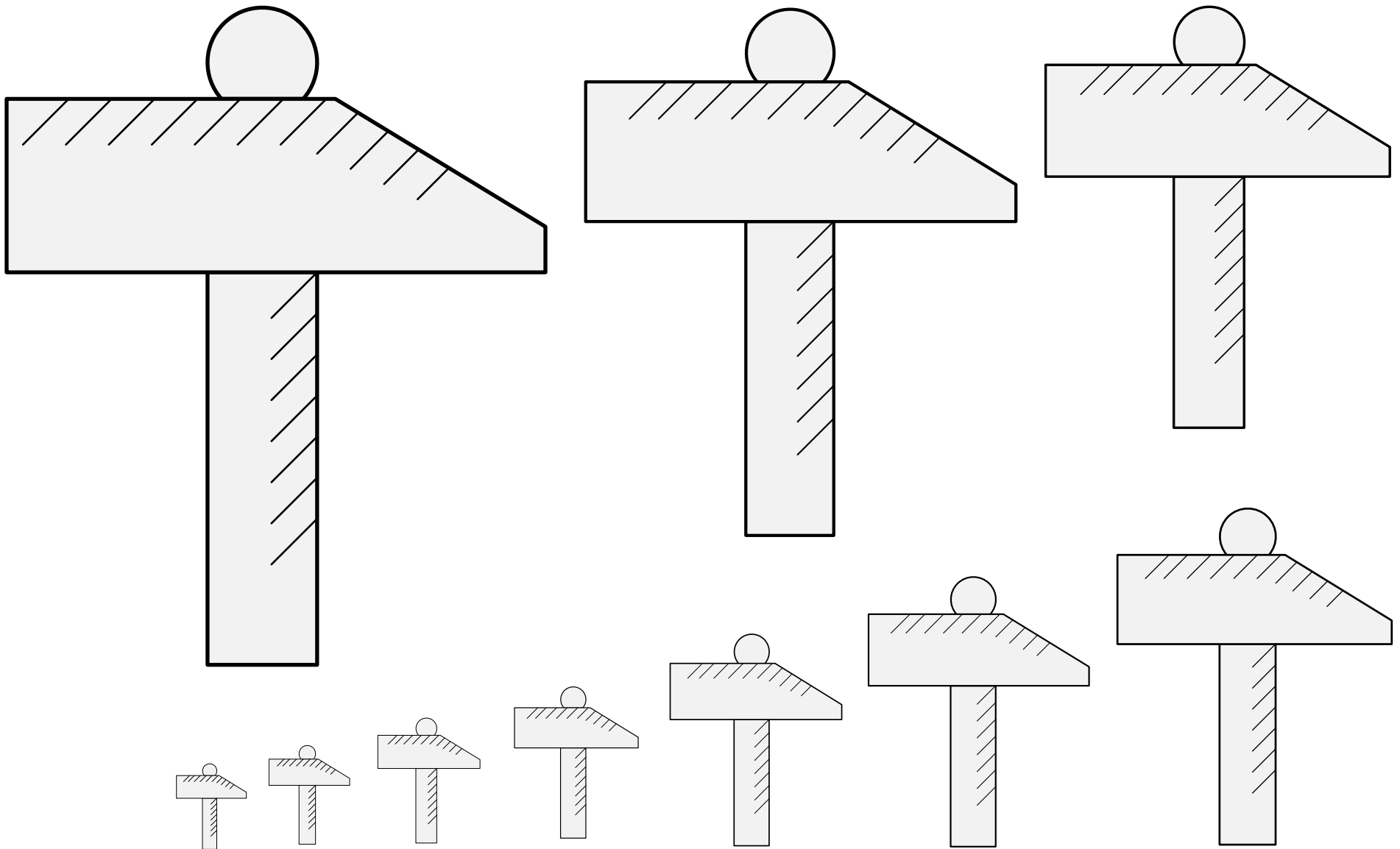

A pounding tool.

Default orientation: head to chief, striking to dexter.
Proper coloration: sable head and brown wood handle.

Source: Lewis Armorial. Artist unknown. (Folio 12r.)

Hammer (6) 16.63

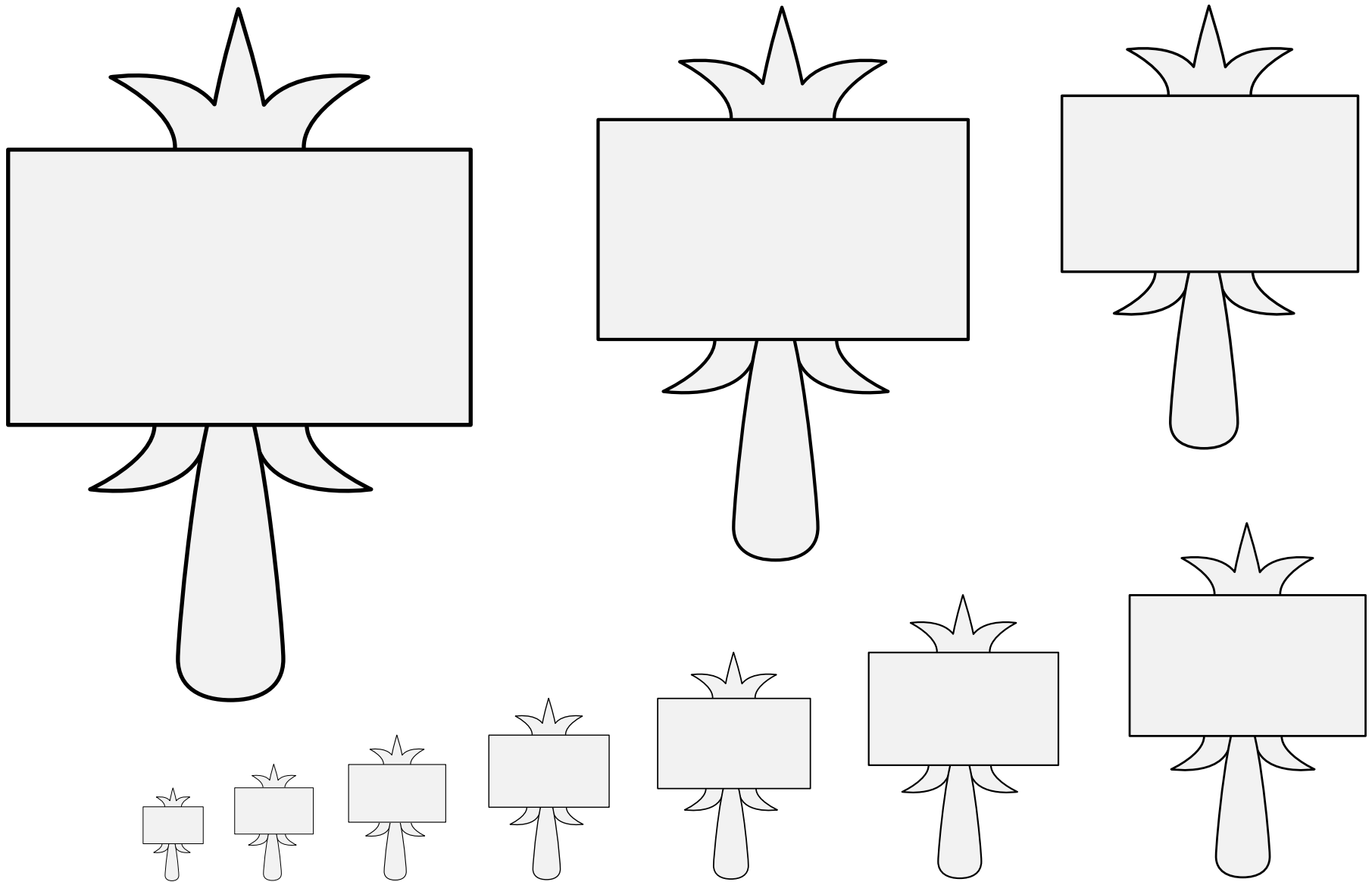

A pounding tool.

Default orientation: head to chief, striking to dexter.
Proper coloration: sable head and brown wood handle.

Source: Beyeren Armorial. Artist: Claes Heinenzoon. (Folio 56v.)

Hammer (7) 16.64

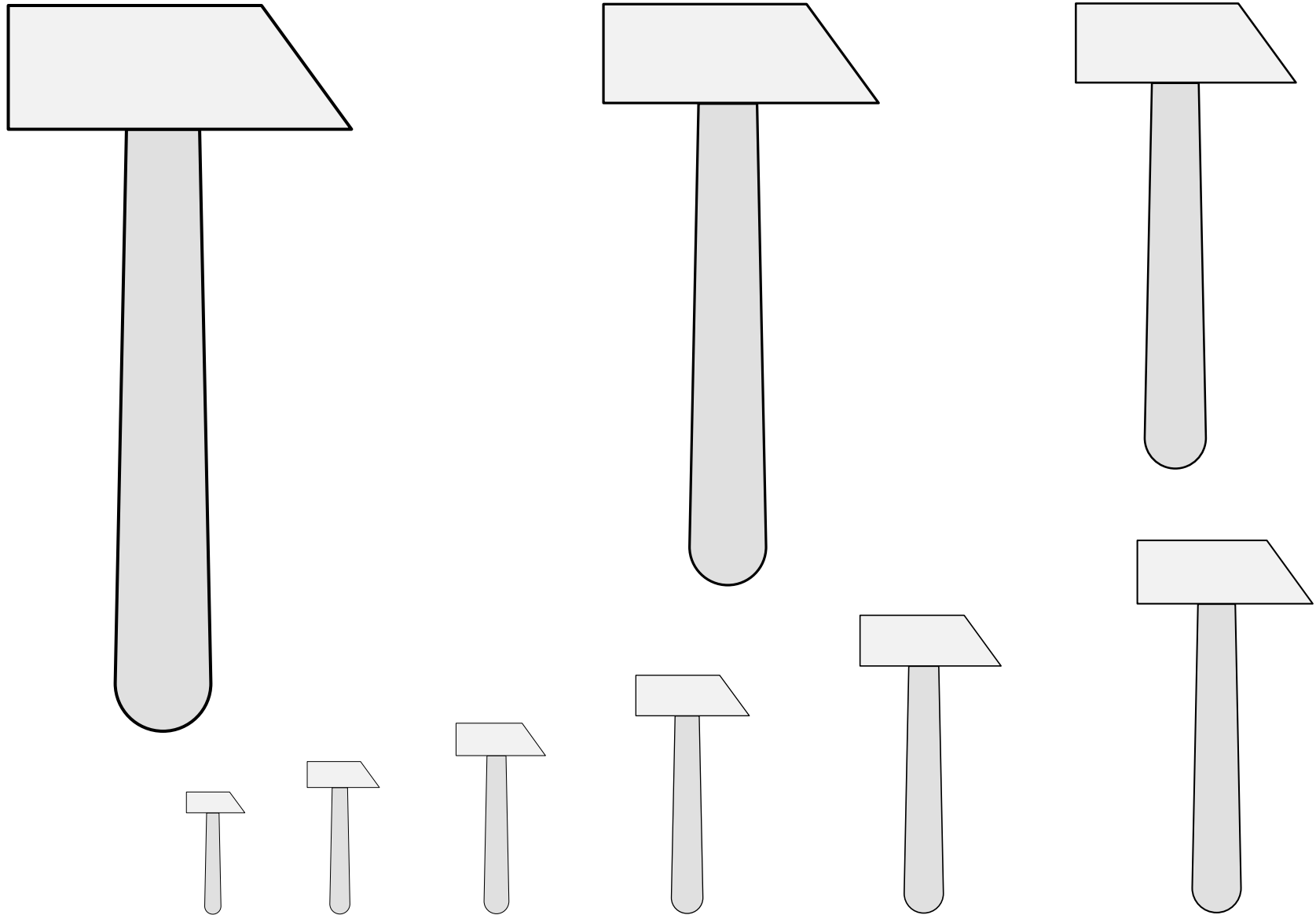

A pounding tool.

Default orientation: head to chief, striking to dexter.

Proper coloration: sable head and brown wood handle.

Hammer (8) 16.65

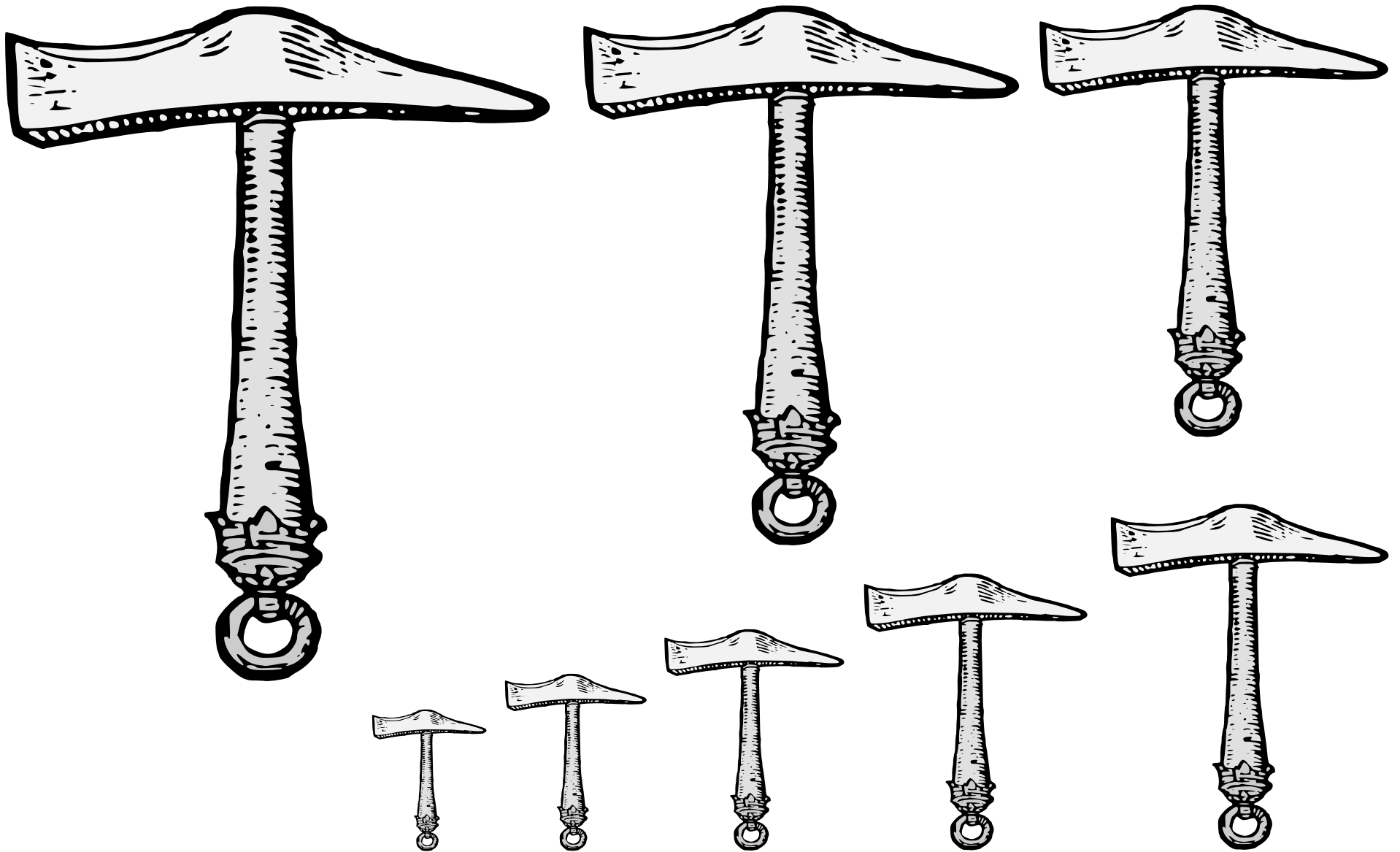

A pounding tool.

Default orientation: head to chief, striking to dexter.

Proper coloration: sable head and brown wood handle.

Source: Le Blason Des Armoiries. Artist: Jérôme de Bara. (Page 62.)

Hammer (9) 16.66

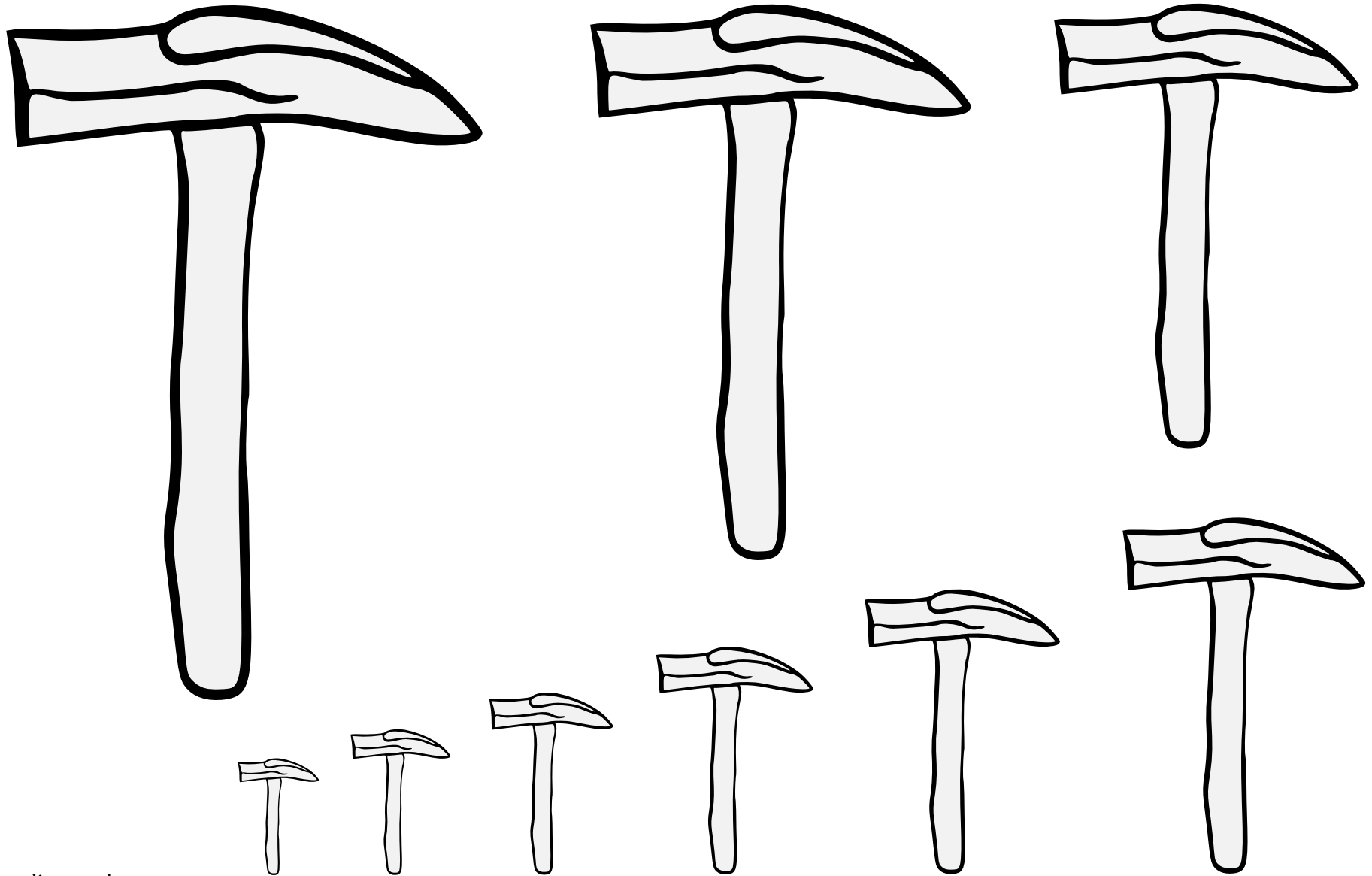

A pounding tool.

Default orientation: head to chief, striking to dexter.

Proper coloration: sable head and brown wood handle.

Source: Die Hausbücher der Nürnberger Zwölfbrüderstiftungen.

Artist unknown. (Mendel I, folio 155v.) Adapted by Thora Brandsdottir.

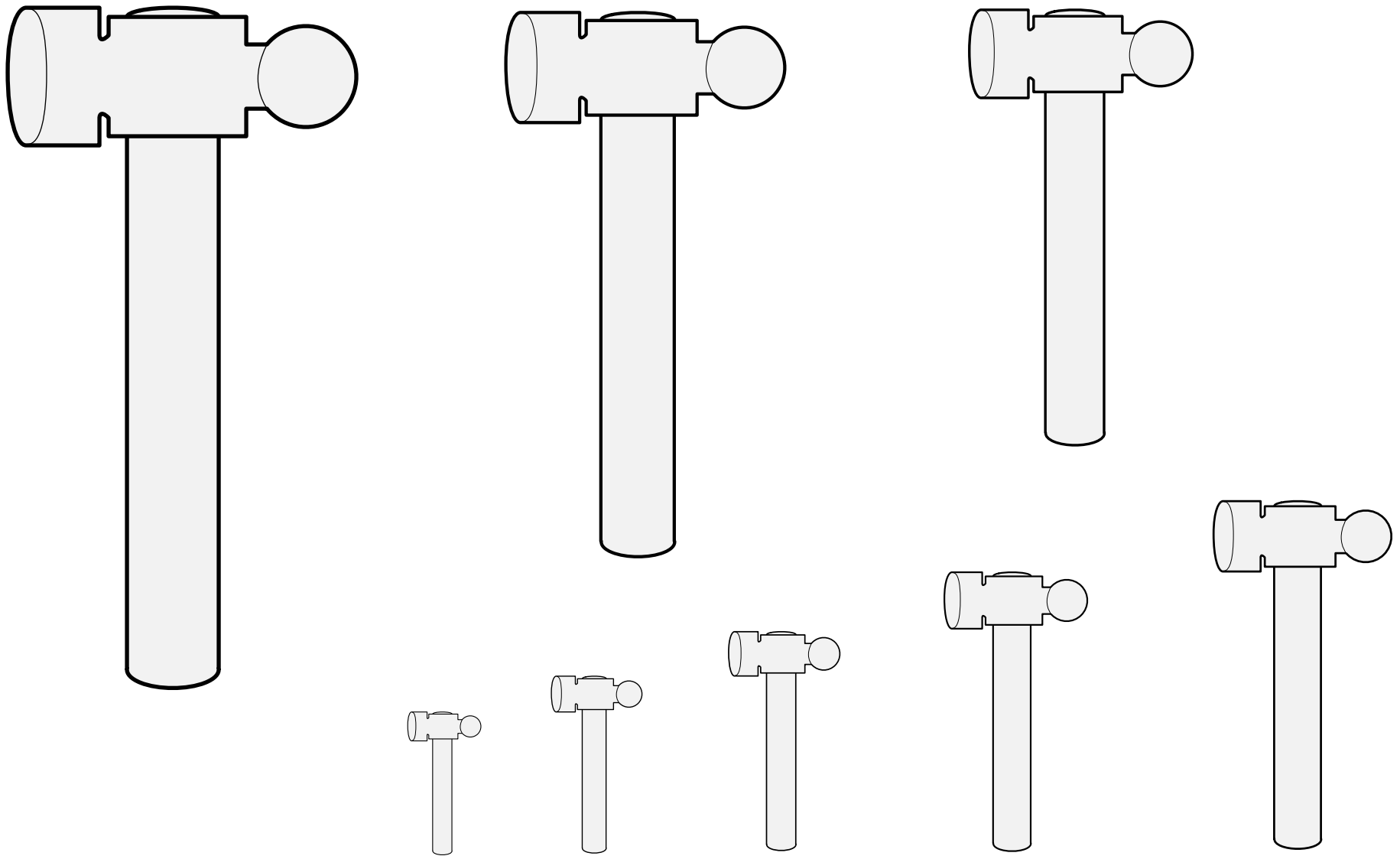

A pounding tool.

Default orientation: head to chief, striking to dexter. Proper coloration: sable head and brown wood handle.

On the July 2021 cover letter it was ruled this charge is unregistrable without documentation of its use in period.

Source: Pennsic Traceable Art. Artist: Unknown.

Adapted by Mathghamhain Ua Ruadháin.

Hammer, Ball-Peen 16.68

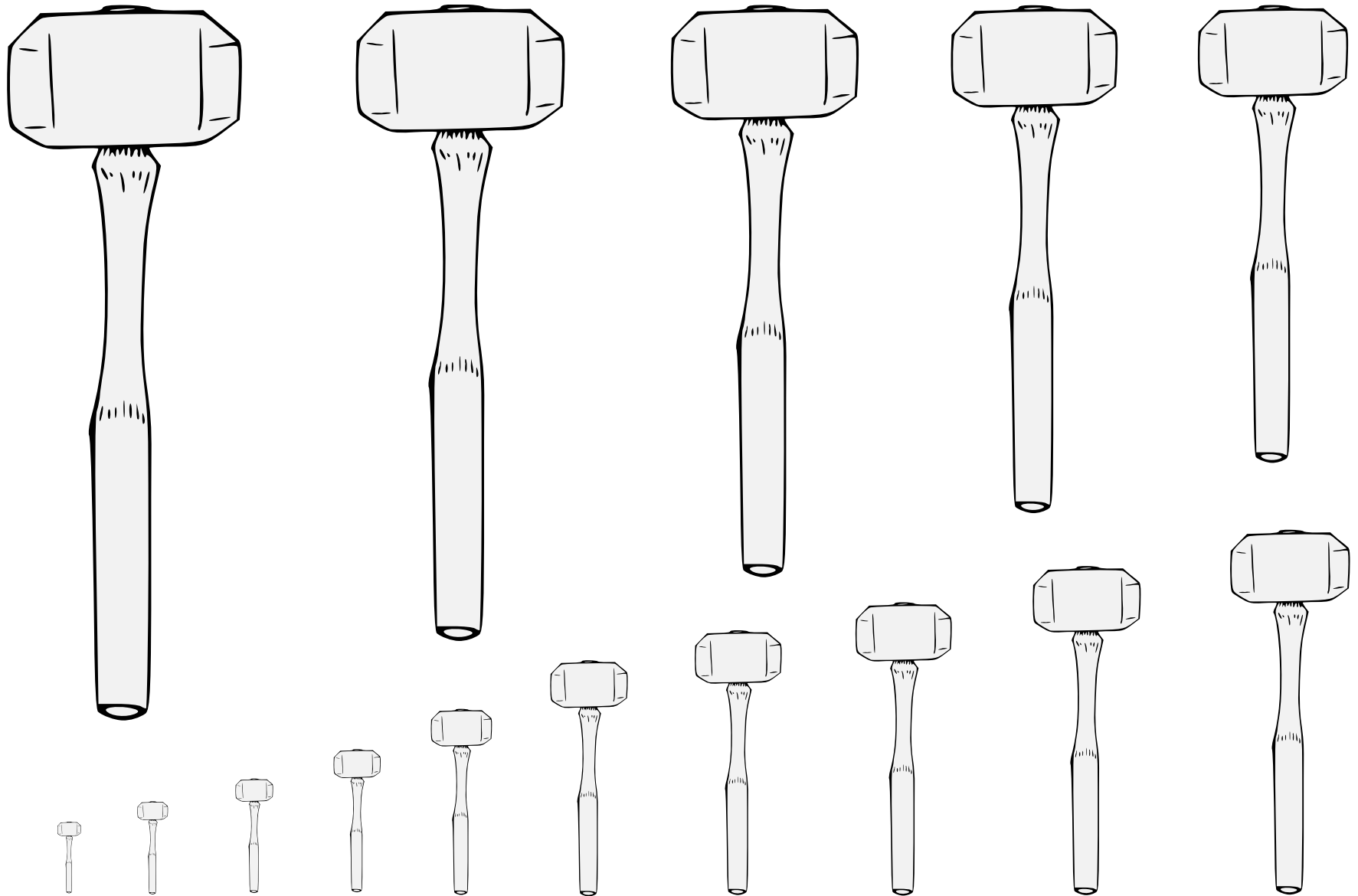

A pounding tool.

Default orientation: head to chief, striking to dexter.

Proper coloration: sable head and brown wood handle.

Source: Heraldic Templates. Artist: Torric inn Björn.

Hammer, Sledge 16.69

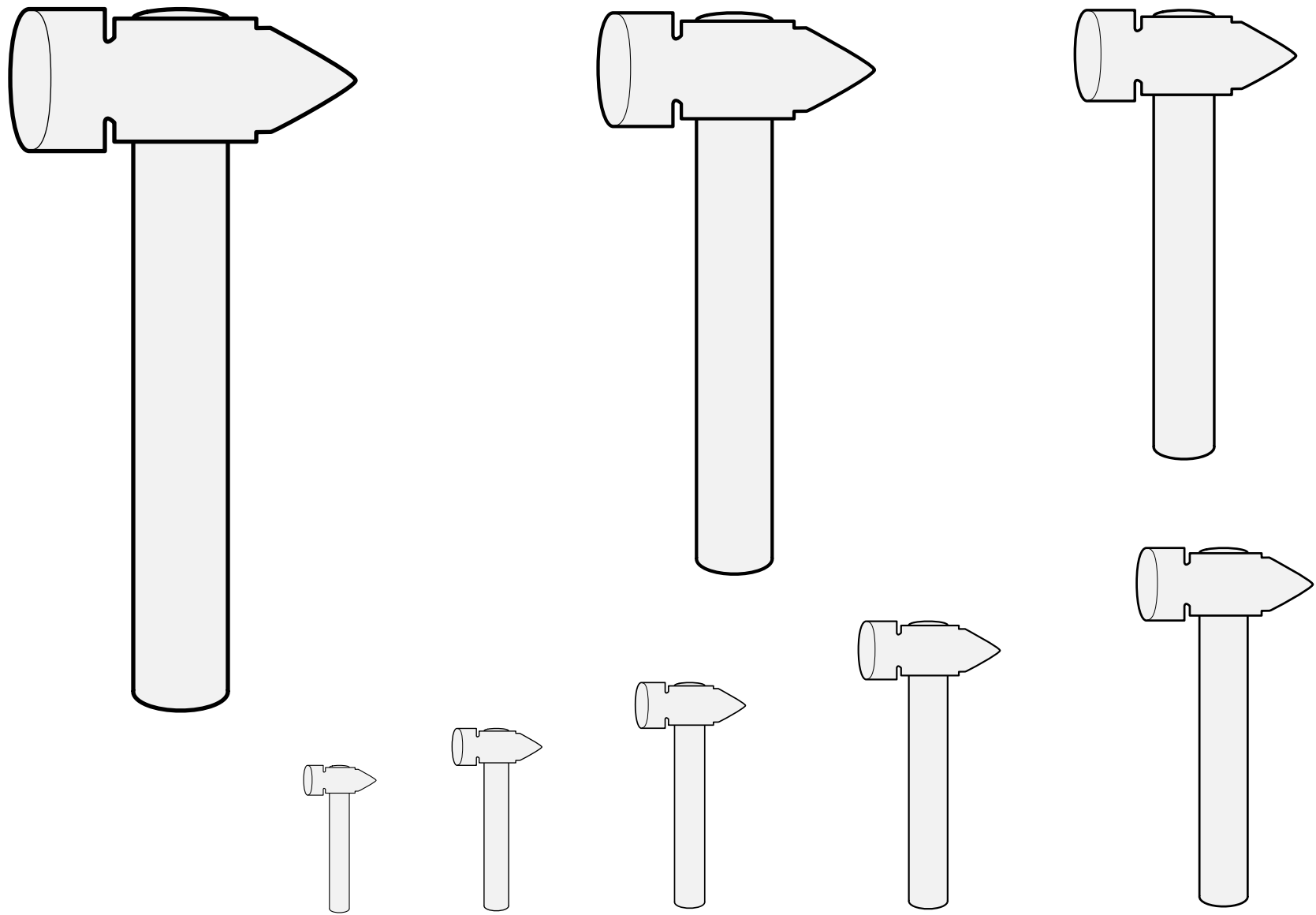

A pounding tool.

Default orientation: head to chief, striking to dexter.

Proper coloration: sable head and brown wood handle.

The smith's hammer can also be blazoned a "cross pean hammer."

Hammer, Smith's 16.70

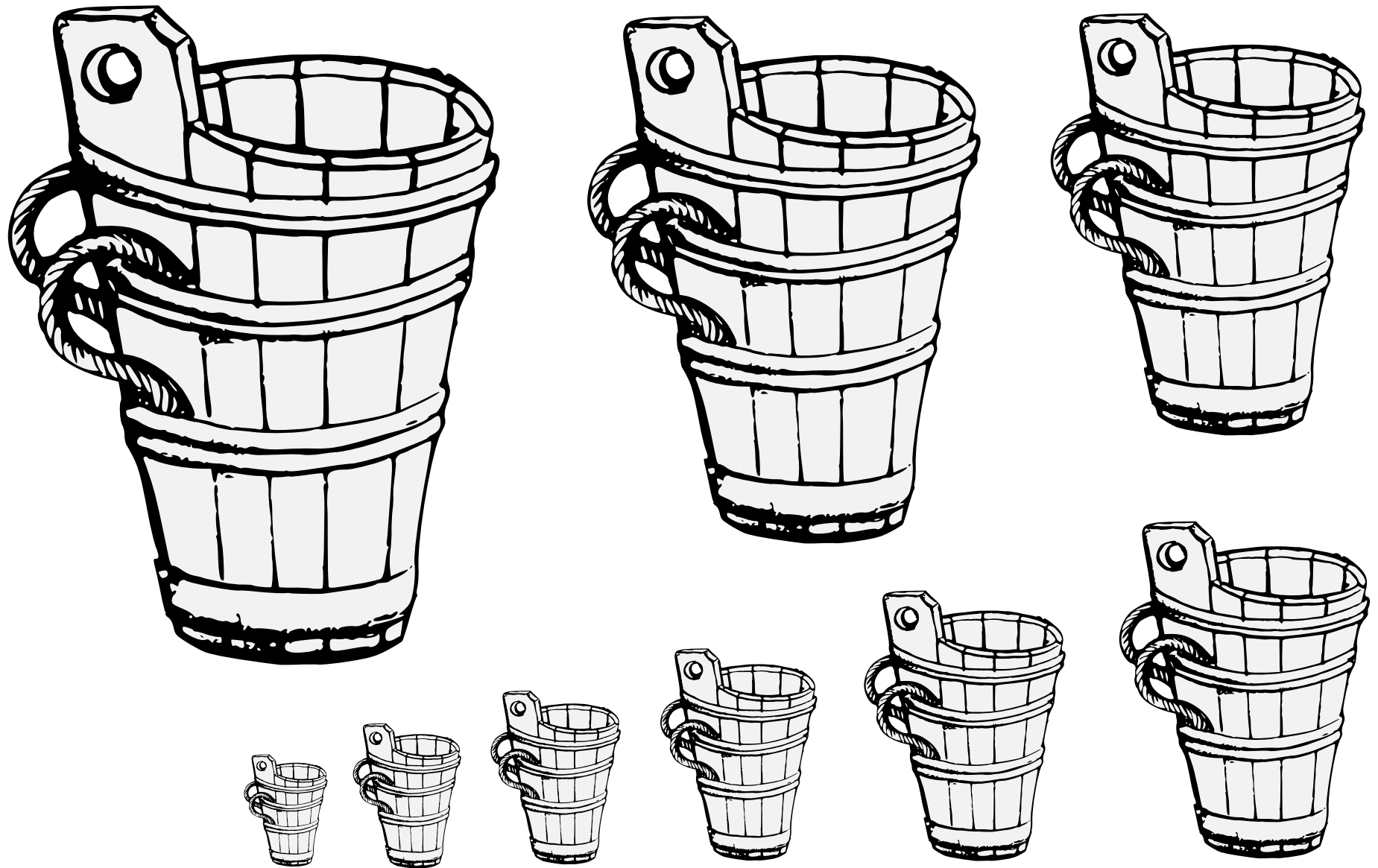

A sturdy bucket with straps allowing it to be carried as a backpack. Used for transport of bricks and other building materials.

Default orientation: palewise, opening to chief. Proper coloration: brown wood.

Source: Scheibler Armorial. Artist: Unknown. (From the arms of Neuenburg.)

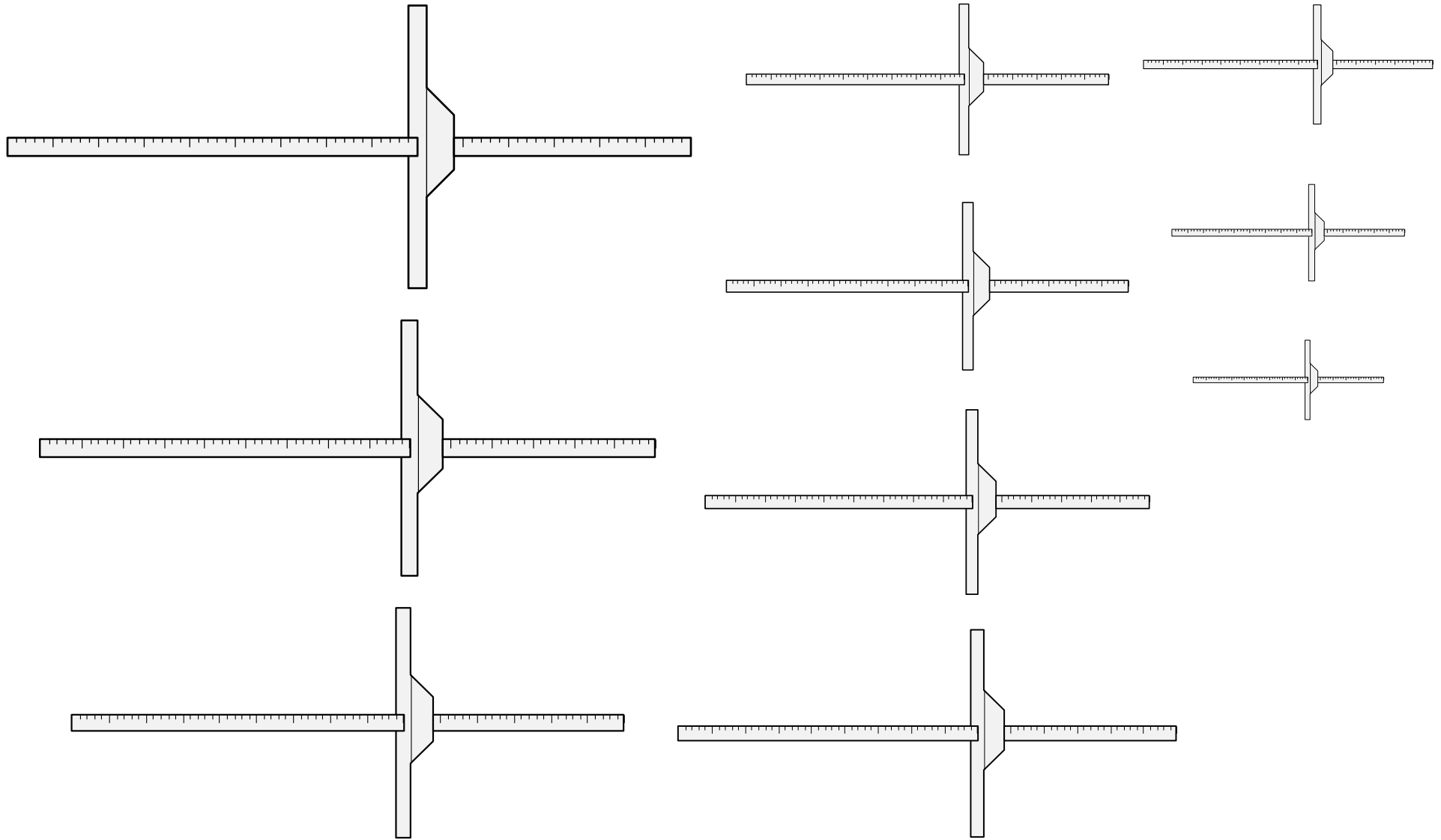

A tool used by surveyers and astronomers to measure angles to distant objects.

Found in the original arms of the Worshipful Company of Plumbers.

Adapted from John Sellers's *Practical Navigation* (1672).

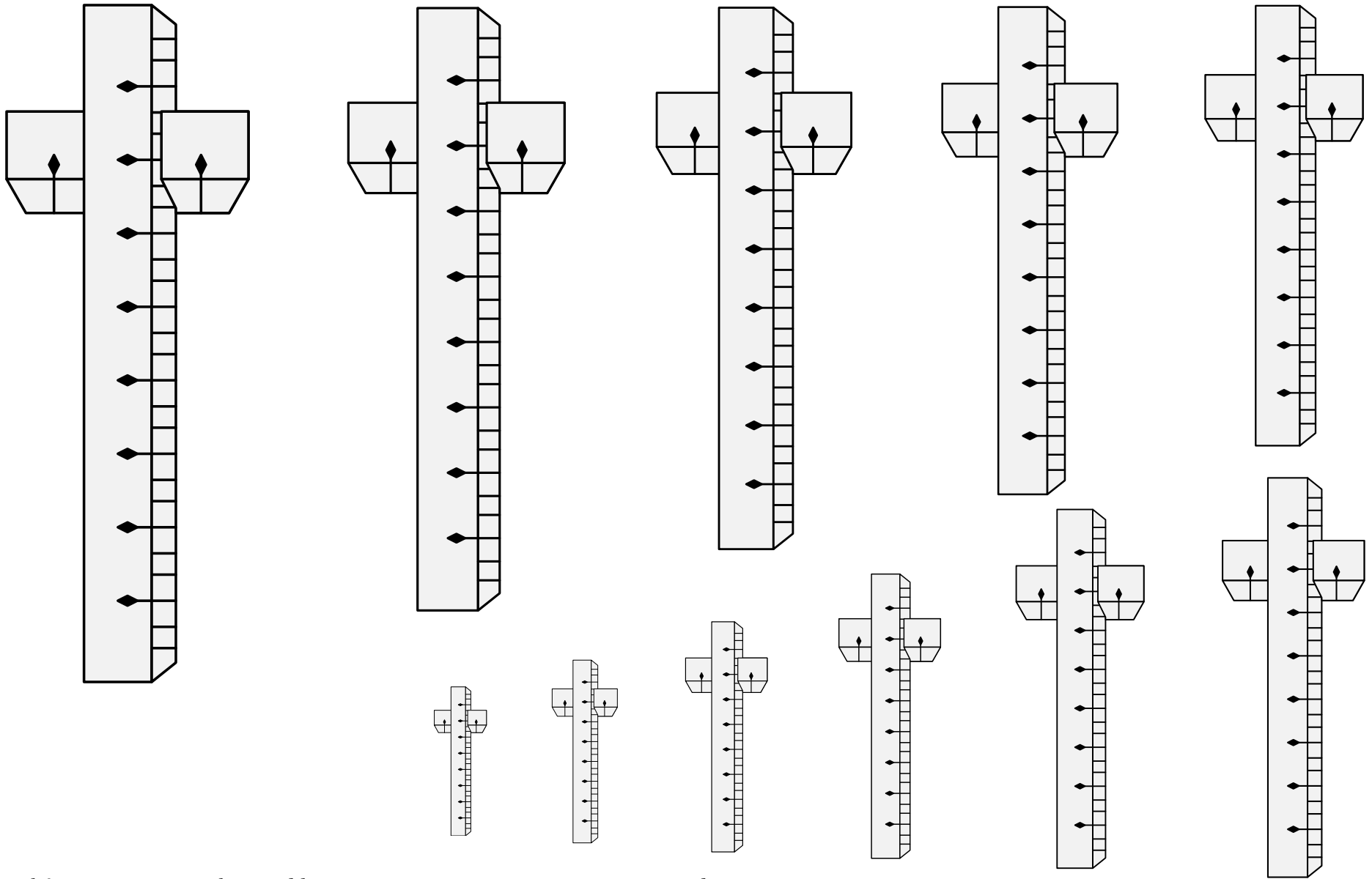

A tool for measuring angles used by surveyors, engineers, astronomers, and navigators.

No default orientation. No proper coloration.

Source: The Armes of All the Cheife Corporatons.
Artist unknown. (Arms of the Company of Plumbers.)

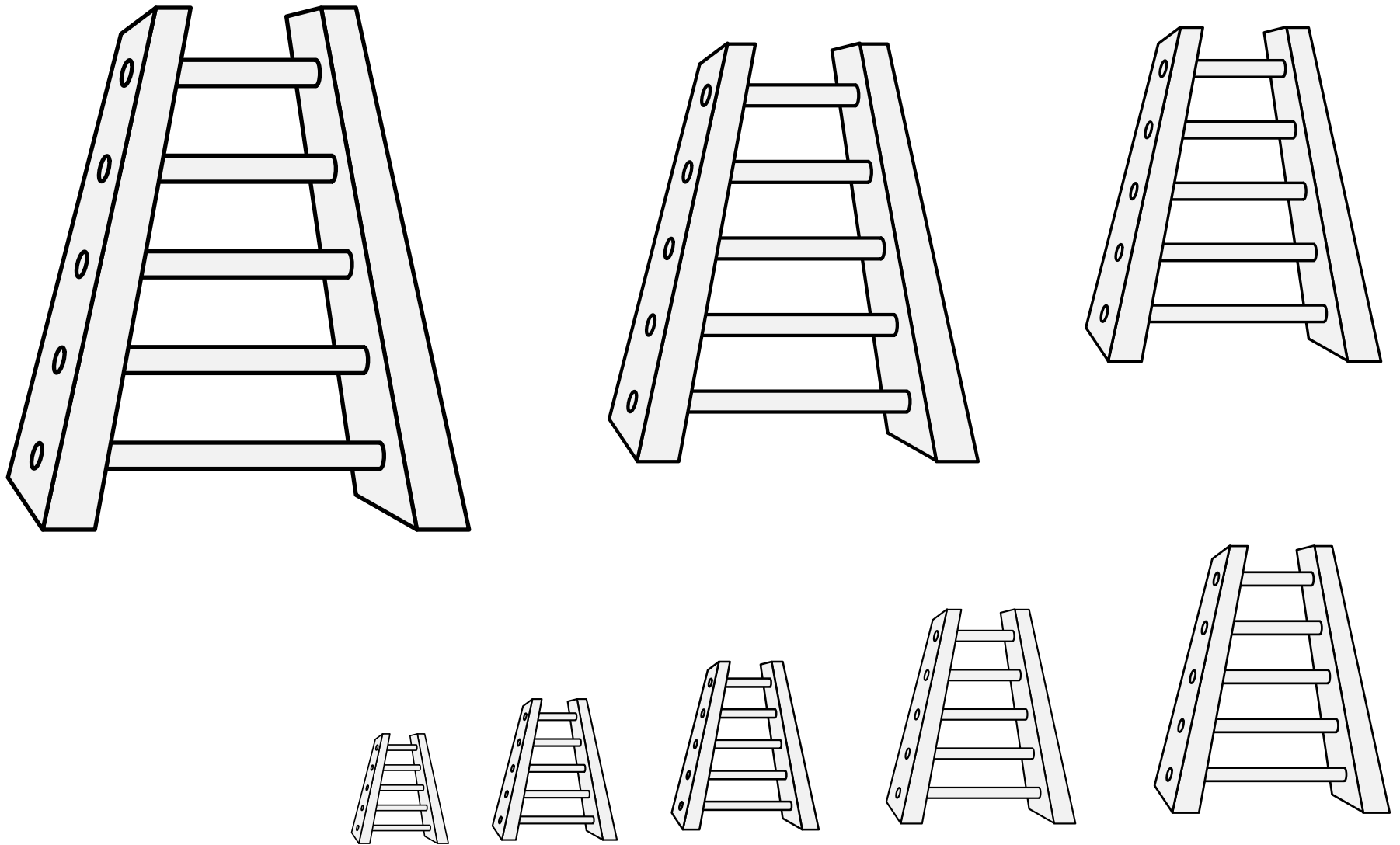

A pair of poles with rungs used for climbing.

Default orientation: upright. No proper coloration.

Source: De Ministrerio Armorum. (Arms of Bartholomeus de la scala.) Artist unknown.

Ladder (1) 16.74

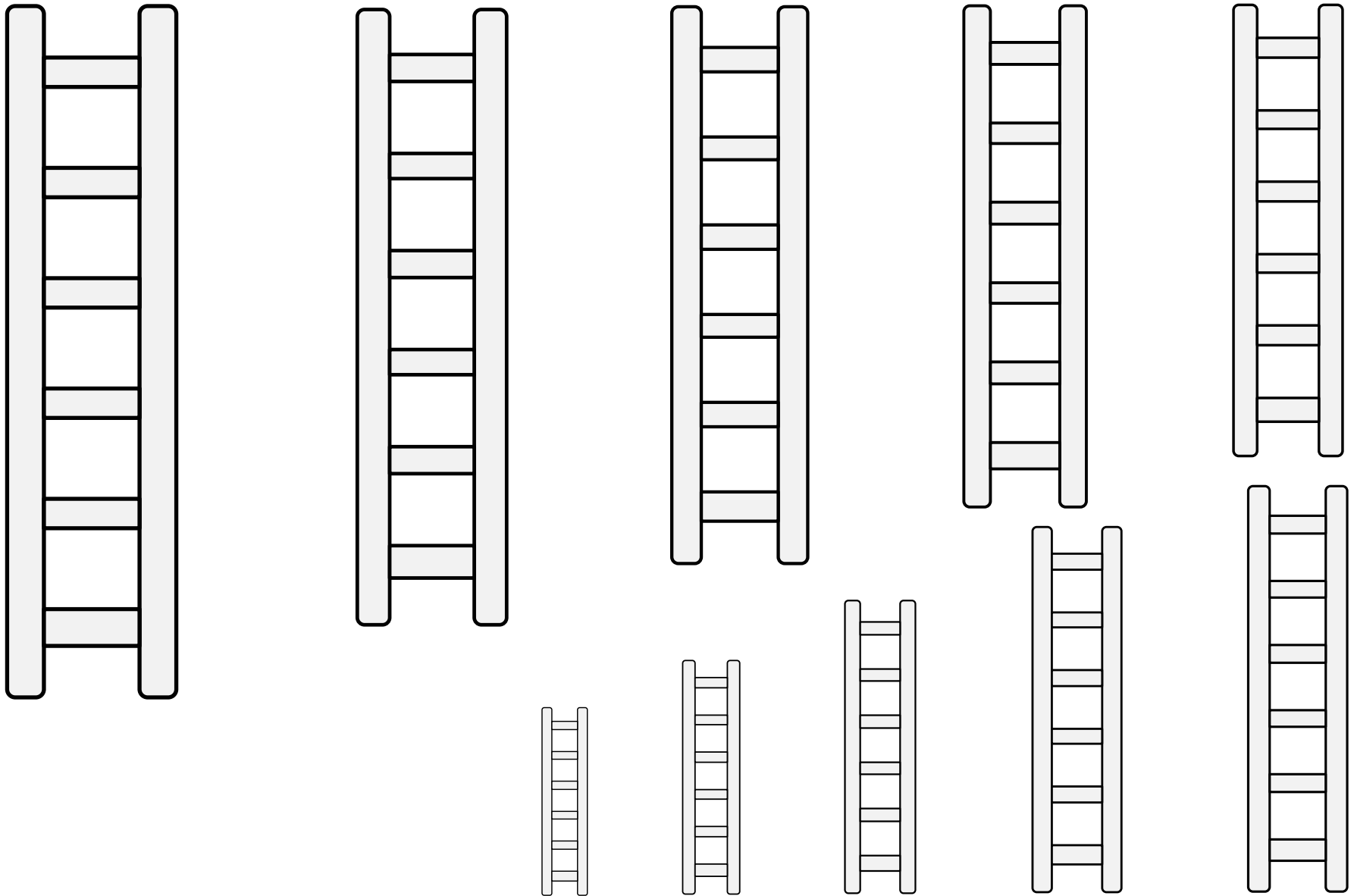

A pair of poles with rungs used for climbing.

Default orientation: upright. No proper coloration.

Source: Zurich Roll. Artist unknown. Adapted by Mathghamhain Ua Ruadháin.

Ladder (2) 🍷 16.75

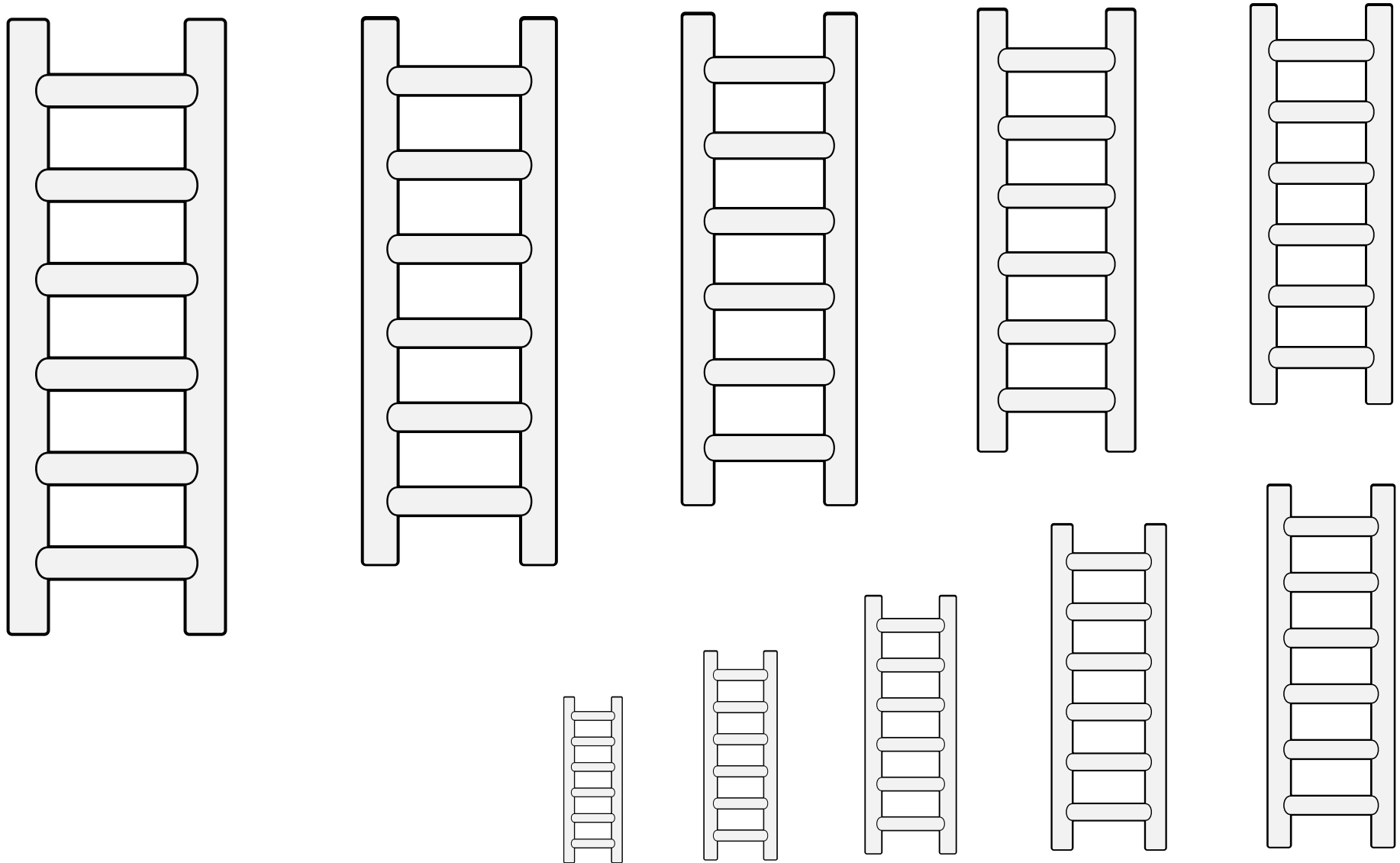

A pair of poles with rungs used for climbing.
Default orientation: upright. No proper coloration.

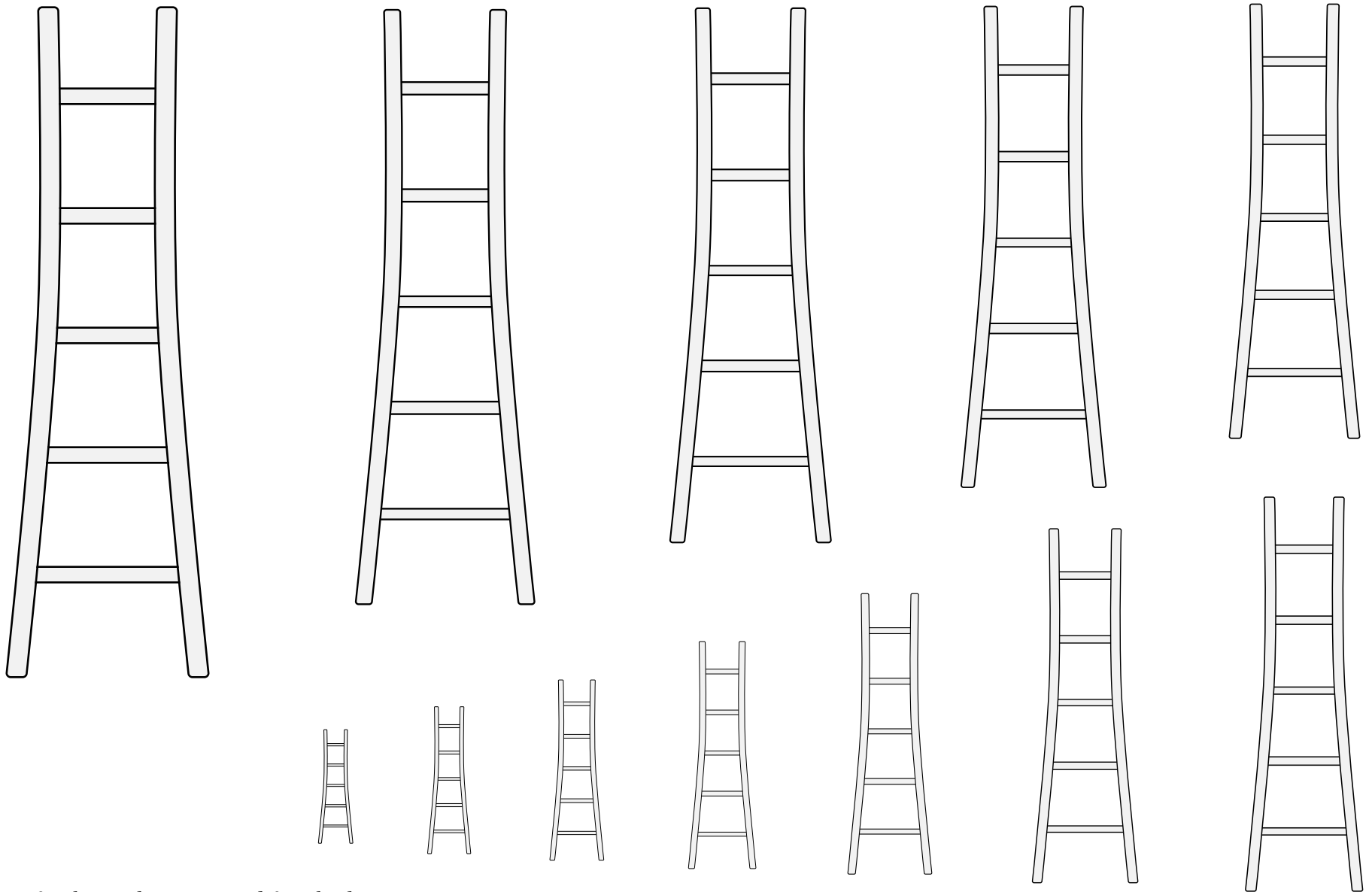

A pair of poles with rungs used for climbing.

Default orientation: upright. No proper coloration.

Source: Nobiliario de Armas de Valencia, Aragón y Cataluña.
Artist unknown. (Folio 35r.)

Ladder (4) 16.77

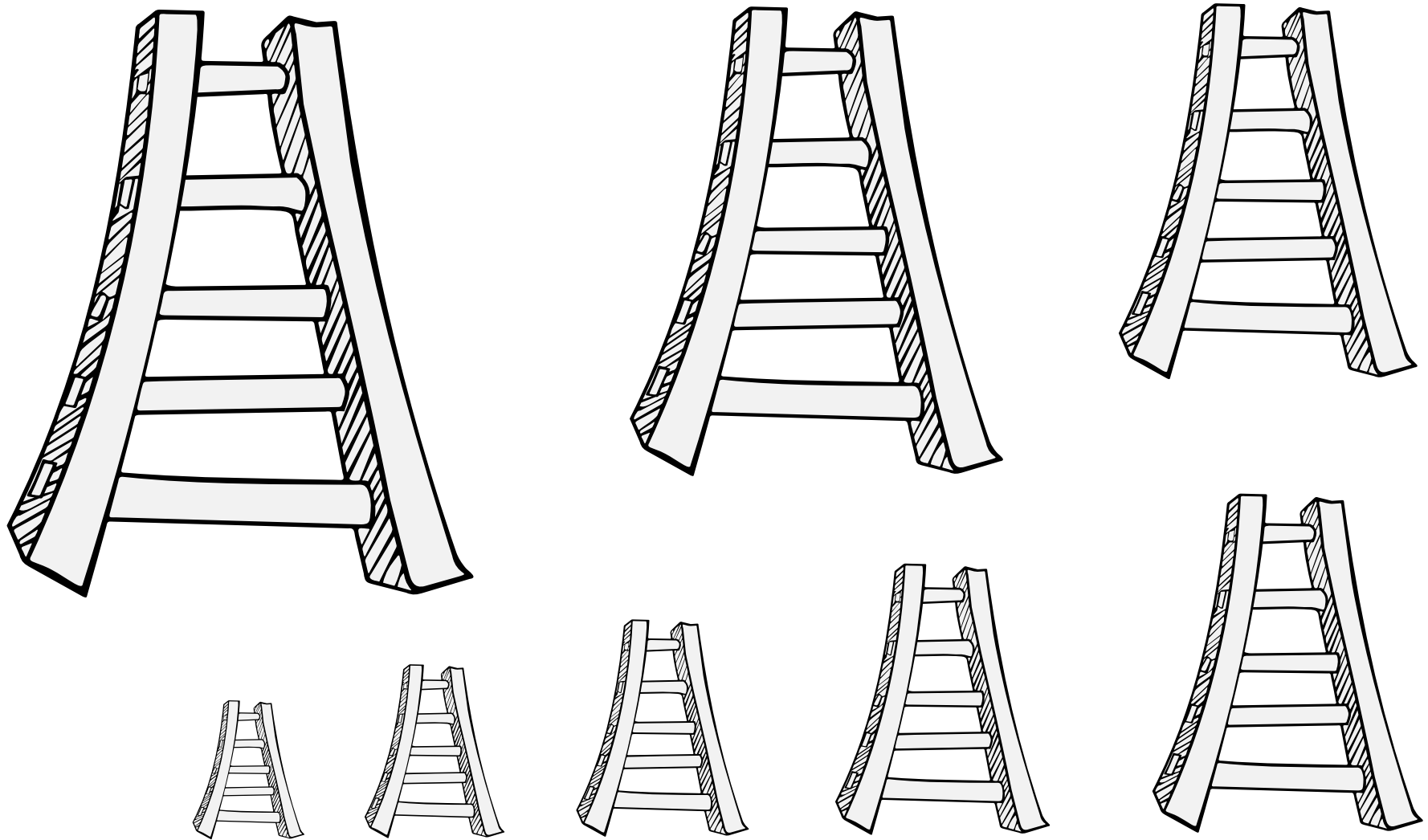

A pair of poles with rungs used for climbing.

Default orientation: upright. No proper coloration.

Source: Lambeth MS774. Artist unknown. Adapted by Vémundr Syvursson.

Ladder (5) 16.78

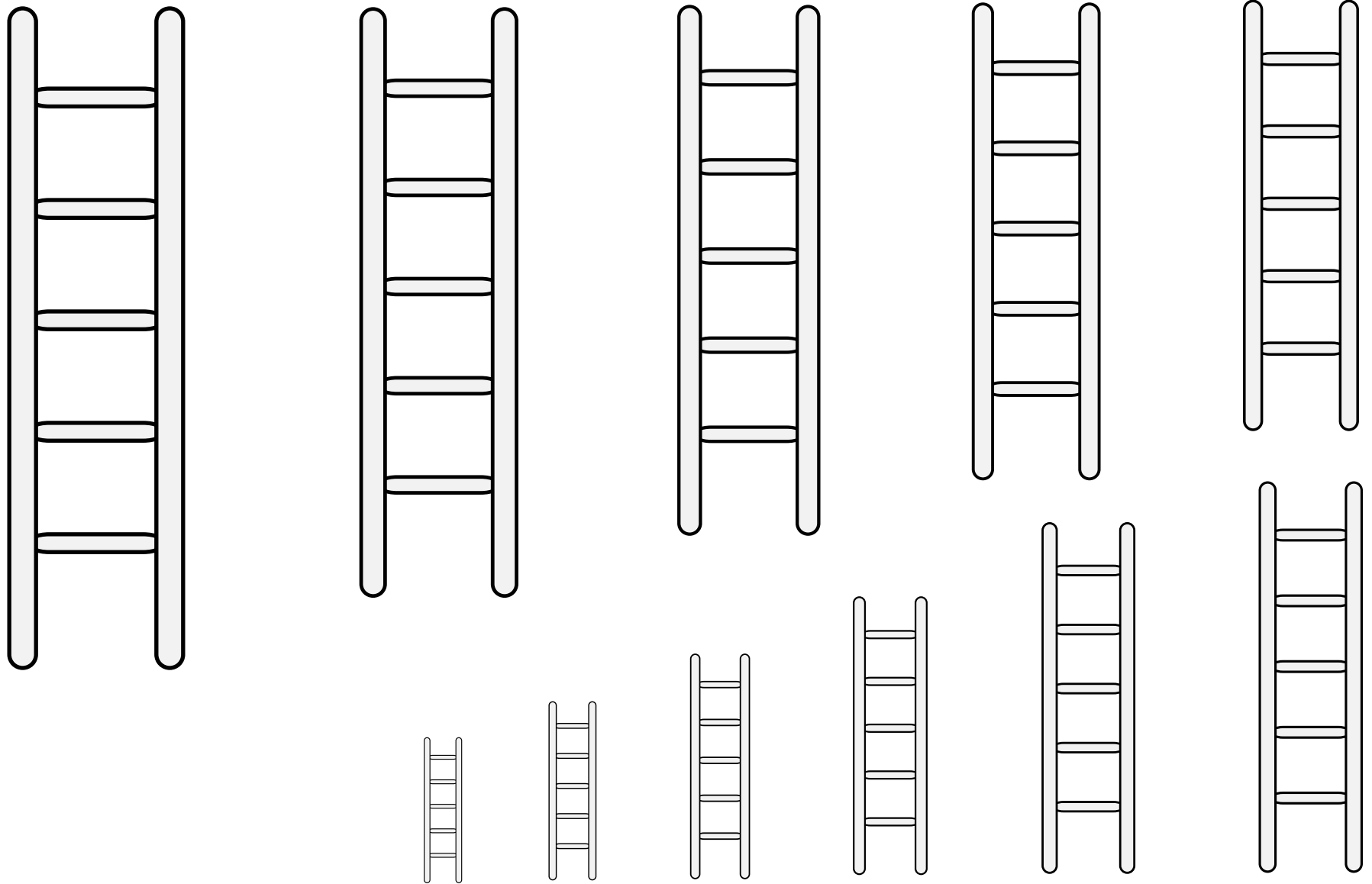

A pair of poles with rungs used for climbing.

Default orientation: upright. No proper coloration.

Source: Wernigerode Armorial. Artist unknown. (Folio 250r.)

Ladder (6) 16.79

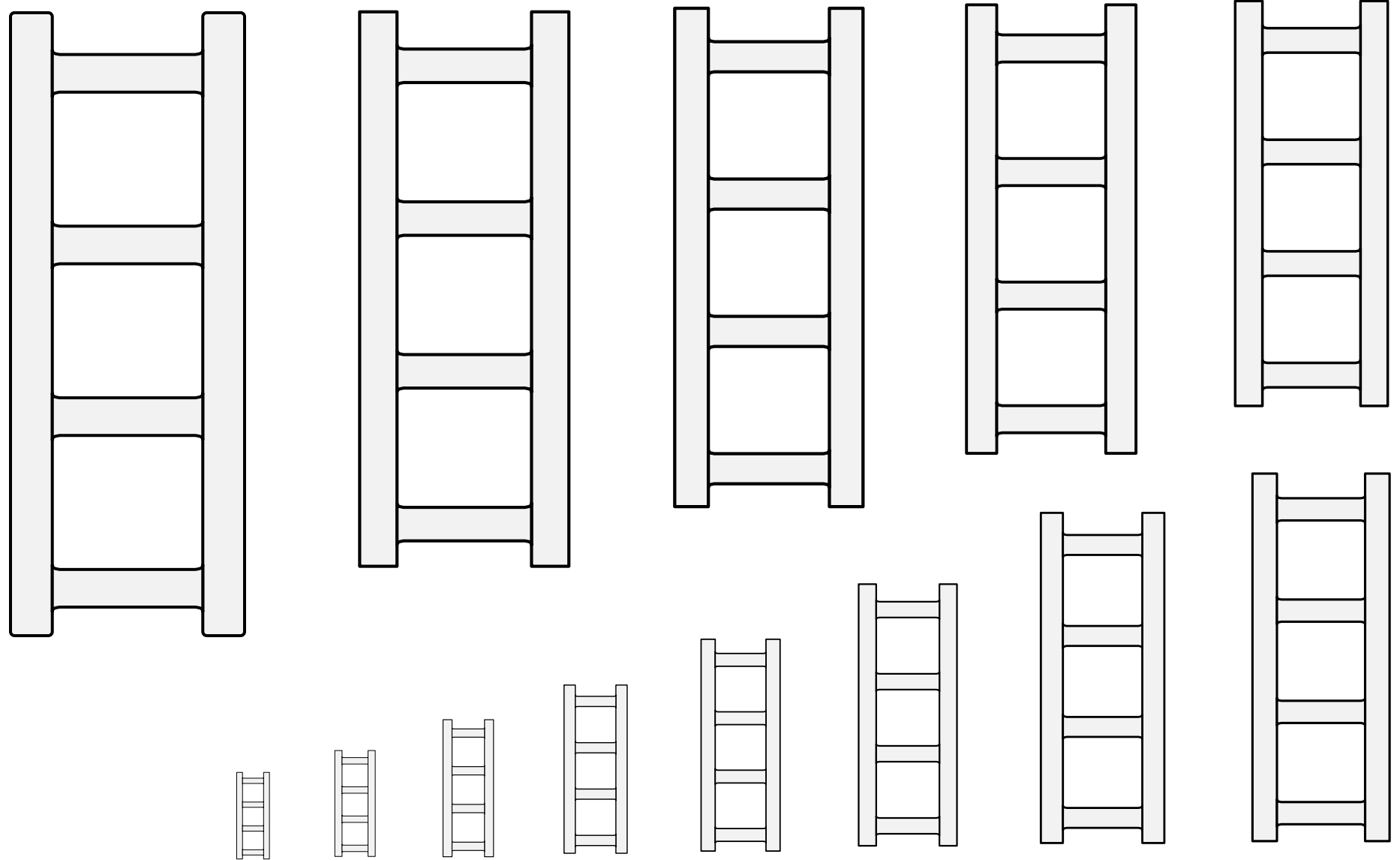

A pair of poles with rungs used for climbing.

Default orientation: upright. No proper coloration.

Artist unknown. Adapted from an image of the arms of Ramon d'Escales in the Cathedral of Barcelona.

Ladder (7) 16.80

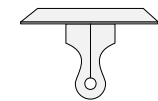
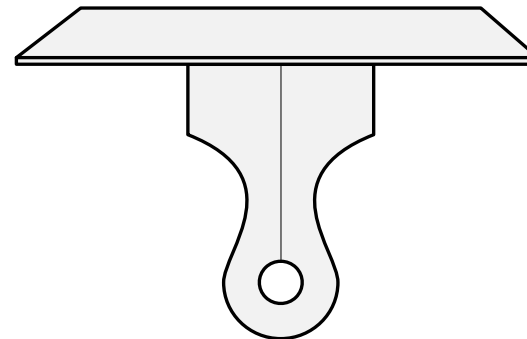
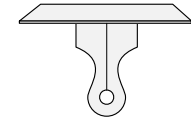
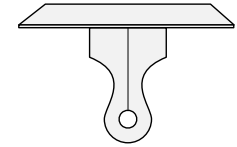
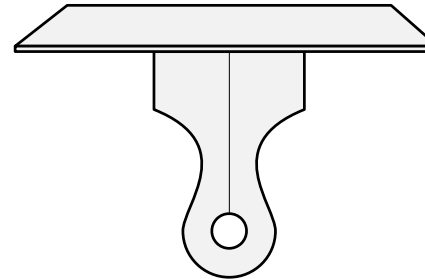
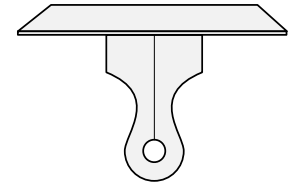
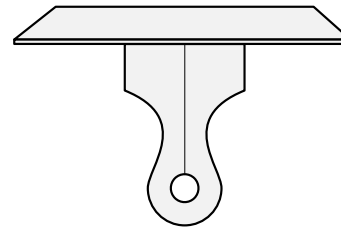
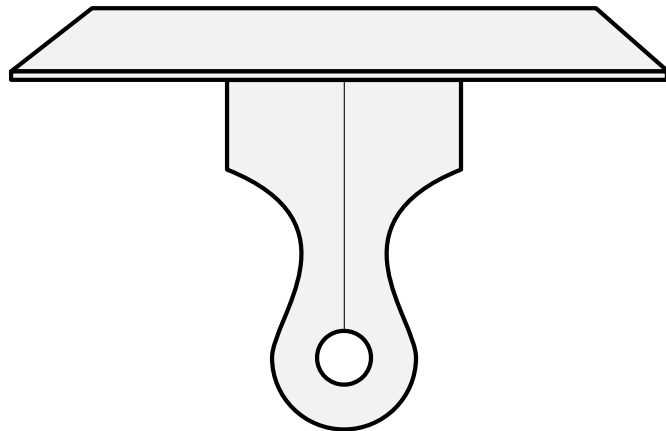
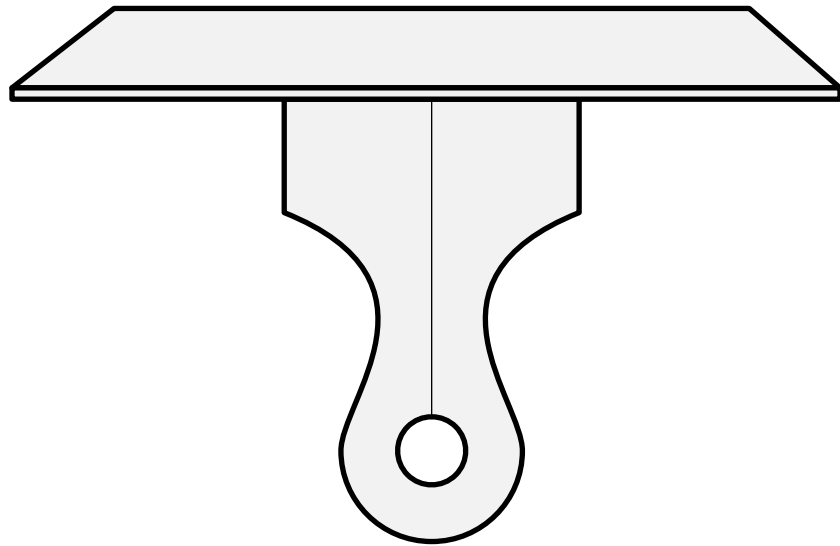

A builder's tool for ensuring surfaces are horizontal or vertical.

Default orientaiton: plane to chief, loop to base. No proper coloration.

Adapted from depictions of the original arms of the Worshipful Company of Plumbers.

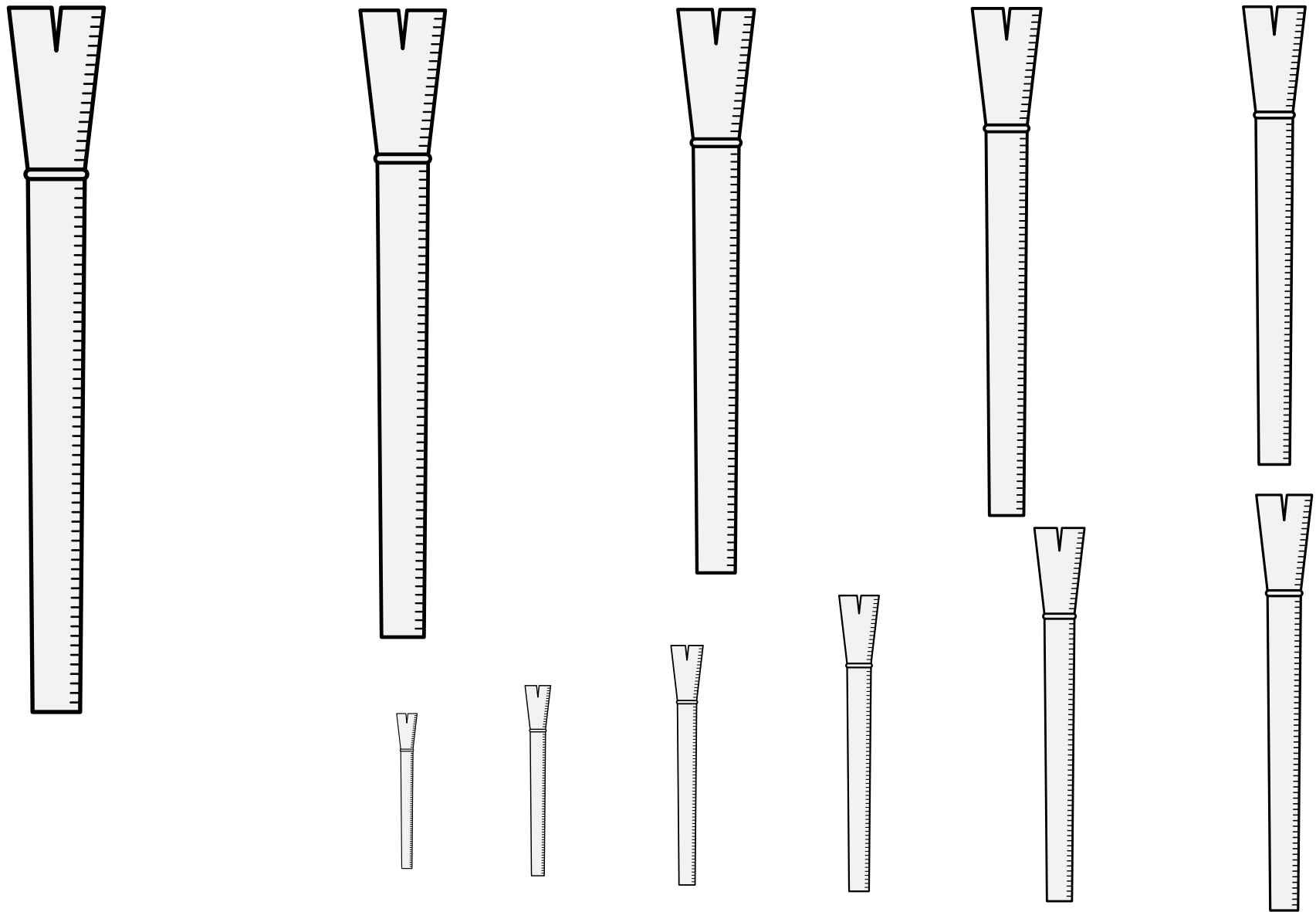

A specialized tool used to stir and rake crushed limestone while baking it to create mortar and cement.

Default orientation: tines to chief. No proper coloration.

Source: Siebmacher's Wappenbuch of 1605. Artist: Johann Siebmacher.
(Arms of Kalckreuter, plate 64.)

Lime Kiln Fork 16.82

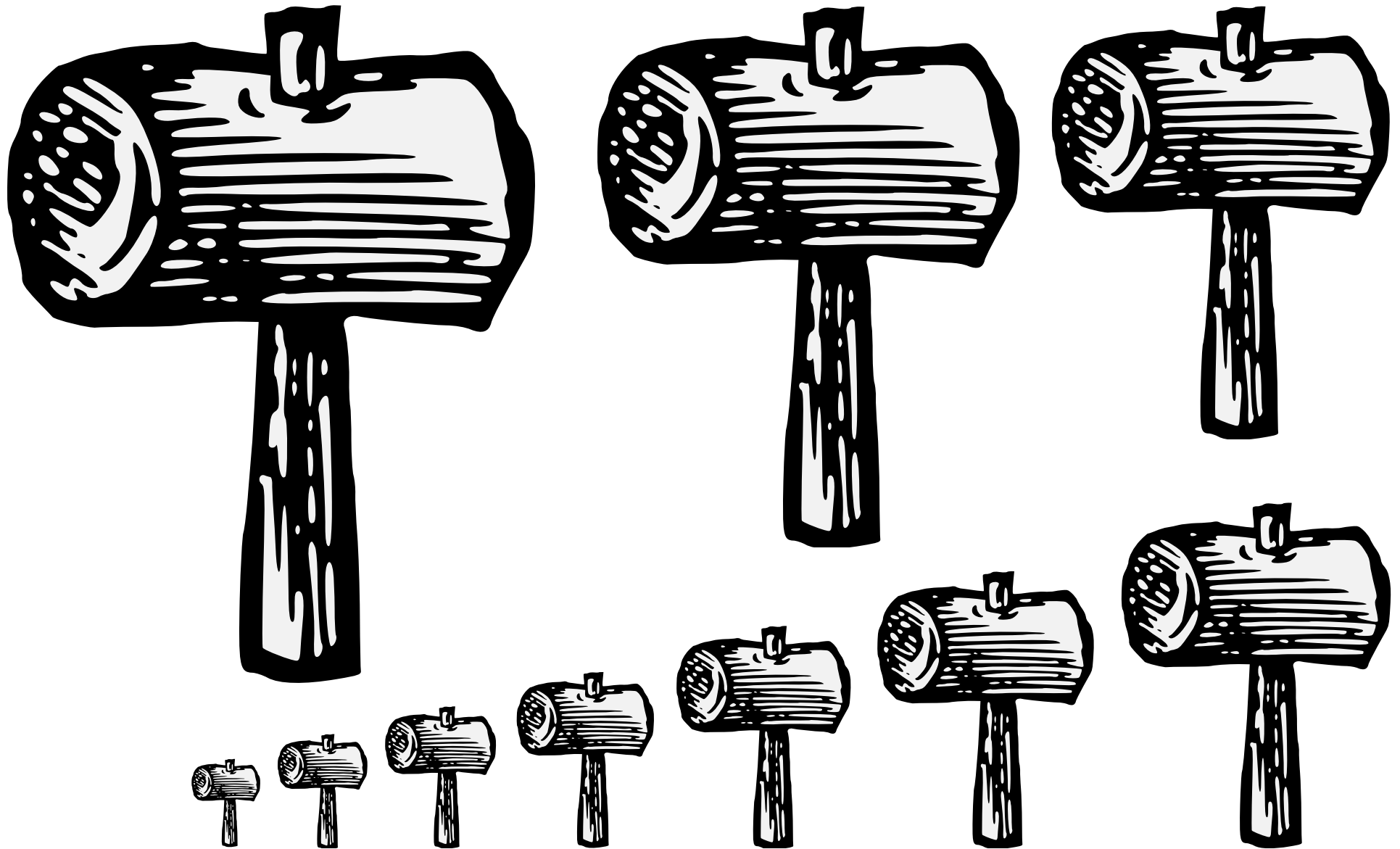

A heavy hammer.

Default orientation: head to chief, striking to dexter.

Proper coloration: sable head and brown wood handle.

Source: Guillim's Display of Heraldry. Artist unknown.

Mallet (1) 16.83

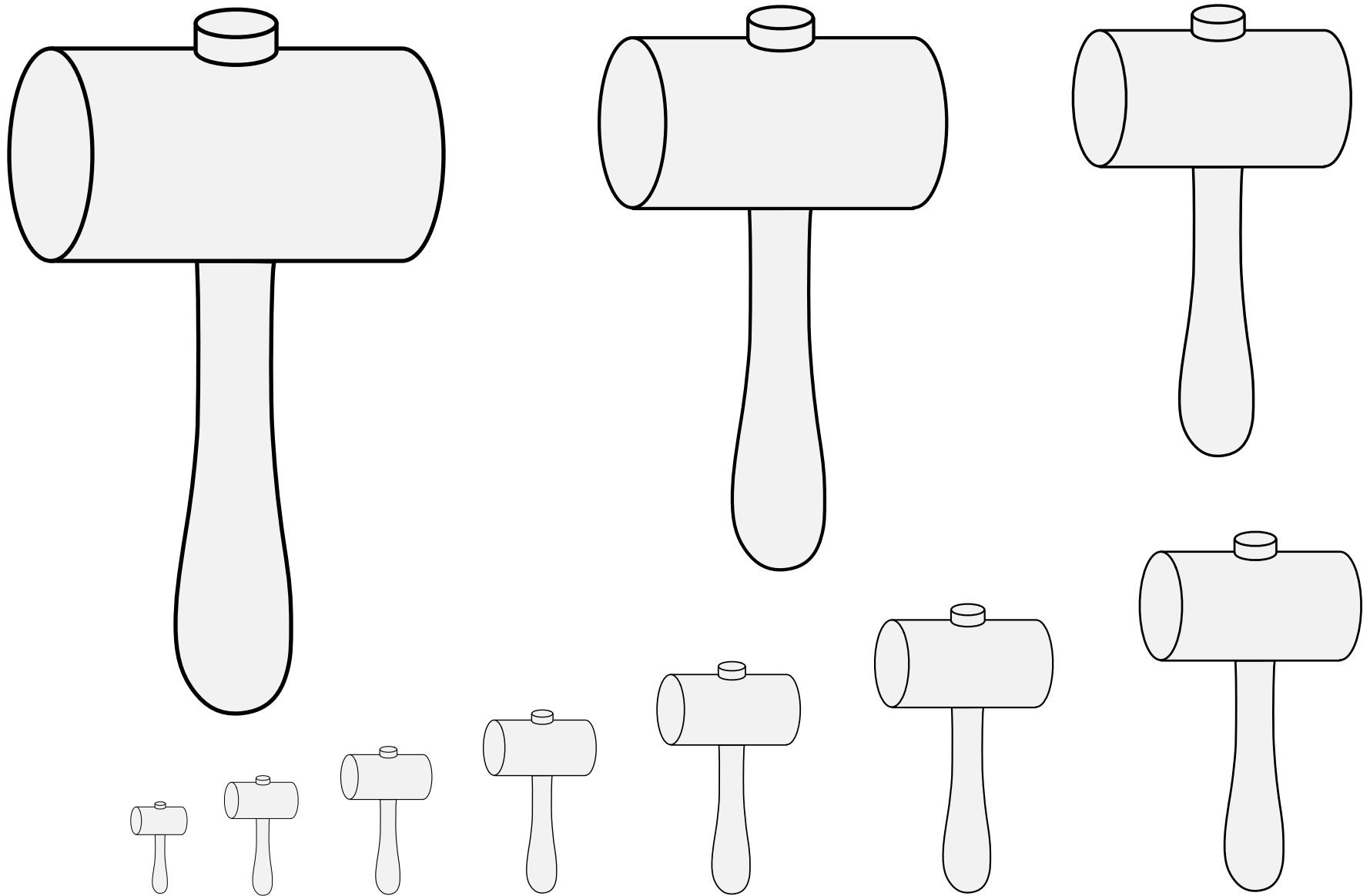

A heavy hammer.

Default orientation: head to chief, striking to dexter.
Proper coloration: sable head and brown wood handle.

Proper coloration: sable head and brown wood handle.

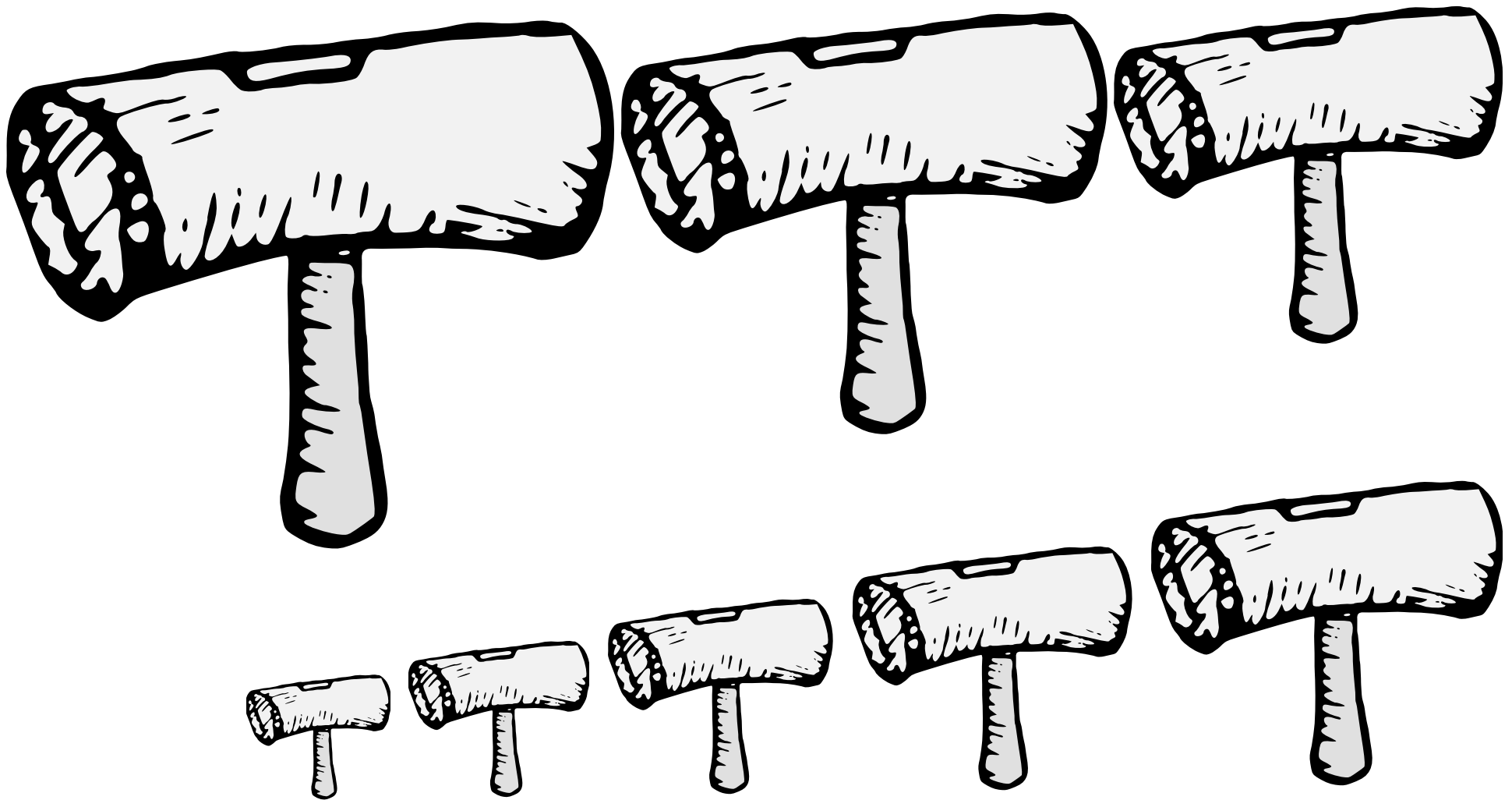

A heavy hammer.

Default orientation: head to chief, striking to dexter.
Proper coloration: sable head and brown wood handle.

Source: Nobleza del Andaluzia. Artist unknown.
(Arms of Bracamonte, folio 211r.)

Mallet (3) 16.85

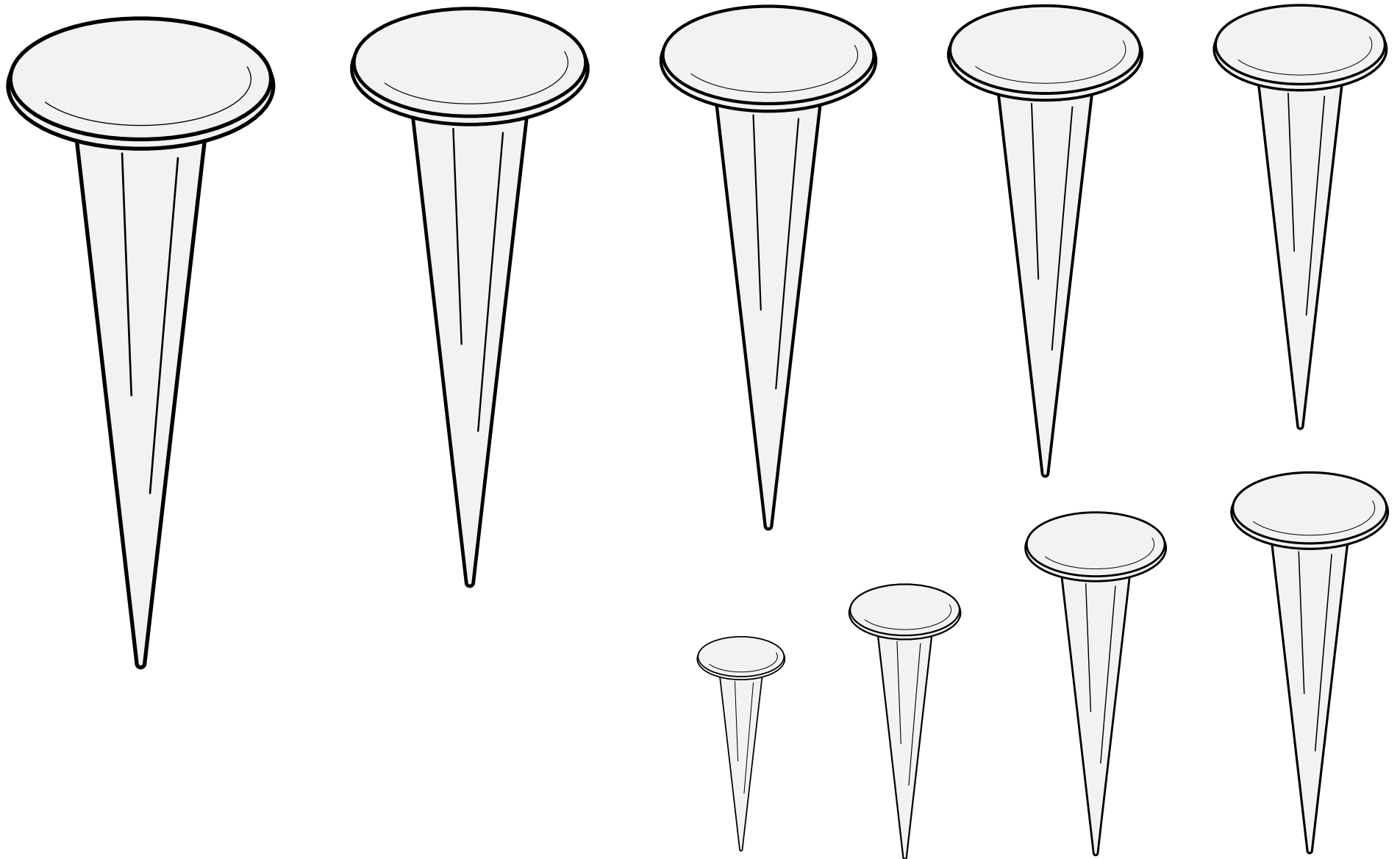

A glaziers nail.

Default alignment: palewise, point to base. No proper coloration.

Source: Insignia Venetorum Nobilium II. Artist unknown.
(From the arms of Boche, folio 67.)

Nail, Closing (1) 16.86

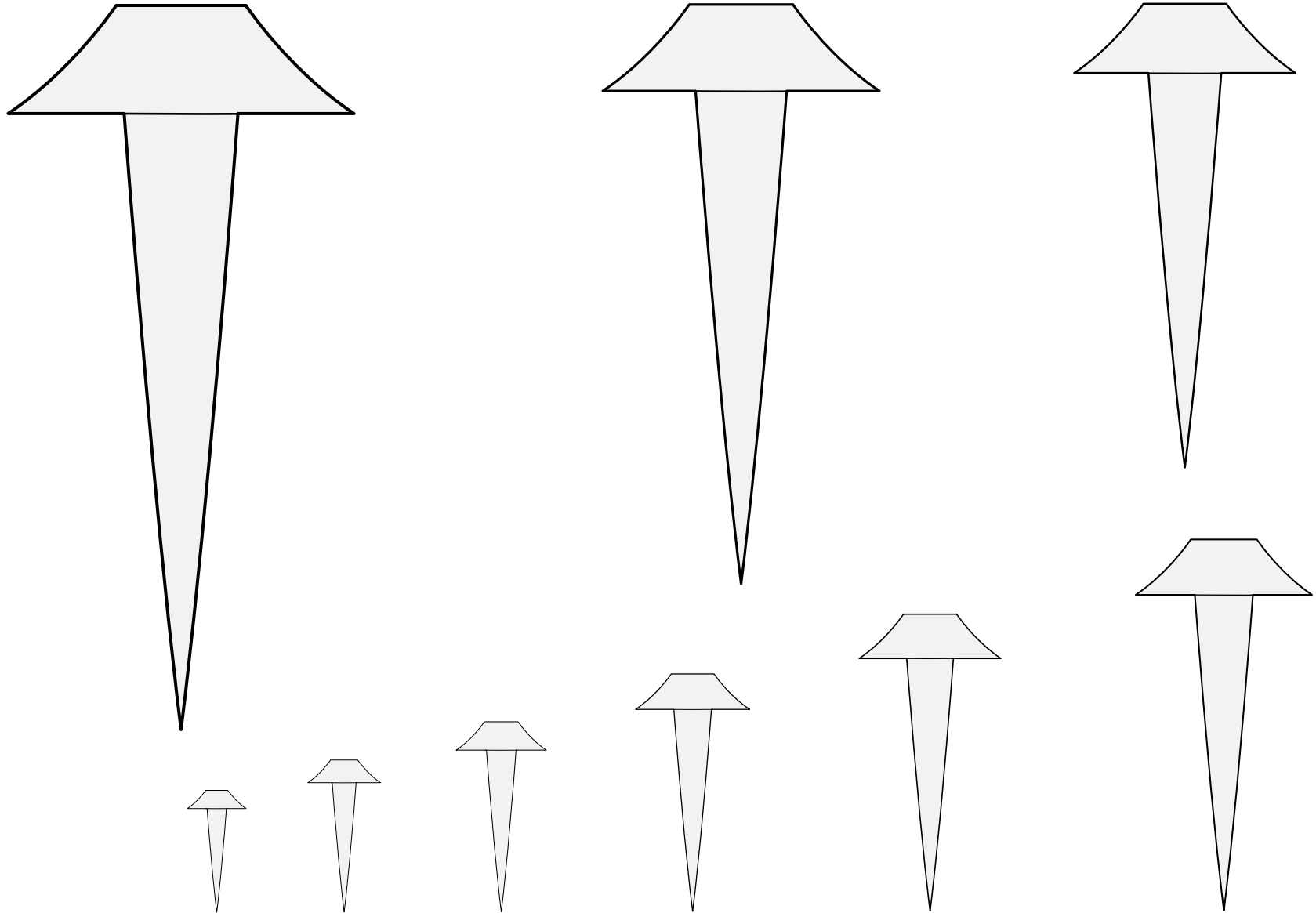

A glaziers nail.

Default alignment: palewise, point to base. No proper coloration.

Source: Wappenbuch der Arlberg-Bruderschaft.
Artist: Vigil Raber. (Folio 16r, arms of Nagele.)

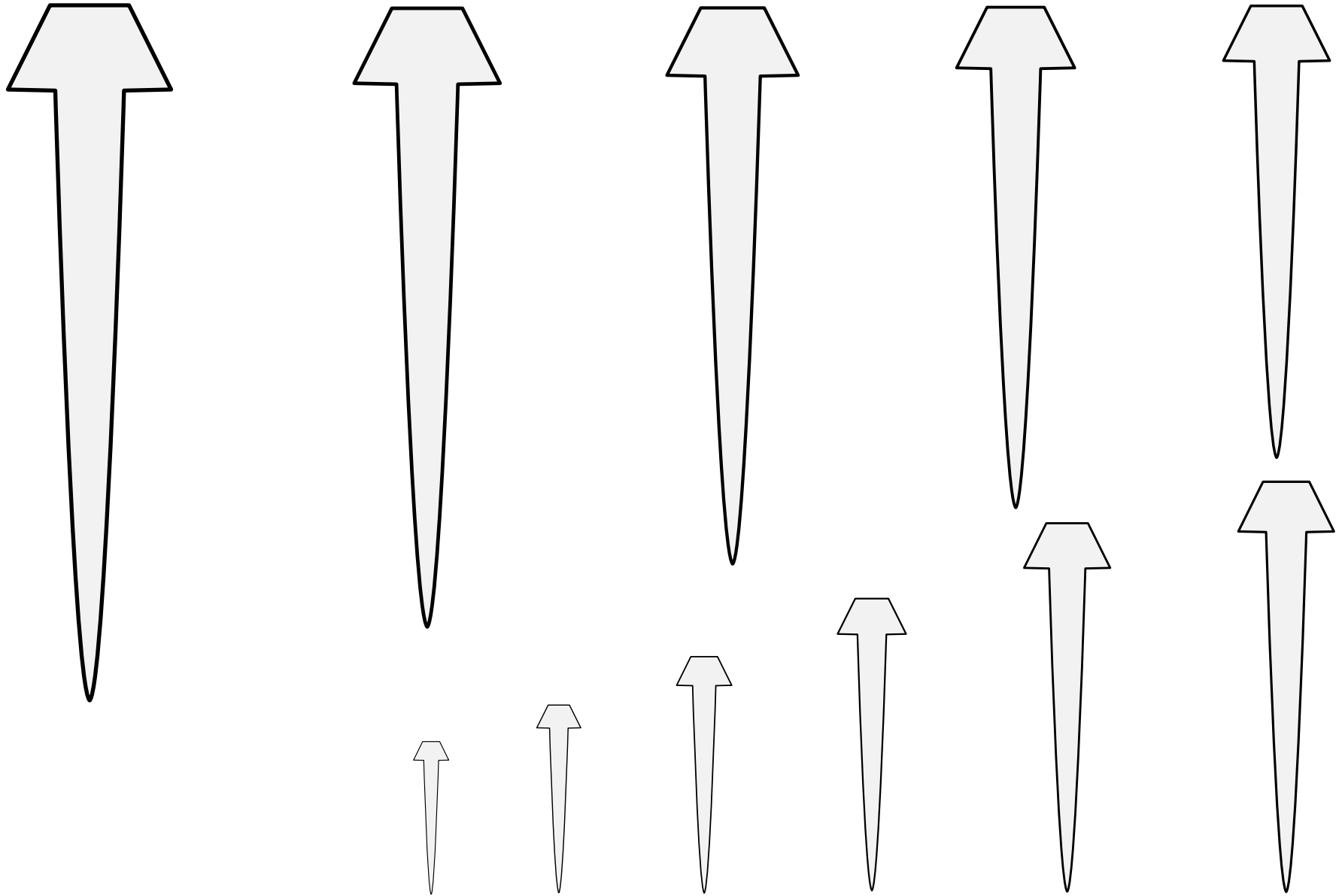

A glaziers nail.

Default alignment: palewise, point to base. No proper coloration.

Source: Sammelband Mehrerer Wappenbücher. Artist unknown. (Folio 30v.)

Nail, Closing (3) 16.88

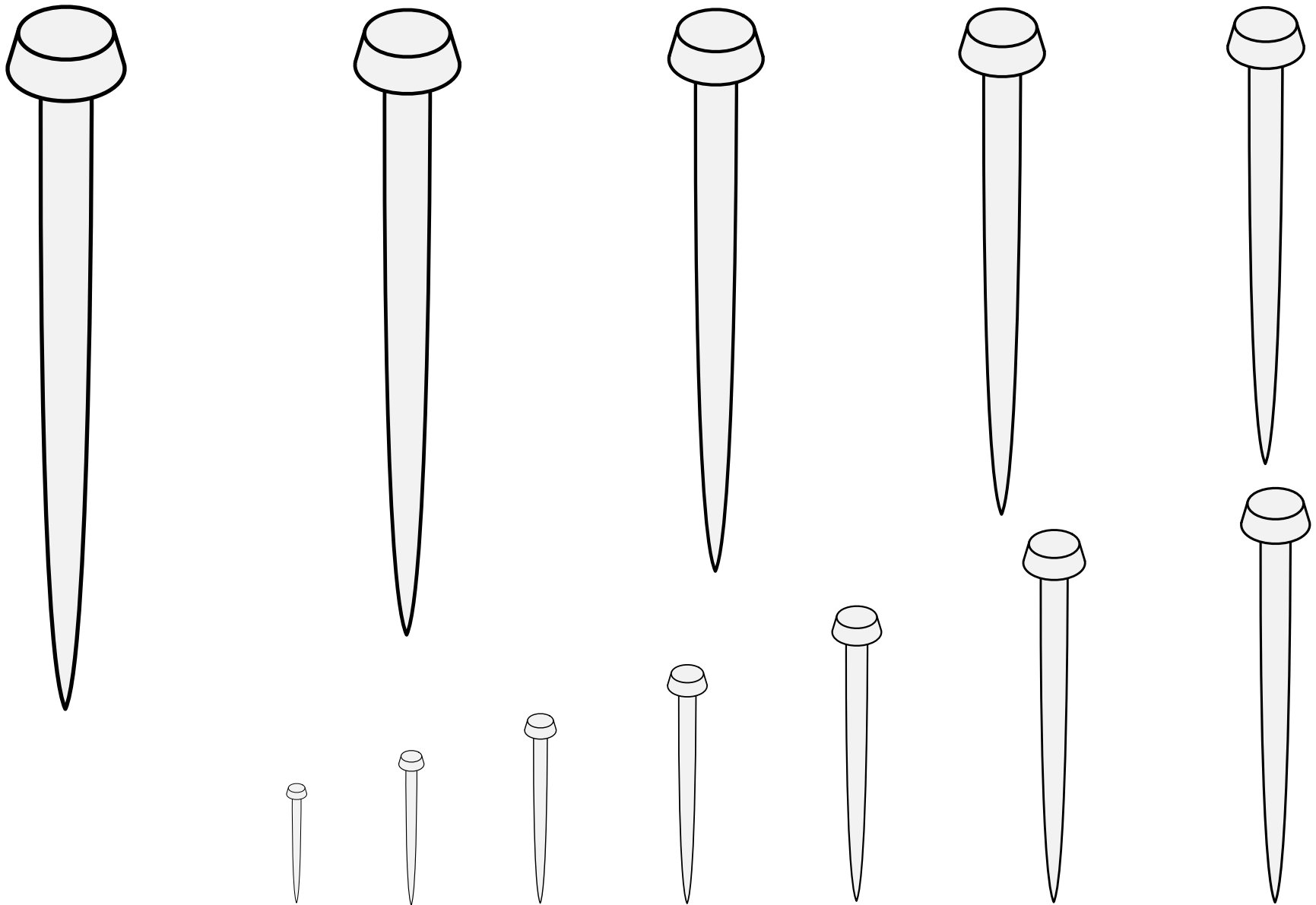

A glaziers nail.

Default alignment: palewise, point to base. No proper coloration.

Source: Zrdcadlo Slavného Margrabstwii Morawského. Artist unknown.

Nail, Closing (4) 16.89

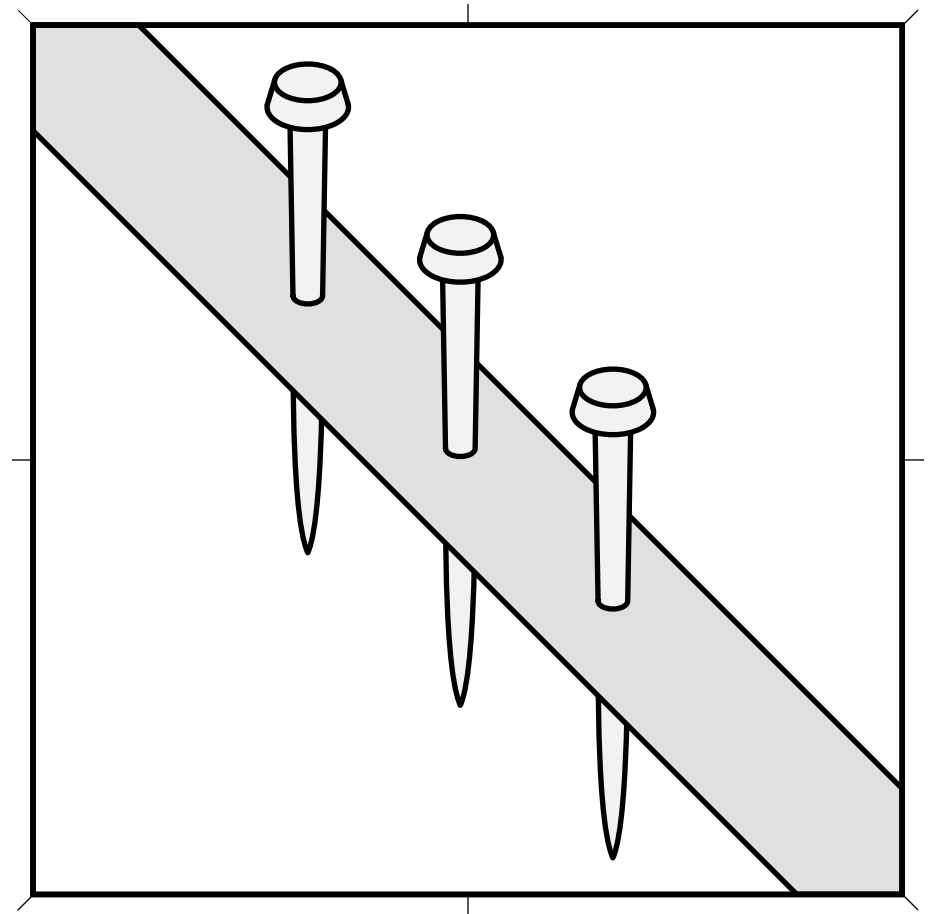
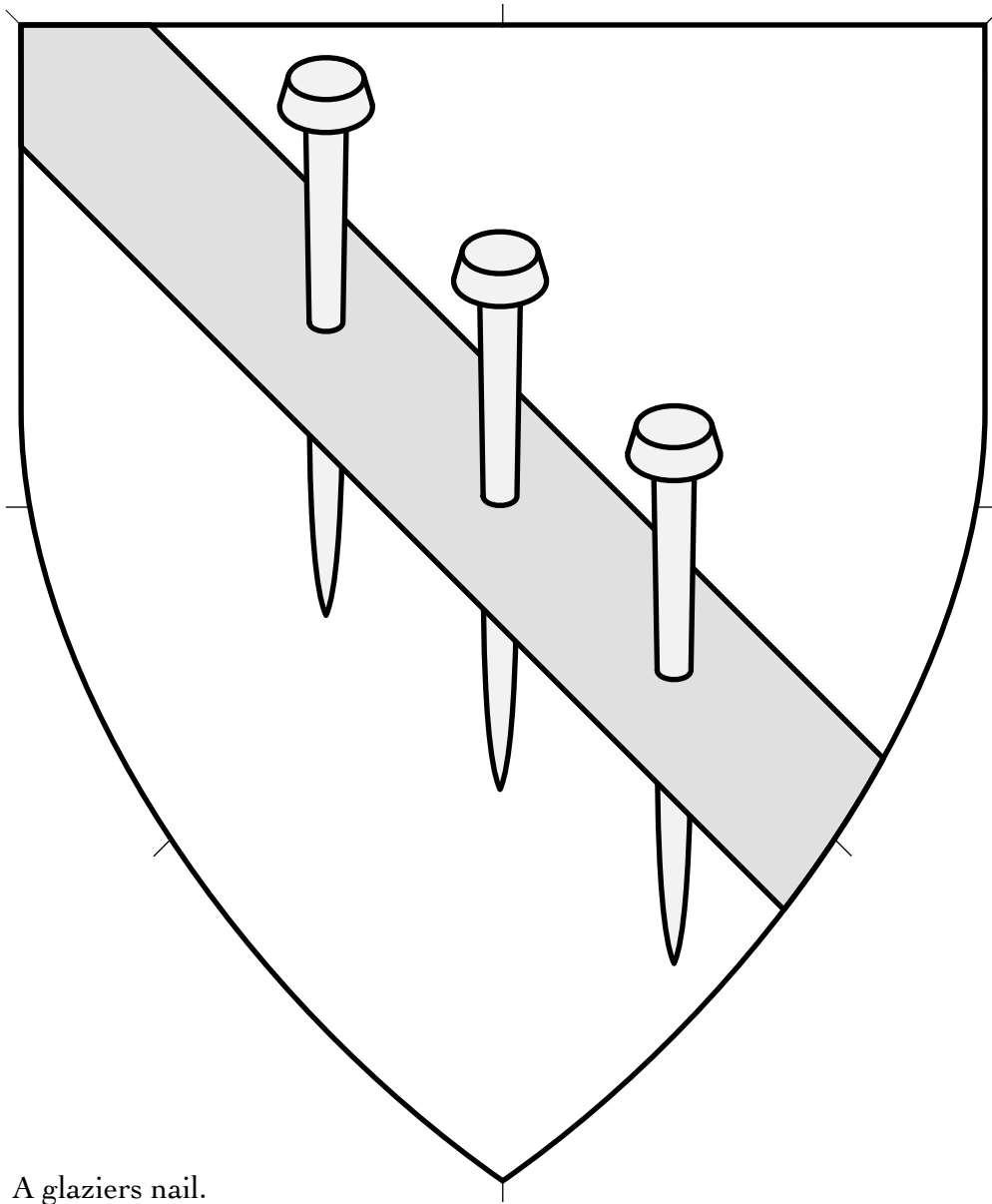

A glaziers nail.

Default alignment: palewise, point to base. No proper coloration.

Source: Zrdcadlo Slavného Margrabstwii Morawského. Artist unknown.

Nails, Bend Transfixed by Three Closing 16.90

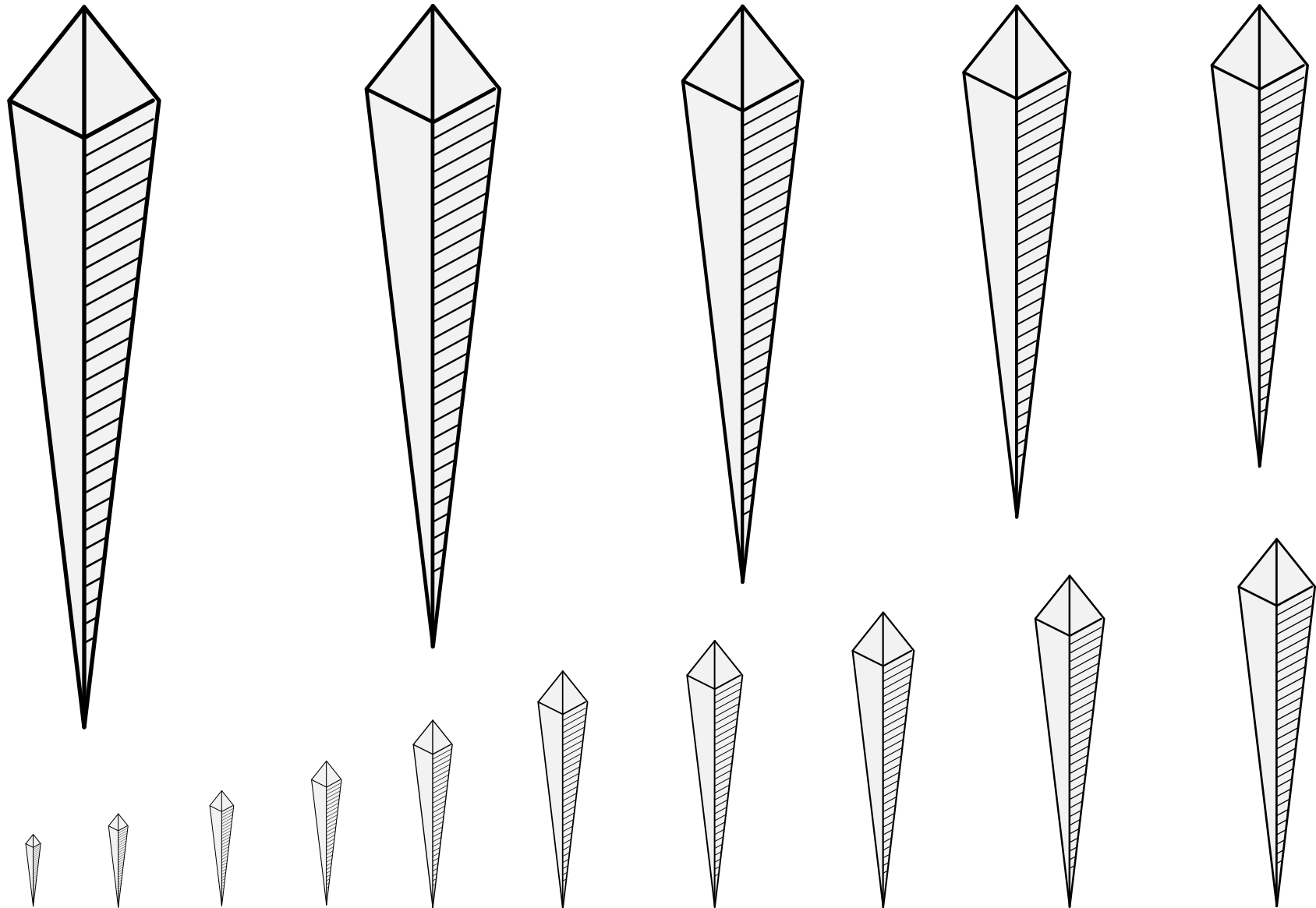

A carpenter's nail, called a passion nail due to its association with the crucifixion.
Default orientation: palewise, point to base.

Nail, Passion (1) 16.91

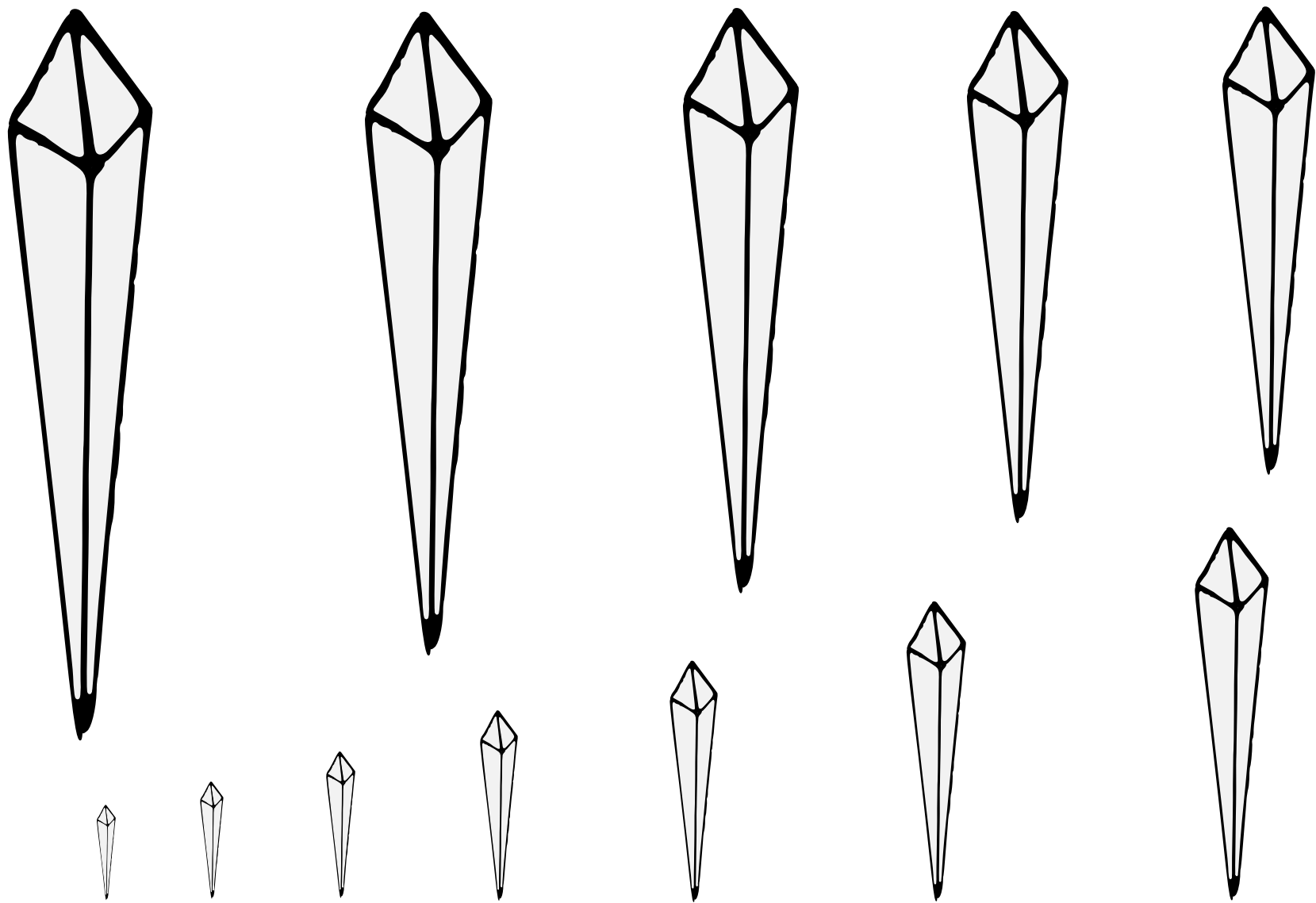

A carpenter's nail, called a passion nail due to its association with the crucifixion.

Default orientation: palewise, point to base.

Source: Pennsic Traceable Art. Artist: Roana d'Evreux.

Nail, Passion (2) 16.92

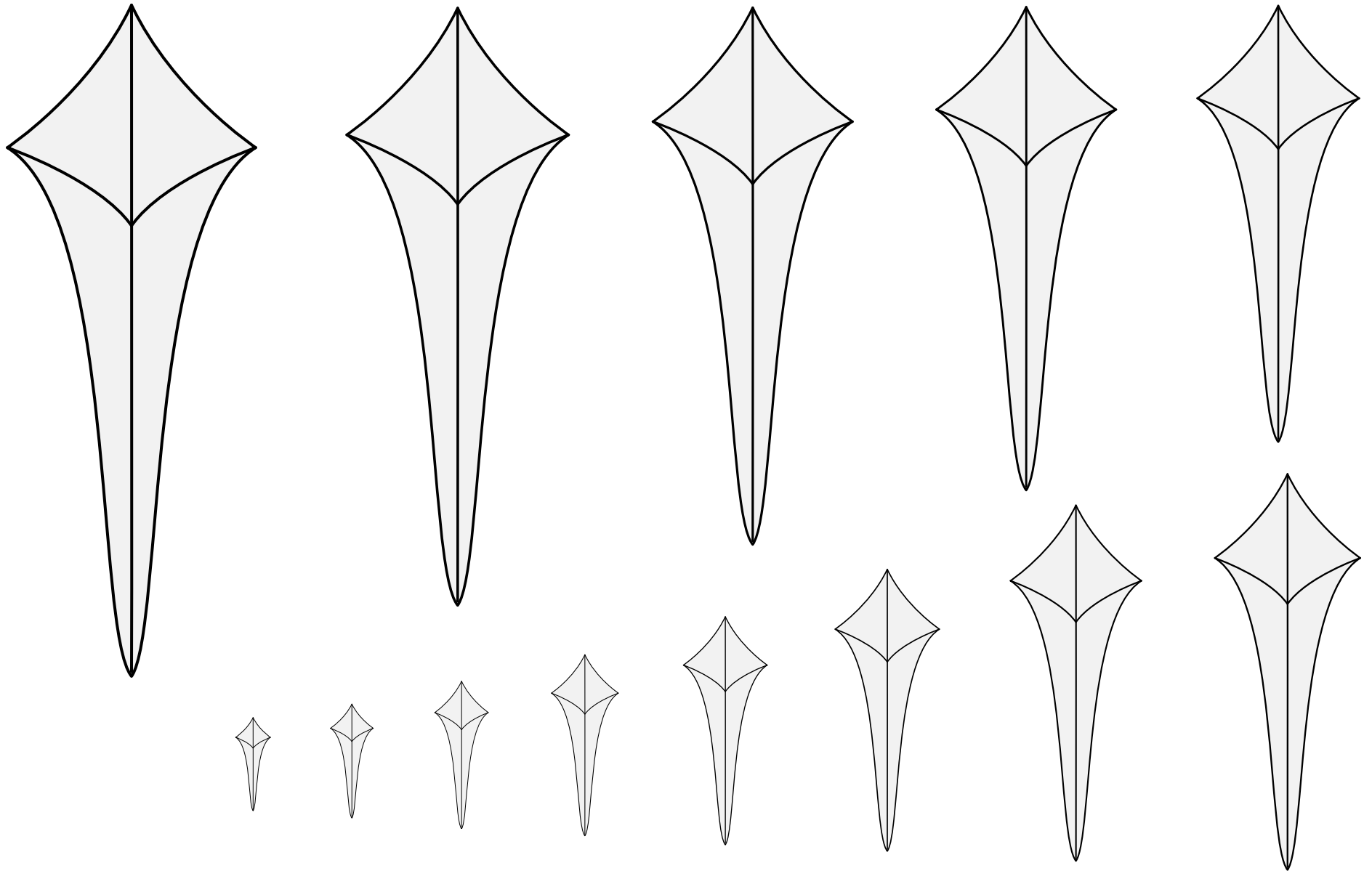

A carpenter's nail, called a passion nail due to its association with the crucifixion.

Default orientation: palewise, point to base.

Source: Les Blasons des Communautés d'Apothicaire au XVIIe Siècle.

Artist unknown.

Nail, Passion (3) 16.93

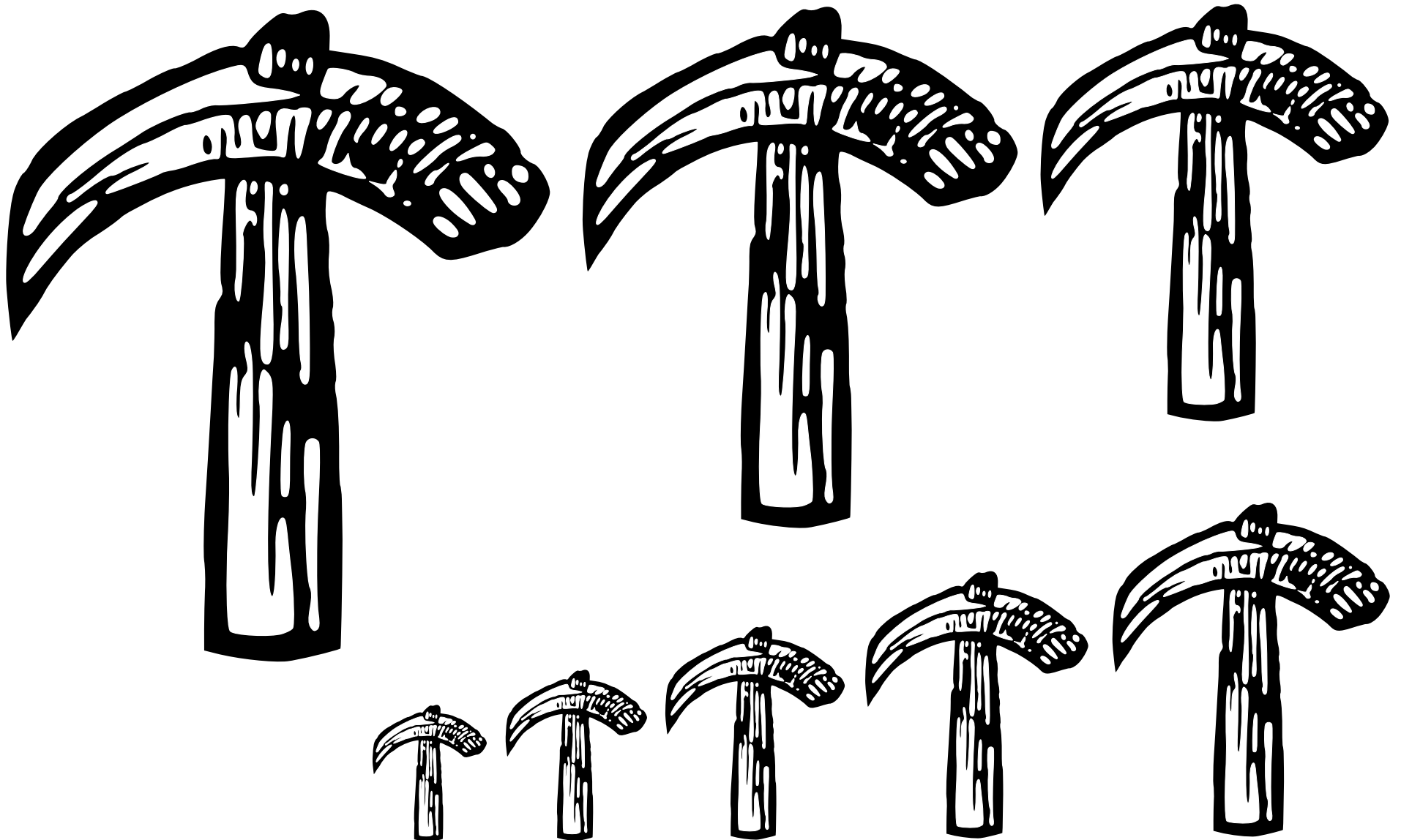

A digging tool used to break rocks or hard terrain.

Default orientation: fesswise, pointing to dexter. No proper coloration.

Source: Guillim's Display of Heraldry. Artist unknown.

Pick (1) 16.94

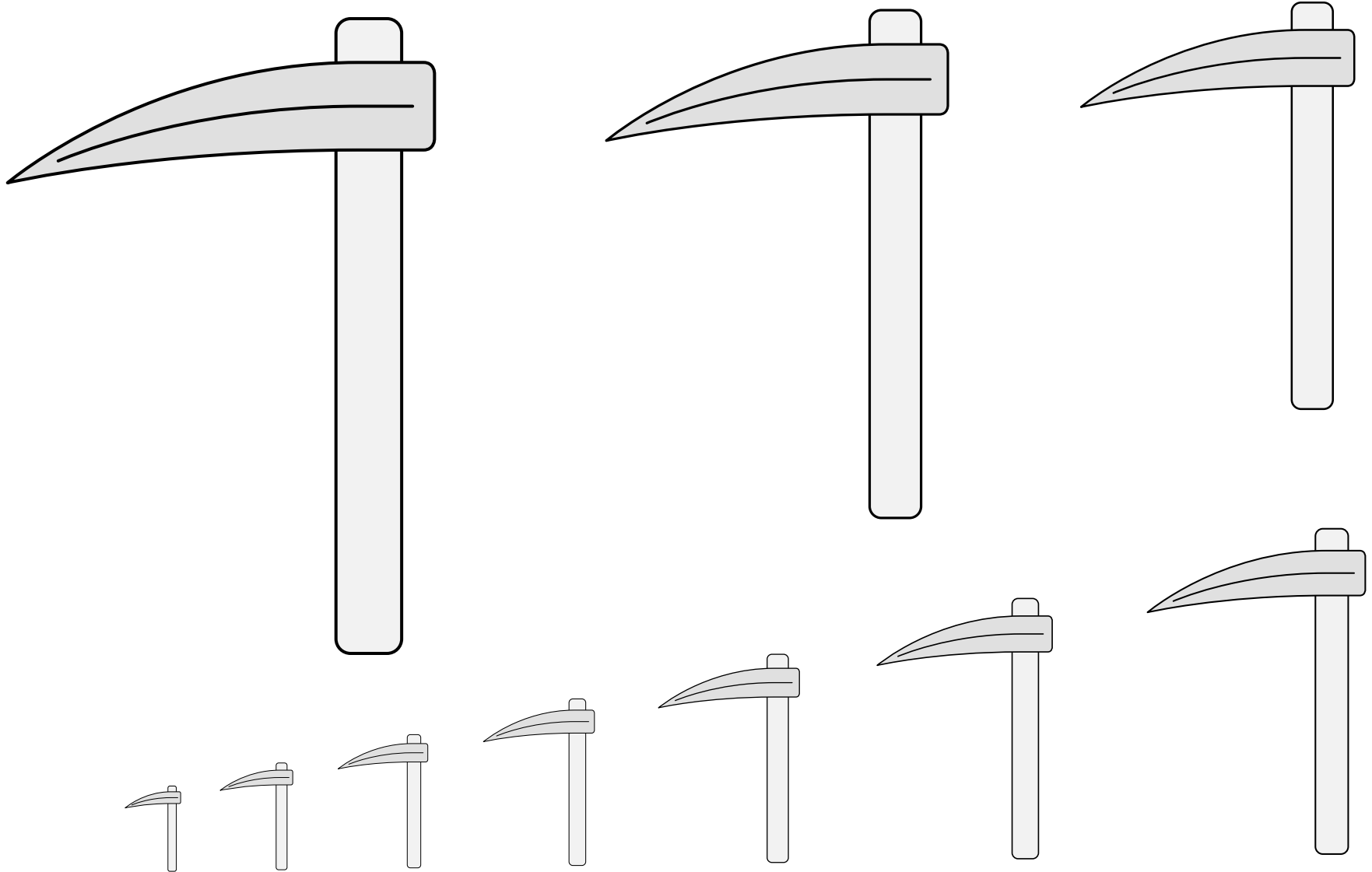

A digging tool used to break rocks or hard terrain.

Default orientation: fesswise, pointing to dexter. No proper coloration.

Source: Stemmario Trivulziano. Artist: Gian Antonio da Tradate.
(Arms of di Ponzo, folio 283r.) Adapted by Mathghamhain Ua Ruadháin.

Pick (2) 16.95

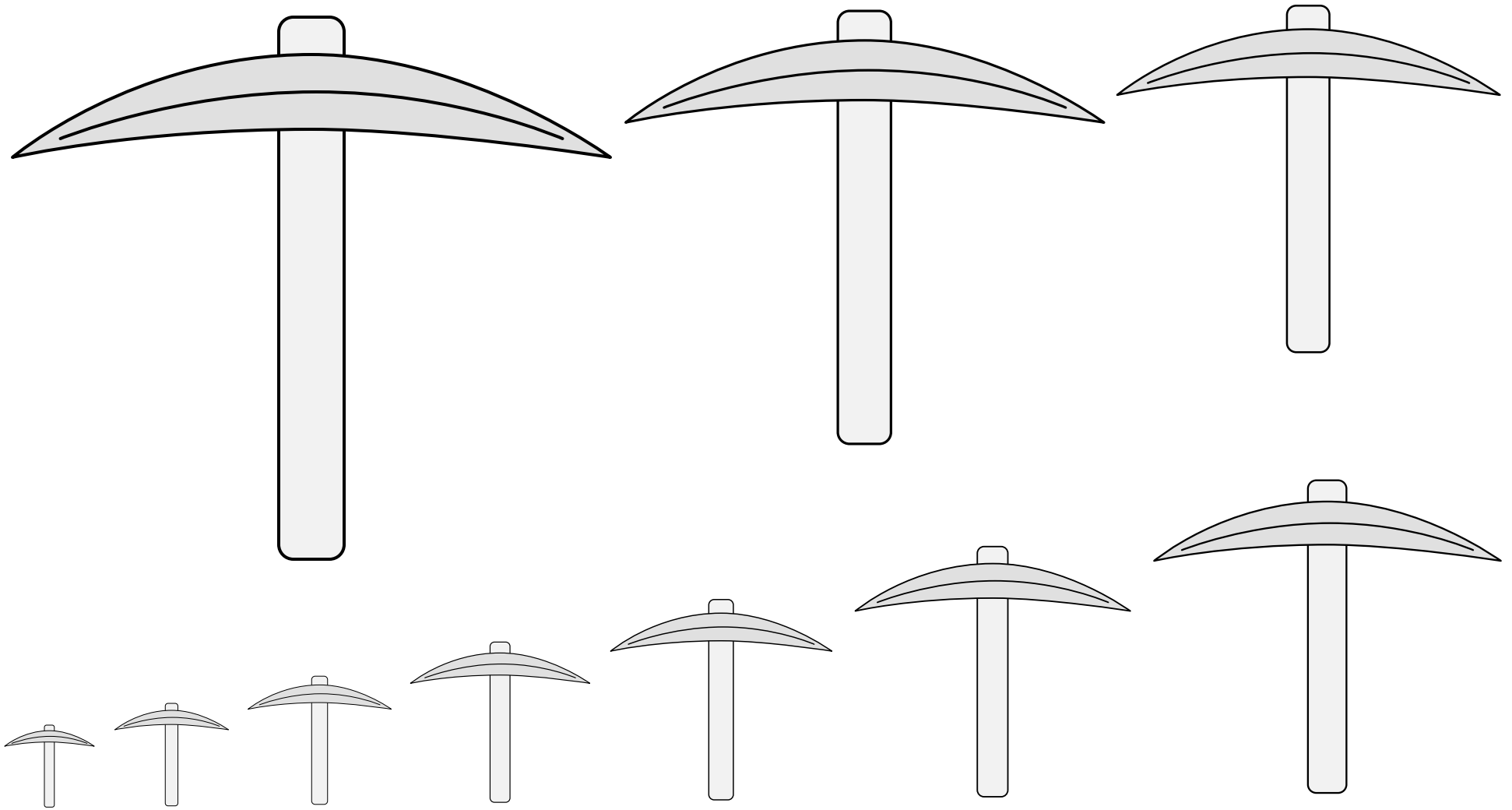

A digging tool used to break rocks or hard terrain.

Default orientation: fesswise, pointing to dexter. No proper coloration.

Source: Stemmario Trivulziano. Artist: Gian Antonio da Tradate.
(Arms of di Ponzo, folio 283r.) Adapted by Mathghamhain Ua Ruadháin.

Pick (3) 16.96

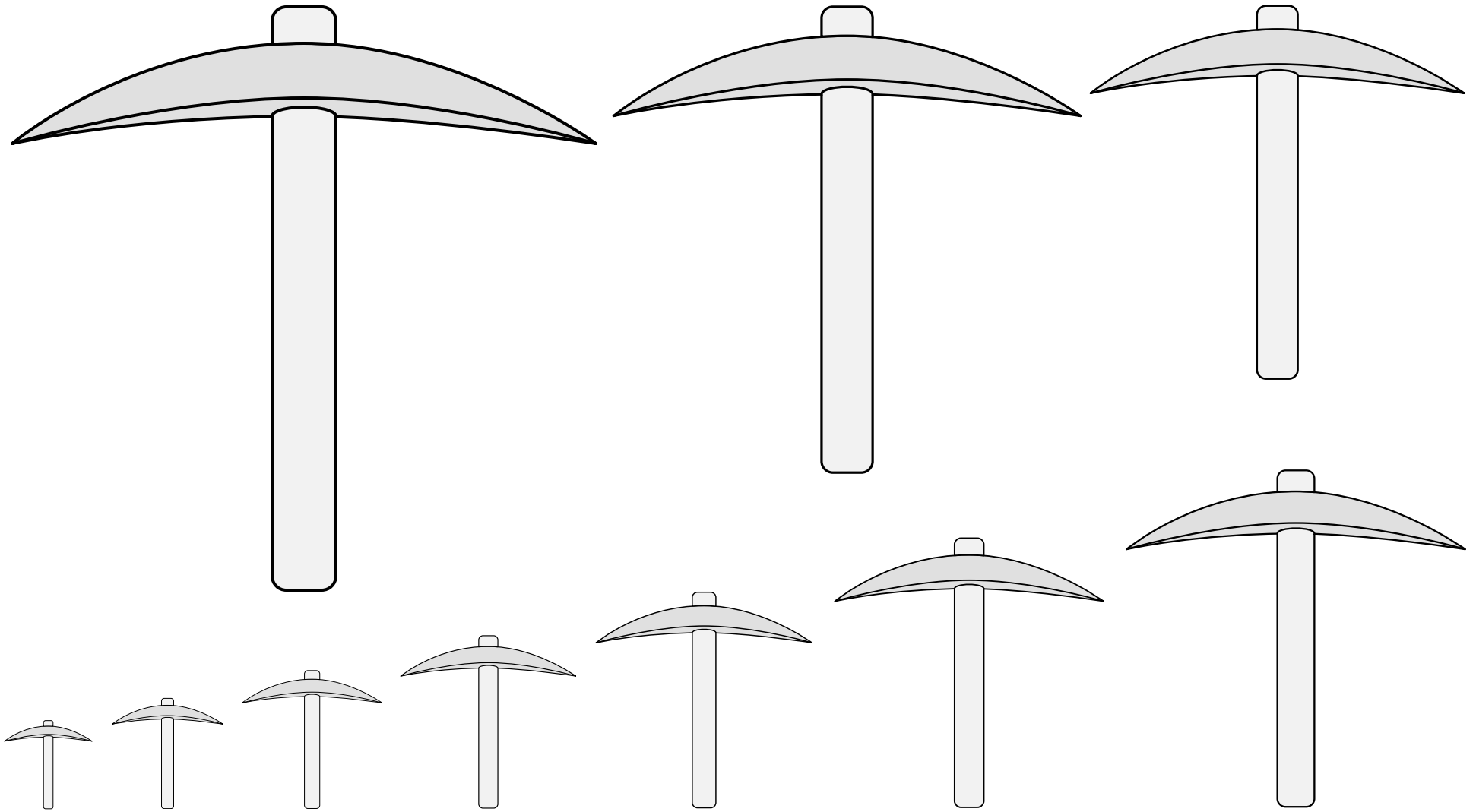

A digging tool used to break rocks or hard terrain.

Default orientation: fesswise, pointing to dexter. No proper coloration.

Source: Stemmario Trivulziano. Artist: Gian Antonio da Tradate.
(Arms of di Ponzo, folio 283r.) Adapted by Mathghamhain Ua Ruadháin.

Pick (4) 16.97

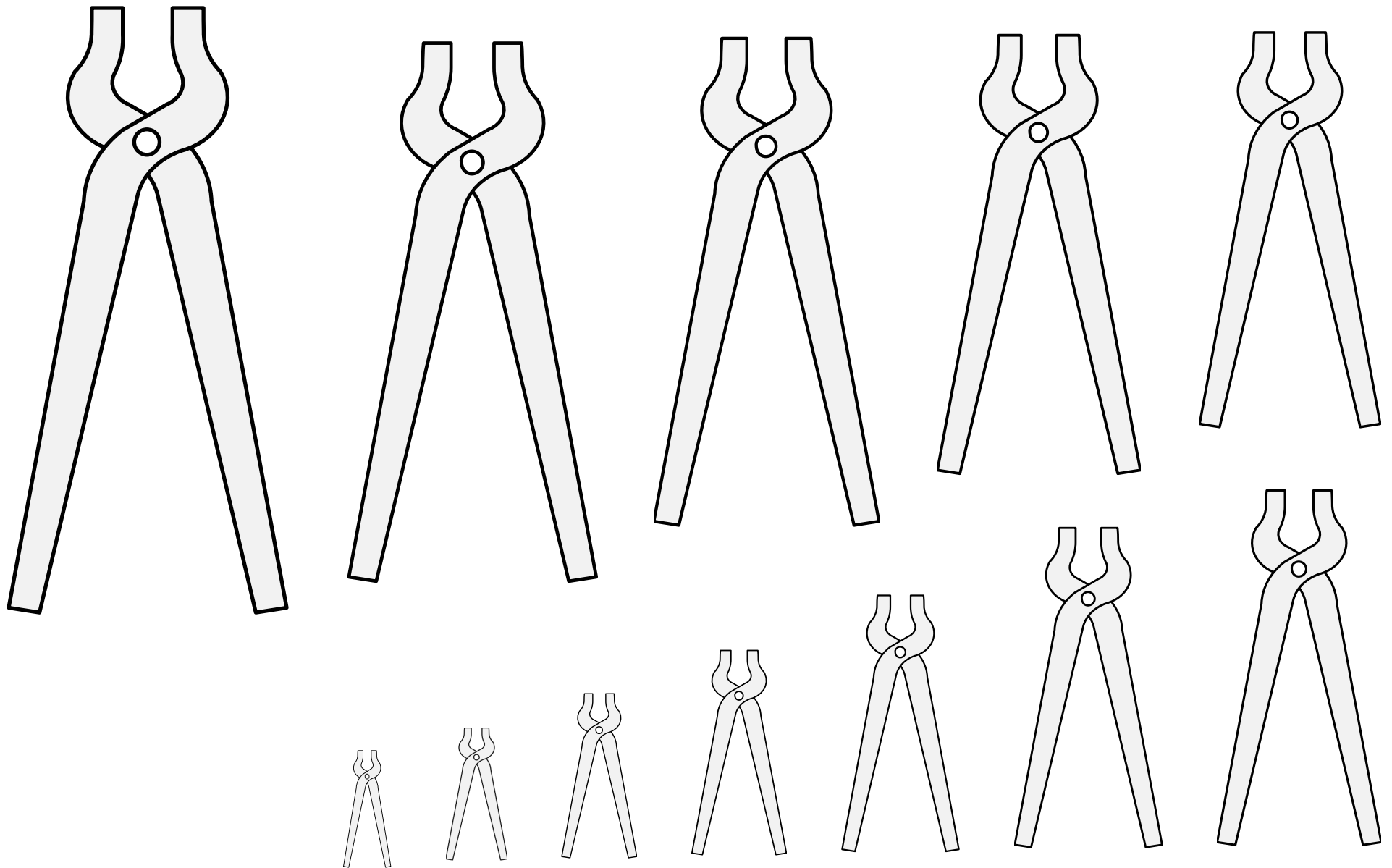

A gripping tool.

Default orientation: handles to base. No proper coloration.

Source: Viking Answer Lady SVG Images For Heralds.

Artist: Gunnvôr silfrahárr.

Pliers, Pair Of (1) 16.98

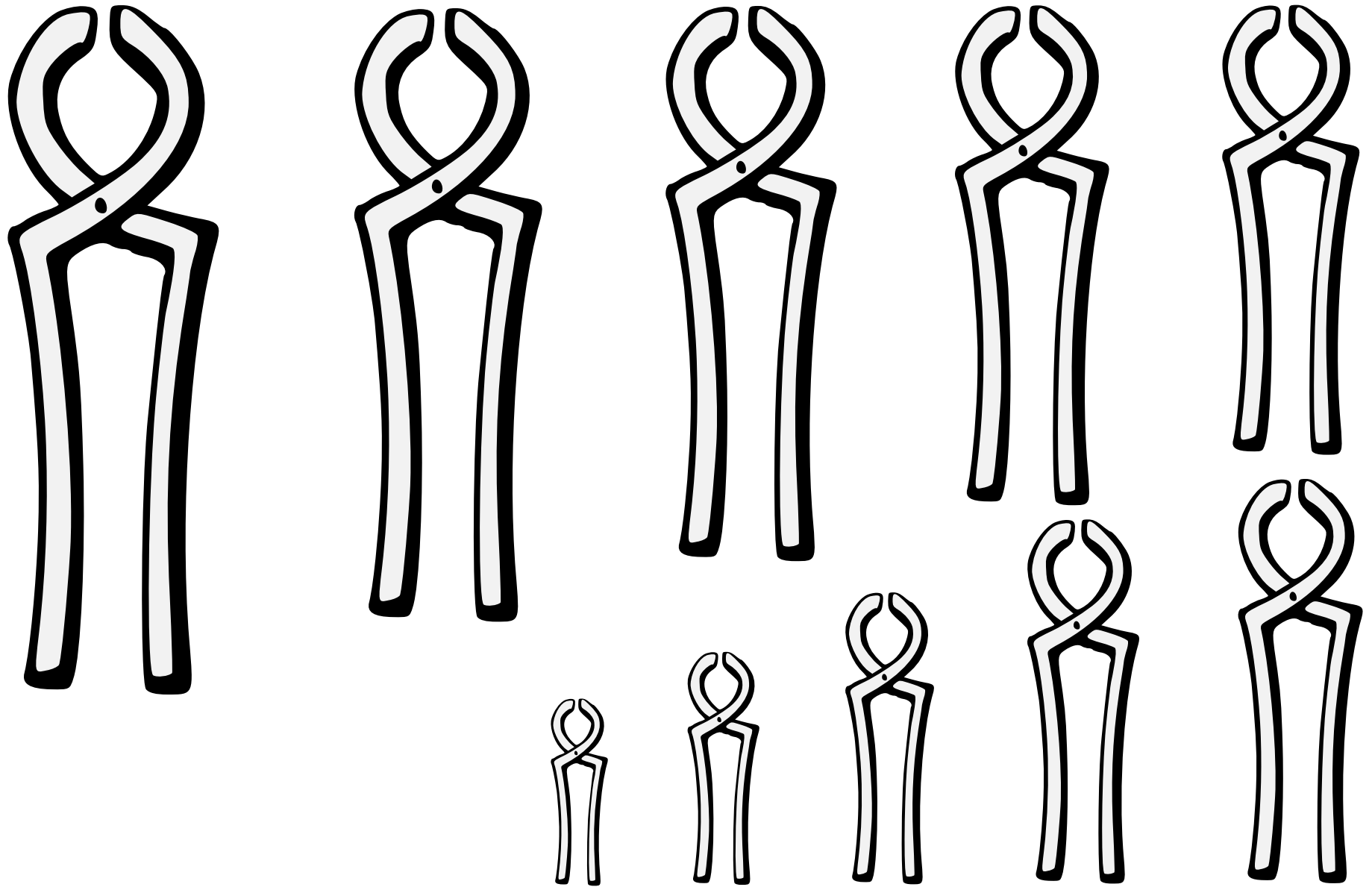

A gripping tool.

Default orientation: handles to base. No proper coloration.

Source: A Glossary of Terms Used in Heraldry. Artist: James or Irene Parker.

Pliers, Pair Of (2) 16.99

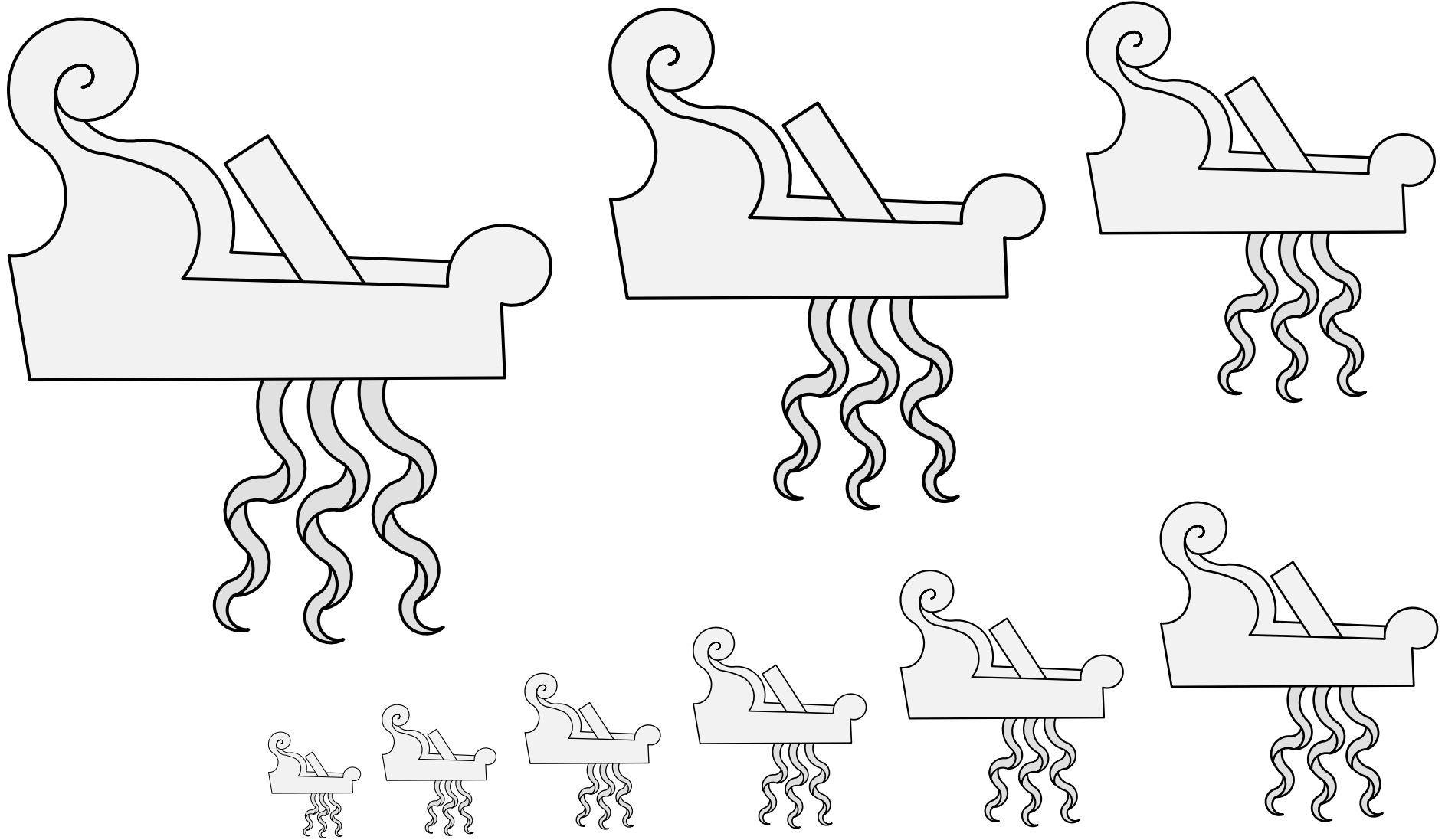

A sharp-bladed woodworking tool.

Default orientation: fesswise, cutting to sinister. No proper coloration.

Source: Viking Answer Lady SVG Images For Heraldists.

Artist: Gunnvôr silfrhárr.

Plane, Block (1) 16.100

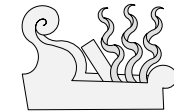
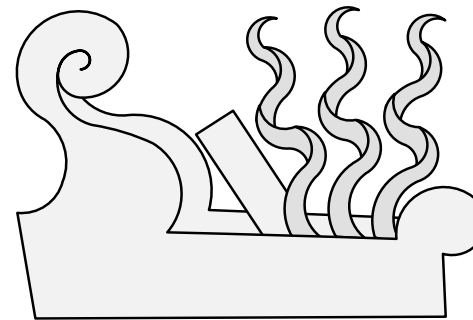
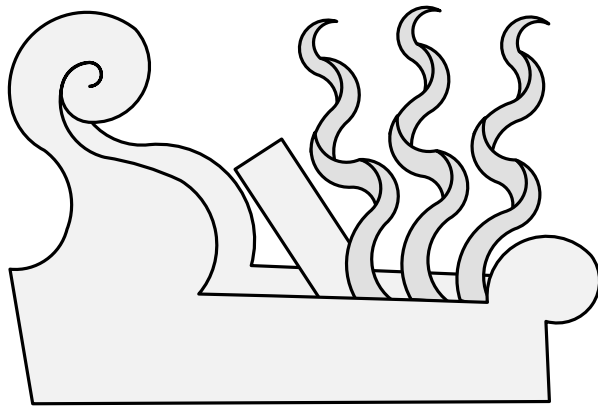
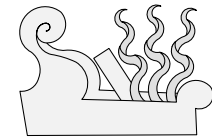
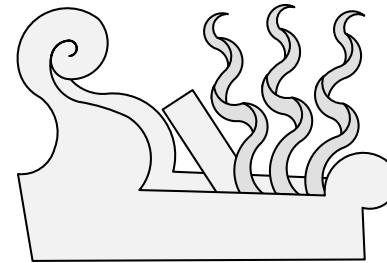
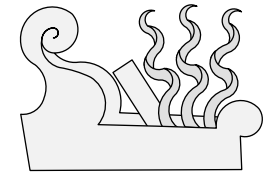
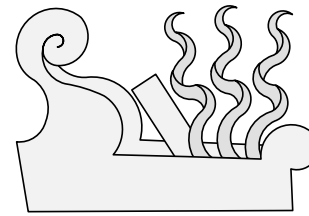
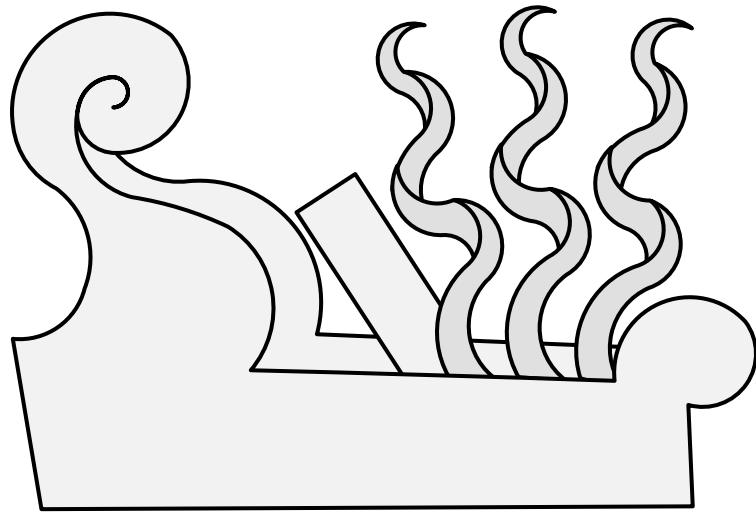

A sharp-bladed woodworking tool.

Default orientation: fesswise, cutting to sinister. No proper coloration.

Source: Viking Answer Lady SVG Images For Heraldry.

Artist: Gunnvôr silfrhárr. Adapted by Mathghamhain Ua Ruadháin.

Plane, Block (2) 16.101



A sharp-bladed woodworking tool.

Default orientation: fesswise, cutting to sinister. No proper coloration.

Source: Devises Heroiques et Emblemes. Artist unknown.
(Page 197, badge of Duc Jean de Bourgogne.)

Plane, Block (3) 16.102



A lead weight, to be attached to a cord for use as a plumb line or sounding line.

Default orientation: hanging loop to chief. No proper coloration.

Source: Guillim's Display of Heraldry. Artist unknown.

Plummet 16.103

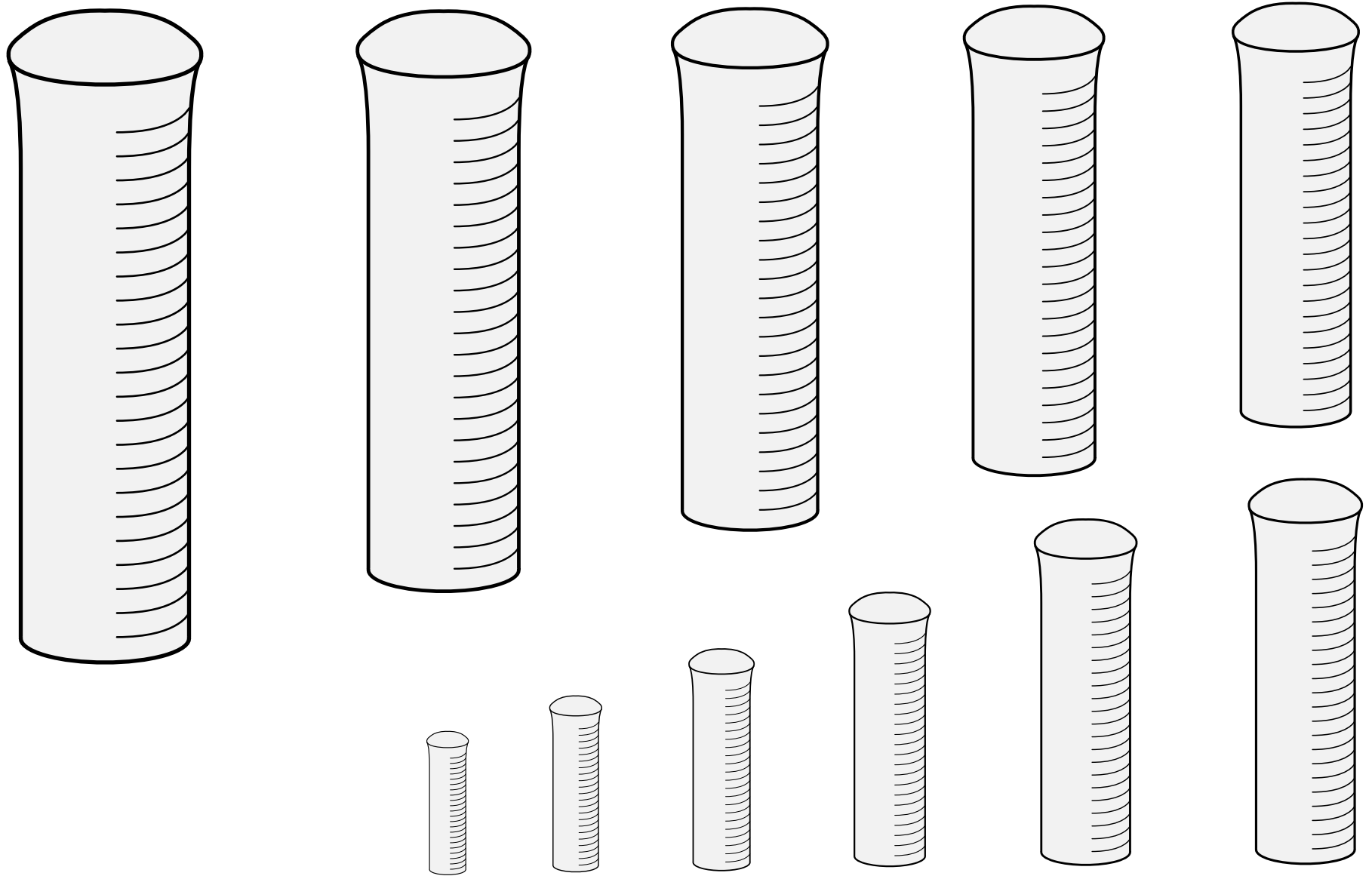

A tool used for minting coins.

Default orientation: head to chief. No proper coloration.

Source: Das Ständebuch. (From plate "Der Munkmeister.") Artist: Jost Amman.

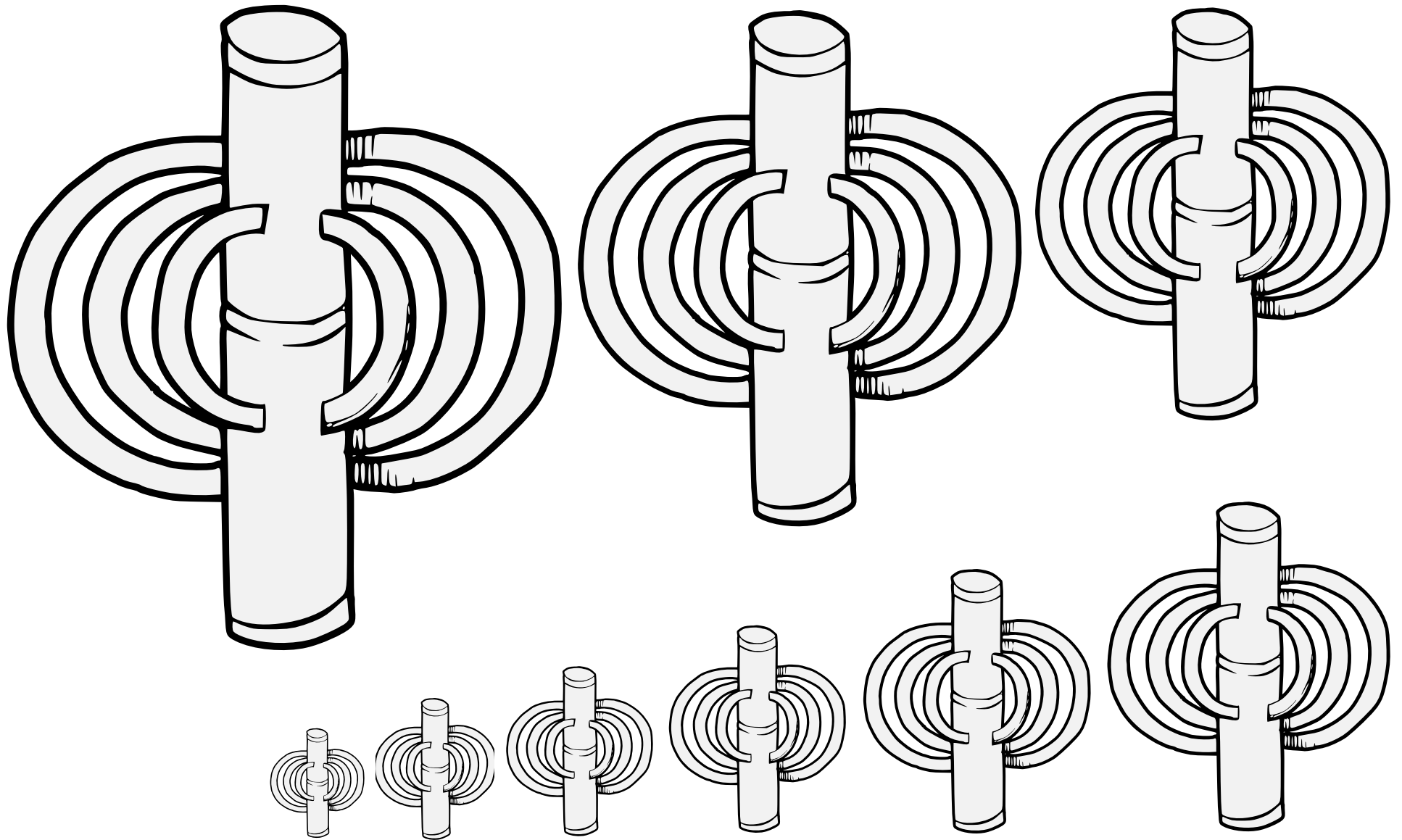

A tamping tool for flattening soil.

Default orientation: palewise. No proper coloration.

Source: Scheibler Armorial. Artist: Unknown. (From the arms of Aufheim.)

Punner (1) 16.105

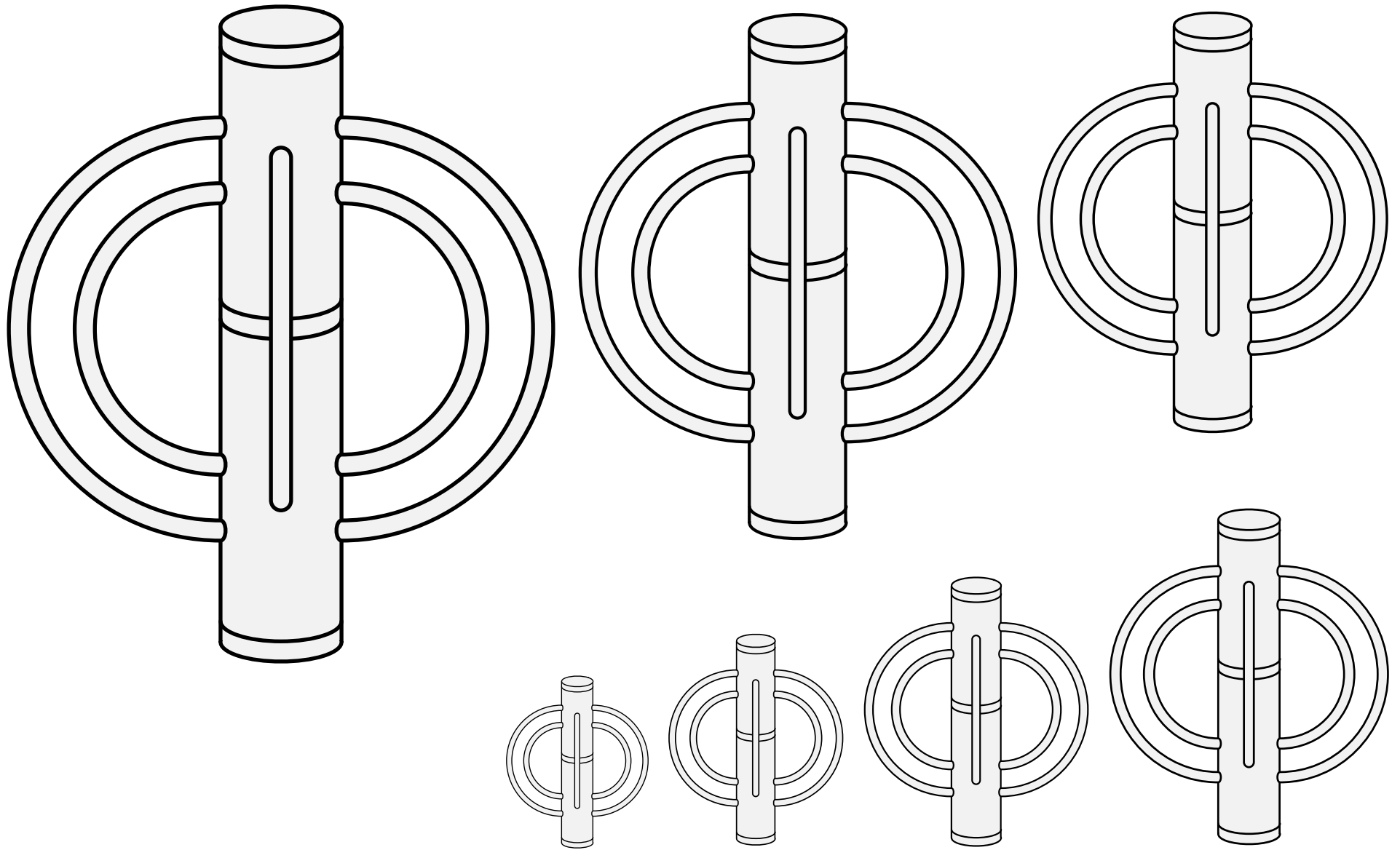

A tamping tool for flattening soil.
Default orientation: palewise. No proper coloration.

Punner (2) 16.106

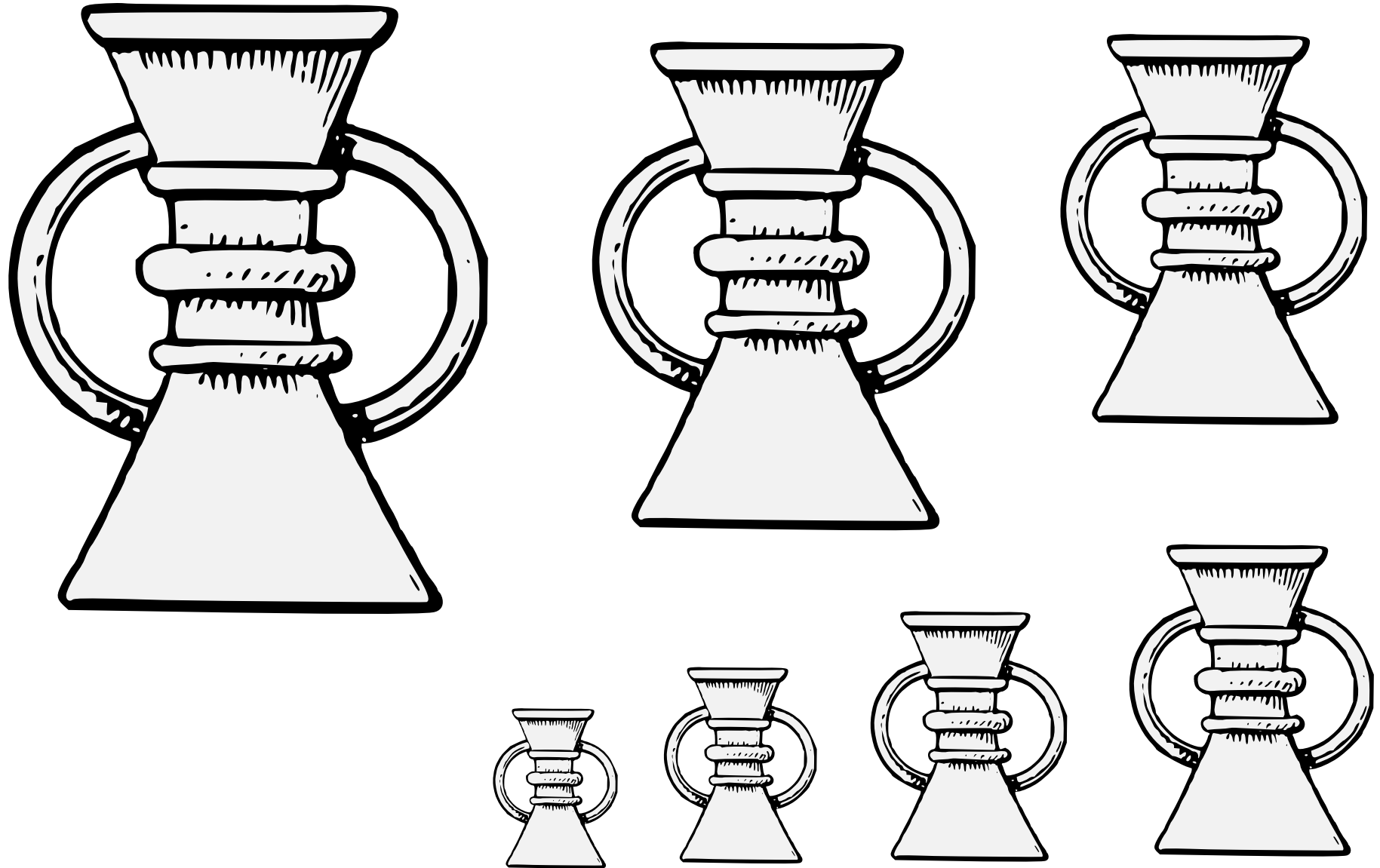

A tamping tool for flattening soil.

Default orientation: palewise. No proper coloration.

This is a post-period depiction, and is unregistrable without evidence of earlier use.

Source: Neuer Siebmacher. Artist unknown.

(From volume 5, section 9, arms of de Ramme, granted 1533, published 1912.)

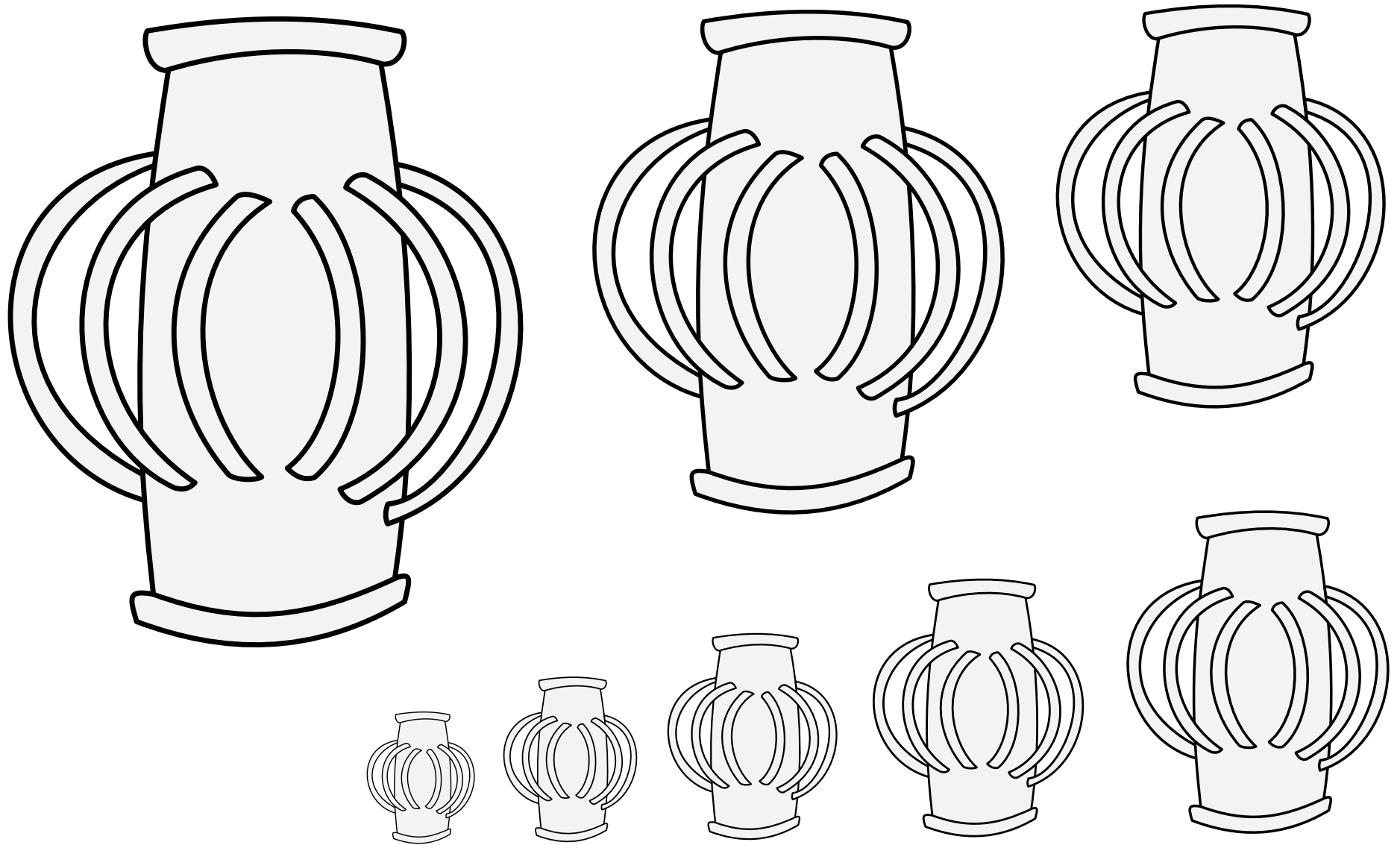

A tamping tool for flattening soil.

Default orientation: palewise. No proper coloration.

Source: Annales Carinthiae. Artist unknown. (Page 788.) Adapted by Iago ab Adam.

Punner (4) 16.108



A tamping tool for flattening soil.

Default orientation: palewise. No proper coloration.

Source: BnF MS Allemand 304. Artist unknown. (Page 713.)

Punner (5) 16.109



A tamping tool for flattening soil.

Default orientation: palewise. No proper coloration.

Source: BnF MS Allemand 304. Artist unknown. (Page 713.)

Punner (6) 16.110

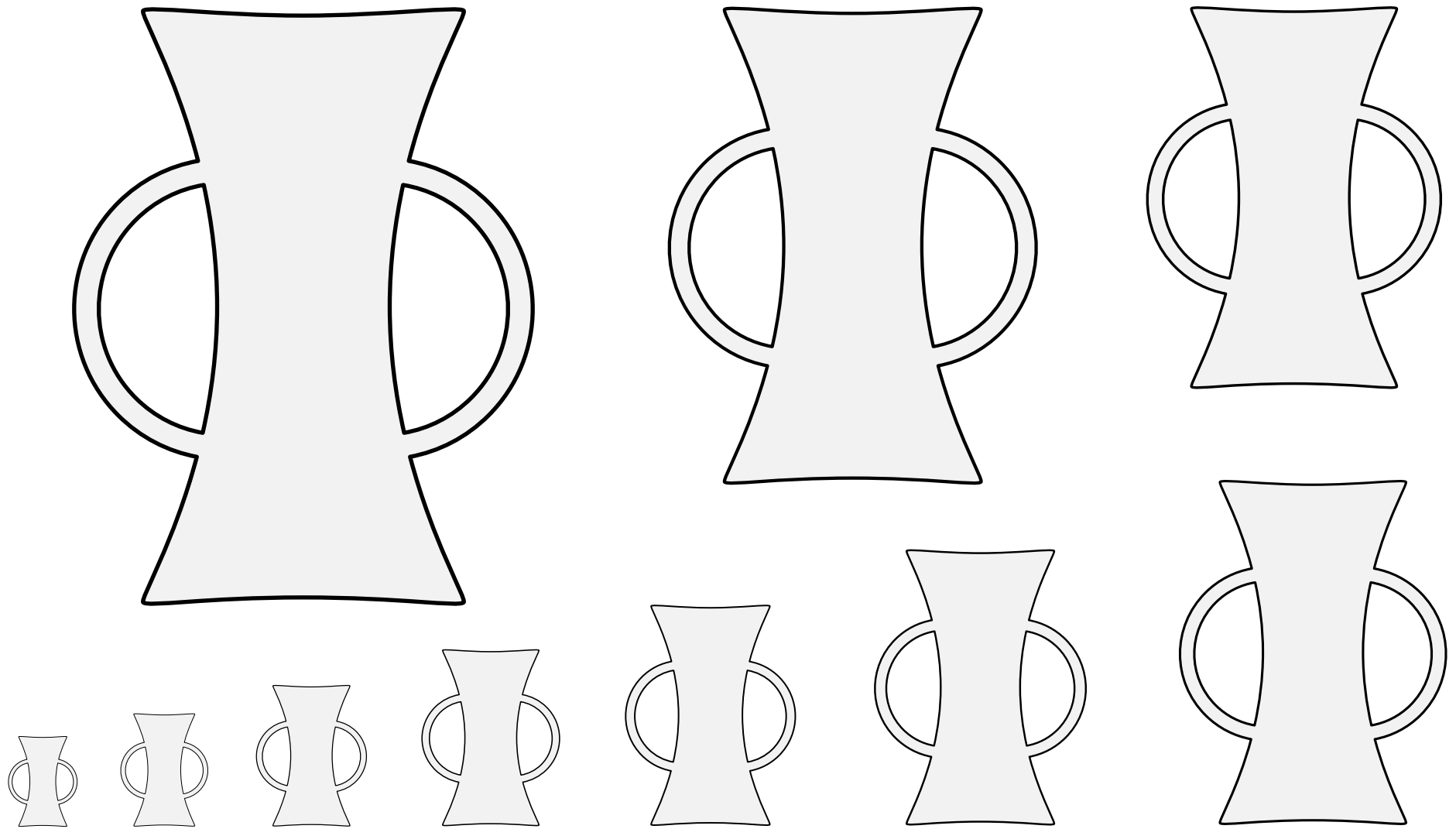

A tamping tool for flattening soil.

Default orientation: palewise. No proper coloration.

Source: Des Kaiserlichen Kammergerichts zu Speier Kammerrichter.
Artist unknown. (Page 46.)

Punner (7) 16.111

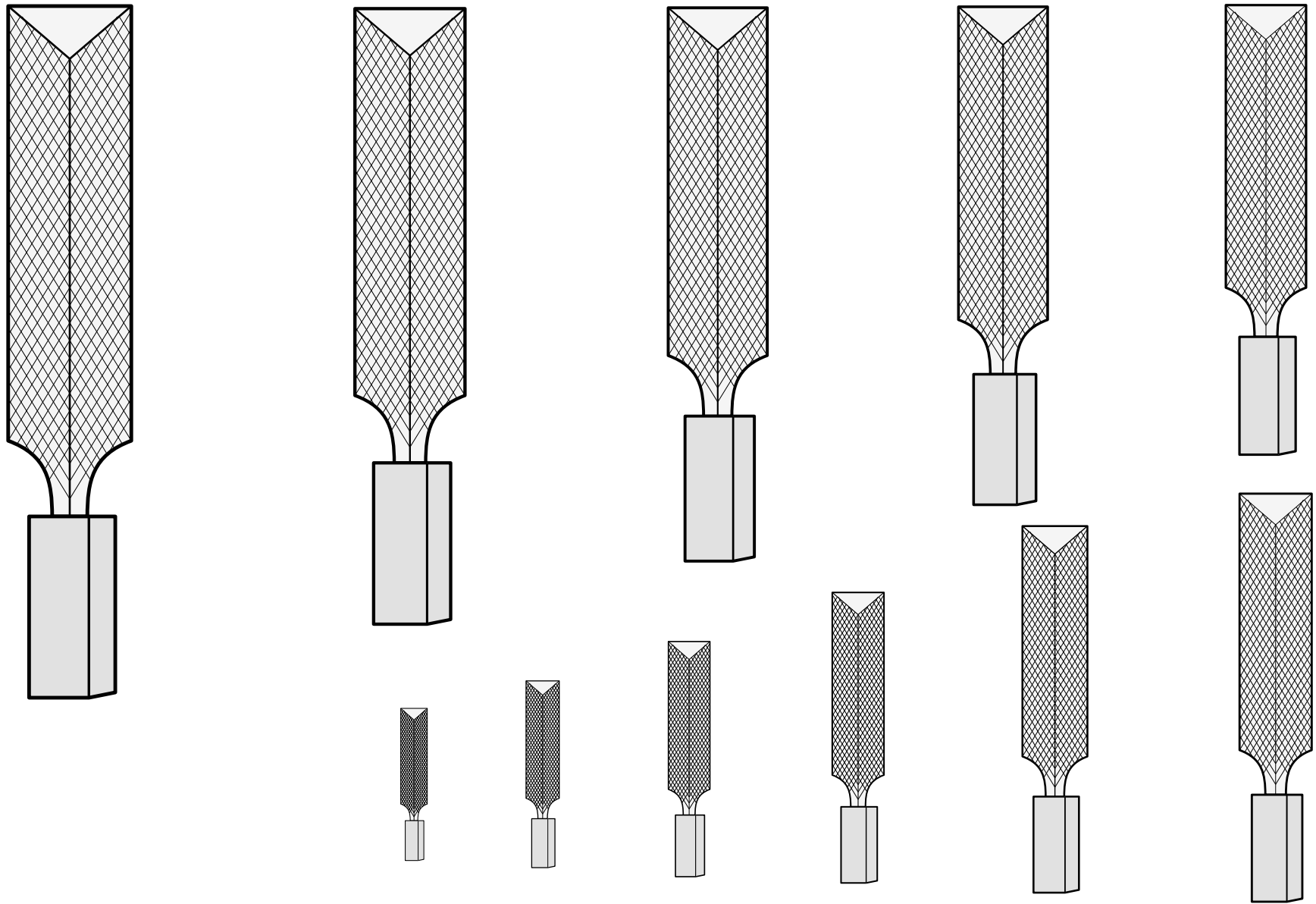

A hard metal tool covered in sharp grooves whose rough surface is used to smooth out items in a workshop.

Default orientation: handle to base. No proper coloration..

Source: A Display of Heraldry. Artist: John Guillim.
(Manuscript folio 105r.) Adapted by Iago ab Adam.

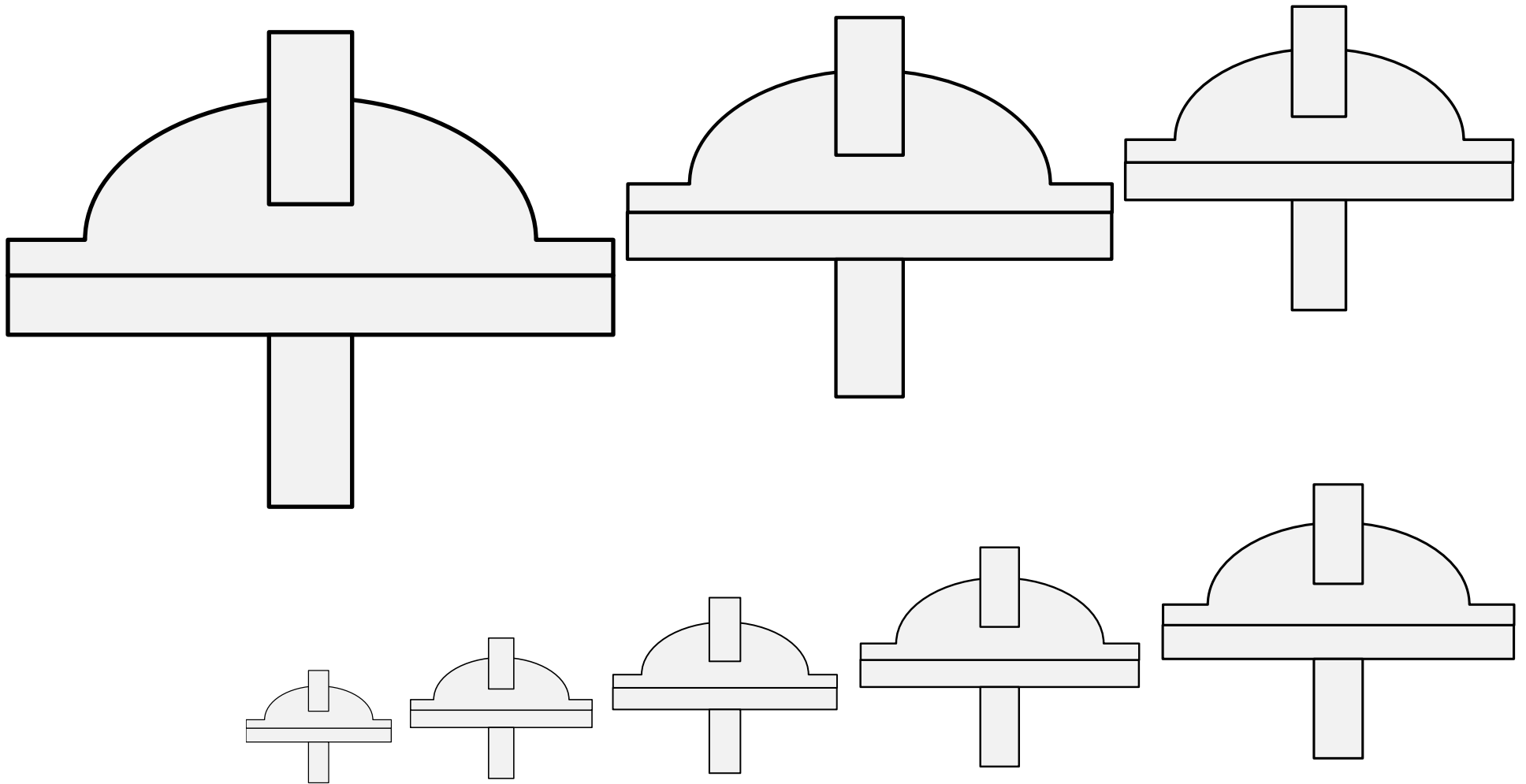

A specialized form of plane used for cutting grooves in barrels, also known as a croze.

Default orientation: bar palewise, curve to chief. No proper coloration.

Adapted from images of the arms of the Worshipful Company of Coopers. (Granted 1509.)

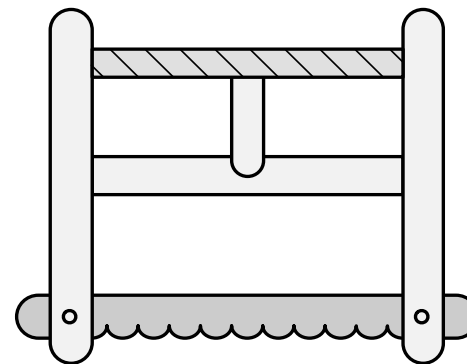
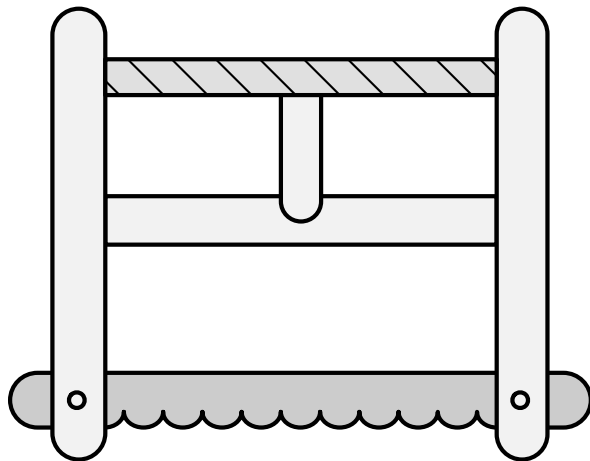
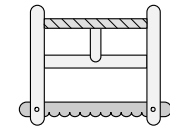
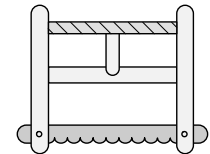
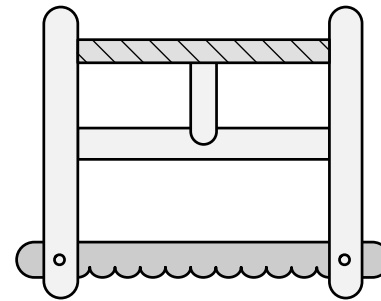
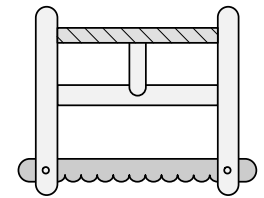
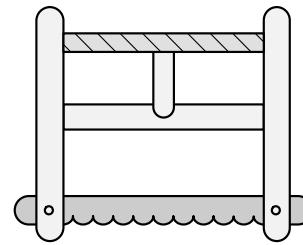
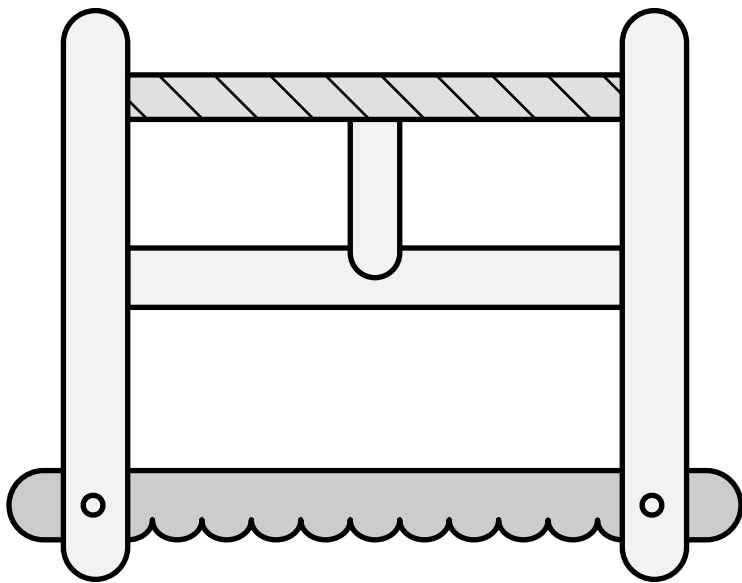

A cutting tool for wood with an indented-edged blade.

Default orientation: fesswise, blade to base. No proper coloration.

Source: Libro de Armas y Blasones de Diversos Linajes y Retratos. Artist unknown. (Folio 91r.)

Saw, Frame 16.114

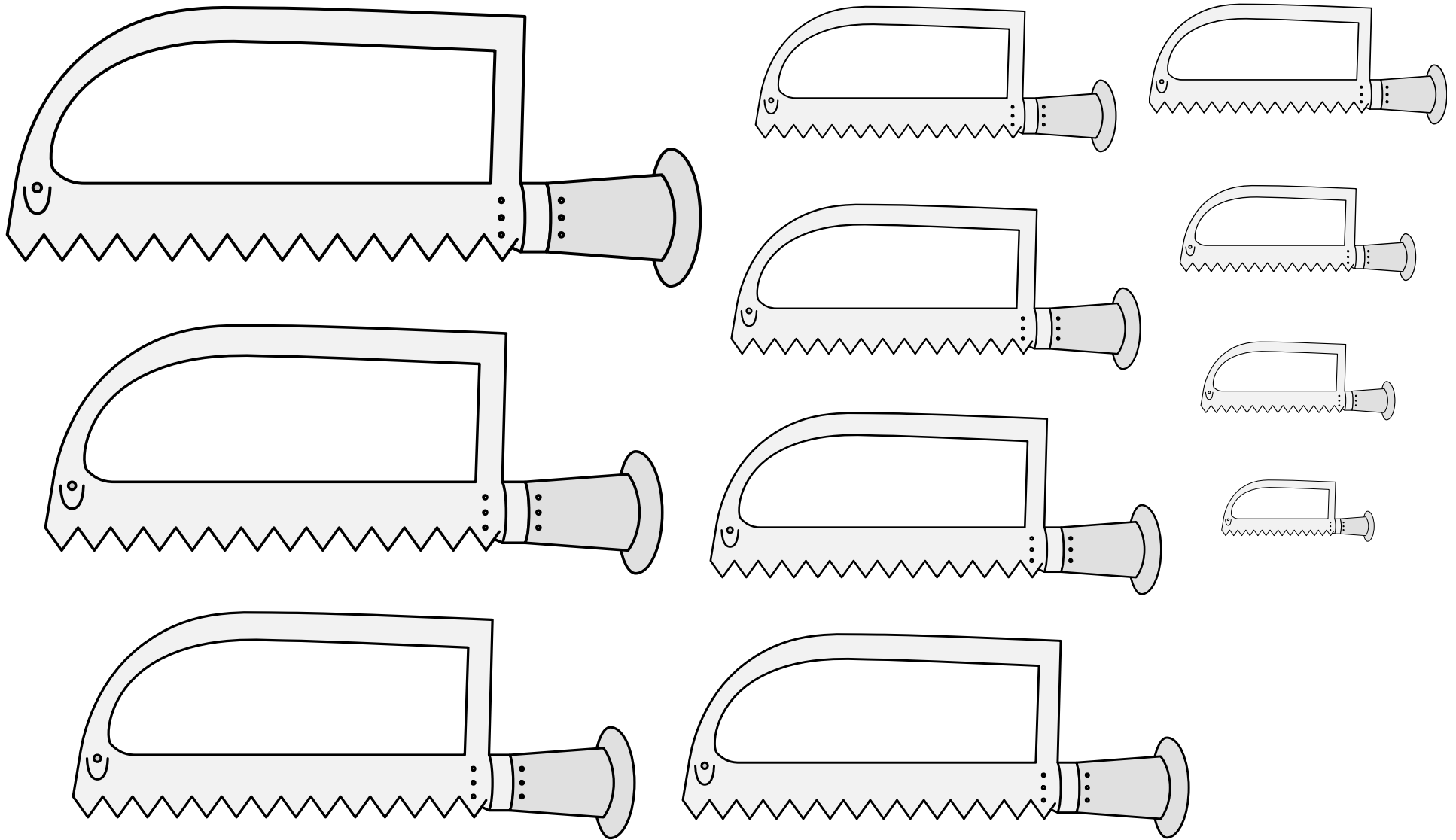

A cutting tool for wood with an indented-edged blade.

No default orientation; when fesswise, blade to base and handle to sinister. No proper coloration.

Source: Wappenbuch der Arlberg-Bruderschaft.
Artist: Vigil Raber. (Page 258.)

Saw, Goldsmith's Frame- 16.115

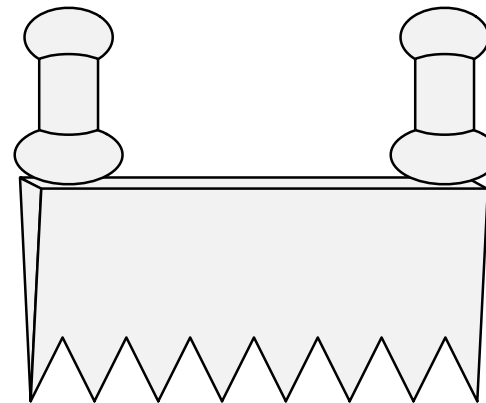
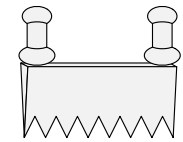
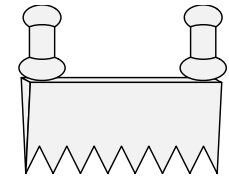
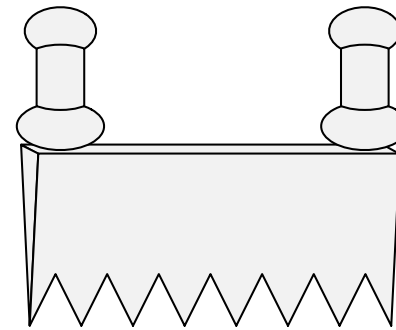
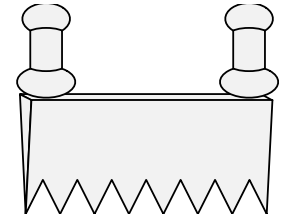
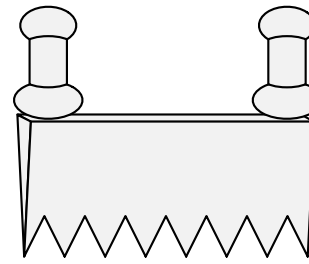
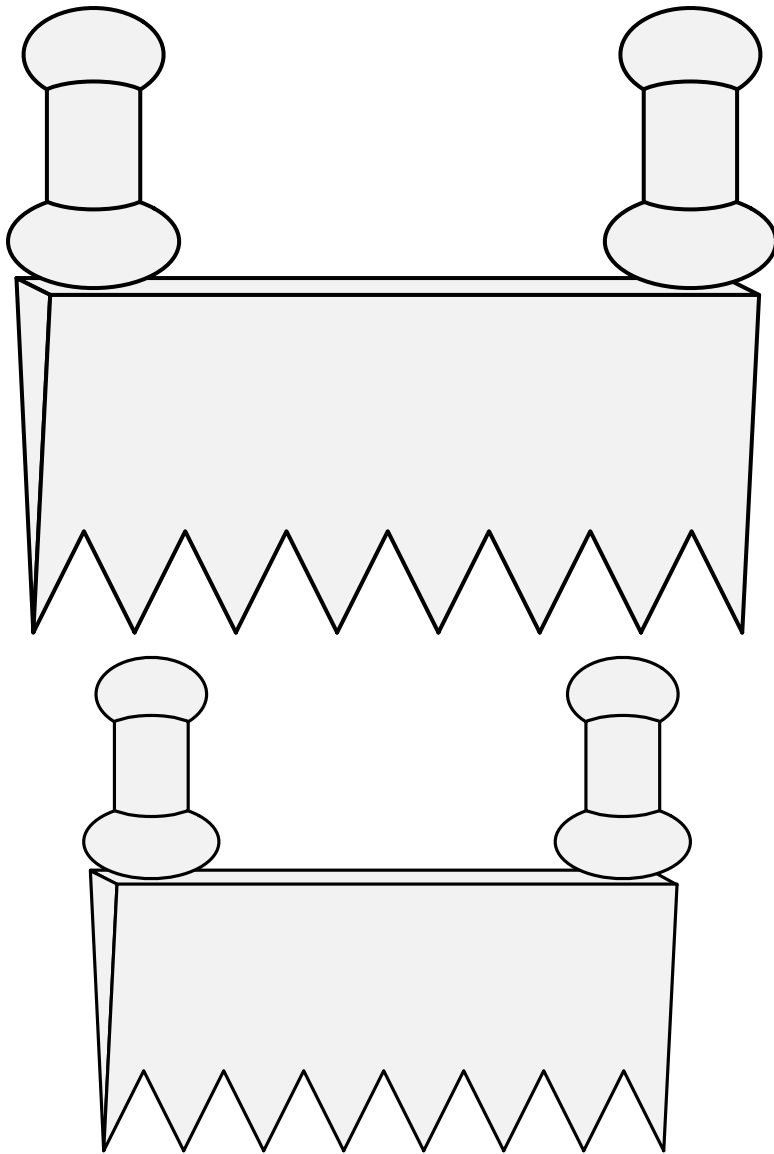

A cutting tool for wood with an indented-edged blade.

Default orientation: fesswise, blade to base. No proper coloration.

Source: Wappenbuch Conrads von Grünenberg.

Artist unknown.

Saw, Two-Man Cross-Cut 16.116

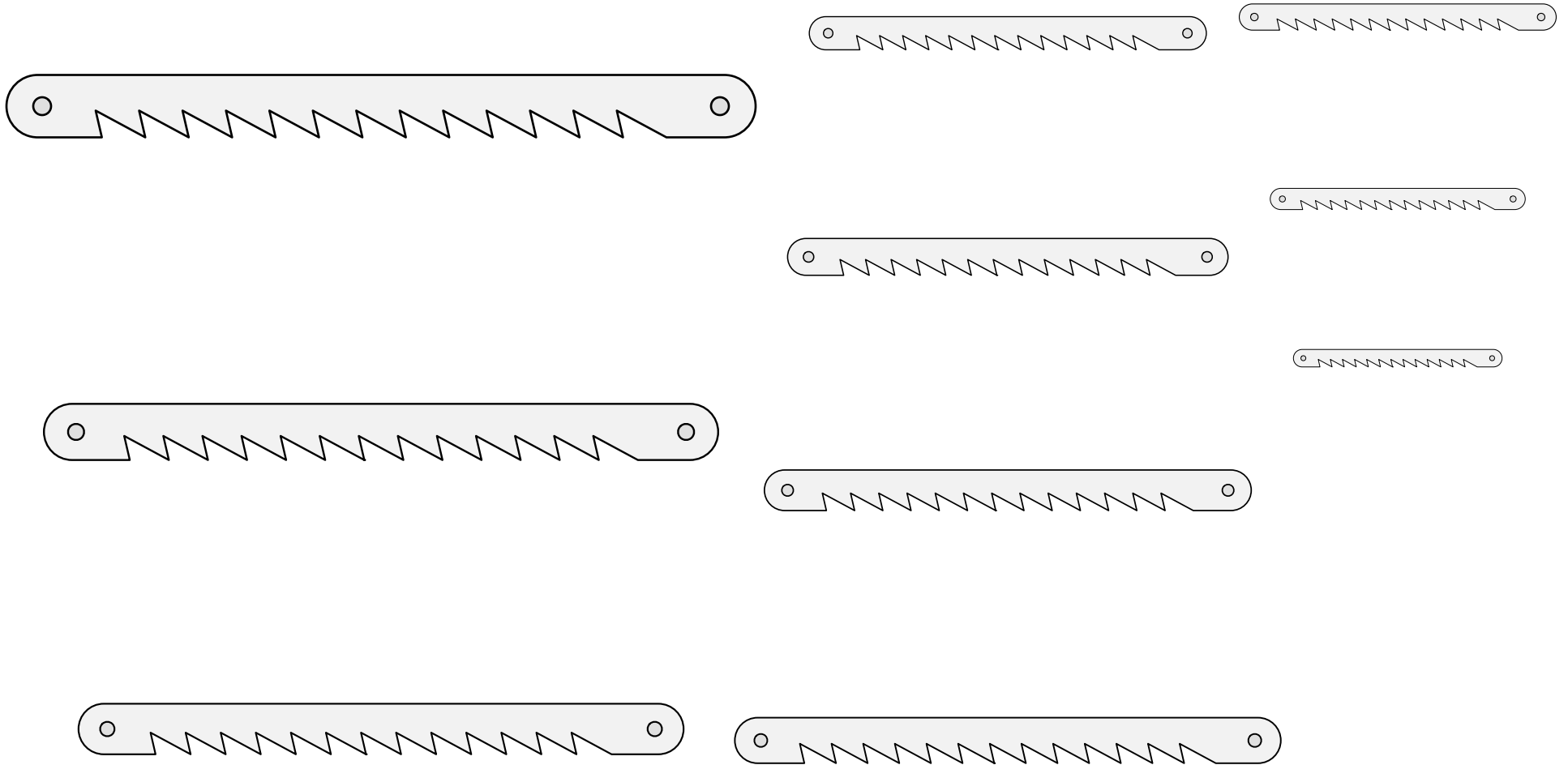

A cutting tool for wood with an indented-edged blade.

Default orientation: fesswise, blade to base. No proper coloration.

Source: Armorial Catalan. Artist unknown. (Folio 34r, arms of Guardiola.)

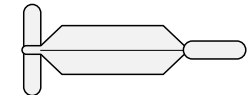
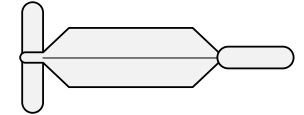
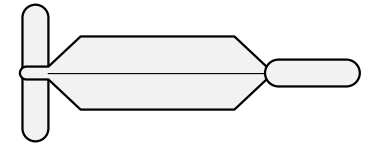
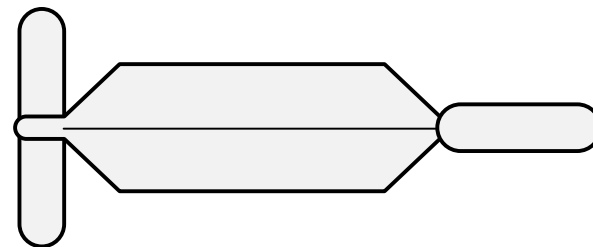
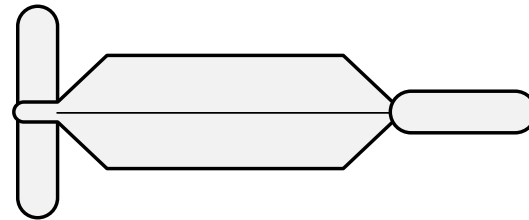
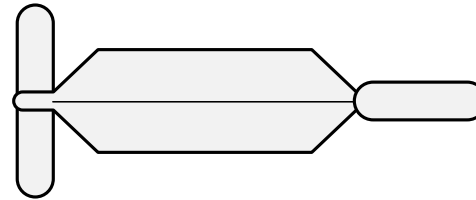
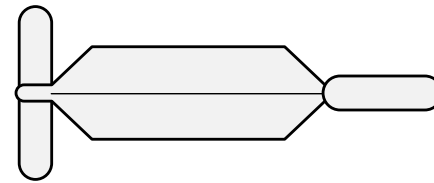
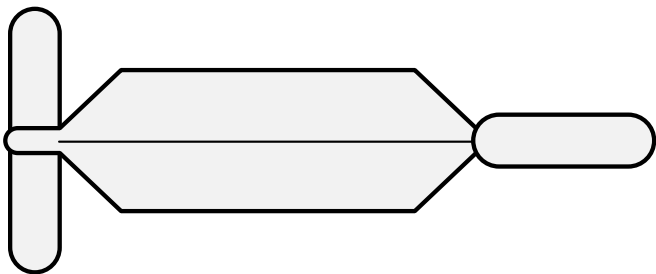
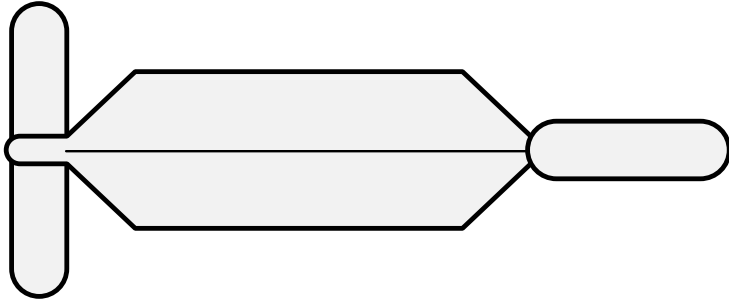
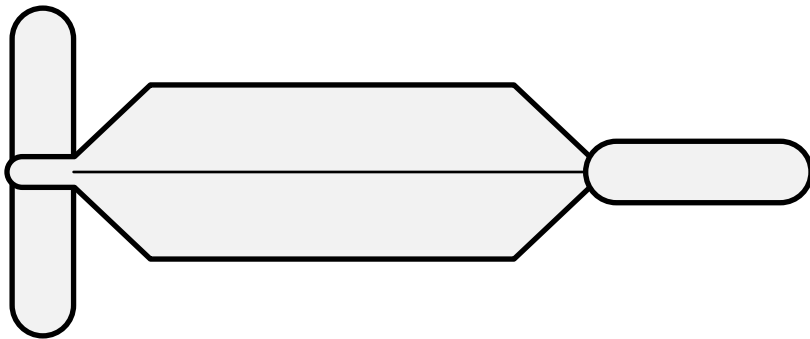

A long straight-edged knife with two handles, used to trim the hair off of hide when making leather.

Default orientation: fesswise. No proper coloration.

Source: The Armes of All the Cheife Corporatons.

Adapted by Mathghamhain Ua Ruadháin.

(From the arms of the Curriers' Company.)

Shave, Currier's (1) 16.118

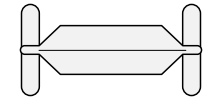
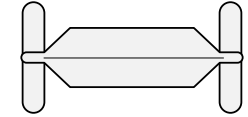
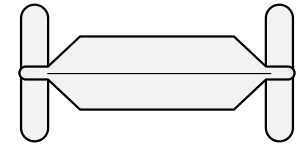
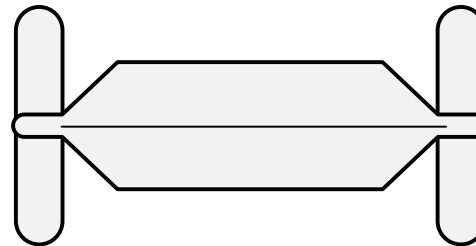
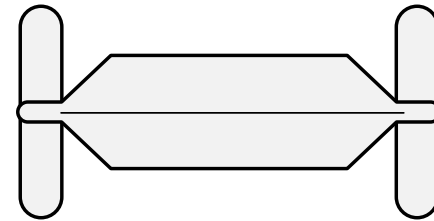
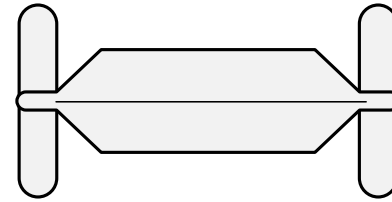
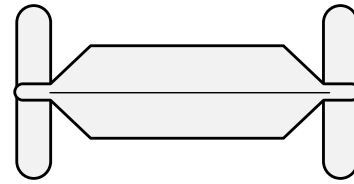
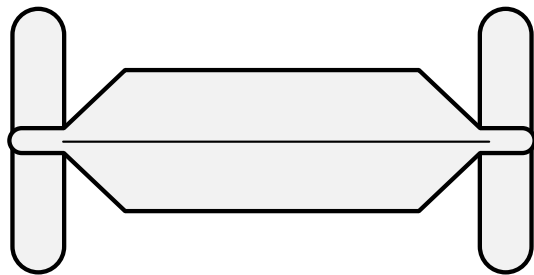
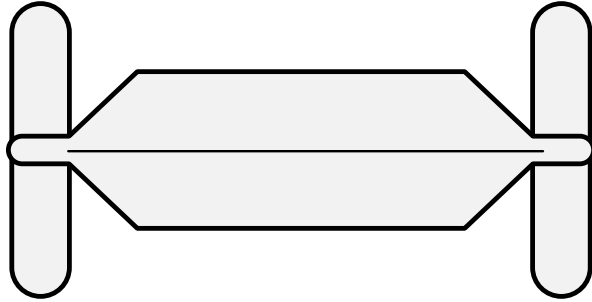
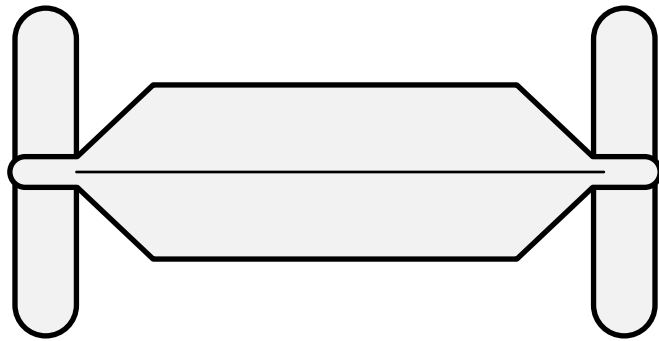

A long straight-edged knife with two handles, used to trim the hair off of hide when making leather.

Default orientation: fesswise. No proper coloration.

Source: The Armes of All the Cheife Corporatons.

Adapted by Mathghamhain Ua Ruadháin.

(From the arms of the Curriers' Company.)

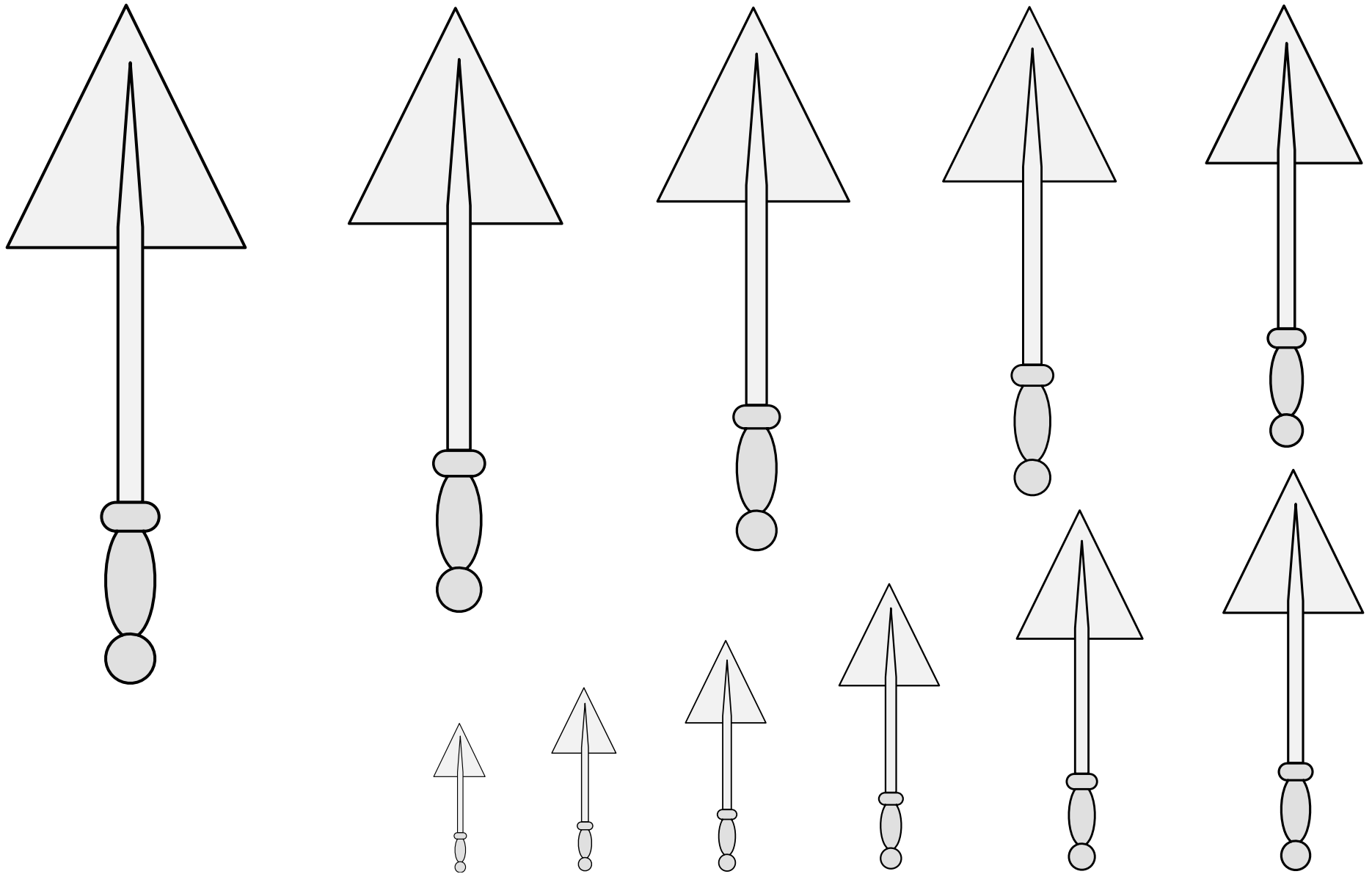

A scraping tool used by plumbers and carpenters with a sharp-edged blade attached to a long handle.

Default orientation: handle to base. Proper coloration unknown.

Source: A Glossary of Terms Used in Heraldry. Artist: James or Irene Parker.

Shavehook 16.120

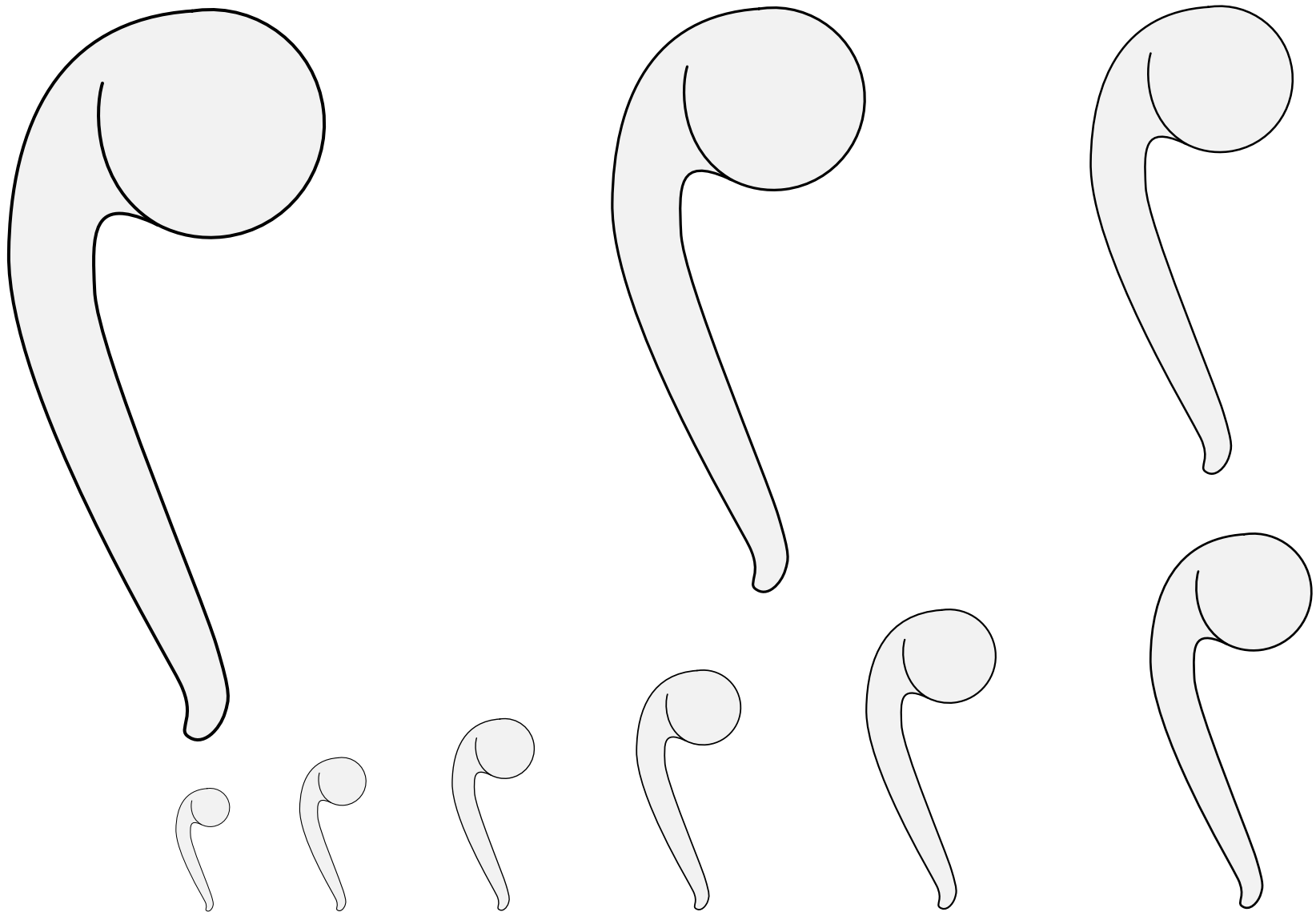

A tool used by medieval plumbers for melting solder to join pipes.
Default orientation unknown. No proper coloration.
Adapted from images of the period arms of the Company of Plumbers.

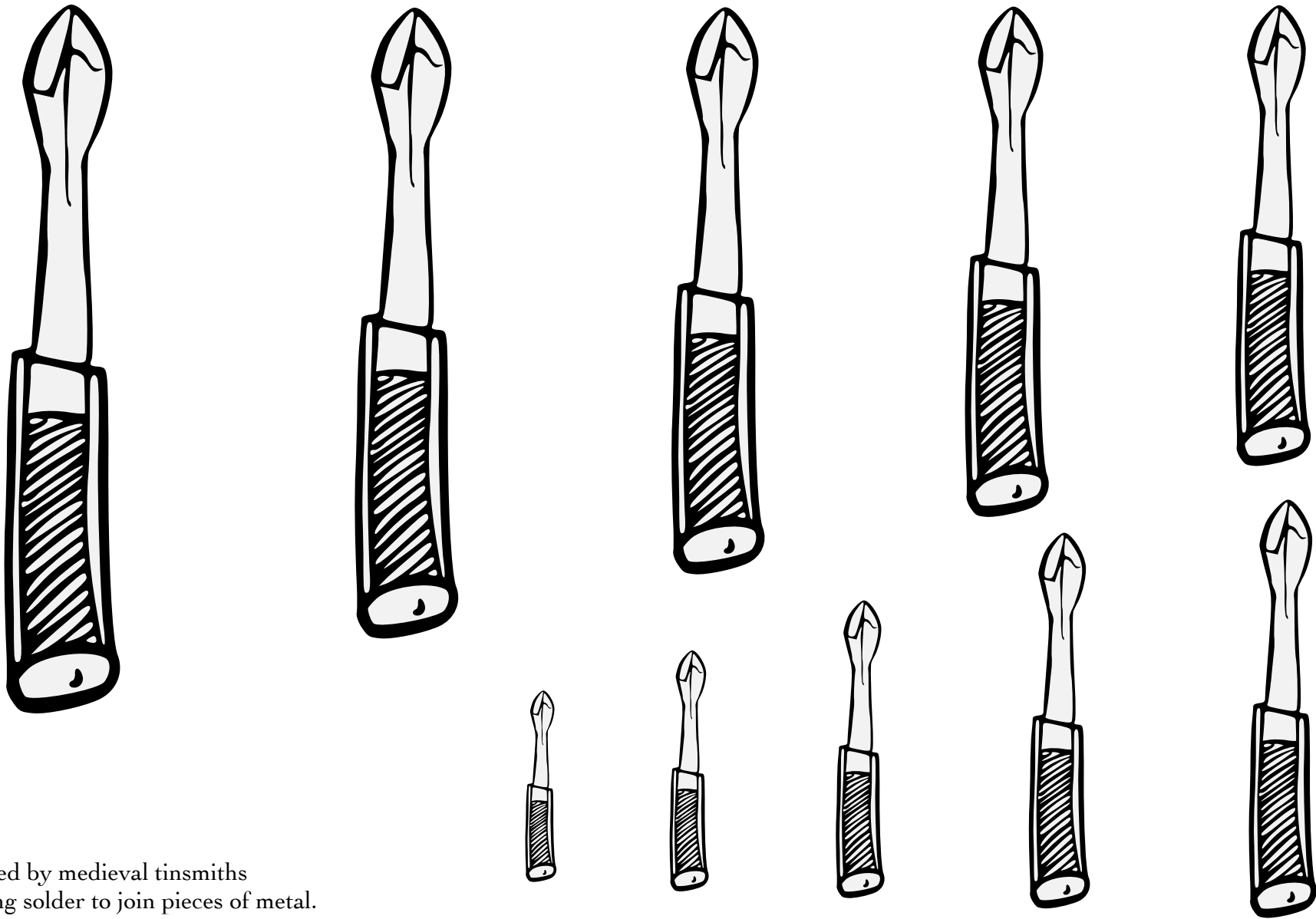

A tool used by medieval tinsmiths for melting solder to join pieces of metal.

Default orientation unknown. No proper coloration.

Source: Die Hausbücher der Nürnberger Zwölfbrüderstiftungen.

Artist unknown. (Mendel I, folio 155v.)

Adapted by Thora Brandsdottir.

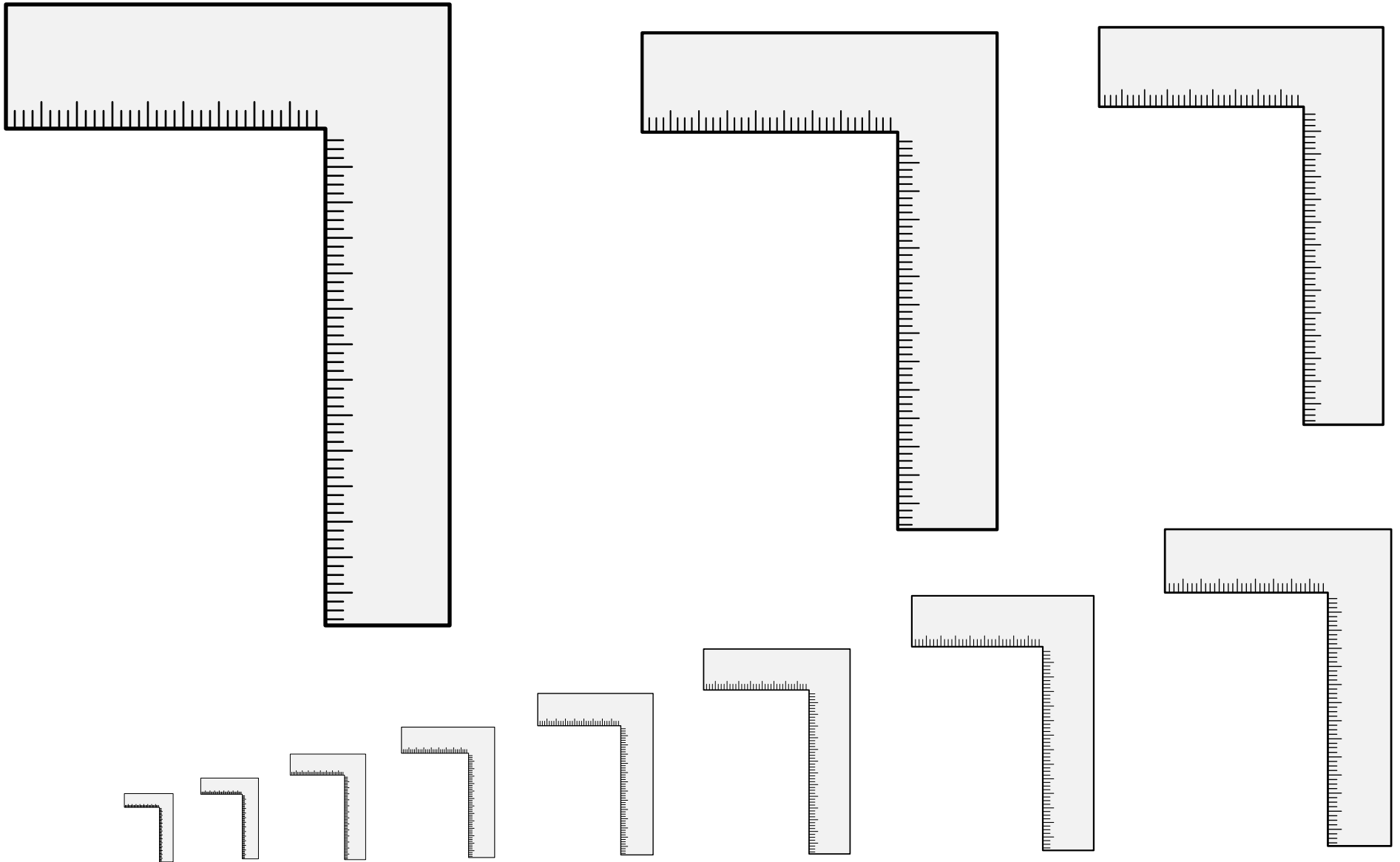

A woodworker's measurement tool, used to mark right angles.
No default orientation: No proper coloration.

Square, Carpenter's (1) 16.123

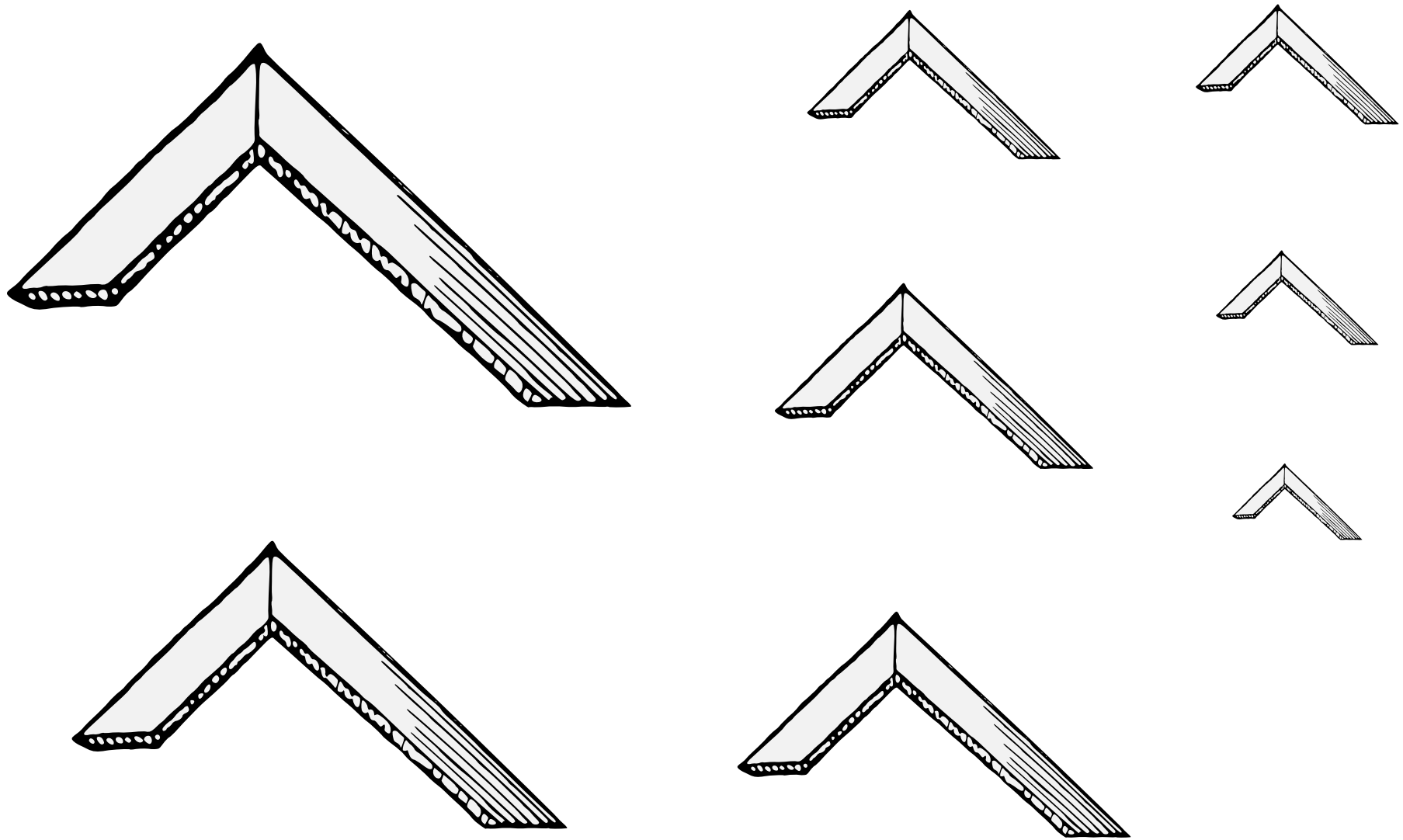

A woodworker's measurement tool, used to mark right angles.

No default orientation:. No proper coloration.

Source: Nobleza del Andaluzia. Artist unknown.
(Arms of Bracamonte, folio 211r.)

Square, Carpenter's (2) 16.124

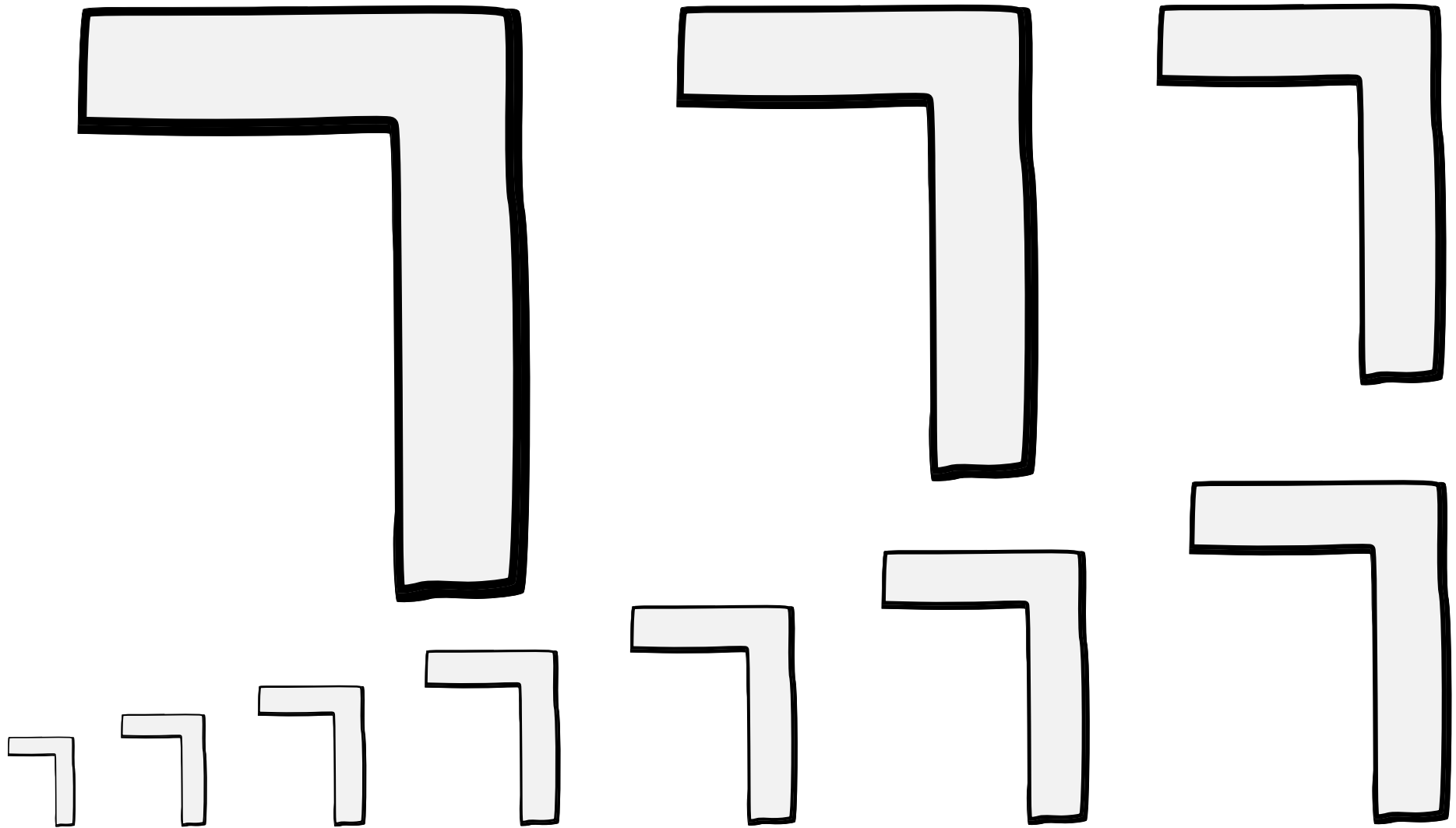

A woodworker's measurement tool, used to mark right angles.

No default orientation: No proper coloration.

Source: Guillim's Display of Heraldry. Artist unknown.

Square, Carpenter's (3) 16.125

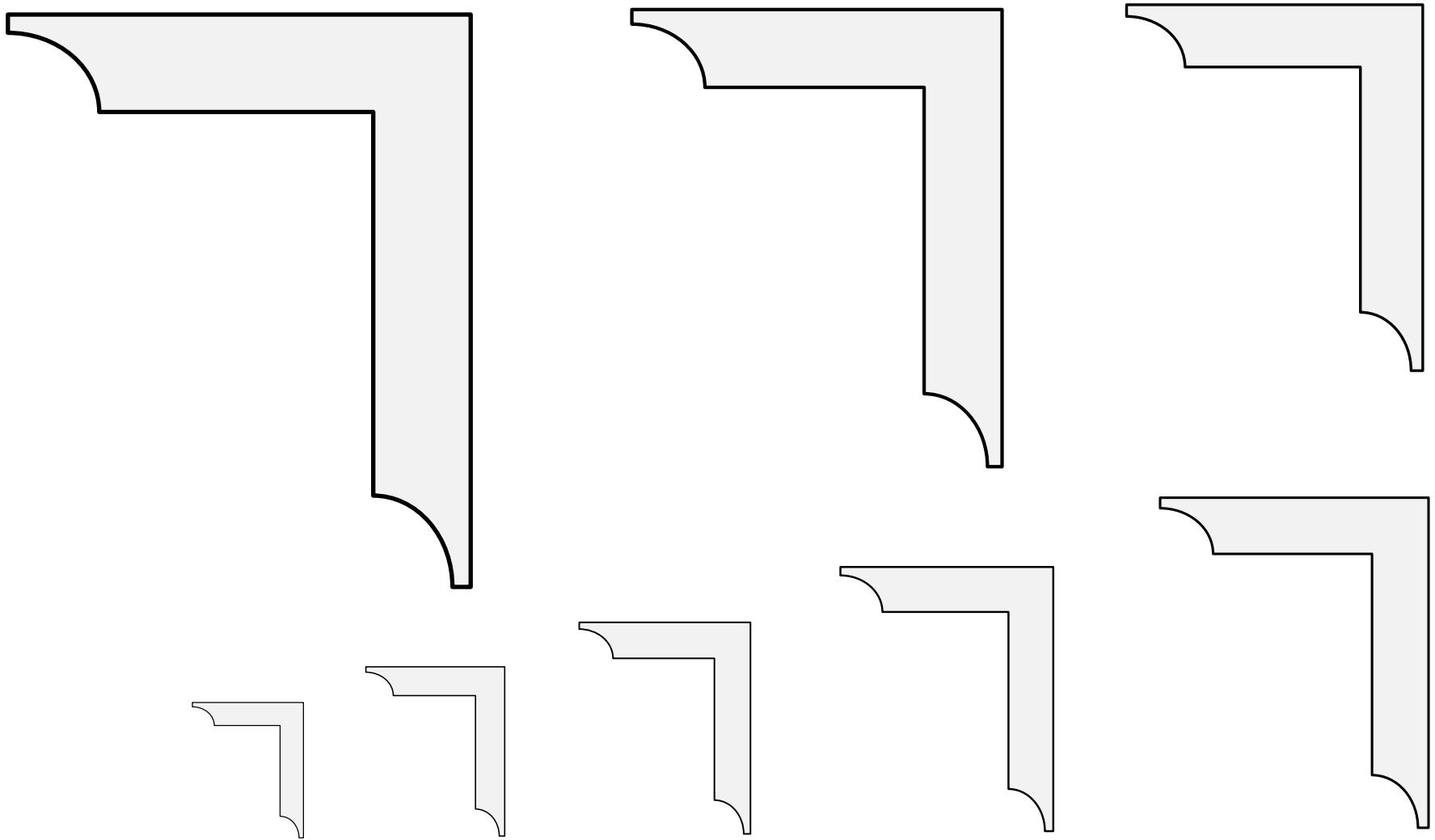

A woodworker's measurement tool, used to mark right angles.
No default orientation: No proper coloration.

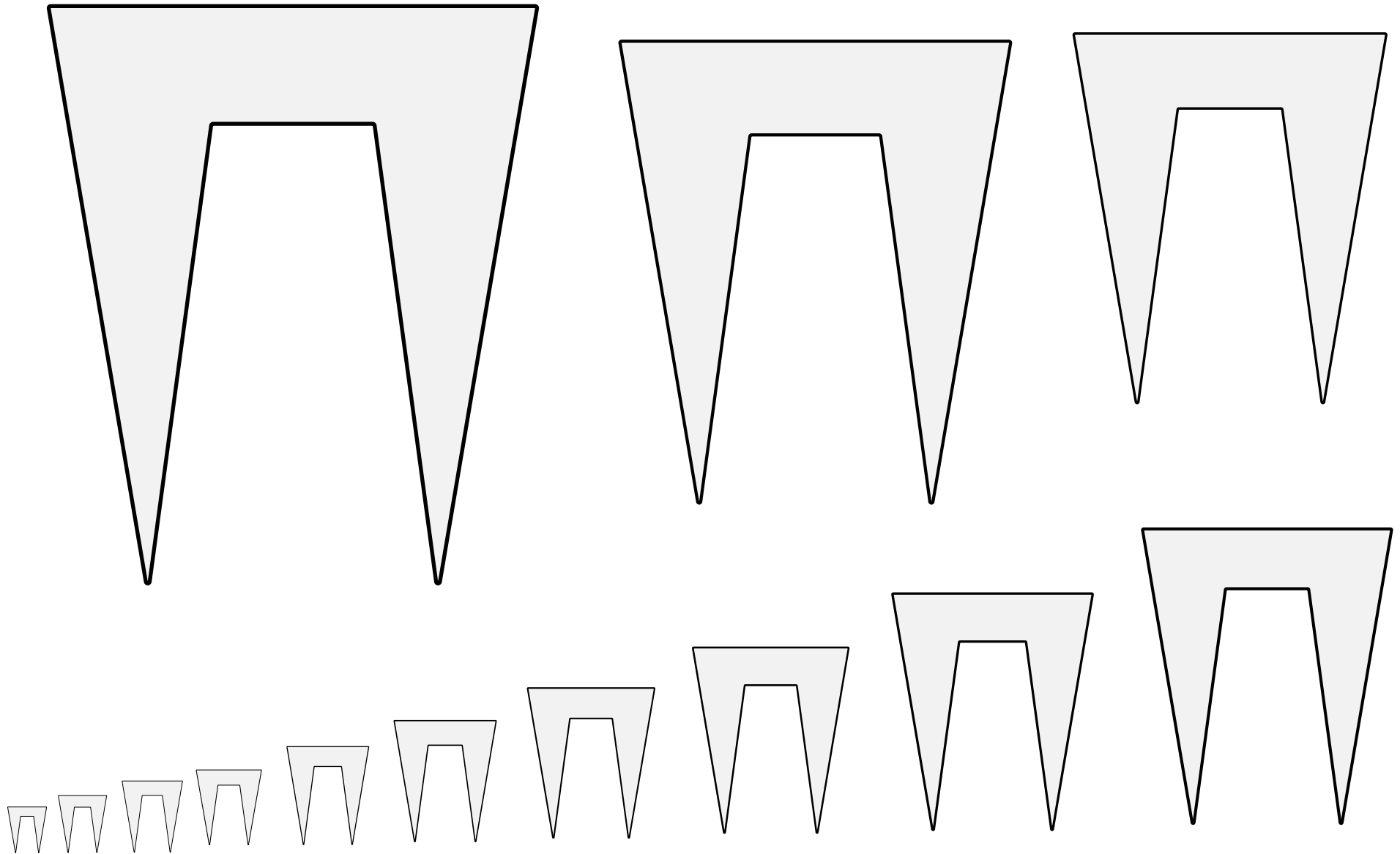

A two-pointed nail, used to attach items to a surface.
Default orientation: points to base. No proper coloration.
Source: Banners, Standards, and Badges. Artist: Thomas Willement.

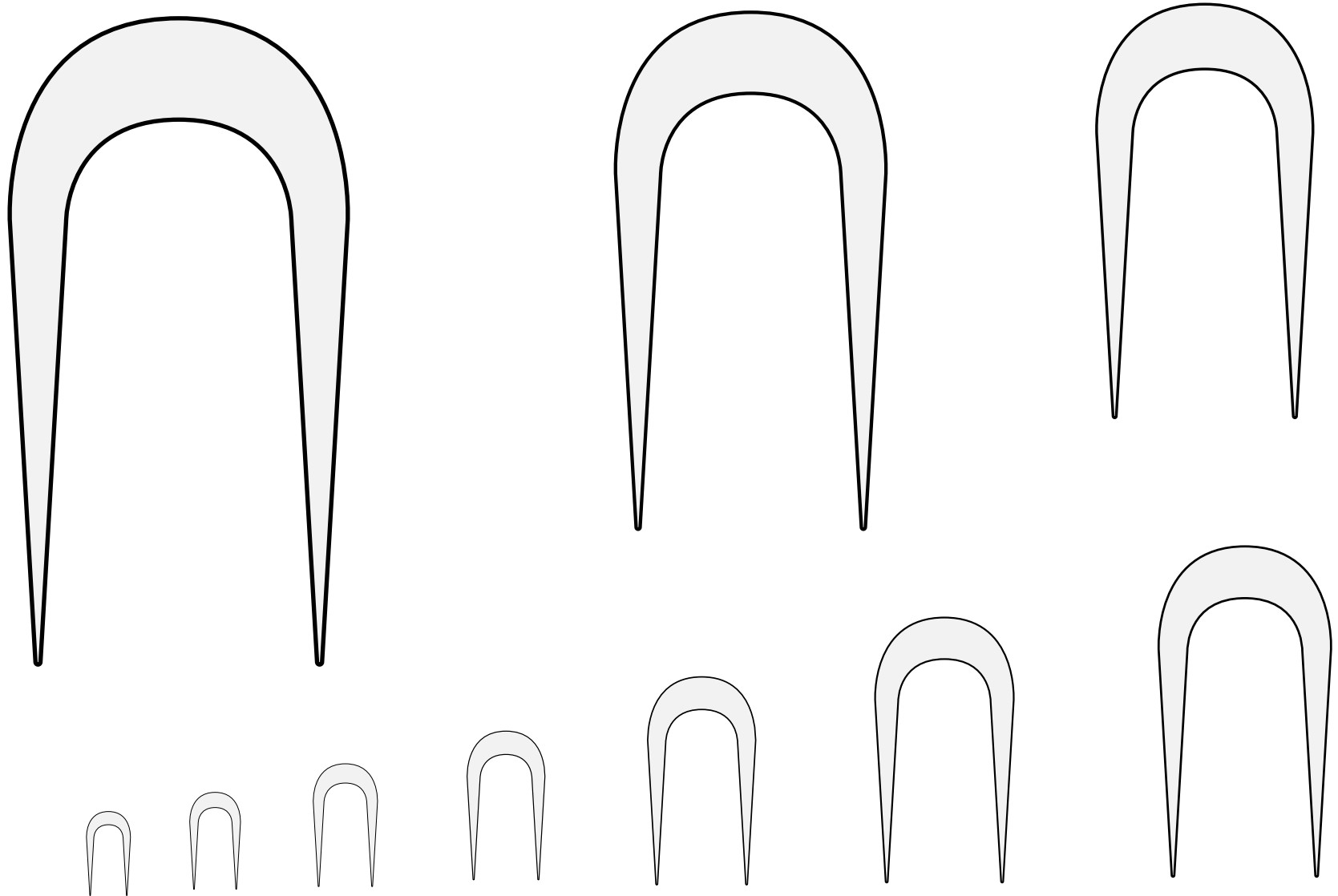

A two-pointed nail, used to attach items to a surface.
Default orientation: points to base. No proper coloration.
Source: Fenwick Roll. Artist unknown. (Arms of Stapleton.)

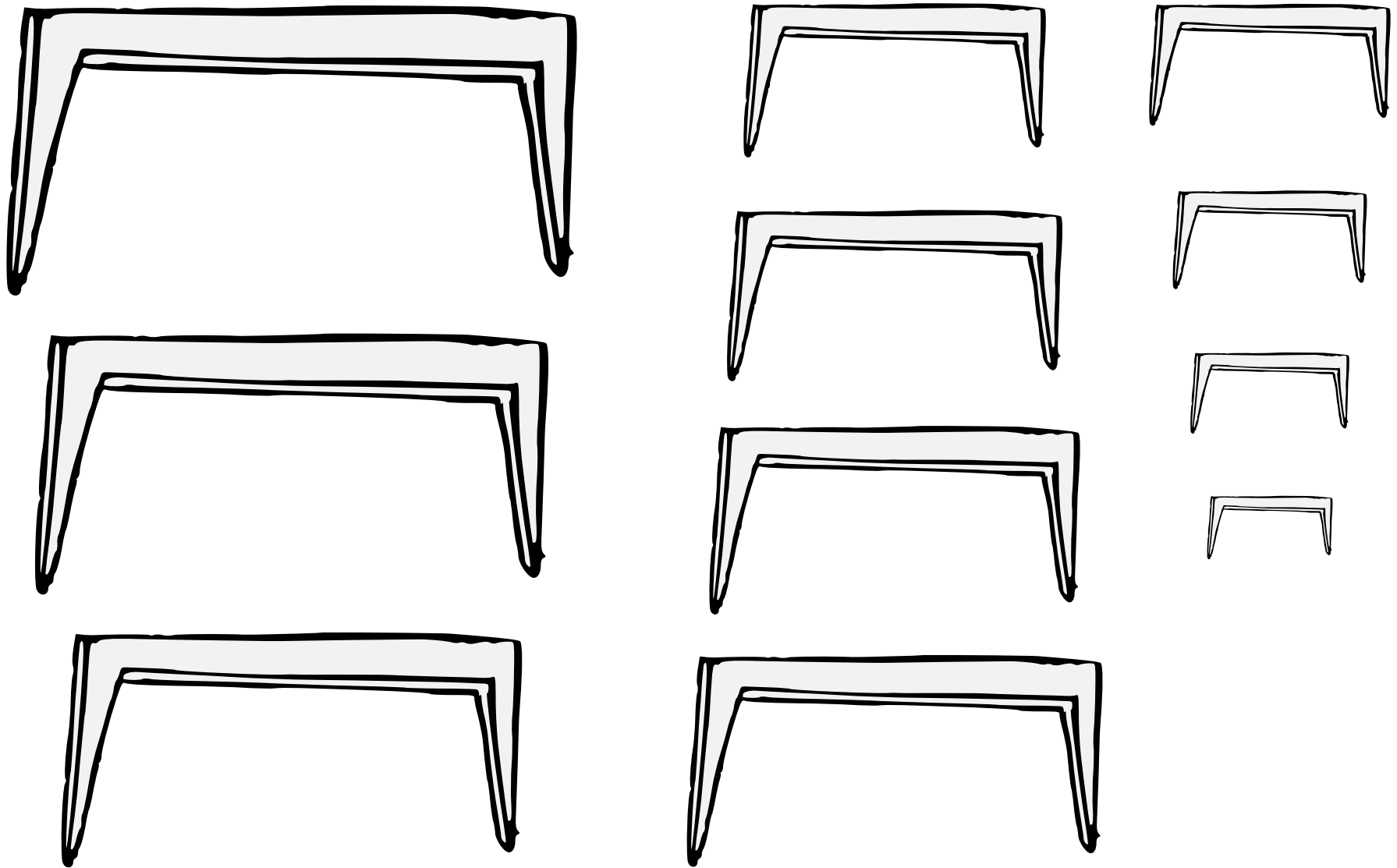

A two-pointed nail, used to attach items to a surface.

Default orientation: points to base. No proper coloration.

Source: Arma Regni Poloniae. Artist unknown. (Herb of Cholieva, p. 83.)

Staple (3) 16.129

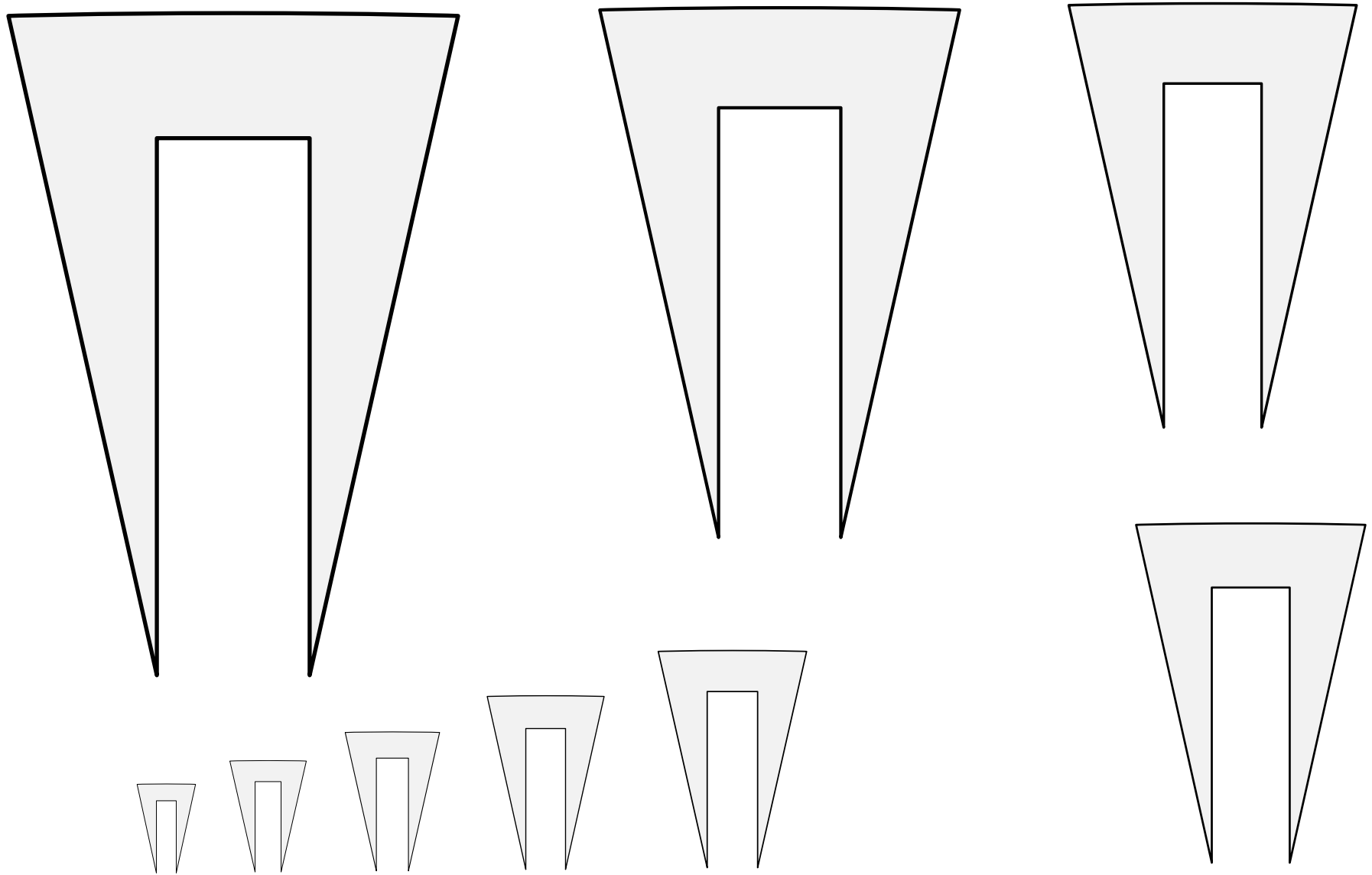

A two-pointed nail, used to attach items to a surface.
Default orientation: points to base. No proper coloration.
Source: English Arms A. Artist unknown. (Page 67.)

Staple (4) 16.130

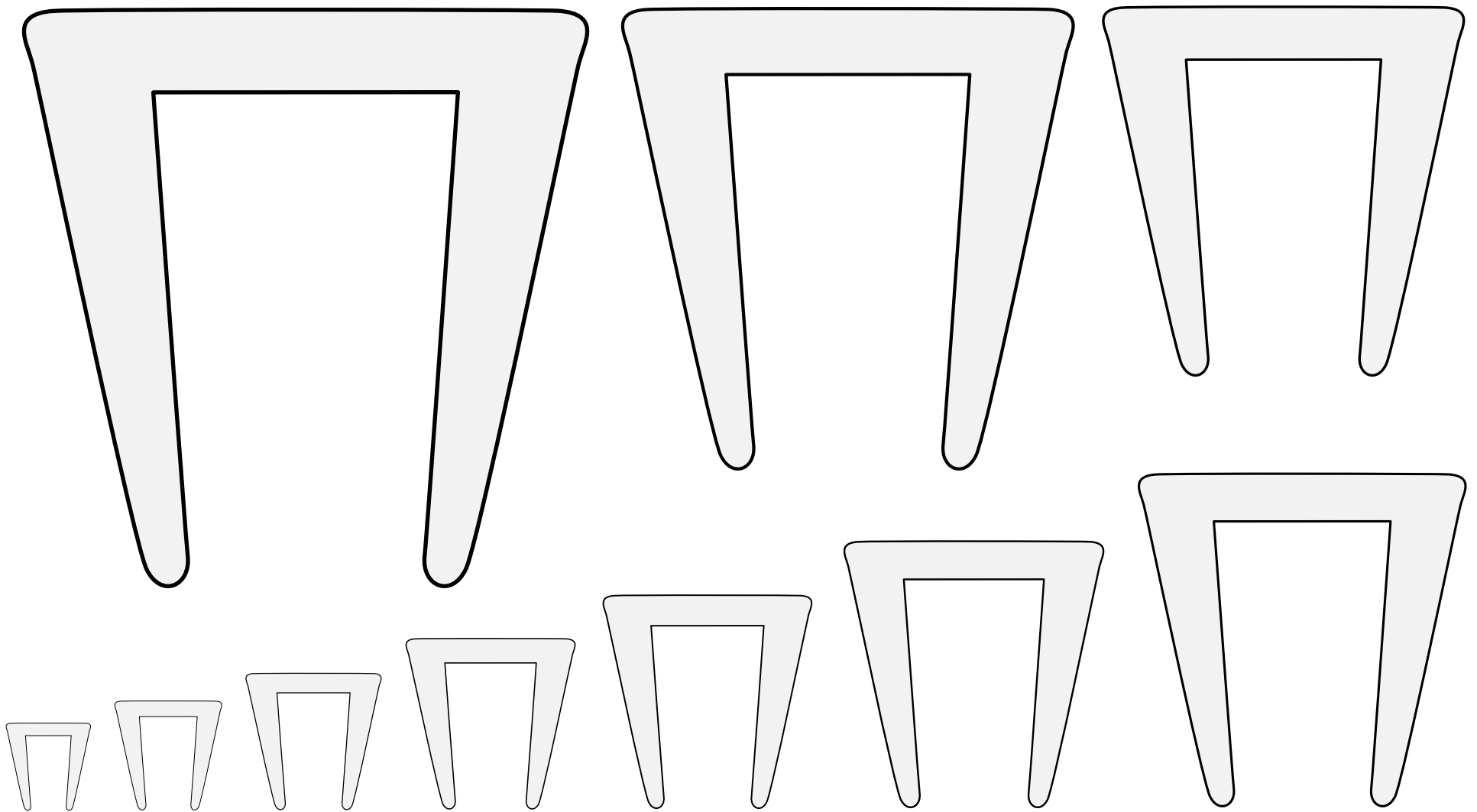

A two-pointed nail, used to attach items to a surface.
Default orientation: points to base. No proper coloration.
Source: Queens College MS 72. Artist unknown. (Folio 62r.)

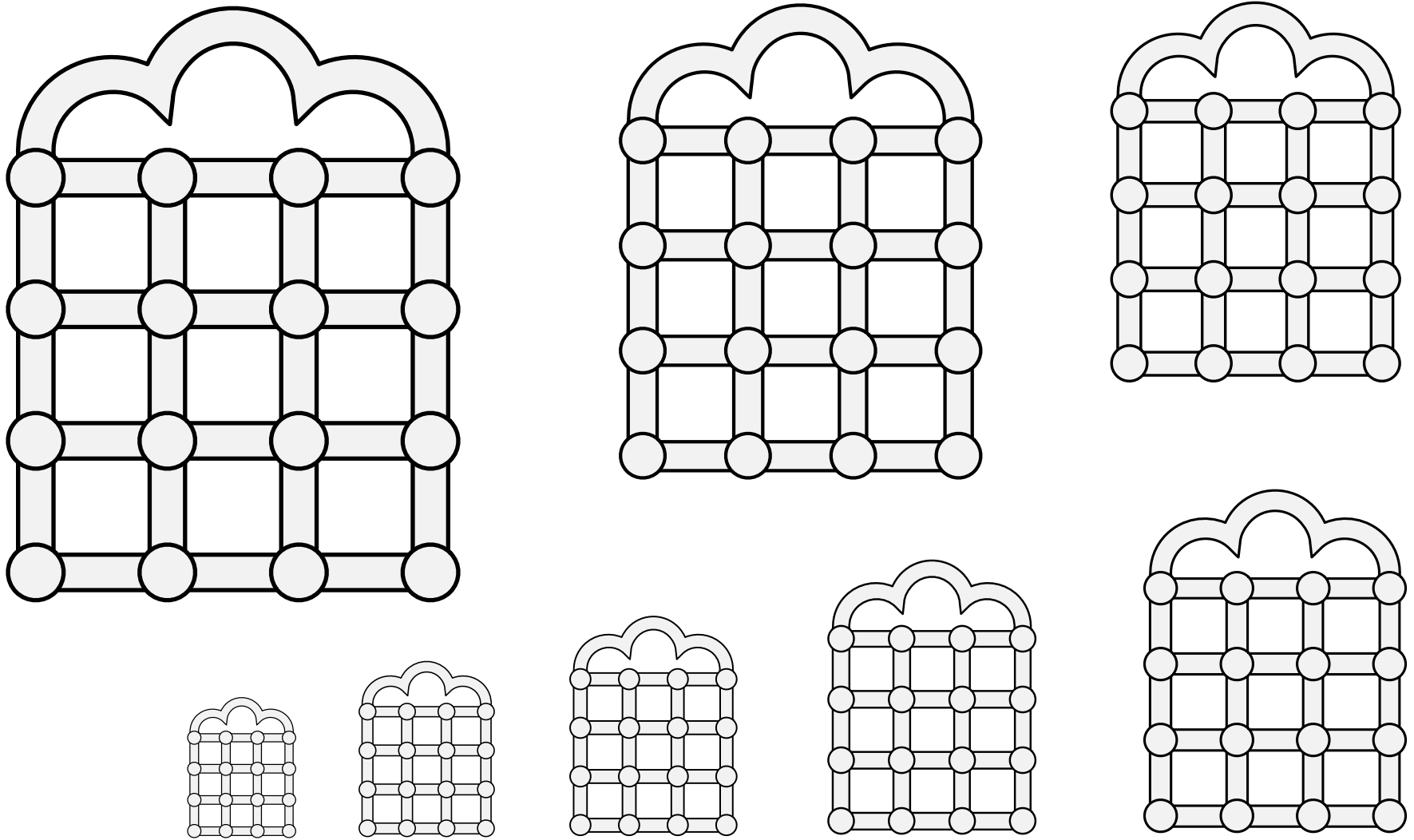

A set of pewter balls joined into a matrix.

Default orientation: carrying handle to chief. No proper coloration.

Source: The Armes of All the Cheife Corporatons.

Adapted by Mathghamhain Ua Ruadháin.

(From the arms of the Pewterers' Company.)

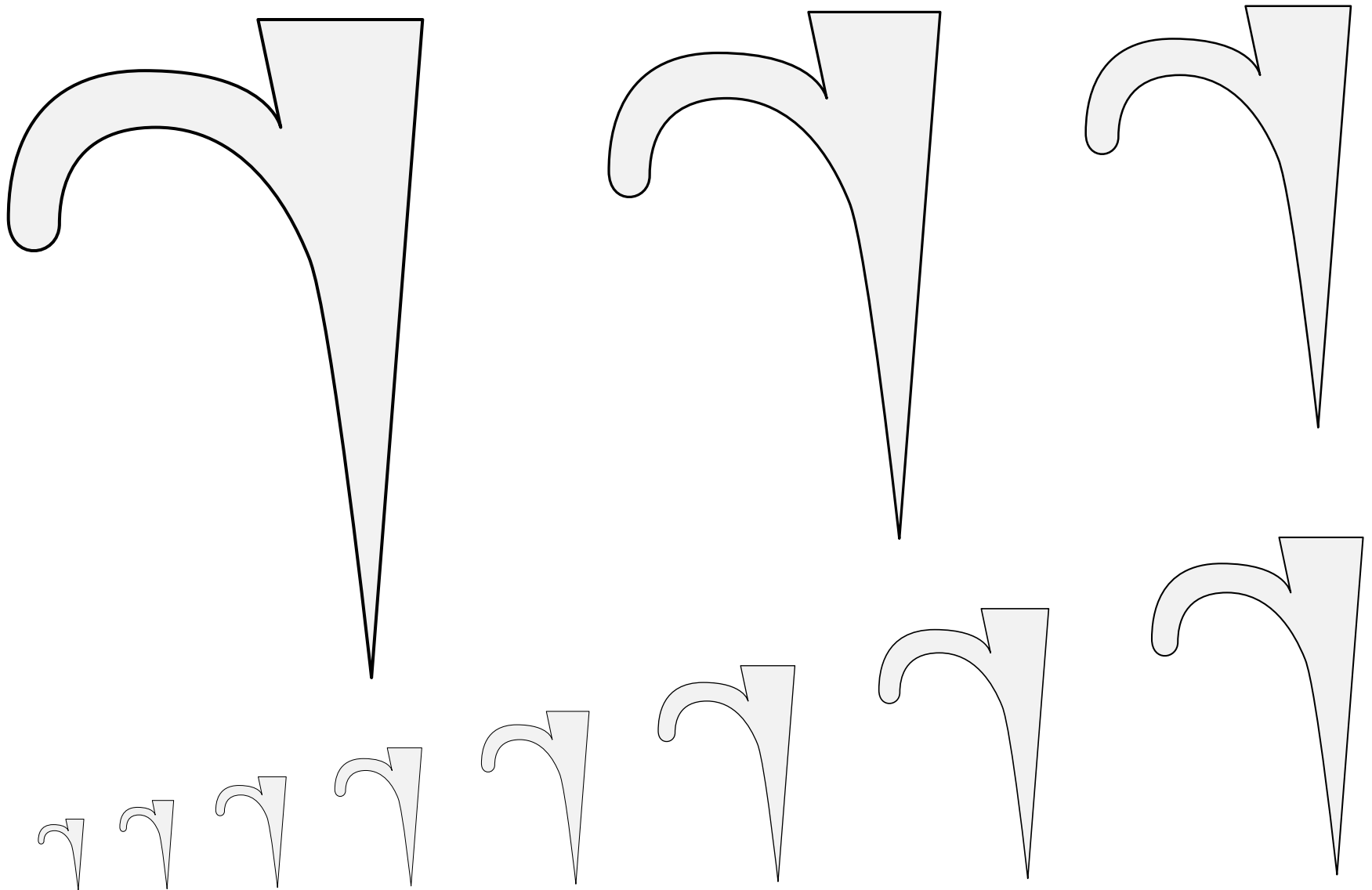

A specialized form of nail used to pin the edges of fabric to a frame to ensure it keeps its shape while drying.

Default orientation: point to base. No proper coloration.

Source: A Glossary of Terms Used in Heraldry. Artist: James or Irene Parker.

Genterhook (1) 16.133

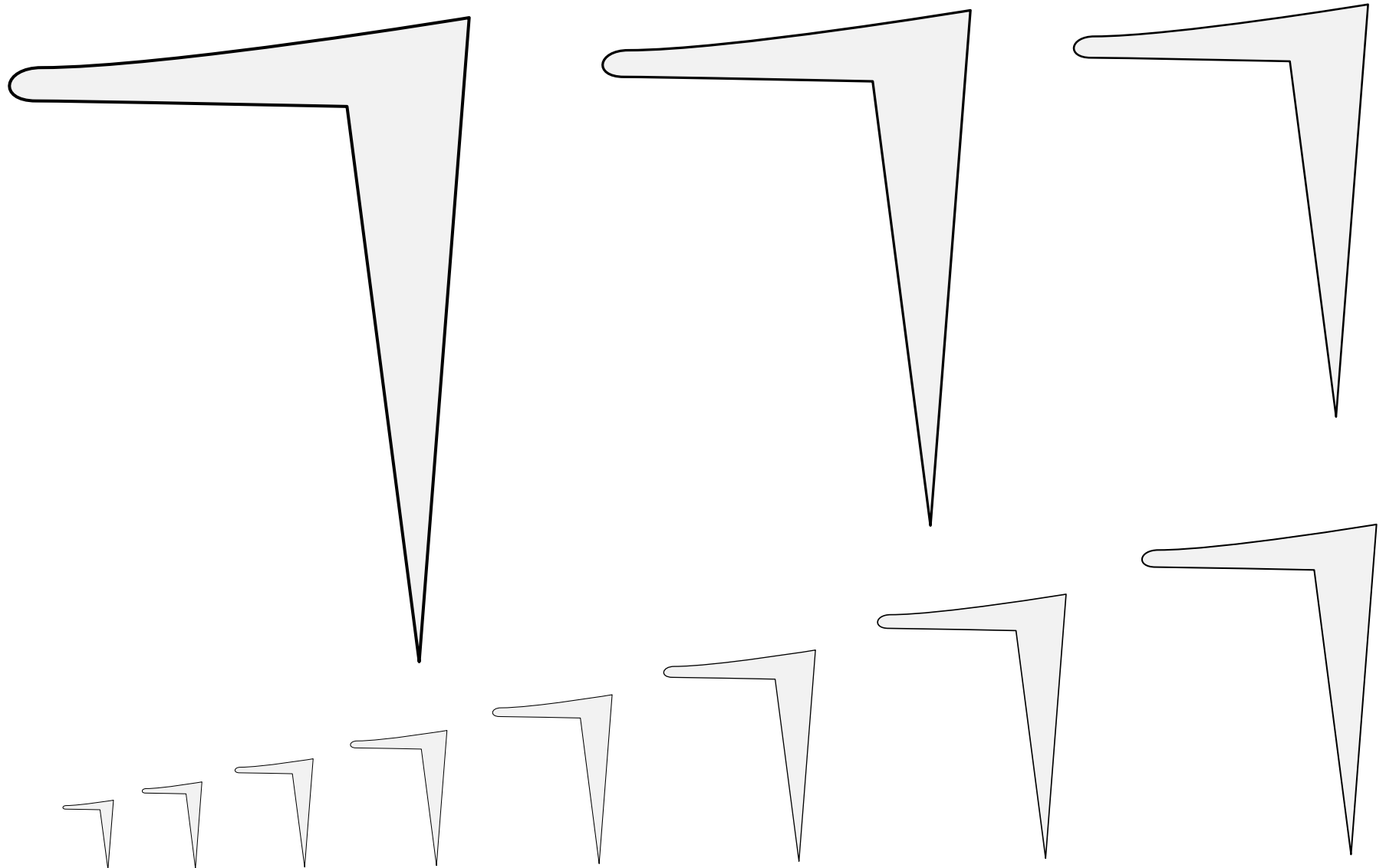

A specialized form of nail used to pin the edges of fabric to a frame to ensure it keeps its shape while drying.

Default orientation: point to base. No proper coloration.

Source: A Glossary of Terms Used in Heraldry. Artist: James or Irene Parker.

Genterhook (2) 16.134

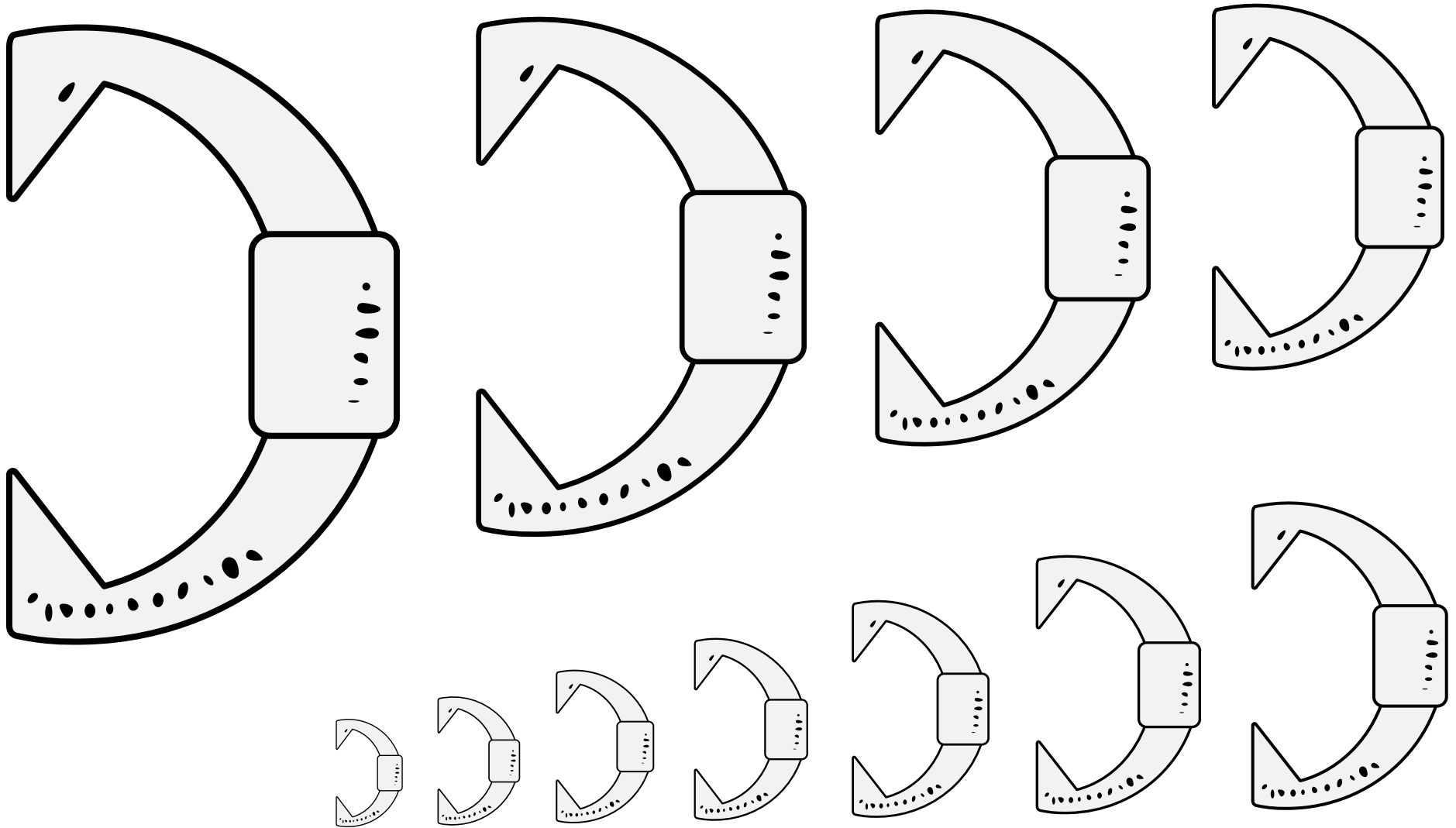

A specialized form of nail used to pin the edges of fabric to a frame to ensure it keeps its shape while drying.

Default orientation: point to base. No proper coloration.

Source: The Book of Public Arms. Artist unknown.
(Arms of the Clothworkers Company, page 193.)

Genterhook (3) 16.135

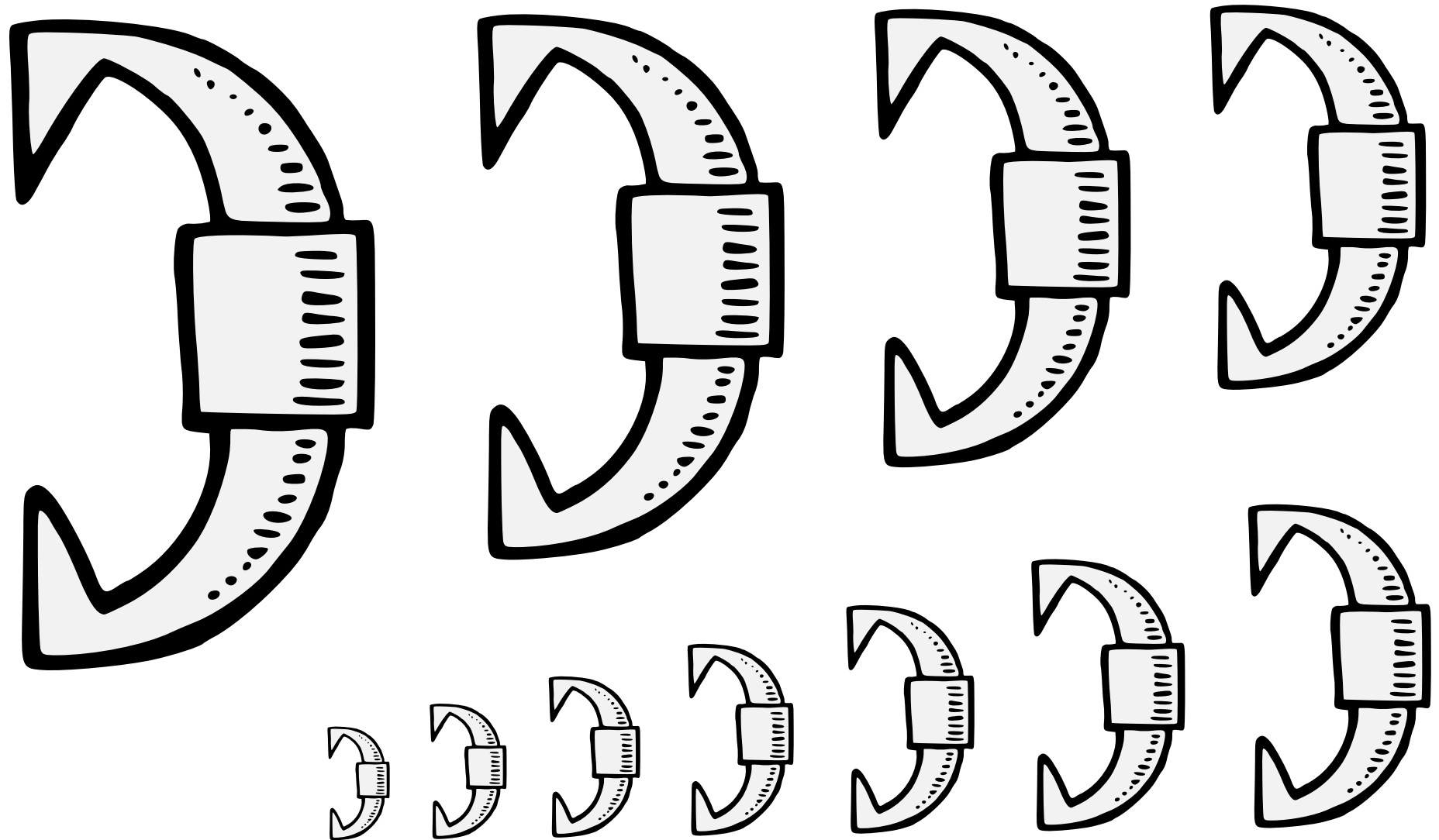

A specialized form of nail used to pin the edges of fabric to a frame to ensure it keeps its shape while drying.

Default orientation: point to base. No proper coloration.

Source: The Book of Public Arms. Artist unknown.
(Arms of the Edinburgh Waulkers Company, page 837.)

Genterhook (4) 16.136

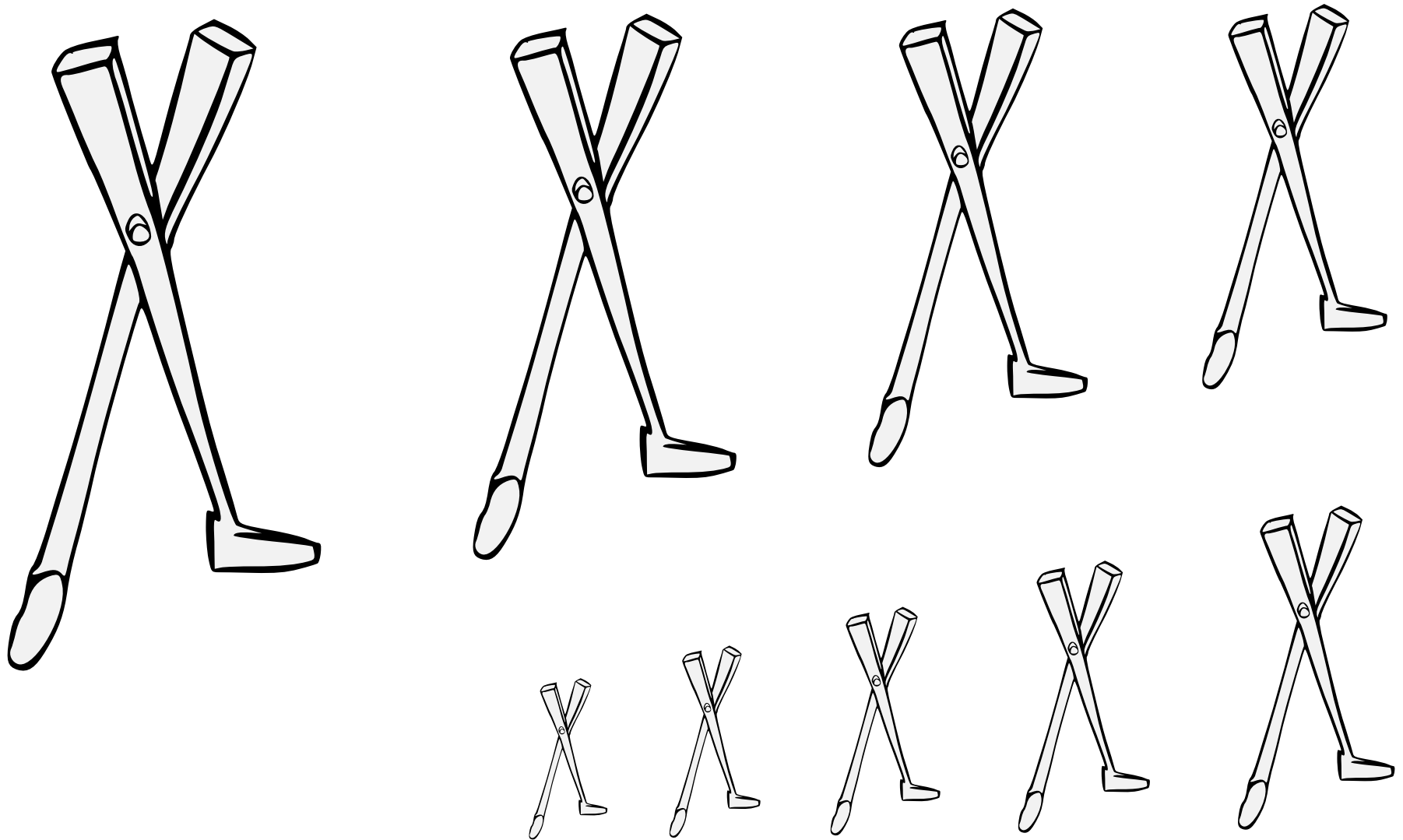

A gripping tool.

Default orientation: handles to base. No proper coloration.

Source: Die Hausbücher der Nürnberger Zwölfbrüderstiftungen.
Artist unknown. (Mendel I, folio 155v.) Adapted by Thora Brandsdottir.

Tongs, Tinsmith's 16.137

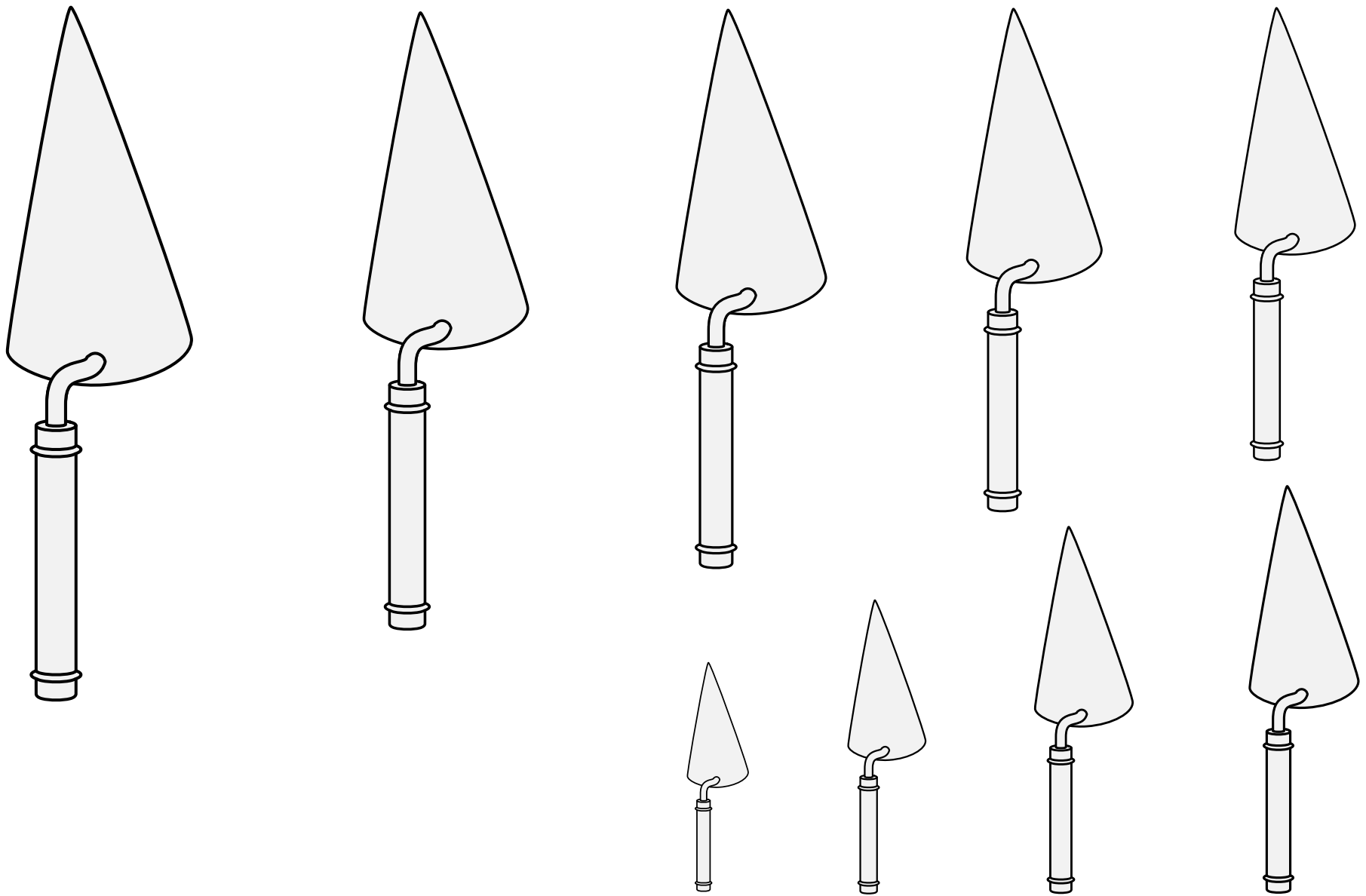

A very small shovel, such as might be used in gardening or construction.
Default orientation: palewise, handle to base. No proper coloration.

Trowel (1) 16.138

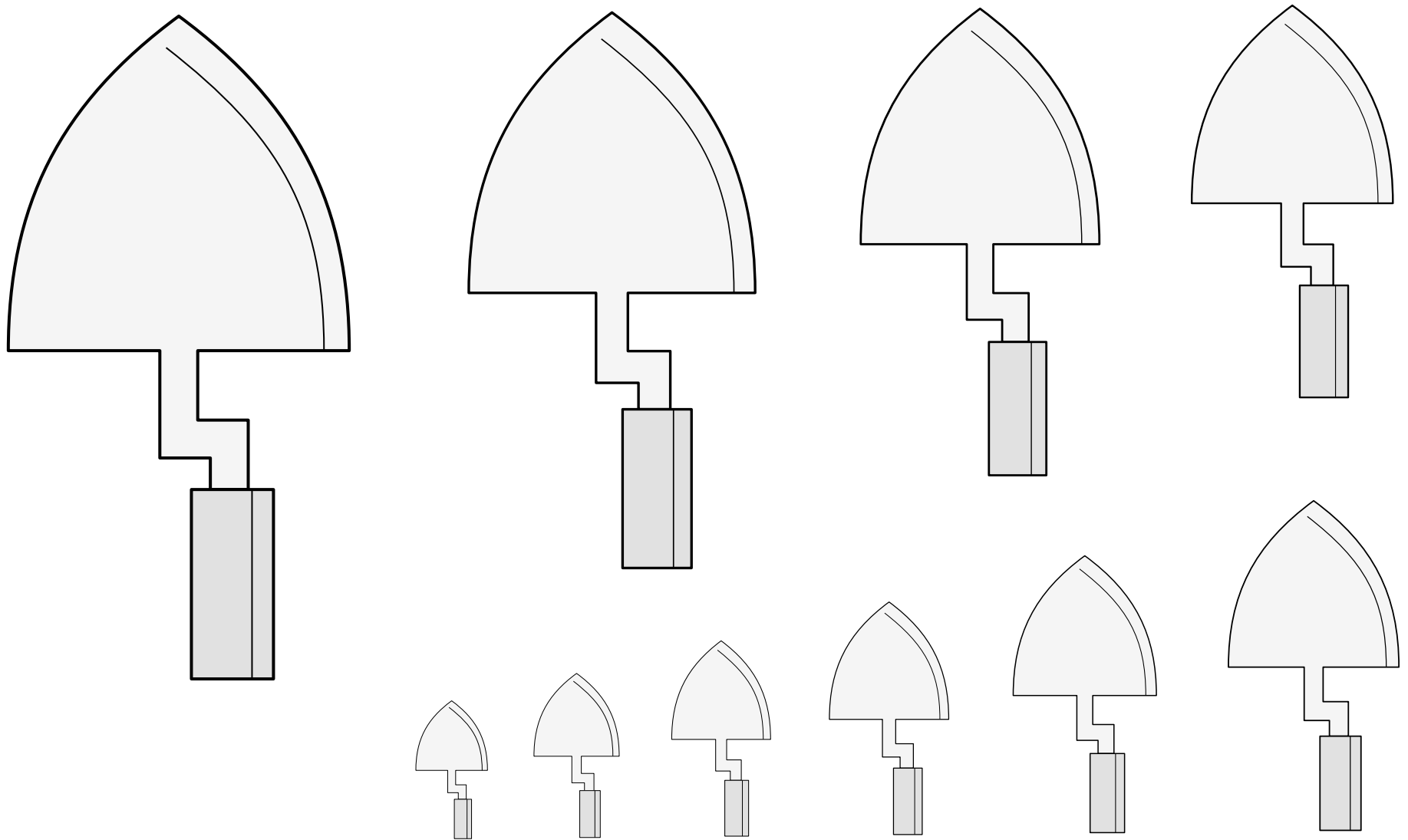

A very small shovel, such as might be used in gardening or construction.

Default orientation: palewise, handle to base. No proper coloration.

Source: A Display of Heraldry. Artist: John Guillim.
(Manuscript folio 105r.) Adapted by Iago ab Adam.

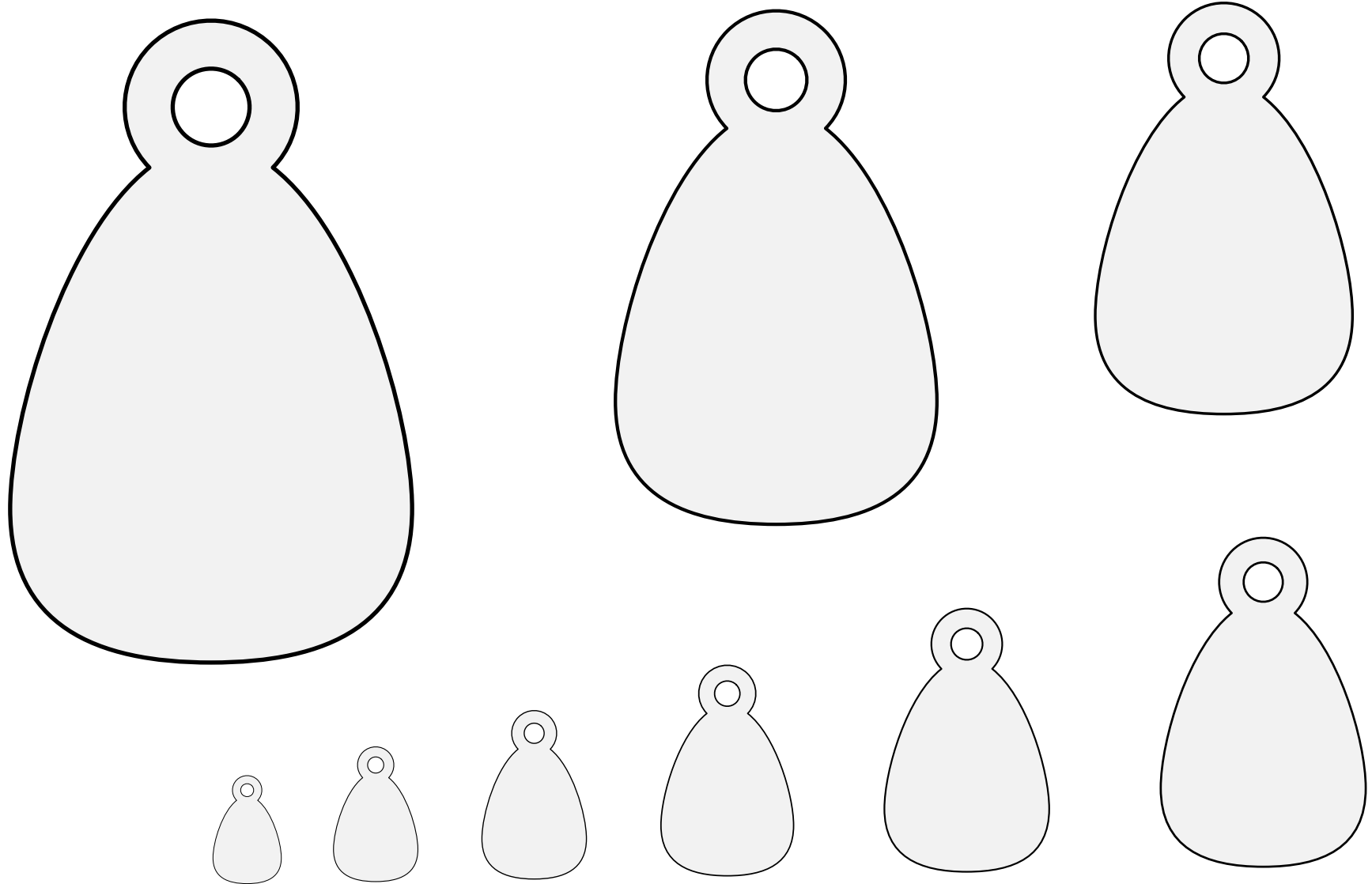

A small lump of metal of a known mass, used when balancing scales to weigh something.

Default orientation: hole to chief. No proper coloration.

Source: Stemmario Trivulziano. Artist: Gian Antonio da Tradate.
(Arms of de Ponzio, page 274.)

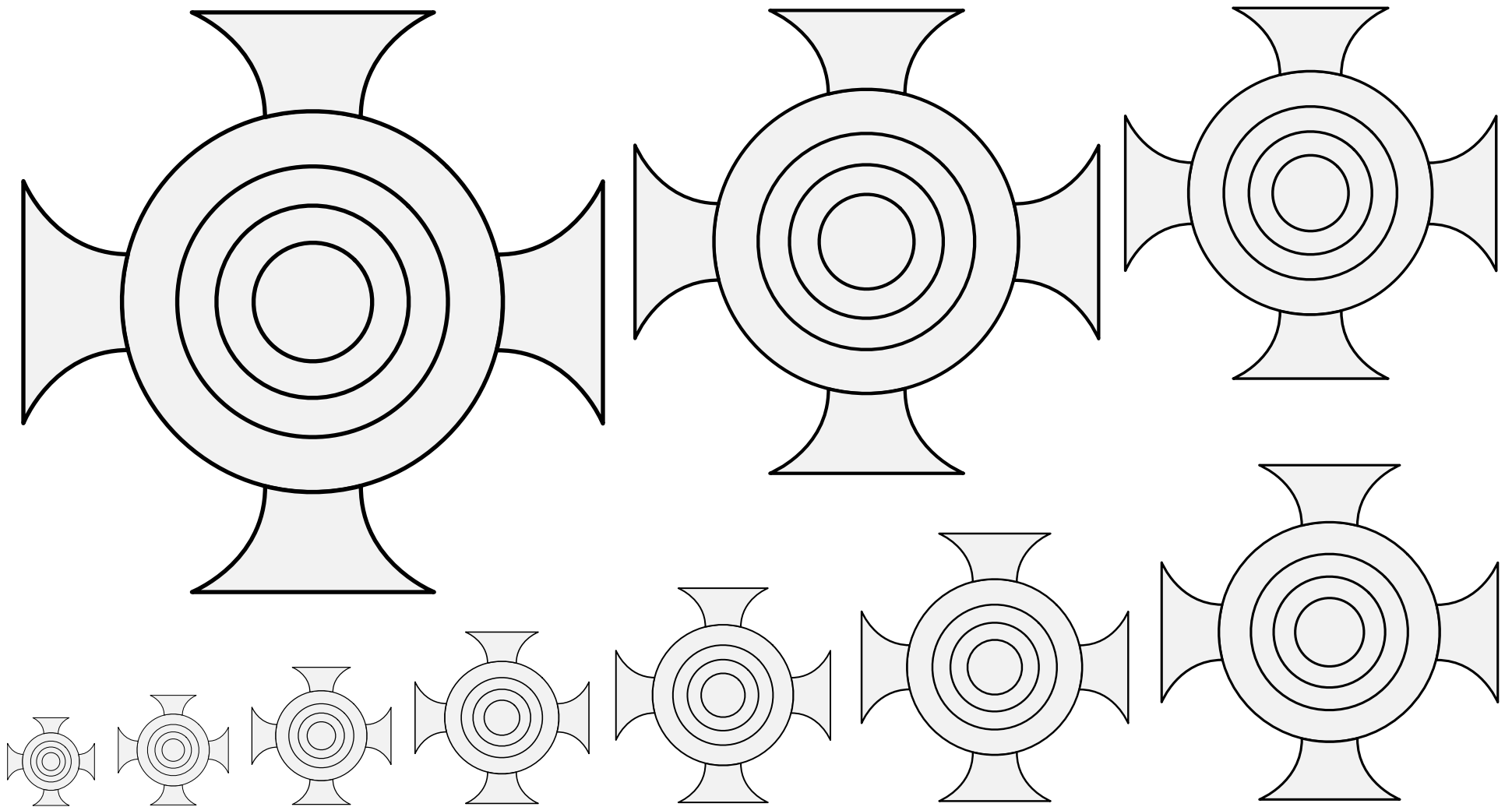

A group of stackable metal cups of carefully defined weights, with a sometimes-elaborate lid that holds them together.
Used with a balance from the Roman period through the Renaissance. Found in Iberian armory where it is blazoned a "mark."
(This charge was previously misidentified as an archery target, which can also be called a mark.)
Artist: Elizabeth Turner de Carlisle.

Weights, Set of Nesting Scale (1) 16.141

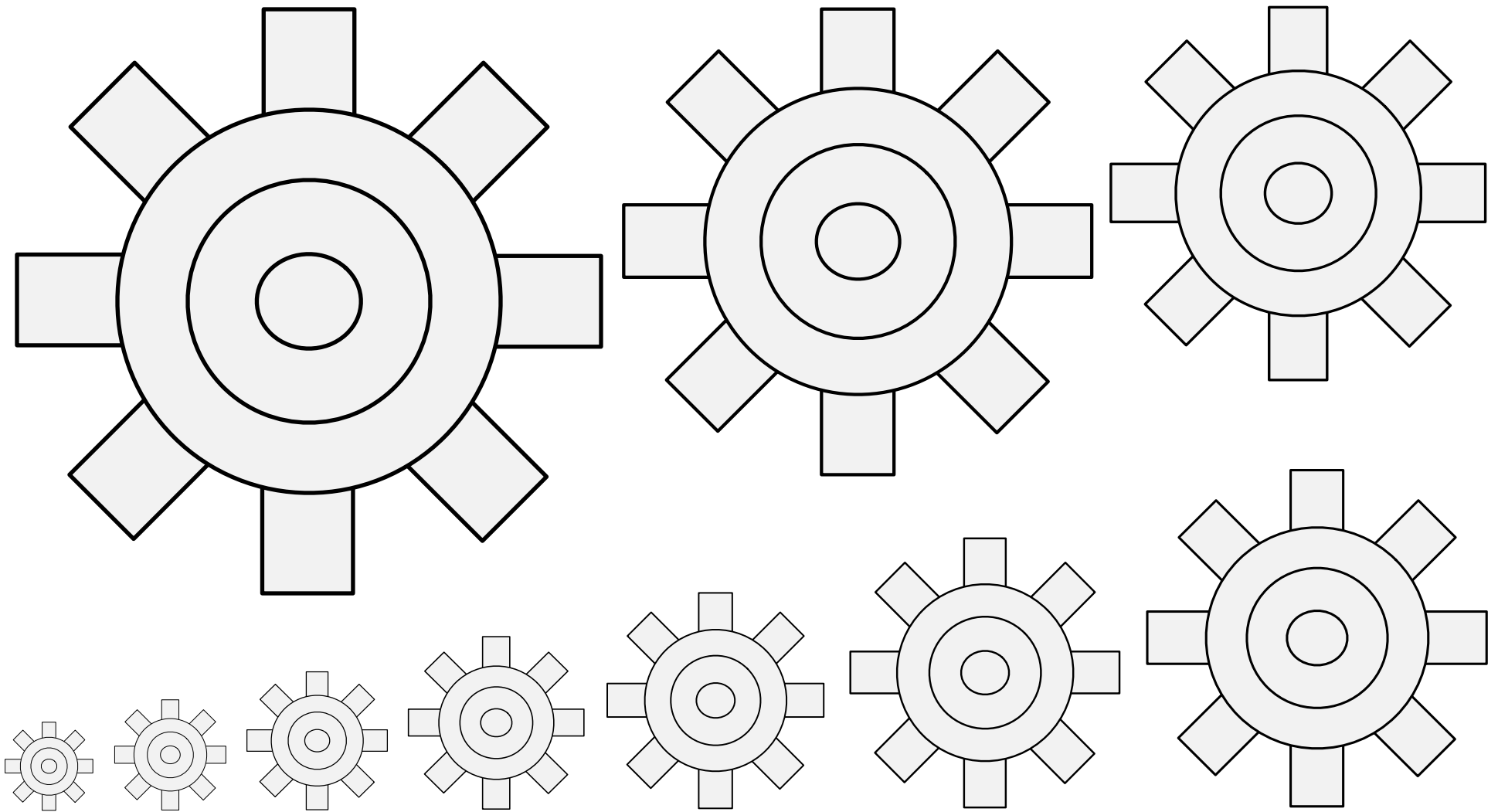

A group of stackable metal cups of carefully defined weights, with a sometimes-elaborate lid that holds them together. Used with a balance from the Roman period through the Renaissance. Found in Iberian armory where it is blazoned a "mark."
(This charge was previously misidentified as an archery target, which can also be called a mark.)
Source: Libro de Armas y Blasones de Diversos Linajes y Retratos. Artist unknown.

Weights, Set of Nesting Scale (2) 16.142

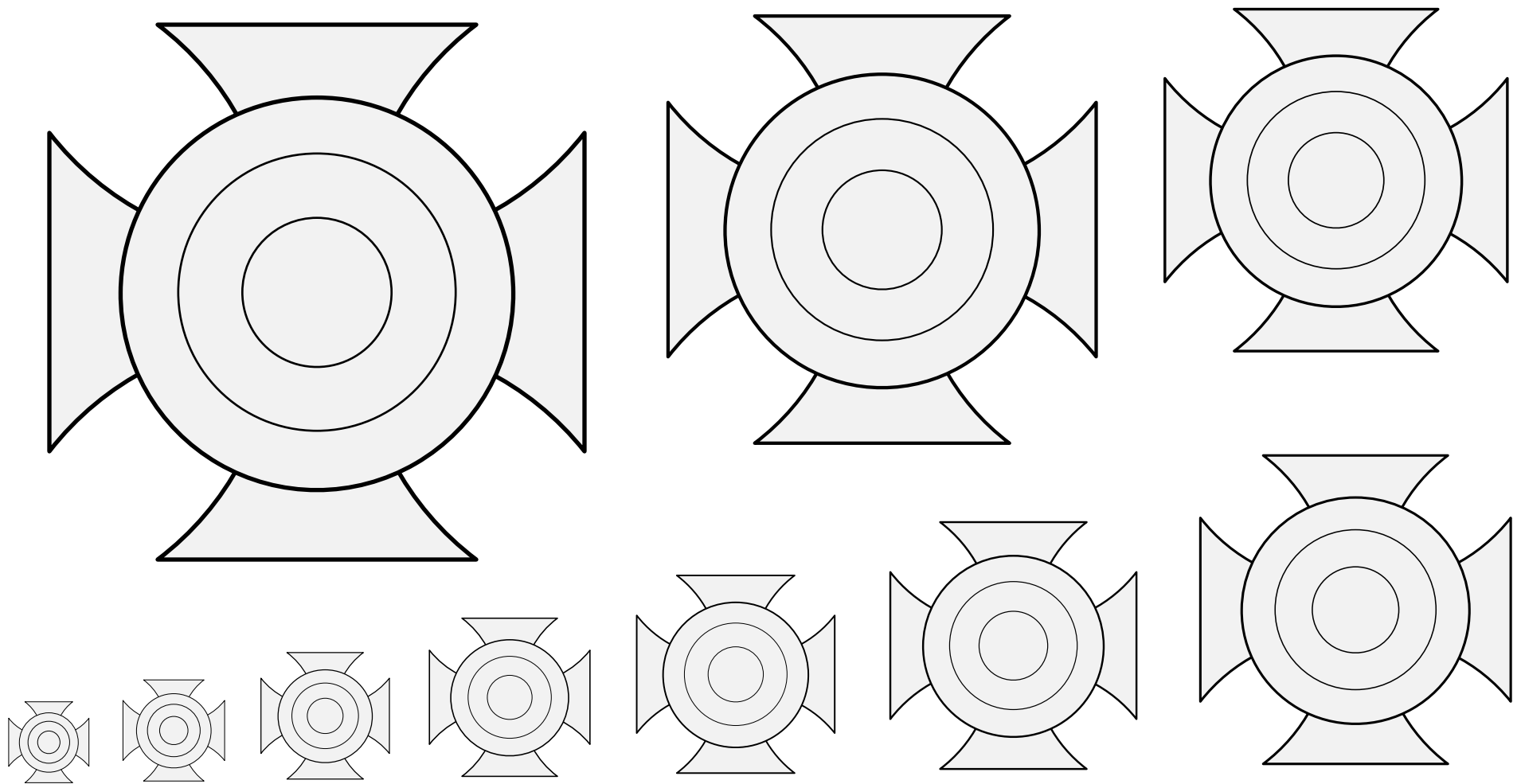

A group of stackable metal cups of carefully defined weights, with a sometimes-elaborate lid that holds them together. Used with a balance from the Roman period through the Renaissance. Found in Iberian armory where it is blazoned a "mark."
(This charge was previously misidentified as an archery target, which can also be called a mark.)

Artist: Gunnvôr silfrahárr.

Weights, Set of Nesting Scale (3) 16.143

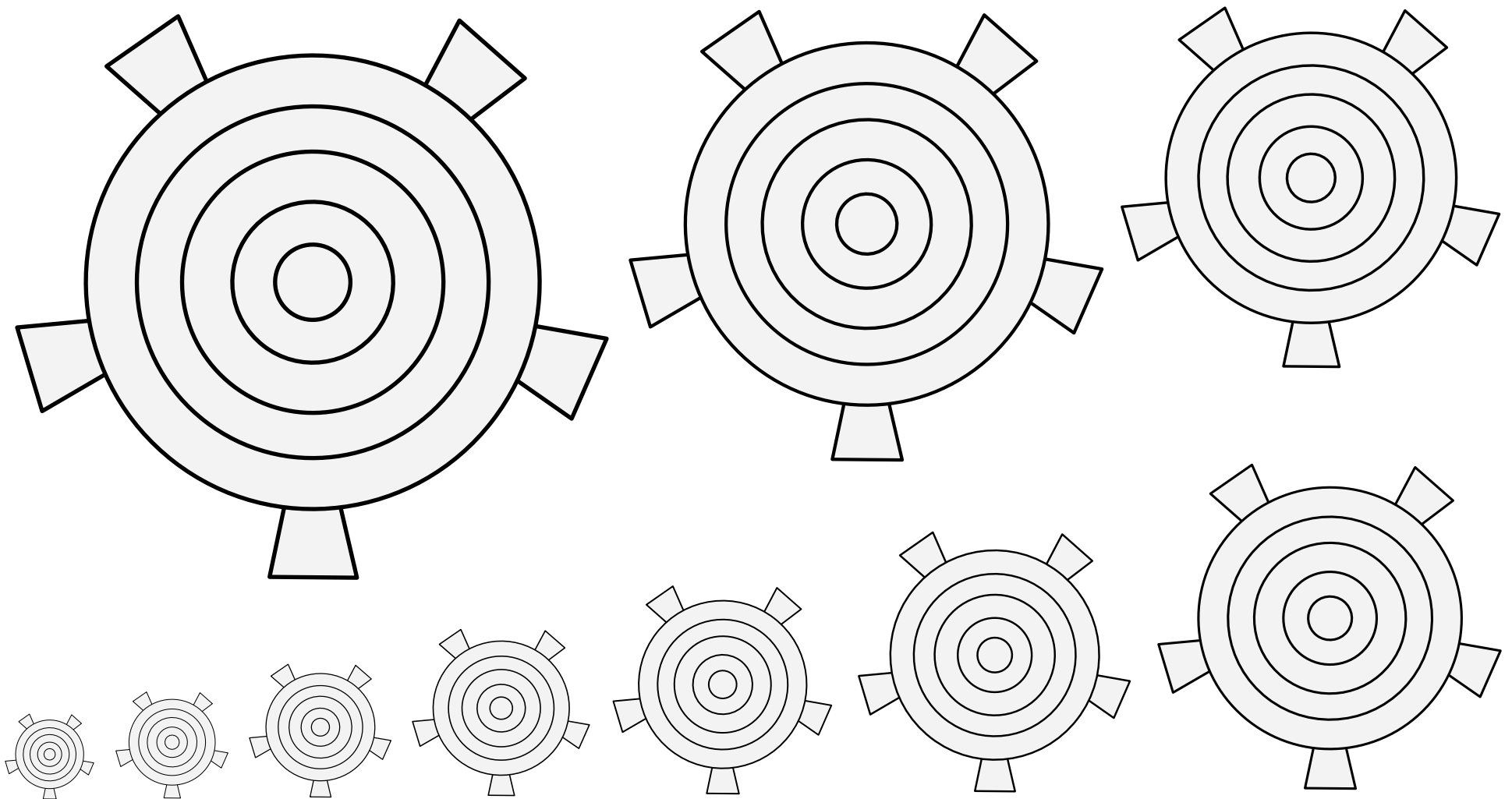

A group of stackable metal cups of carefully defined weights, with a sometimes-elaborate lid that holds them together.

Used with a balance from the Roman period through the Renaissance. Found in Iberian armory where it is blazoned a "mark."

(This charge was previously misidentified as an archery target, which can also be called a mark.)

Source: Crónica de Valencia. Artist unknown. (Folio 32v.) Adapted by Iago ab Adam.

Weights, Set of Nesting Scale (4) 16.144

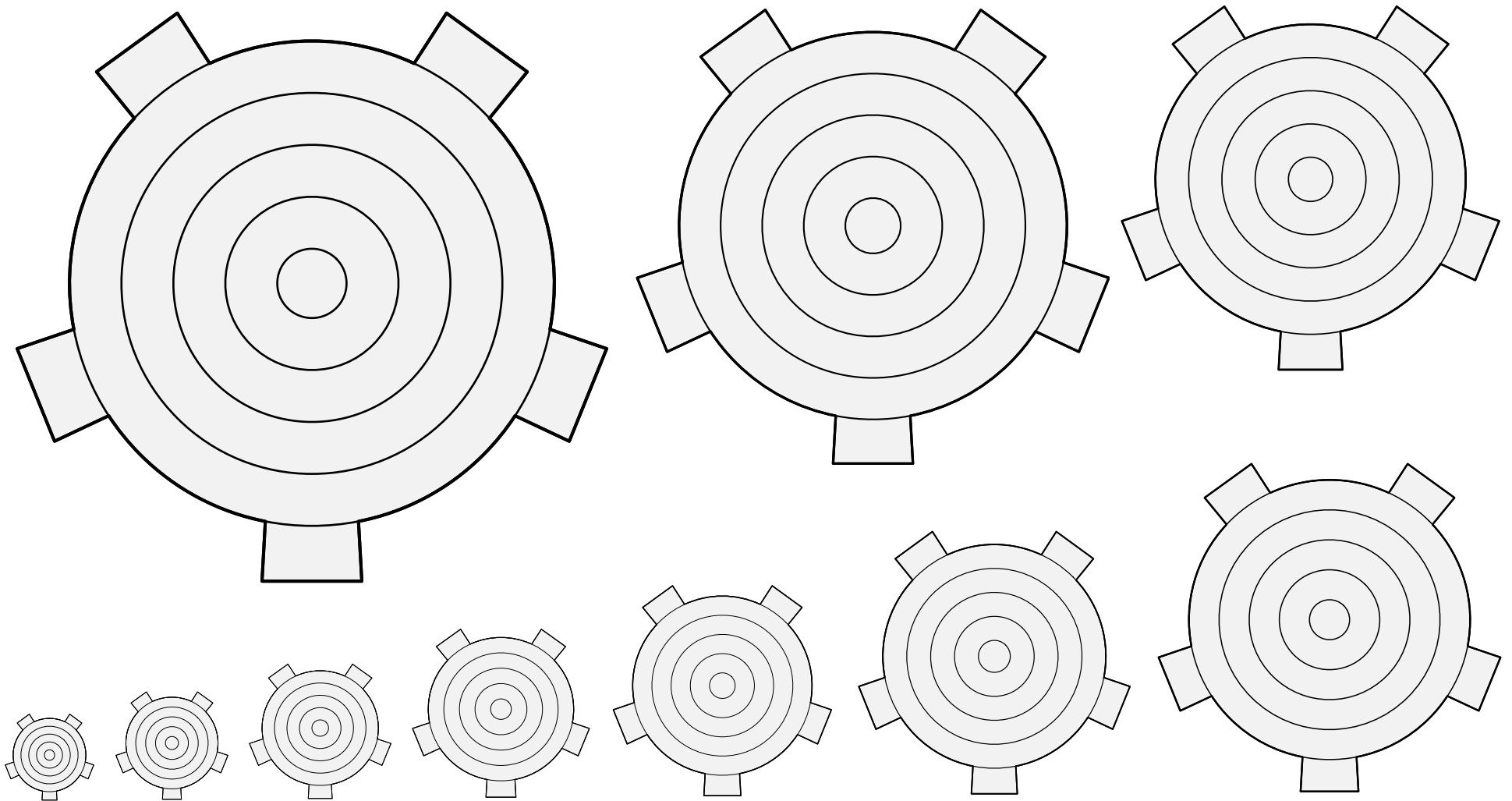

A group of stackable metal cups of carefully defined weights, with a sometimes-elaborate lid that holds them together.

Used with a balance from the Roman period through the Renaissance. Found in Iberian armory where it is blazoned a "mark."

(This charge was previously misidentified as an archery target, which can also be called a mark.)

Source: Crónica de Valencia. Artist unknown. (Folio 32v.) Adapted by Mathghamhain Ua Ruadháin.

Weights, Set of Nesting Scale (5) 16.145

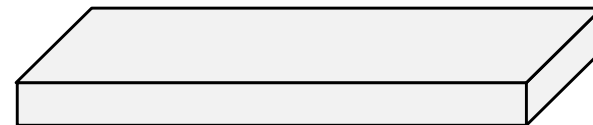
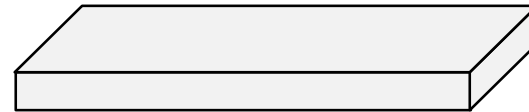
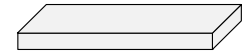
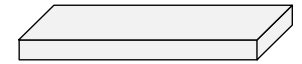
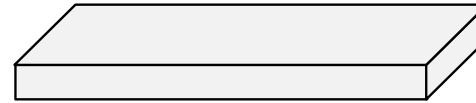
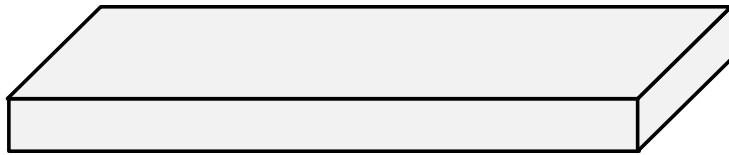
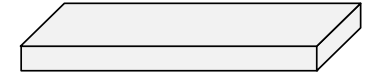
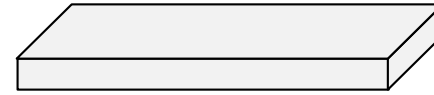

A very flat stone used for sharpening knives and similar blades.

Default orientation: fesswise. No proper coloration.

Source: Armorial Général de France. Artist unknown. (Arms of the Cutlers of Paris.)

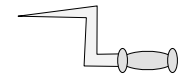
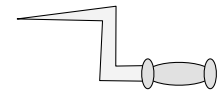
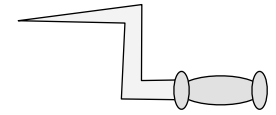
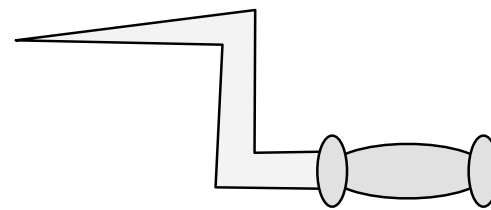
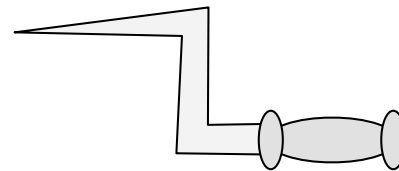
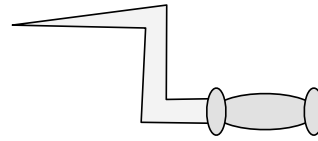
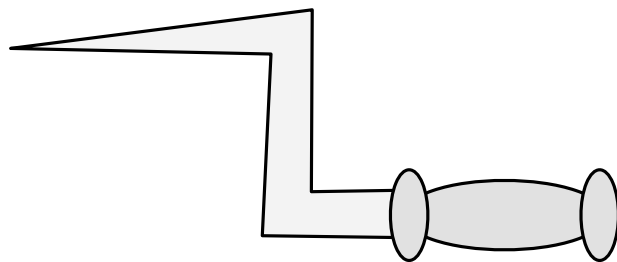
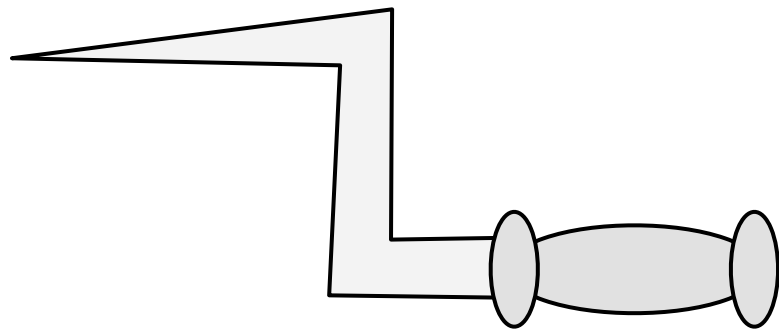

A crank handle such as might be attached to a windlass.

Default orientation: unknown. No proper coloration.

Artist: Iago ab Adam. Adapted from images of the arms of Wendling found in "Chorographia Württemberg" and "Widmung Georg Gadners an Herzog Friedrich I von Württemberg".