

❧ Book of Traceable Heraldic Art ❧

Volume 17:

Buildings

Including Furniture, Fixtures,
Castles & Other Immobile Structures

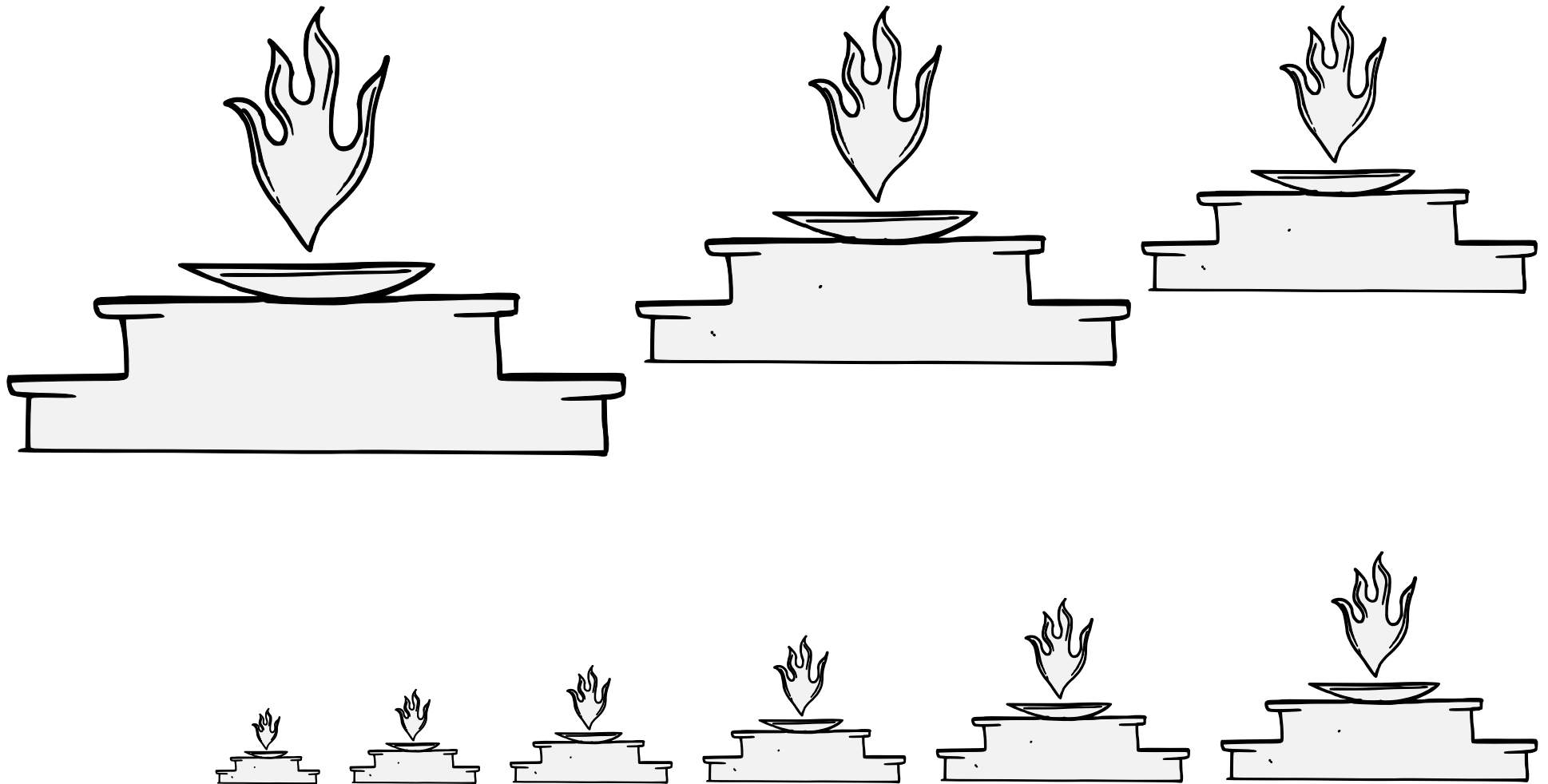

A location for religious ceremonies.

The flame may have a different tincture, blazoned "an alter *tincture* enflamed *tincture*."

Source: Pennsic Bored-Artist Collection. Artist: `Aziza al-Shiraziyya.

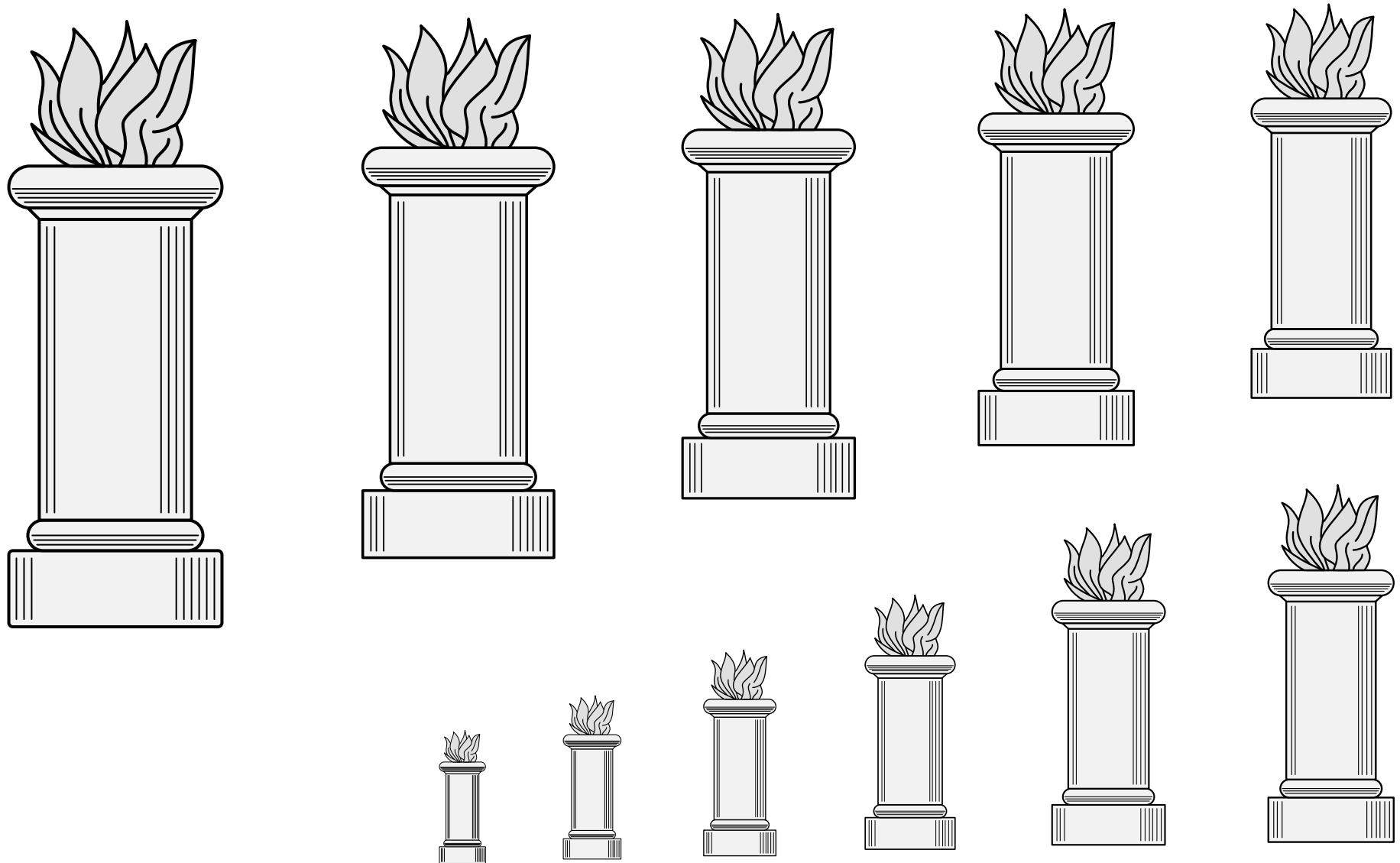

A location for religious ceremonies.

The flame may have a different tincture, blazoned “an alter *tincture* enflamed *tincture*.”

Source: A Glossary of Terms Used in Heraldry. Artist: James or Irene Parker.

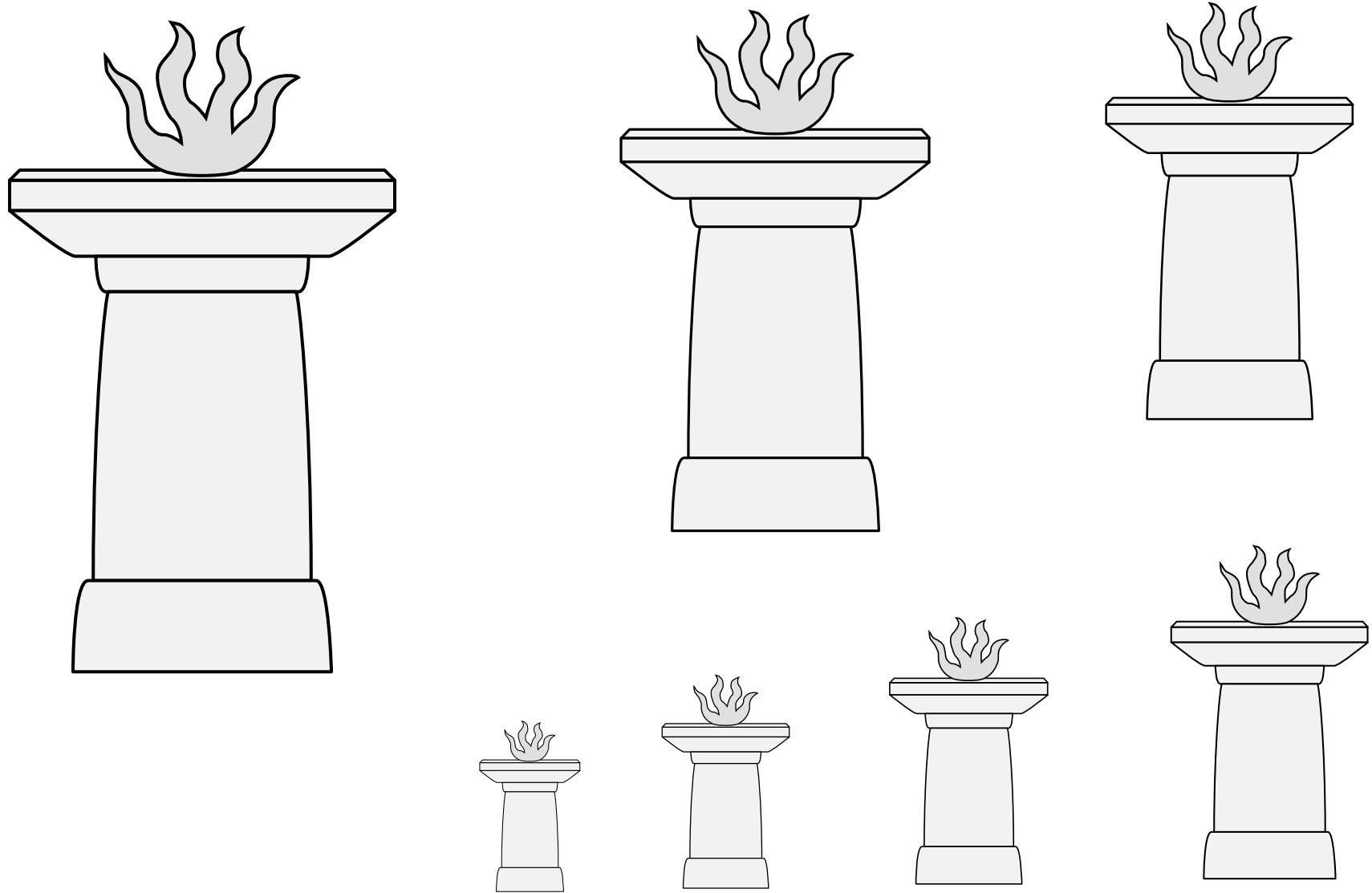

A location for religious ceremonies.

The flame may have a different tincture, blazoned “an alter *tincture* enflamed *tincture*.”

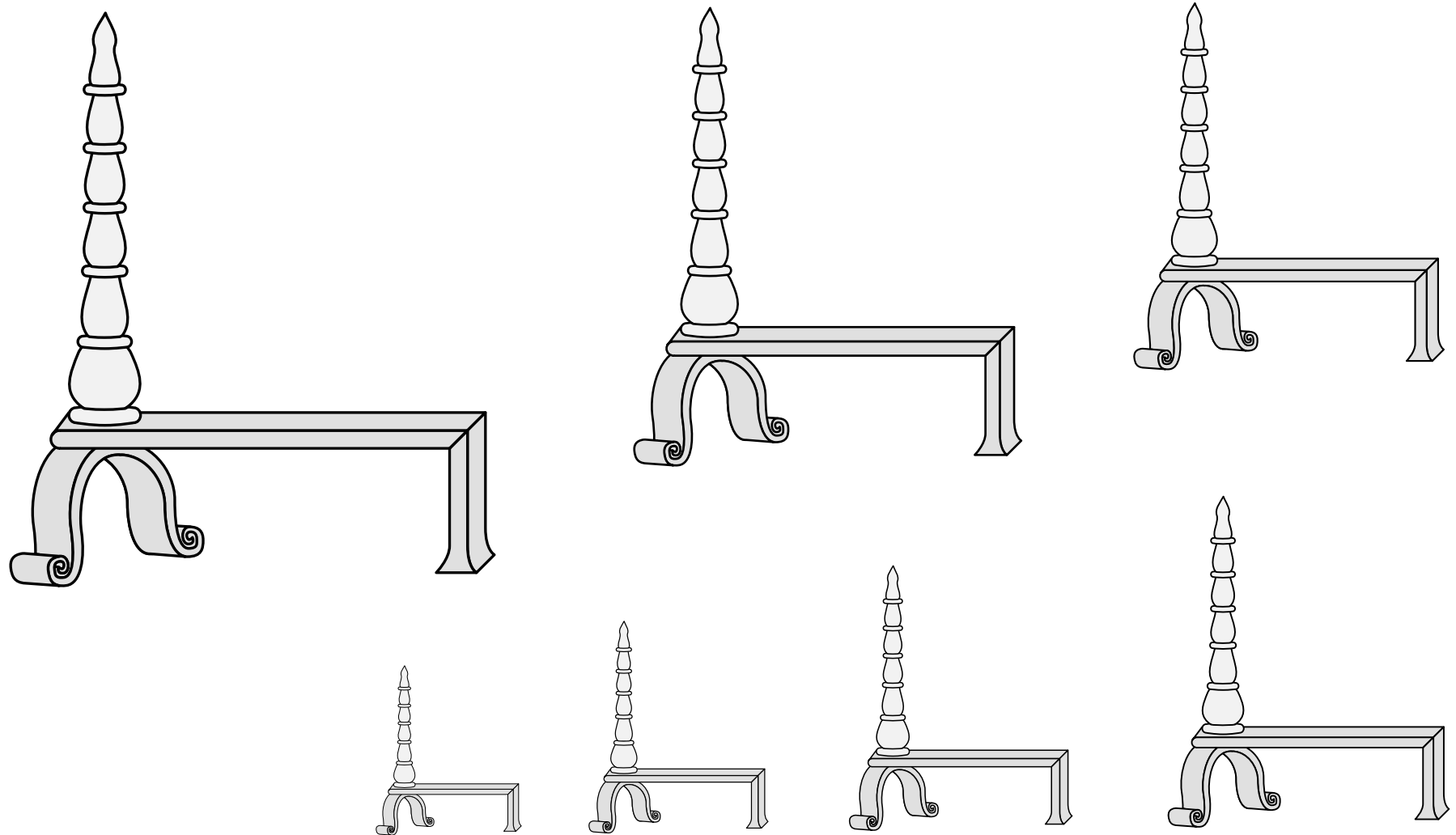

A metal structure used to hold firewood in place while it burns.

Default orientation: upright. No proper coloration.

Source: Insignia Veneta, Mantuana, Bononiensia, Anconitana, Urbiniata, Perugiensia.
Artist unknown. (Page 105.)

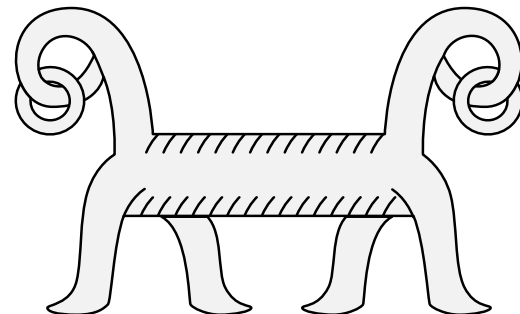
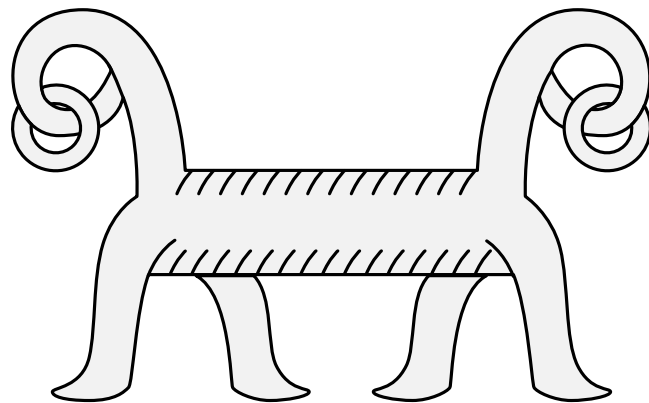
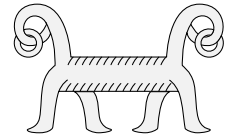
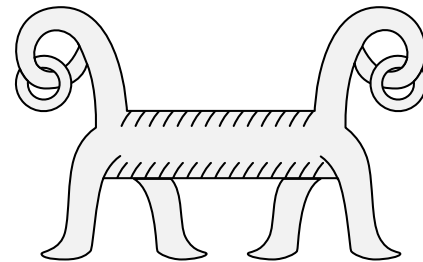
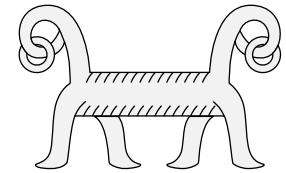
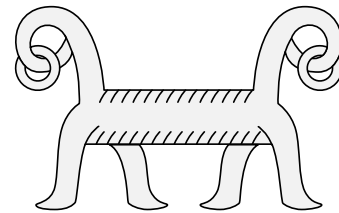
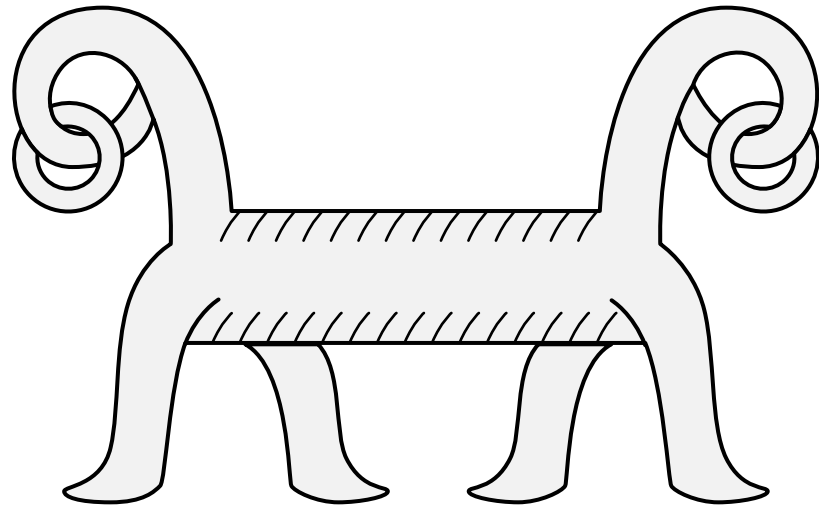

A metal structure used to hold firewood in place while it burns.

Default orientation: upright. No proper coloration.

Source: BSB Cgm 8030. Artist unknown. (Folio 176r.)

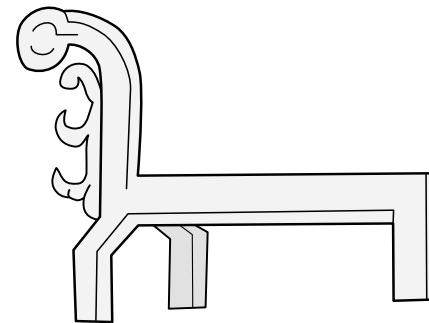
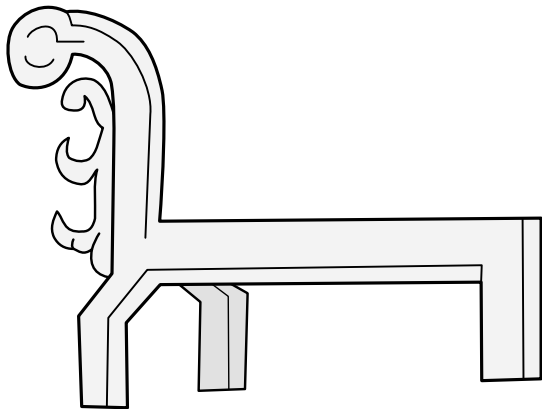
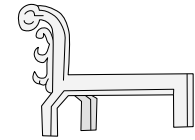
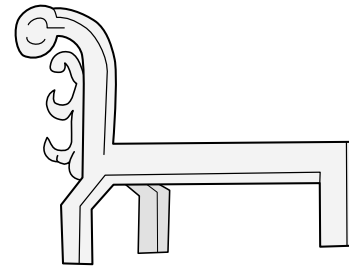
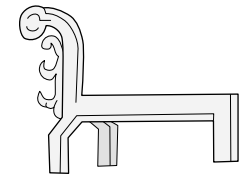
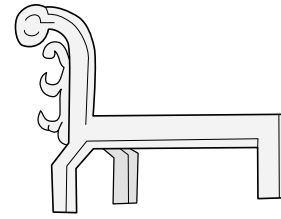
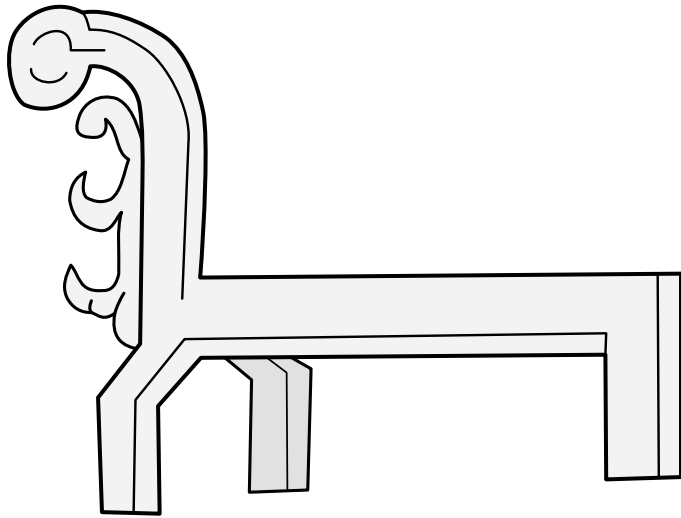

A metal structure used to hold firewood in place while it burns.

Default orientation: upright. No proper coloration.

Source: A Display of Heraldry. Artist: John Guillim.
(Manuscript folio 101r.) Adapted by Iago ab Adam.

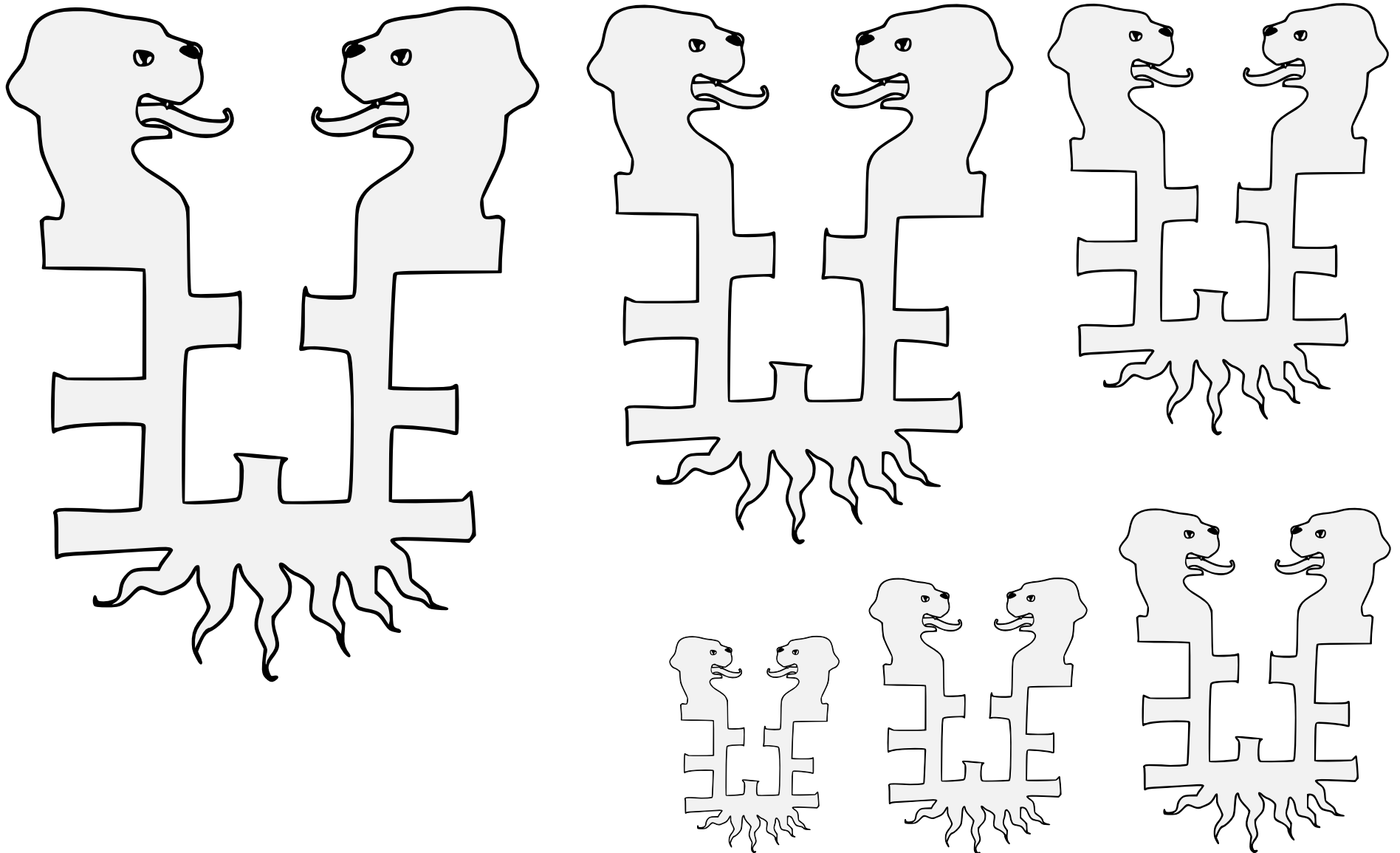

A metal structure used to hold firewood in place while it burns.

Default orientation: upright. No proper coloration.

Source: Sammelband Mehrerer Wappenbücher.
Artist unknown. (Folio 30.)

Andirons, Pair of Dog-Headed 17.8

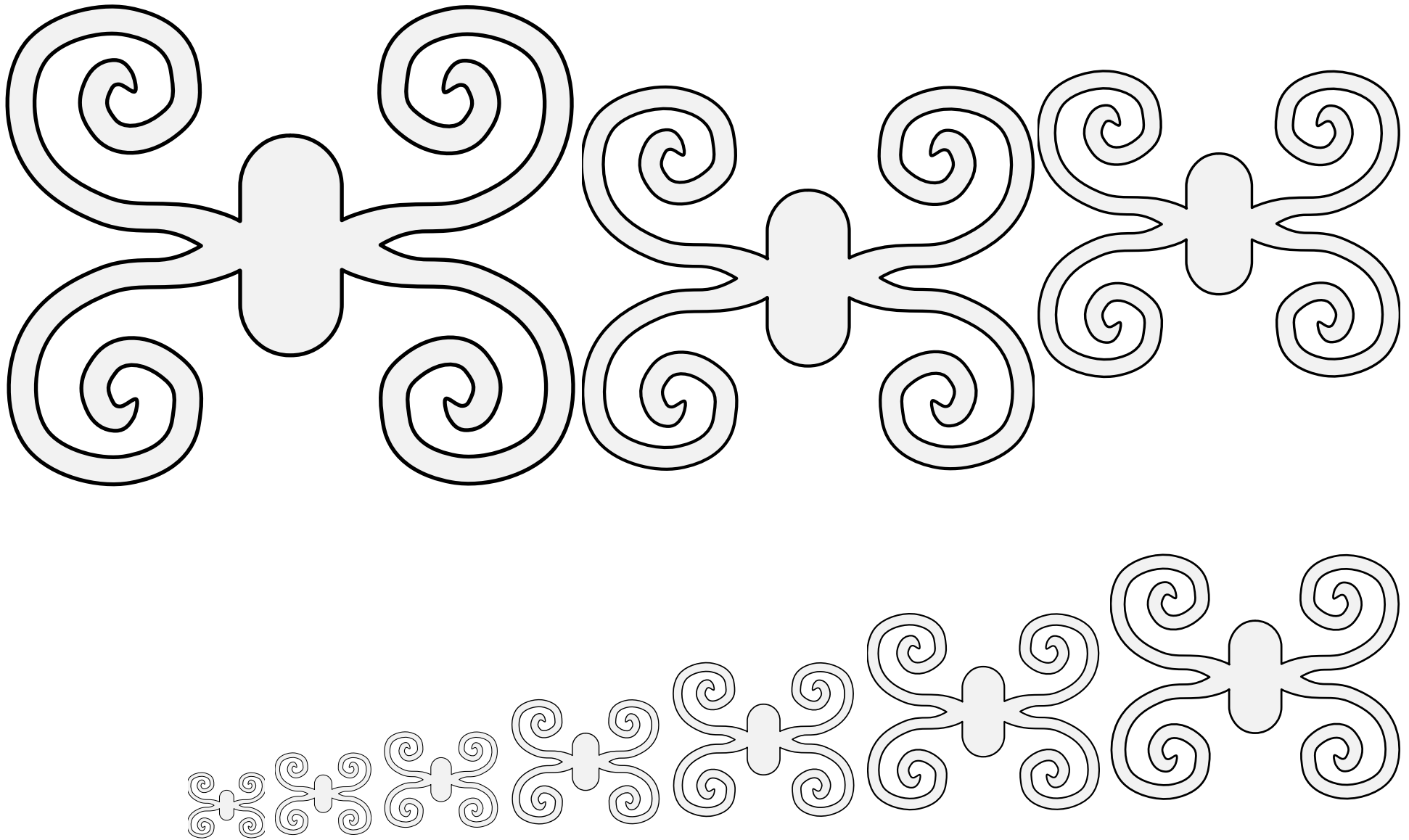

A wall anchor plate, used to fasten pieces of a building together.

Default orientation: fesswise. No proper coloration.

Source: Armorial de Gelre. Artist: Claes Heinenzoon. (Arms of Breidenbach.)

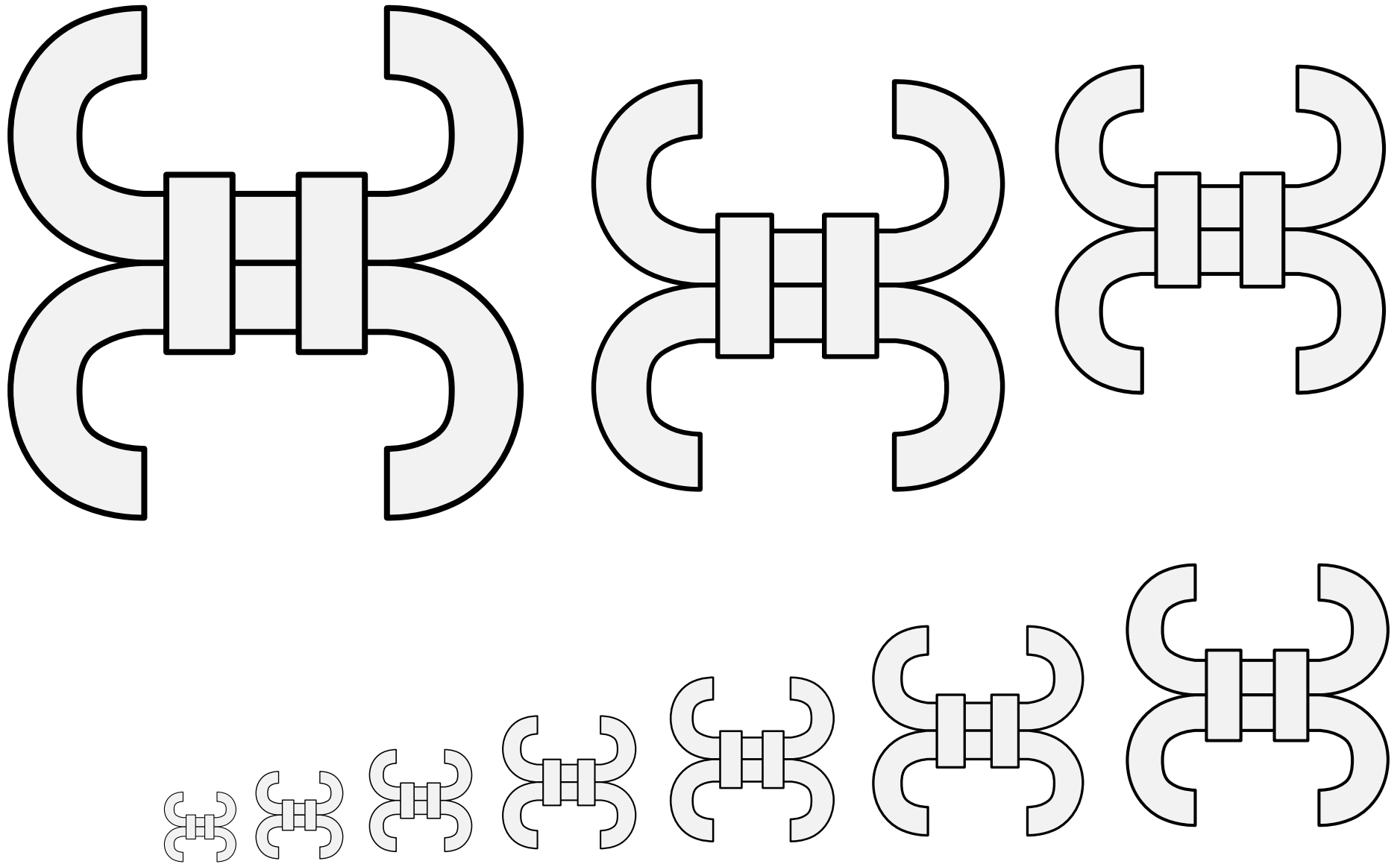

A wall anchor plate, used to fasten pieces of a building together.

Default orientation: fesswise. No proper coloration.

Source: Wikimedia Commons. Artist: F.rodriigo. License: Public domain.

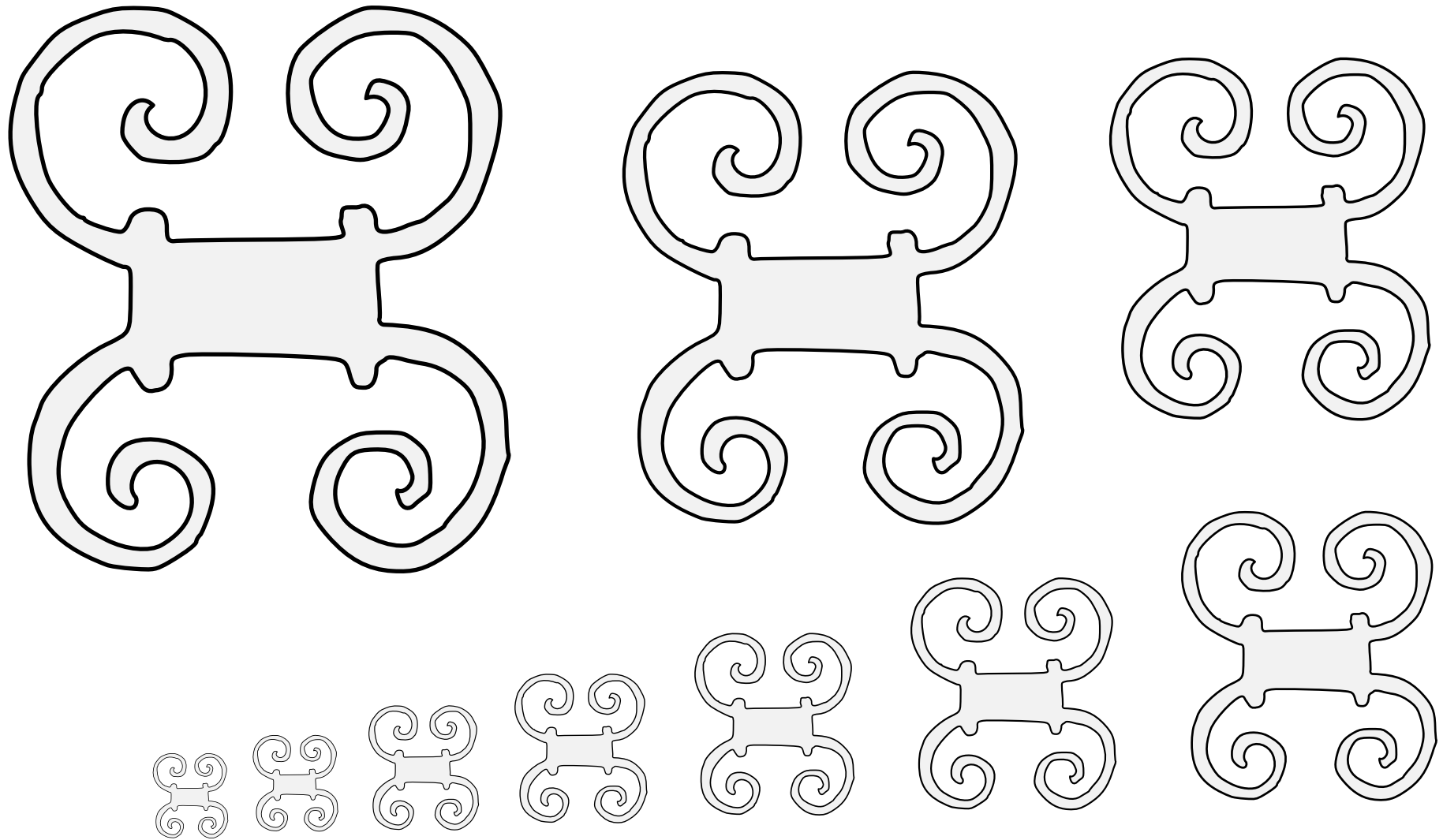

A wall anchor plate, used to fasten pieces of a building together.

Default orientation: fesswise. No proper coloration.

Source: Wappenbuch der Arlberg-Bruderschaft. Artist: Vigil Raber.

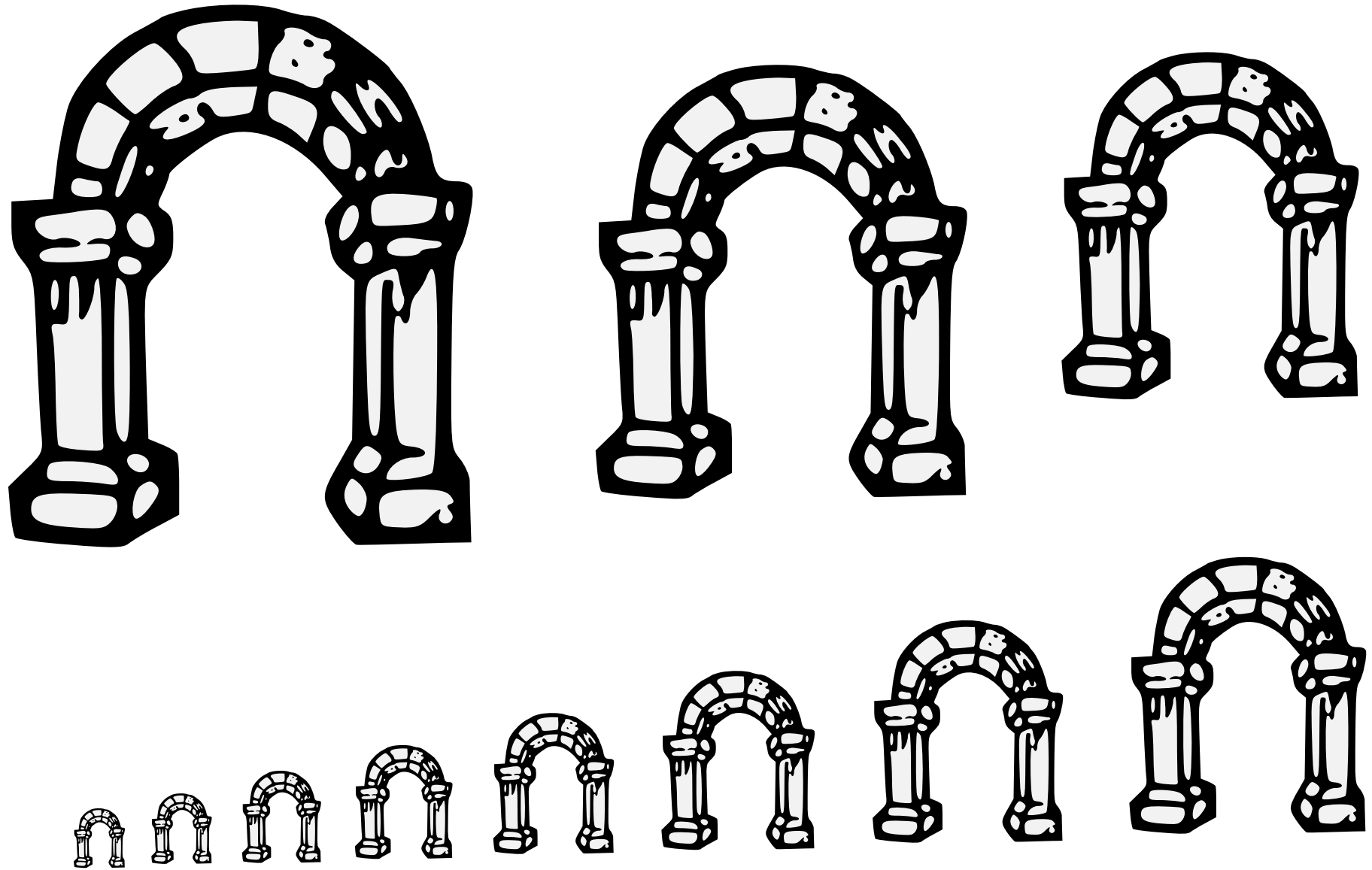

A entryway framed in stone.

Default orientation: upright. Proper coloration: only if material is blazoned; a stone item is argent.

Source: Guillim's Display of Heraldry. Artist unknown.

Arch (1) 17.12

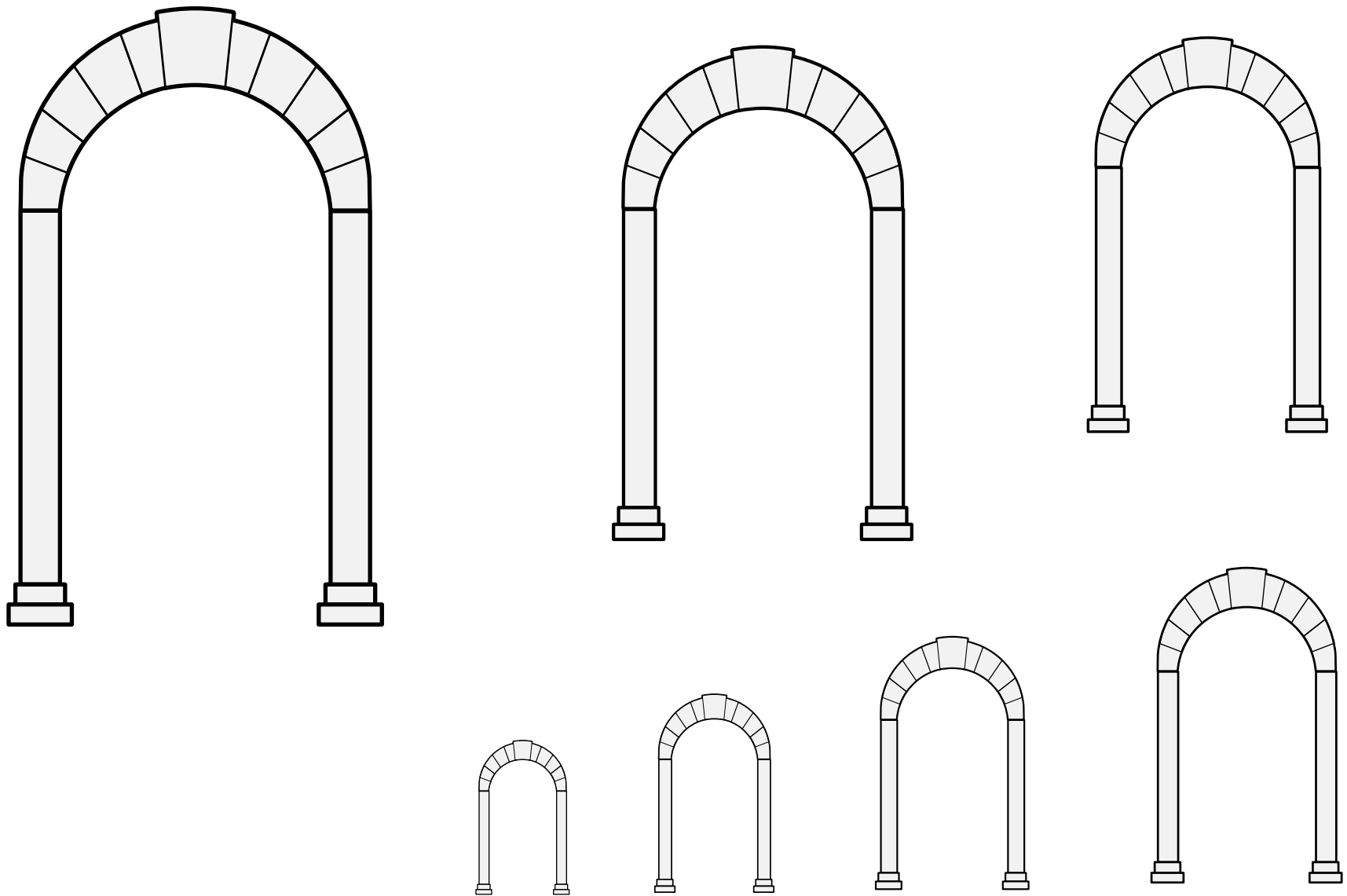

A entryway framed in stone.

Default orientation: upright. Proper coloration: only if material is blazoned; a stone item is argent.

Source: Viking Answer Lady SVG Images For Heraldists. Artist: Gunnvör silfrhárr.

Adapted by Mathghamhain Ua Ruadháin.

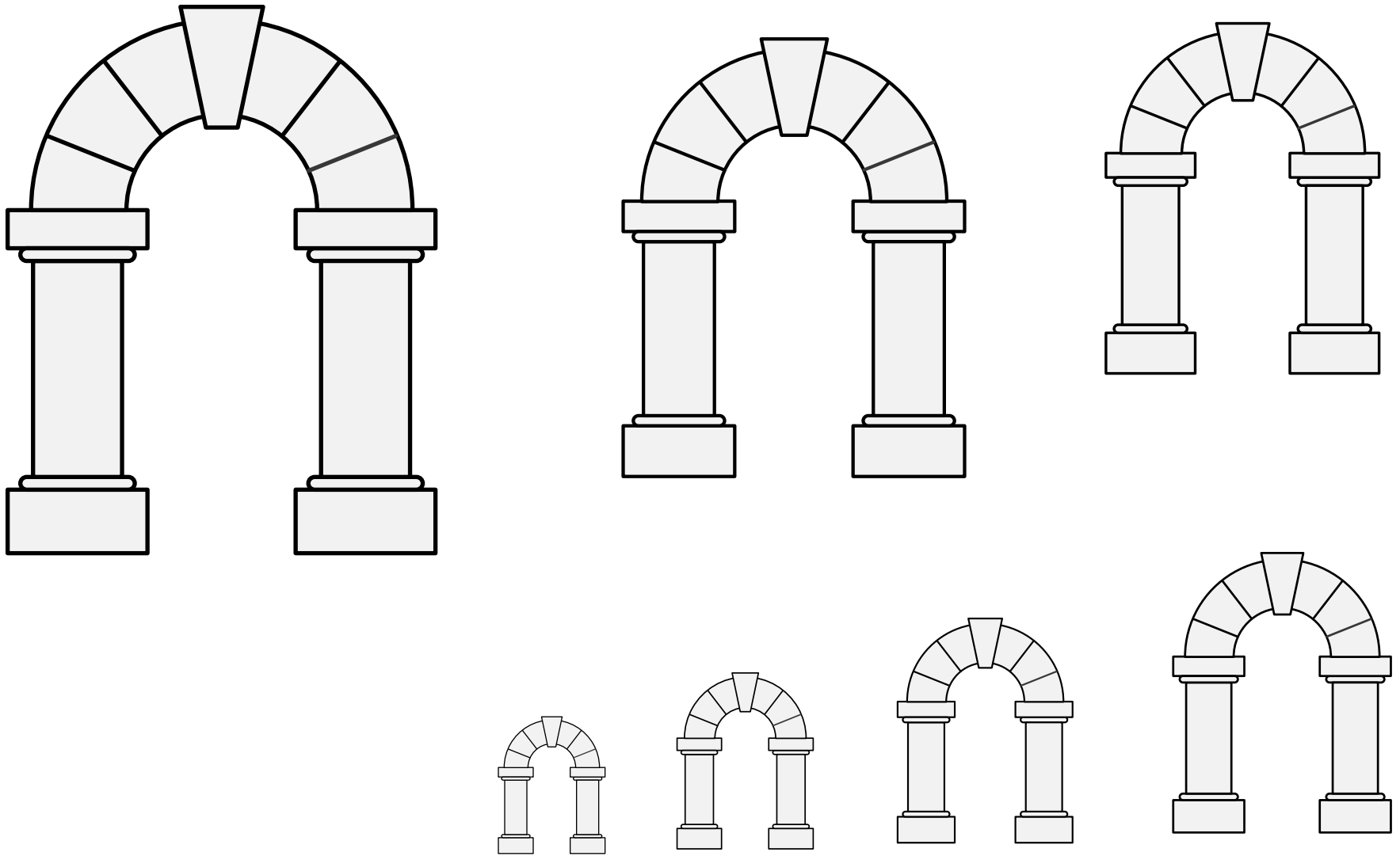

A entryway framed in stone.

Default orientation: upright. Proper coloration: only if material is blazoned; a stone item is argent.

Adapted from a depiction of the arms of Sir Richard Arches in a stained-glass panel in Bampton Church, Devon.

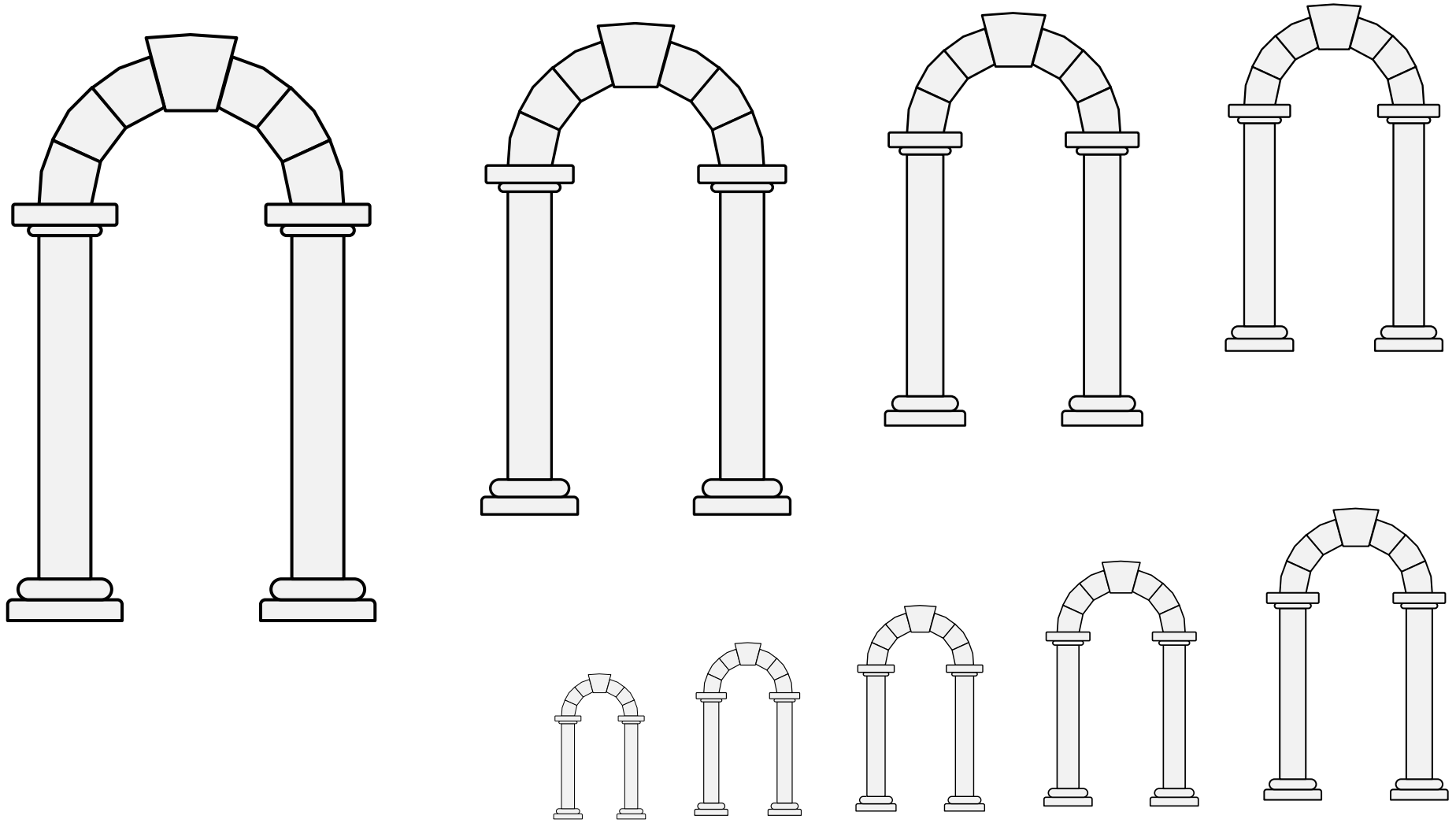

A entryway framed in stone.

Default orientation: upright. Proper coloration: only if material is blazoned; a stone item is argent.

Source: A Glossary of Terms Used in Heraldry. Artist: James or Irene Parker.

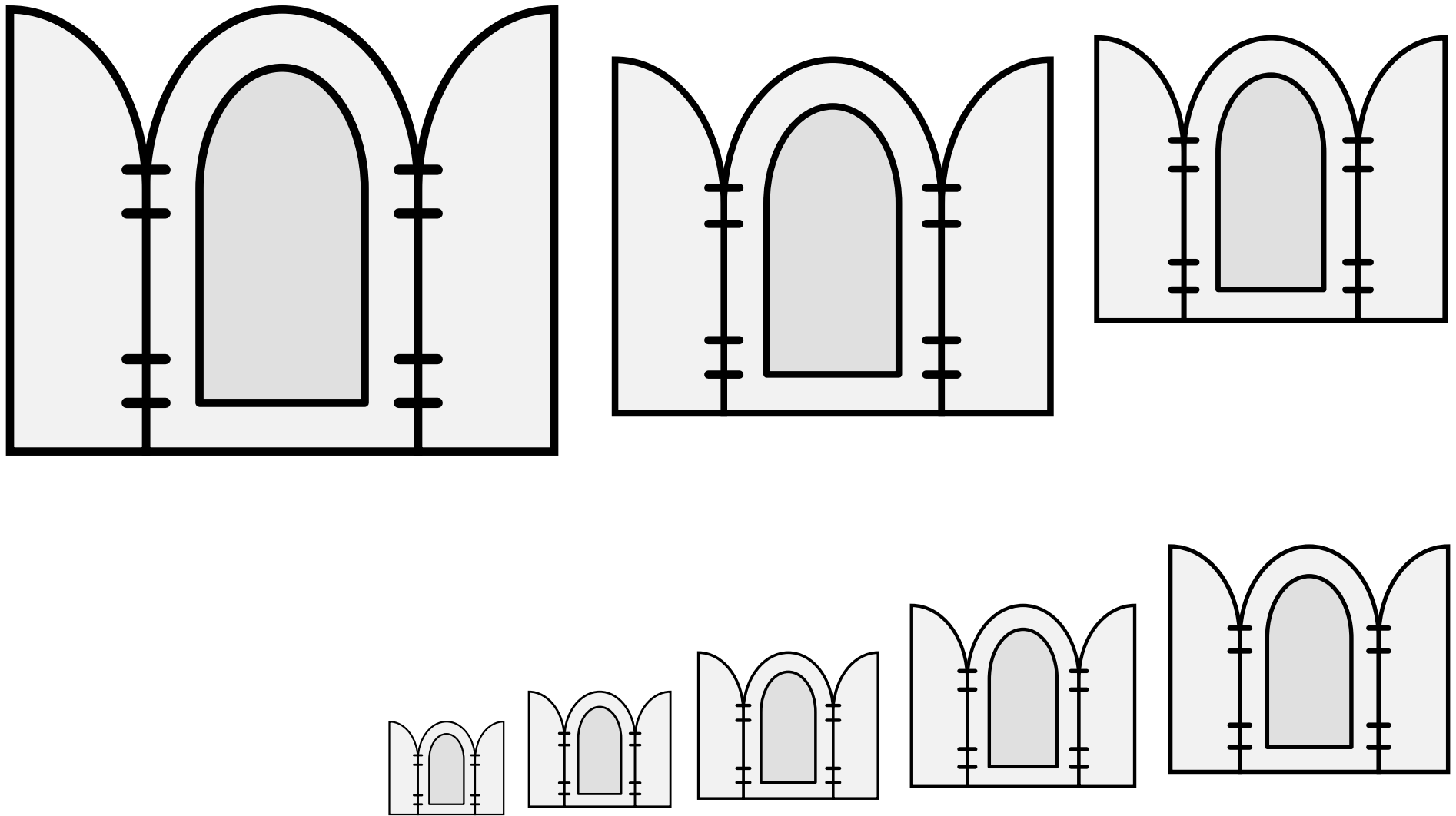

A entryway framed in stone.

Default orientation: upright. Proper coloration: only if material is blazoned; a stone item is argent, a wooden item is brown. The opening of the doorway may the same tincture, or a blazoned tincture, or of the field.

Source: Zurich Roll. Artist unknown.
Adapted by Mathghamhain Ua Ruadháin.

Arch with Open Doors (1) 17.16

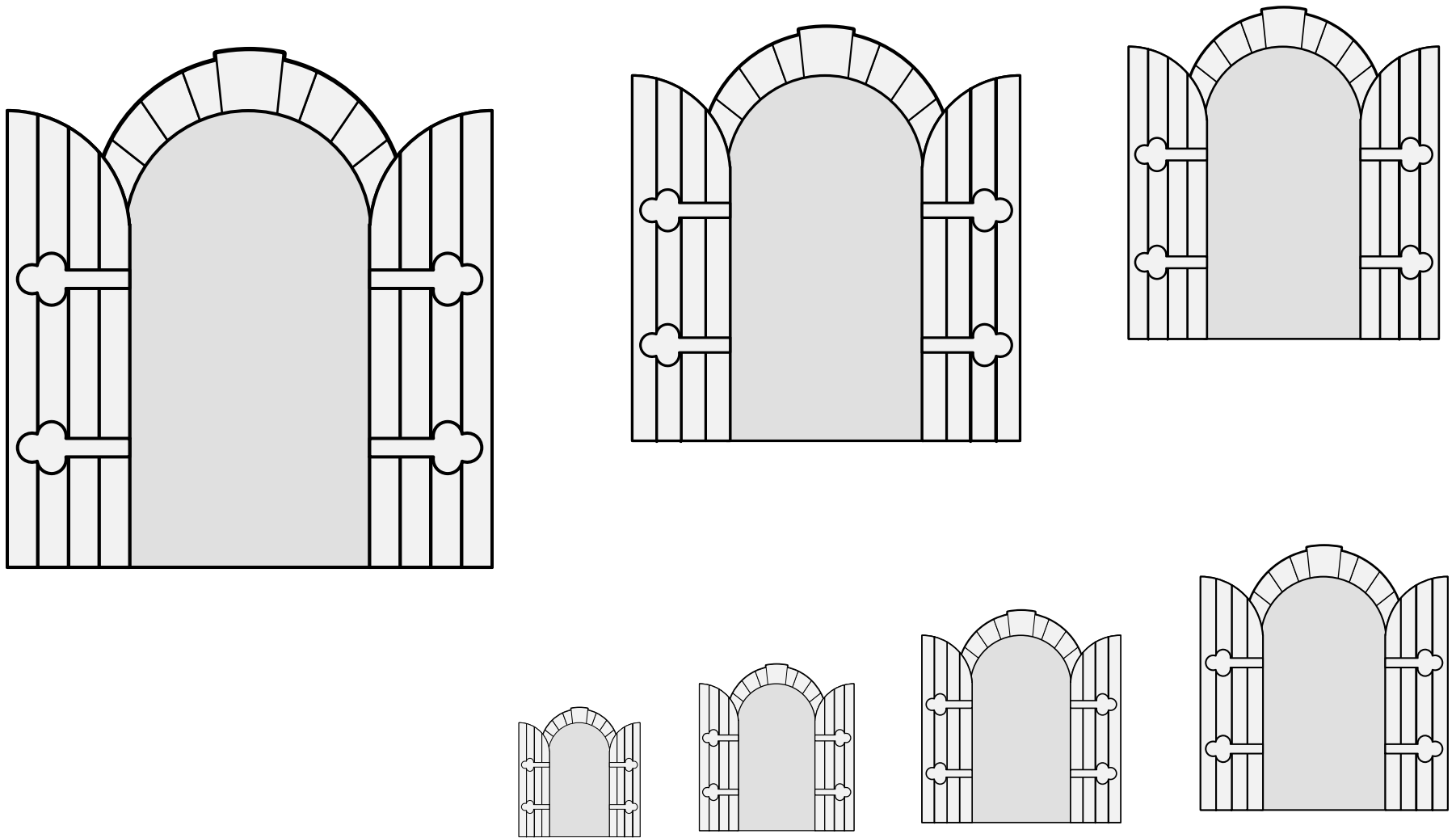

A entryway framed in stone.

Default orientation: upright. Proper coloration: only if material is blazoned; a stone item is argent, a wooden item is brown.

The opening of the doorway may the same tincture, or a blazoned tincture, or of the field.

Source: Viking Answer Lady SVG Images For Heraldry.

Artist: Gunnvör silfrhárr.

Adapted by Mathghamhain Ua Ruadháin.

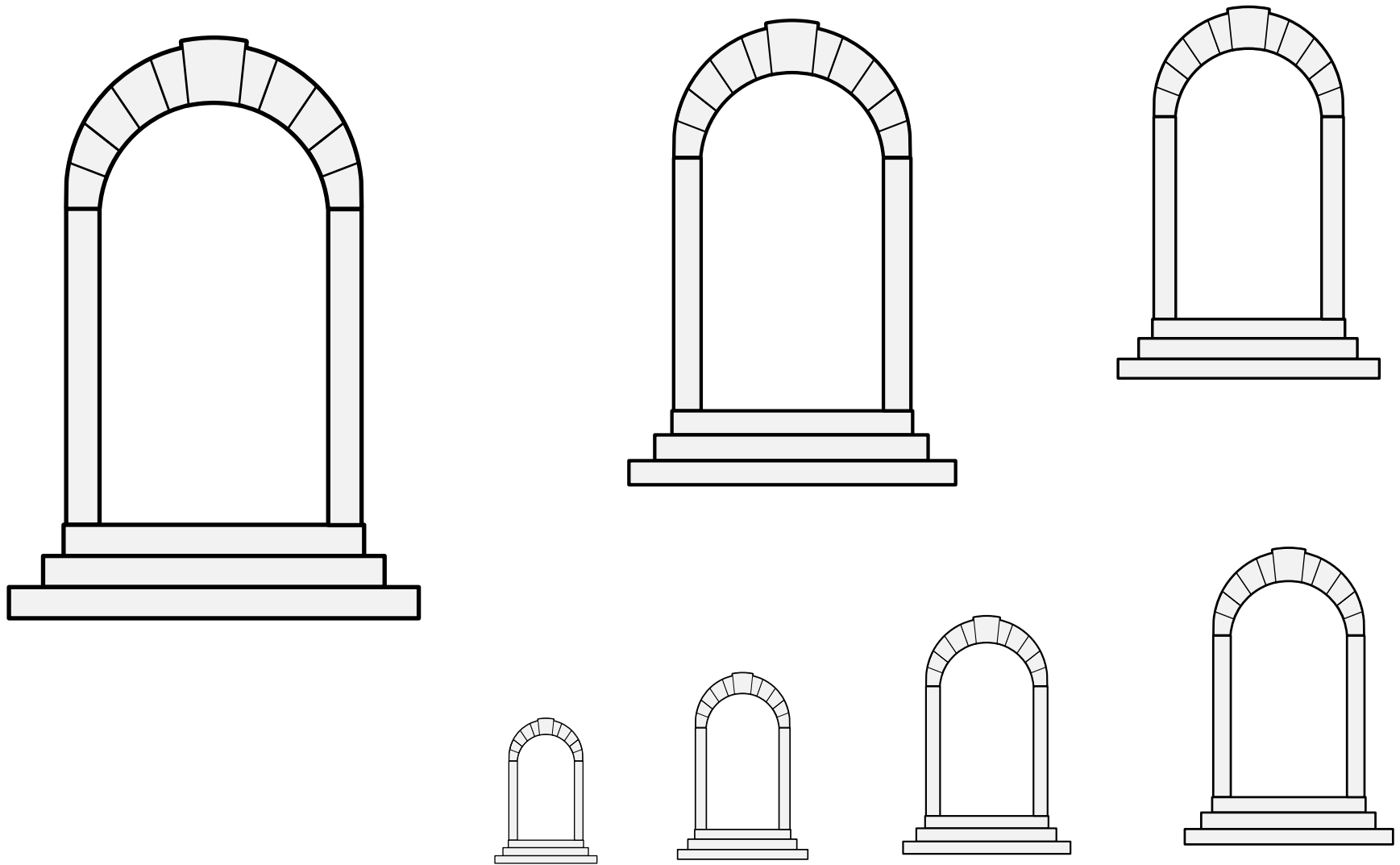

A entryway framed in stone.

Default orientation: upright. Proper coloration: only if material is blazoned; a stone item is argent.

Source: Viking Answer Lady SVG Images For Heraldry. Artist: Gunnvör silfrhárr.
Adapted by Mathghamhain Ua Ruadháin.

Arch Stooped 17.18

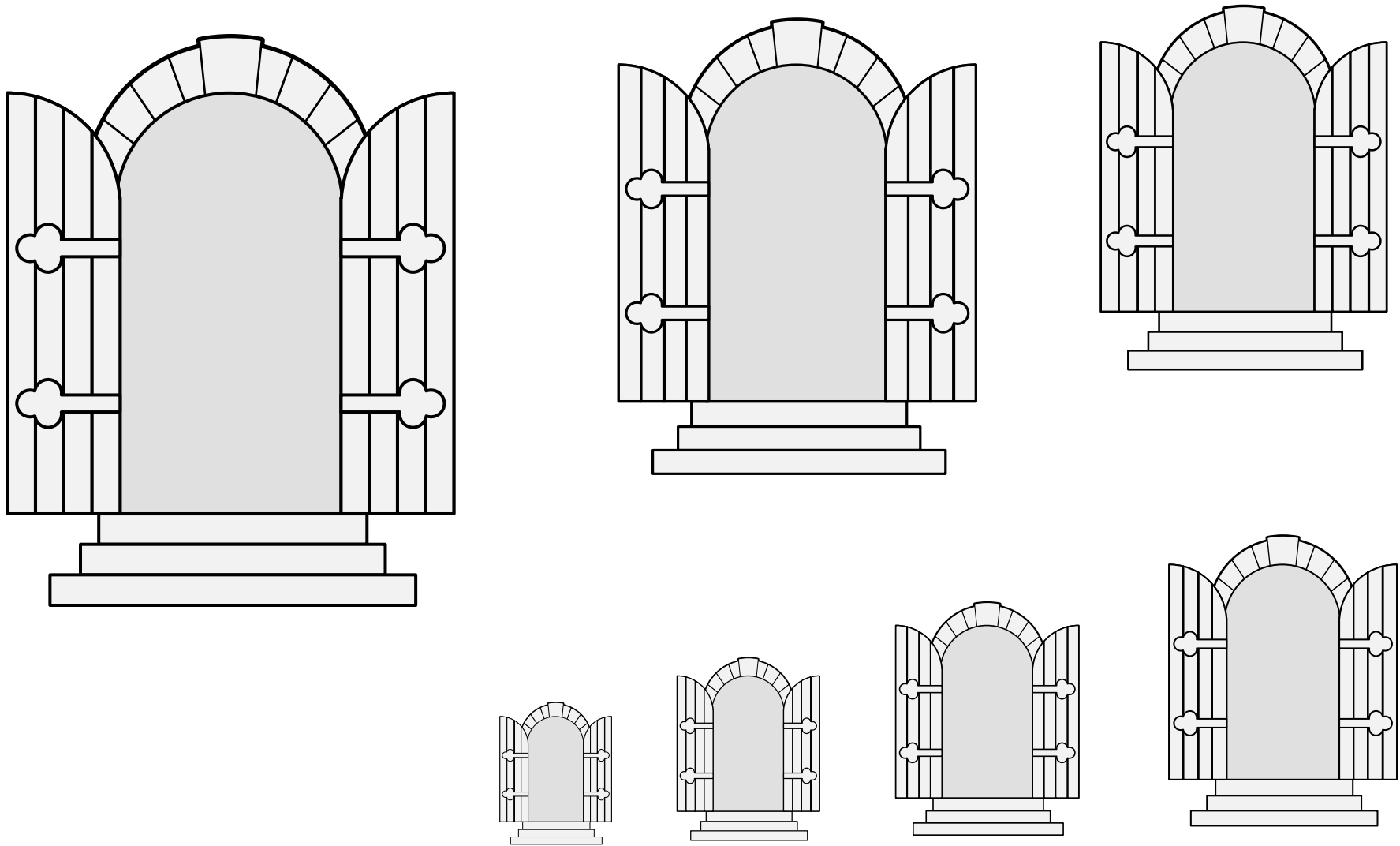

A entryway framed in stone.

Default orientation: upright. Proper coloration: only if material is blazoned; a stone item is argent, a wooden item is brown.
The opening of the doorway may the same tincture, or a blazoned tincture, or of the field.

Source: Viking Answer Lady SVG Images
For Heralds. Artist: Gunnvôr silfrahárr.

Arch Stooped with Open Doors (1) 17.19

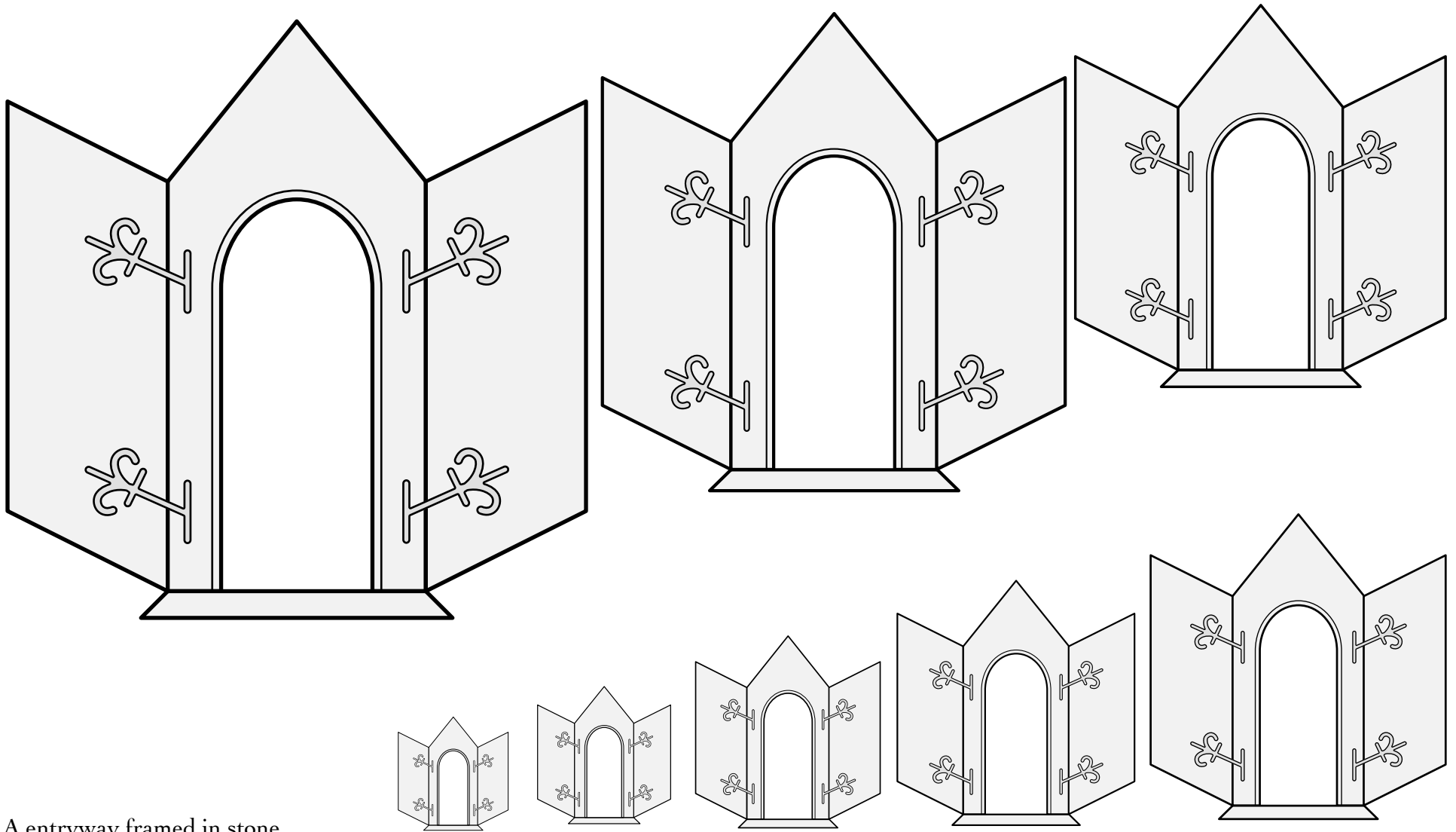

A entryway framed in stone.

Default orientation: upright. Proper coloration: only if material is blazoned; a stone item is argent, a wooden item is brown.

The opening of the doorway may the same tincture, or a blazoned tincture, or of the field.

Source: Le Grand Armorial Équestre de la Toison d'Or. Artist unknown. Adapted by Mathghamhain Ua Ruadháin. (Page 18.)

Arch Stooped with Open Doors (2) 17.20

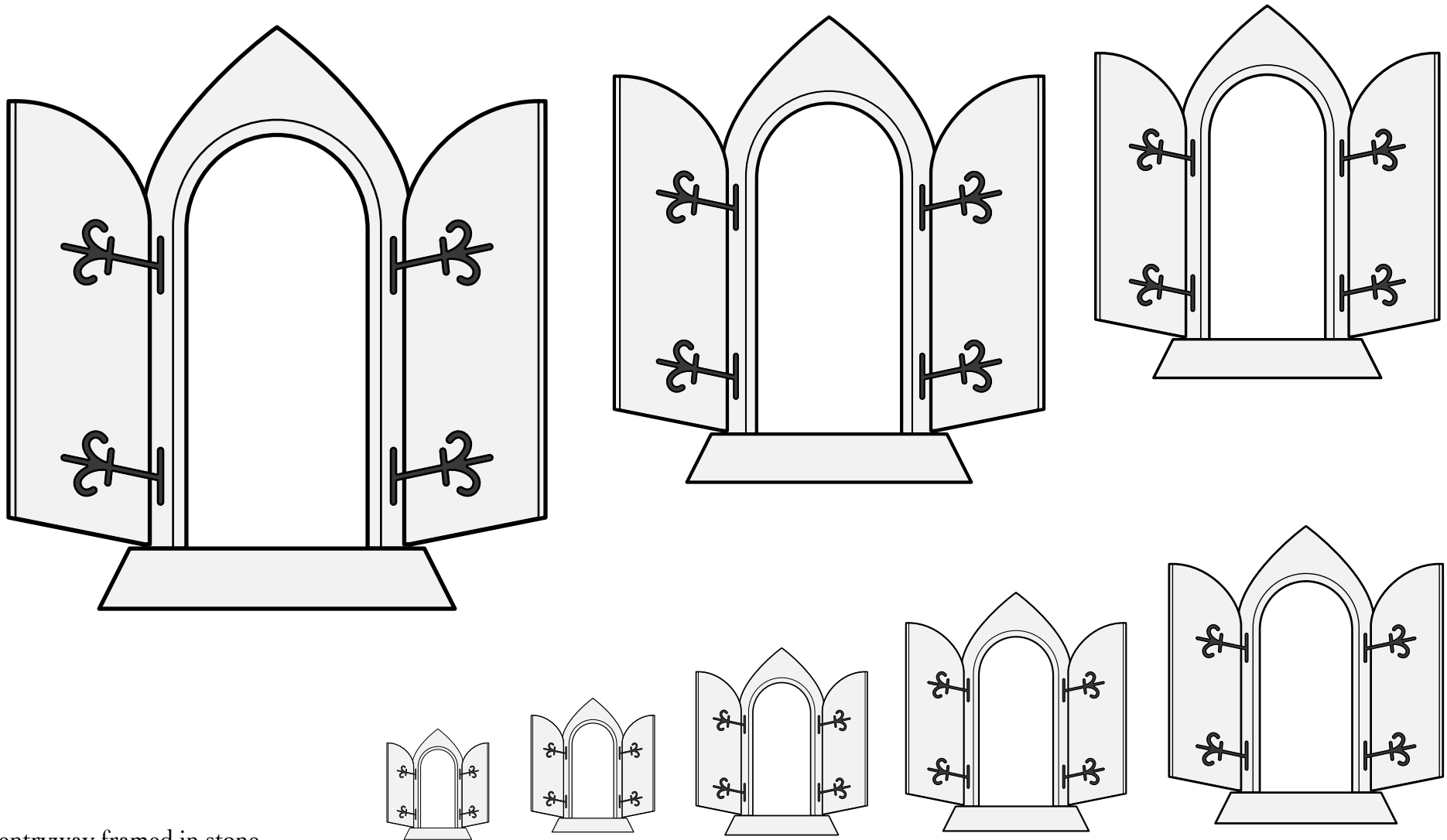

A entryway framed in stone.

Default orientation: upright. Proper coloration: only if material is blazoned; a stone item is argent, a wooden item is brown.

The opening of the doorway may the same tincture, or a blazoned tincture, or of the field.

Source: Le Grand Armorial Équestre de la Toison d'Or. Artist unknown. Adapted by Mathghamhain Ua Ruadháin. (Page 18.)

Arch Stooped with Open Doors (3) 17.21

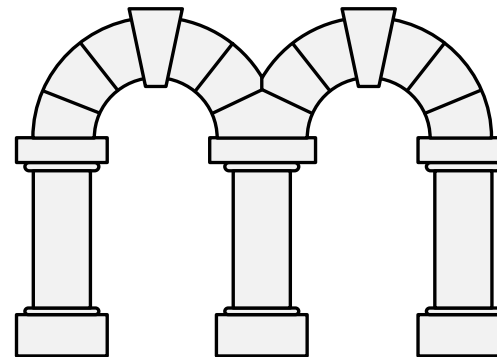
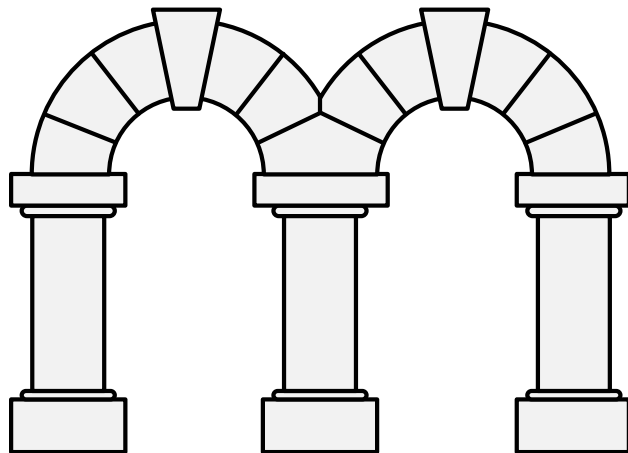
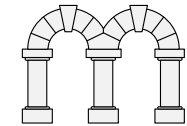
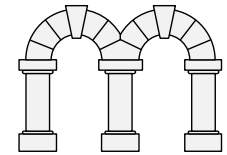
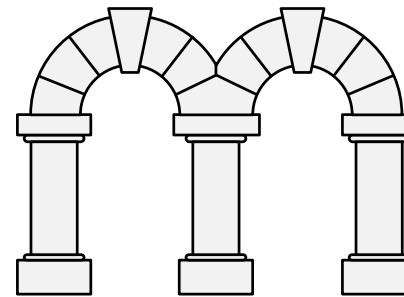
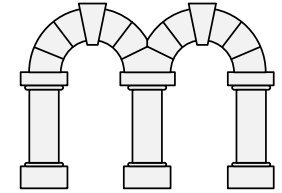
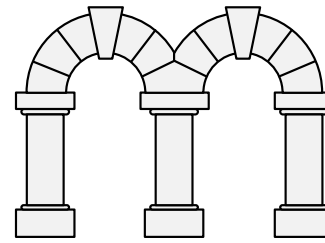
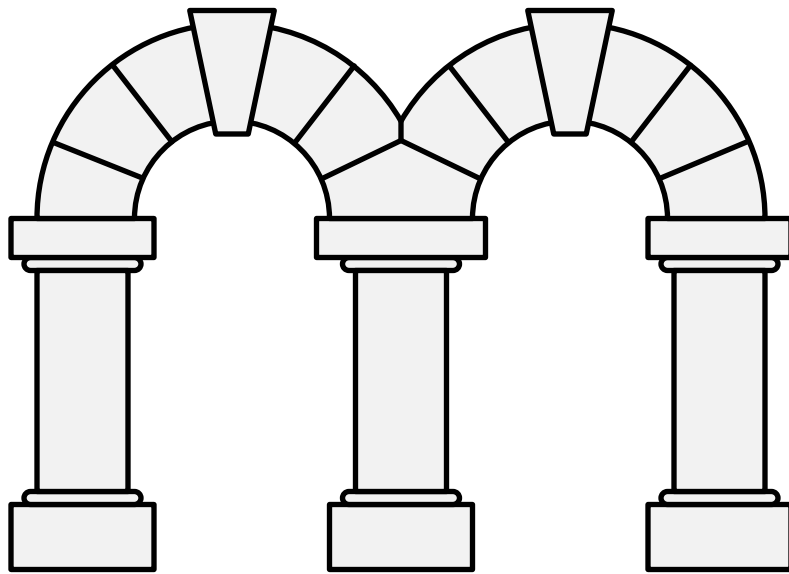

A entryway framed in stone.

Default orientation: upright. Proper coloration: argent stone.

Adapted from a depiction of the arms of Sir Richard Arches in a stained-glass panel in Bampton Church, Devon.

Arches, Pair of (1) 17.22

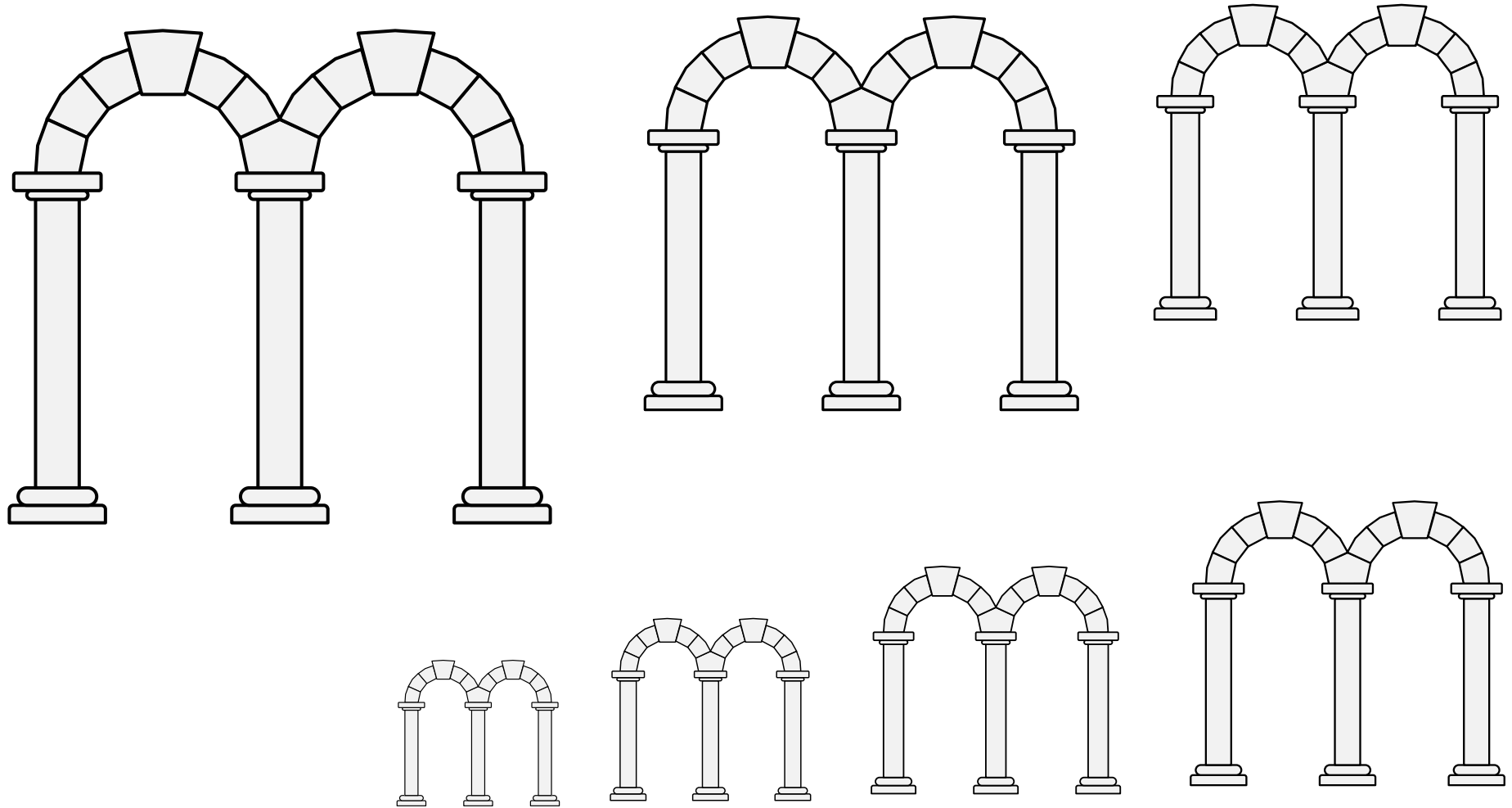

A entryway framed in stone.

Default orientation: upright. Proper coloration: argent stone.

Source: A Glossary of Terms Used in Heraldry. Artist: James or Irene Parker.

Arches, Pair of (2) 17.23

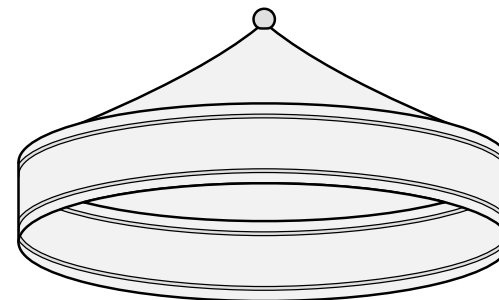
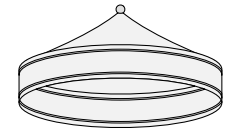
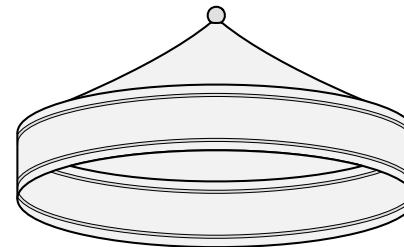
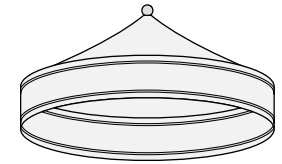
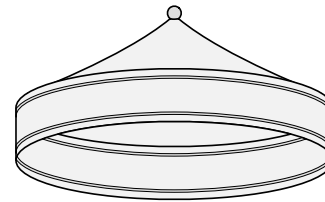
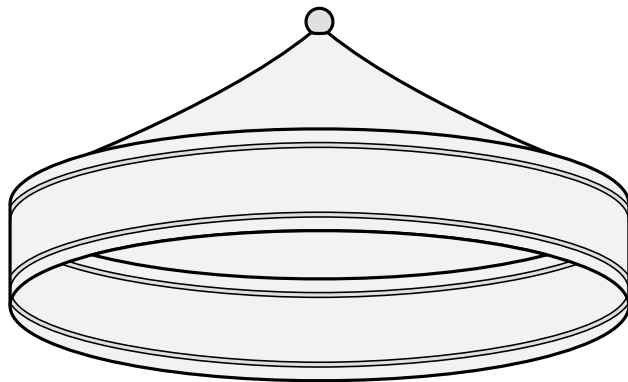
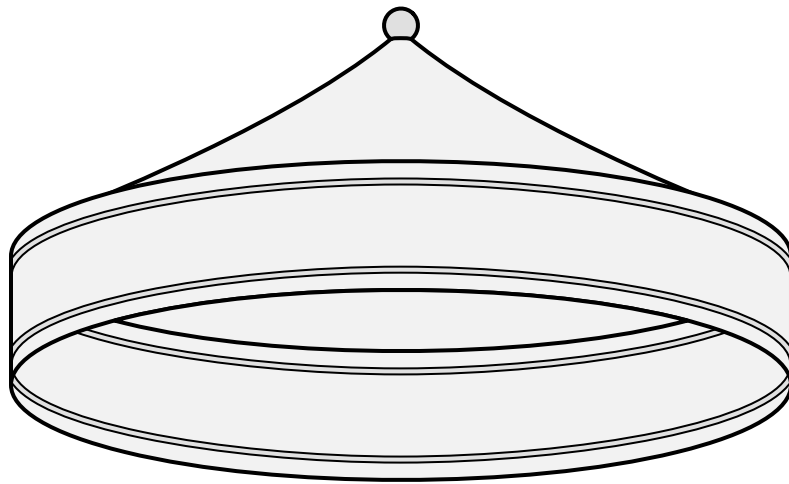

A hanging canopy, as might appear over a throne or altar.

Default orientation: point to chief. No proper coloration.

Source: Book of Hours, Morgan MS M.1114. (Folio 11r.)
Artist unknown. Adapted by Mathghamhain Ua Ruadháin.

Baldaqin, Circular (1) 17.24

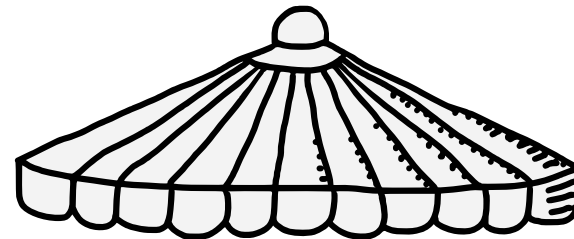
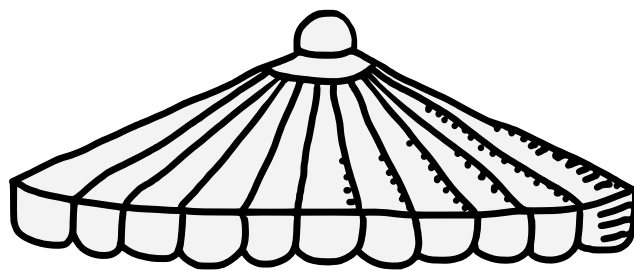
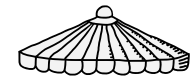
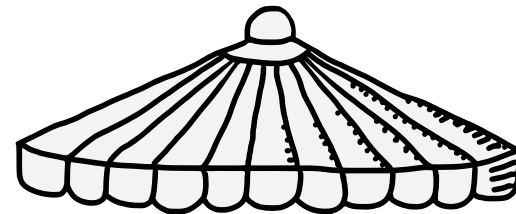
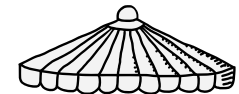
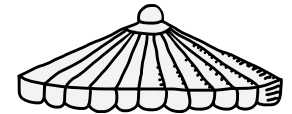
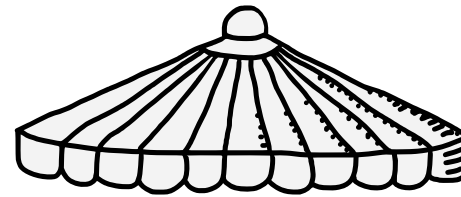
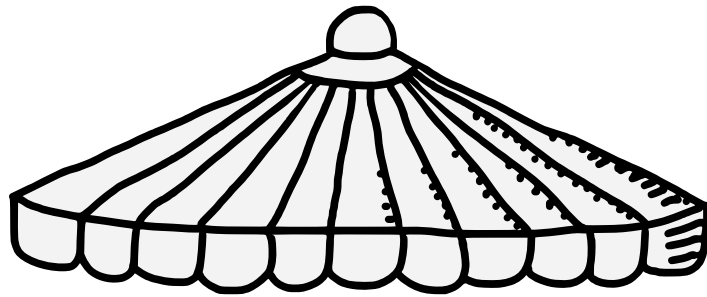
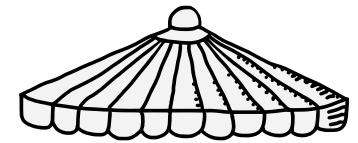
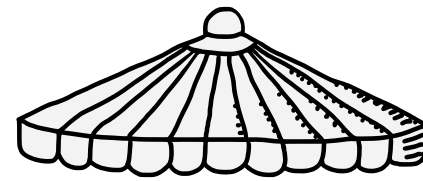
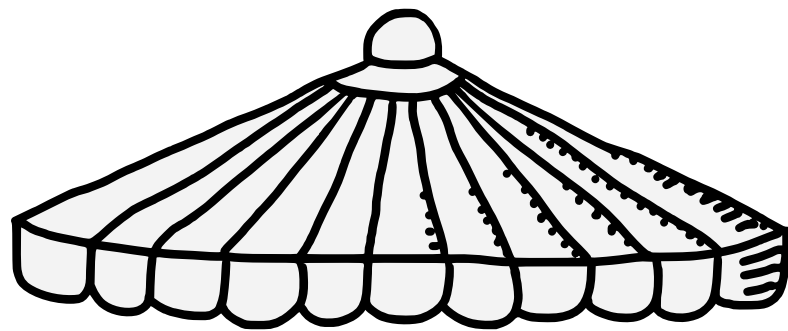

A hanging canopy, as might appear over a throne or altar.
Default orientation: point to chief. No proper coloration.
Artist: Sadhbh Bheag. Adapted by Mathghamhain Ua Ruadháin.

Baldaquin, Circular (2) 17.25

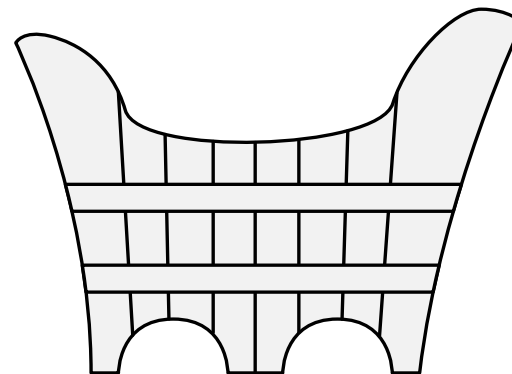
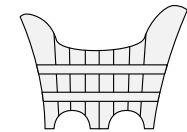
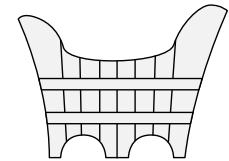
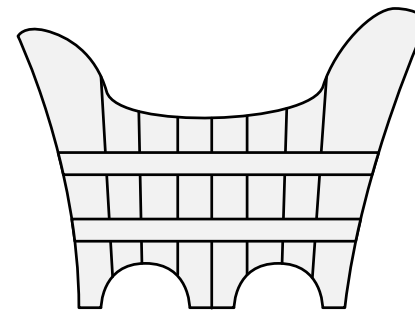
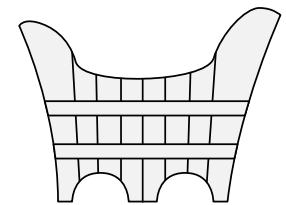
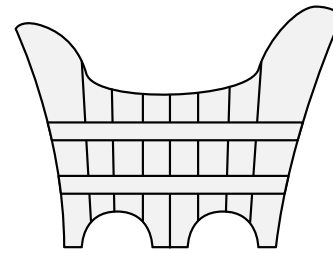
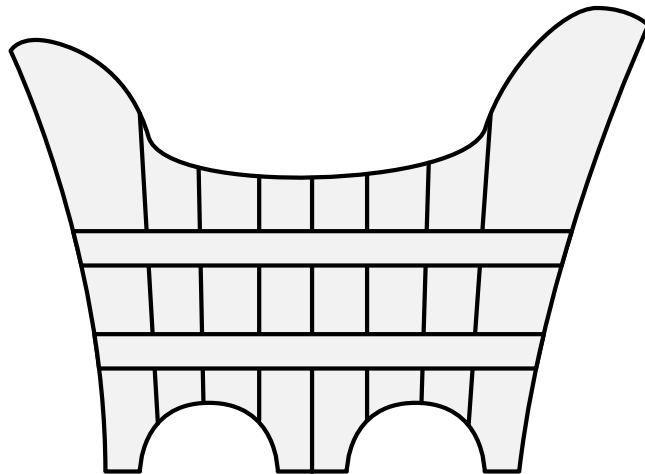
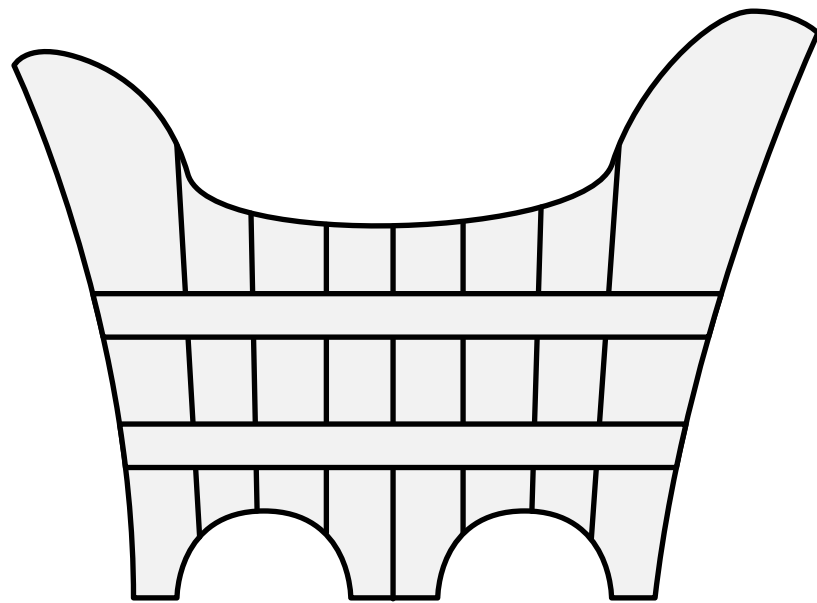

A large bucket for washing oneself.

Default orientation: upright. No proper coloration.

Source: Zurich Roll. Artist unknown. (Folio 2r, arms of Sulz.)
Adapted by Mathghamhain Ua Ruadháin.

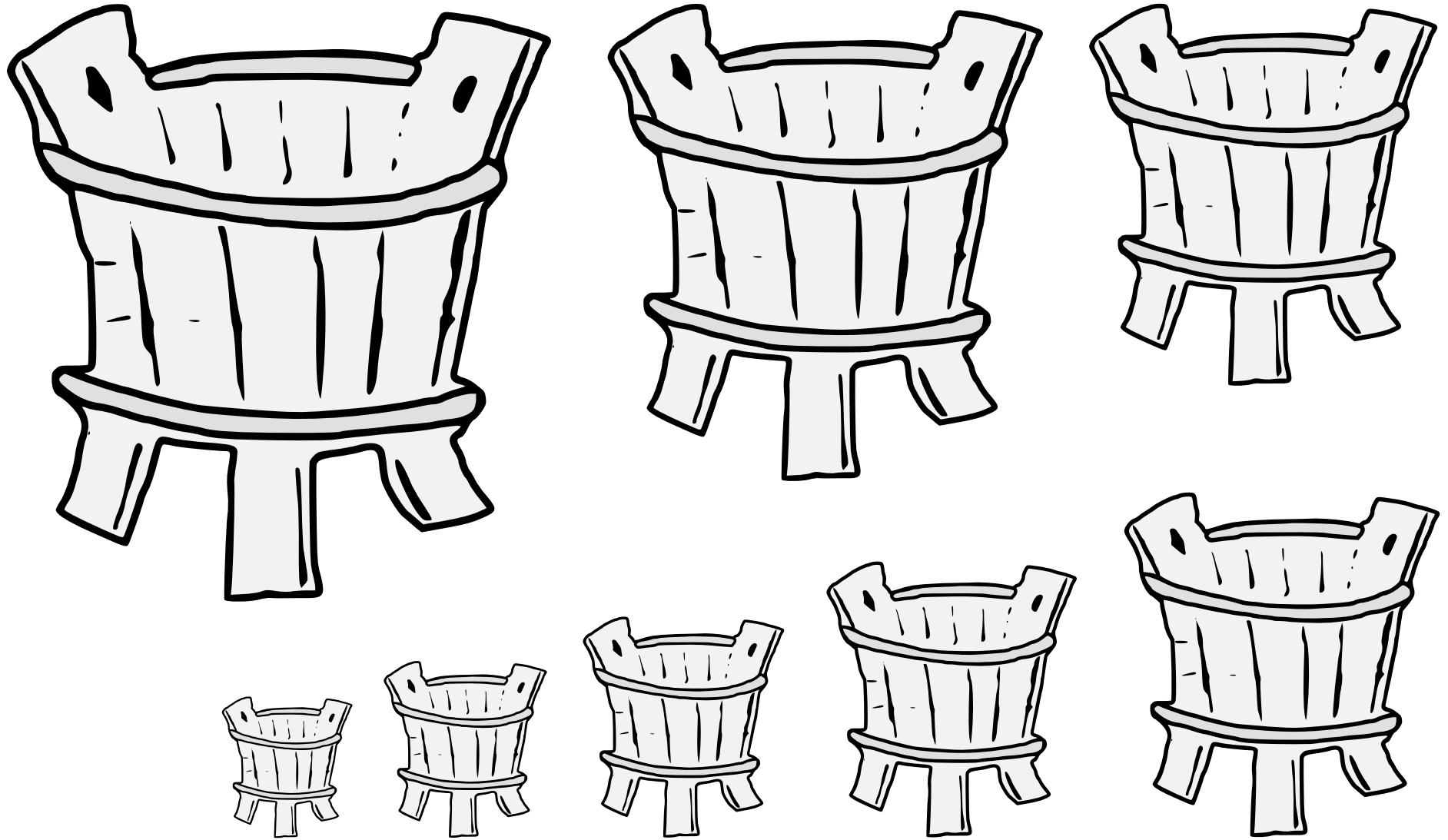

A large bucket for washing oneself.

Default orientation: upright. No proper coloration.

Source: Gemeiner loblicher Eydgnoschafft Stetten, Landen vnd Voelckeren.
Artist unknown. (Arms of von Saltz, folio 108v.)

Bath tub (2) 17.27

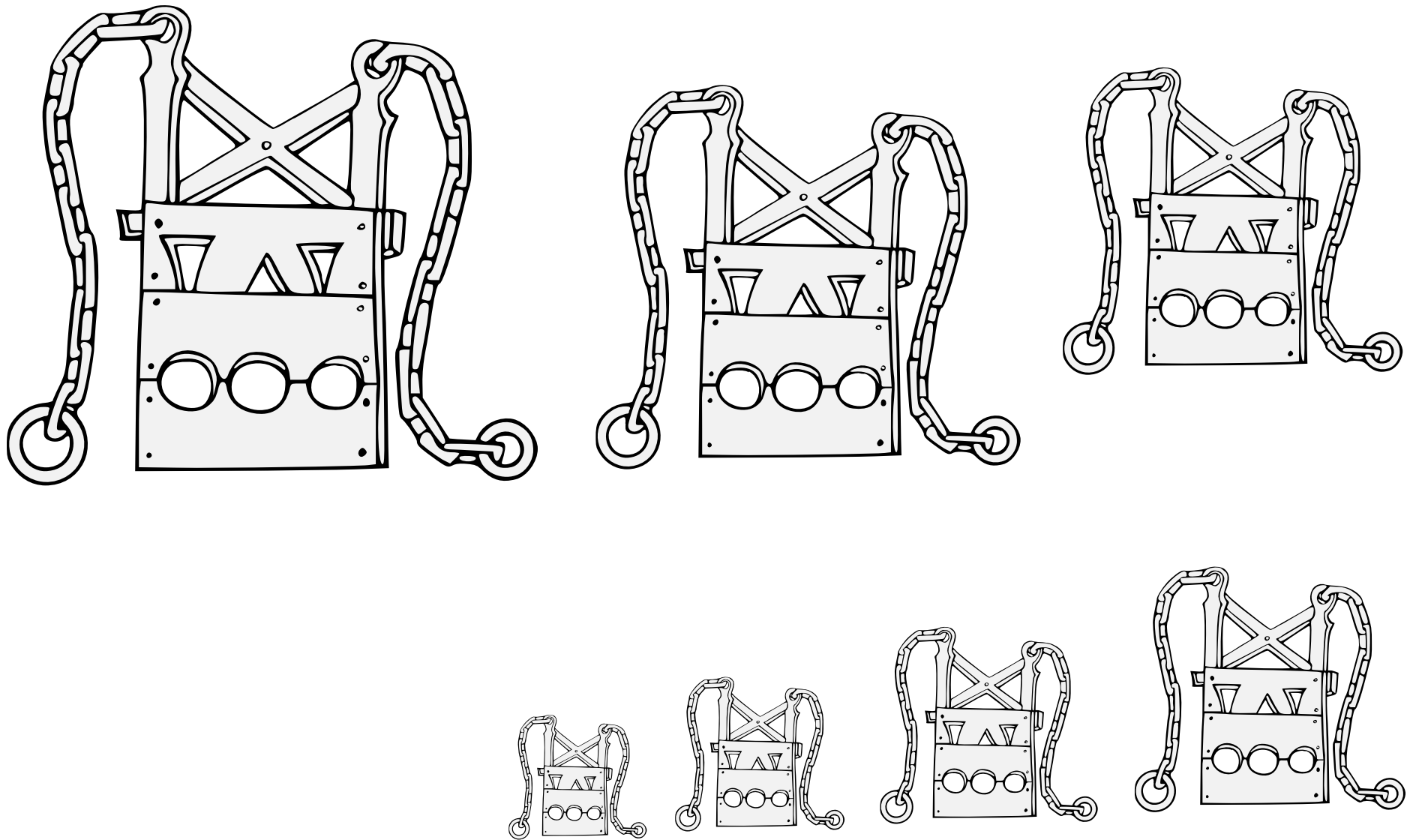

A sliding counterweight for a drawbridge.

Default orientation: palewise, sliding to chief. No default coloration.

Source: Banners, Standards, and Badges. Artist: Thomas Willement.
(A badge of the Tudor Lord Chamberlain.)

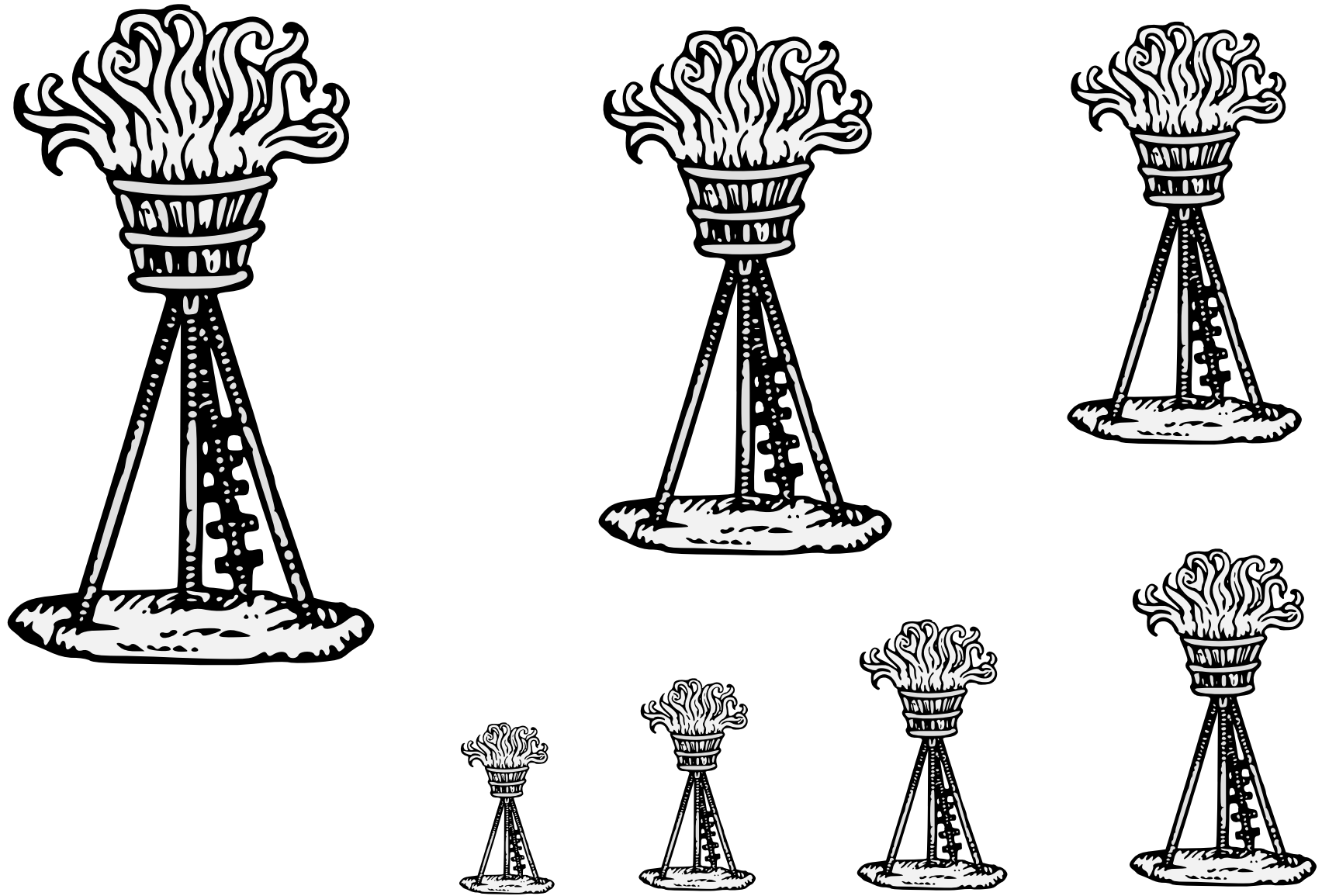

A signal tower, spewing flames.

Default orientation: flame to chief. No proper coloration.

Source: A Complete Guide to Heraldry. Artist: Graham Johnston.

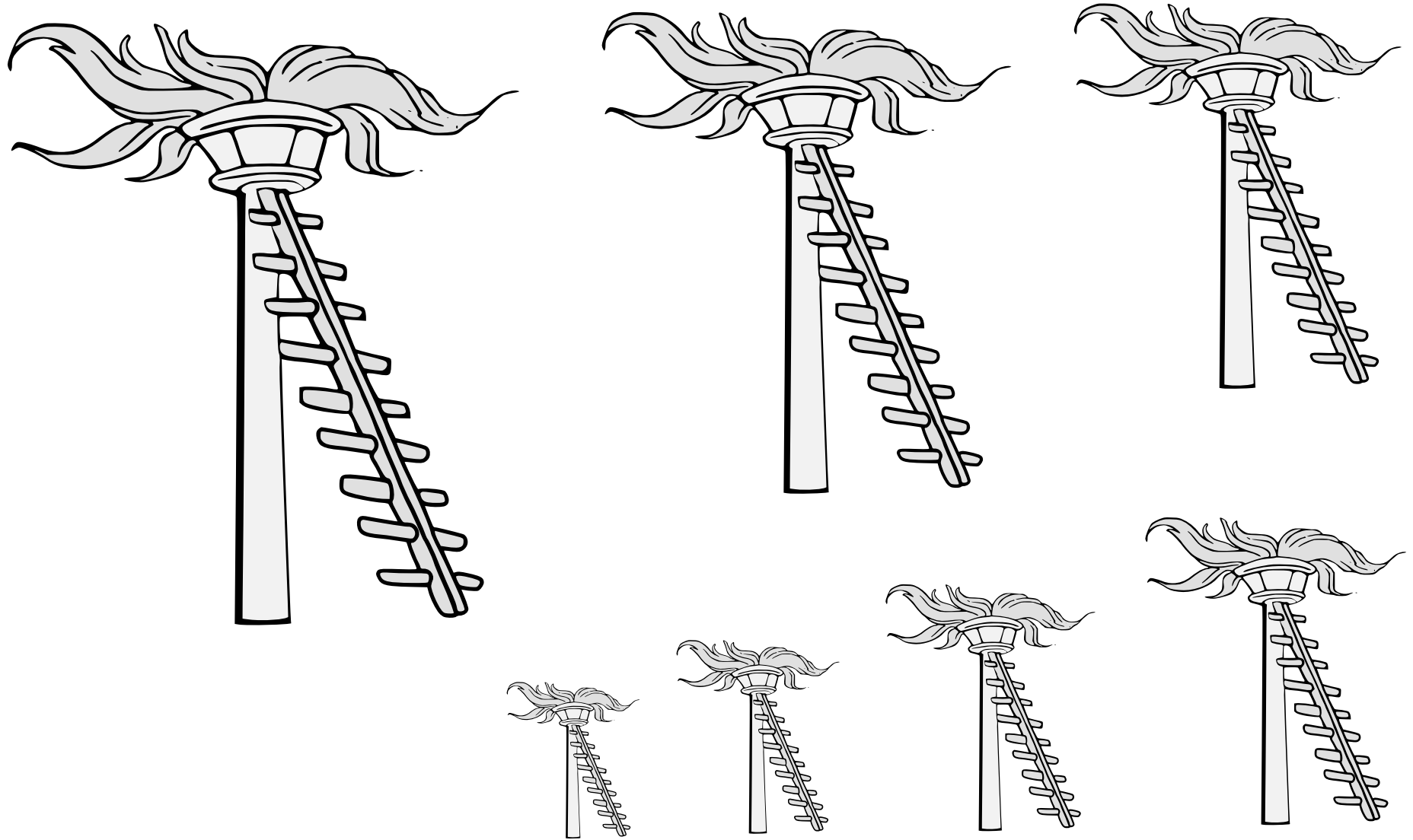

A flaming signal fire mounted on a tall pole, accessible via a ladder.

Default orientation: upright. No default coloration.

Source: Banners, Standards, and Badges. Artist: Thomas Willement.
(A badge of Edward Belknap, p. 253.)

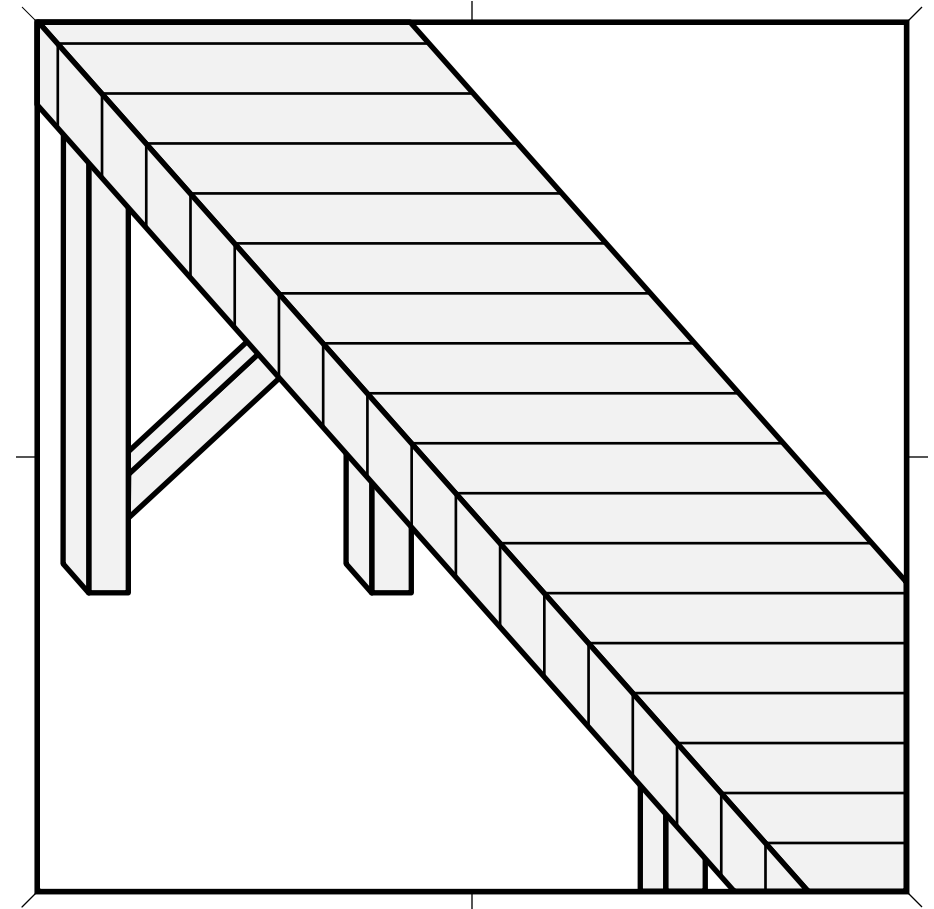
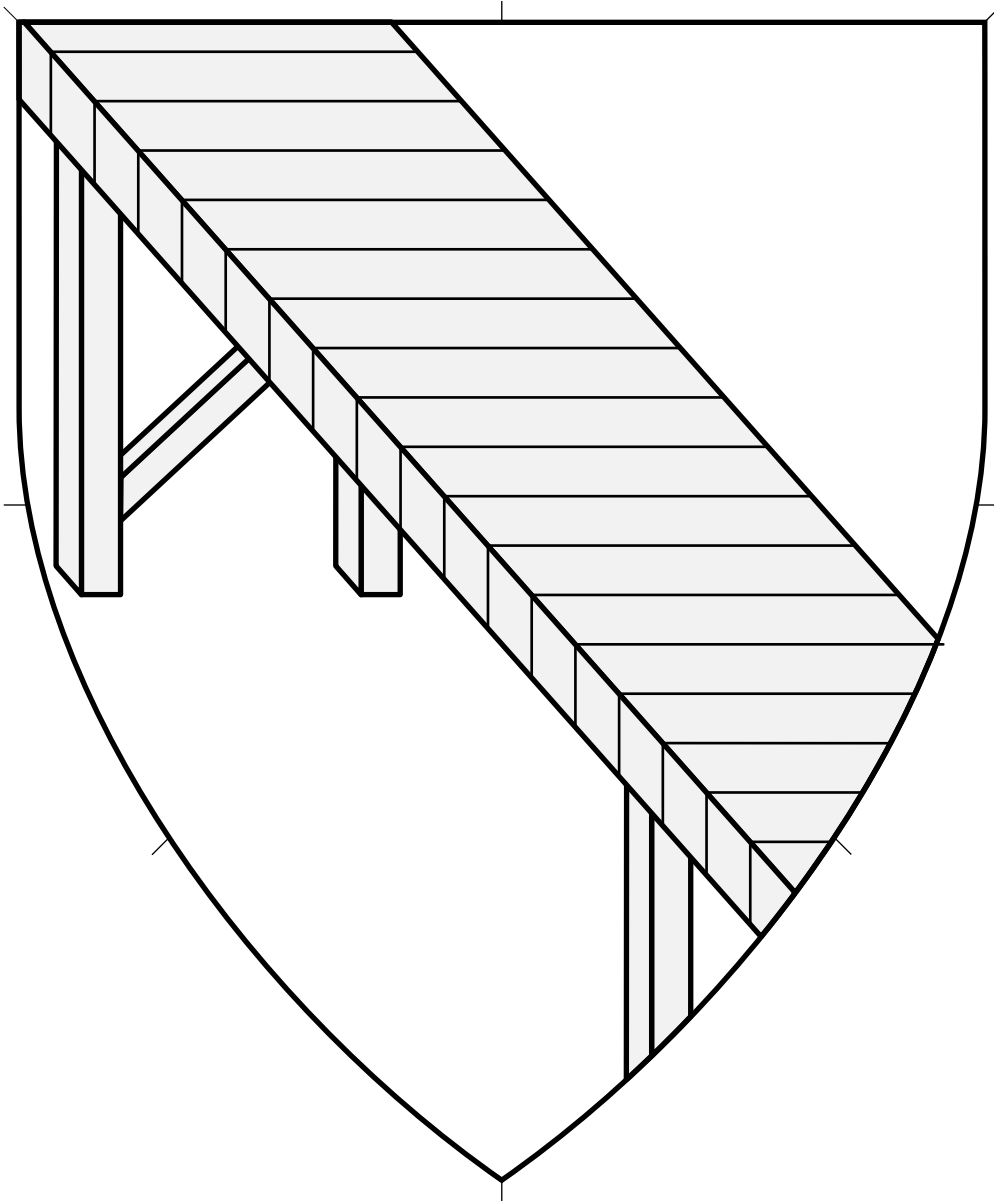

A wooden walkway supported by a framework.

No default orientation. Throughout by default. Proper coloration: brown wood.

Source: Wappenbuch der Arlberg-Bruderschaft.

Artist: Vigil Raber. (Page 91.)

Boardwalk Bendwise (1) 17.31

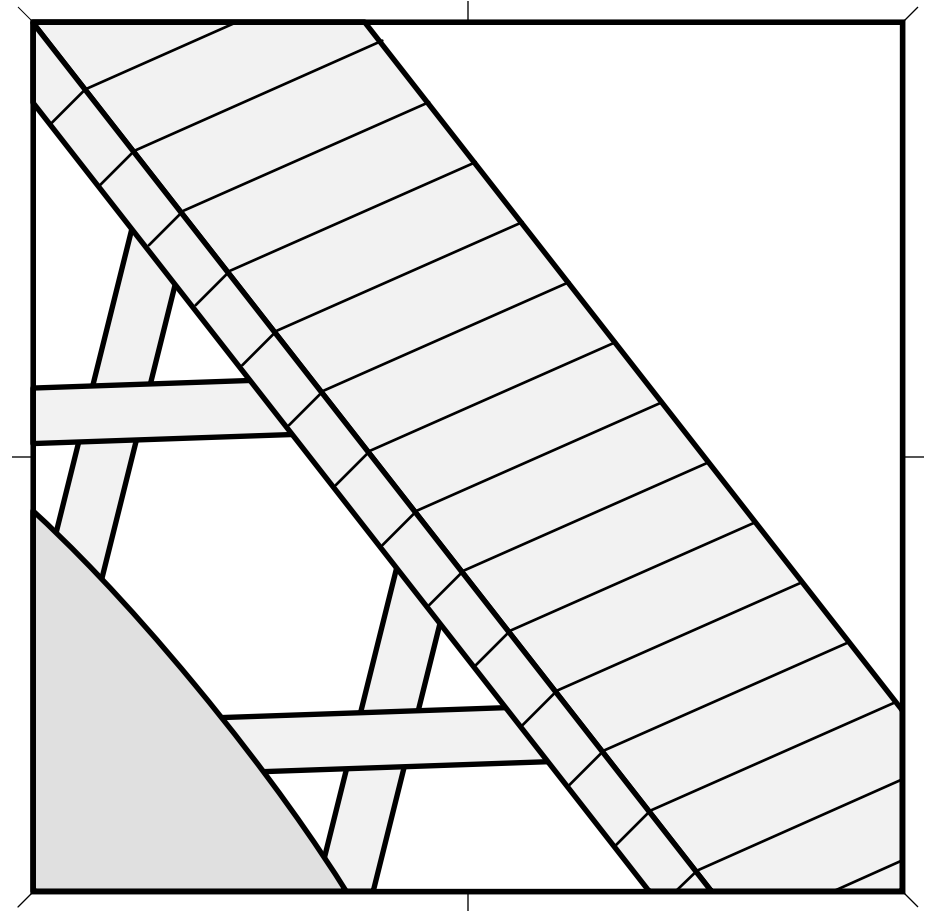
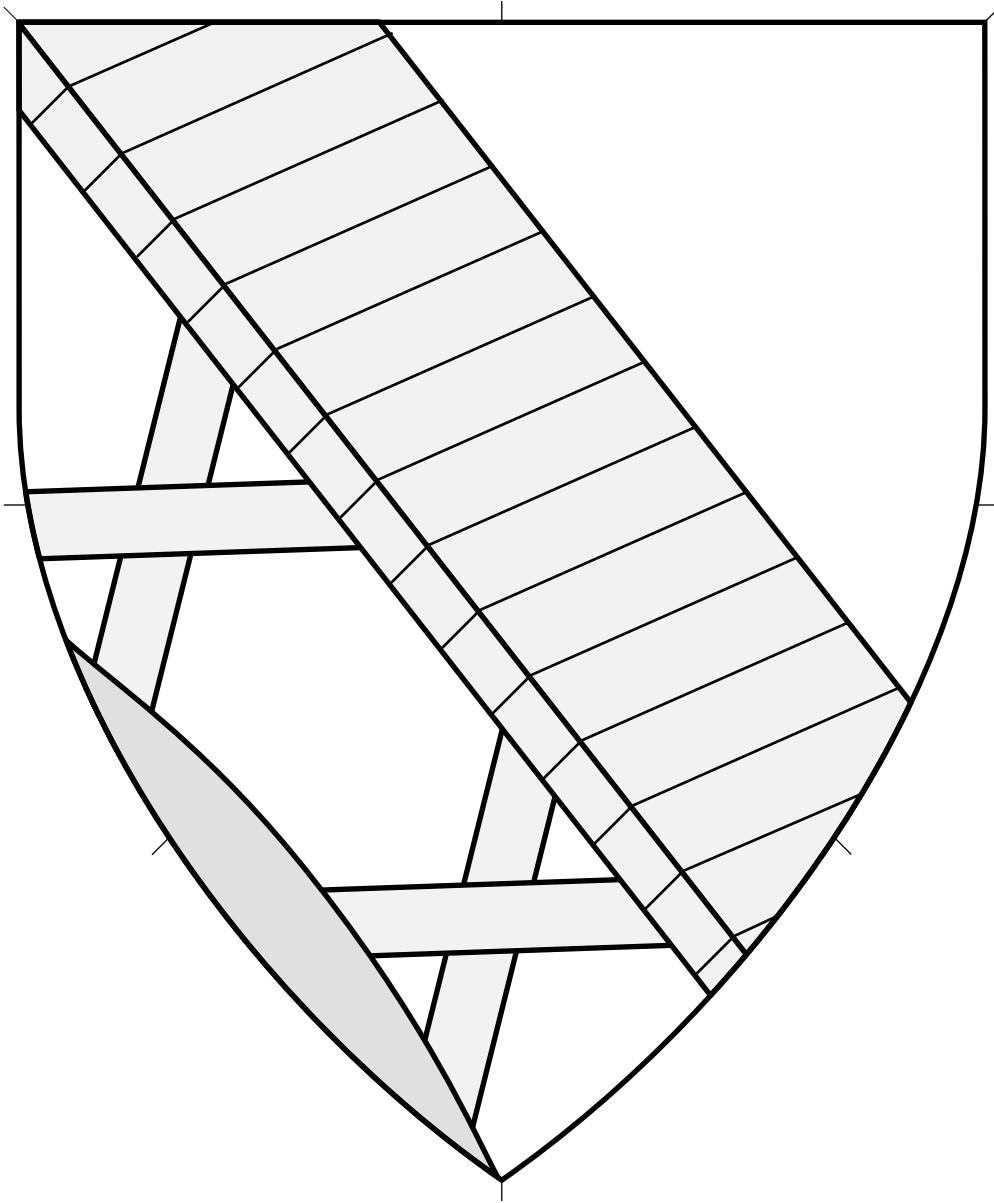

A wooden walkway supported by a framework.

No default orientation. Throughout by default. Proper coloration: brown wood.

Source: Wappenbuch der Arlberg-Bruderschaft.
Artist: Vigil Raber. (Page 333.)

Boardwalk Bendwise (2) 17.32



A metal bowl containing a flame.
Default orientation, flames to chief. No proper coloration.
Source: Sledgehammer. Artist: Grimwulf Harland.

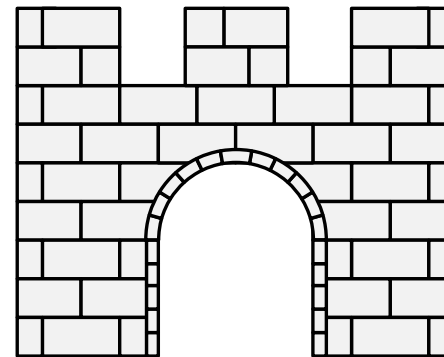
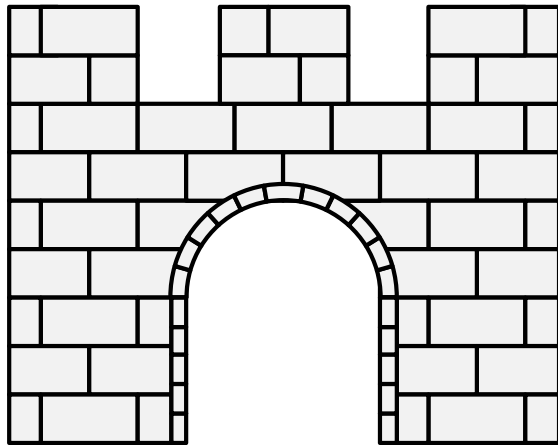
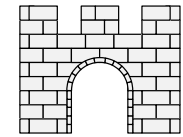
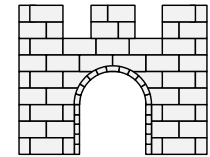
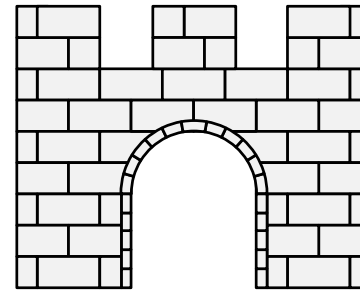
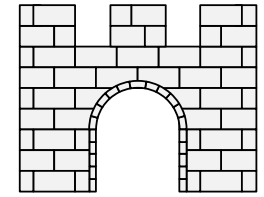
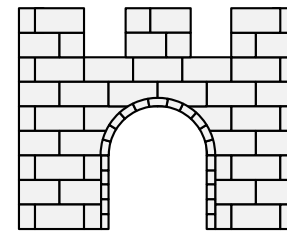
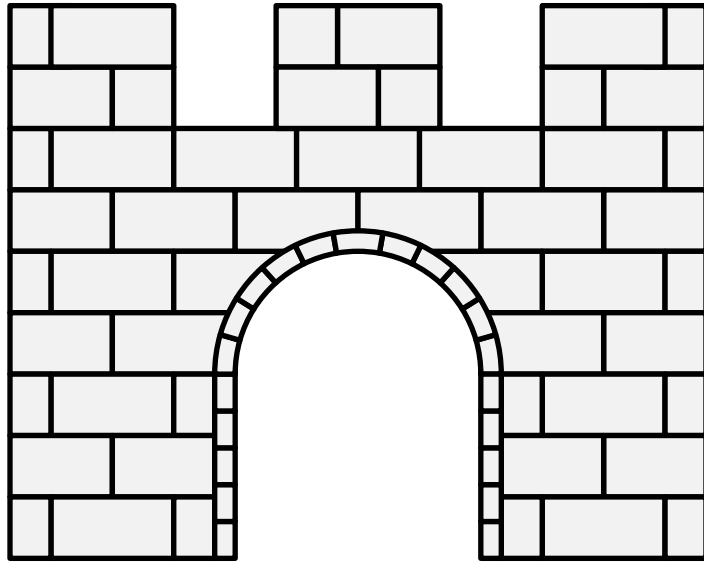

A structure for traveling over a river.
Default orientation: fesswise. No proper coloration.

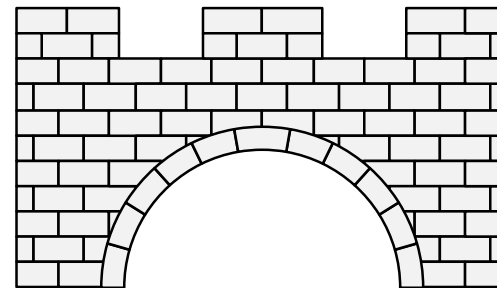
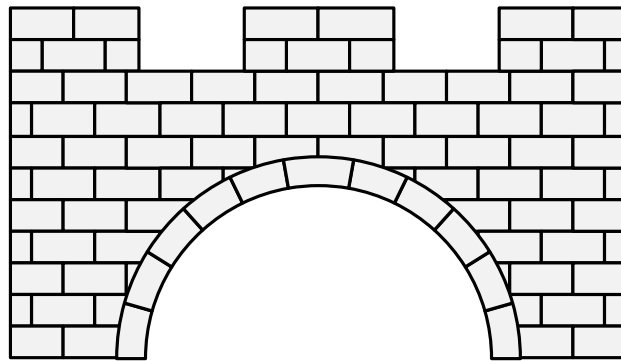
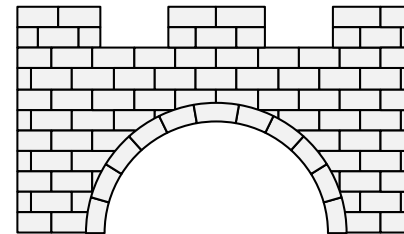
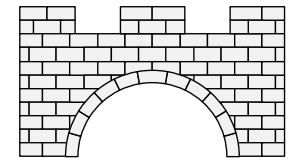
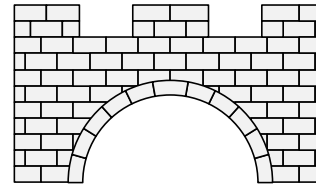
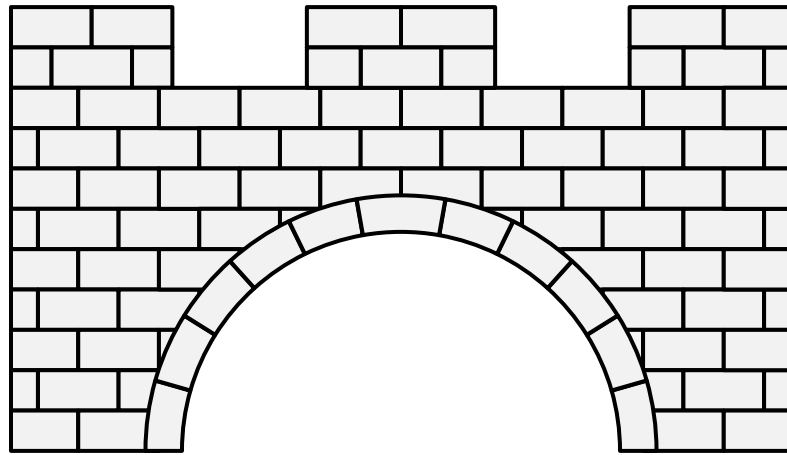

A structure for traveling over a river.
Default orientation: fesswise. No proper coloration.

Bridge of One Arch (2) 17.35

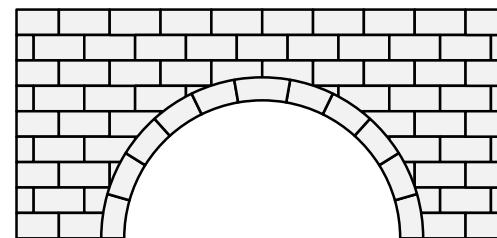
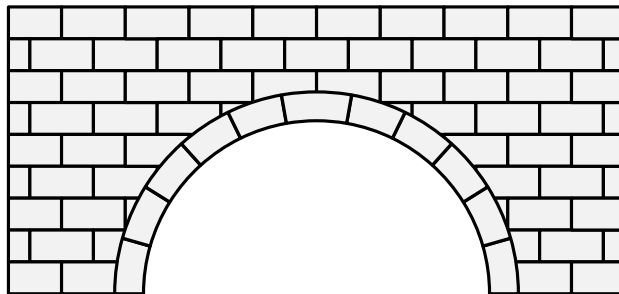
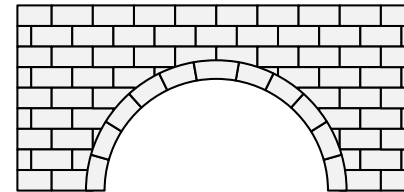
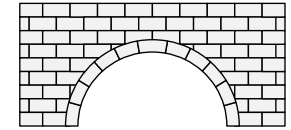
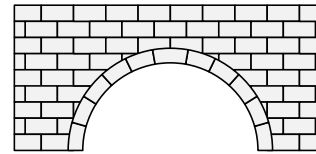
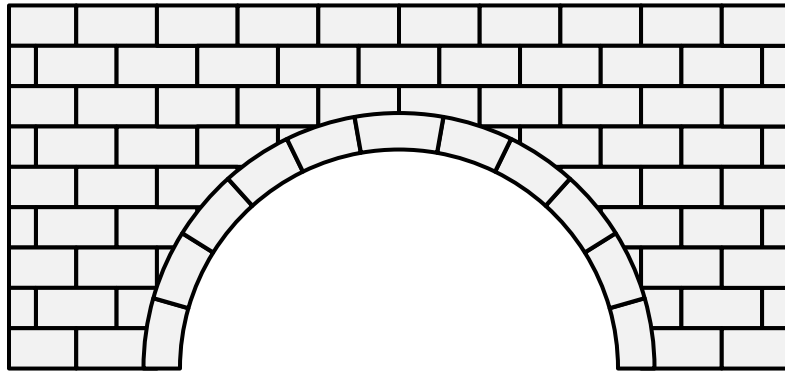

A structure for traveling over a river.

Default orientation: fesswise. No proper coloration.

Adapted by Fenneke Jans.

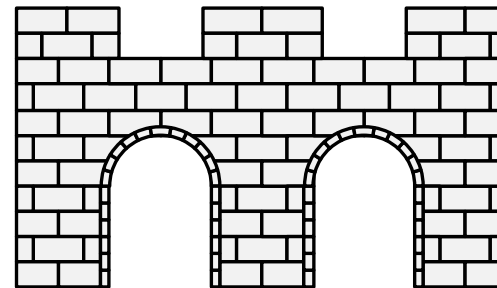
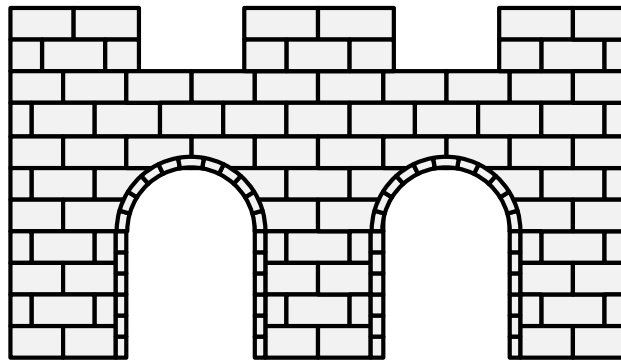
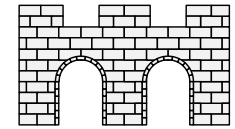
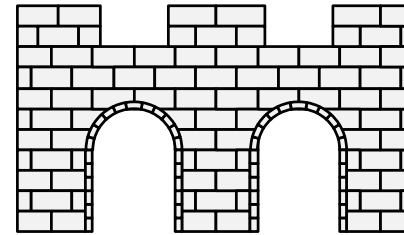
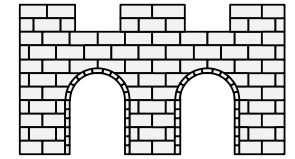
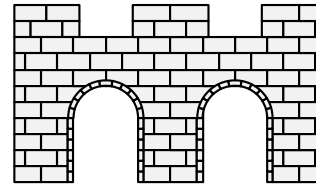
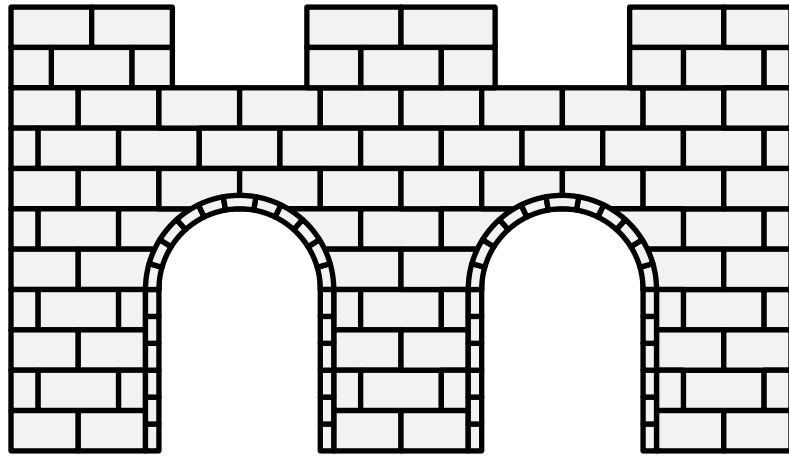

A structure for traveling over a river.
Default orientation: fesswise. No proper coloration.

Bridge of Two Arches (1) 17.37

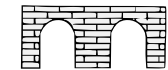
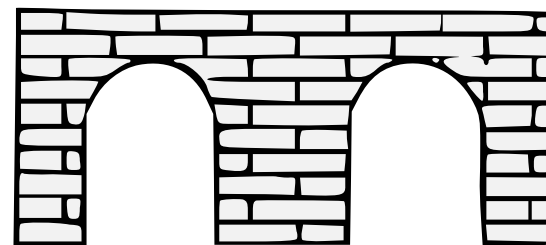
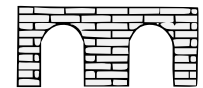
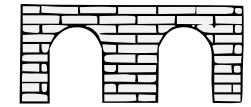
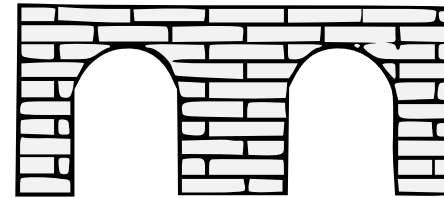
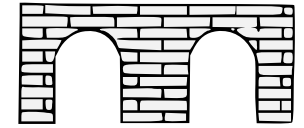
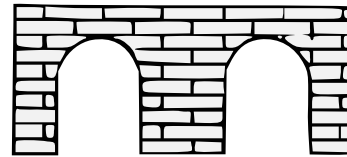
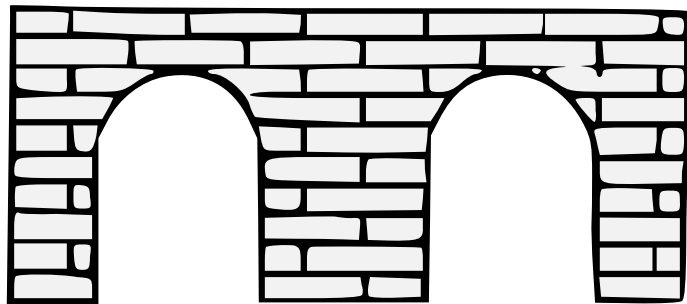
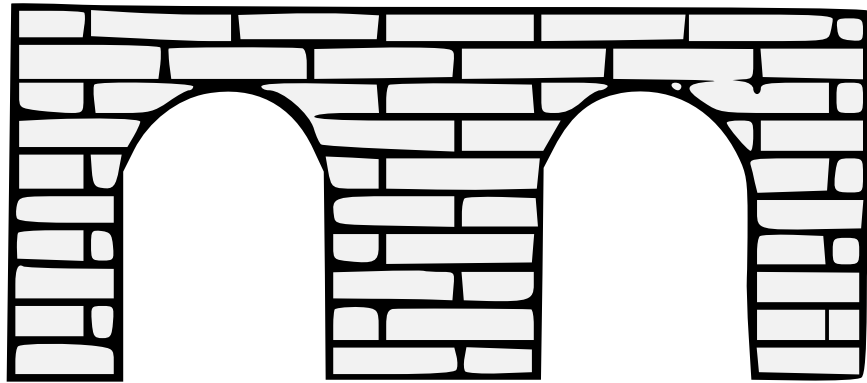

A structure for traveling over a river.

Default orientation: fesswise. No proper coloration.

Source: Pennsic Traceable Art. Artist unknown.

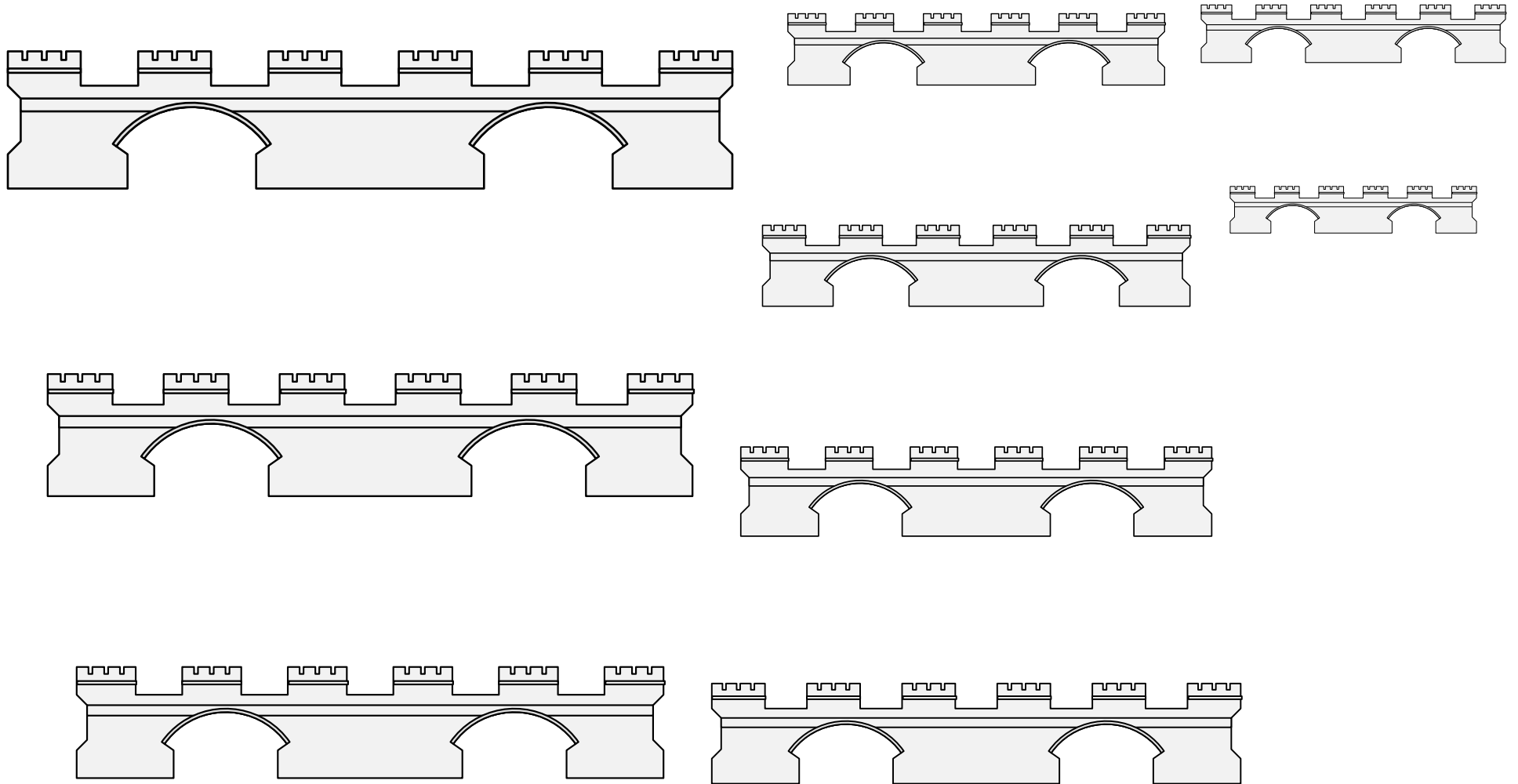

A structure for traveling over a river.

Default orientation: fesswise. No proper coloration.

Source: Pennsic Herald's Point Artists. Artist: Bahja al-Azraq.
Adapted by Mathghamhain Ua Ruadháin.

Bridge of Two Arches (3) 17.39

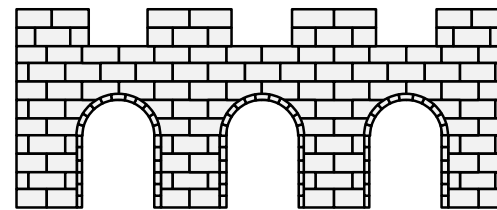
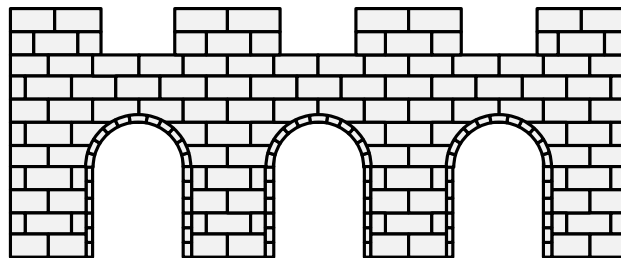
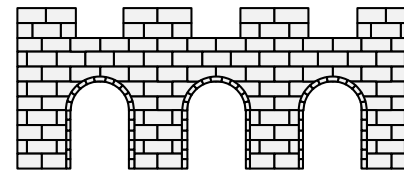
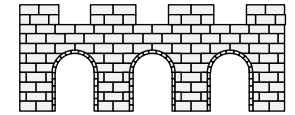
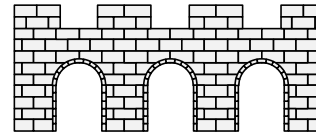
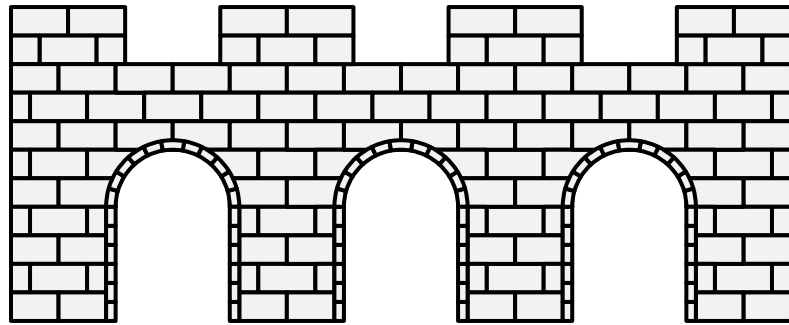

A structure for traveling over a river.
Default orientation: fesswise. No proper coloration.

Bridge of Three Arches (1) 17.40

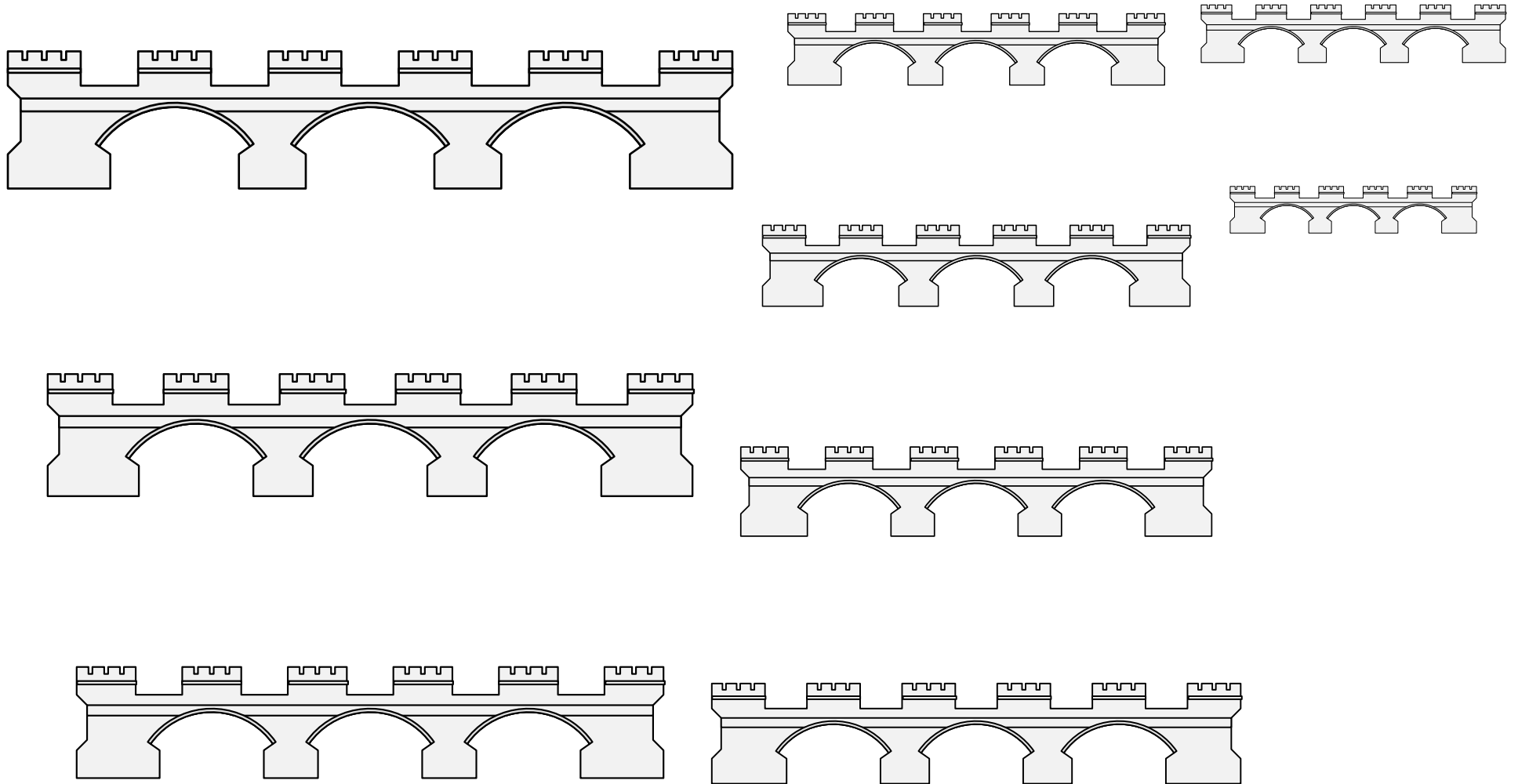

A structure for traveling over a river.

Default orientation: fesswise. No proper coloration.

Source: Pennsic Herald's Point Artists. Artist: Bahja al-Azraq.
Adapted by Mathghamhain Ua Ruadháin.

Bridge Of Three Arches (2) 17.41

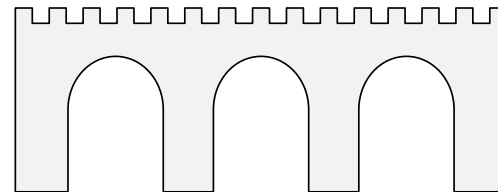
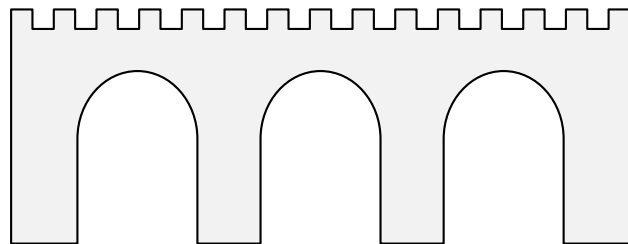
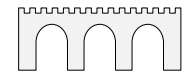
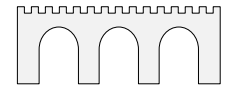
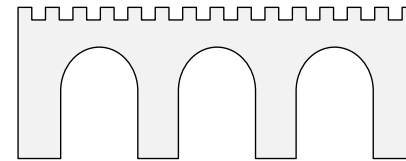
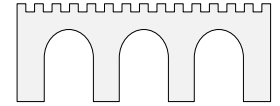
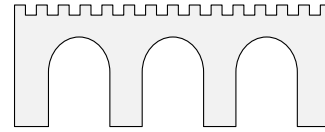
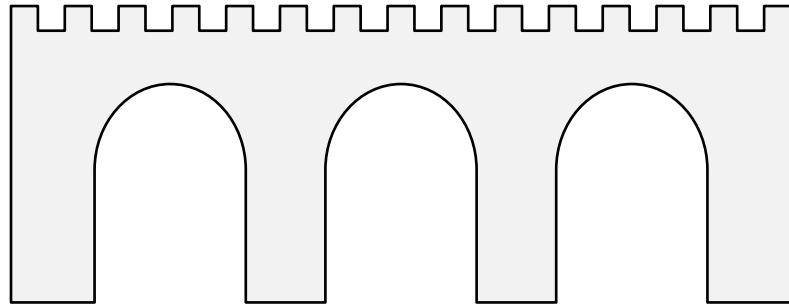

A structure for traveling over a river.
Default orientation: fesswise. No proper coloration.

Bridge Of Three Arches (3) 17.42

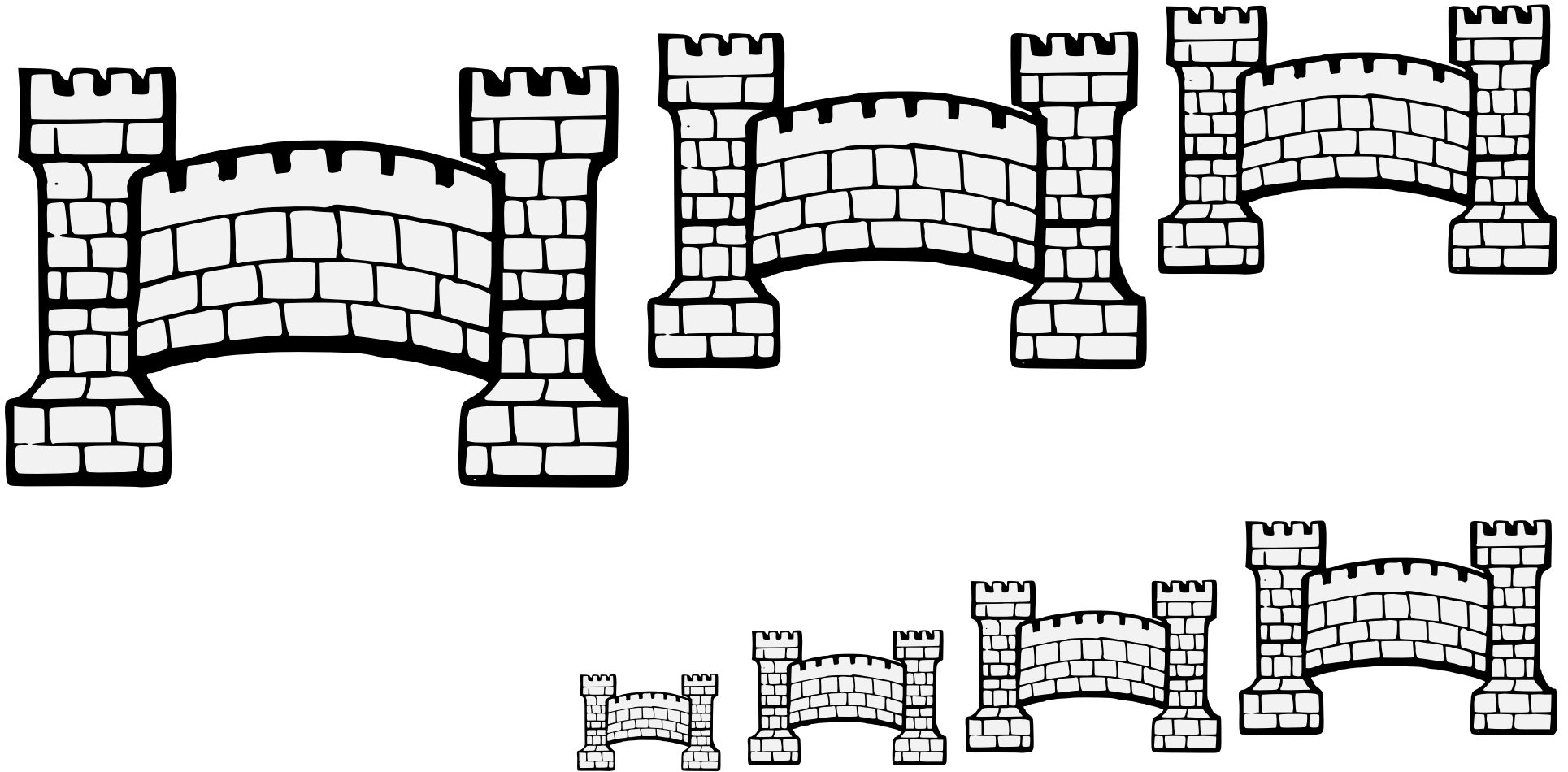

A structure for traveling over a river.

Default orientation: fesswise. No proper coloration.

Source: Two Tudor Books of Arms. Artist: Robert Cooke. (From page p152, arms of Wylyam Arche.)

Bridge, Twin-Towered, Of A Single Arch 17.43

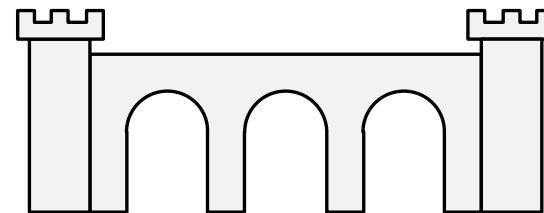
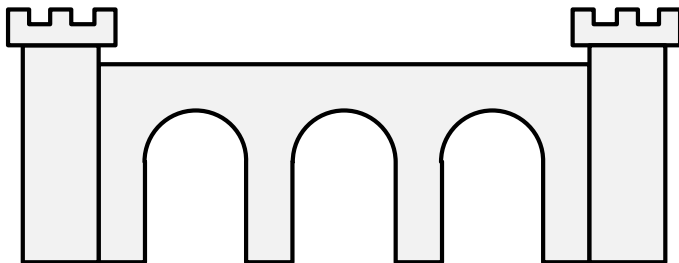
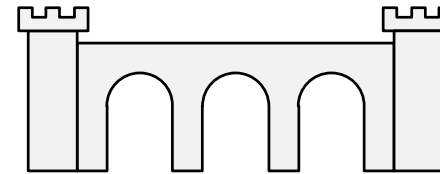
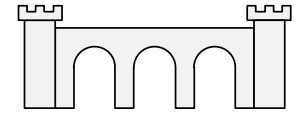
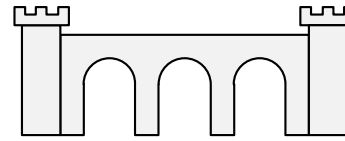
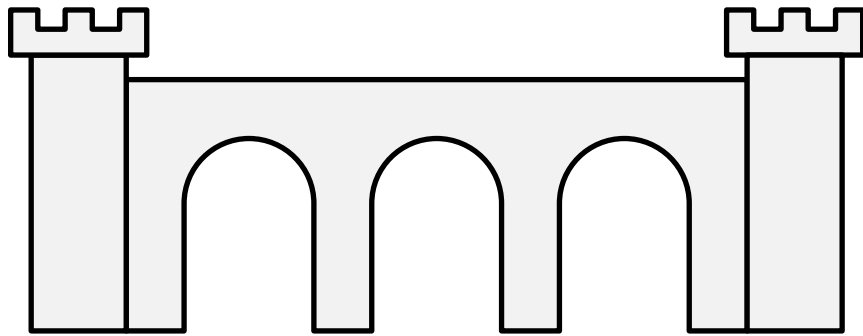

A structure for traveling over a river.

Default orientation: fesswise. No proper coloration.

Source: Pennsic Traceable Art. Artist unknown. Adapted by Mathghamhain Ua Ruadháin.

Bridge, Twin-Towered, Of Three Arches (1) 17.44

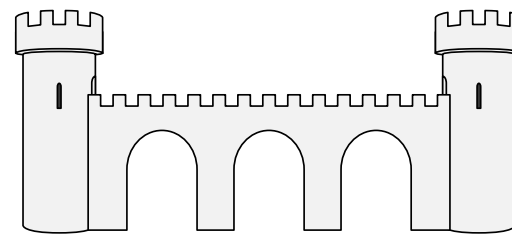
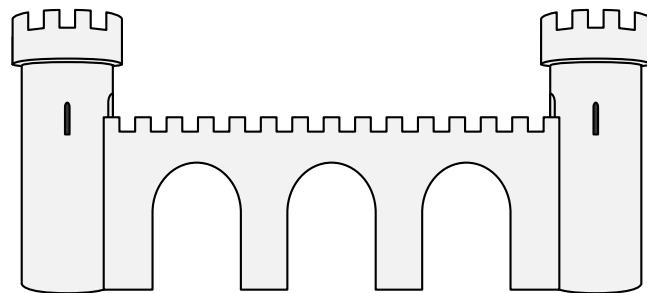
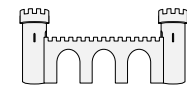
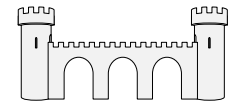
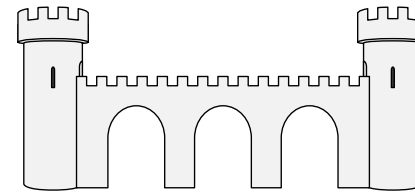
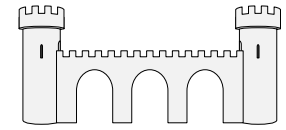
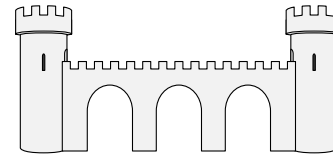
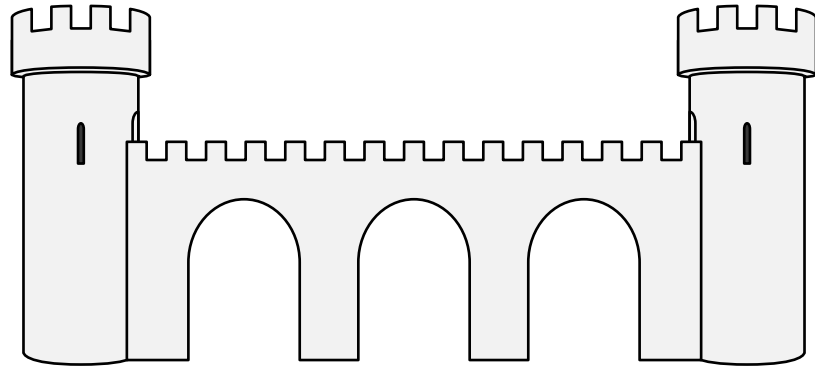

A structure for traveling over a river.

Default orientation: fesswise. No proper coloration.

Bridge, Twin-Towered, Of Three Arches (2) 17.45

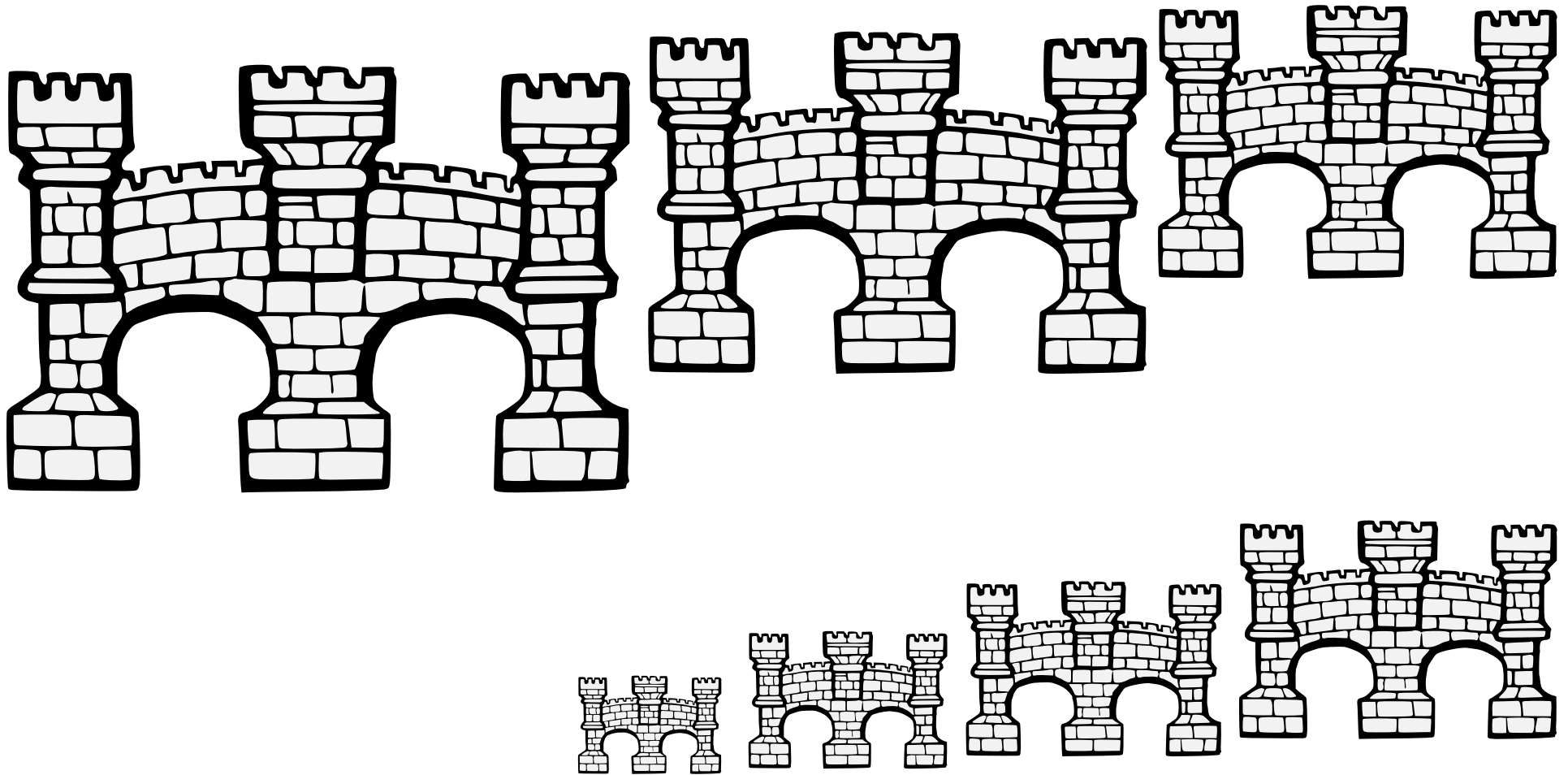

A structure for traveling over a river.

Default orientation: fesswise. No proper coloration.

Source: Two Tudor Books of Arms. Artist: Robert Cooke. (From page p152, arms of Wylyam Arche.)

Bridge, Triple-Towered, Of Two Arches 17.46

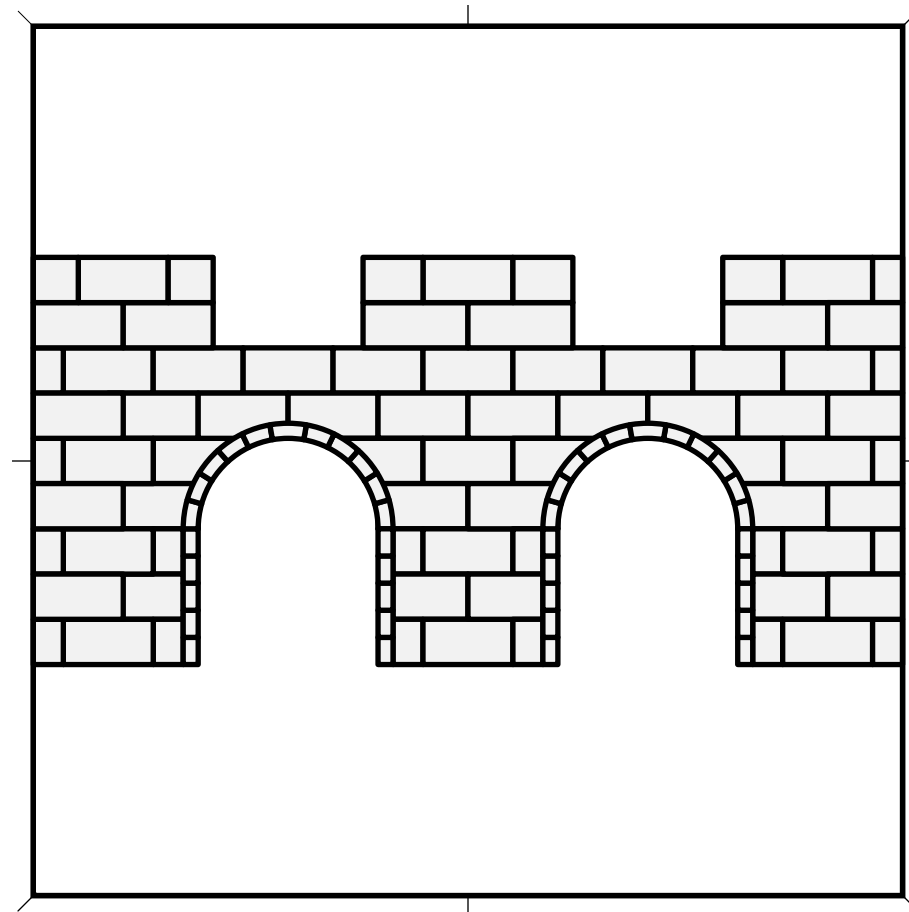
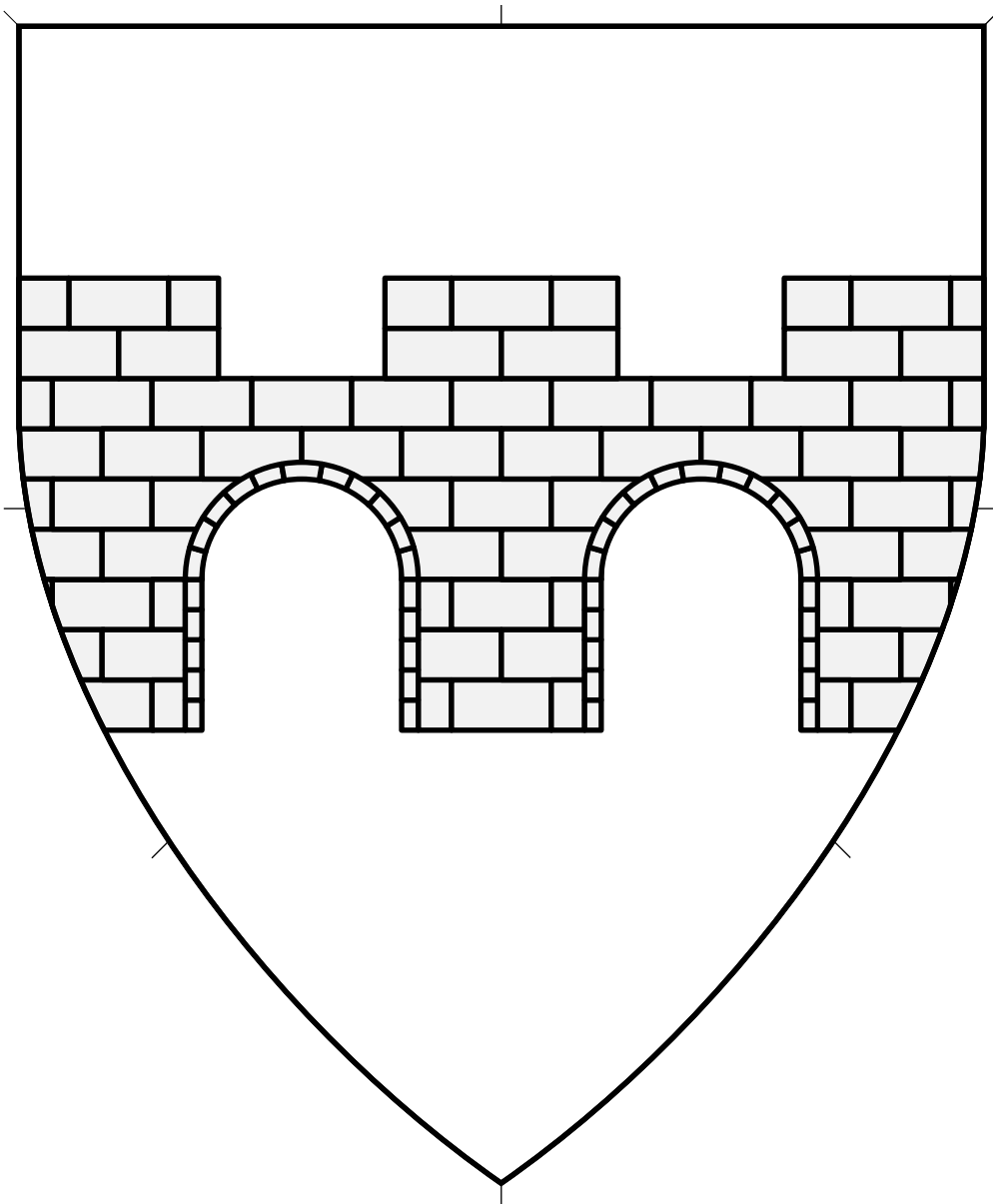

A structure for traveling over a river.

Default orientation: fesswise. No proper coloration.

Bridge Throughout of Two Arches 17.47

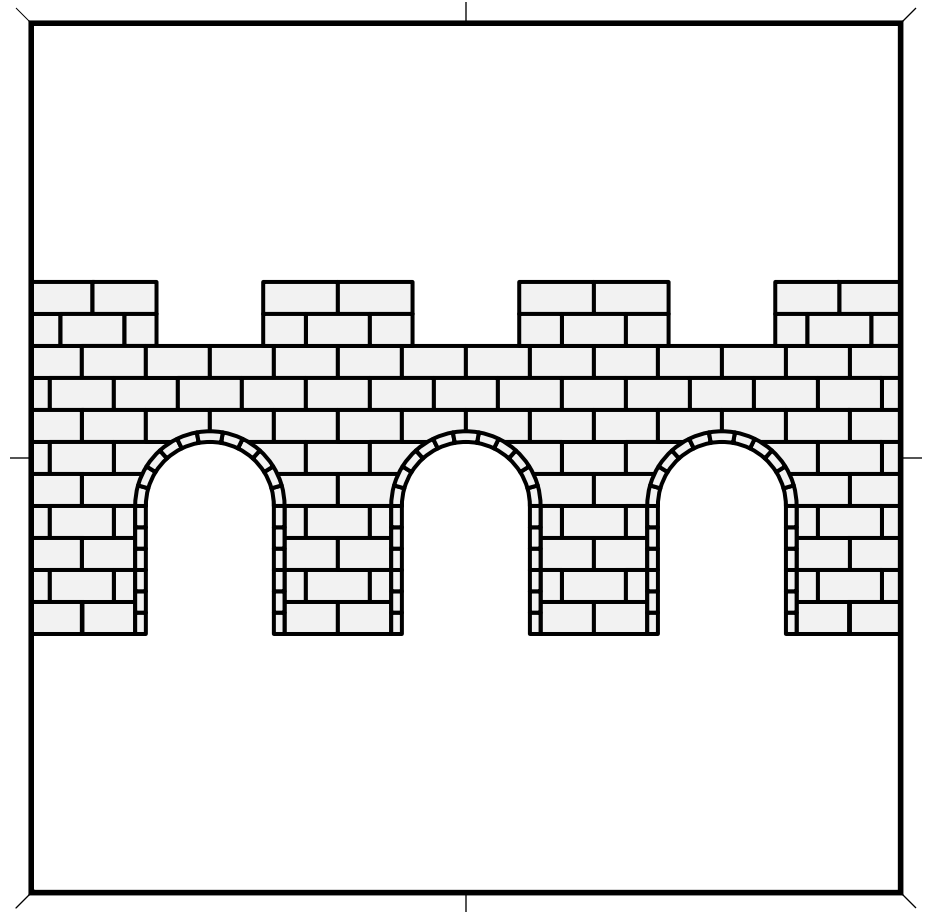
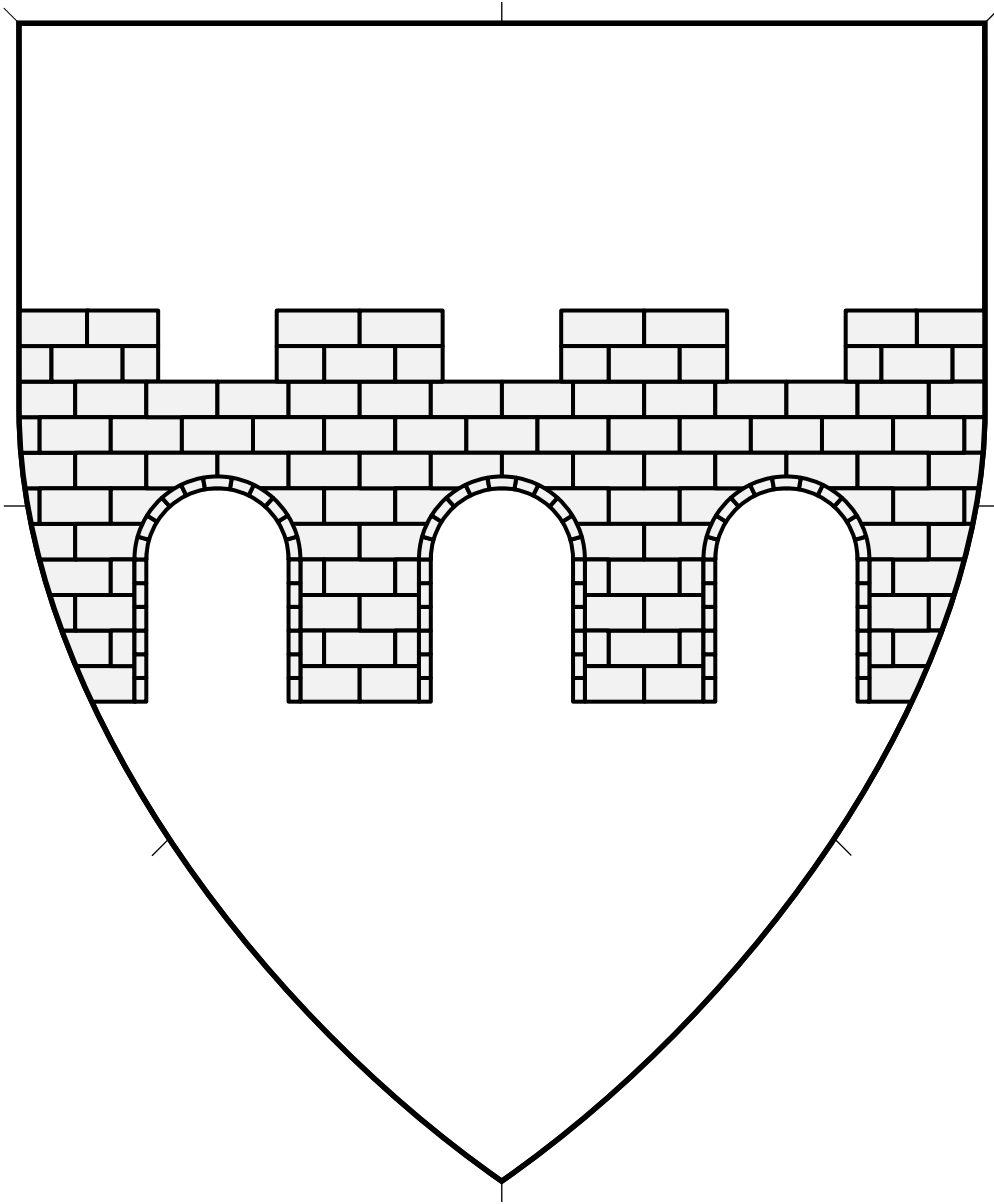

A structure for traveling over a river.

Default orientation: fesswise. No proper coloration.

Bridge Throughout of Three Arches (1) 17.48

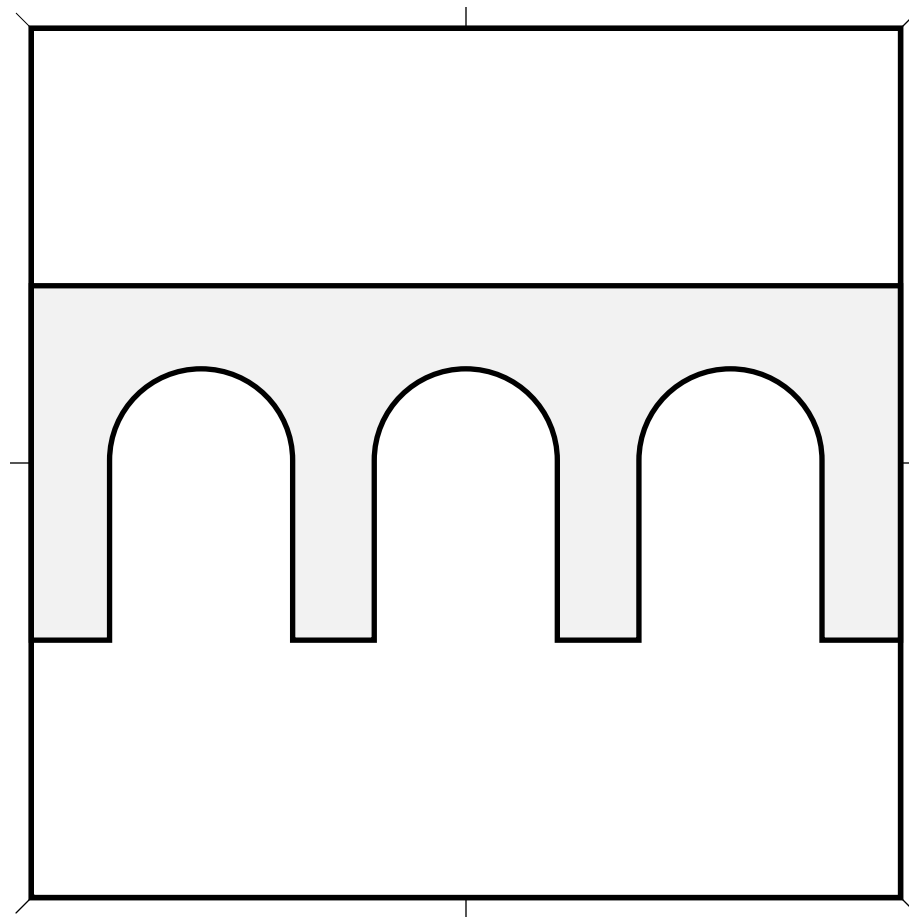
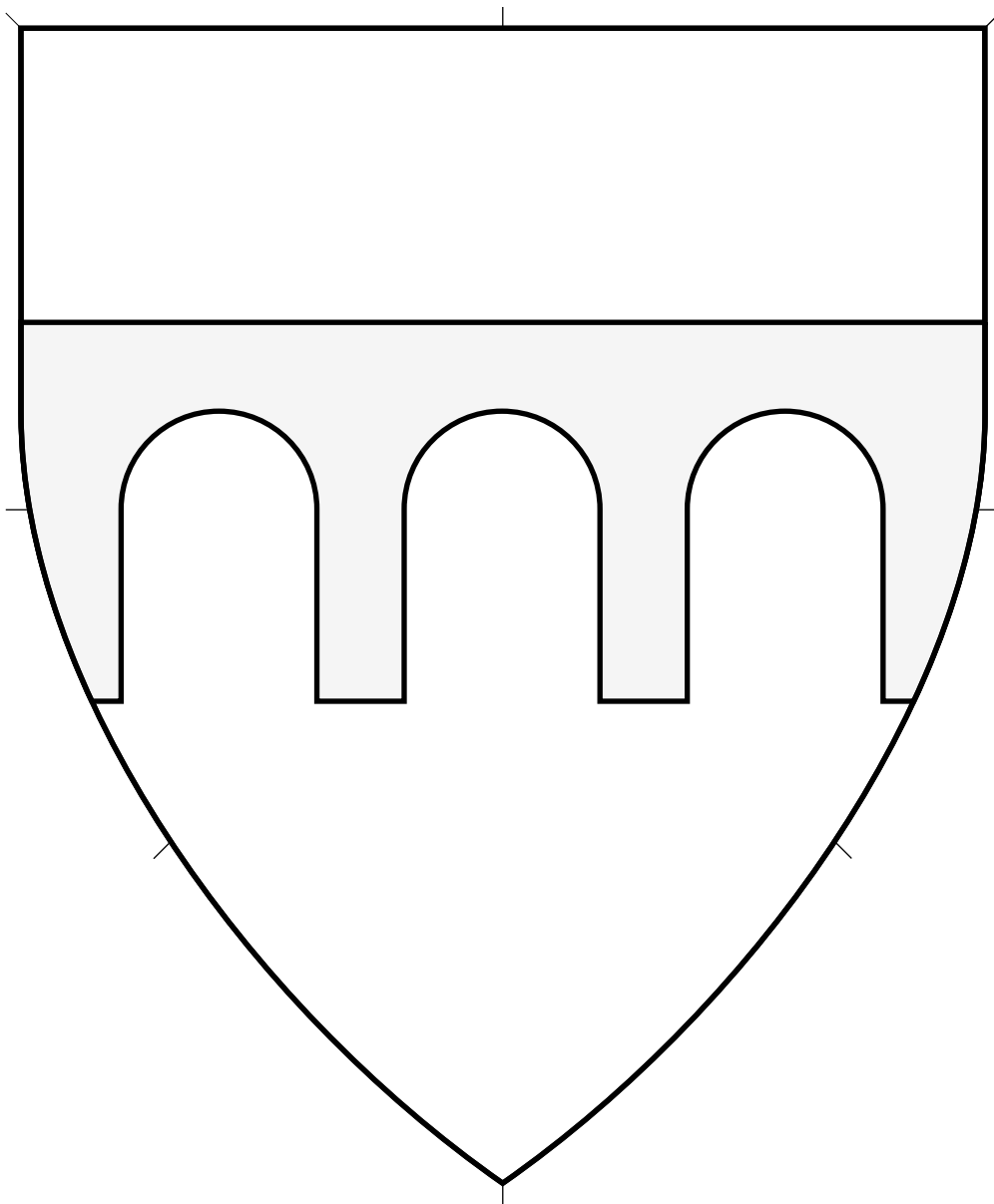

A structure for traveling over a river.

Default orientation: fesswise. No proper coloration.

Bridge Throughout of Three Arches (2) 17.49

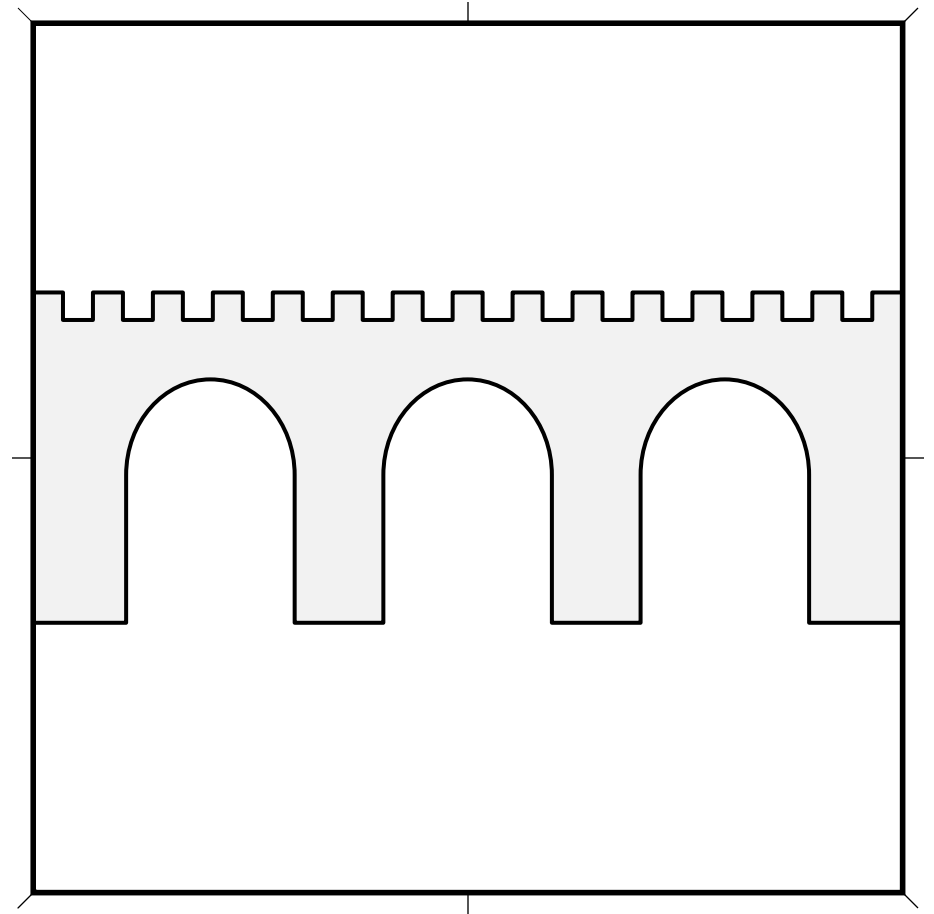
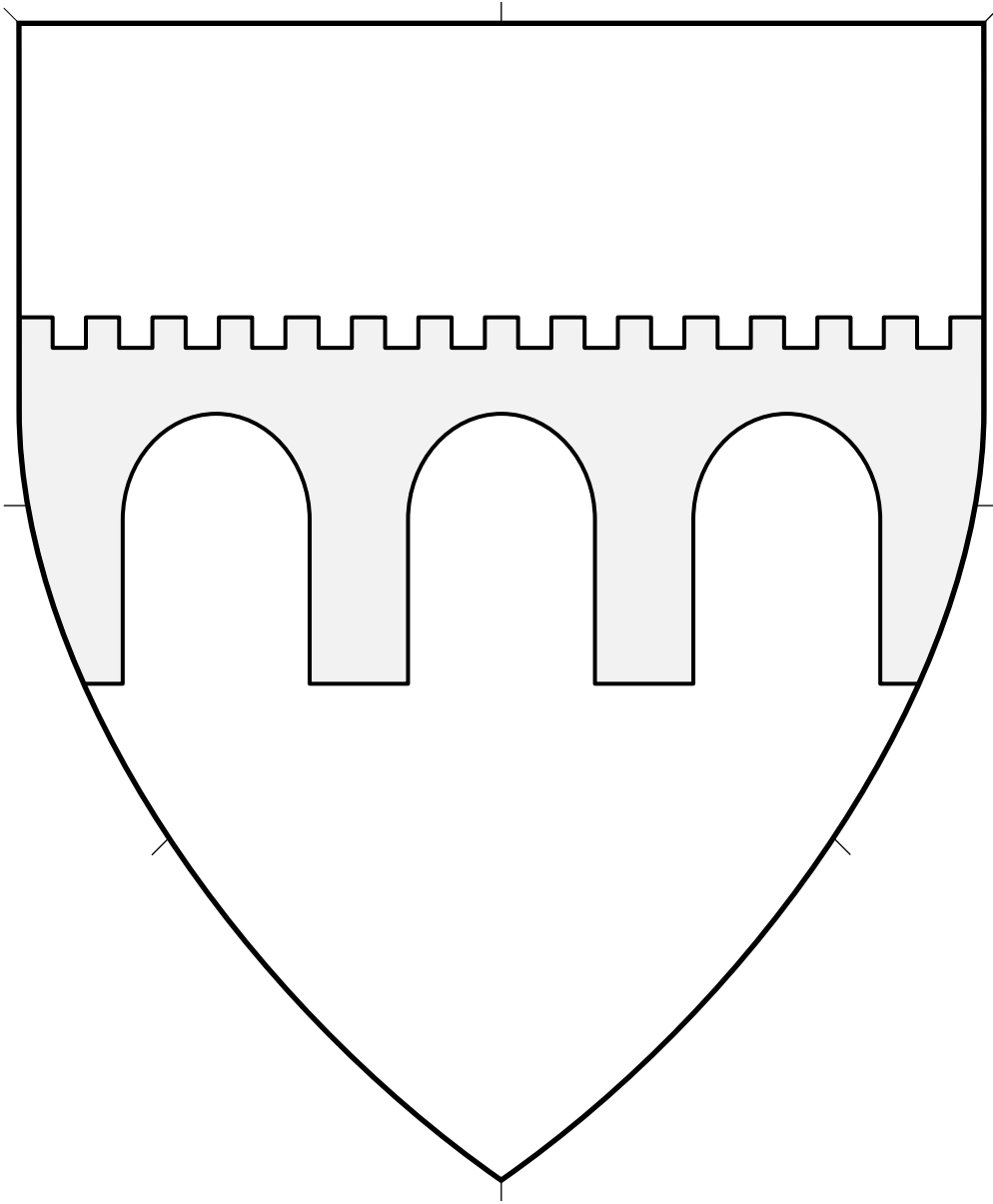

A structure for traveling over a river.

Default orientation: fesswise. No proper coloration.

Bridge Throughout of Three Arches (3) 17.50

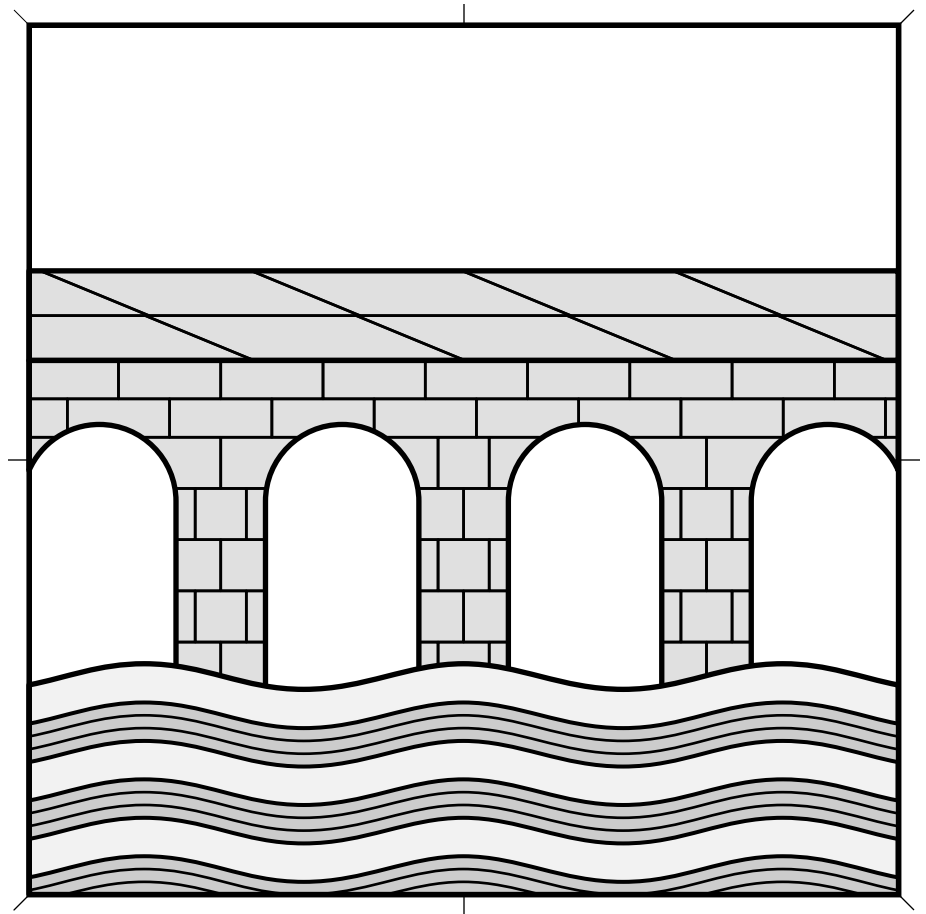
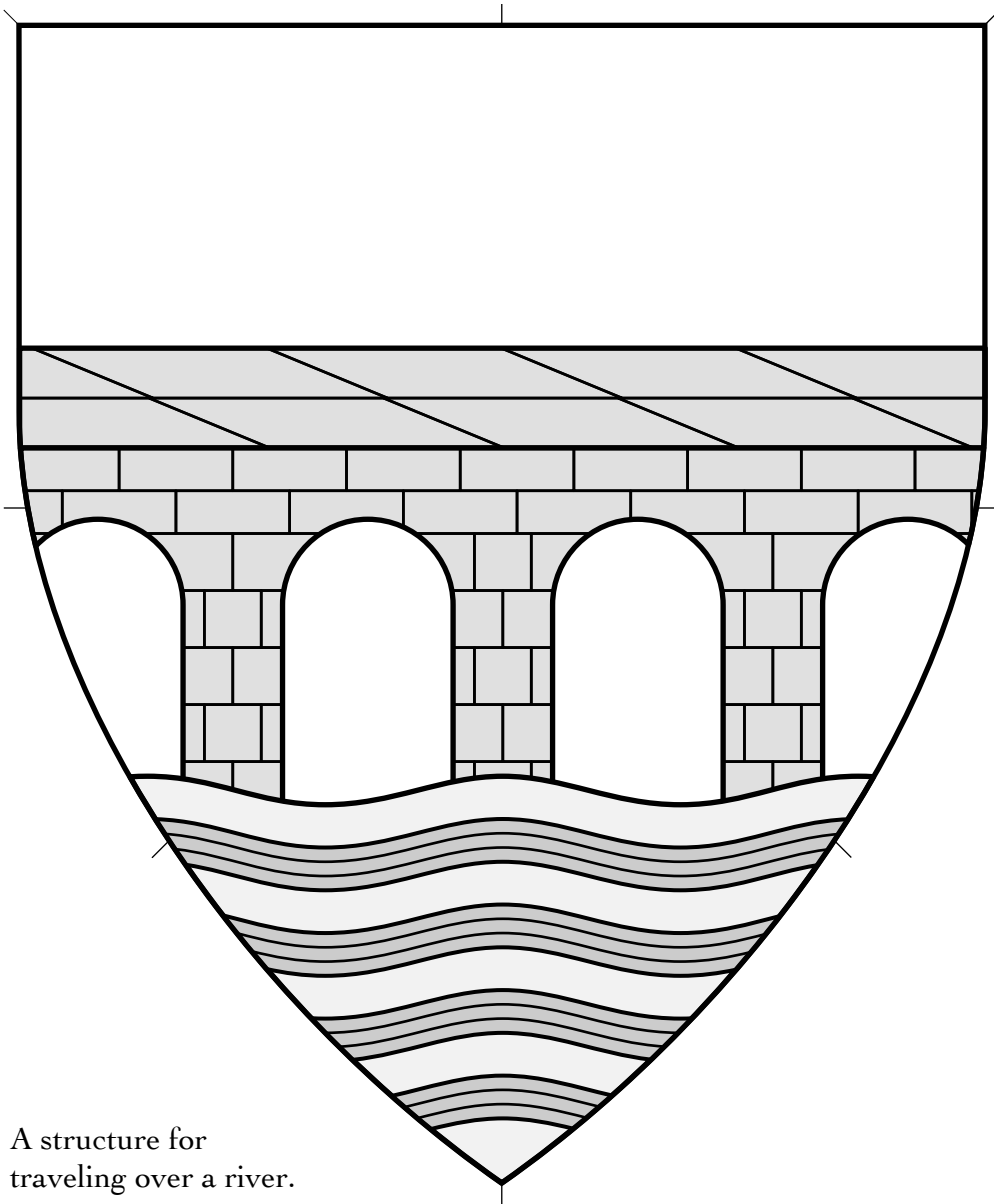

A structure for
traveling over a river.

Default orientation: fesswise. No proper coloration.

Source: Nobleza del Andaluzia. Artist unknown. (Arms of Guadiana, folio 164v.)

Bridge Throughout of Four Arches Issuant from a Ford 🍷 17.51

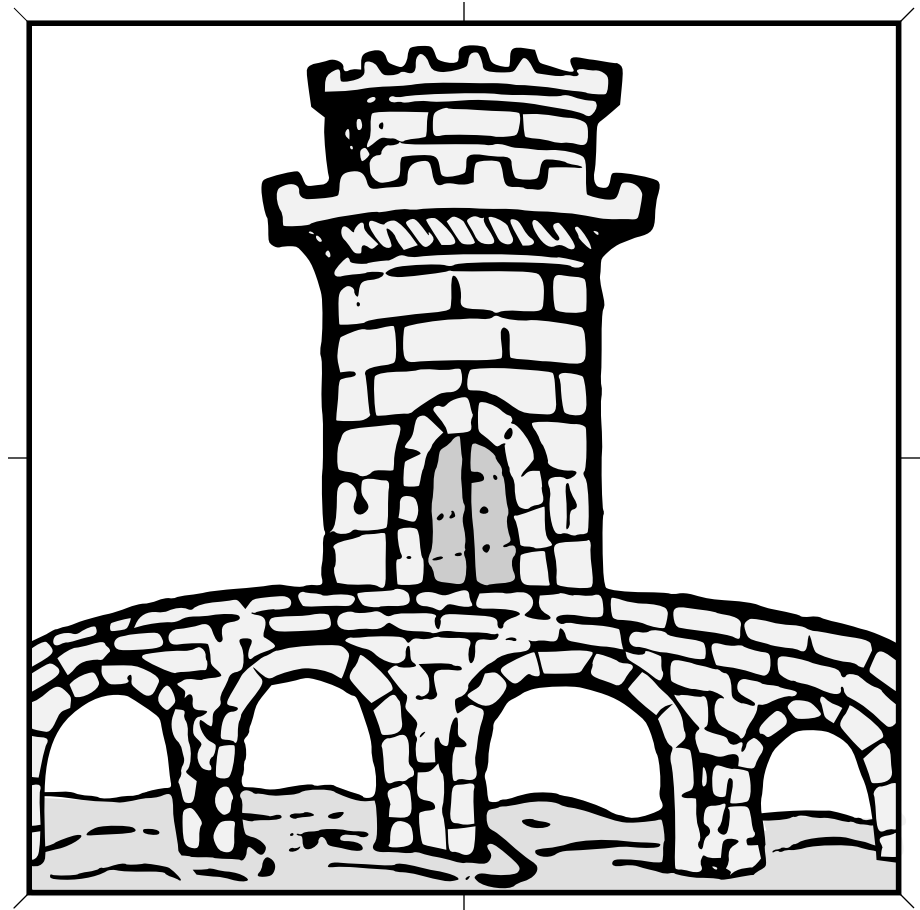
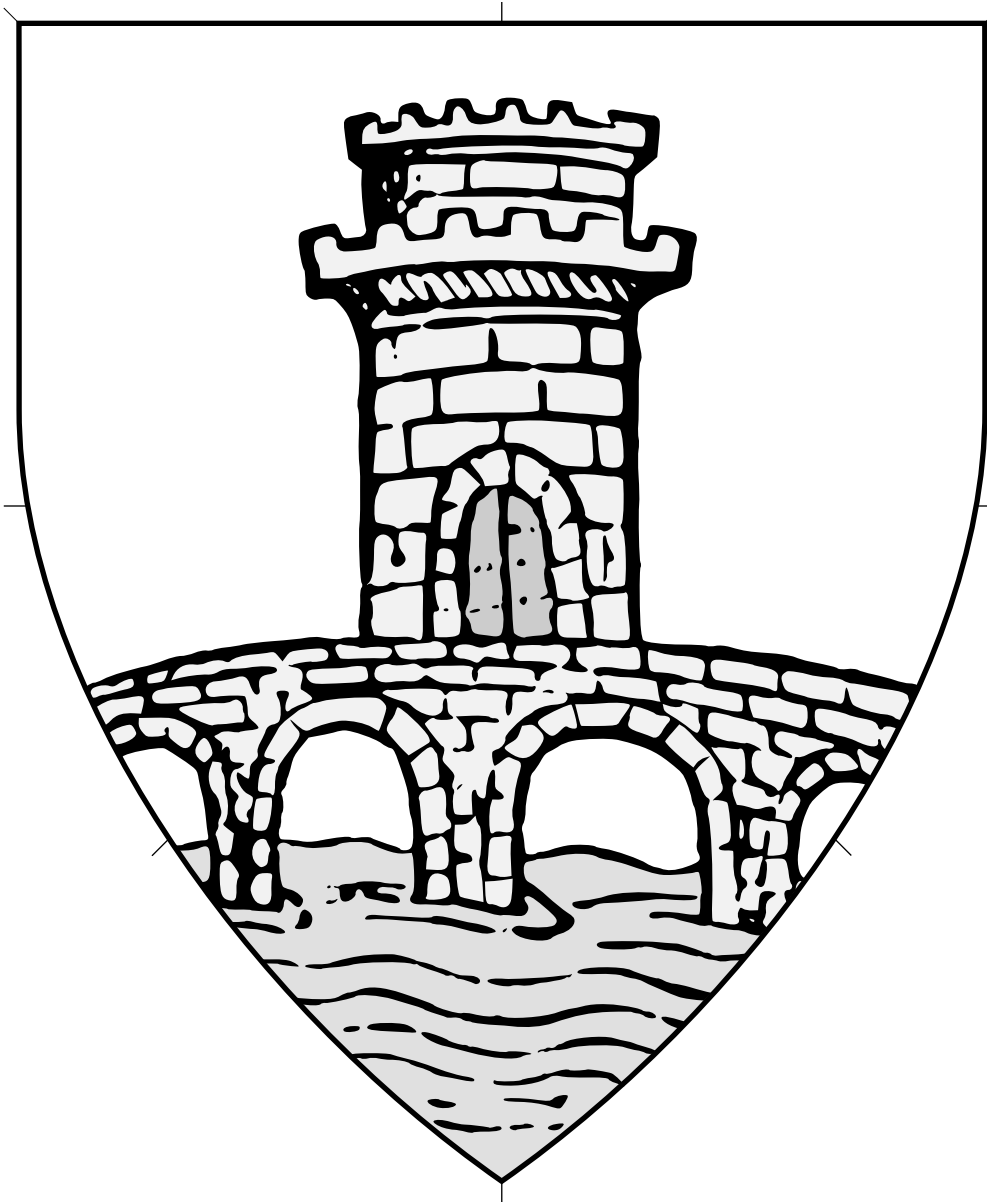

A structure for traveling over a river. Default orientation: fesswise. No proper coloration.

Source: Nobleza del Andaluzia. Artist unknown. (Arms of Aranda II, folio 279v.)

Bridge Throughout of Four Arches and One Tower 17.52

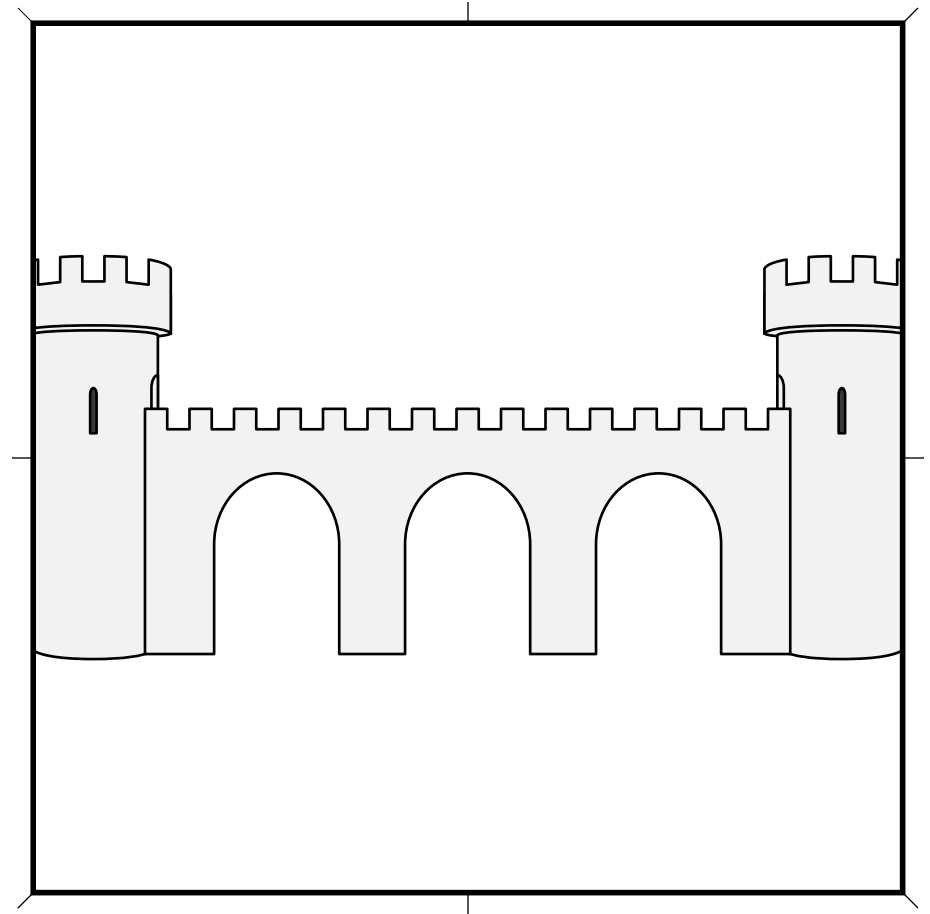
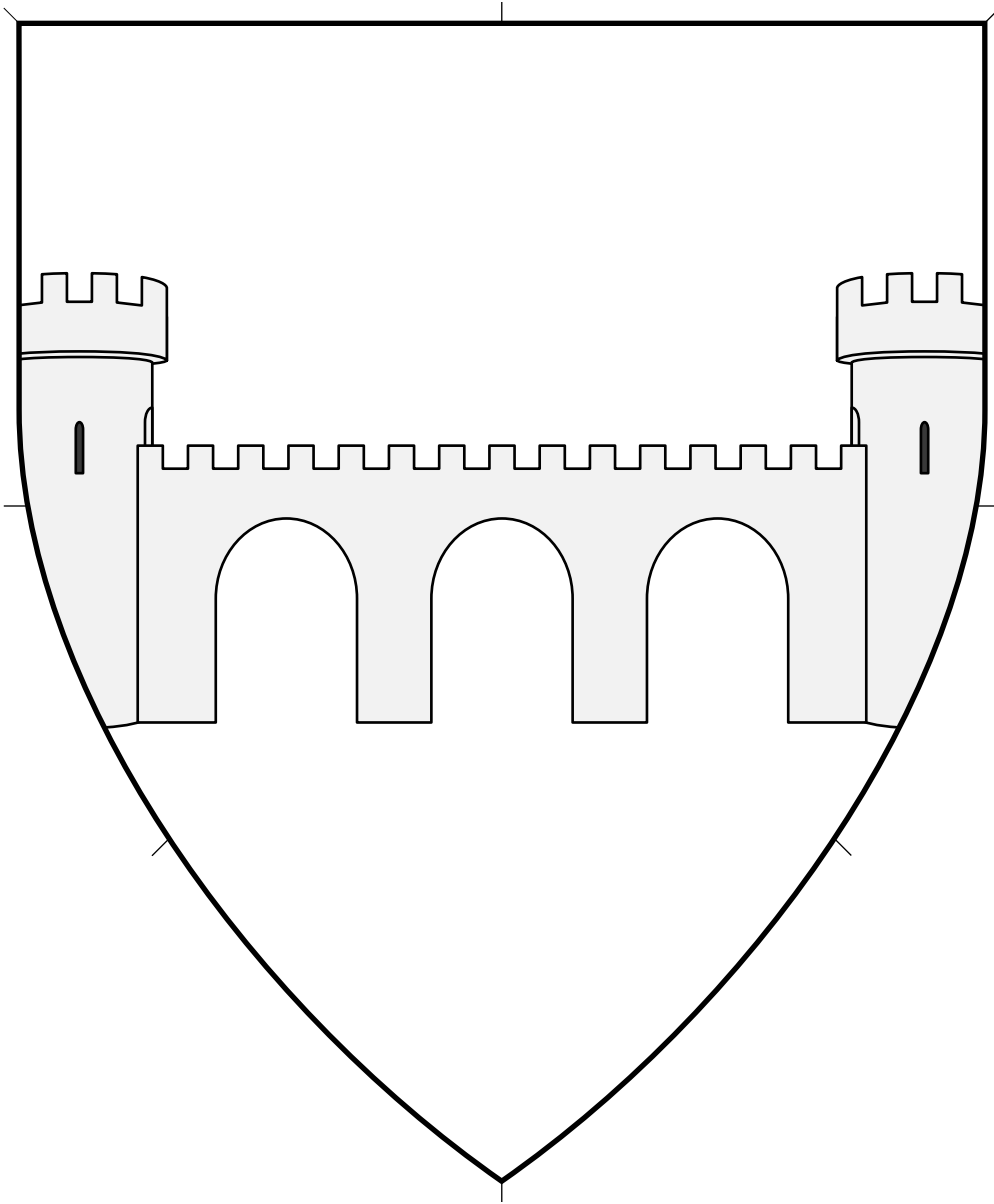

A structure for traveling over a river.

Default orientation: fesswise. No proper coloration.

Bridge Throughout, Twin-Towered, Of Three Arches 17.53

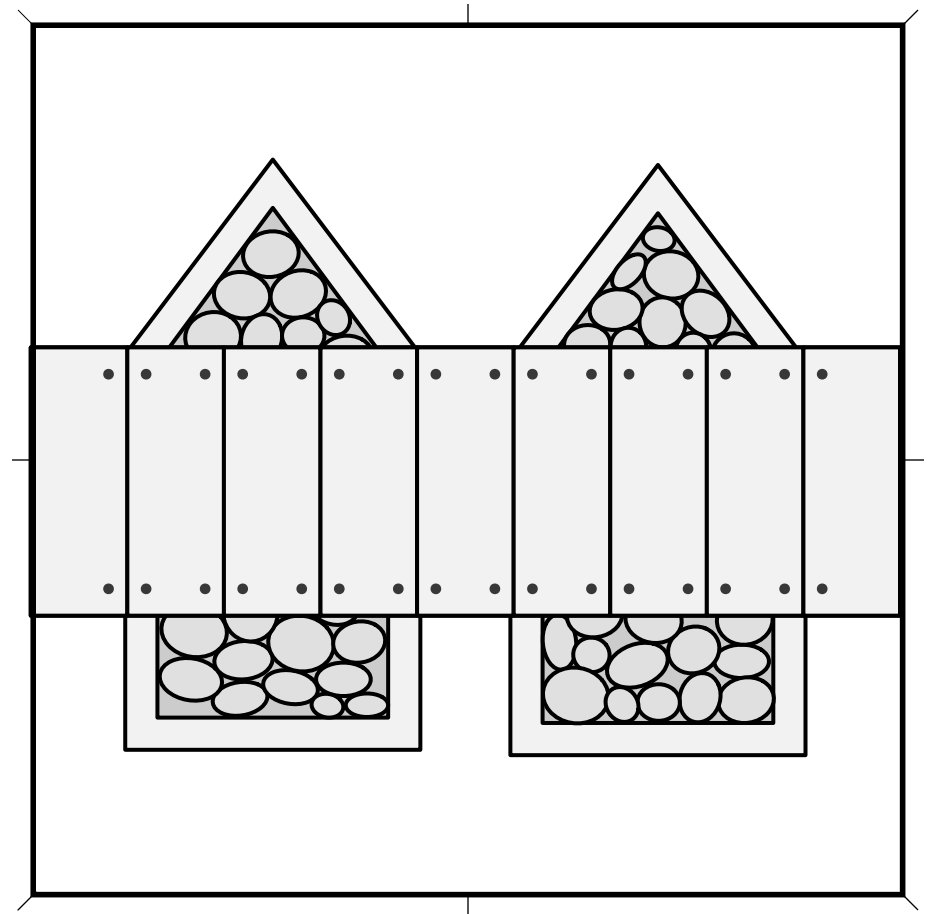
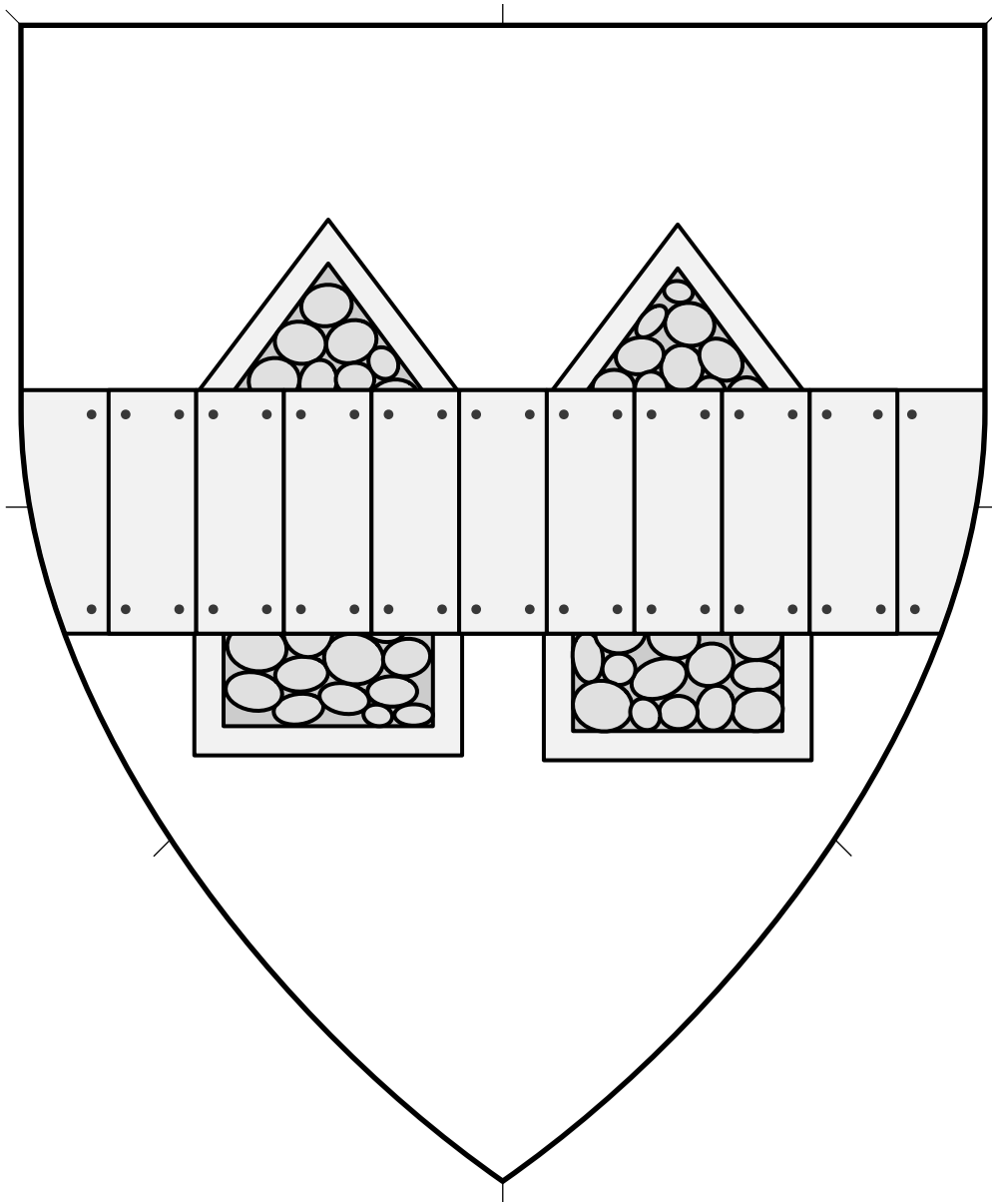

A structure for traveling over a river.

Default orientation: fesswise. No proper coloration.

Source: Sammelband Mehrerer Wappenbücher.
Artist unknown. (Folio 160r, arms of Innsbruck.)

Bridge From Overhead 🦉 17.54

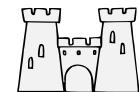
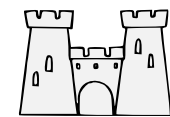
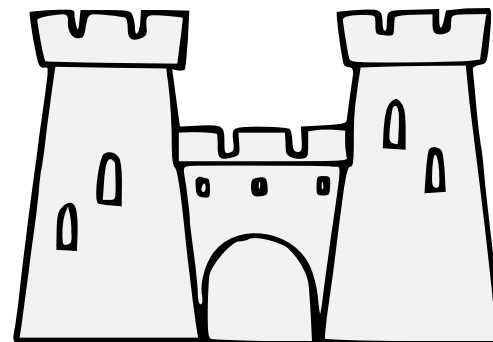
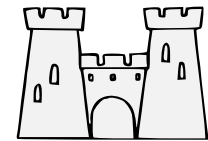
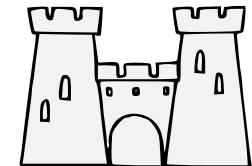
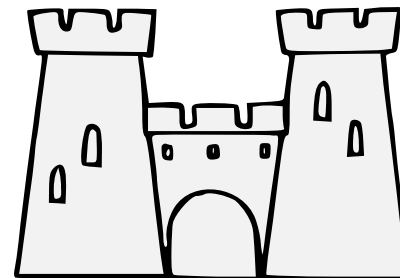
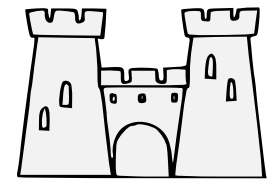
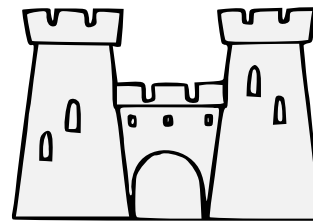
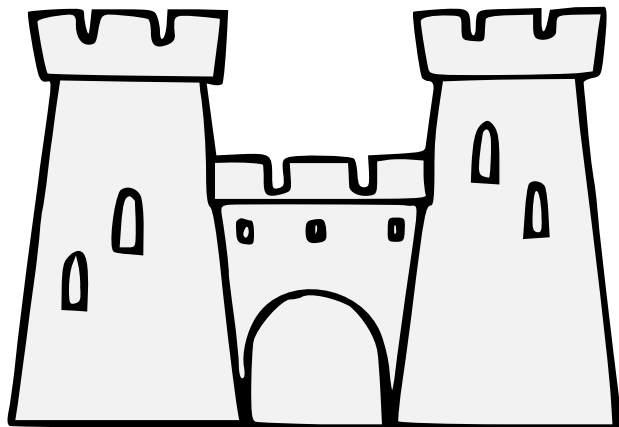
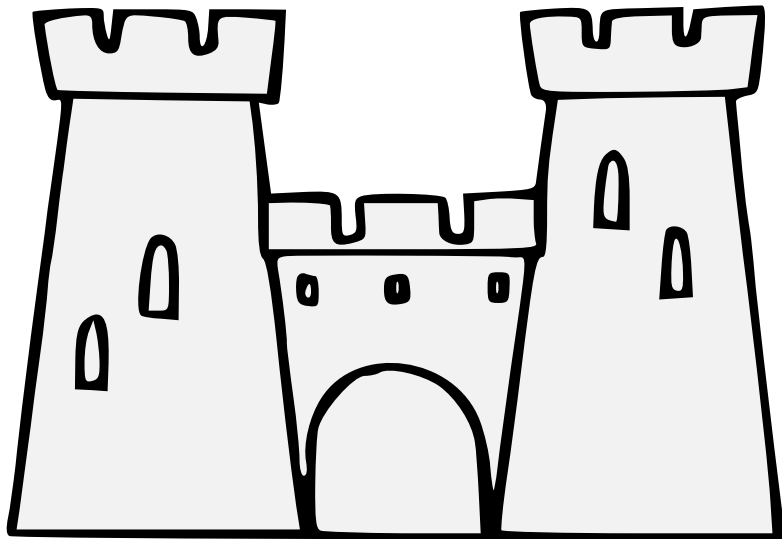

A fortified structure of towers joined by walls.

Default orientation: upright. Proper coloration: gray or argent stone.

Source: Pennsic Traceable Art. Artist: Roana d'Evreux (attributed).

Castle (1) 17.55

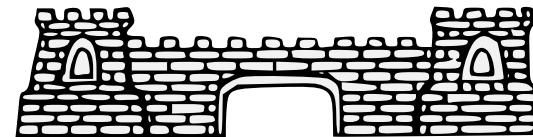
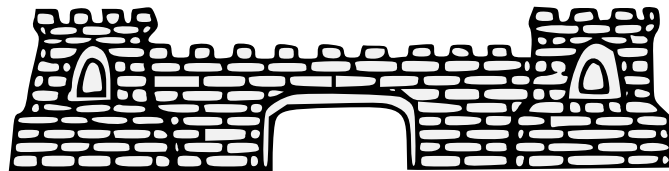
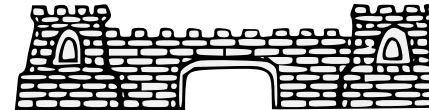
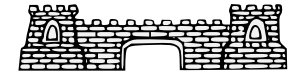
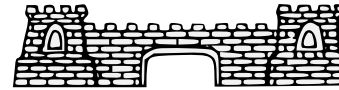
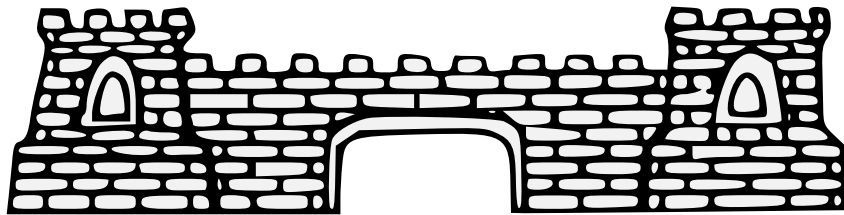

A fortified structure of towers joined by walls.

Default orientation: upright. Proper coloration: gray or argent stone.

Source: Pennsic Traceable Art. Artist: Kryss Kostarev.

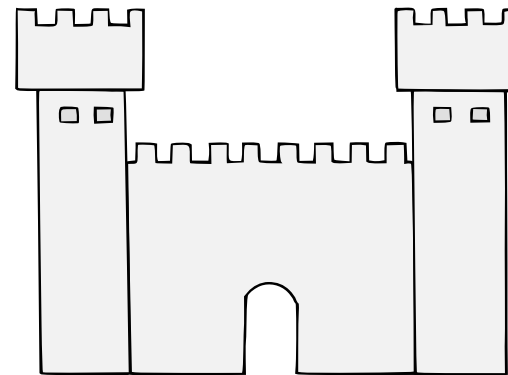
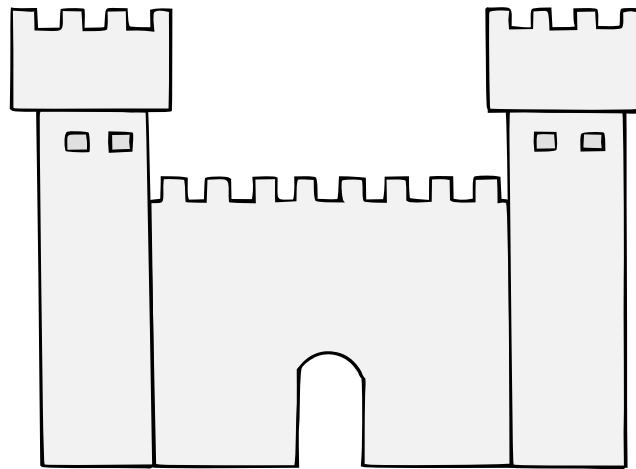
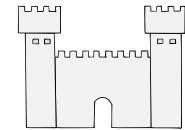
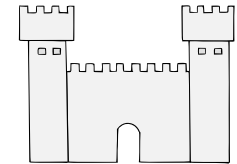
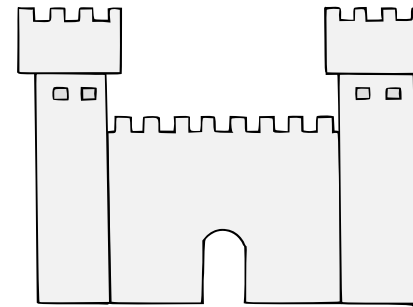
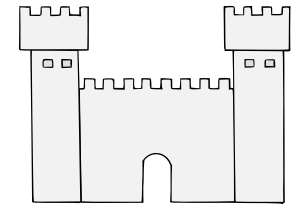
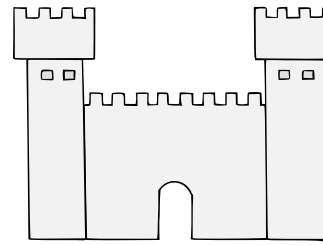
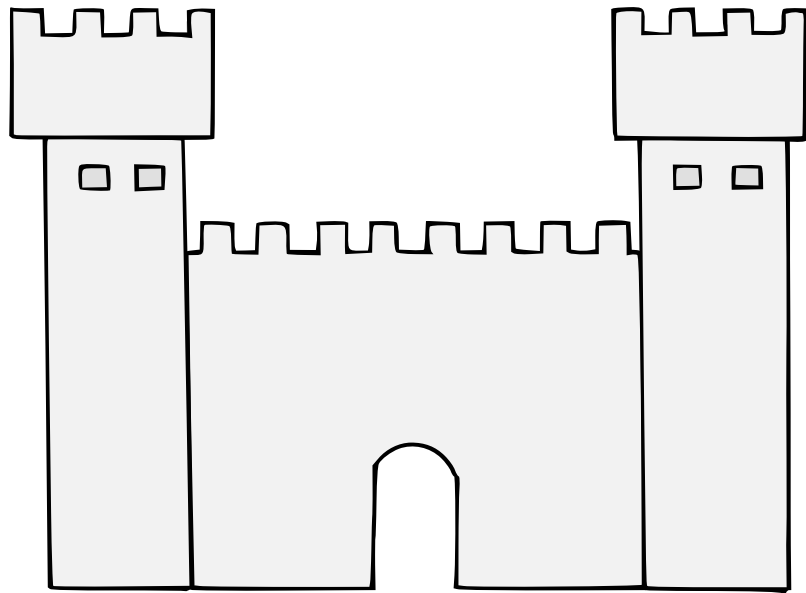

A fortified structure of towers joined by walls.

Default orientation: upright. Proper coloration: gray or argent stone.

Artist: Þórý Veðardóttir. License: CC BY-NC-SA; commercial use requires permission.

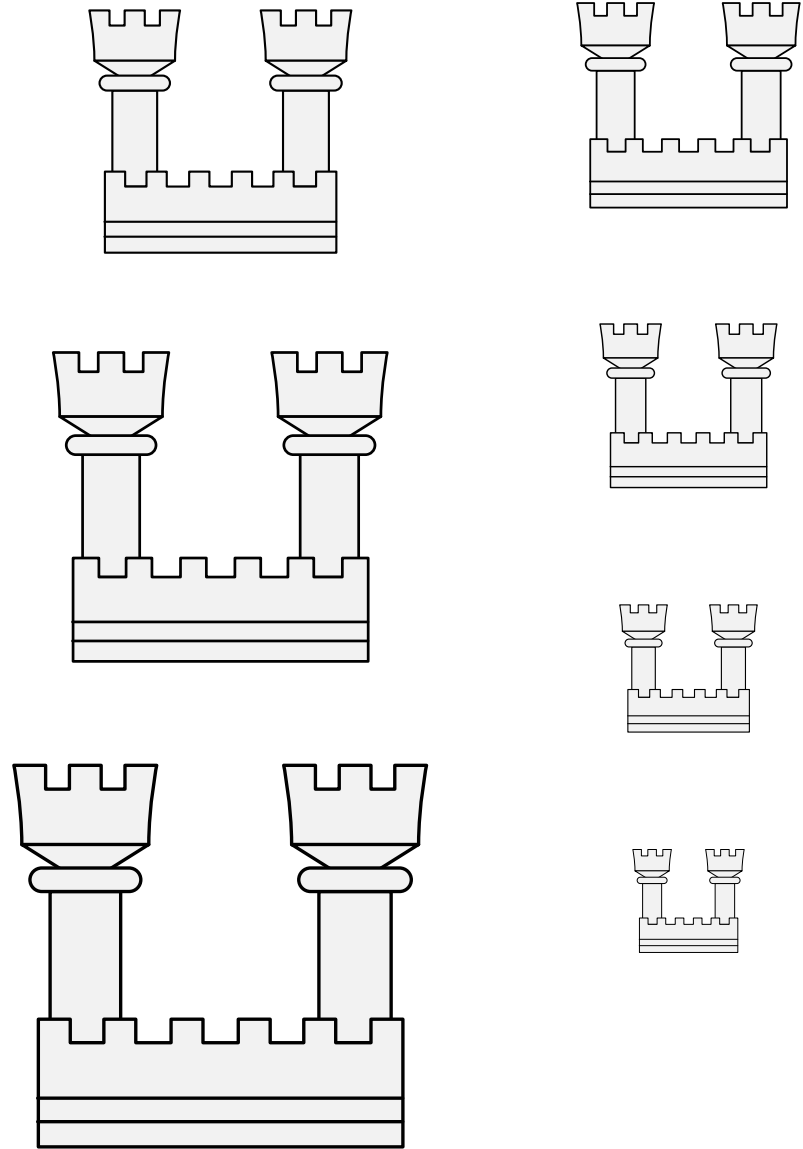
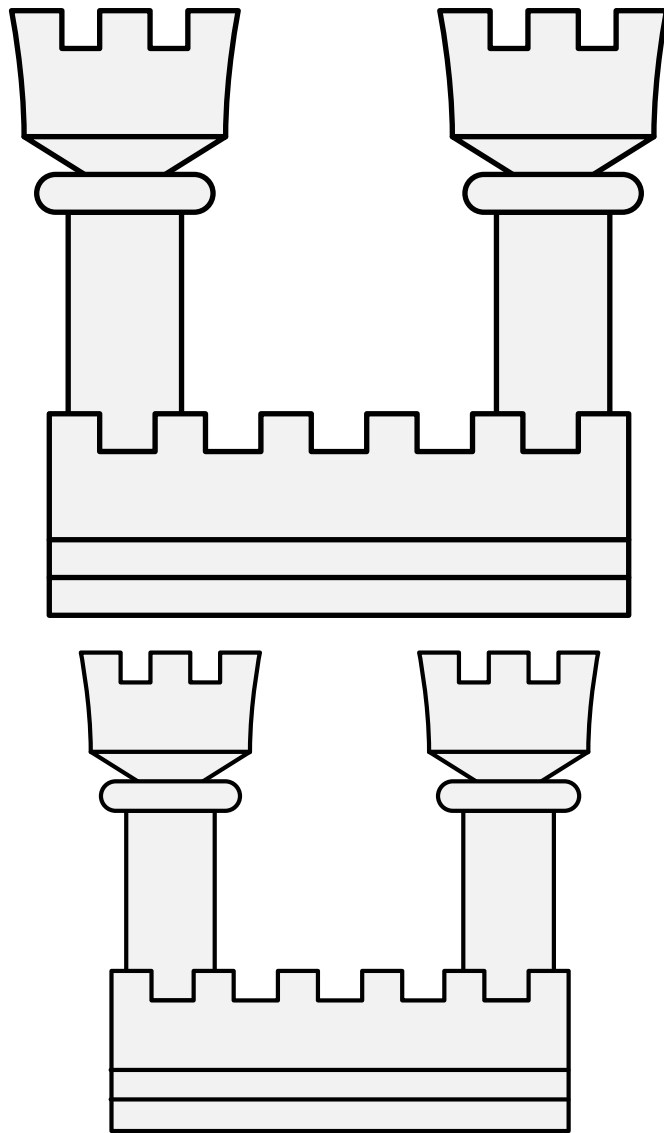

A fortified structure of towers joined by walls.
Default orientation: upright. Proper coloration: gray or argent stone.
Source: Aegidius Tschudi's Armorial. Artist unknown.

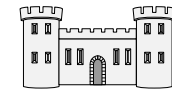
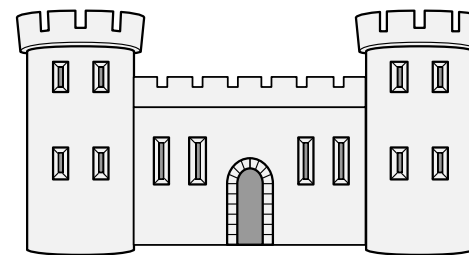
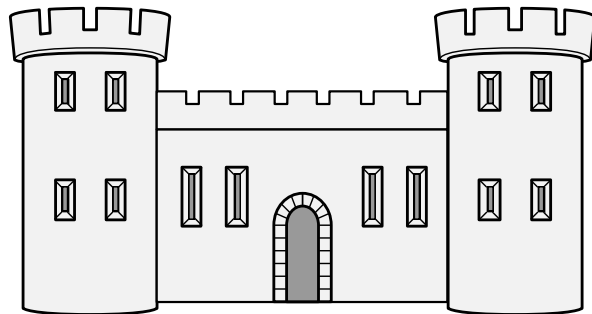
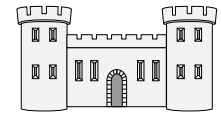
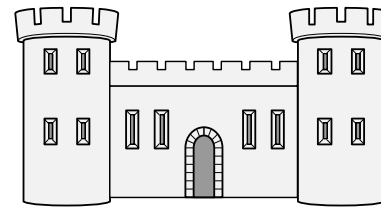
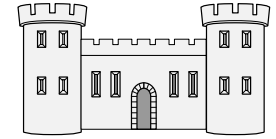
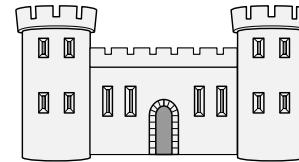
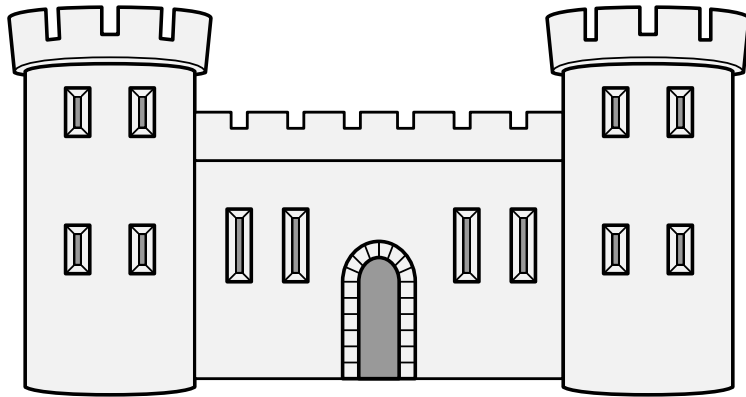

A fortified structure of towers joined by walls.

Default orientation: upright. Proper coloration: gray or argent stone.

Source: Opus Insignium Armorumque. Artist: Johann Weikhard von Valvasor.
Adapted by Mathghamhain Ua Ruadháin.

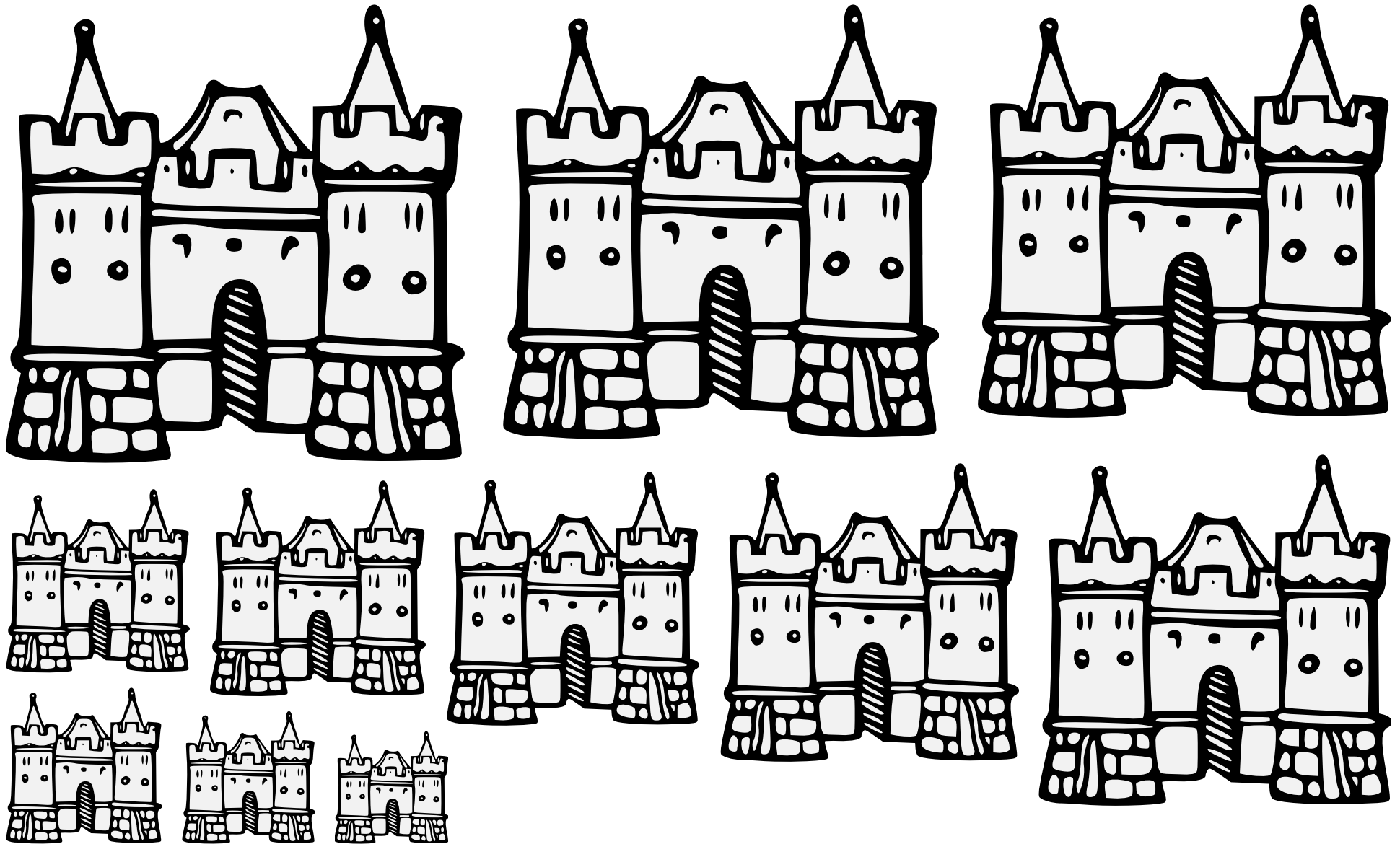

A fortified structure of towers joined by walls.

Default orientation: upright. Proper coloration: gray or argent stone.

Source: Catalogue des Nobles Admiraulx de France. Artist unknown. (Folio 3r.)

Castle (6) 17.60

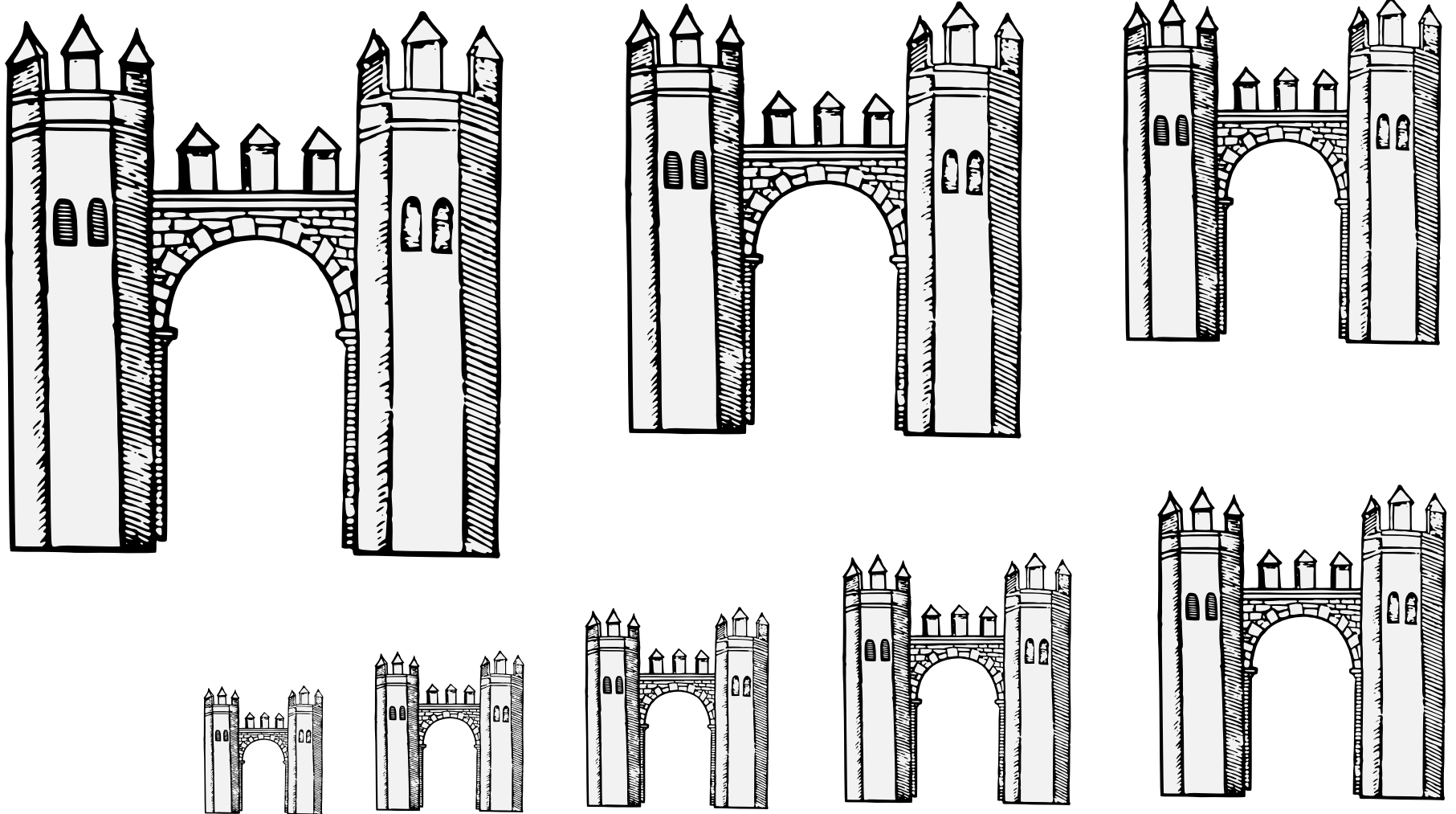

A fortified structure of towers joined by walls.

Default orientation: upright. Proper coloration: gray or argent stone.

Source: Nobleza del Andaluzia. Artist unknown.
(Arms of the city of Baeca, folio 65r.)

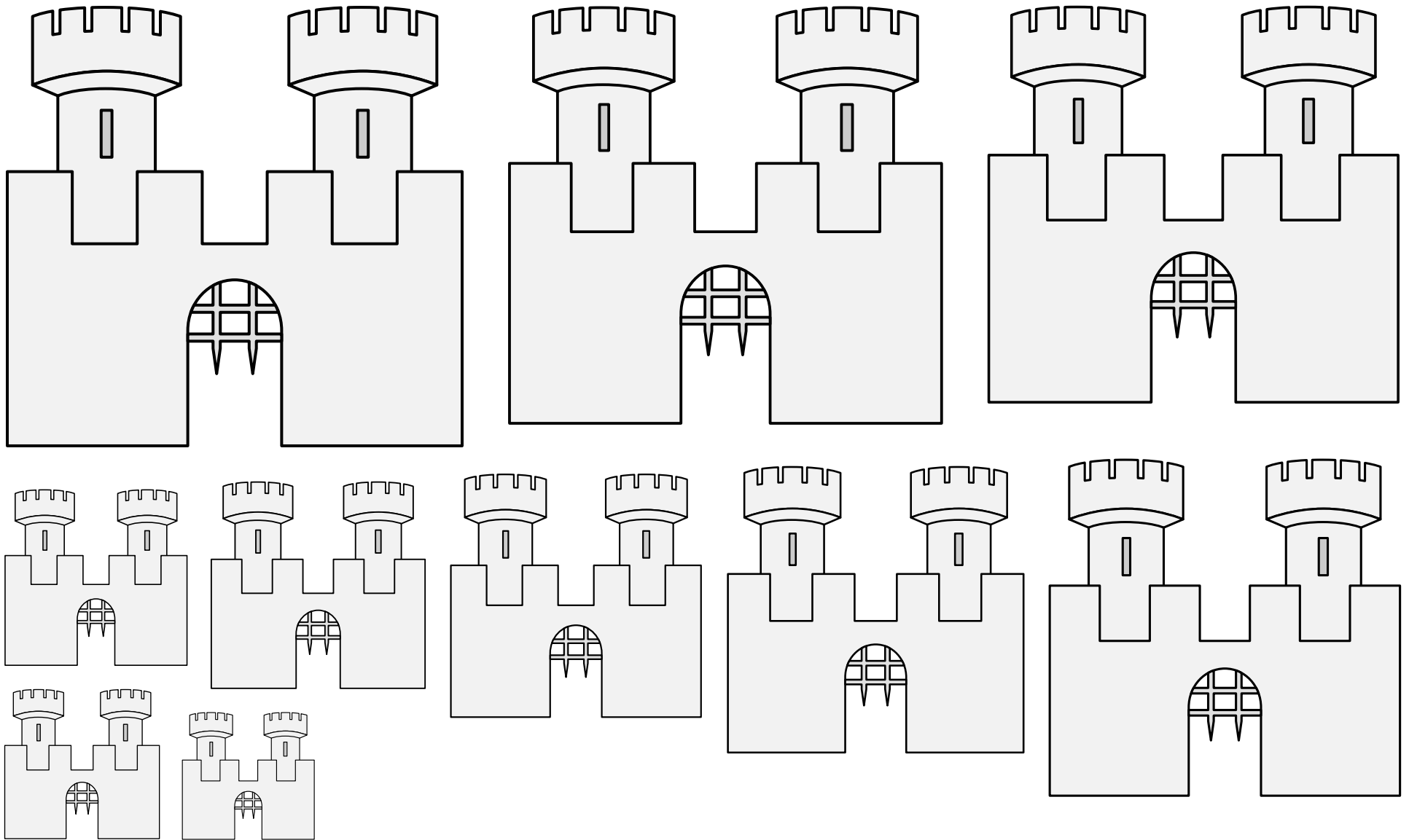

A fortified structure of towers joined by walls.

Default orientation: upright. Proper coloration: gray or argent stone.

Source: Le Grand Armorial Équestre de la Toison d'Or.
Artist unknown. Adapted by Mathghamhain Ua Ruadháin. (Page 51.)

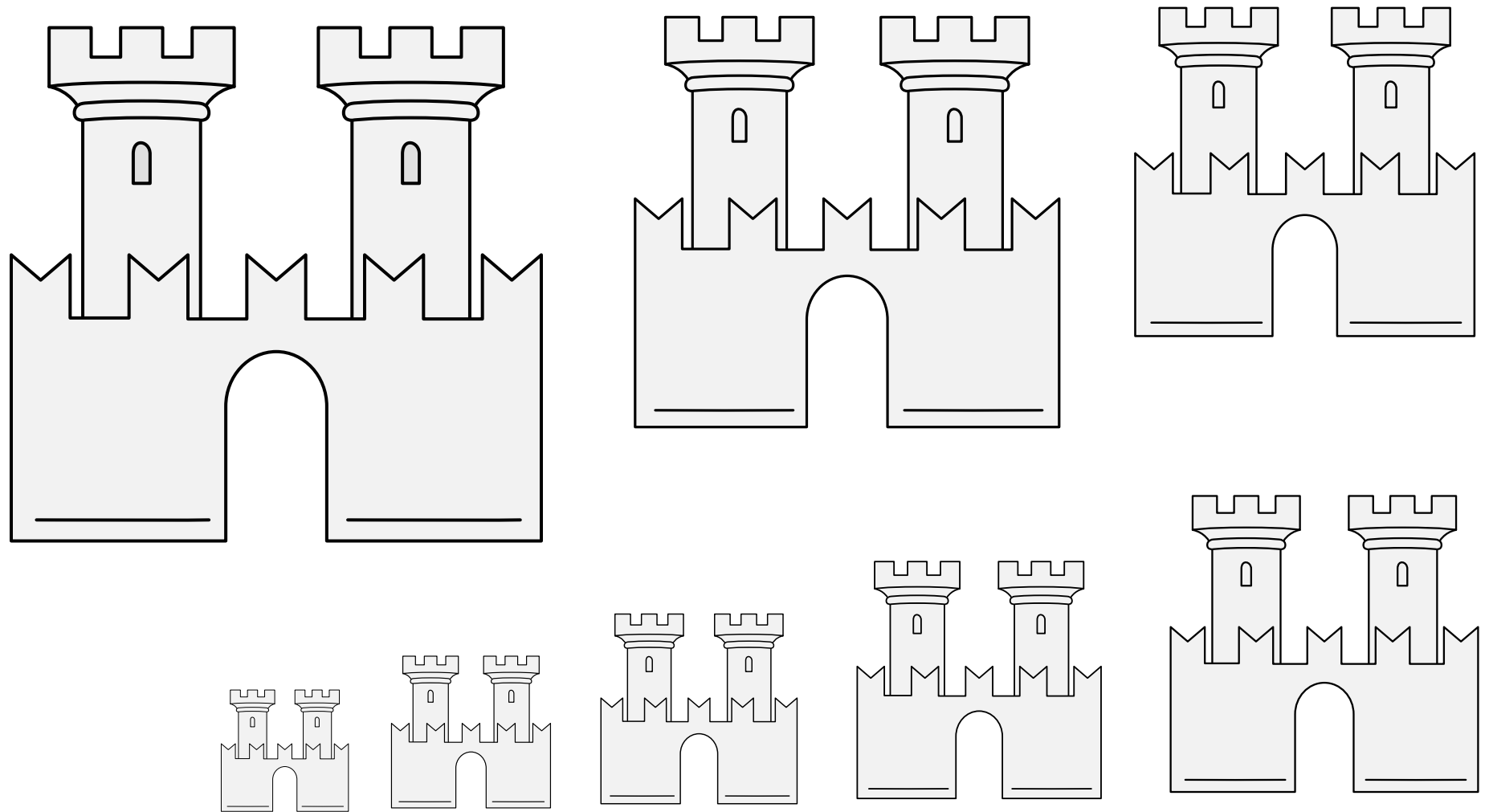

A fortified structure of towers joined by walls.

Default orientation: upright. Proper coloration: gray or argent stone.

Source: Wappenbuch der Arlberg-Bruderschaft.

Artist: Vigil Raber. (Page 128.)

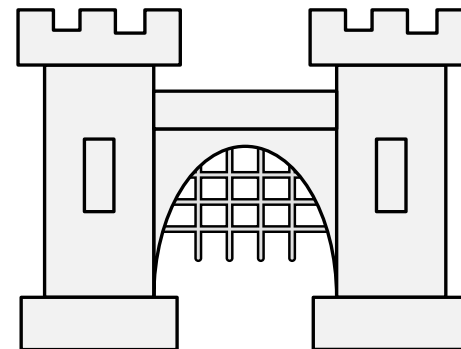
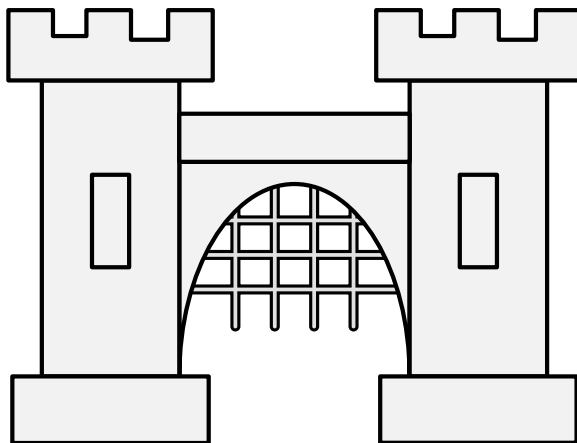
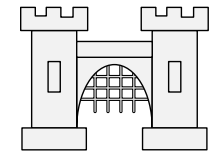
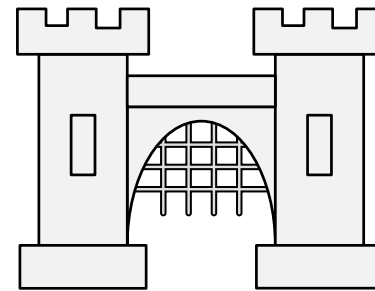
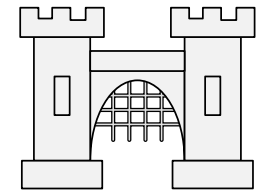
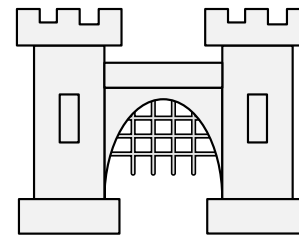
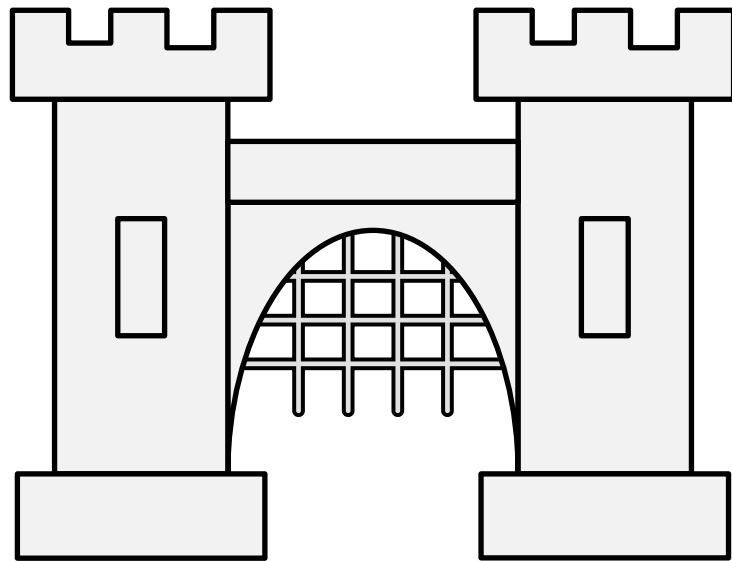

A fortified structure of towers joined by walls.

Default orientation: upright. Proper coloration: gray or argent stone.

Source: Des Kaiserlichen Kammergerichts zu Speier Kammerrichter. Artist unknown. (Folio 5r.)

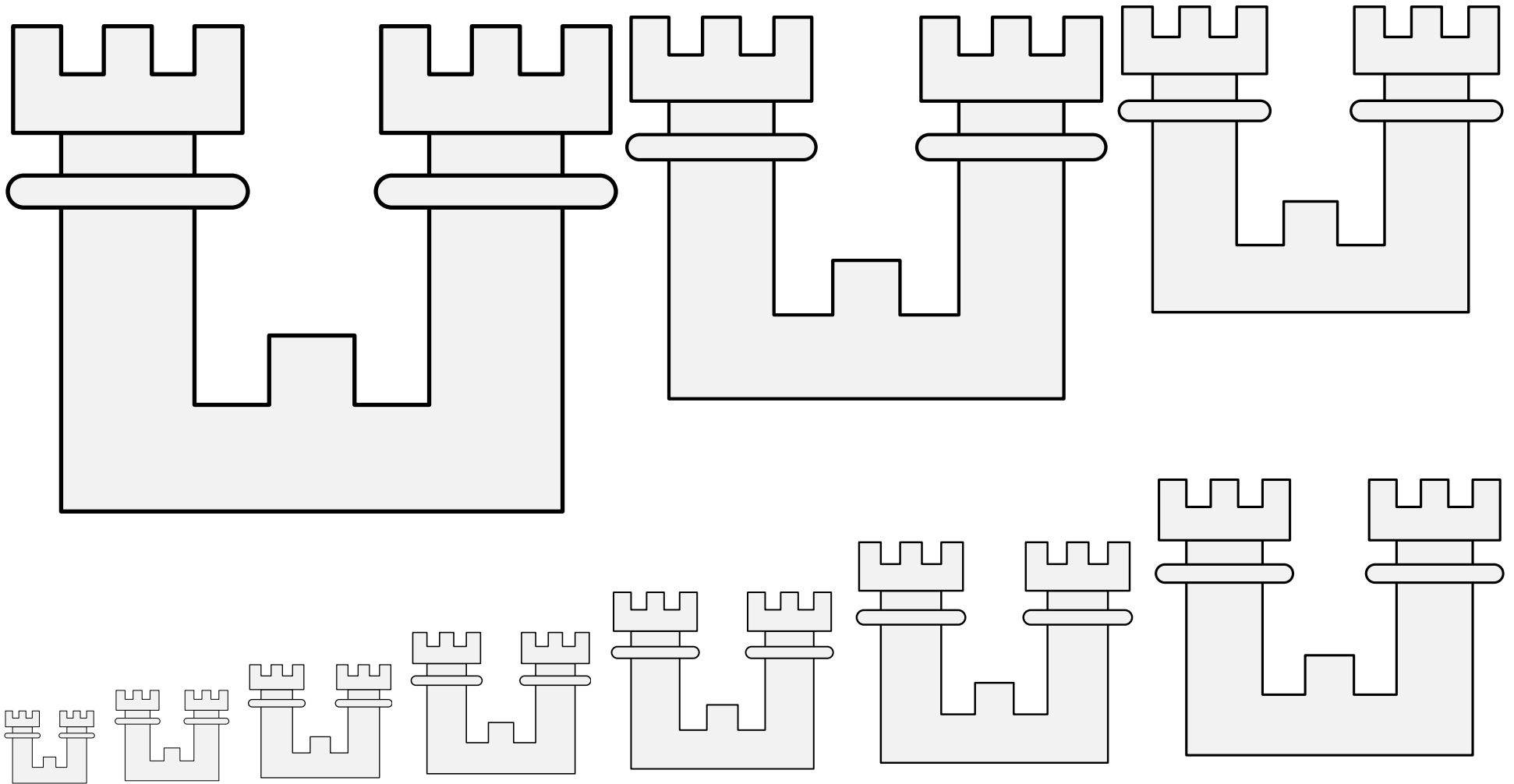

A fortified structure of towers joined by walls.

Default orientation: upright. Proper coloration: gray or argent stone.

Source: Anton Tirol's Wappenbuch. Artist: Anton Tirol. (Folio 95v.)

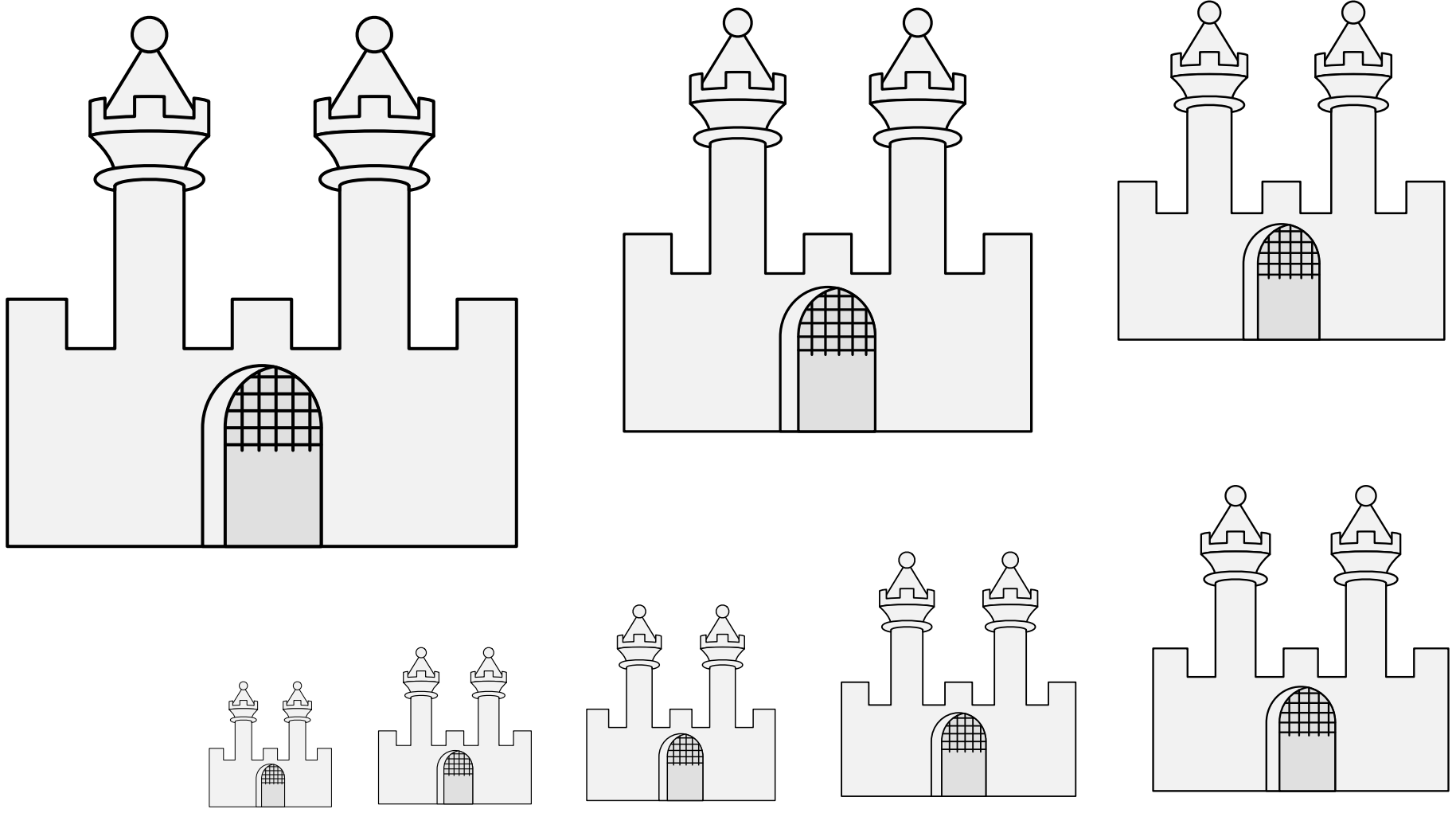

A fortified structure of towers joined by walls.
Default orientation: upright. Proper coloration: gray or argent stone.
Source: Wernigerode Armorial. Artist unknown. (Page 511.)

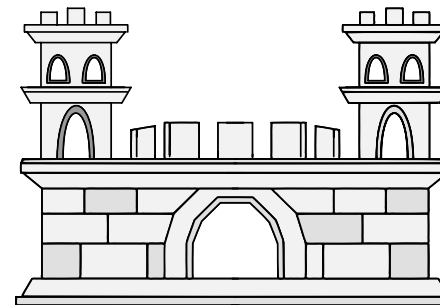
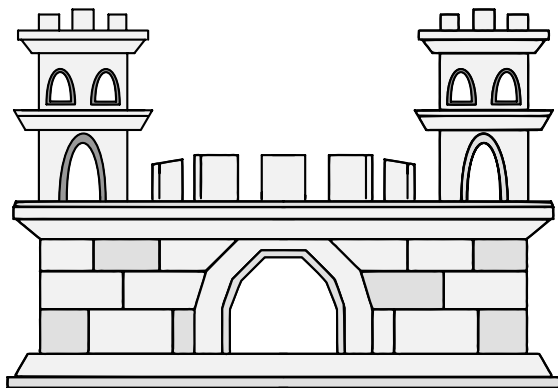
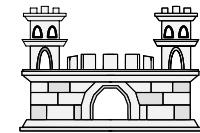
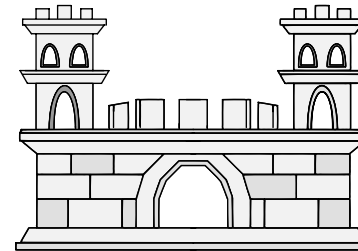
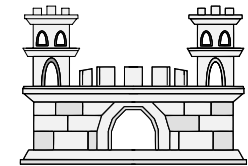
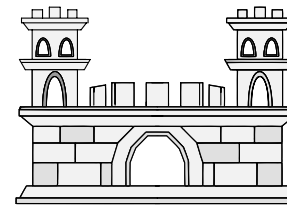
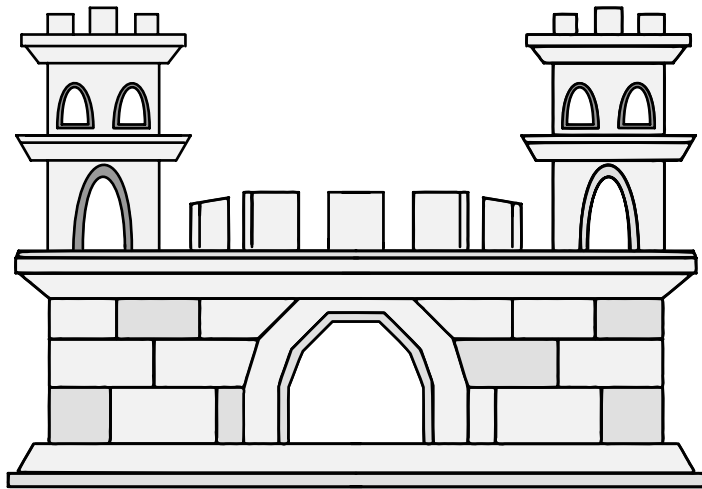

A fortified structure of towers joined by walls.

Default orientation: upright. Proper coloration: gray or argent stone.

Source: Stemmario Trivulziano. Artist: Gian Antonio da Tradate. (Page 131.)

Adapted by Wylet Fraser.

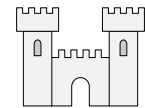
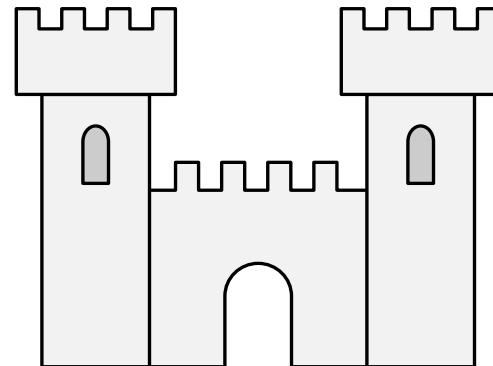
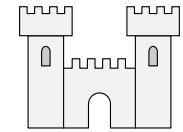
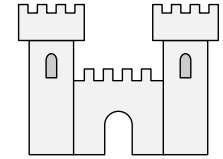
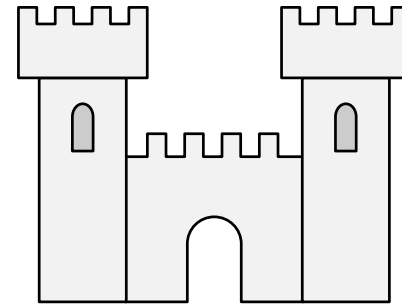
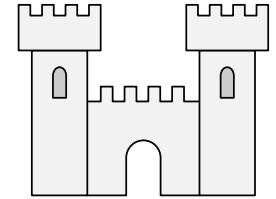
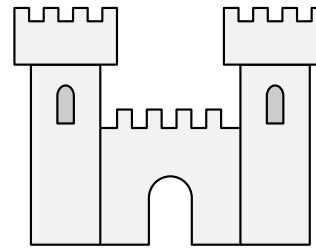
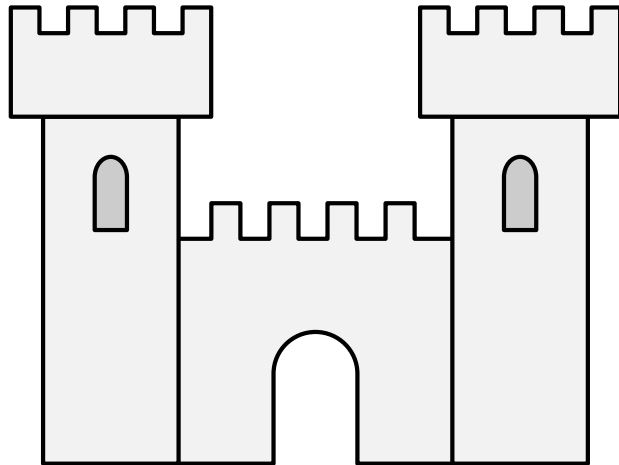
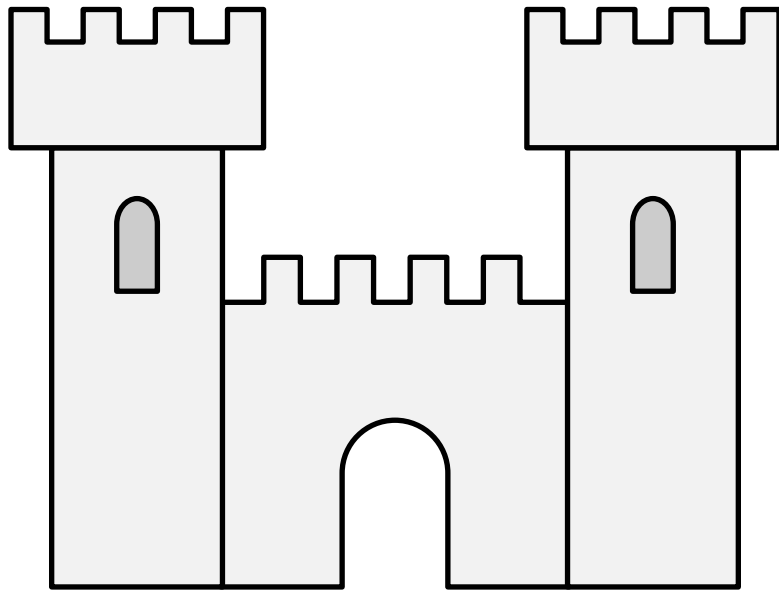

A fortified structure of towers joined by walls.
Default orientation: upright. Proper coloration: gray or argent stone.

Castle (14) 17.68

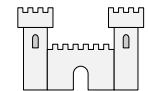
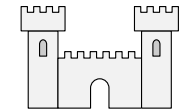
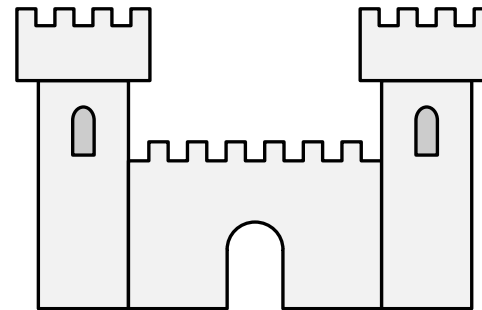
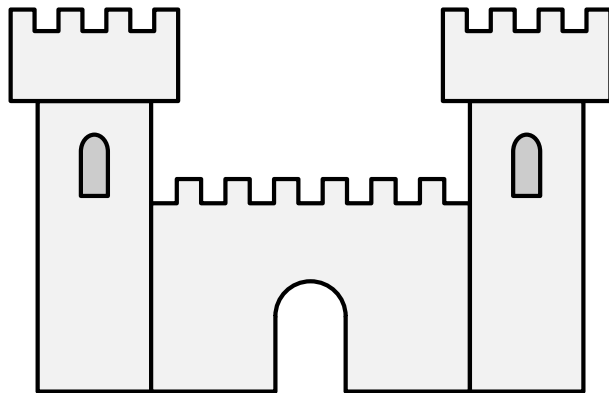
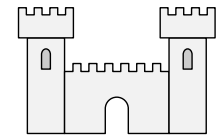
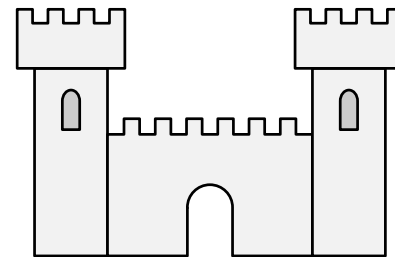
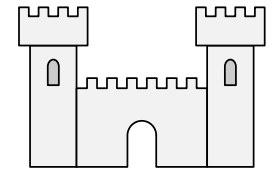
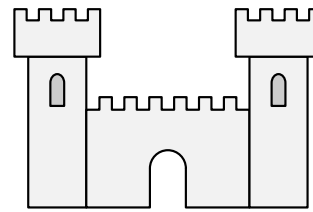
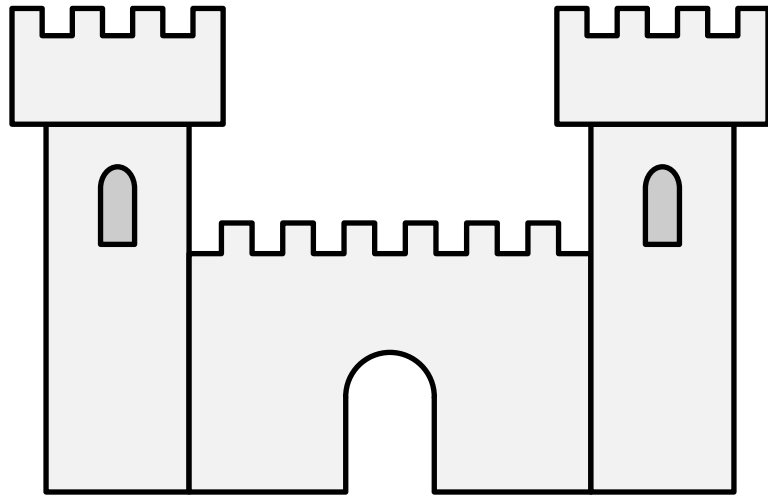

A fortified structure of towers joined by walls.
Default orientation: upright. Proper coloration: gray or argent stone.

Castle (15) 17.69

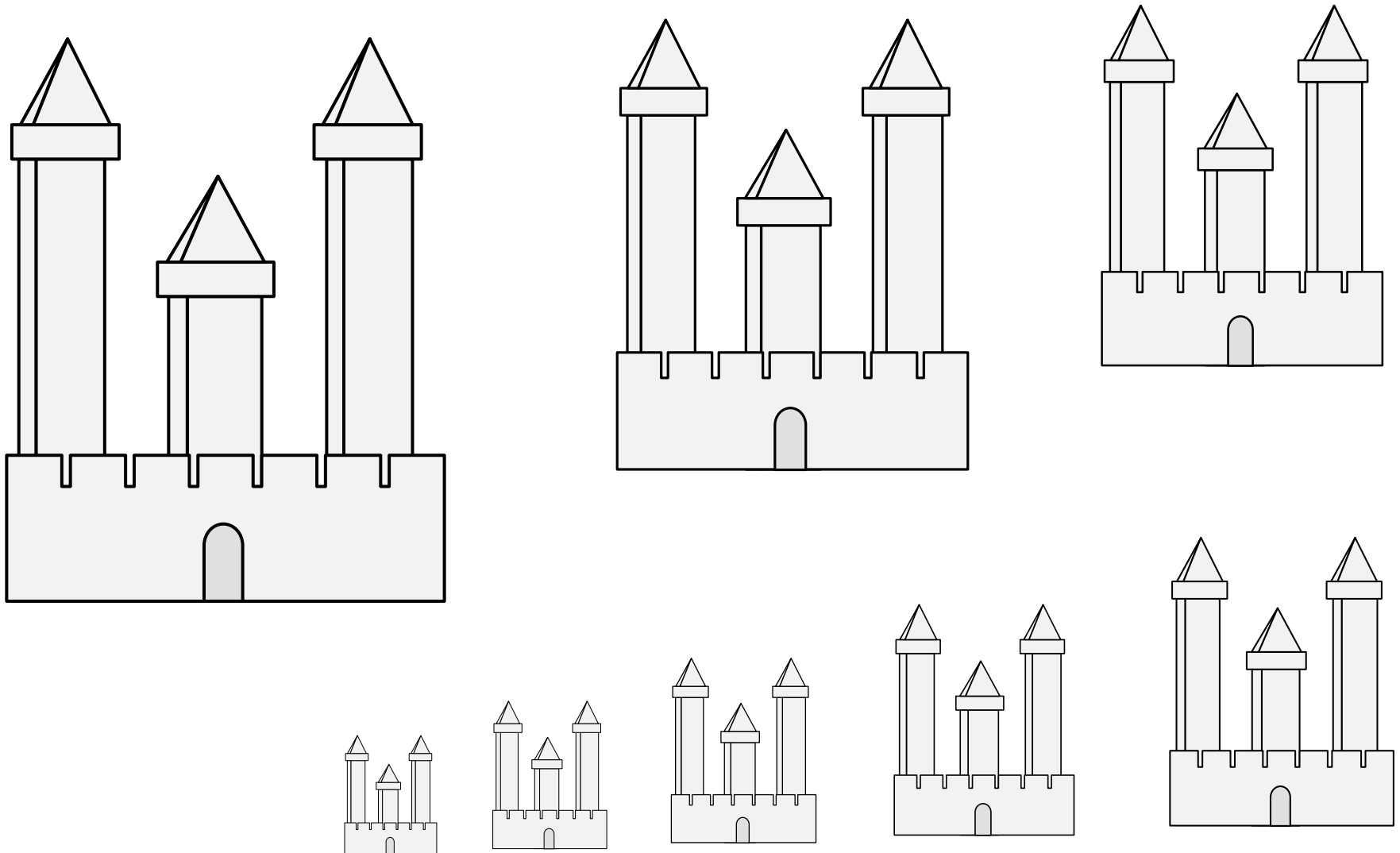

A group of non-military buildings enclosed by a wall.
Default orientation: upright. No proper coloration.
Source: Rylands MS 2. Artist unknown. (Page 43.)



A fortified structure of towers joined by walls.

Default orientation: upright. Proper coloration: gray or argent stone.

Source: Stemmario Trivulziano. Artist: Gian Antonio da Tradate.
(Arms of de Regola, p 305.)

Castle of One Tower 17.71

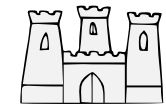
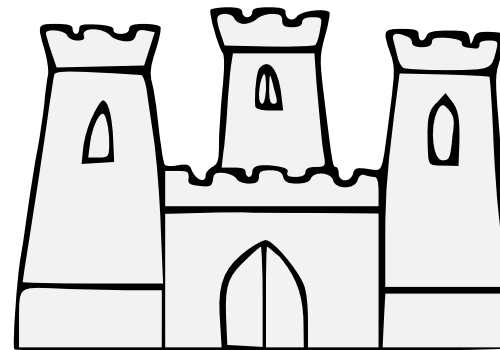
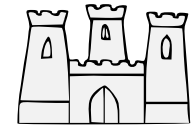
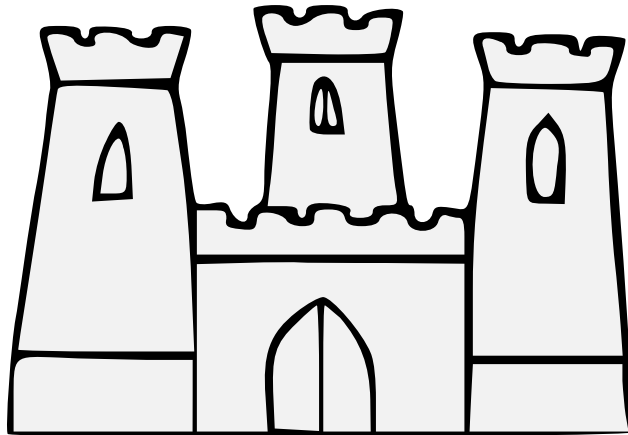
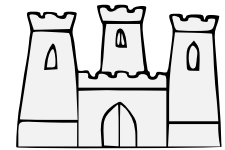
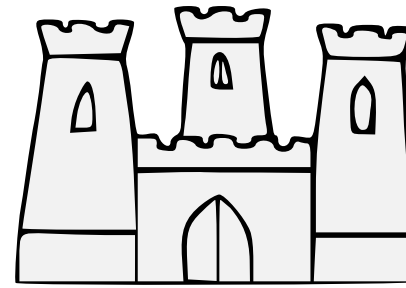
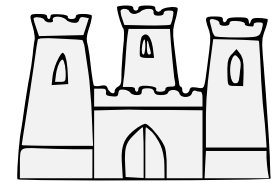
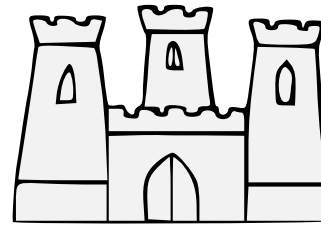
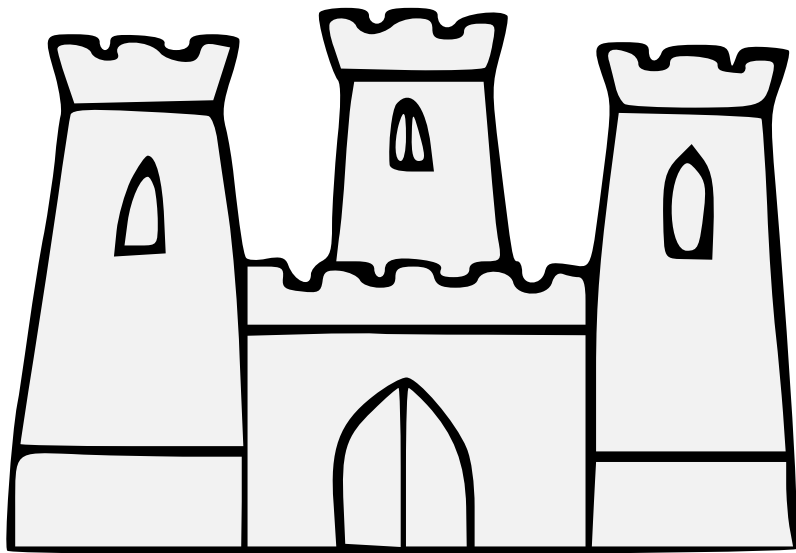

A fortified structure of towers joined by walls.

Default orientation: upright. Proper coloration: gray or argent stone.

Source: Pennsic Traceable Art.

Artist: Roana d'Evreux.

Castle of Three Towers (1) 17.72

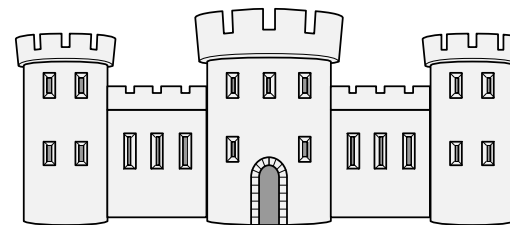
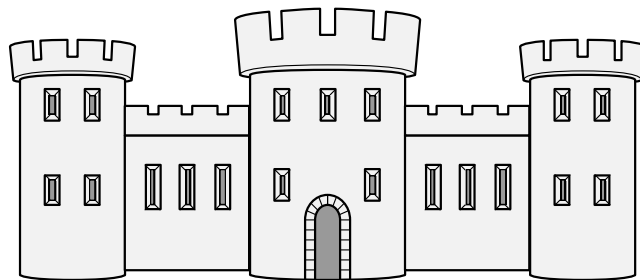
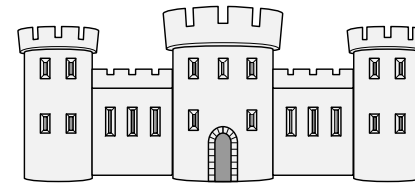
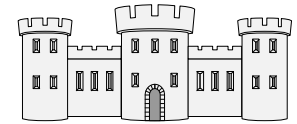
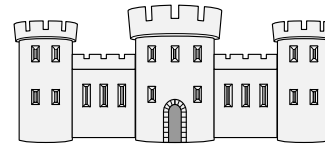
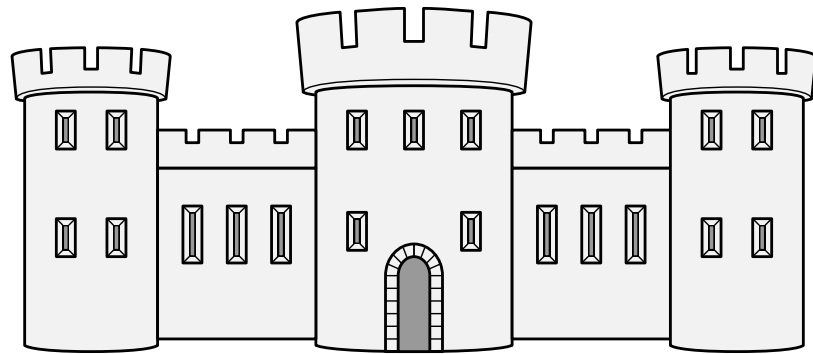

A fortified structure of towers joined by walls.

Default orientation: upright. Proper coloration: gray or argent stone.

Source: Opus Insignium Armorumque.

Artist: Johann Weikhard von Valvasor.

Adapted by Mathghamhain Ua Ruadháin.

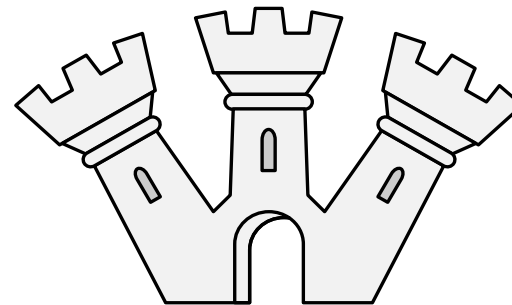
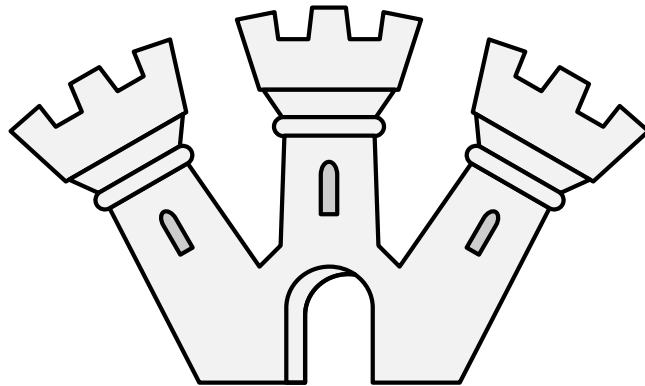
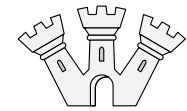
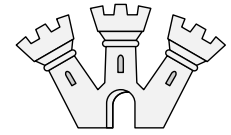
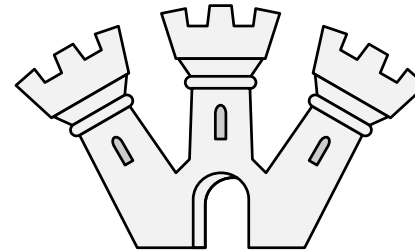
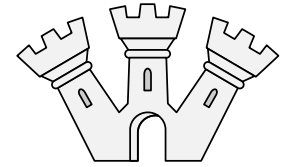
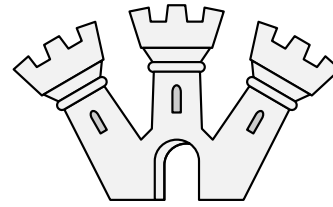
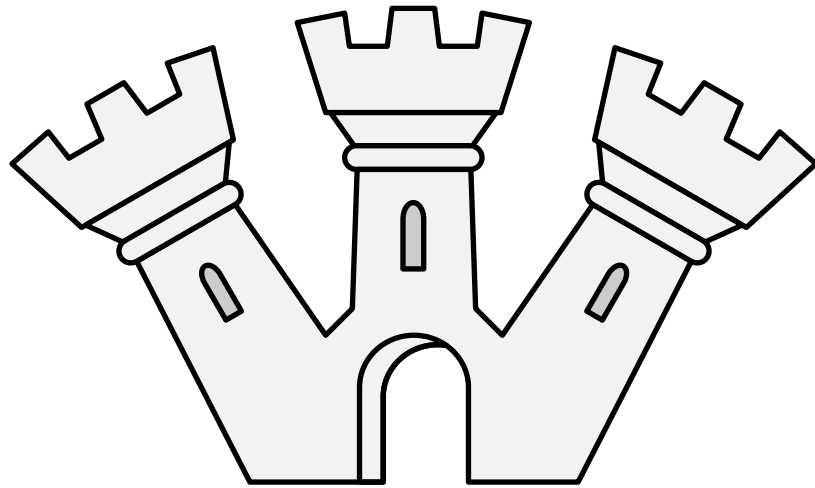

A fortified structure of towers joined by walls.

Default orientation: upright. Proper coloration: gray or argent stone.

Source: Chronicle of the Council of Constance.

Artist unknown. (Folio 143v.)

Castle of Three Towers (3) 17.74

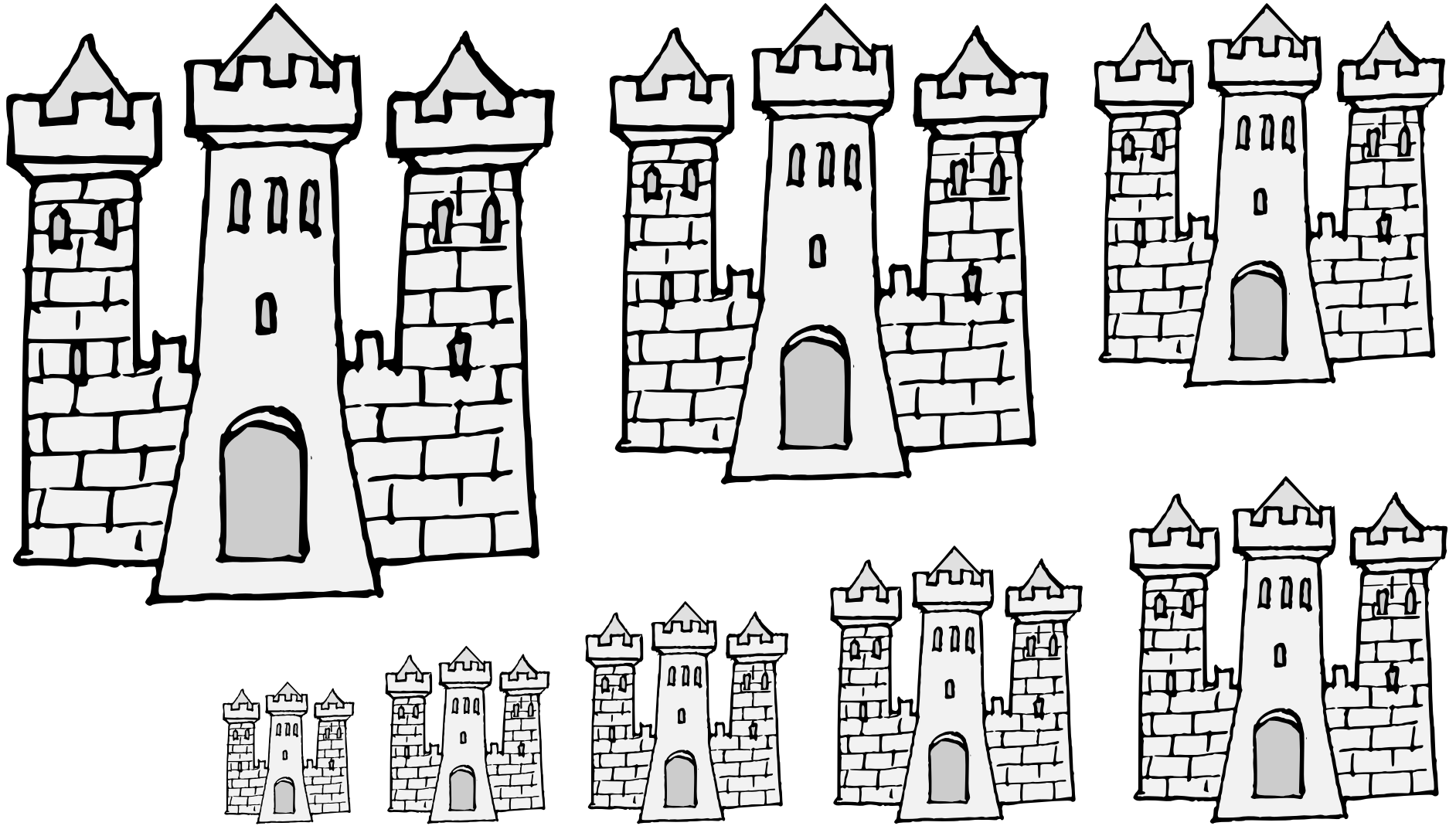

A fortified structure of towers joined by walls.

Default orientation: upright. Proper coloration: gray or argent stone.

Source: Sammelband Mehrerer Wappenbücher.

Artist unknown. (Folio 160r.)

Castle of Three Towers (4) 17.75

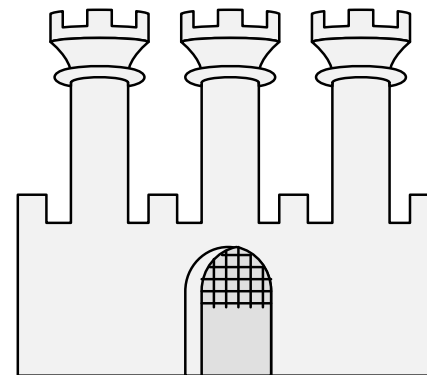
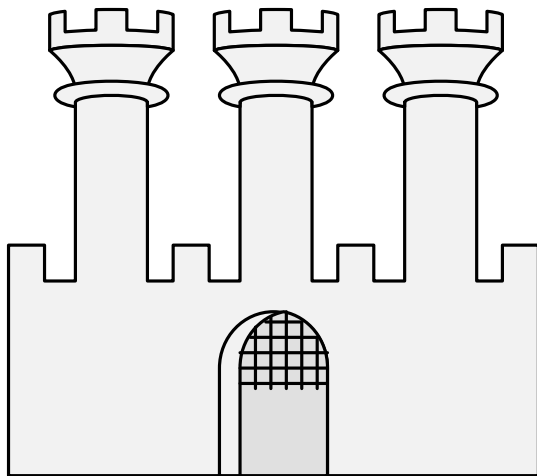
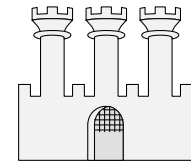
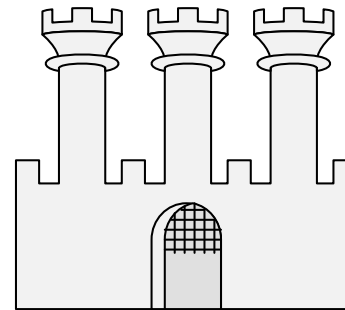
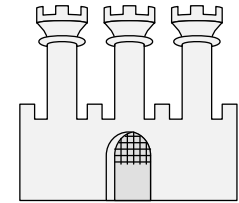
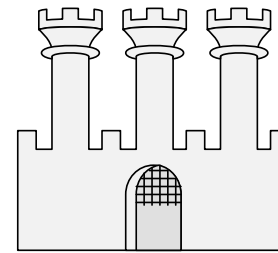
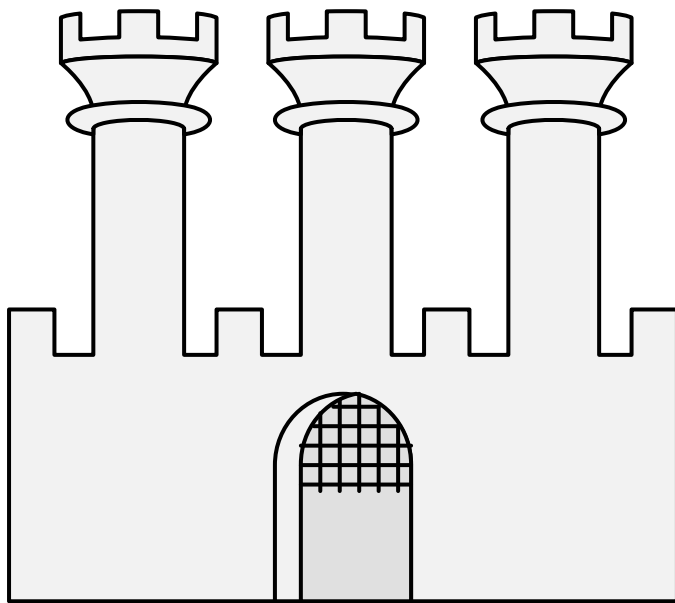

A fortified structure of towers joined by walls.

Default orientation: upright. Proper coloration: gray or argent stone.

Source: Wernigerode Armorial.

Artist unknown. (Page 511.)

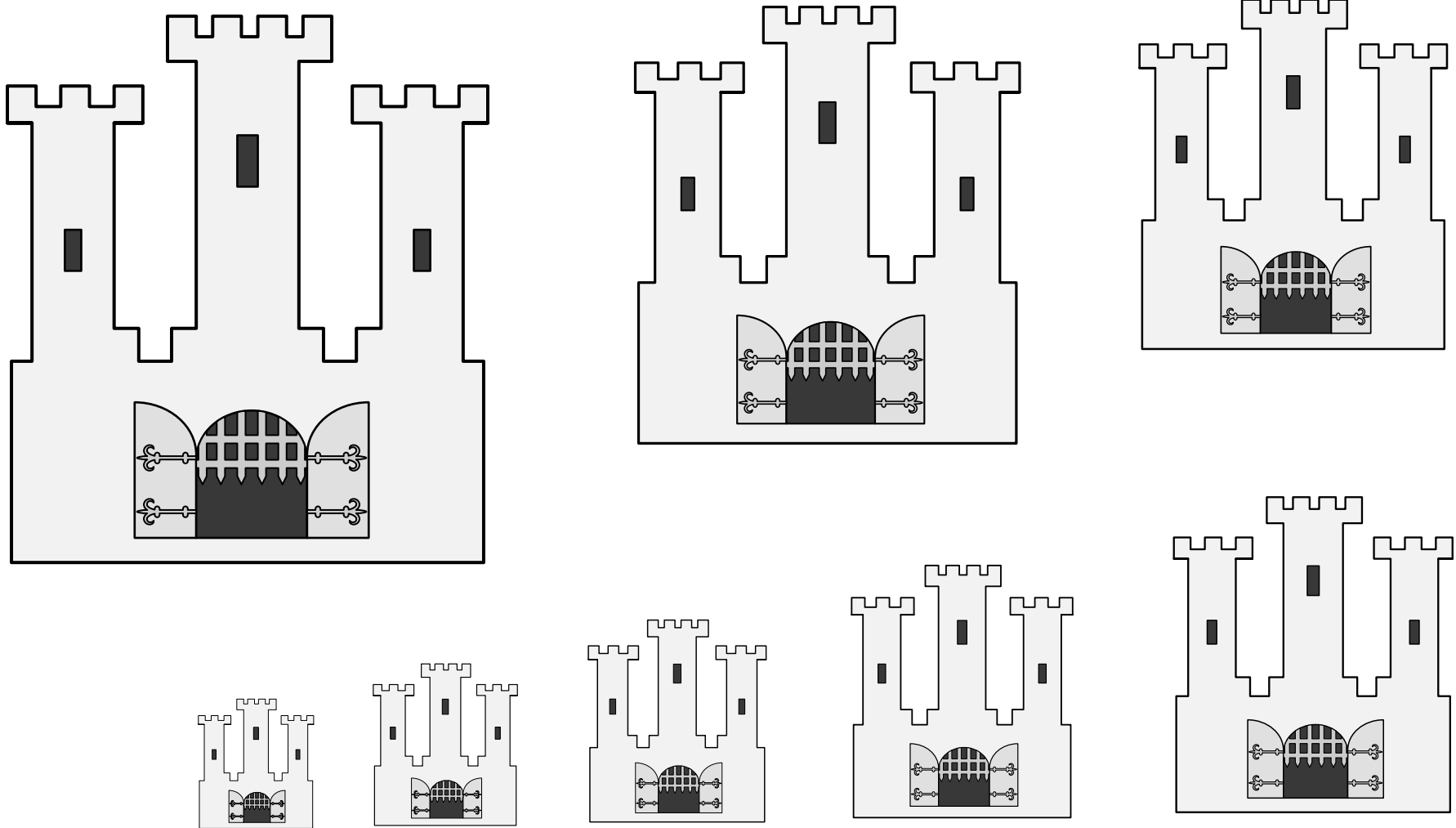

A fortified structure of towers joined by walls.

Default orientation: upright. Proper coloration: gray or argent stone.

Source: Banderia Prutenorum. (Folio 38v.)

Artist unknown.

Castle of Three Towers (6) 17.77

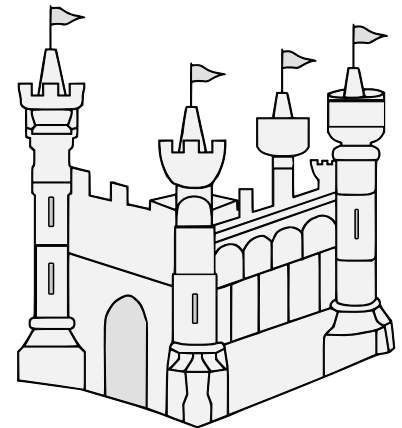
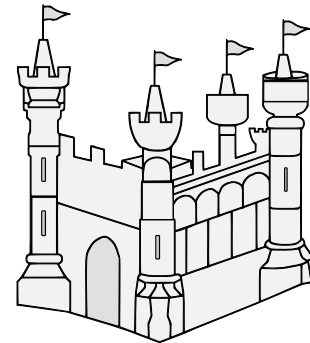
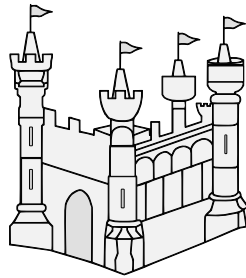
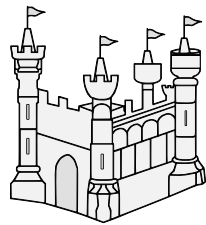
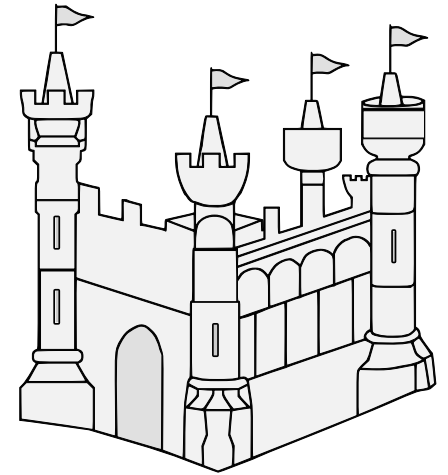
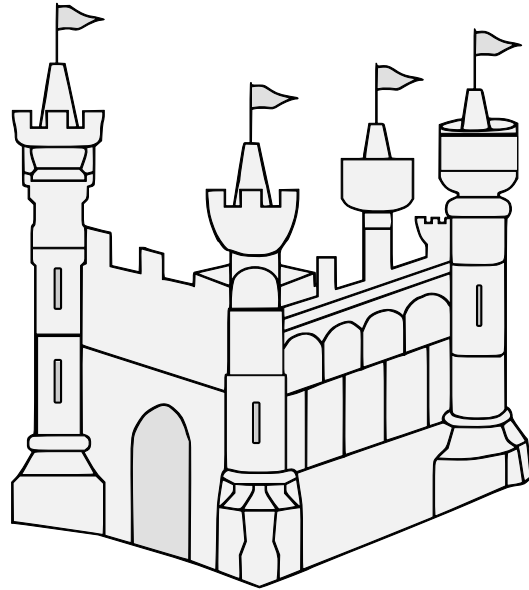
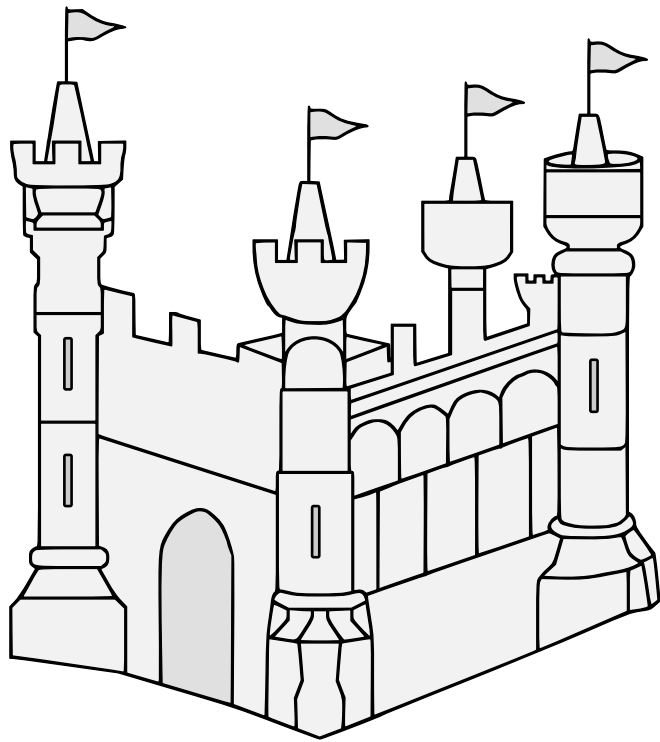

A fortified structure of towers joined by walls.

Default orientation: upright. Proper coloration: gray or argent stone.

Source: Insignia Anglica. Artist unknown.

Adapted by Forveleth Dundee.

Castle of Four Towers 17.78

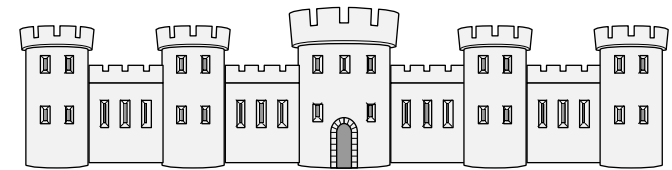
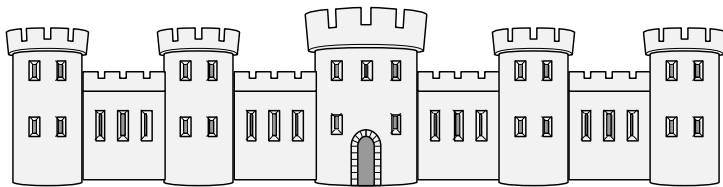
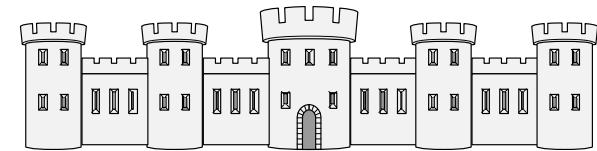
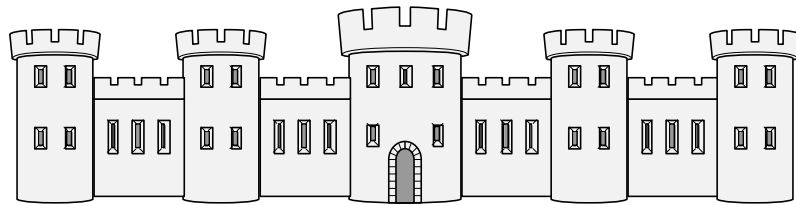
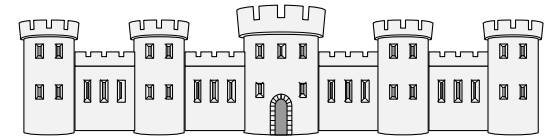
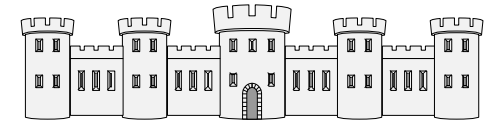
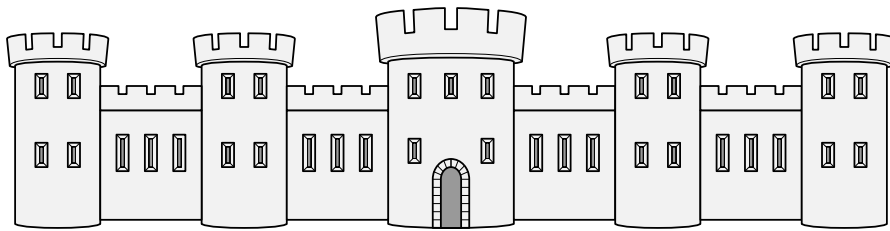

A fortified structure of towers joined by walls.

Default orientation: upright. Proper coloration: gray or argent stone.

Source: *Opus Insignium Armorumque*.

Artist: Johann Weikhard von Valvasor.

Adapted by Mathghamhain Ua Ruadháin.

Castle of Five Towers 17.79

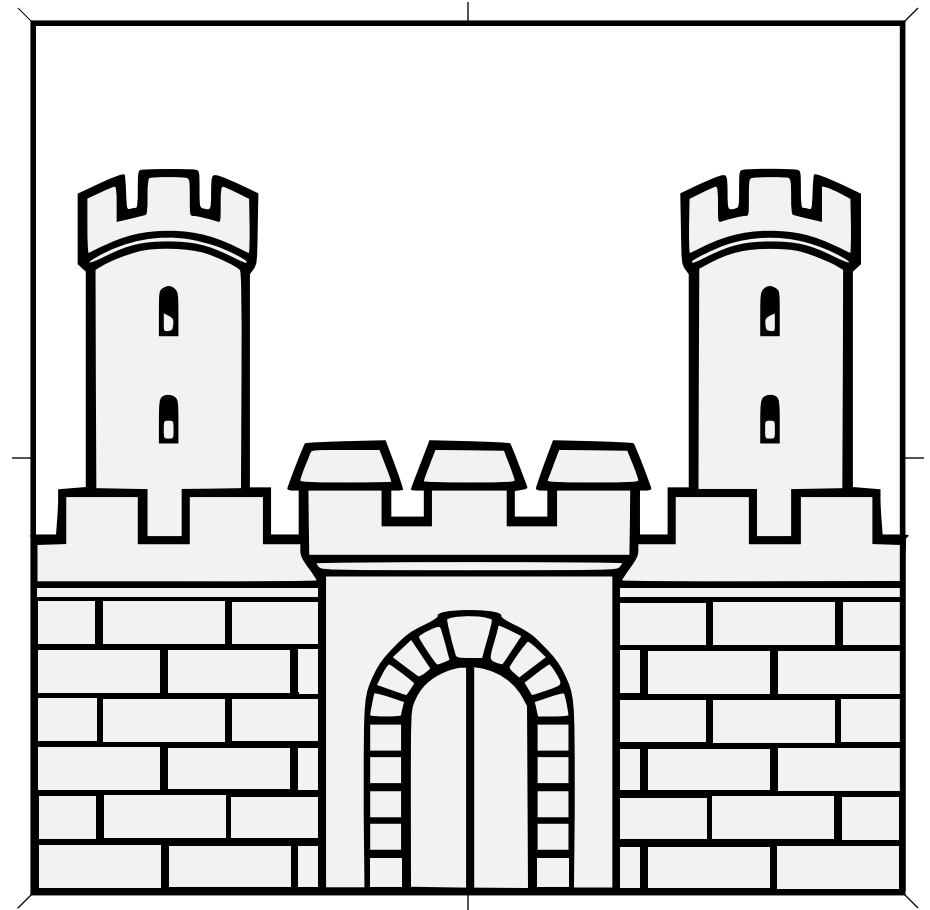
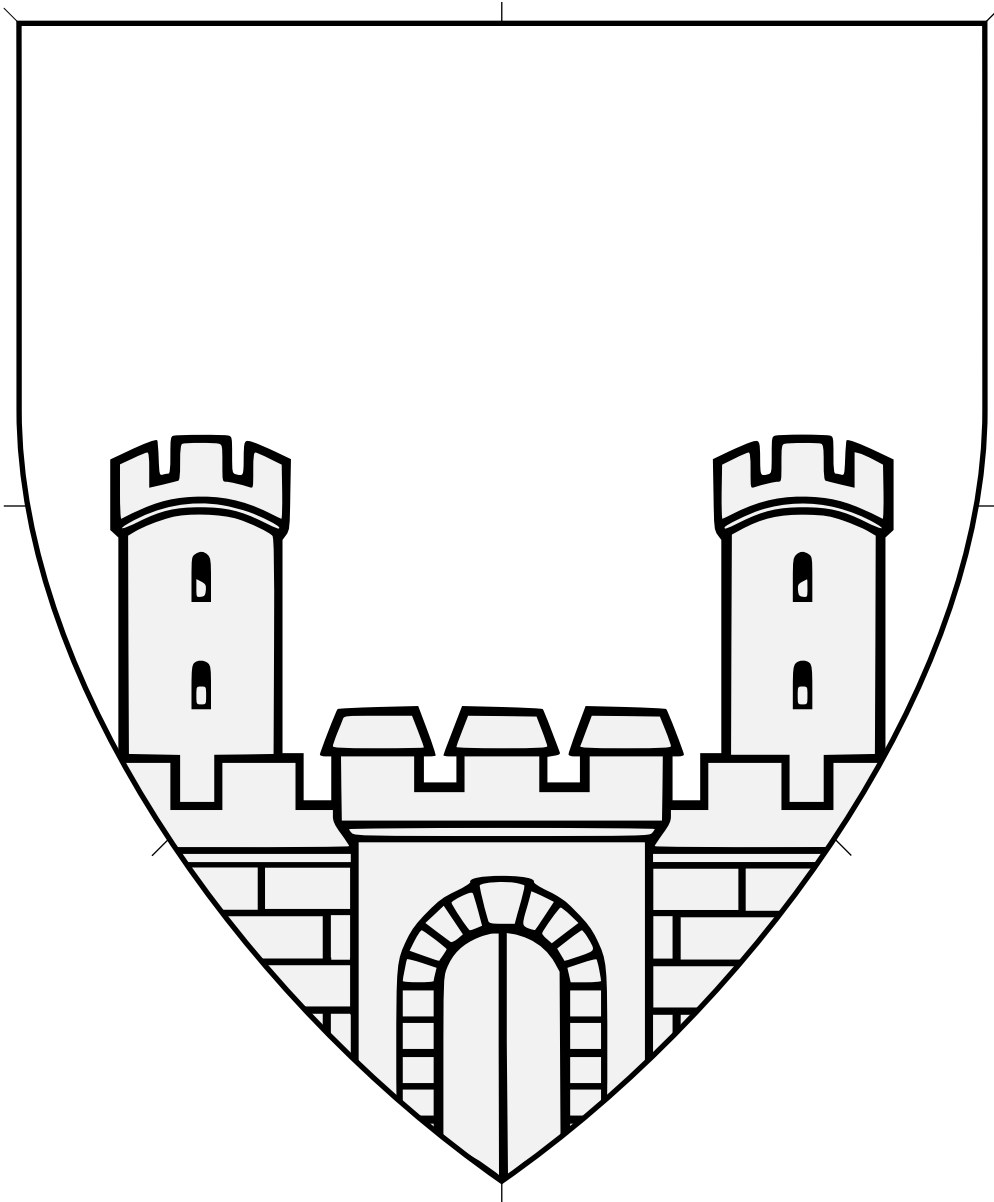

A fortified structure of towers joined by walls.

Default orientation: upright. Proper coloration: gray or argent stone.

Source: Wappen und Siegel des Kreises Alfeld.

Artist: Gustav Völker.

Castle Issuant From Base (1) 17.80

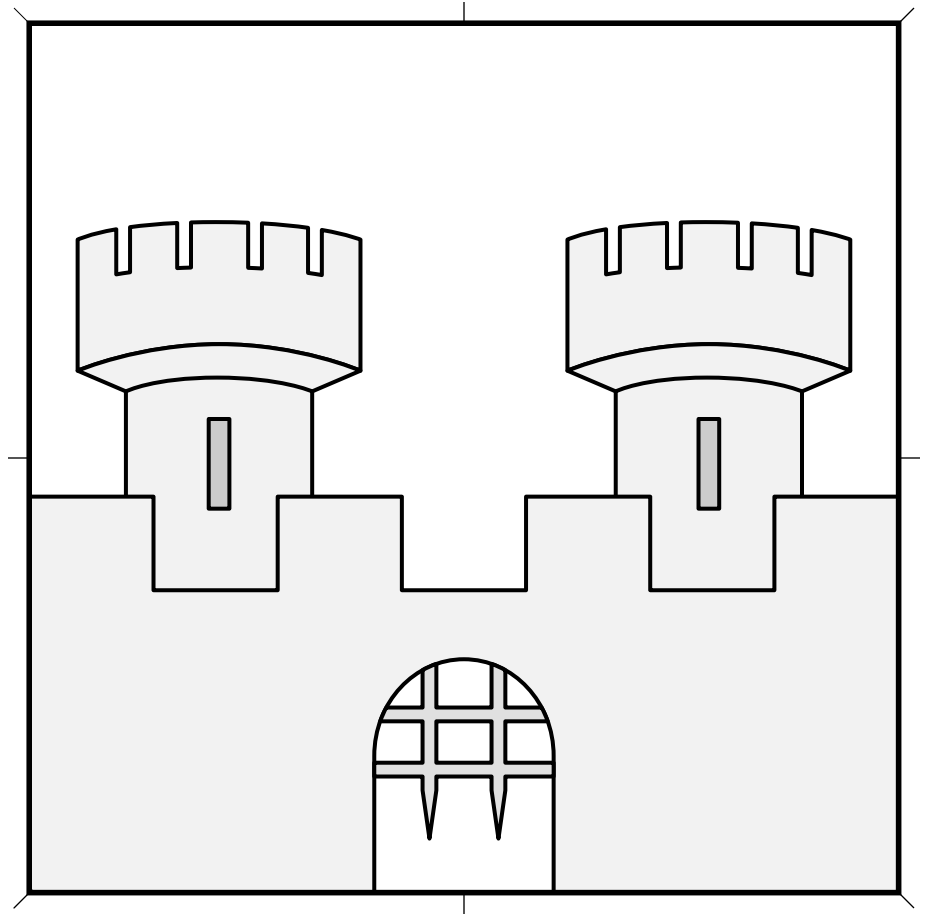
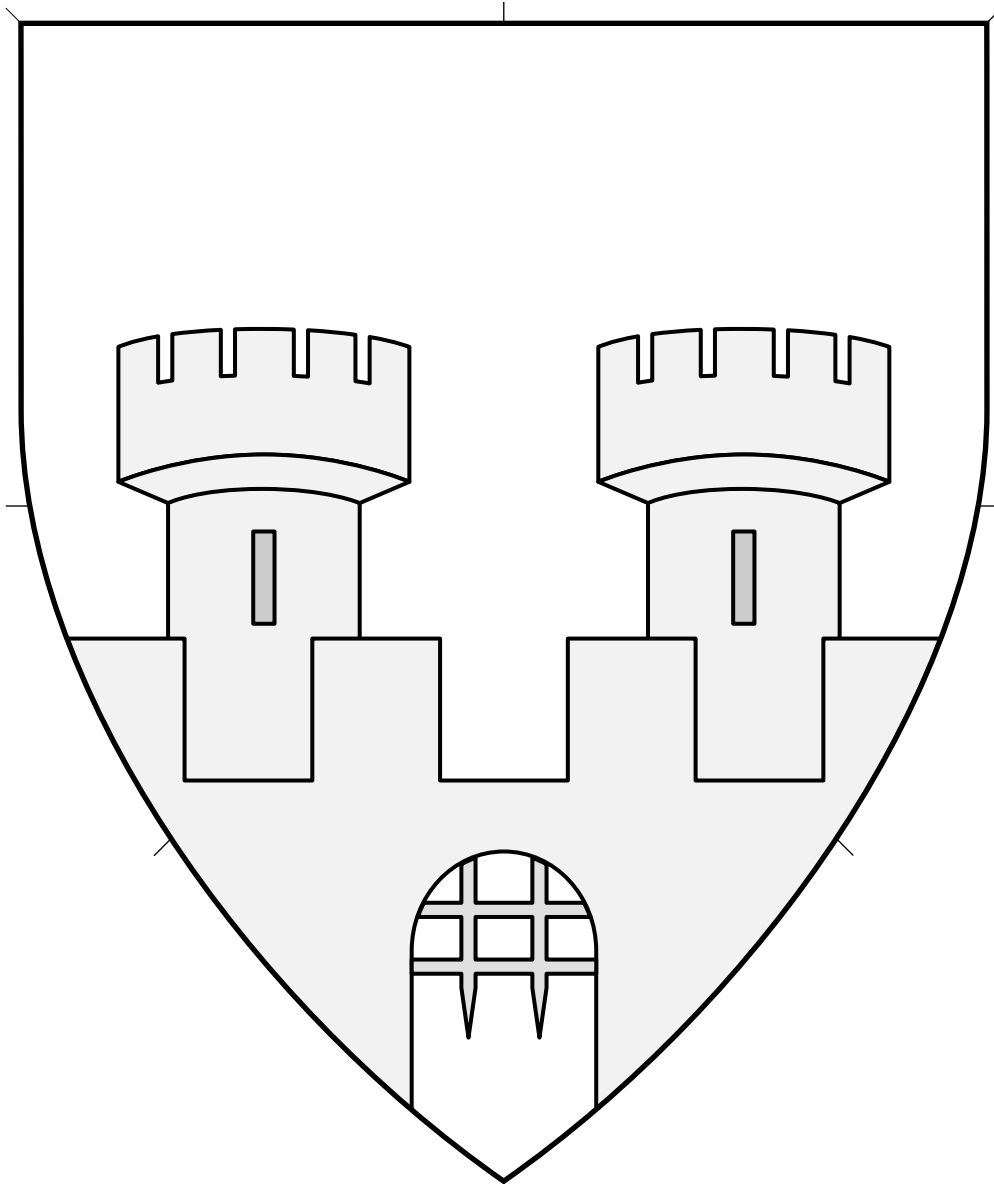

A fortified structure of towers joined by walls.

Default orientation: upright. Proper coloration: gray or argent stone.

Source: Le Grand Armorial Équestre de la Toison d'Or.
Artist unknown. Adapted by Mathghamhain Ua Ruadháin.
(Page 51.)

Castle Issuant From Base (2) 17.81

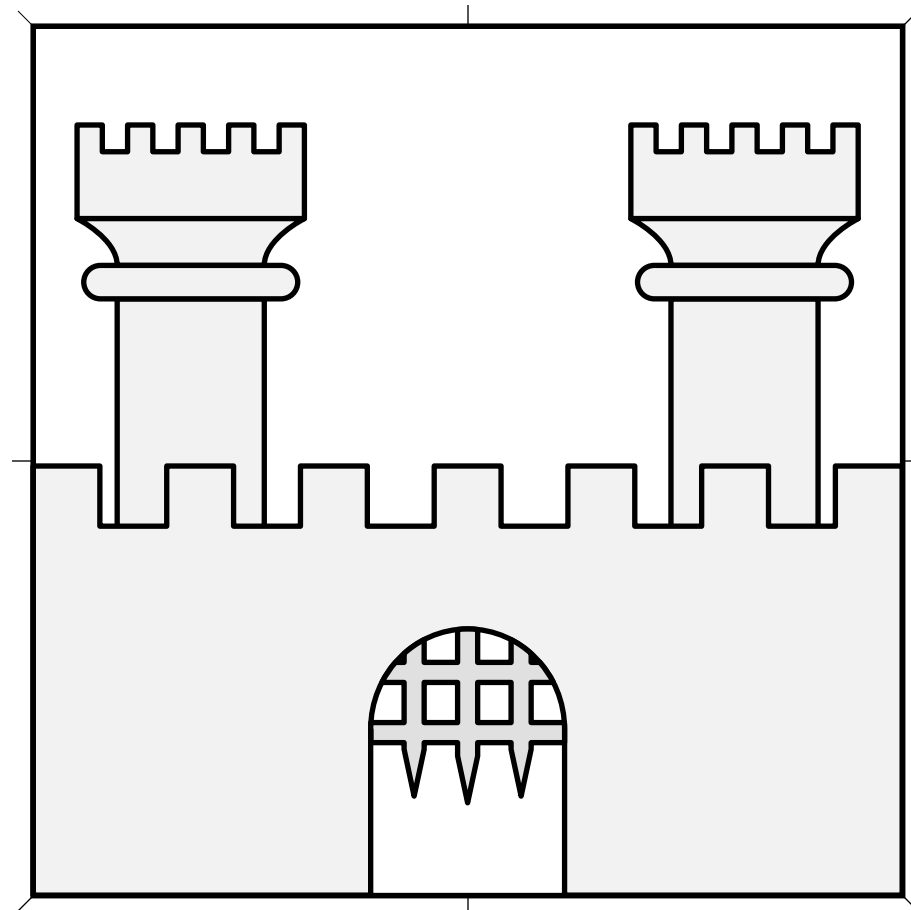
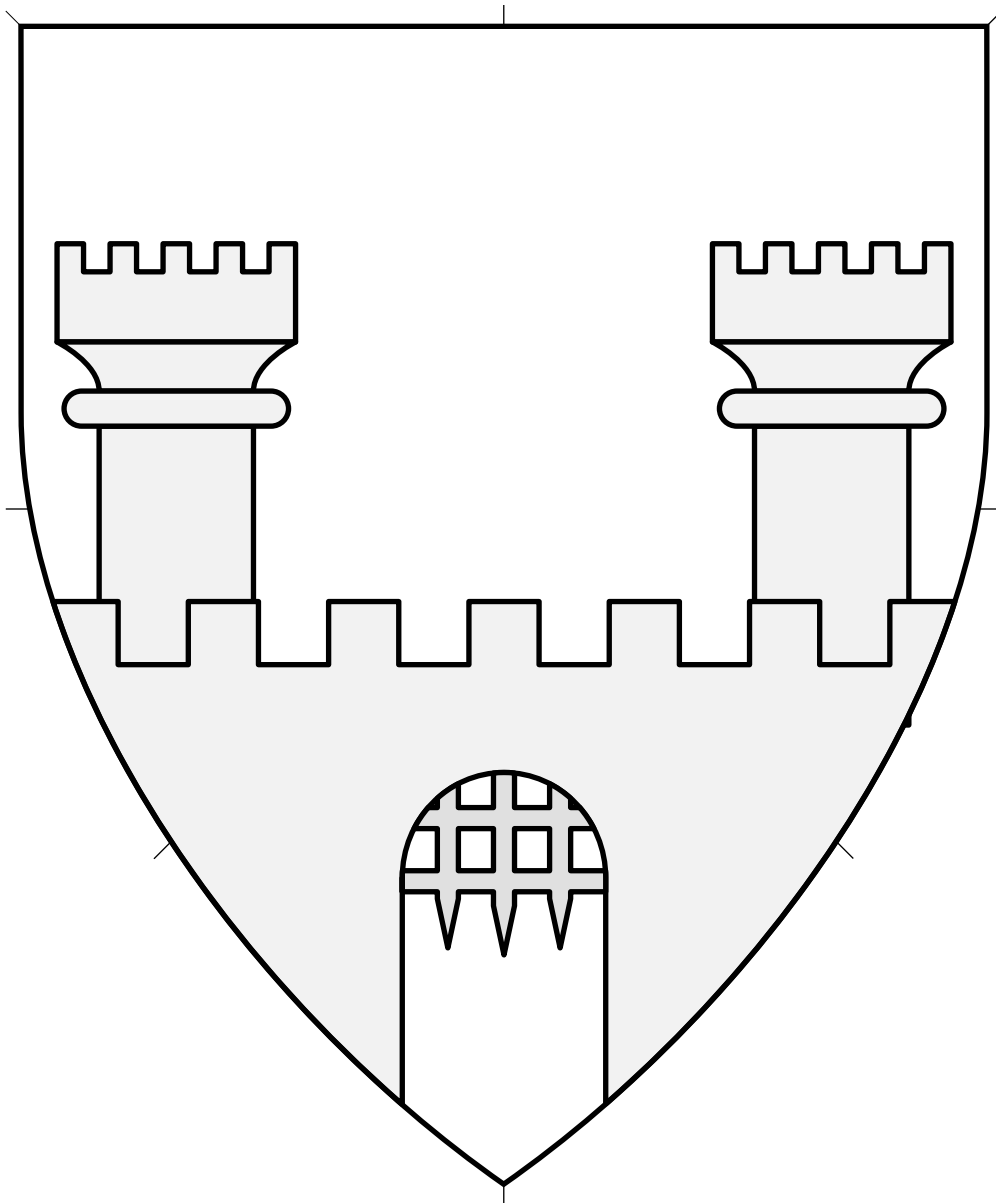

A fortified structure of towers joined by walls.

Default orientation: upright. Proper coloration: gray or argent stone.

Source: Österreichisches Wappenbuch.

Artist unknown.

Castle Issuant From Base (3) 17.82

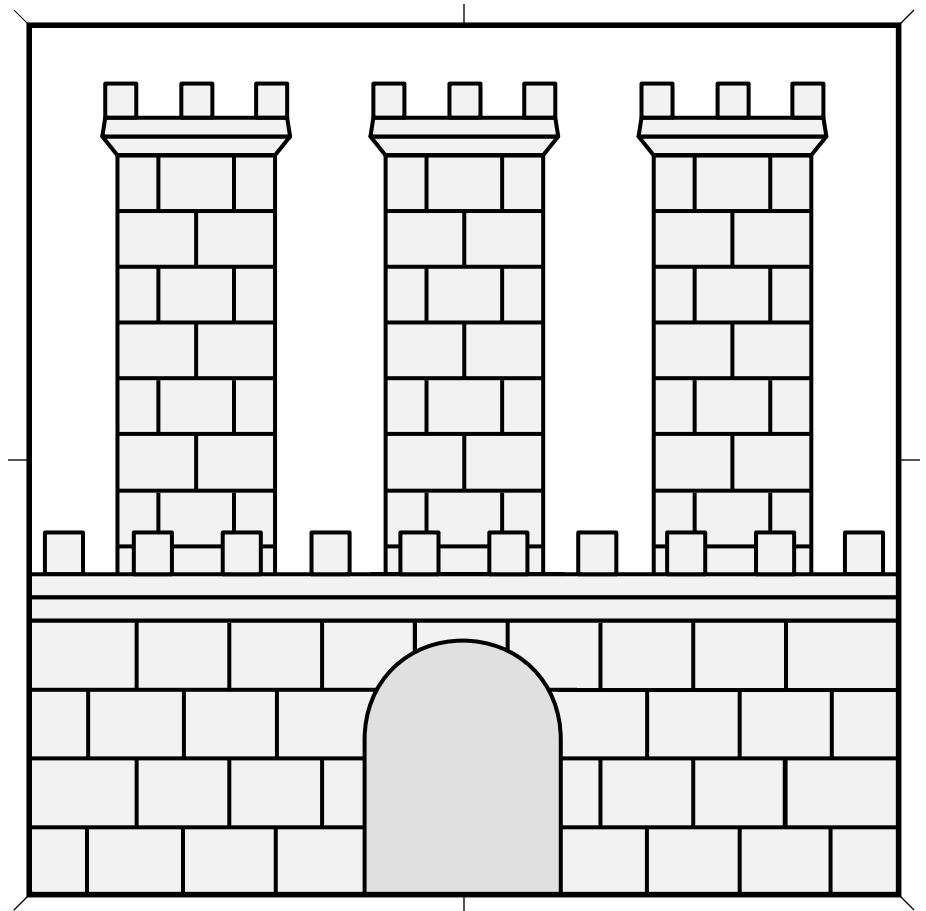
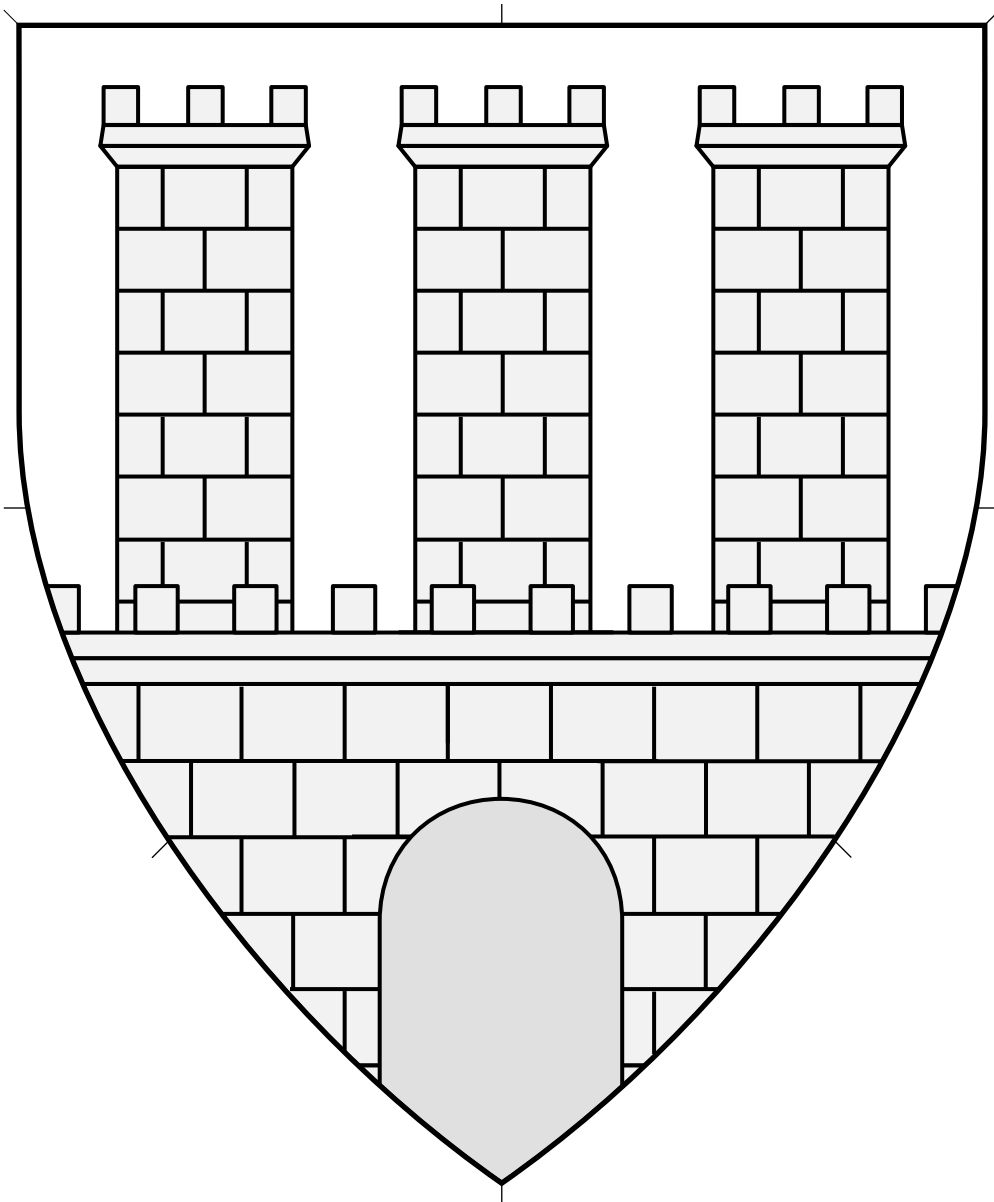

A fortified structure of towers joined by walls.

Default orientation: upright. Proper coloration: gray or argent stone.

Source: WappenWiki.
Artist: Joakim Spuller.

Castle of Three Towers Issuant From Base 17.83

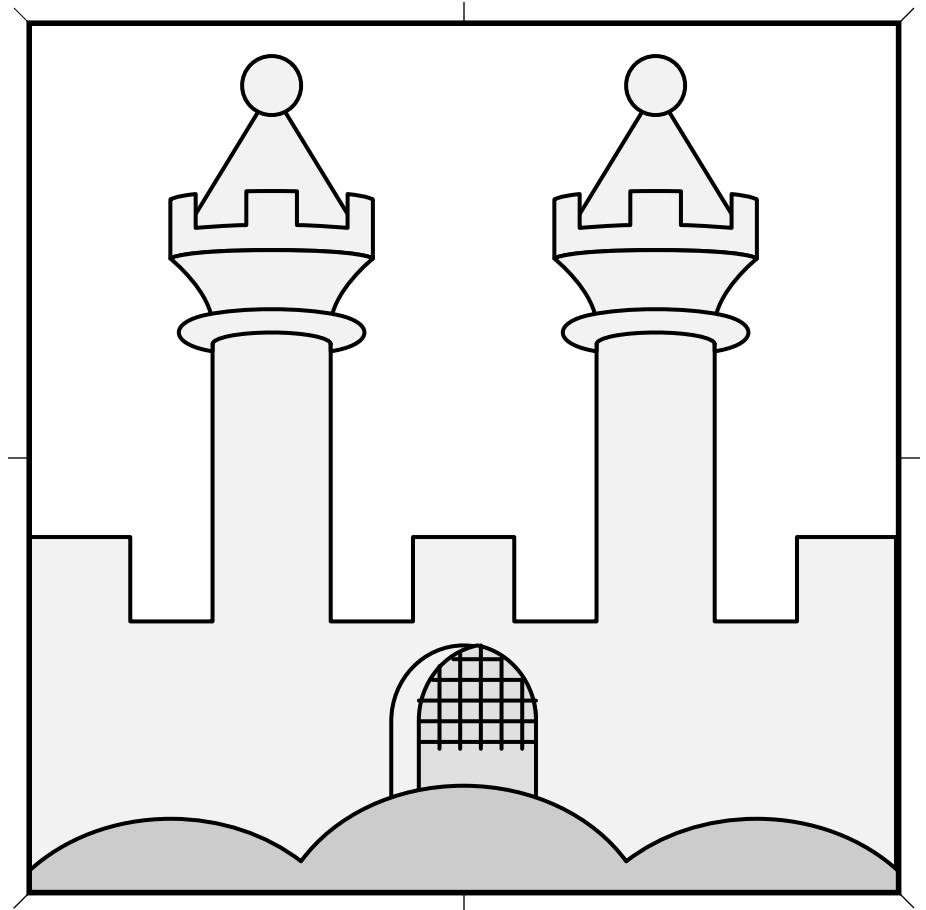
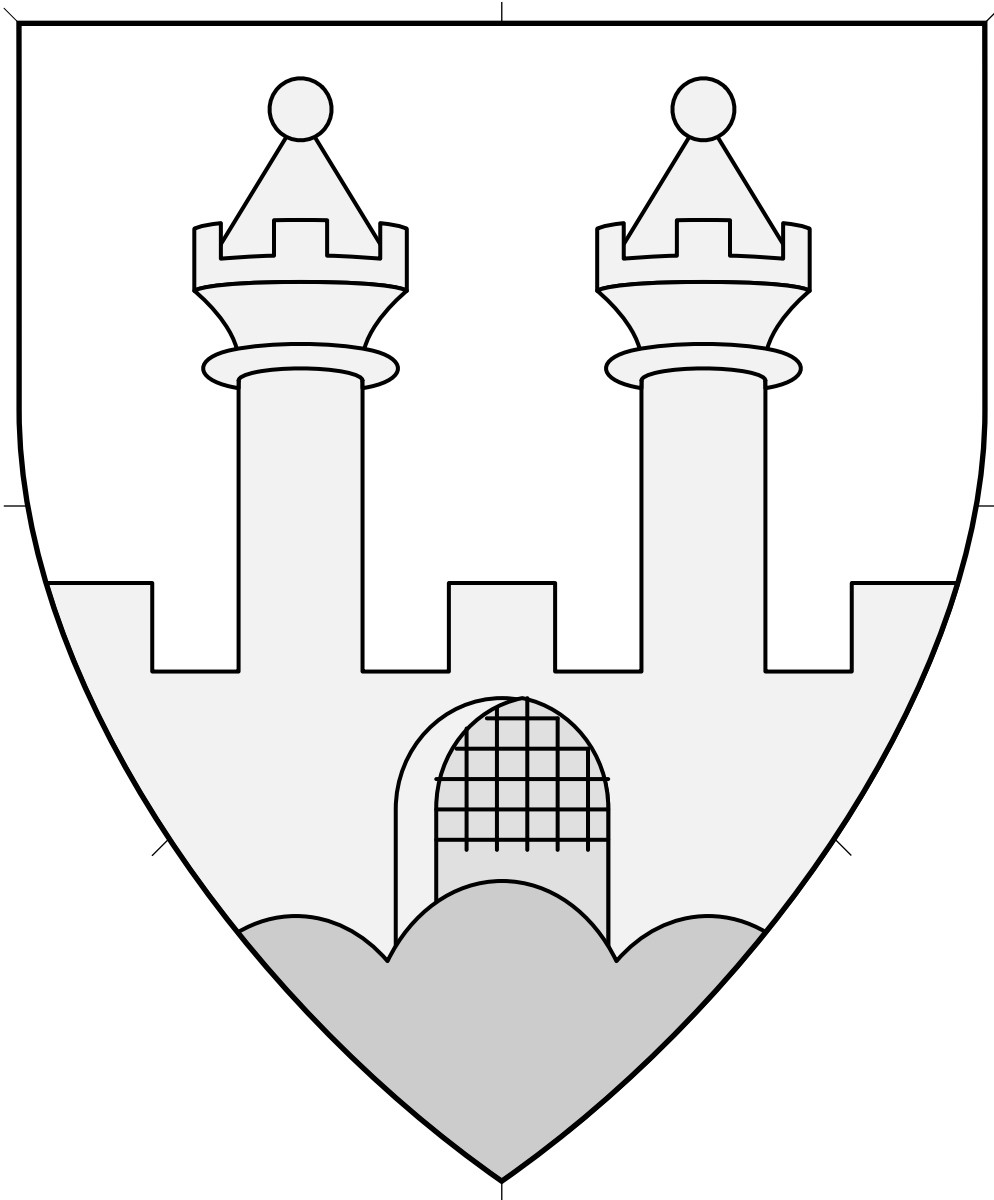

A fortified structure of towers joined by walls.

Default orientation: upright. Proper coloration: gray or argent stone.

Source: Wernigerode Armorial.
Artist unknown. (Page 511.)

Castle Issuant from a Trimount 17.84

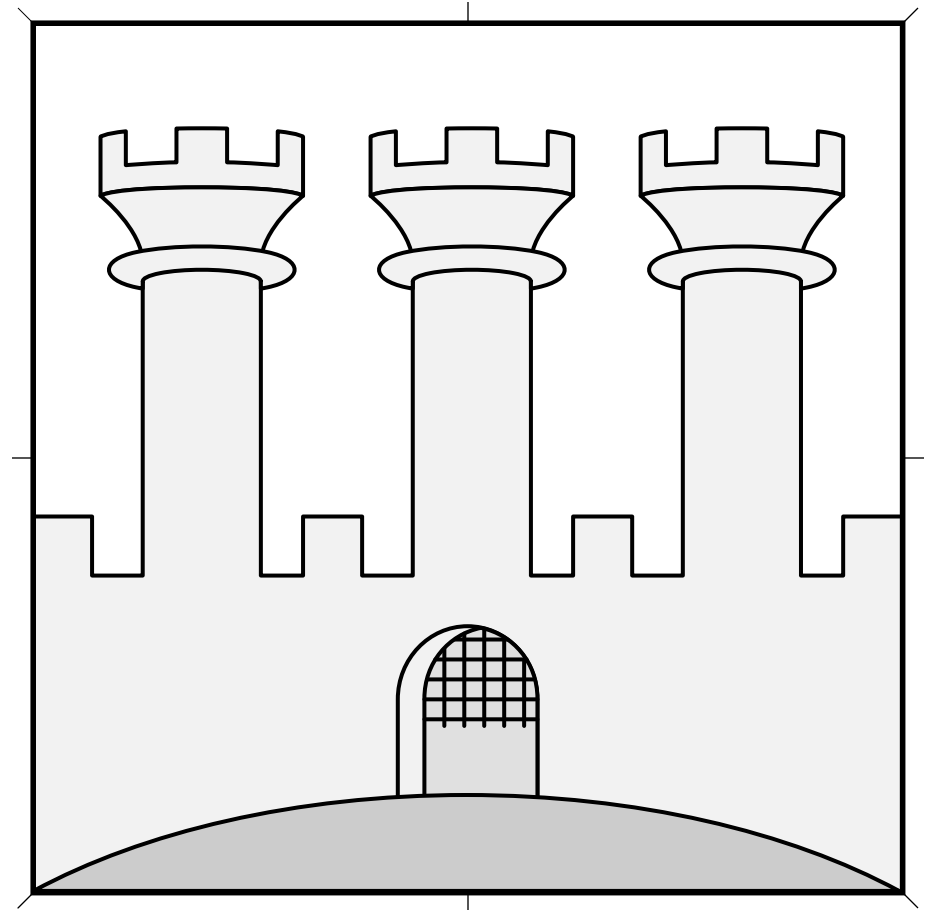
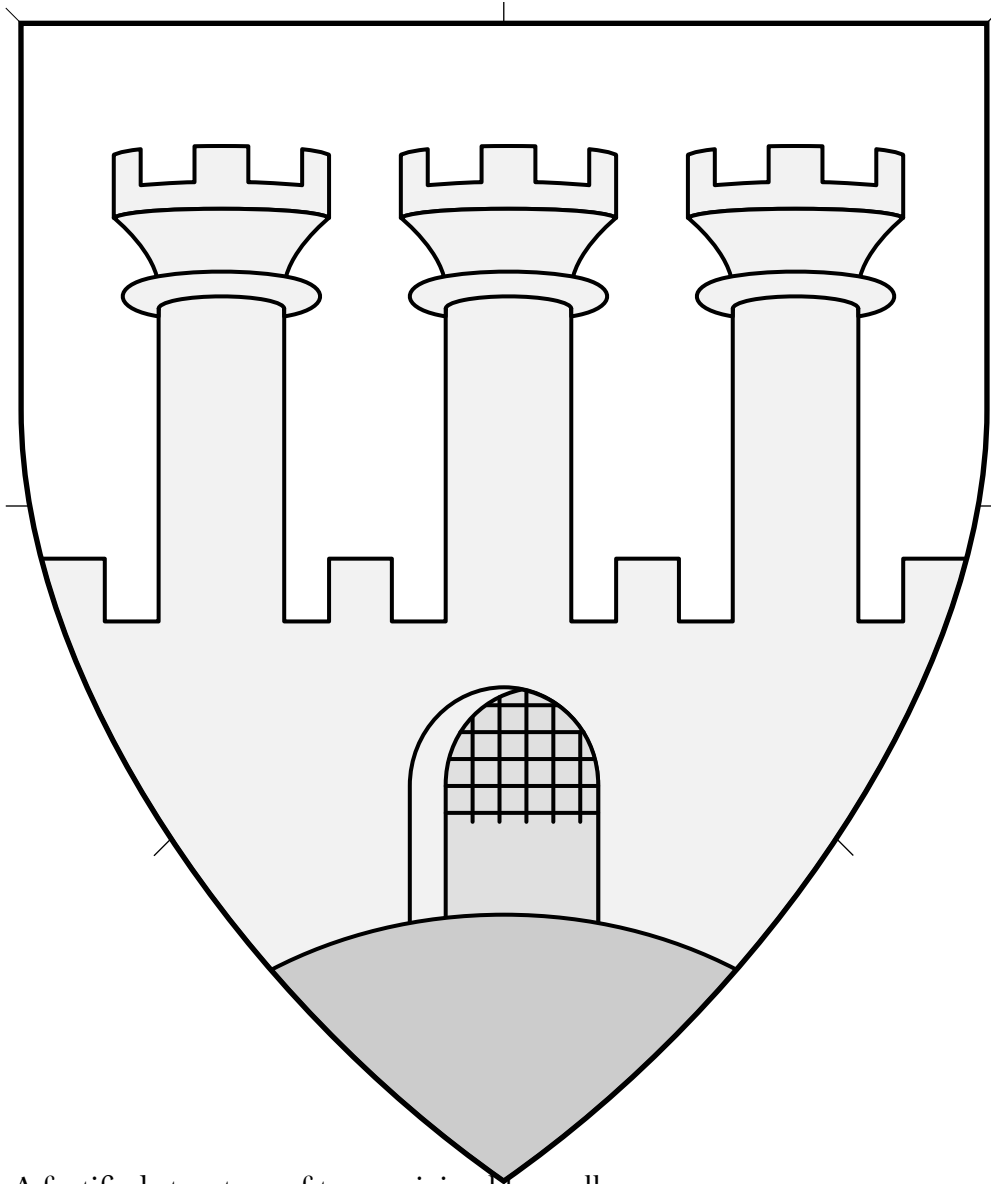

A fortified structure of towers joined by walls.

Default orientation: upright. Proper coloration: gray or argent stone.

Source: Wernigerode Armorial. Artist unknown. (Page 511.)

Castle of Three Towers Issuant from a Mount 17.85

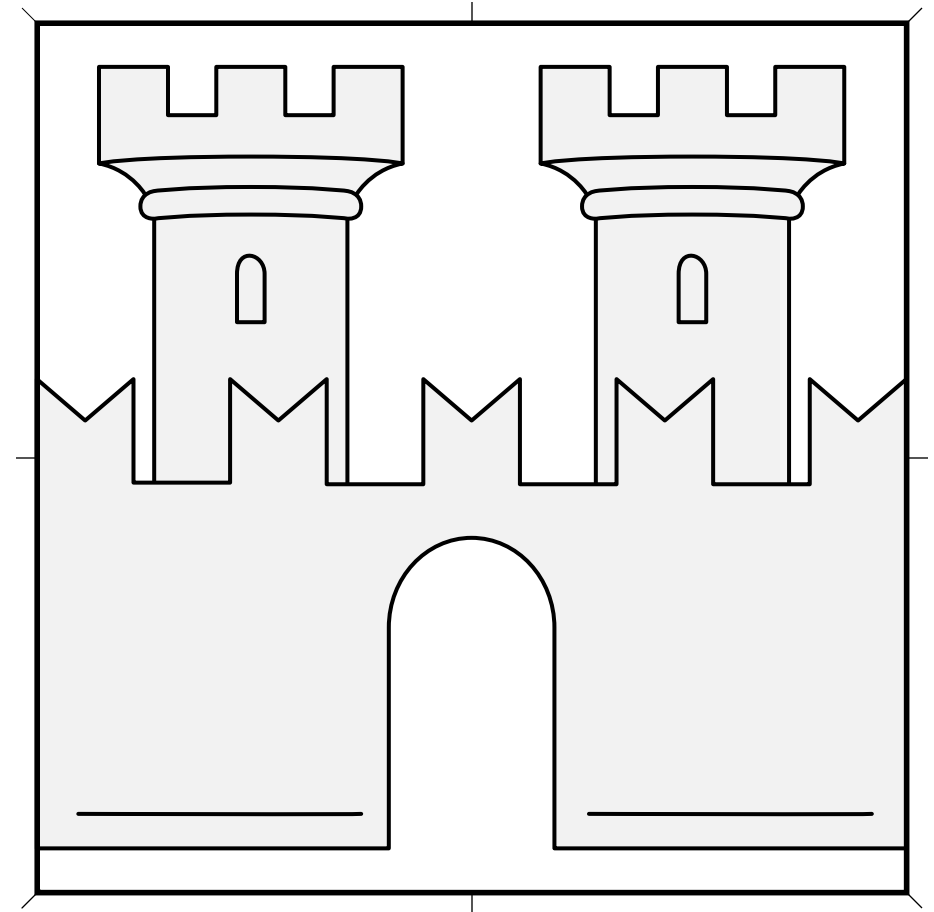
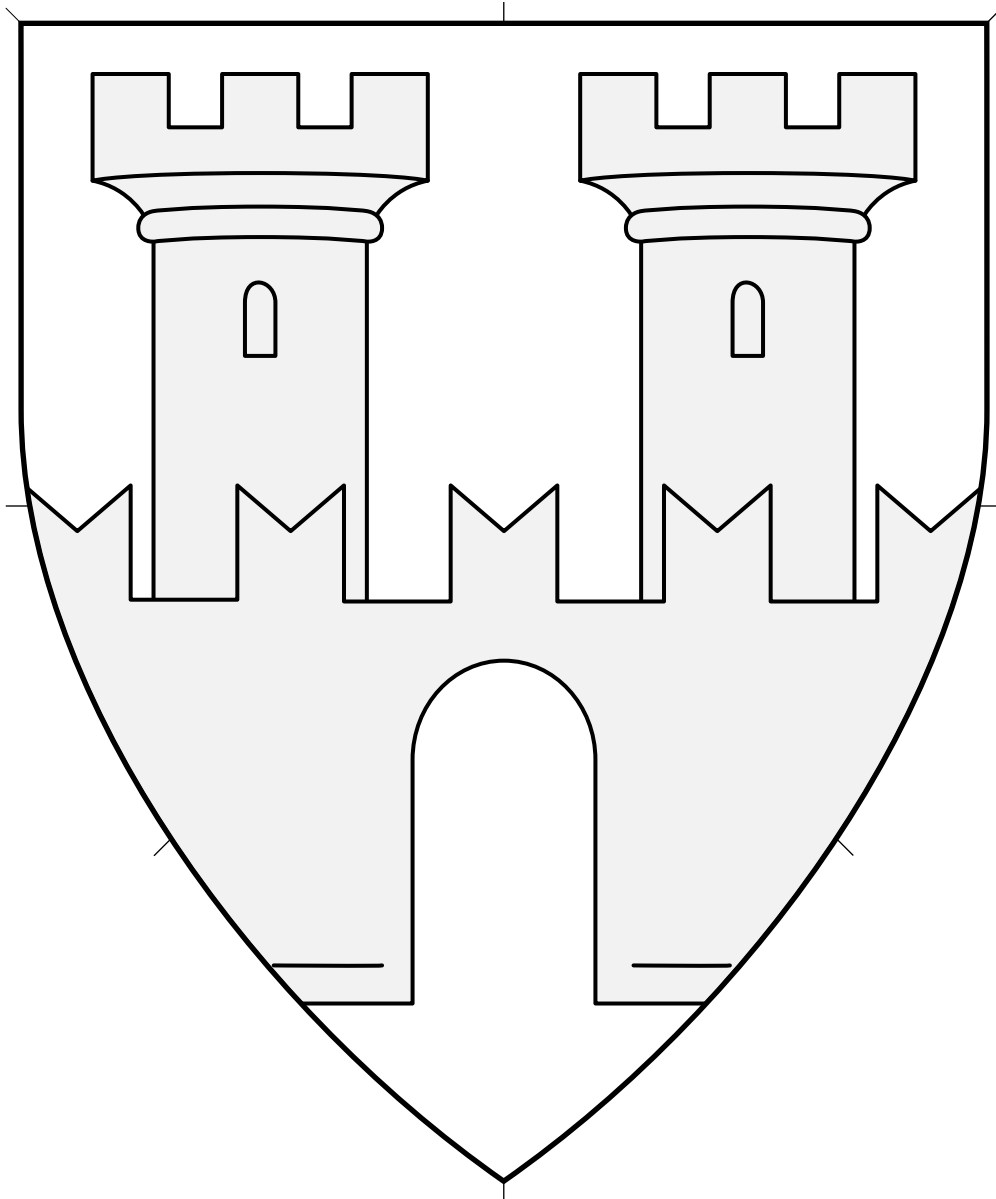

A fortified structure of towers joined by walls.

Default orientation: upright. Proper coloration: gray or argent stone.

Source: Wappenbuch der Arlberg-Bruderschaft.

Artist: Vigil Raber. (Page 128.)

Castle Throughout 17.86

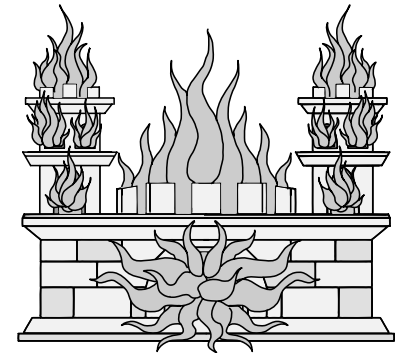
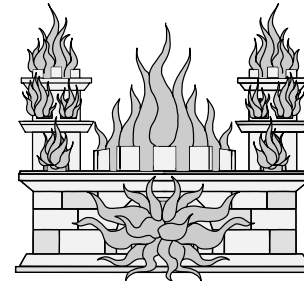
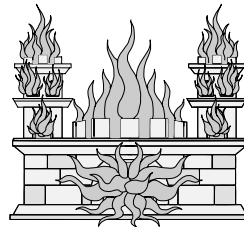
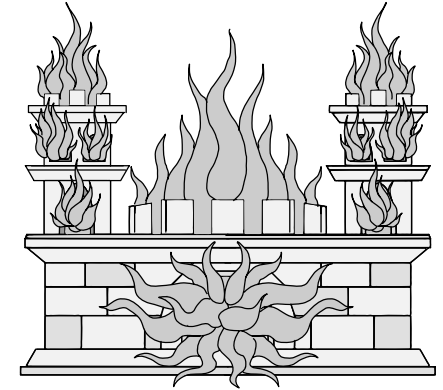
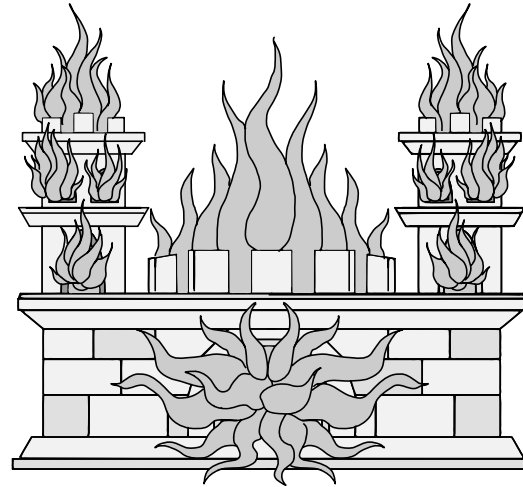
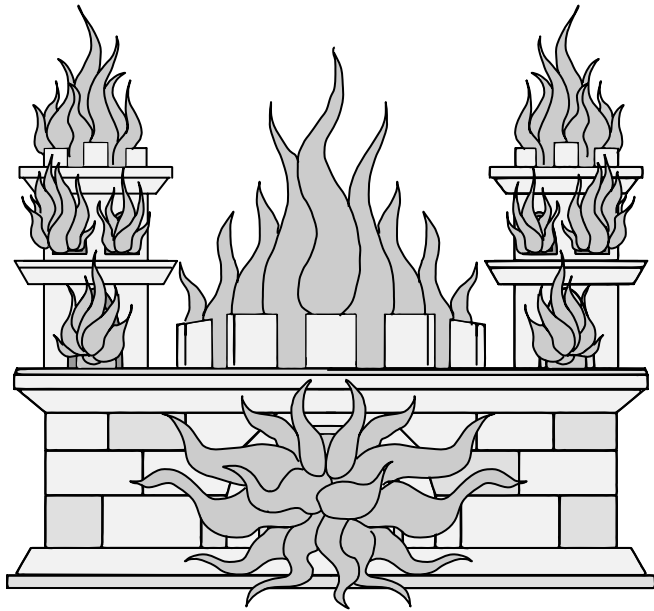

A fortified structure of towers joined by walls.

Default orientation: upright. Proper coloration: gray or argent stone.

Source: Stemmario Trivulziano. Artist: Gian Antonio da Tradate. (Page 131.)

Adapted by Wylet Fraser.

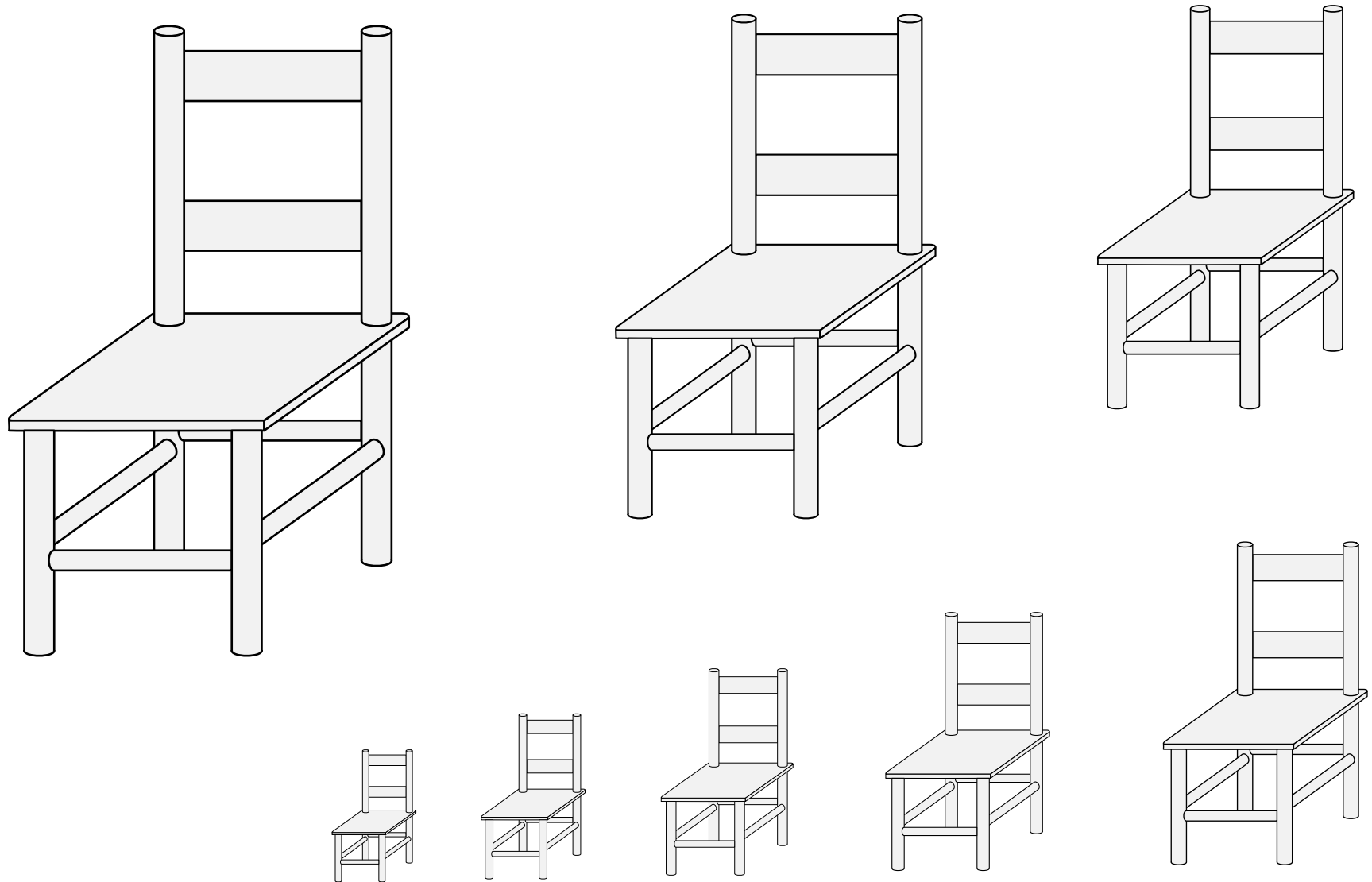

A seat with a back.

Default orientation: upright. Proper coloration: brown wood.

Source: Siebmacher's Wappenbuch of 1605. Artist: Johann Siebmacher.
(Arms of von Doltzky, page 144.)

Chair (1) 17.88

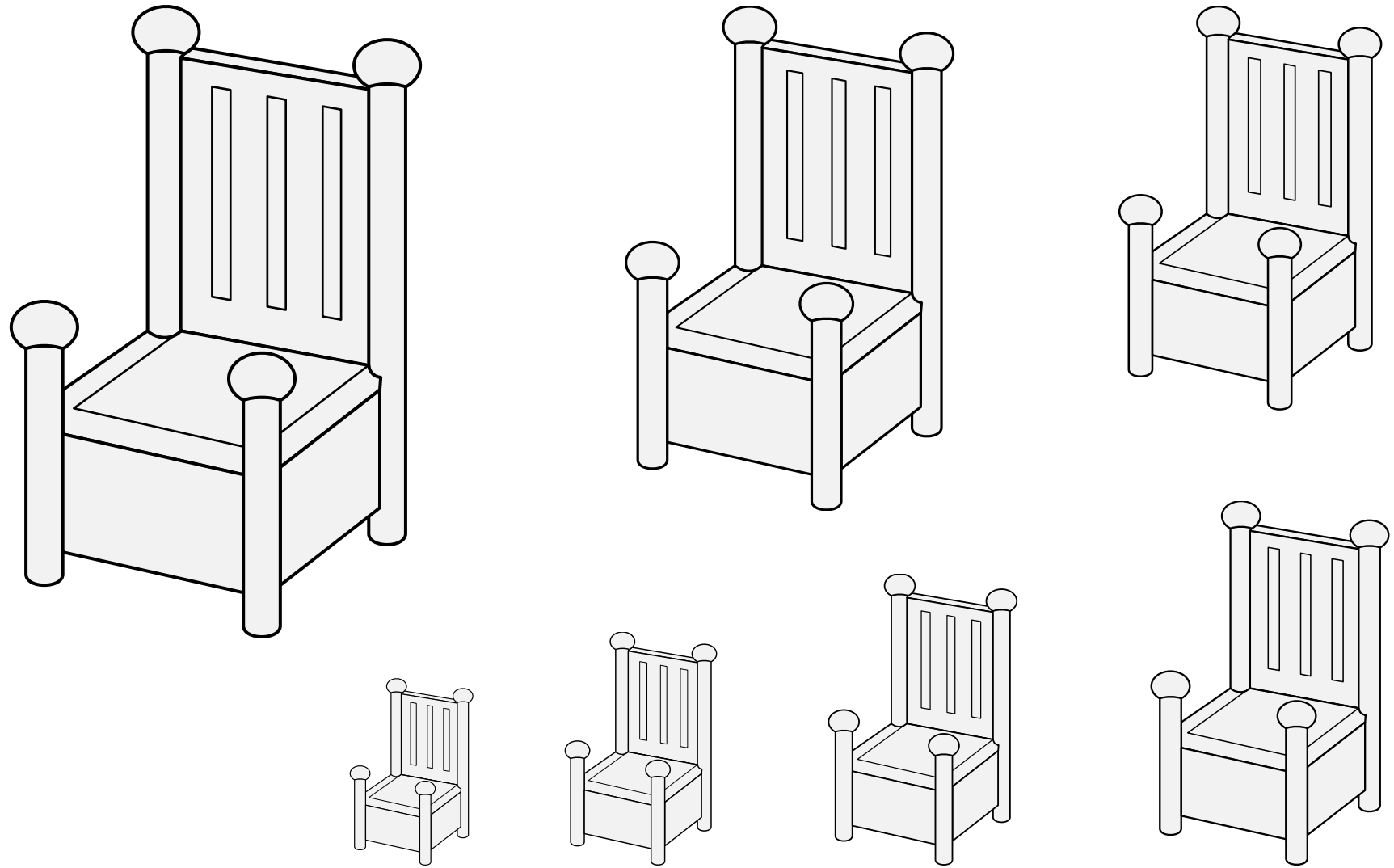

A seat with a back.

Default orientation: upright. Proper coloration: brown wood.

Source: Sammelband Mehrerer Wappenbücher. Artist unknown. (Folio 125r.)

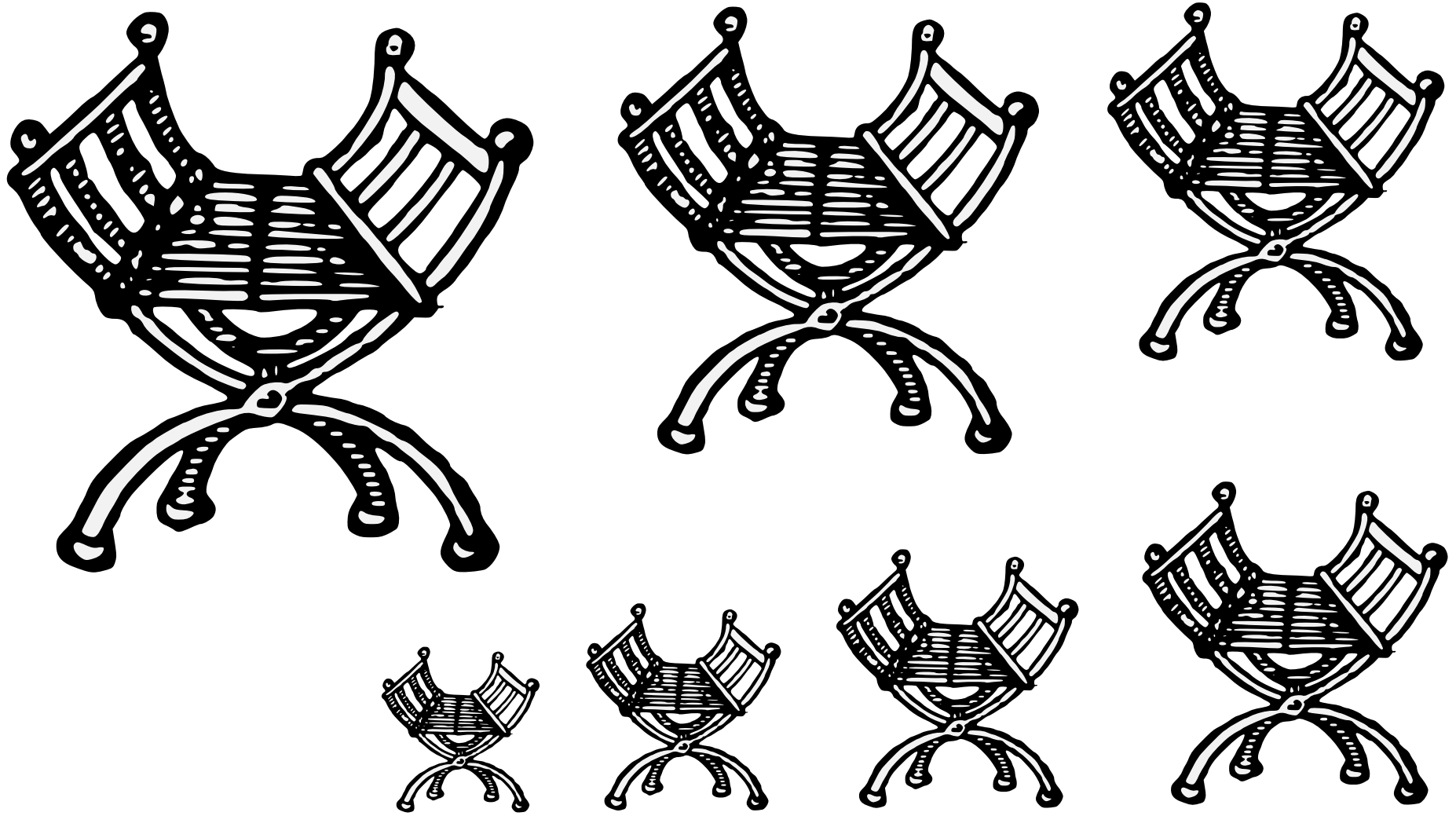

A folding seat. Sometimes blazoned an "antique chair."

Default orientation: upright. No proper coloration.

Source: Le Blason Des Armoiries. Artist: Jérôme de Bara. (Page 157.)

Chair, Curule 17.90

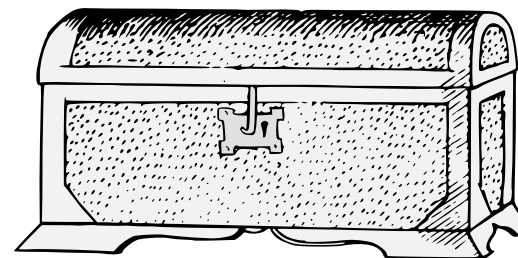
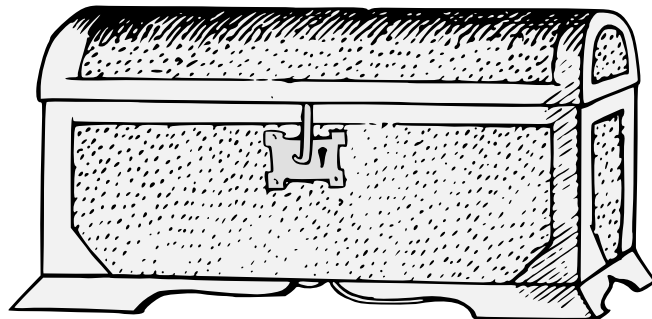
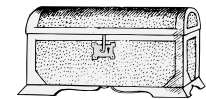
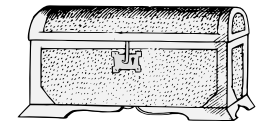
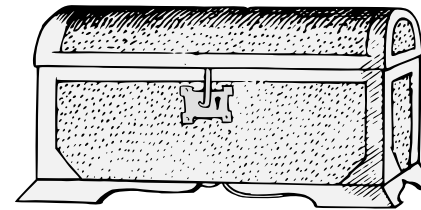
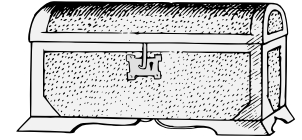
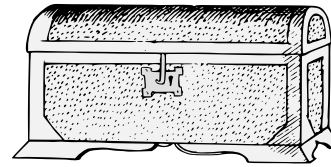
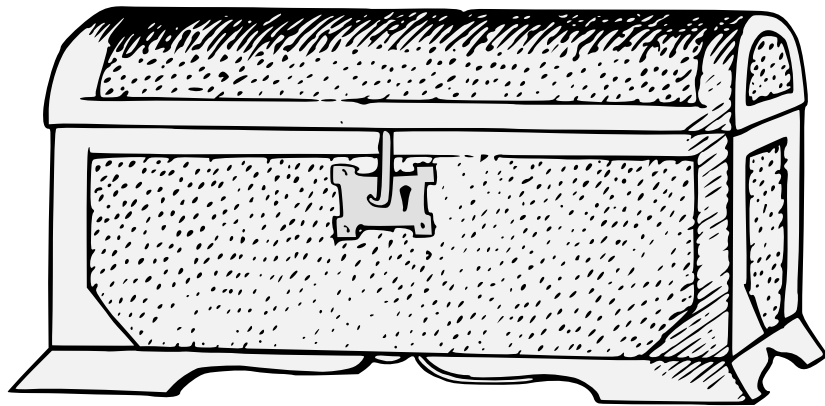

A storage box with a hinged lid.

Default orientation: fesswise. Proper coloration: brown wood.

Source: Opera Dell'arte Del Cucinare. Artist unknown. (Page 967.)

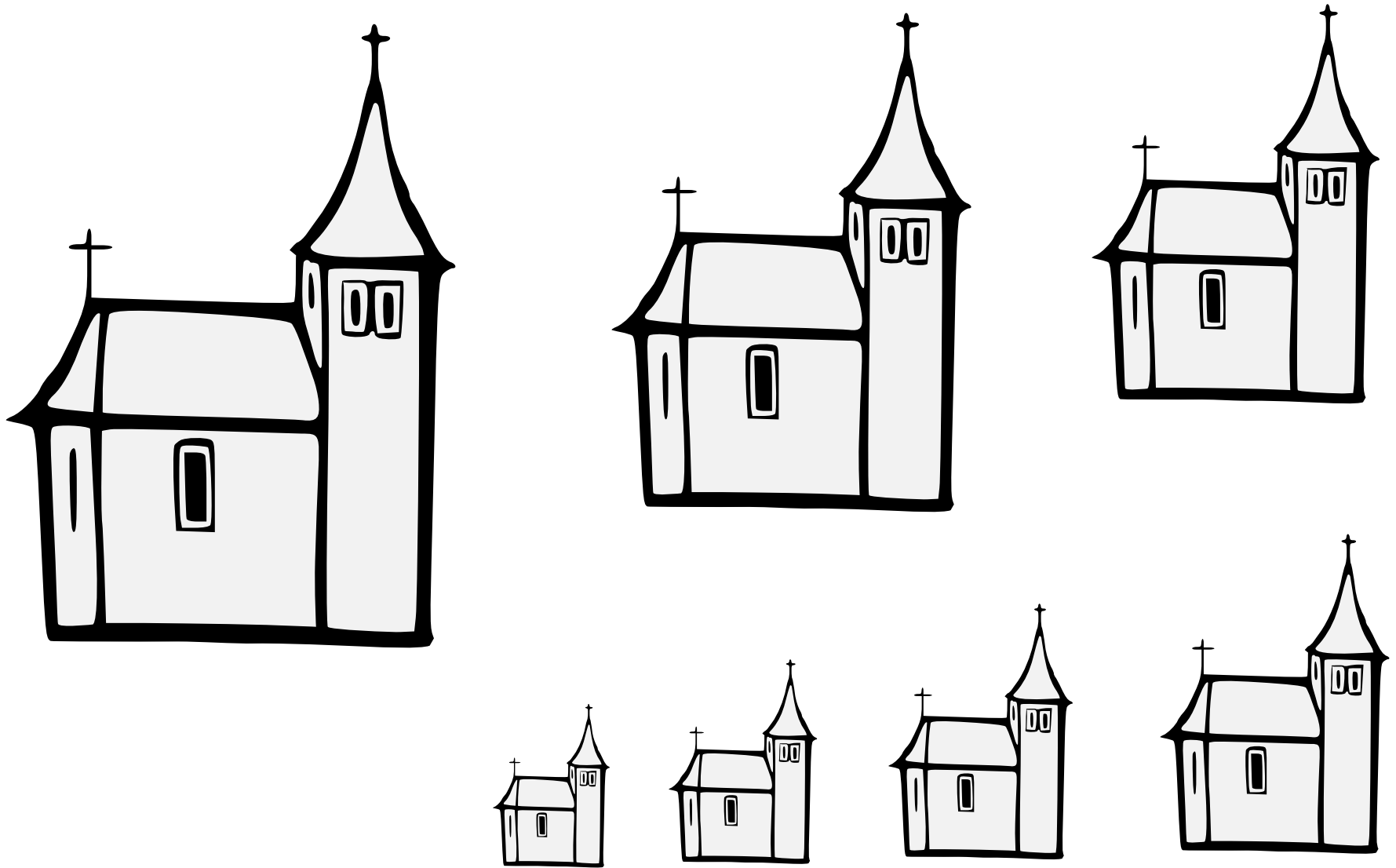

A religious edifice.

Default orientation: upright. No proper coloration.

Source: Opus Insignium Armorumque. Artist: Johann Weikhard von Valvasor.
(From the civic arms of Kring, page 23.)

Church (1) 17.92

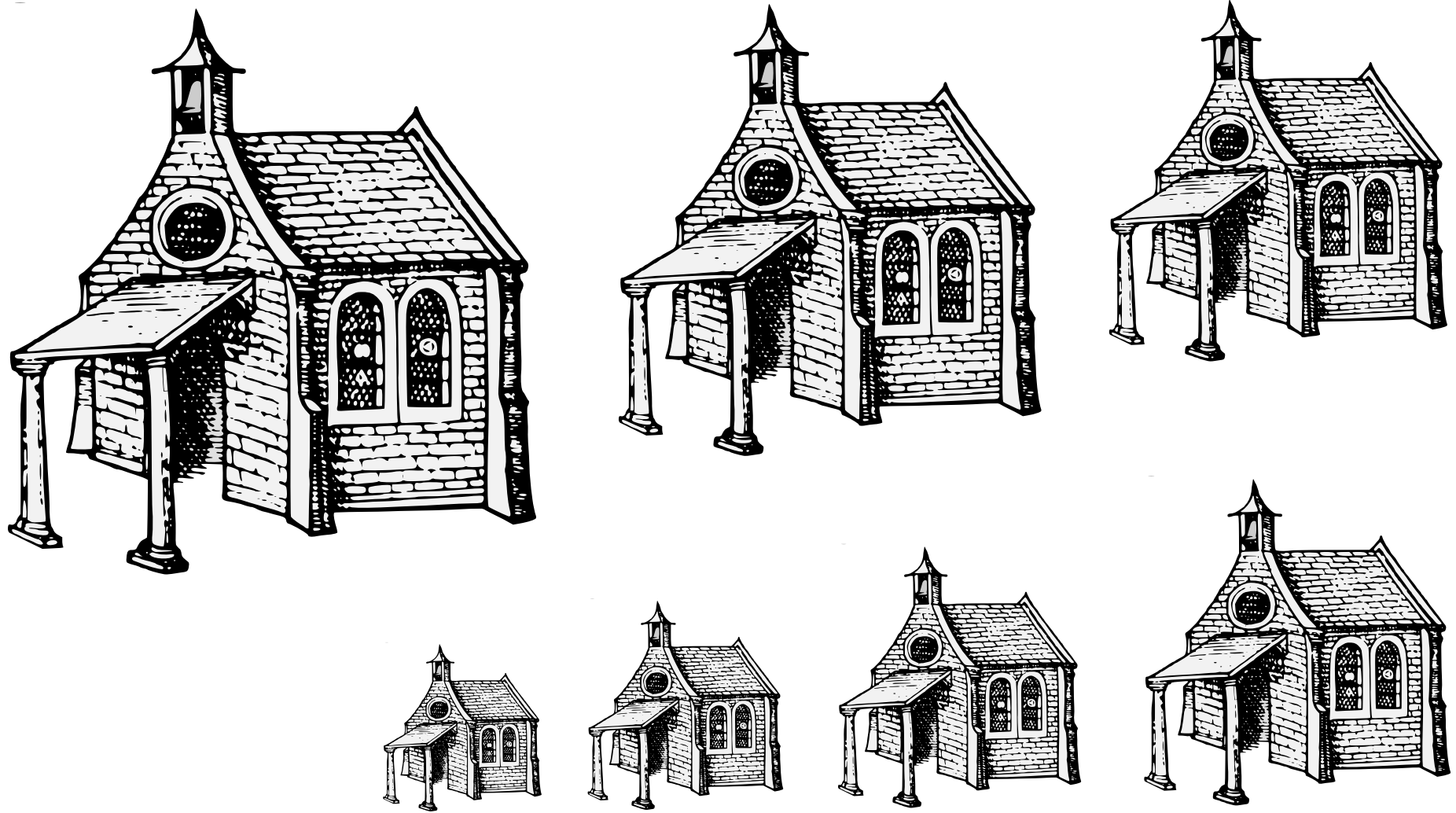

A religious edifice.

Default orientation: upright. No proper coloration.

Source: Le Blason Des Armoiries. Artist: Jérôme de Bara. (Page 188.)

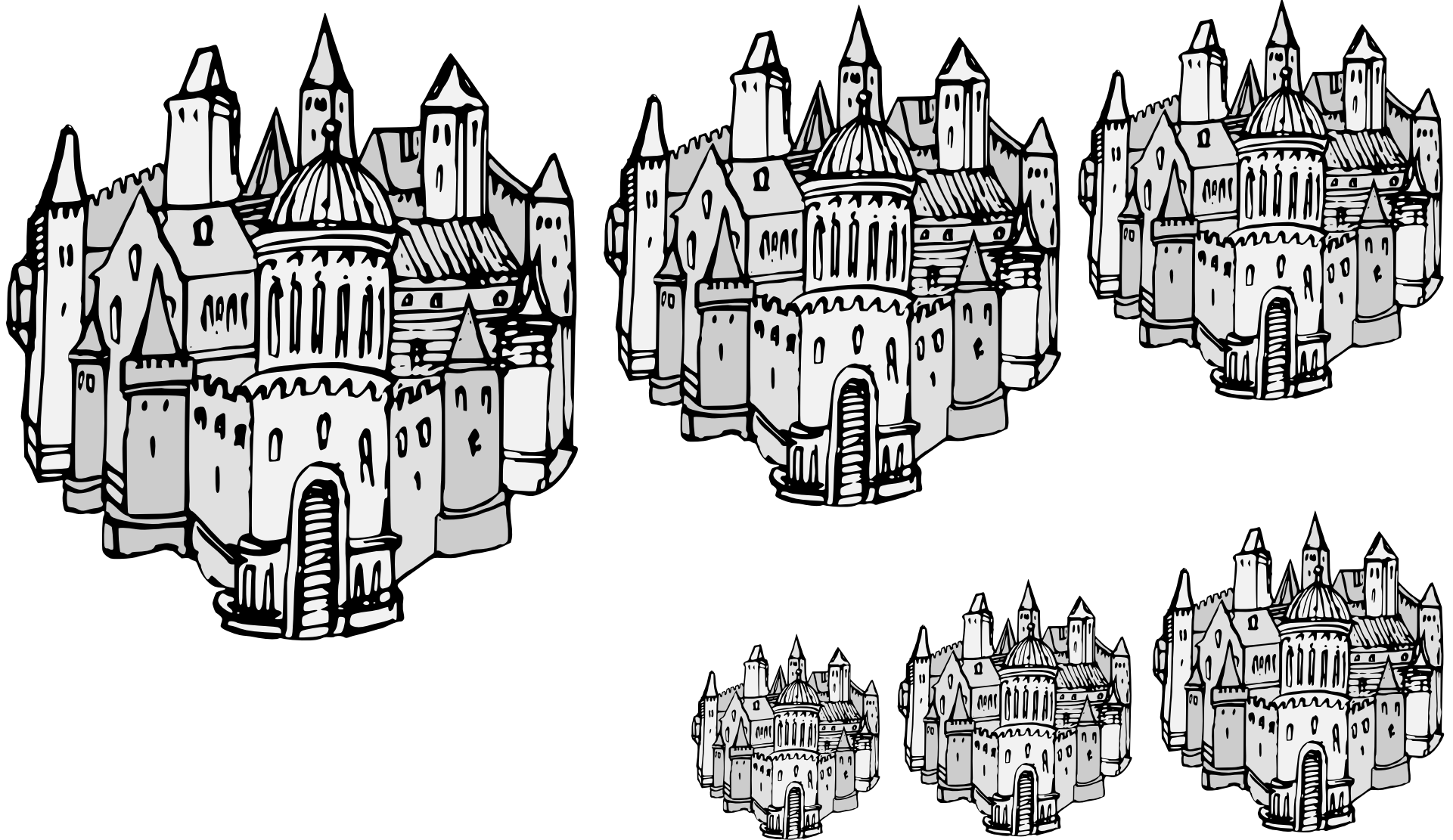

A group of non-military buildings enclosed by a wall.

Default orientation: upright. No proper coloration.

Source: Wappenbuch der Arlberg-Bruderschaft.

Artist: Vigil Raber. (Folio 2r.)

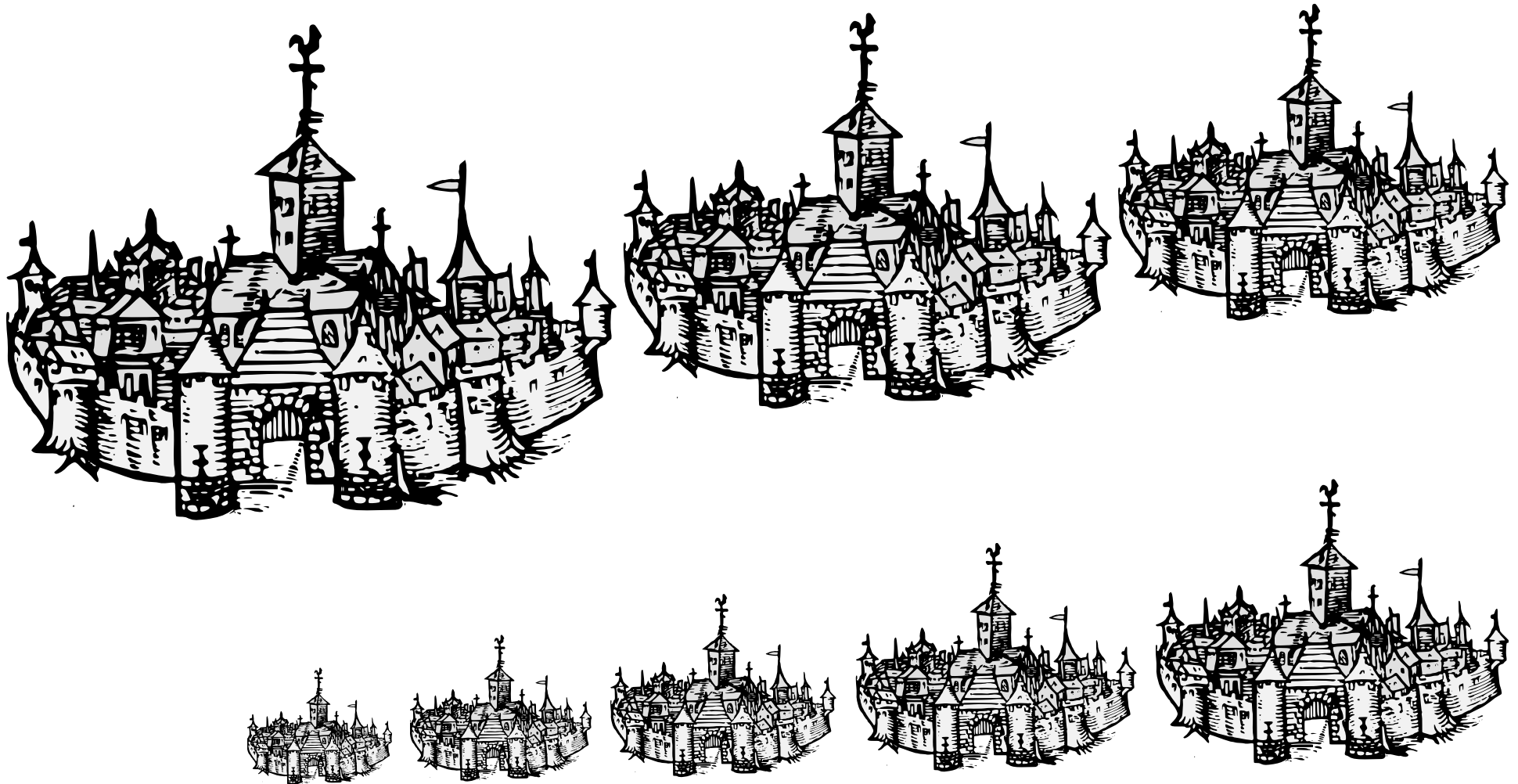

A group of non-military buildings enclosed by a wall.

Default orientation: upright. No proper coloration.

Source: Le Blason Des Armoiries.

Artist: Jérôme de Bara. (Page 58.)

City (2) 17.95

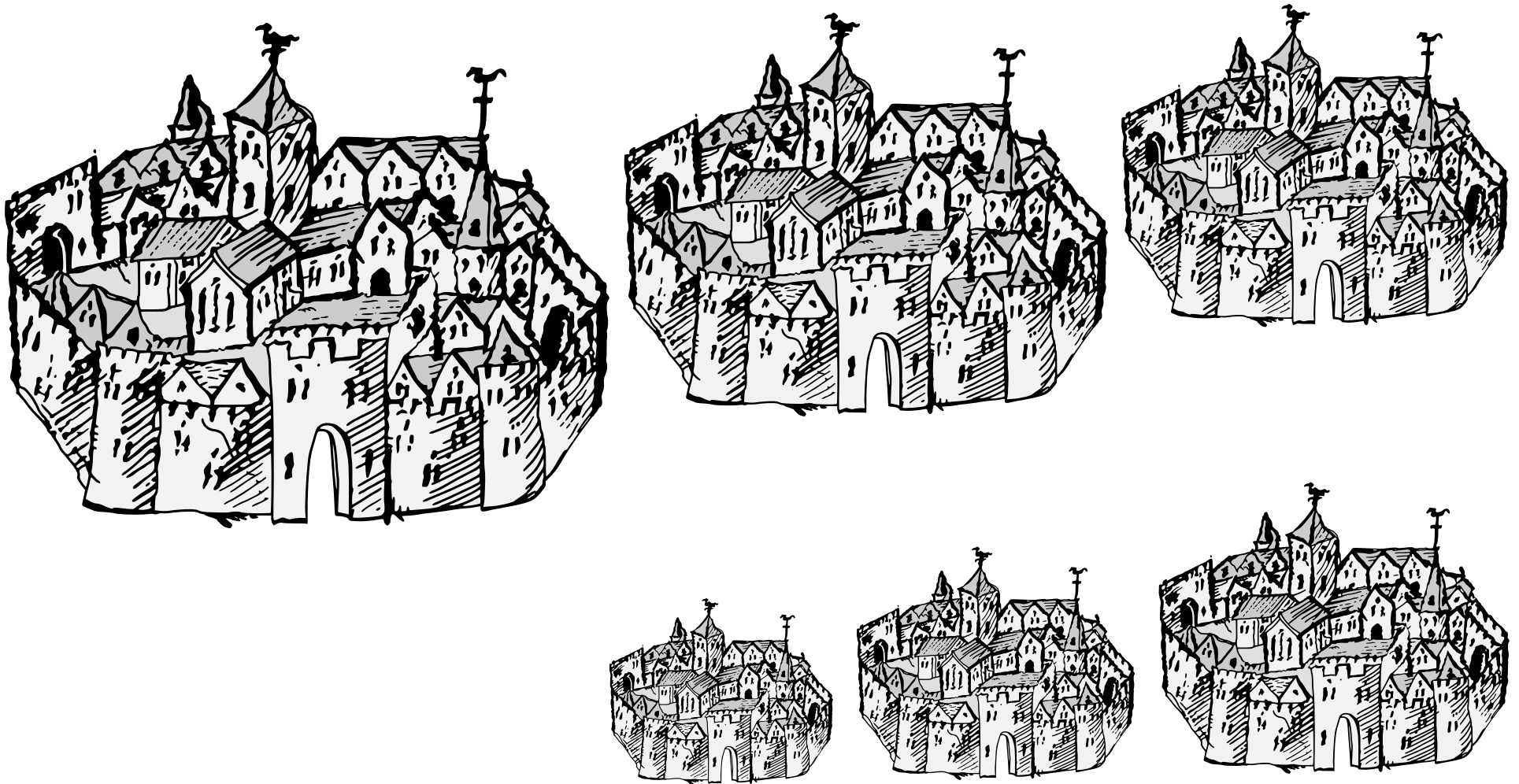

A group of non-military buildings enclosed by a wall.

Default orientation: upright. No proper coloration.

Source: A Display of Heraldry. Artist unknown. (Folio 85v.)

Adapted by Wahrija of St Christina the Astonishing.

City (3) 17.96

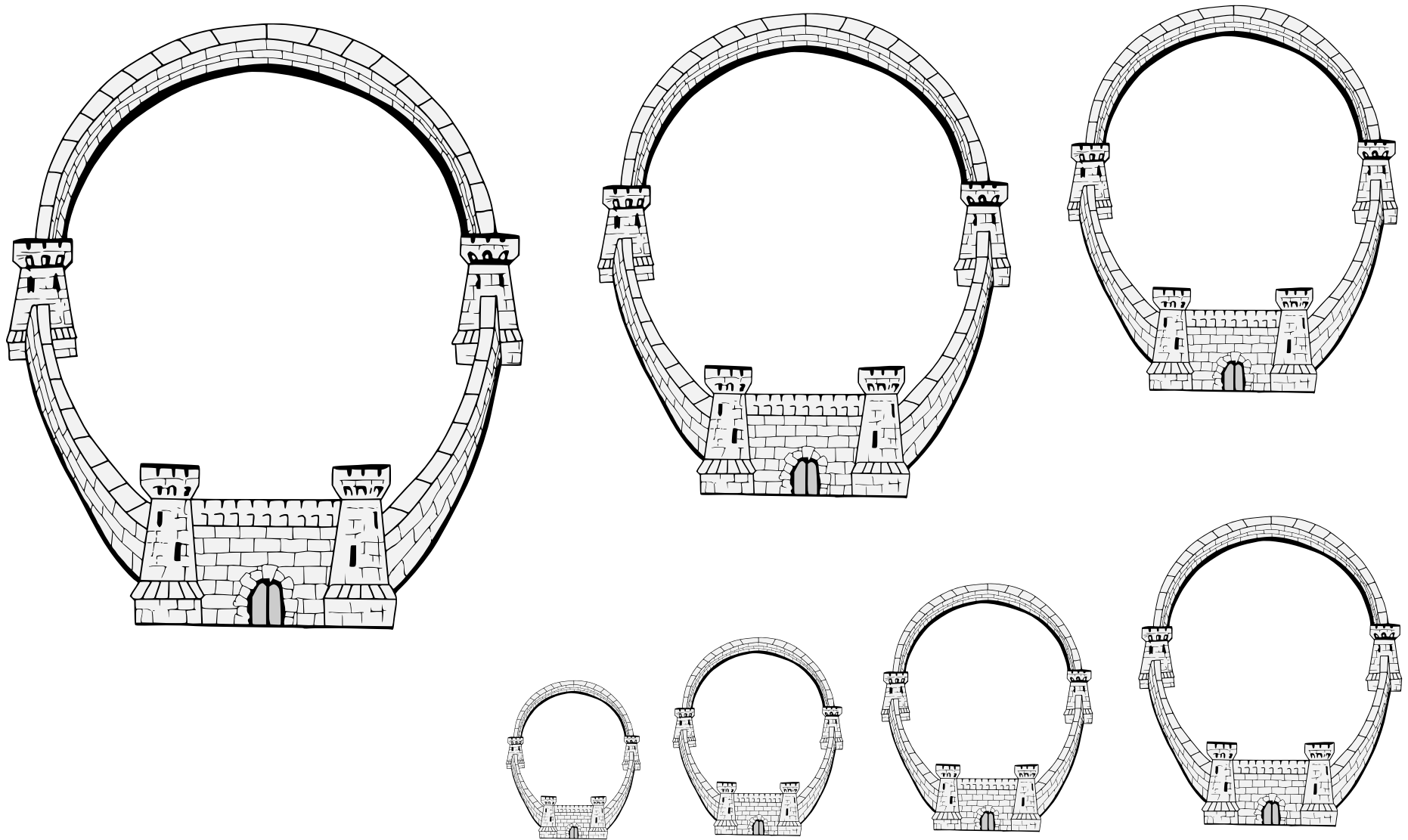

A circular wall set with towers and gate, as might be built to protect a town.

Default orientation: in annulo. No proper coloration.

Source: The Arms of Saffron Walden. Artist unknown.
Adapted by Wahrija of St Christina the Astonishing.

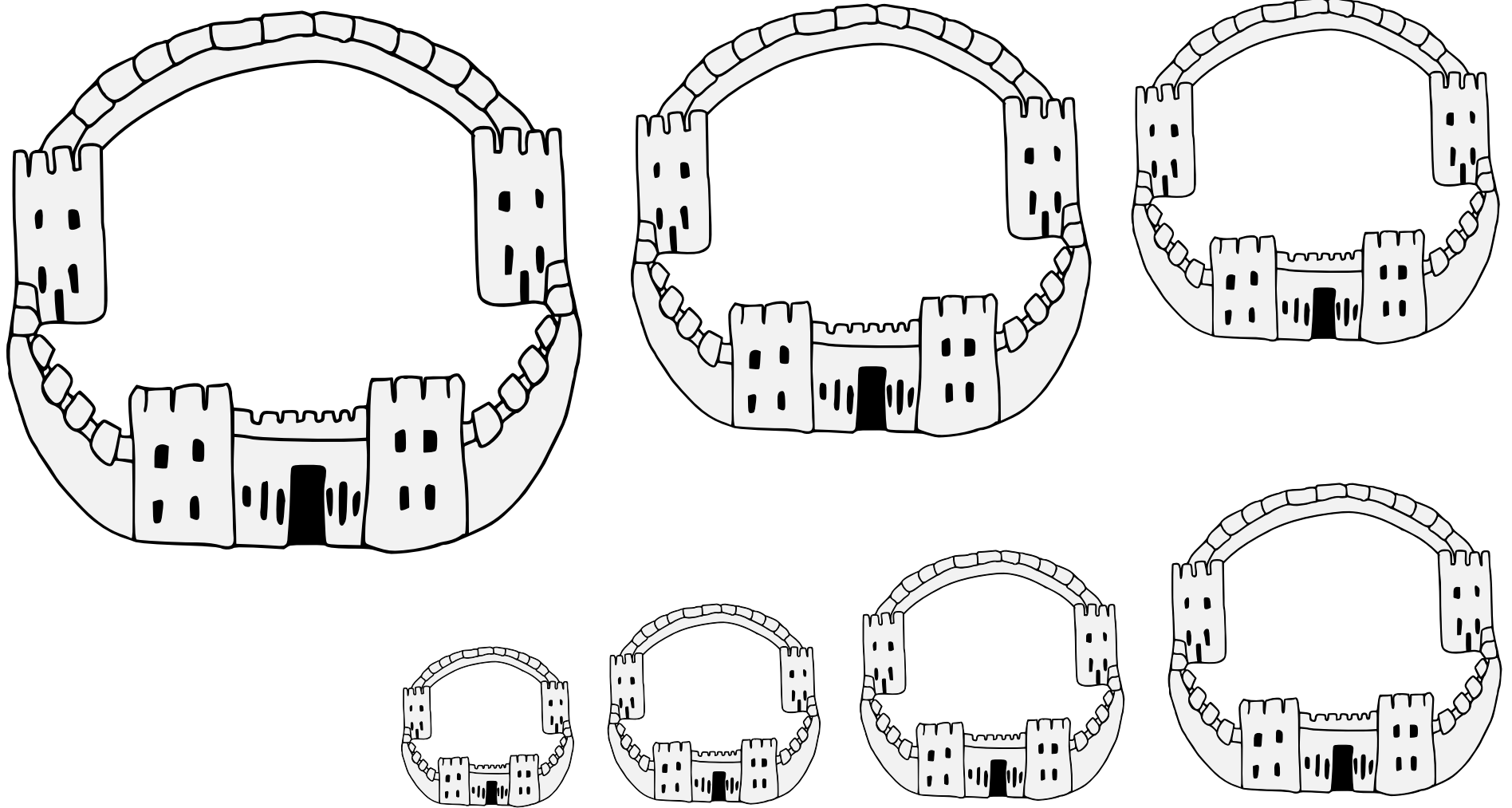

A circular wall set with towers and gate, as might be built to protect a town.

Default orientation: in annulo. No proper coloration.

Source: The Seal of Saffron Walden. (Dated 1549.) Artist unknown.

Adapted by Wahrija of St Christina the Astonishing.

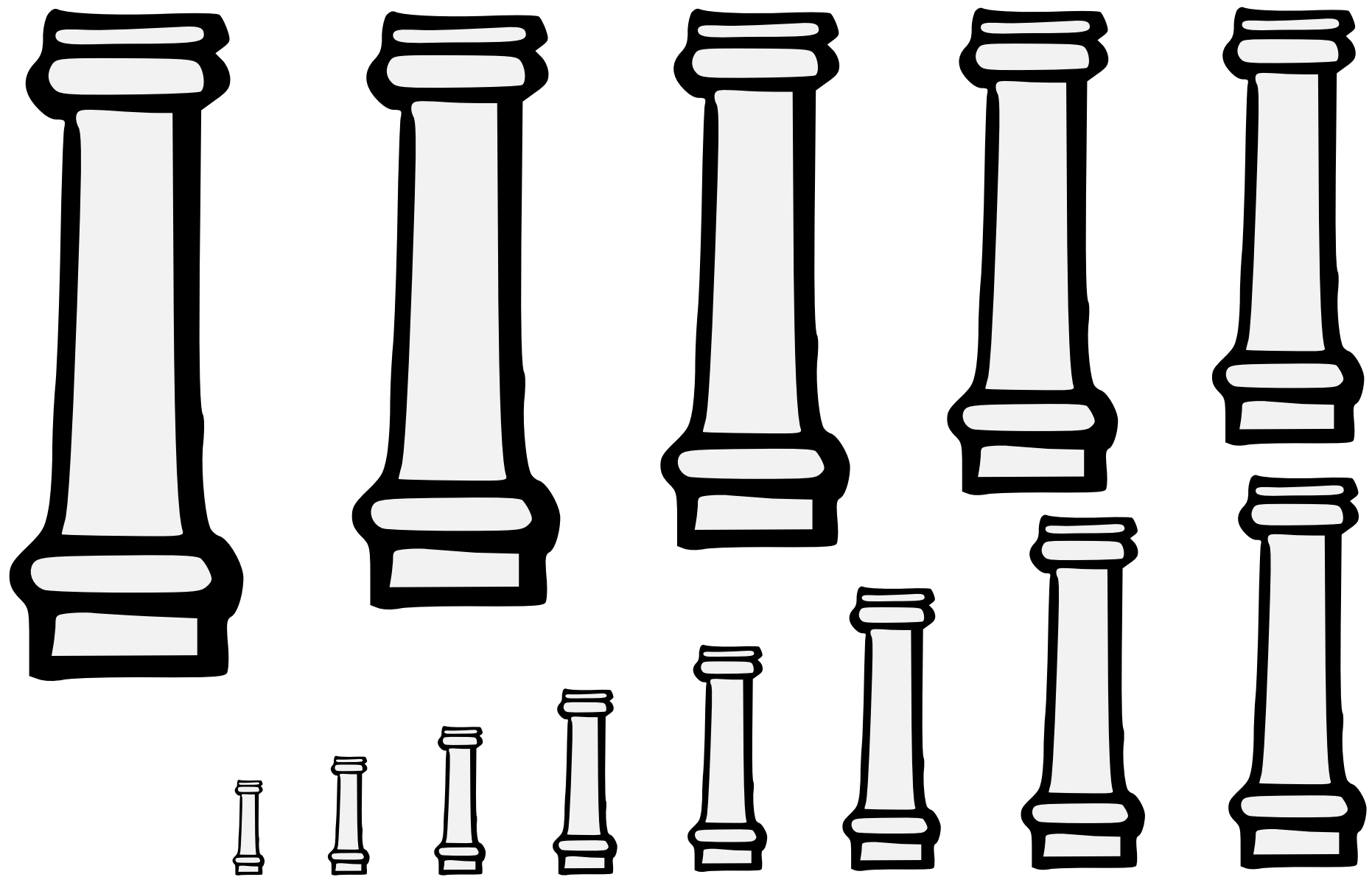

An architectural pillar.

Default orientation: palewise. No proper coloration unless blazoned a “stone column” (argent).

Source: The Art of Heraldry. Artist: Unknown.

Column (1) 17.99

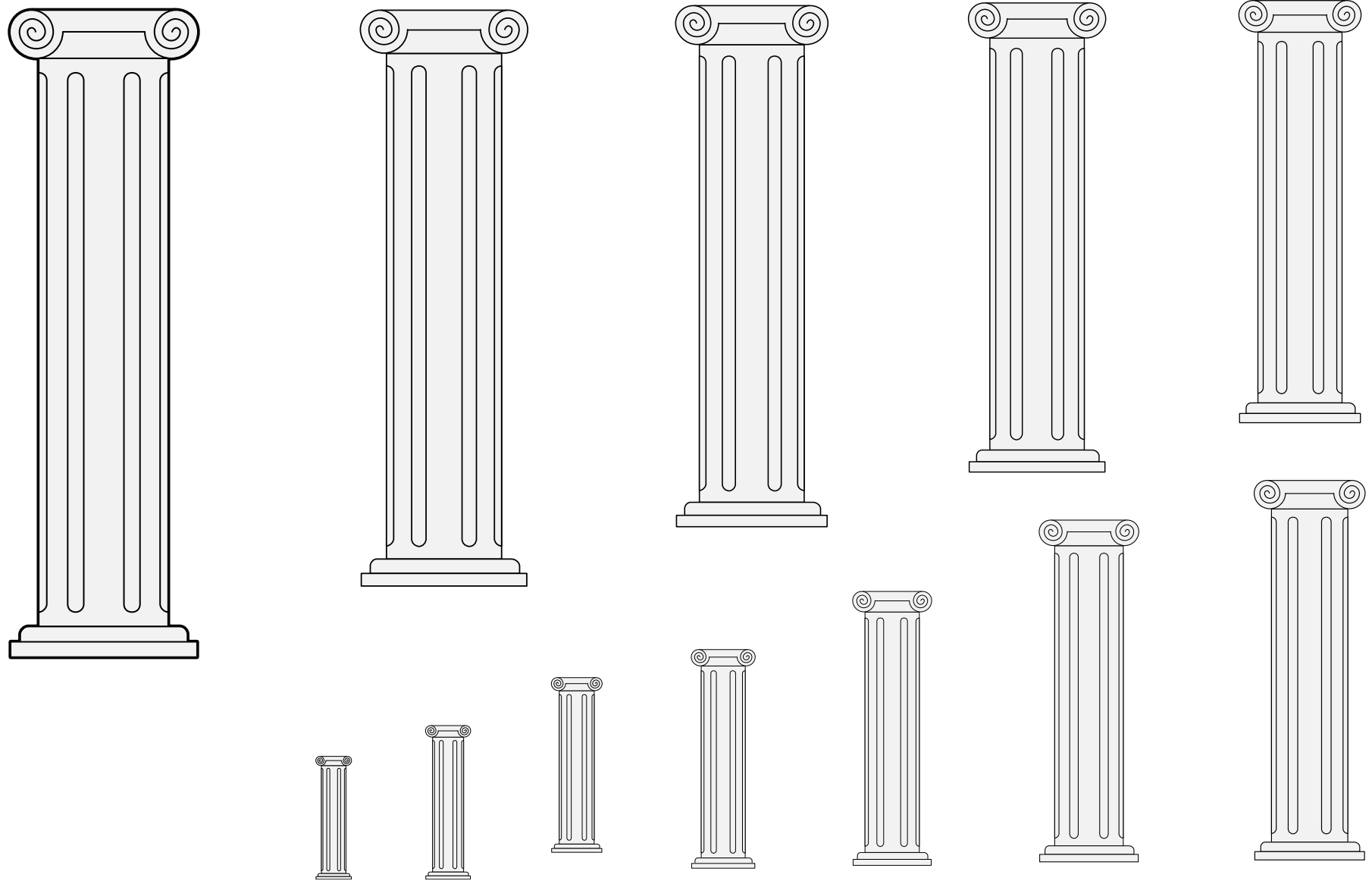

An architectural pillar.

Default orientation: palewise. No proper coloration unless blazoned a “stone column” (argent).

Source: OpenClipArt. Artist: OpenHeraldry.

Column (2) 17.100

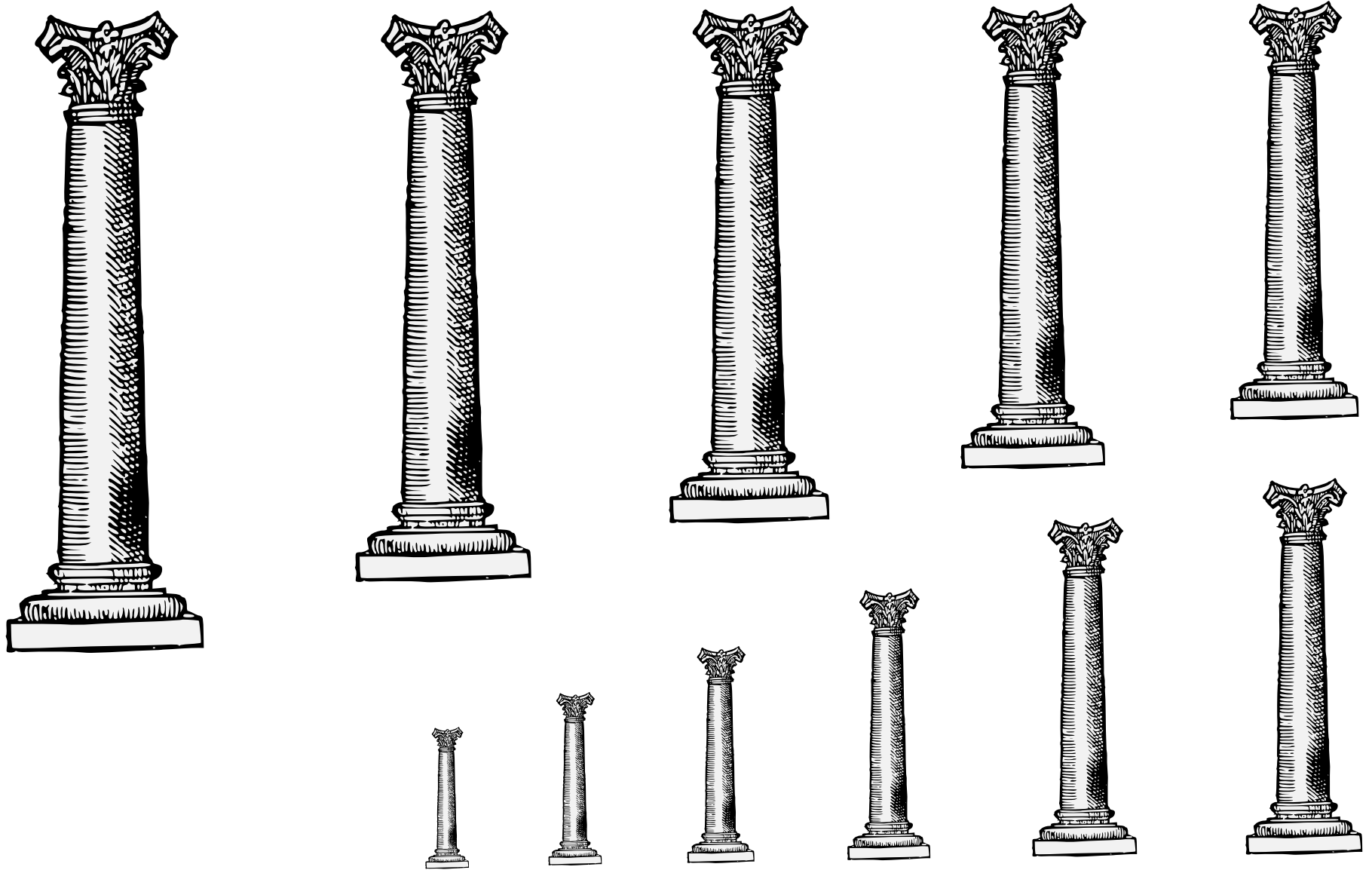

An architectural pillar.

Default orientation: palewise. No proper coloration unless blazoned a “stone column” (argent).

Source: Le Blason Des Armoiries. Artist: Jérôme de Bara.

Column (3) 17.101

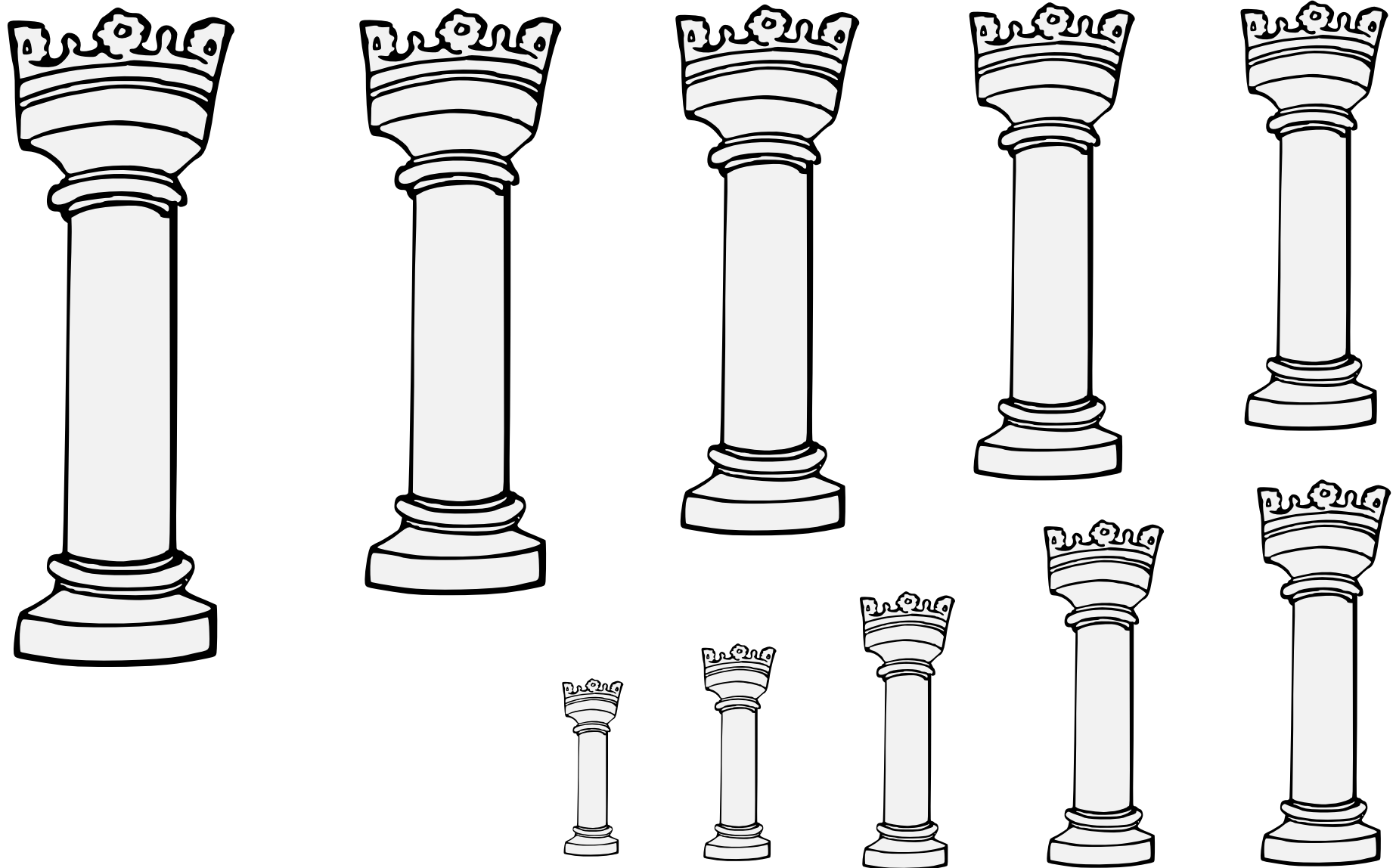

An architectural pillar.

Default orientation: palewise. No proper coloration unless blazoned a “stone column” (argent).

Source: Stemmario Trivulziano. Artist: Gian Antonio da Tradate.

Column (4) 17.102

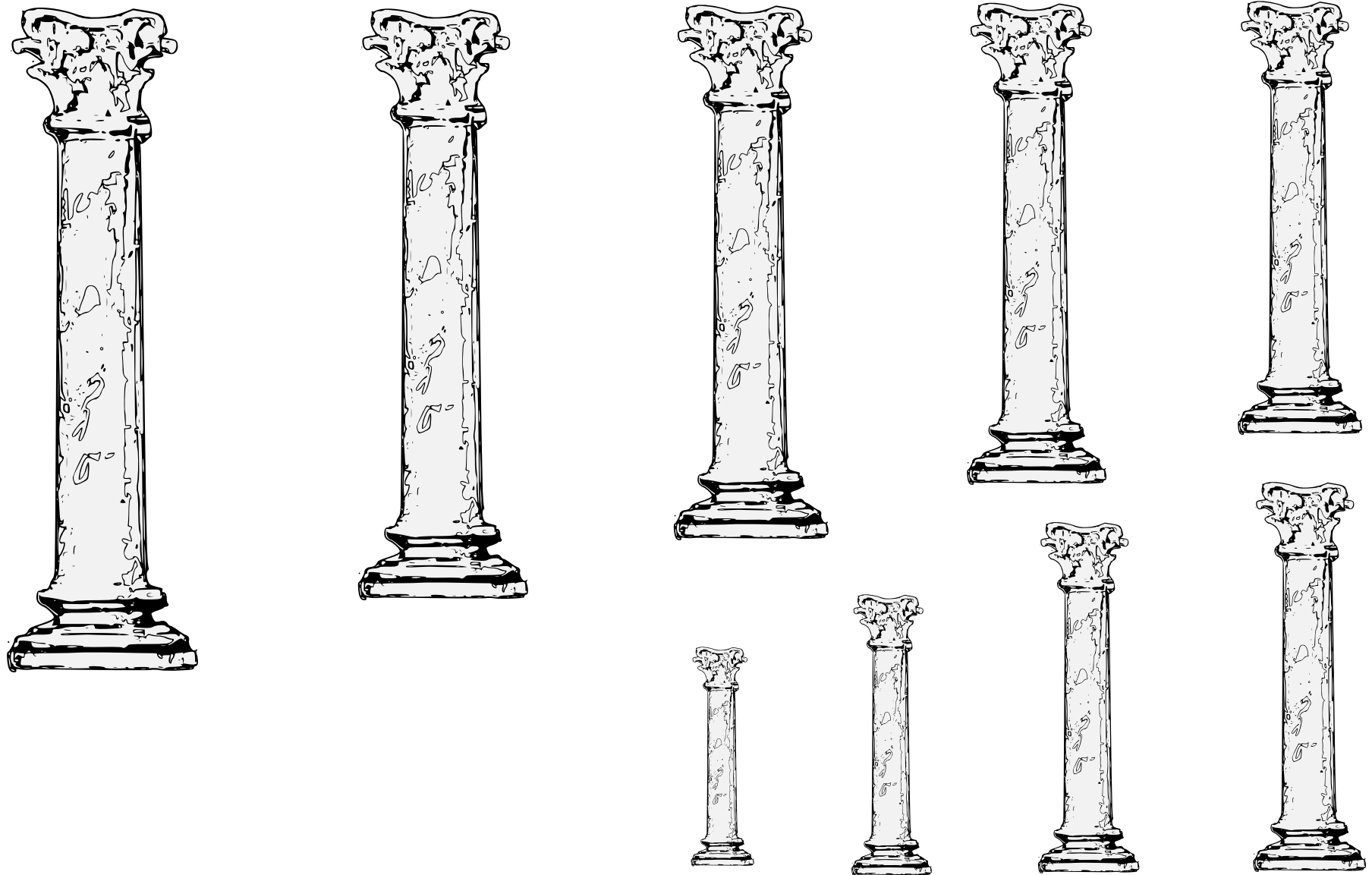

An architectural pillar.

Default alignment: palewise. No proper coloration unless blazoned a “stone column” (argent).

Source: Insignia Venetorum Nobilium II. Artist unknown.
(From the arms of Cholona, folio 97.)

Column (5) 17.103

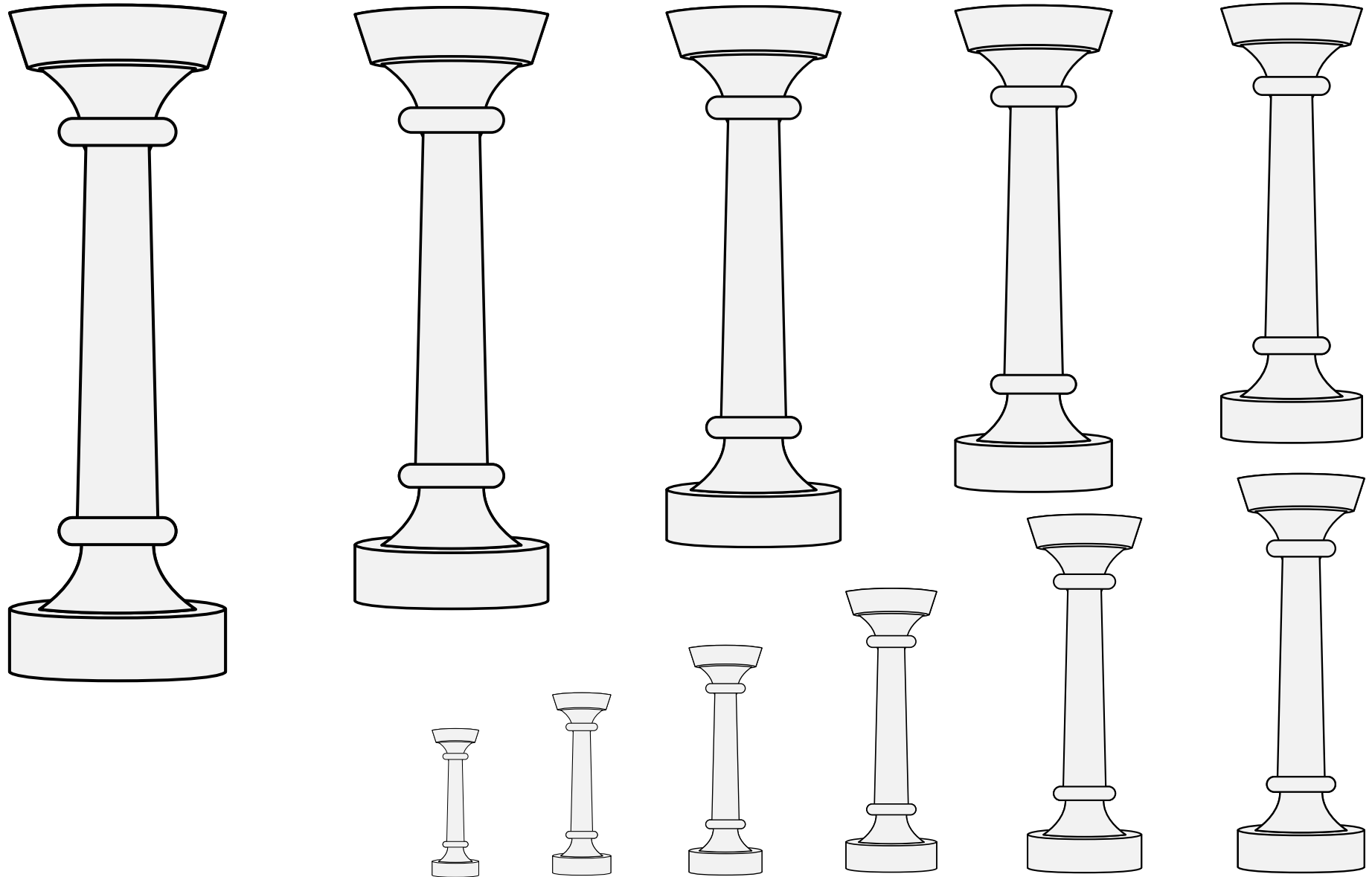

An architectural pillar.

Default orientation: palewise. No proper coloration unless blazoned a “stone column” (argent).

Source: Wappenbuch of the Holy Roman Empire. Artist unknown. (Page 690.)

Column (6) 17.104

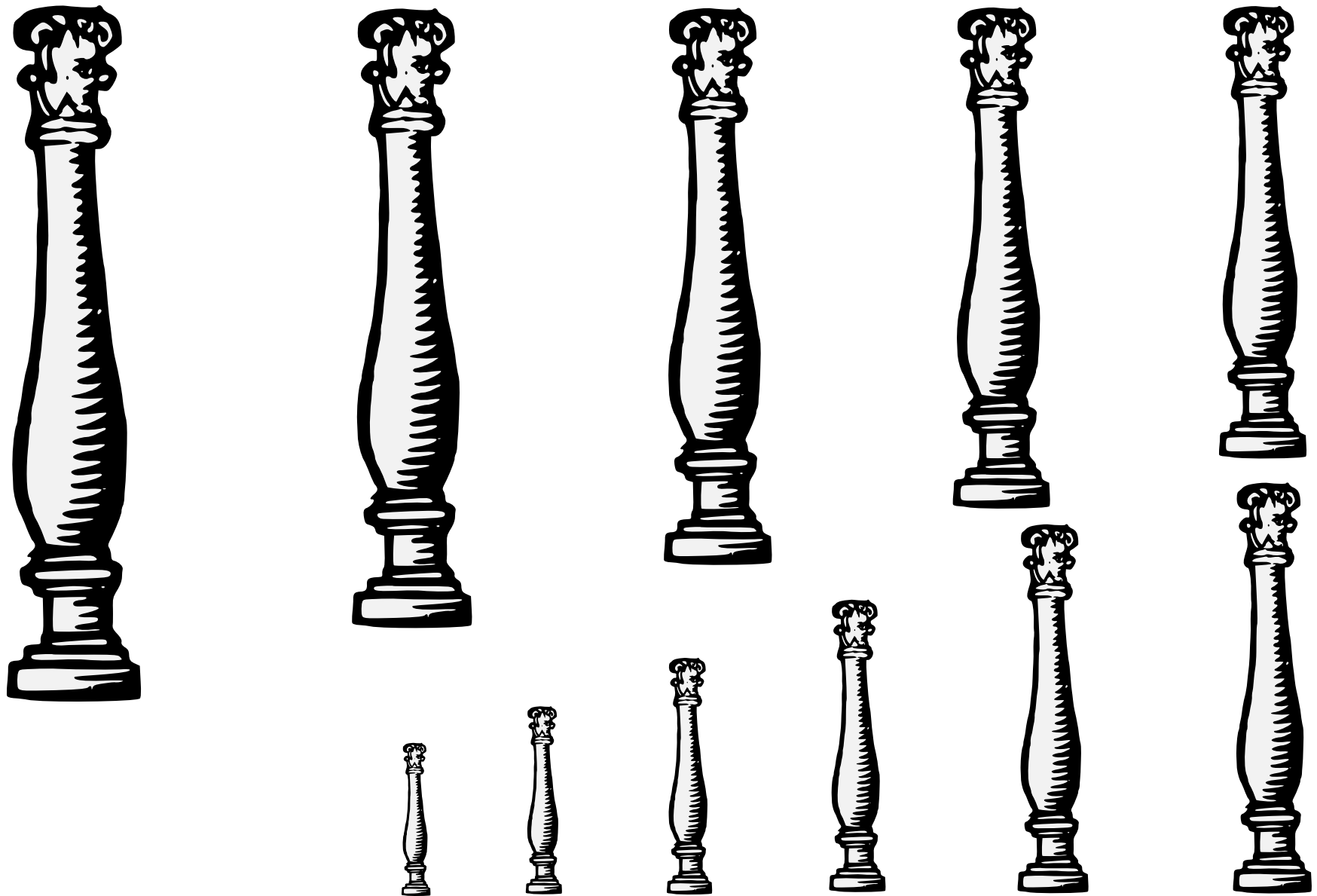

An architectural pillar.

Default orientation: palewise. No proper coloration unless blazoned a “stone column” (argent).

Source: Schlesisches Wappenbuch. Artist unknown. (Page 195.)

Column (7) 17.105

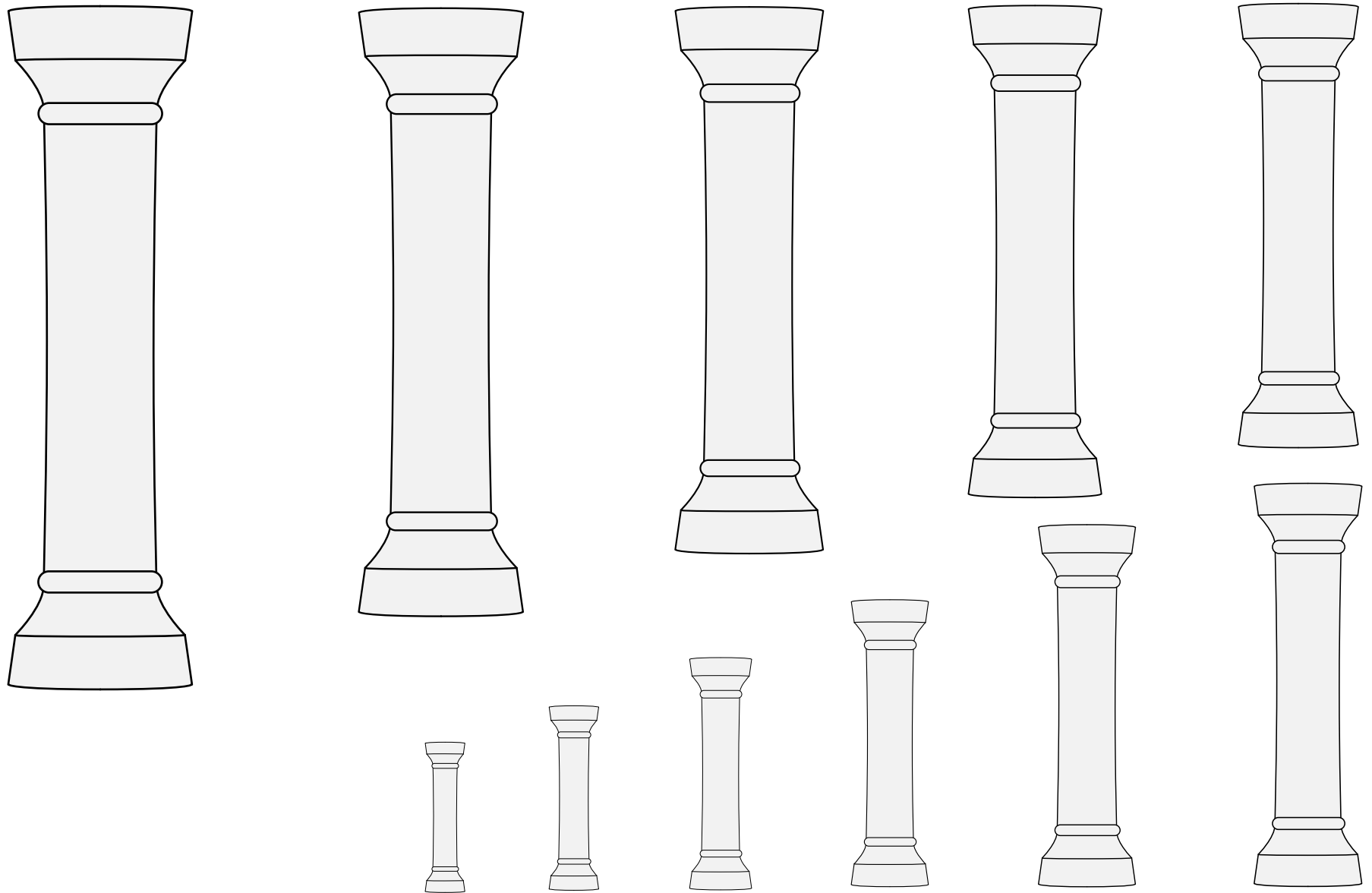

An architectural pillar.

Default orientation: palewise. No proper coloration unless blazoned a "stone column" (argent).

Column (8) 17.106

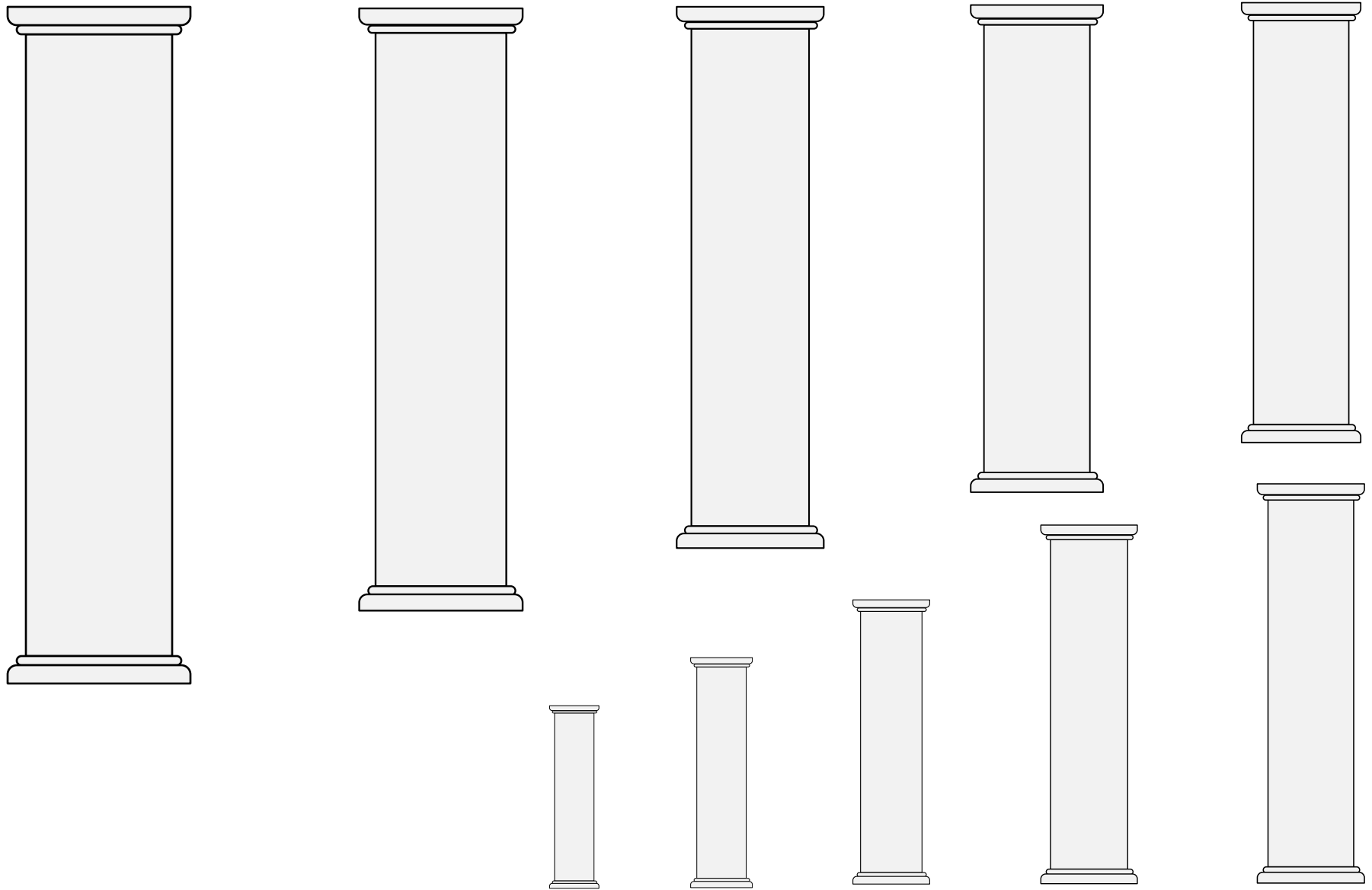

An architectural pillar.

Default orientation: palewise. No proper coloration unless blazoned a “stone column” (argent).

Source: Insignia Nobilium Urbis Romae. Artist unknown. (Arms of de Paritatis, folio 89.)

Column (9) 17.107

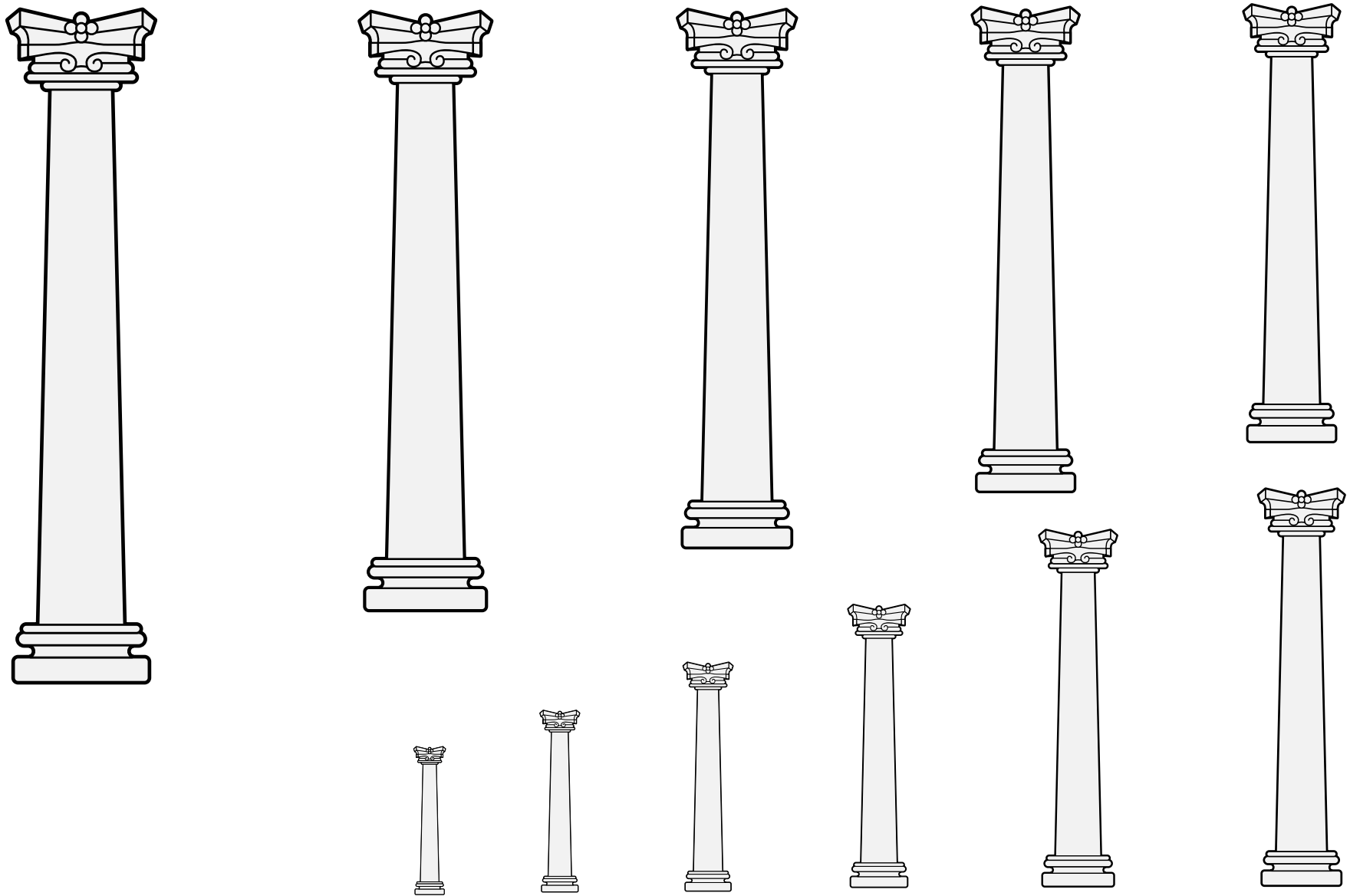

An architectural pillar.

Default orientation: palewise. No proper coloration unless blazoned a “stone column” (argent).

Source: Insignia Pontificum Romanorum et Cardinalium I. Artist unknown. (Folio 117r.)

Column (10) 17.108

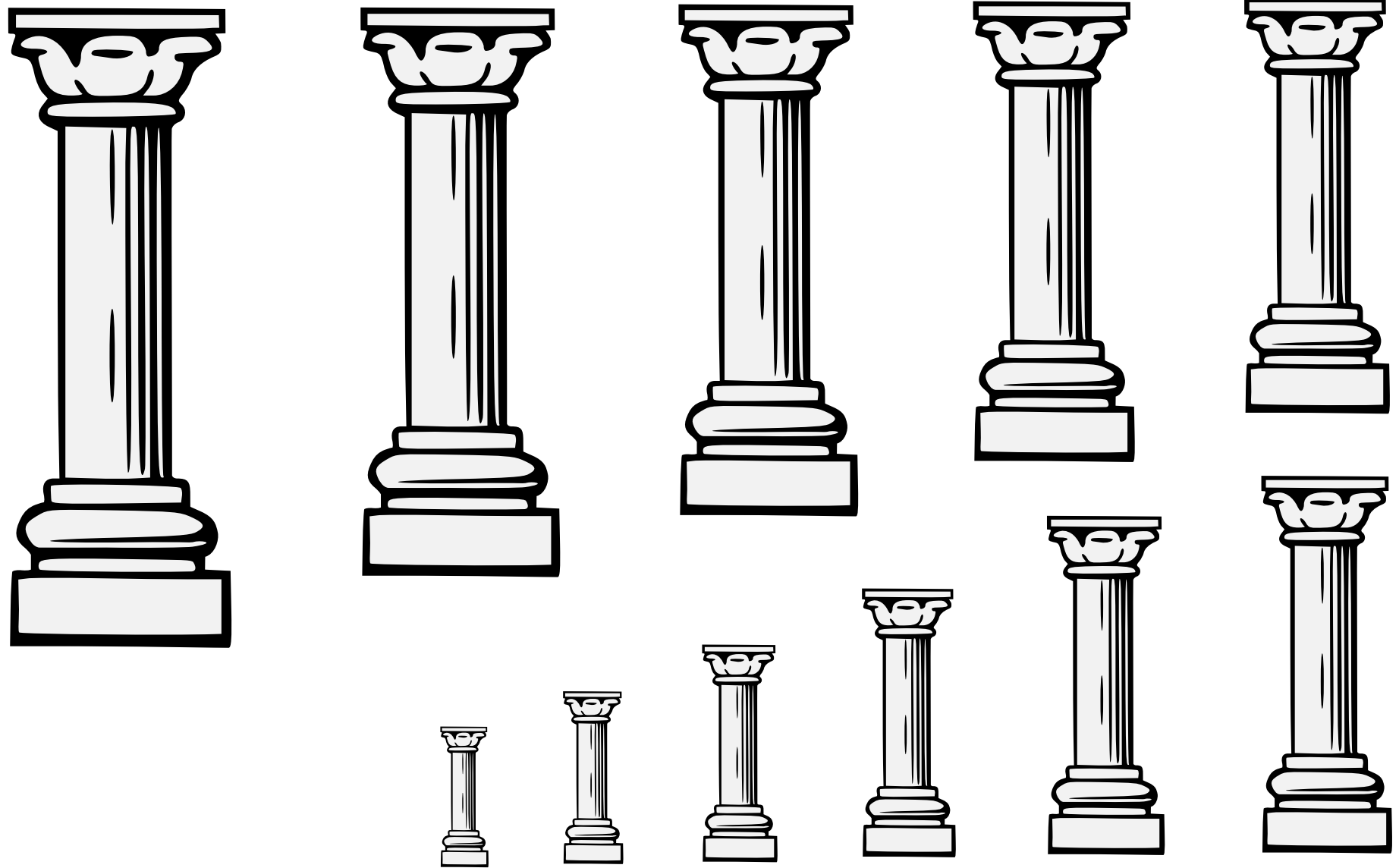

An architectural pillar.

Default orientation: palewise. No proper coloration unless blazoned a “stone column” (argent).

Source: Vocabulaire-Atlas Héraldique. Artist unknown. (Plate XVI.)

Column (11) 17.109

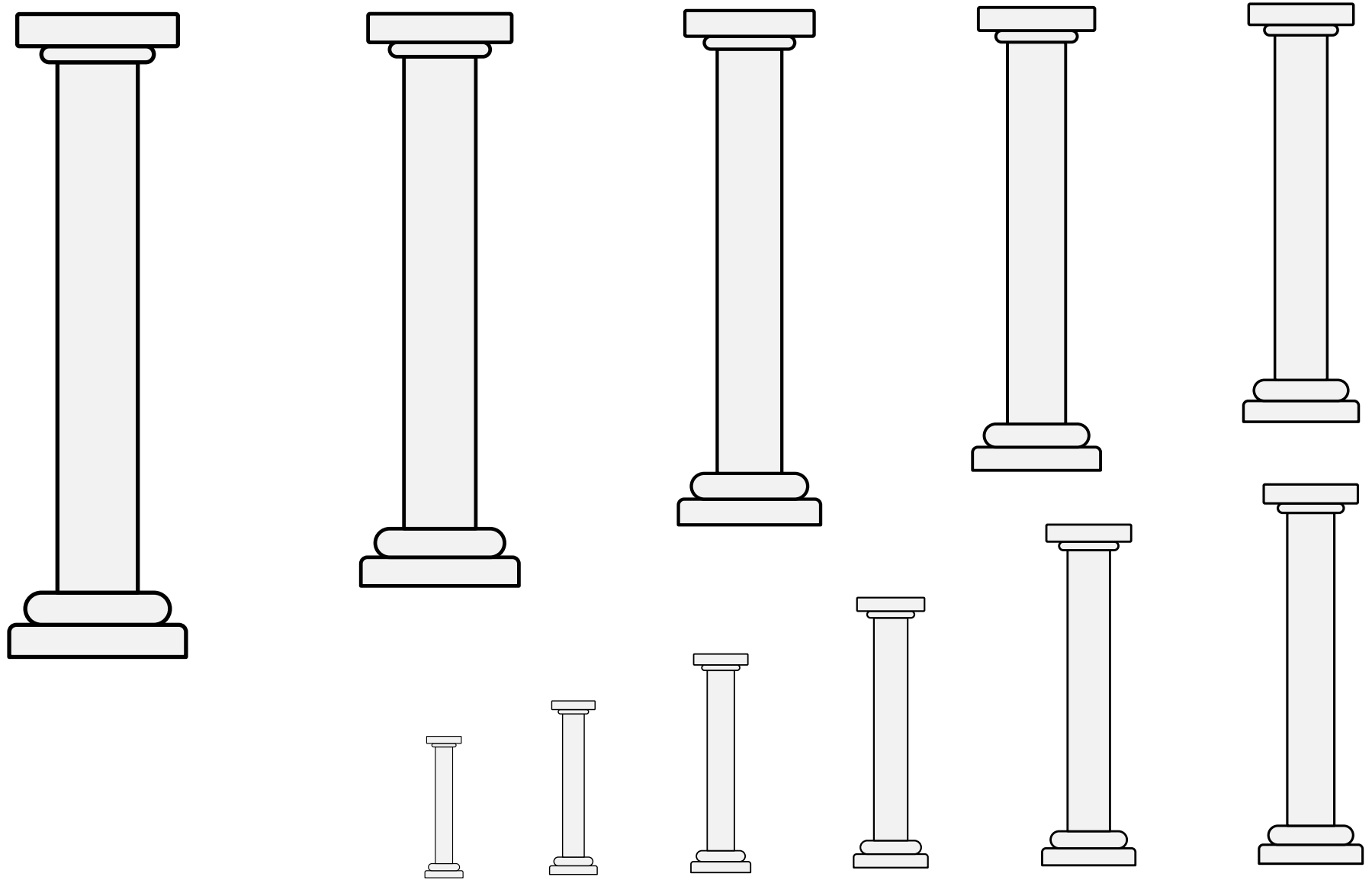

An architectural pillar.

Default orientation: palewise. No proper coloration unless blazoned a “stone column” (argent).

Source: A Glossary of Terms Used in Heraldry. Artist: James or Irene Parker.

Column (12) 17.110

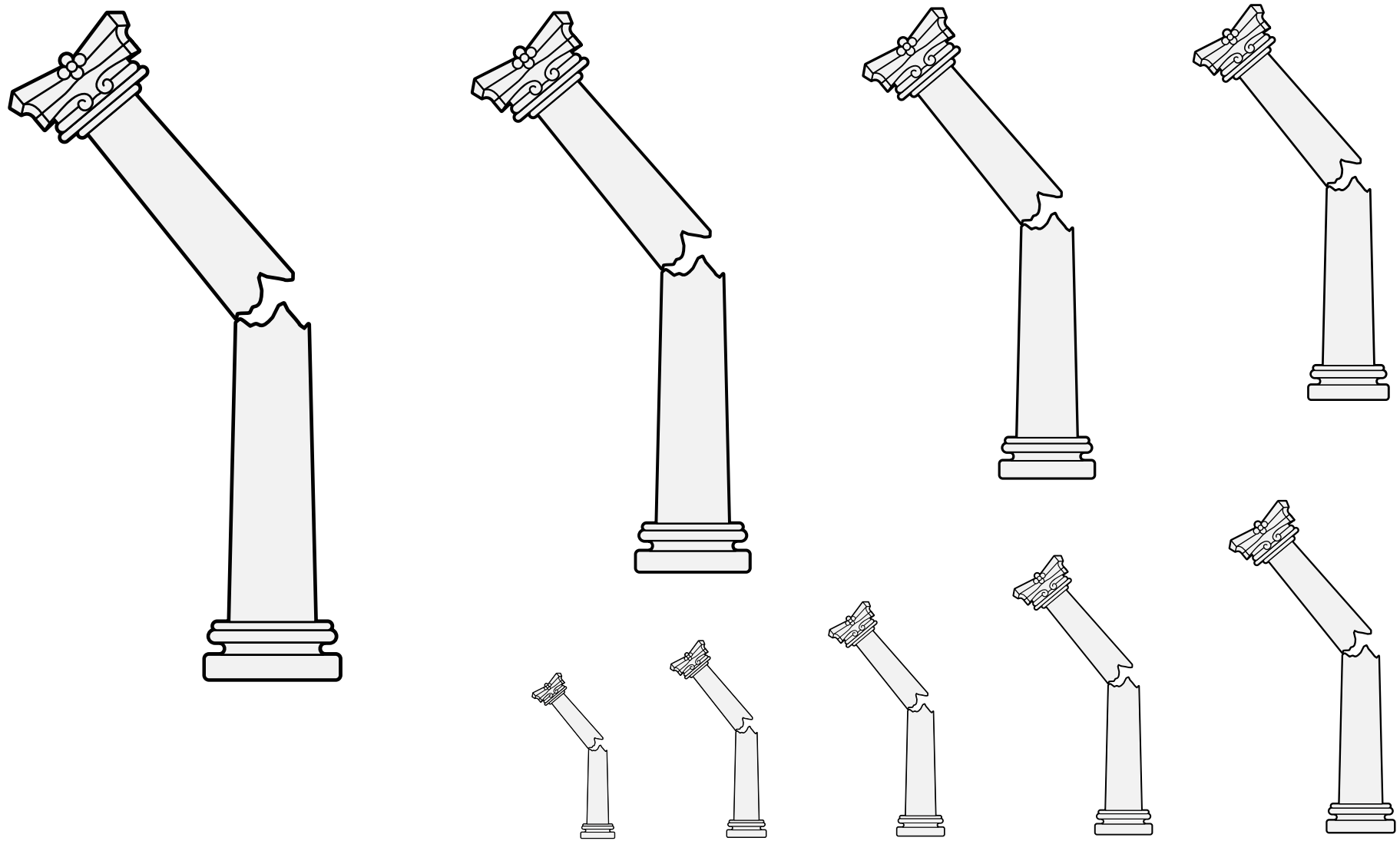

An architectural pillar.

Default orientation: palewise. No proper coloration unless blazoned a “stone column” (argent).

Source: Insignia Pontificum Romanorum et Cardinalium I.
Artist unknown. (Folio 117r.) Adapted by Mathghamhain Ua Ruadháin.

Column, Broken 17.111

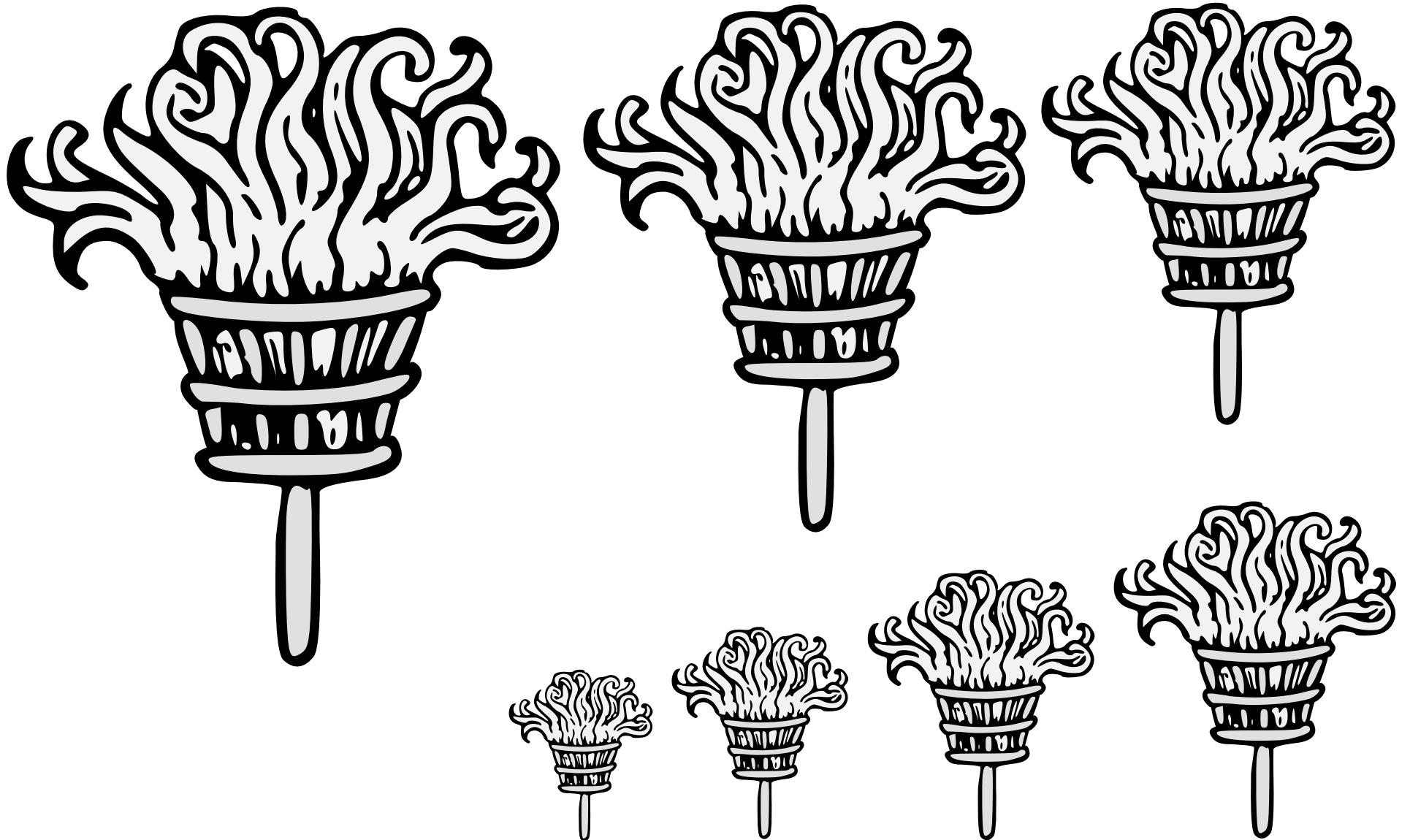

A metal torch basket, spewing flames.

Default orientation: flame to chief. No proper coloration.

Source: A Complete Guide to Heraldry. Artist: Graham Johnston.
Adapted by Mathghamhain Ua Ruadháin.

Cresset (1) 17.112

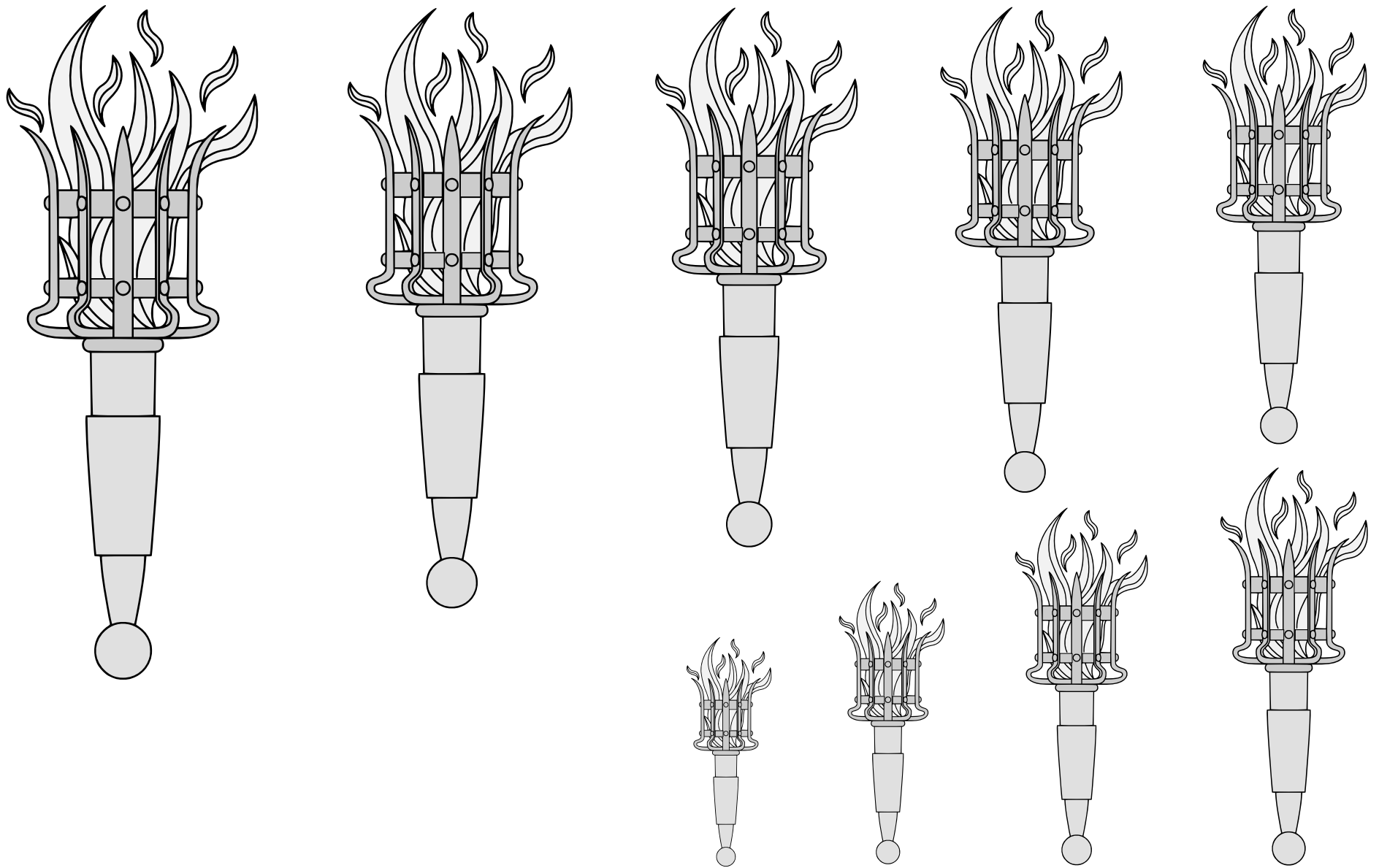

A metal torch basket, spewing flames.

Default orientation: flame to chief. No proper coloration.

Source: Sledgehammer. Artist: Grimwulf Harland.

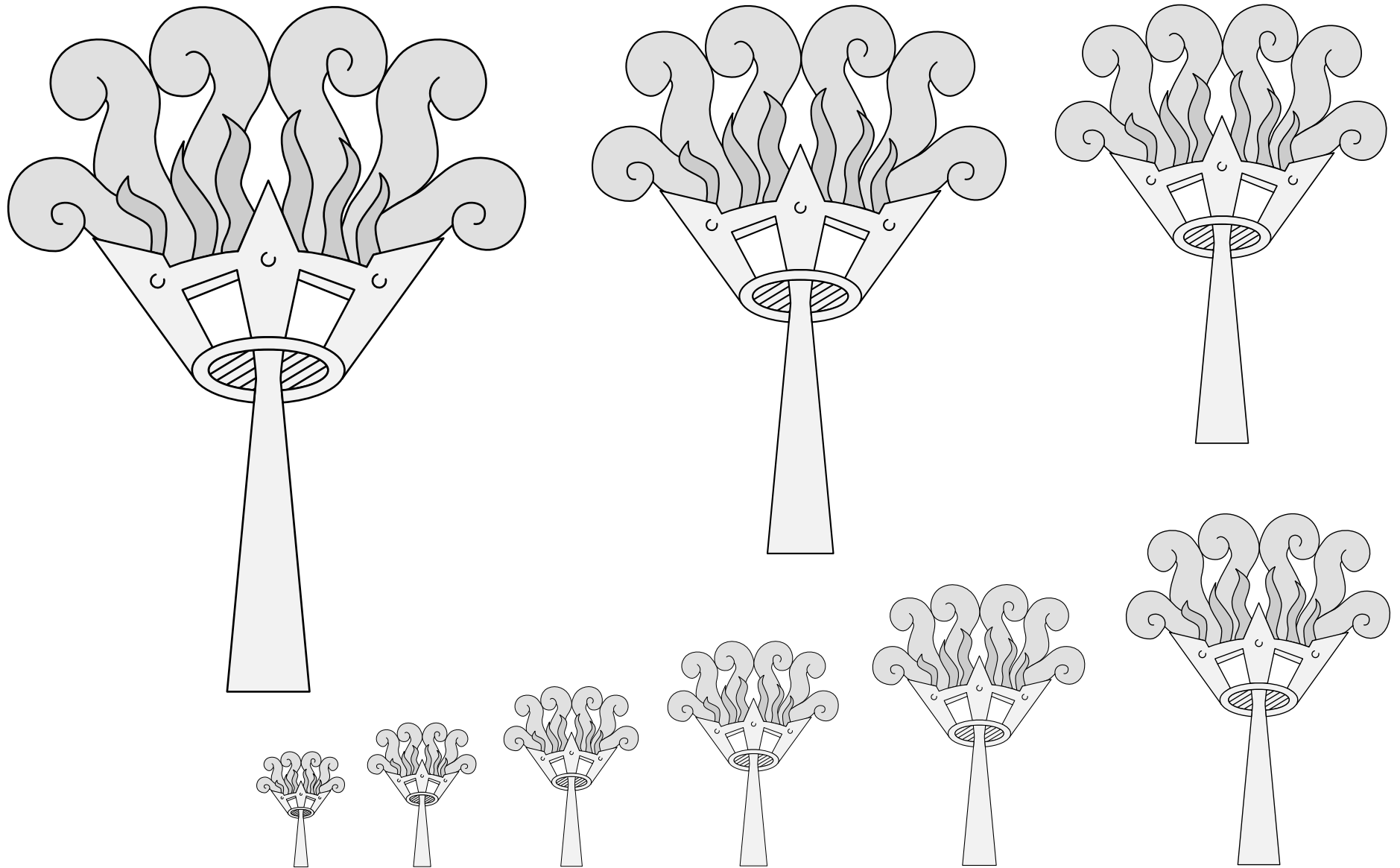

A metal torch basket, spewing flames.

Default orientation: flame to chief. No proper coloration.

Source: Walter Roll. Artist unknown. (Badge of Henry V.)

Cresset (3) 17.114

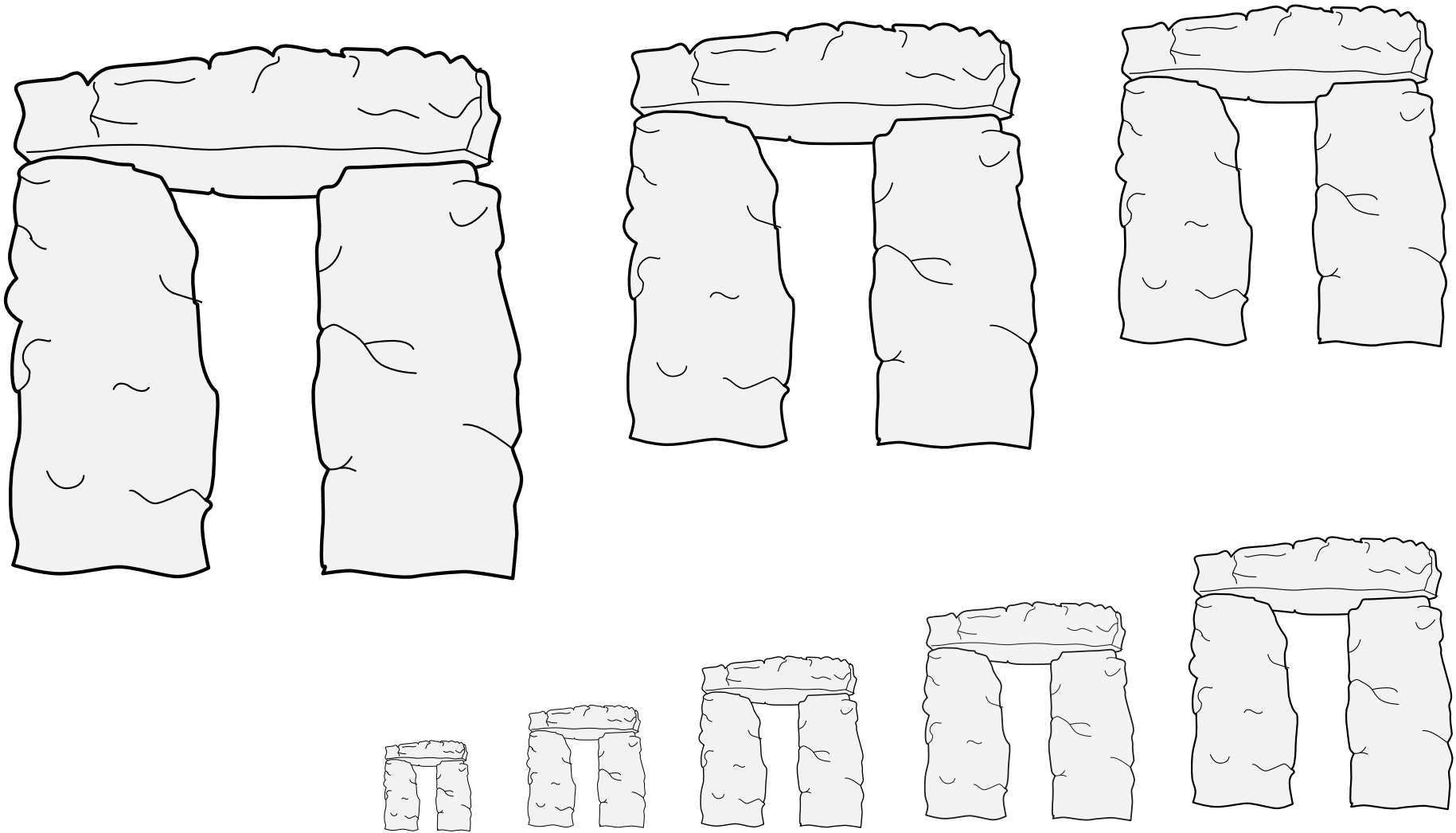

An ancient structure of giant stones, sometimes blazoned a “trilithon.”
Default orientation: upright. No proper coloration.

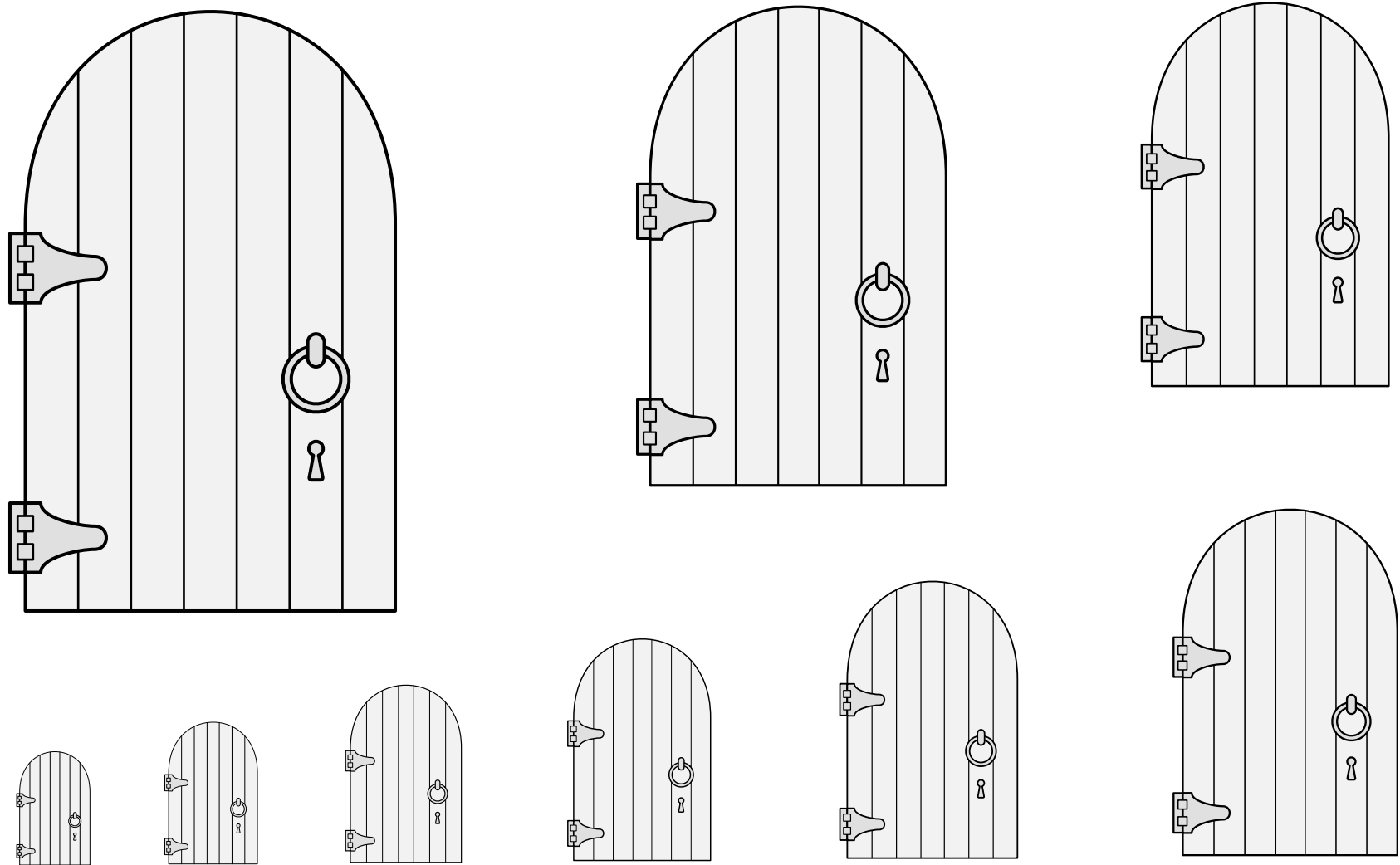

An entryway that may be opened or closed to control access to a building.

Default orientation: upright. Proper coloration: only if material is blazoned; a wooden item is brown.

Door (1) 17.116

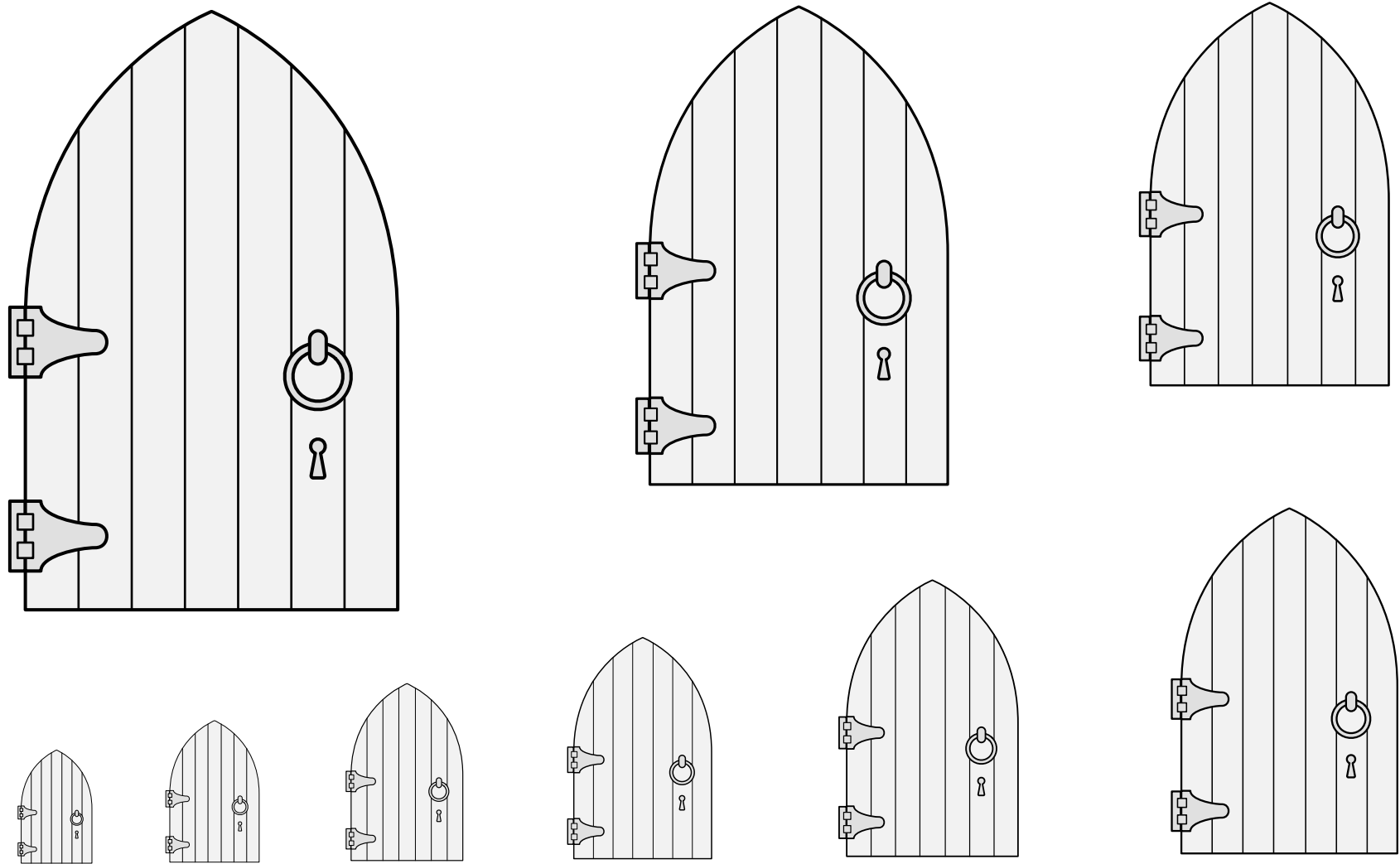

An entryway that may be opened or closed to control access to a building.

Default orientation: upright. Proper coloration: only if material is blazoned; a wooden item is brown.

Door (2) 17.117

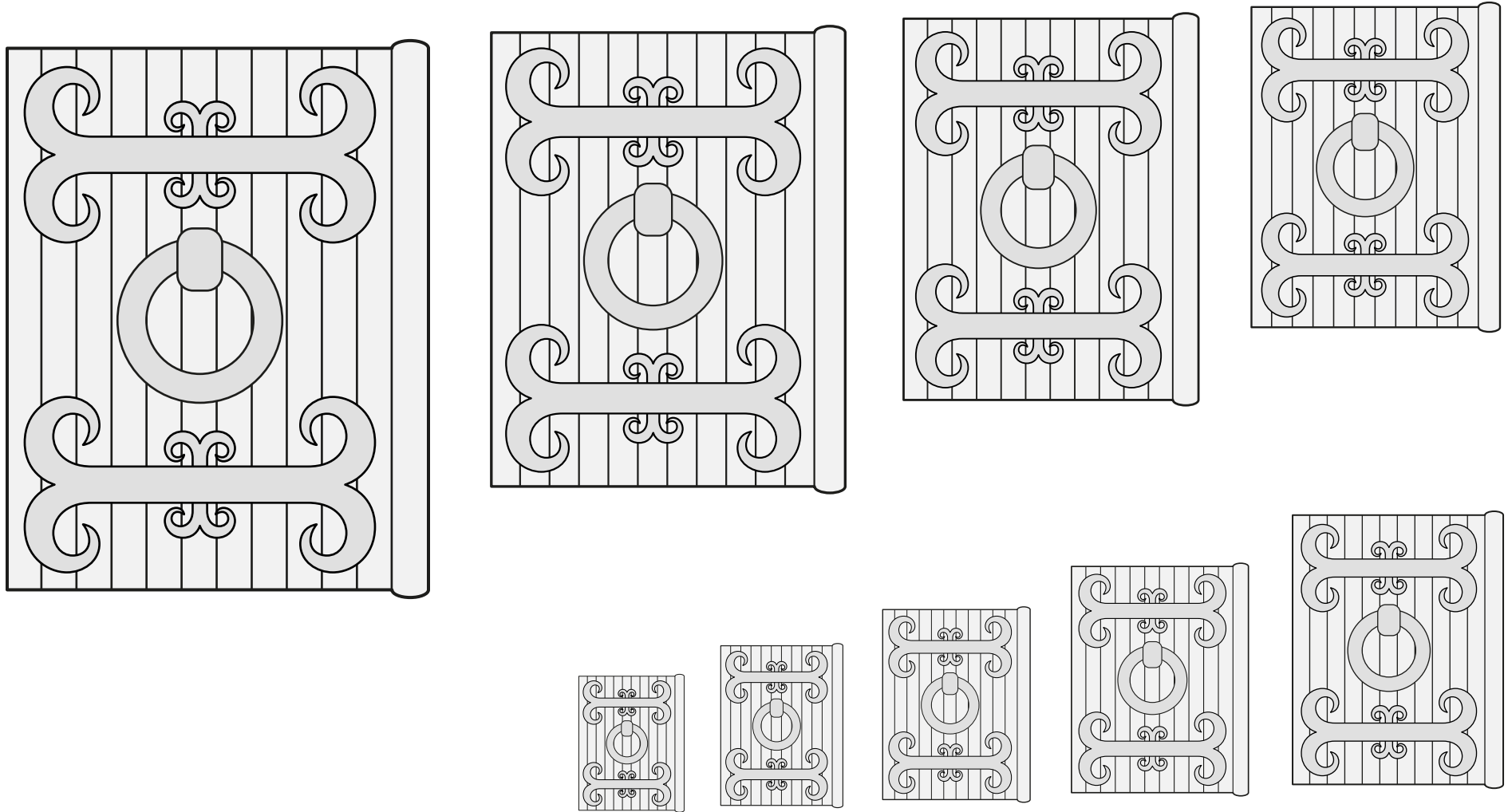

An entryway that may be opened or closed to control access to a building.

Default orientation: upright. Proper coloration: only if material is blazoned; a wooden item is brown.

Source: WappenWiki. Artist: Joakim Spuller.

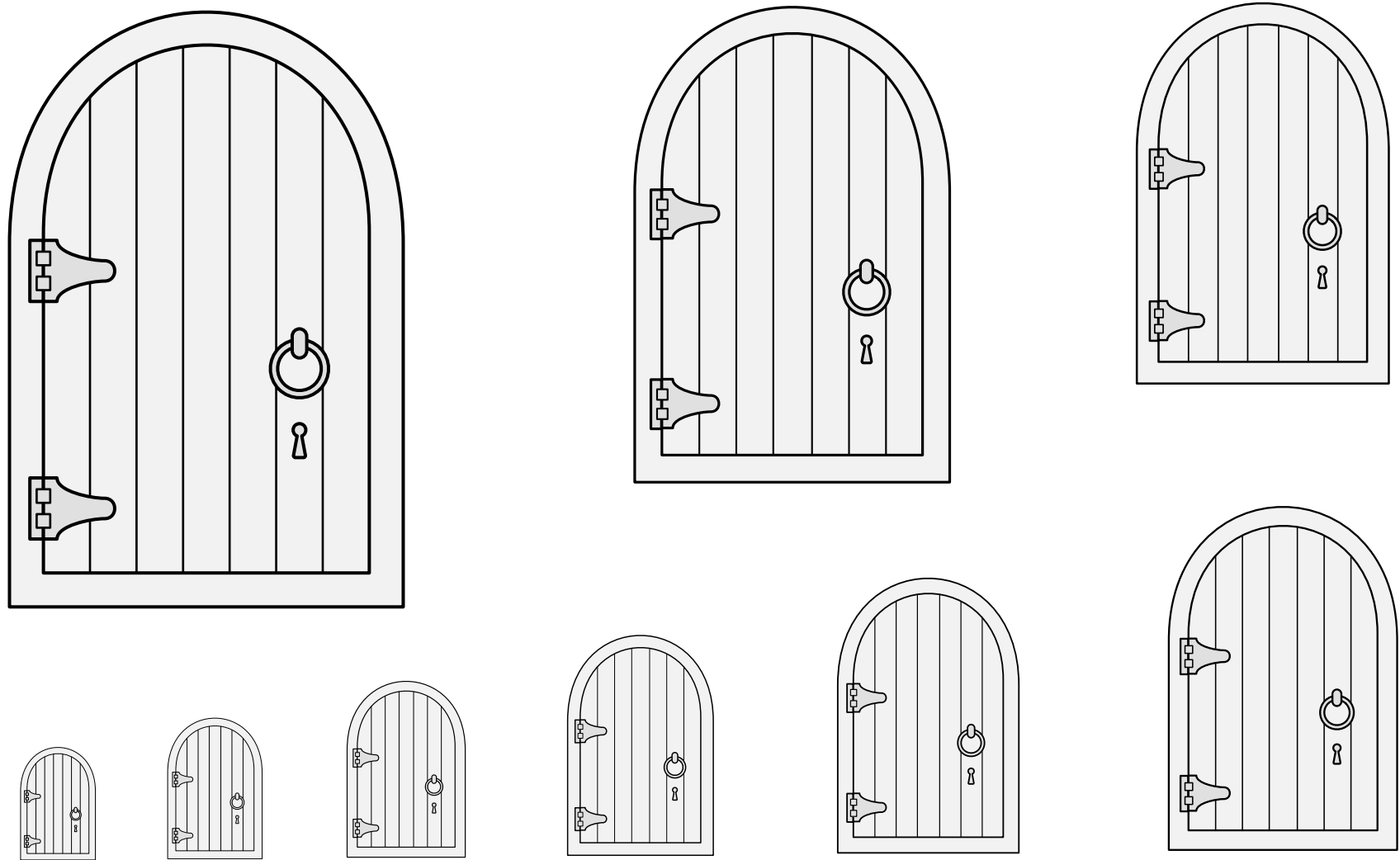

An entryway that may be opened or closed to control access to a building.

Default orientation: upright.

Proper coloration: only if material is blazoned; a wooden item is brown.

Door, Arched (1) 17.119

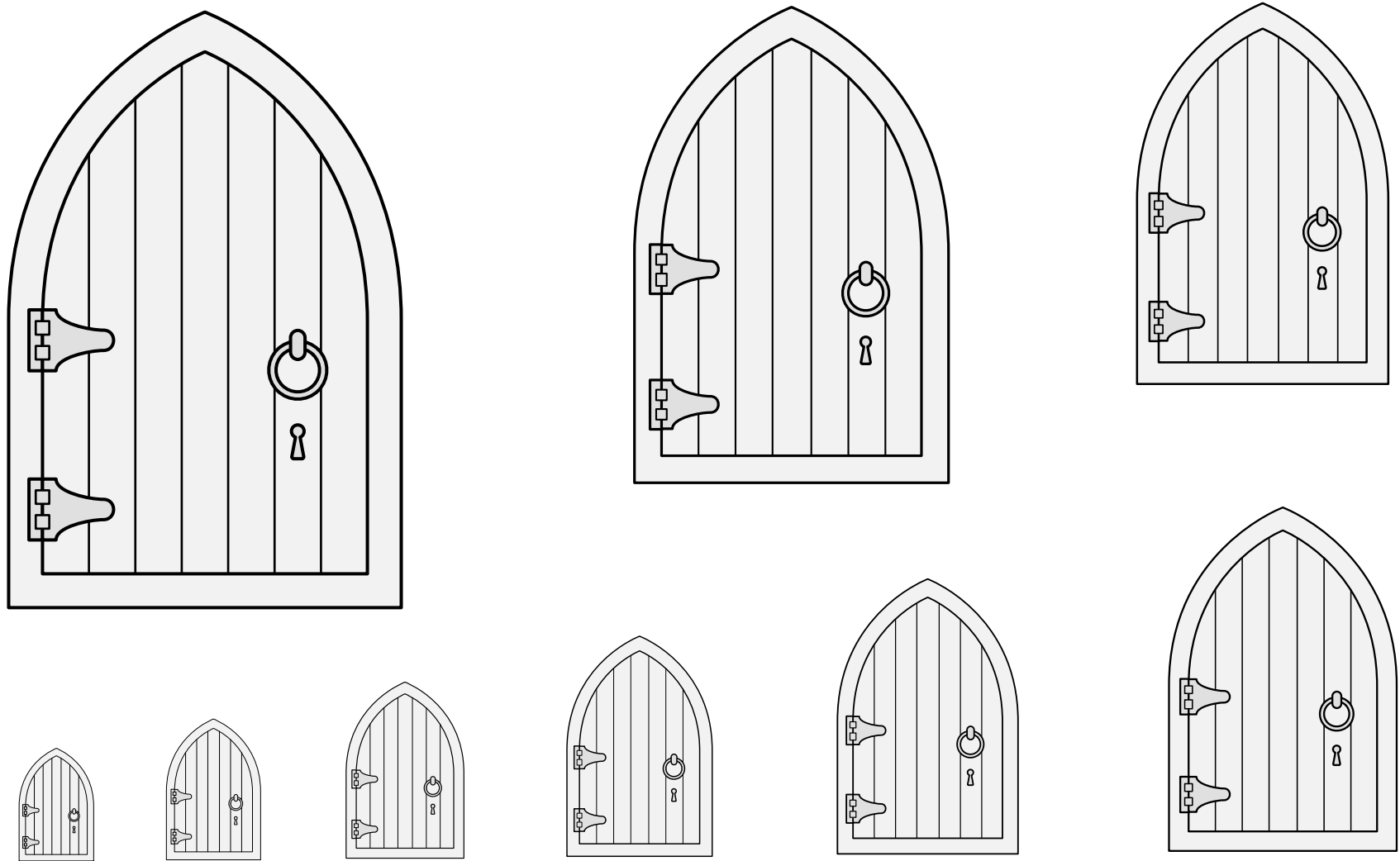

An entryway that may be opened or closed to control access to a building.

Default orientation: upright.

Proper coloration: only if material is blazoned; a wooden item is brown.

Door, Arched (2) 17.120

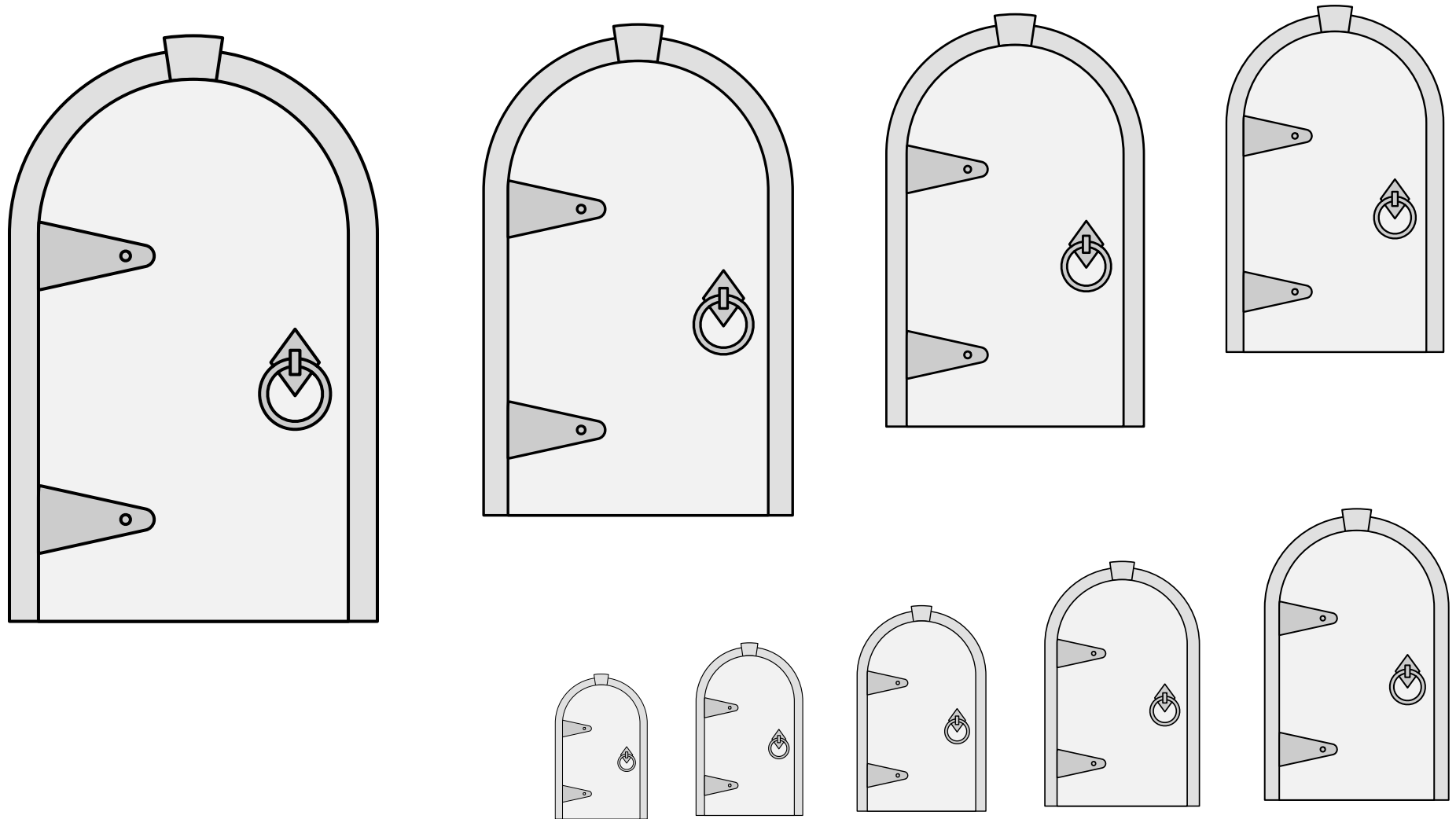

An entryway that may be opened or closed to control access to a building.

Default orientation: upright.

Proper coloration: only if material is blazoned; a wooden item is brown.

Door, Arched (3) 17.121

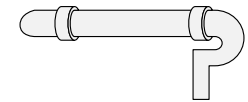
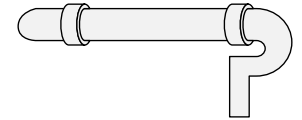
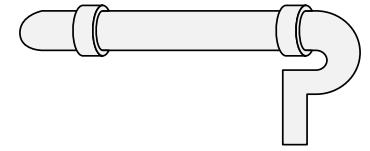
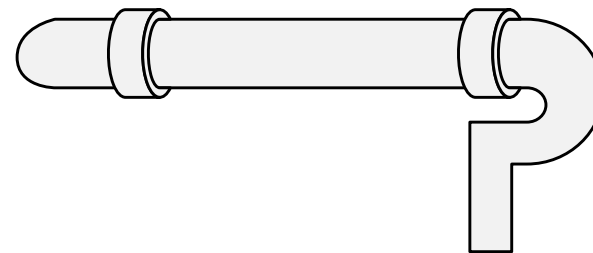
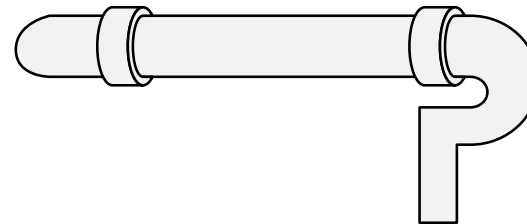
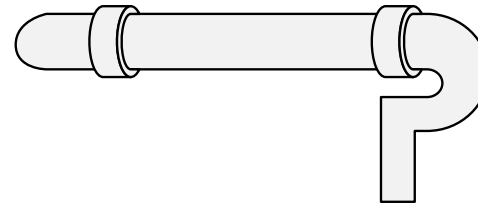
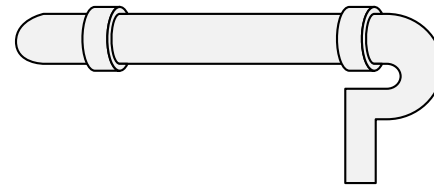
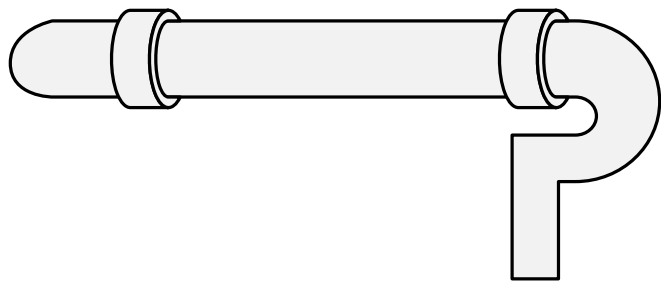
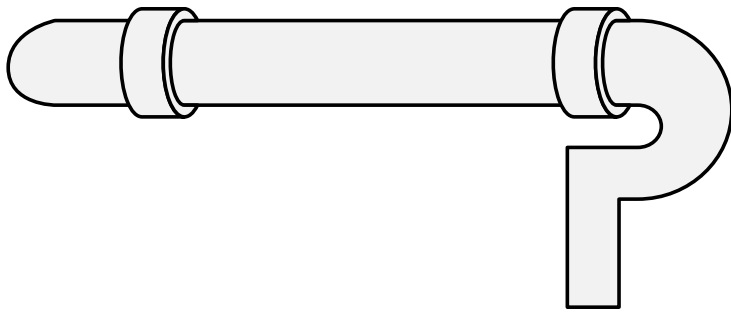
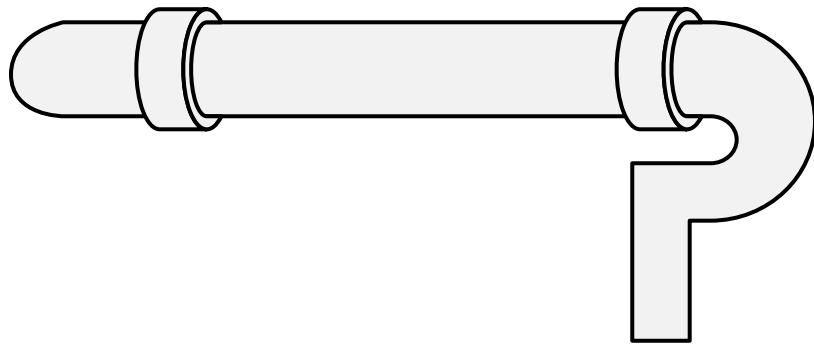

A sliding bar that may be used to lock or unlock a door.

Default orientation: fesswise. No proper coloration.

Source: Insignia Lucensium, Senensium, Pisanorum. Artist unknown.
(Arms of Catenatcci, folio 166r.)

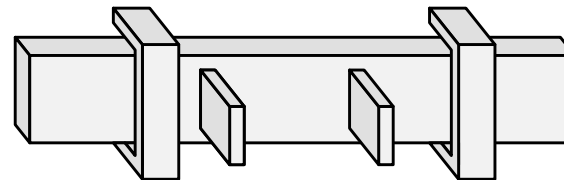
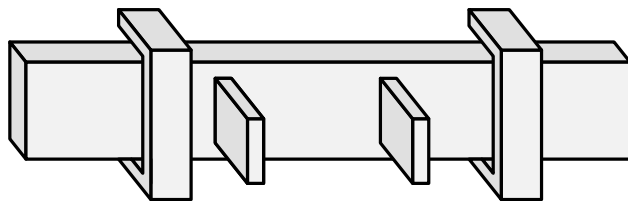
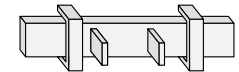
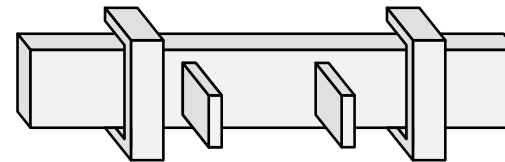
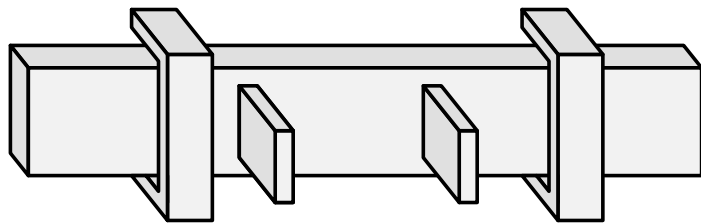
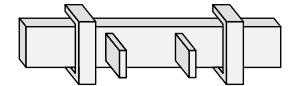
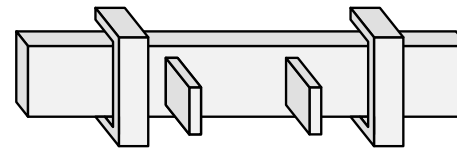
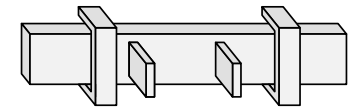
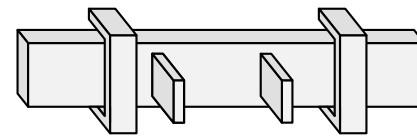
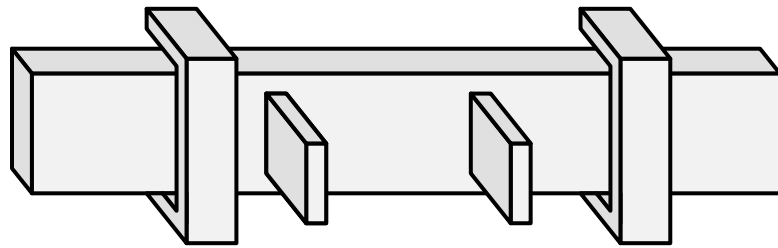

A sliding bar that may be used to lock or unlock a door.

Default orientation: fesswise. No proper coloration.

Source: Coats of Arms of Nuremberg Families. Artist unknown. (Folio 51r.)

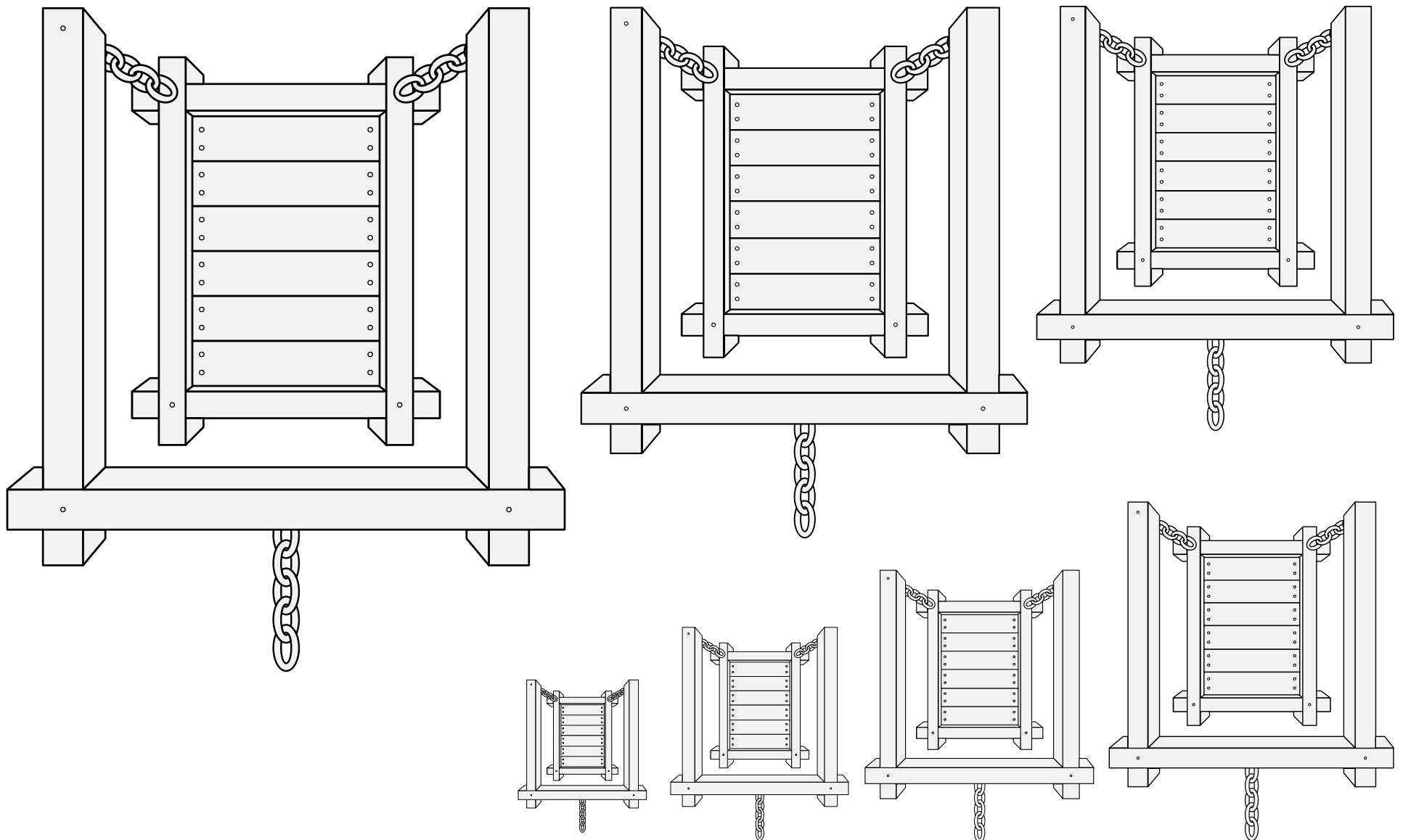

A mobile entrance for a fortified edifice.

Default orientation: seen from above. Proper coloration: brown wood.

Source: Stemmario Trivulziano. Artist: Gian Antonio da Tradate.
(Arms of de Ponte, folio 278.)

Drawbridge (1) 17.124

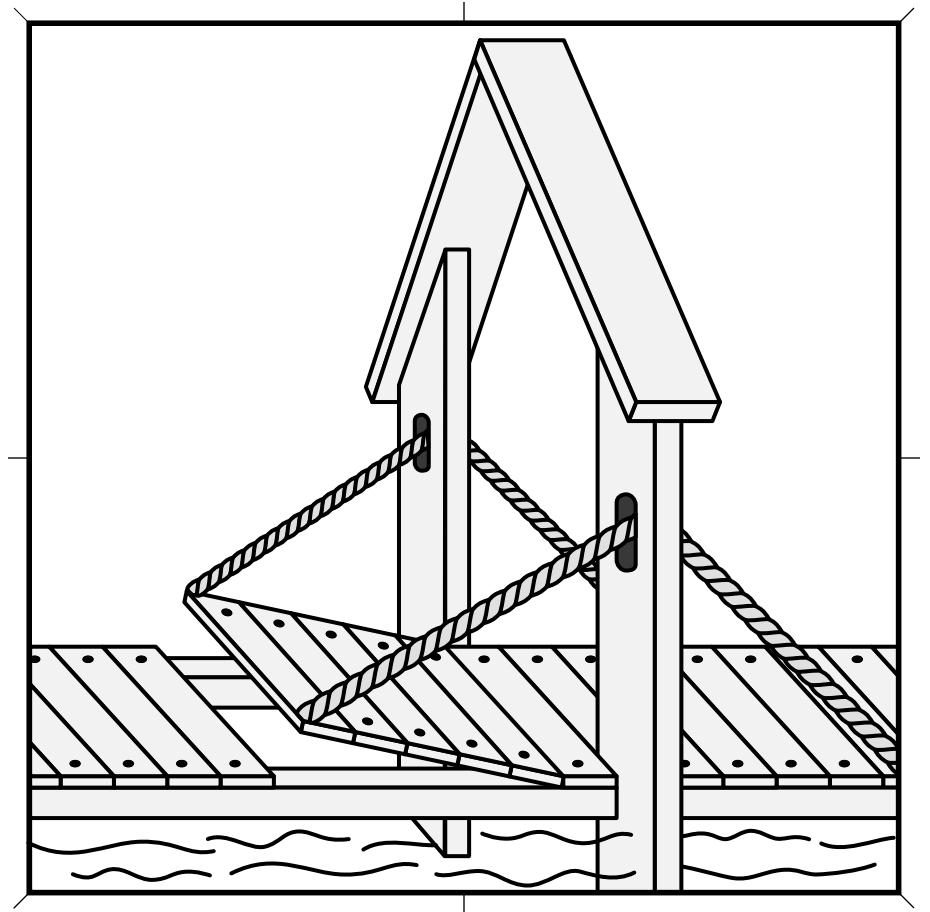
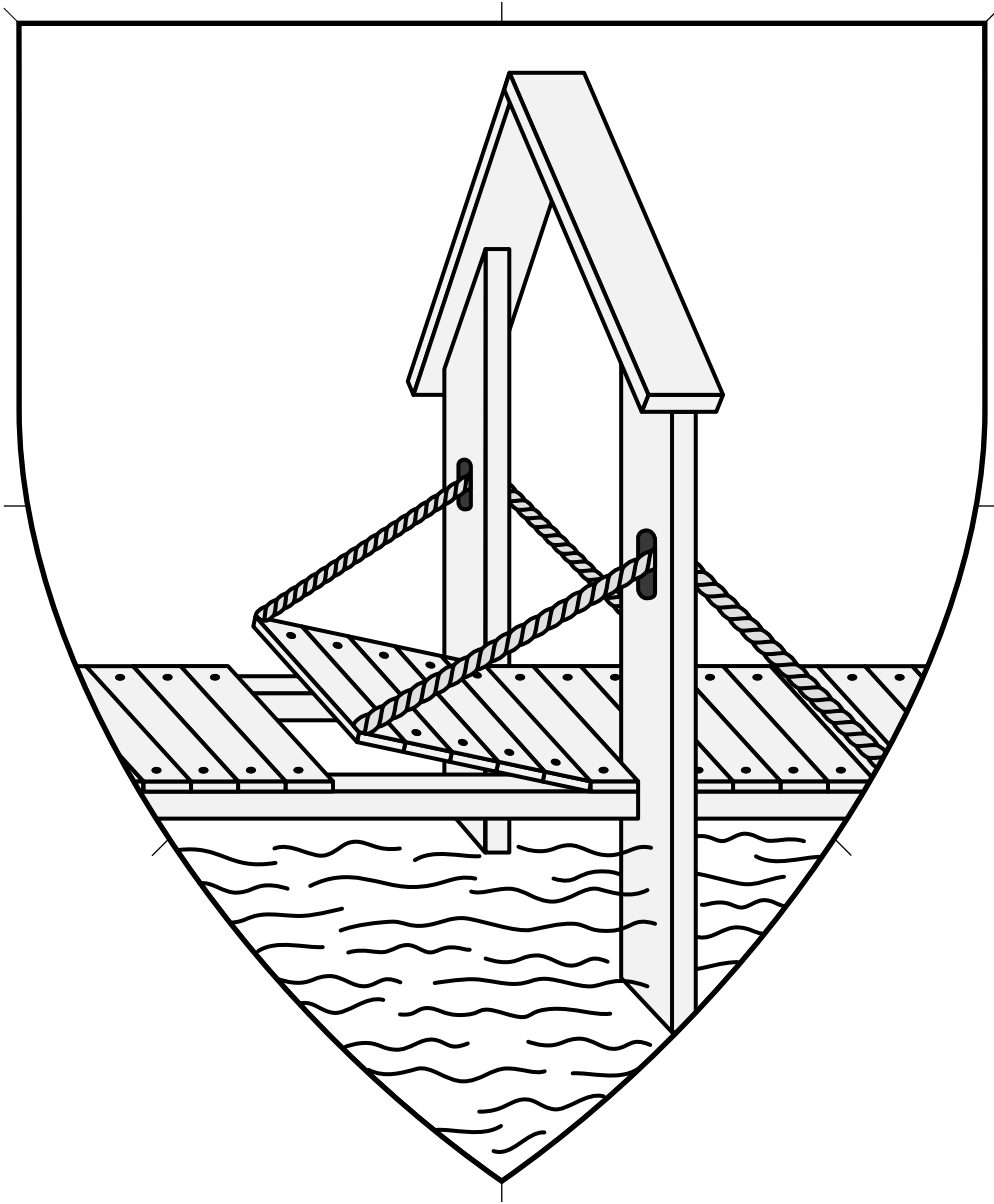

A mobile entrance for a fortified edifice.

Default orientation: seen from above. Proper coloration: brown wood.

Source: Schlesisches Wappenbuch. Artist unknown. (Page 145.)

Drawbridge (2) 17.125

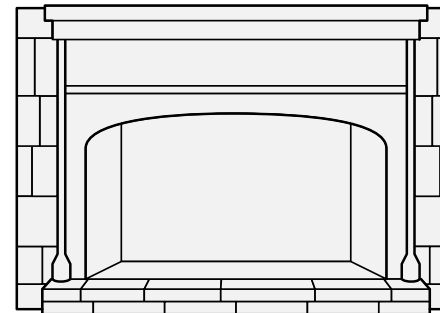
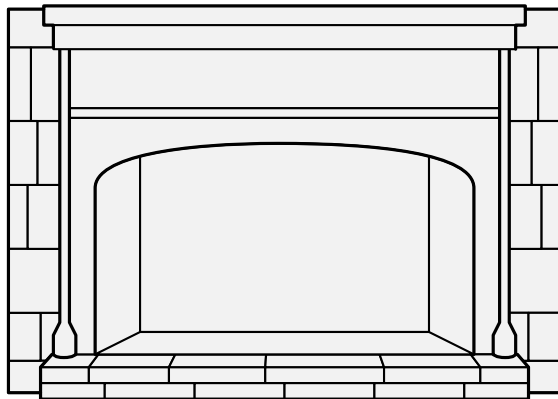
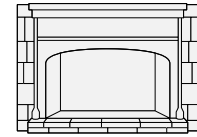
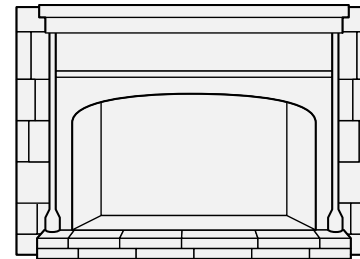
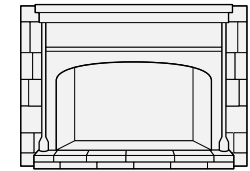
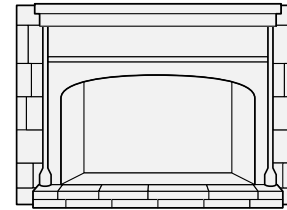
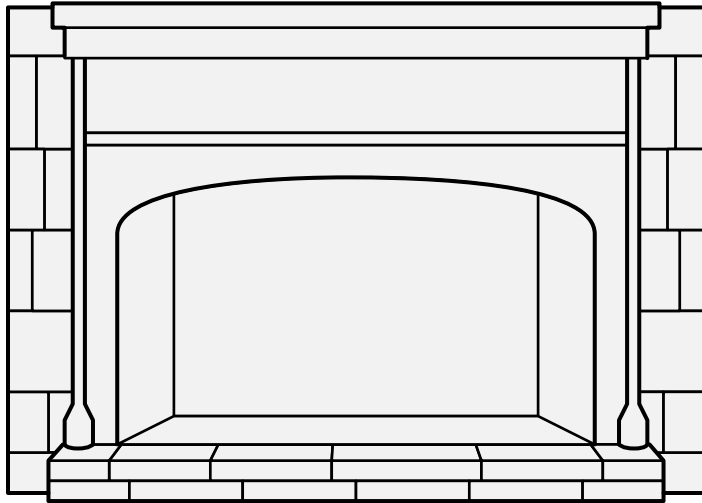

A masonry structure to contain an indoor fire.
Default orientation: upright affronty. No proper coloration.
Adapted from images of the fifteenth-century fireplace at Tattershal Castle.

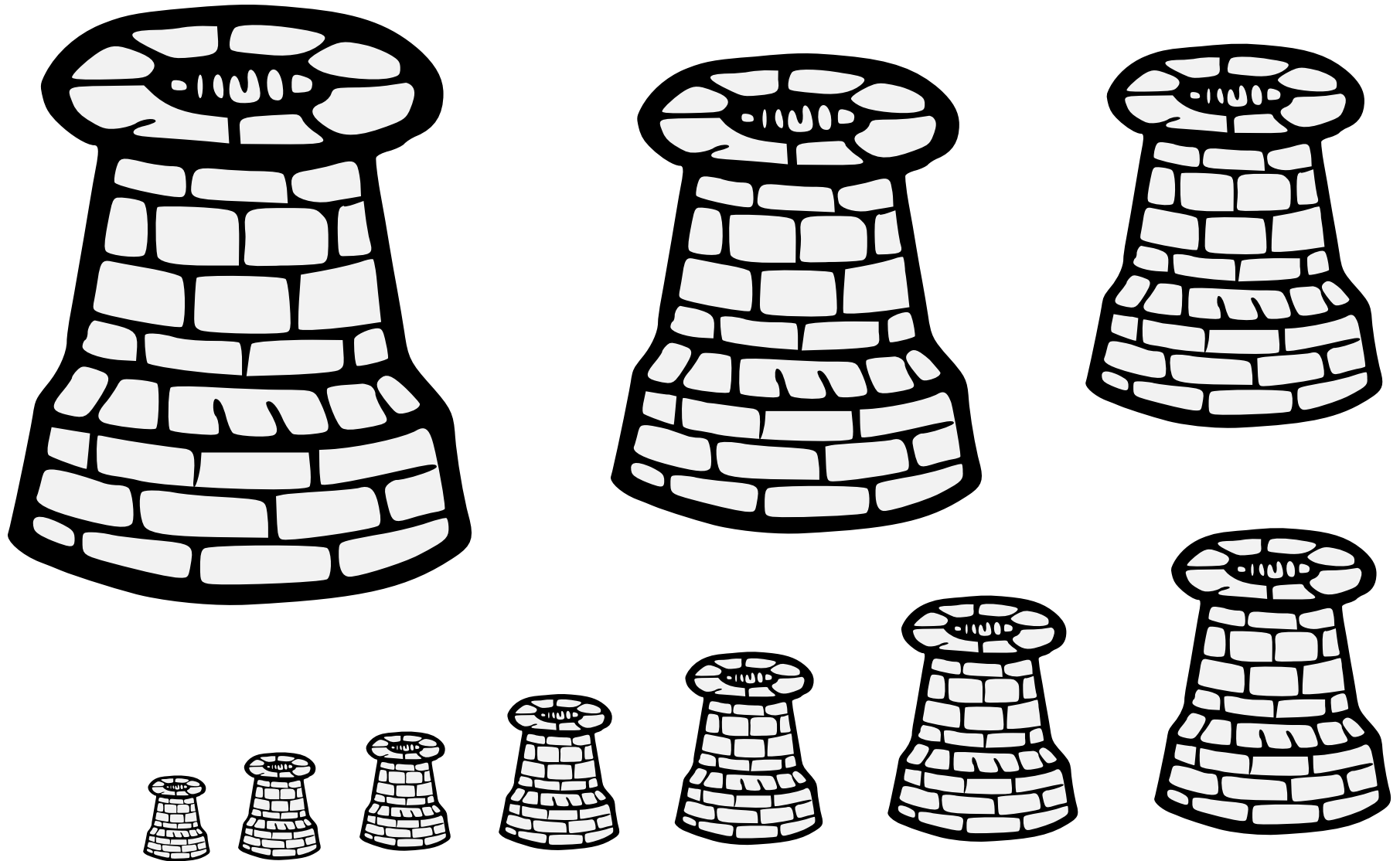

A stone structure dispensing water.

Default orientation: opening to chief.

Proper coloration: gray or argent stone.

Source: The Art of Heraldry. Artist: Unknown.

Fountain, Natural (1) 17.127

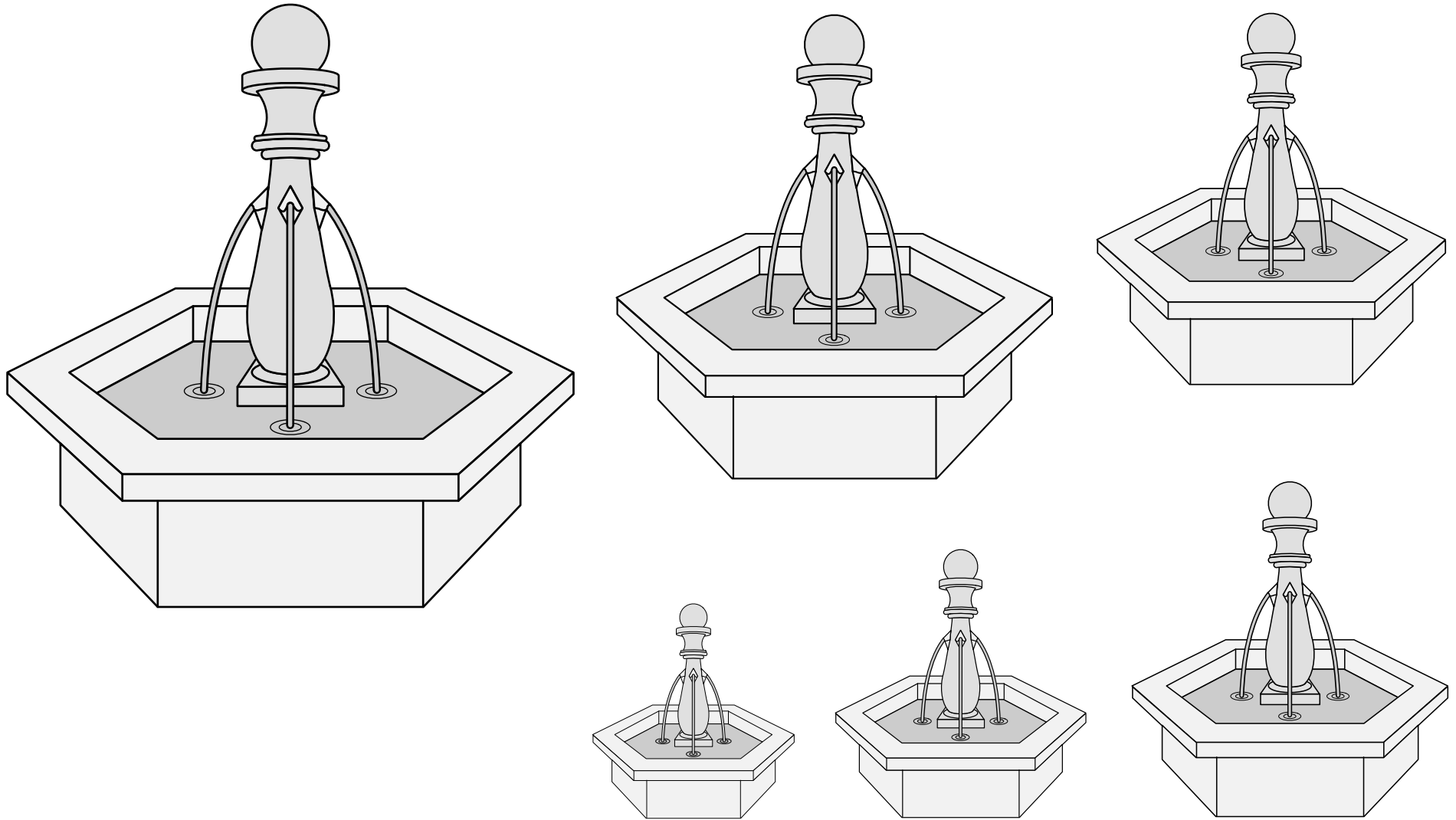

A stone structure dispensing water.

Default orientation: opening to chief.

Proper coloration: gray or argent stone.

Source: Sammelband Mehrerer Wappenbücher.

Artist unknown. (Folio 9v.)

Fountain, Natural (2) 17.128

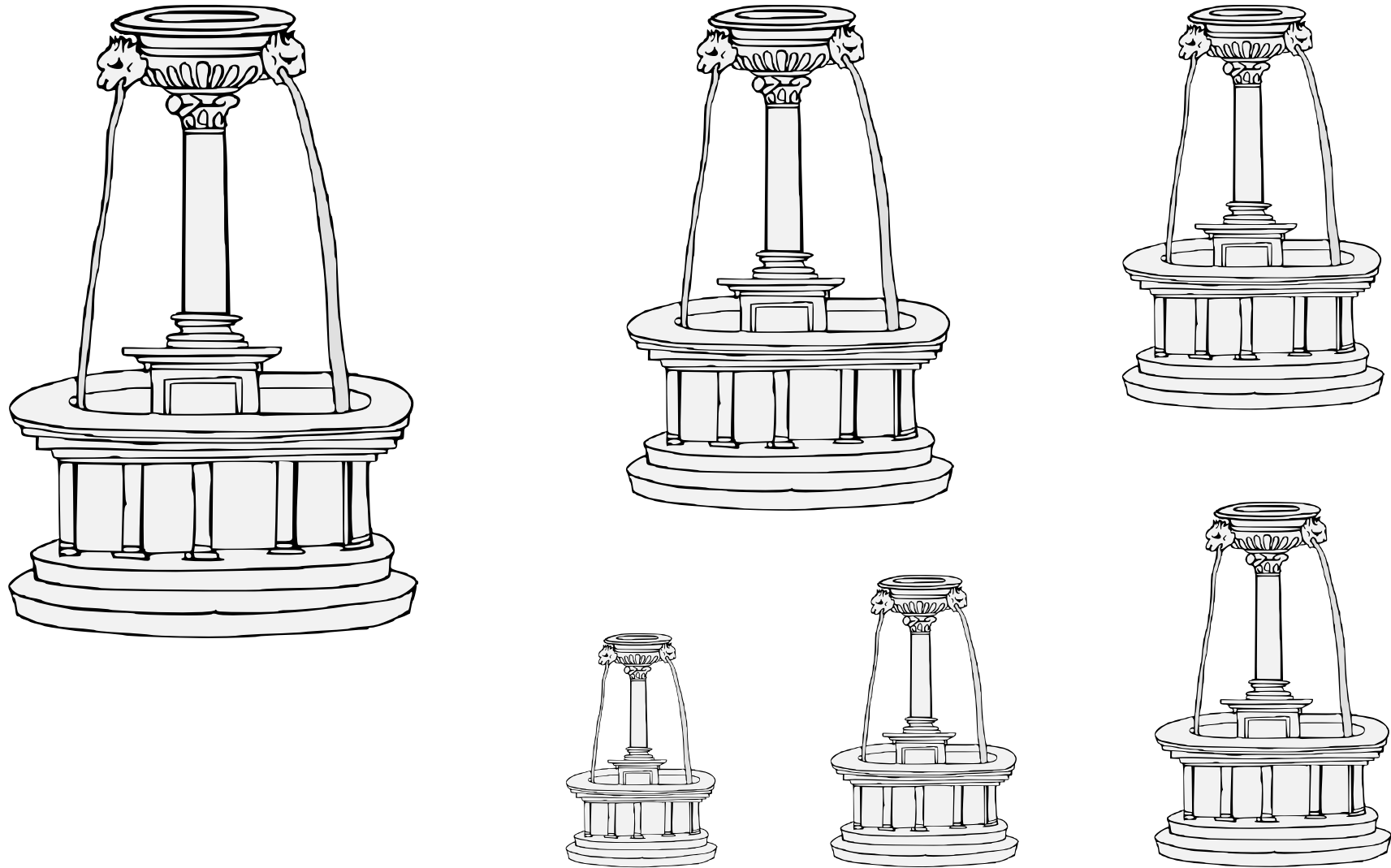

A stone structure dispensing water.

Default orientation: opening to chief.

Proper coloration: gray or argent stone.

Source: Insignia Venetorum Nobilium II. Artist unknown.

(From the arms of Colonizi, folio 110.)

Adapted by Thora Brandsdottir.

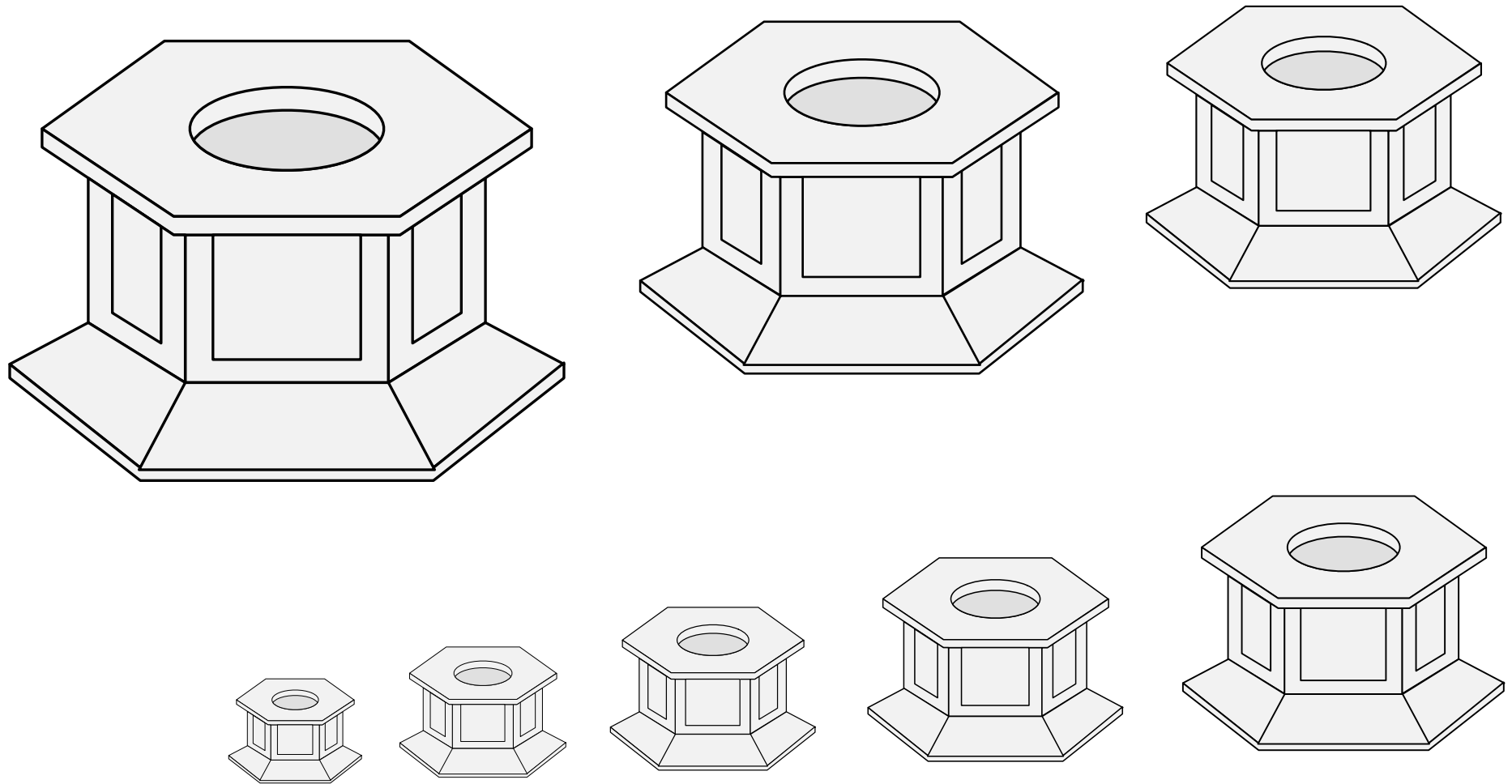

A stone structure dispensing water.

Default orientation: opening to chief. Proper coloration: gray or argent stone.

Source: Stemmario Trivulziano. Artist unknown.

(Page 321, arms of da St. Gallo.)

Adapted by Mathghamhain Ua Ruadháin.

Fountain, Natural (4) 17.130

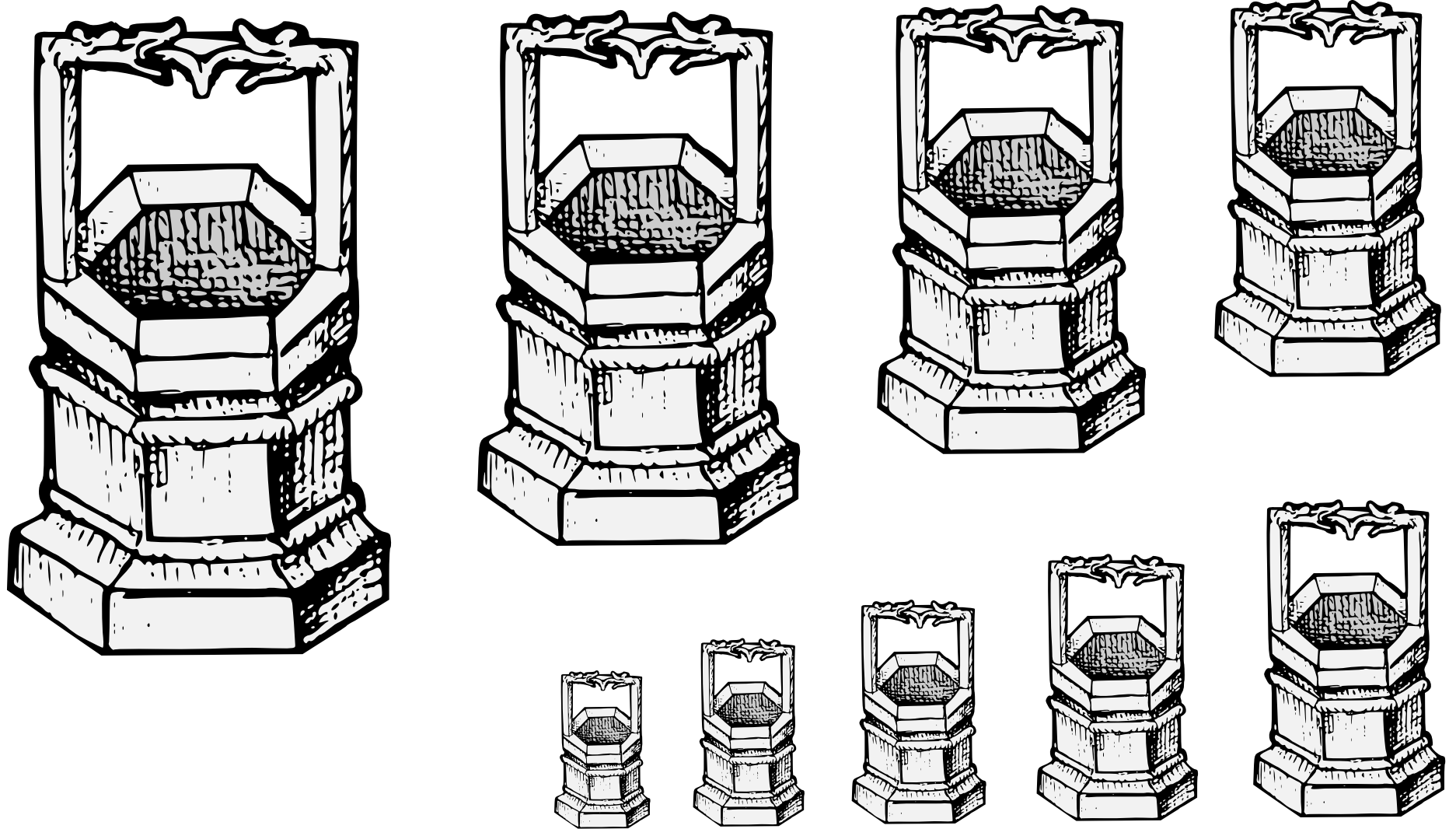

A stone structure dispensing water.

Default orientation: opening to chief. Proper coloration: gray or argent stone.

Source: Armorial Catalan. Artist unknown.
(Folio 31r, arms of Pon.)

Fountain, Natural (5) 17.131

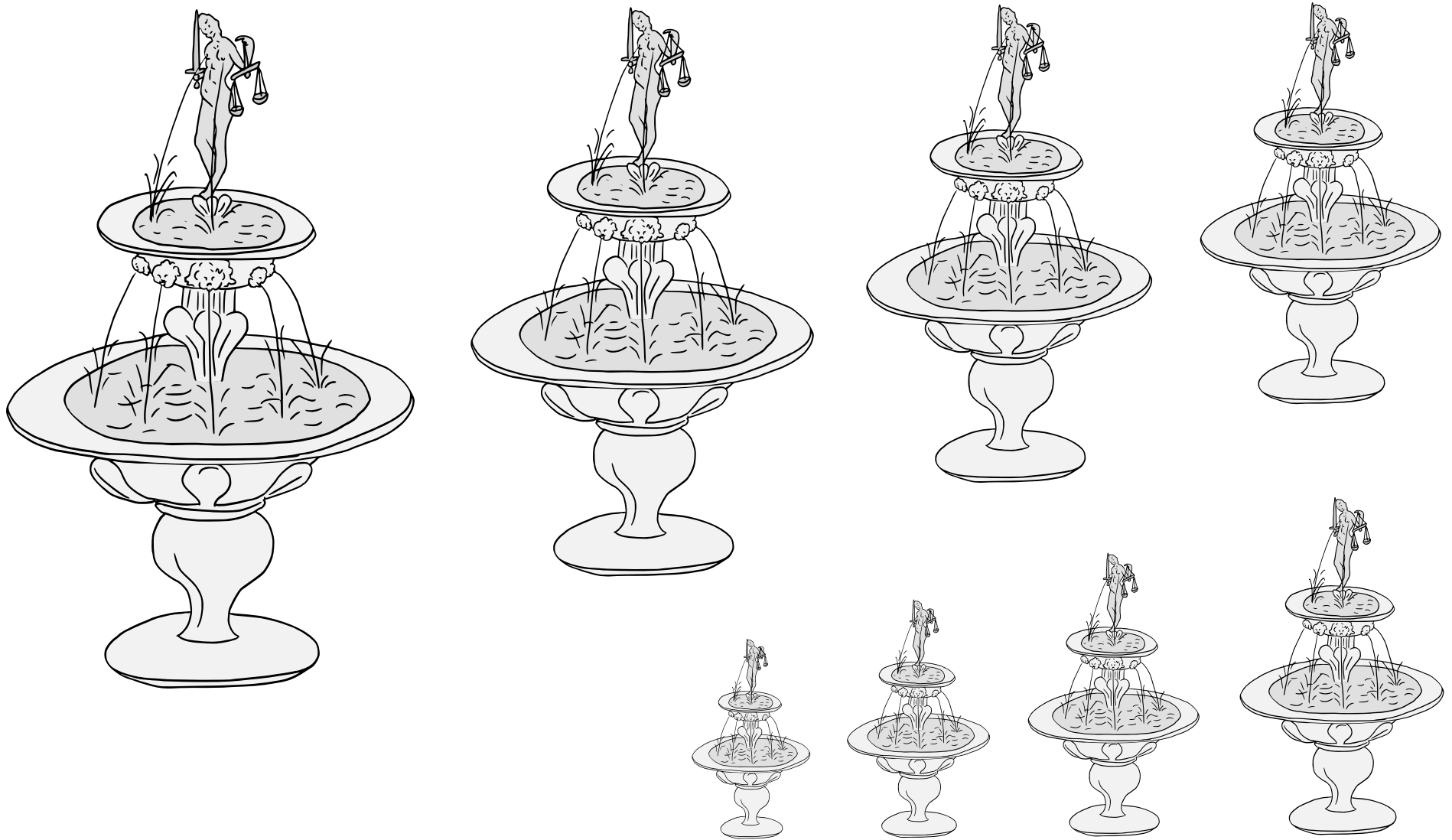

A stone structure dispensing water.

Default orientation: opening to chief. Proper coloration: gray or argent stone.

Source: Eberhardt Kößler vnnnd seine Nachkummen. Artist unknown.
(Folio 9v.) Adapted by Malys Makneile.

Fountain, Natural (6) 17.132

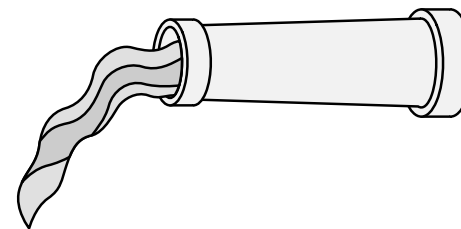
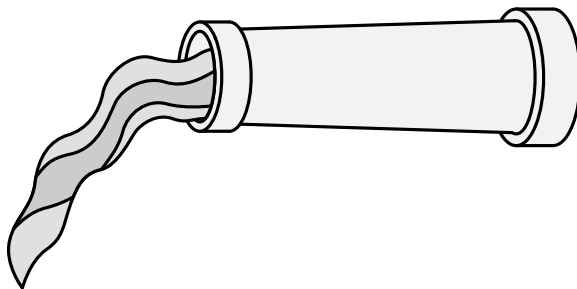
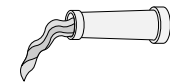
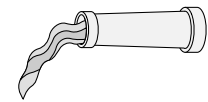
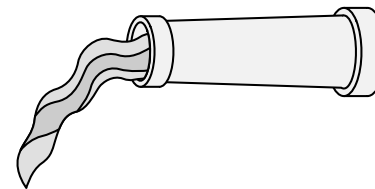
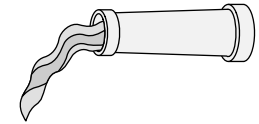
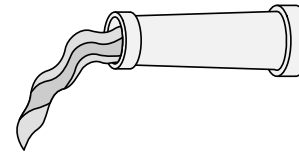
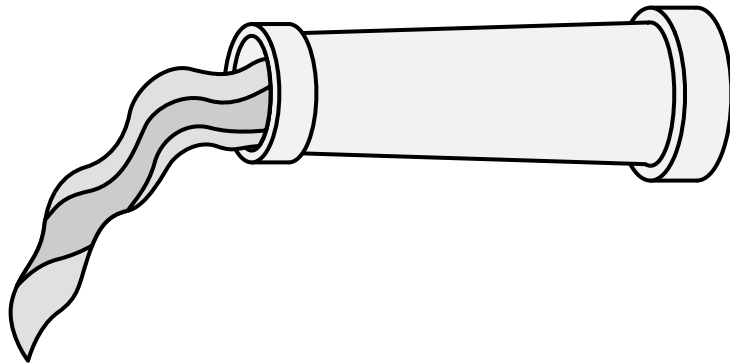

An open-ended pipe with water flowing from it.

Default orientation: fesswise, flowing to dexter. No proper coloration.

Source: Livro de Armas de Portugal e Outras Curiosidades.
(Arms of Botado, folio 148.) Artist unknown.

Fountain Spout 17.133

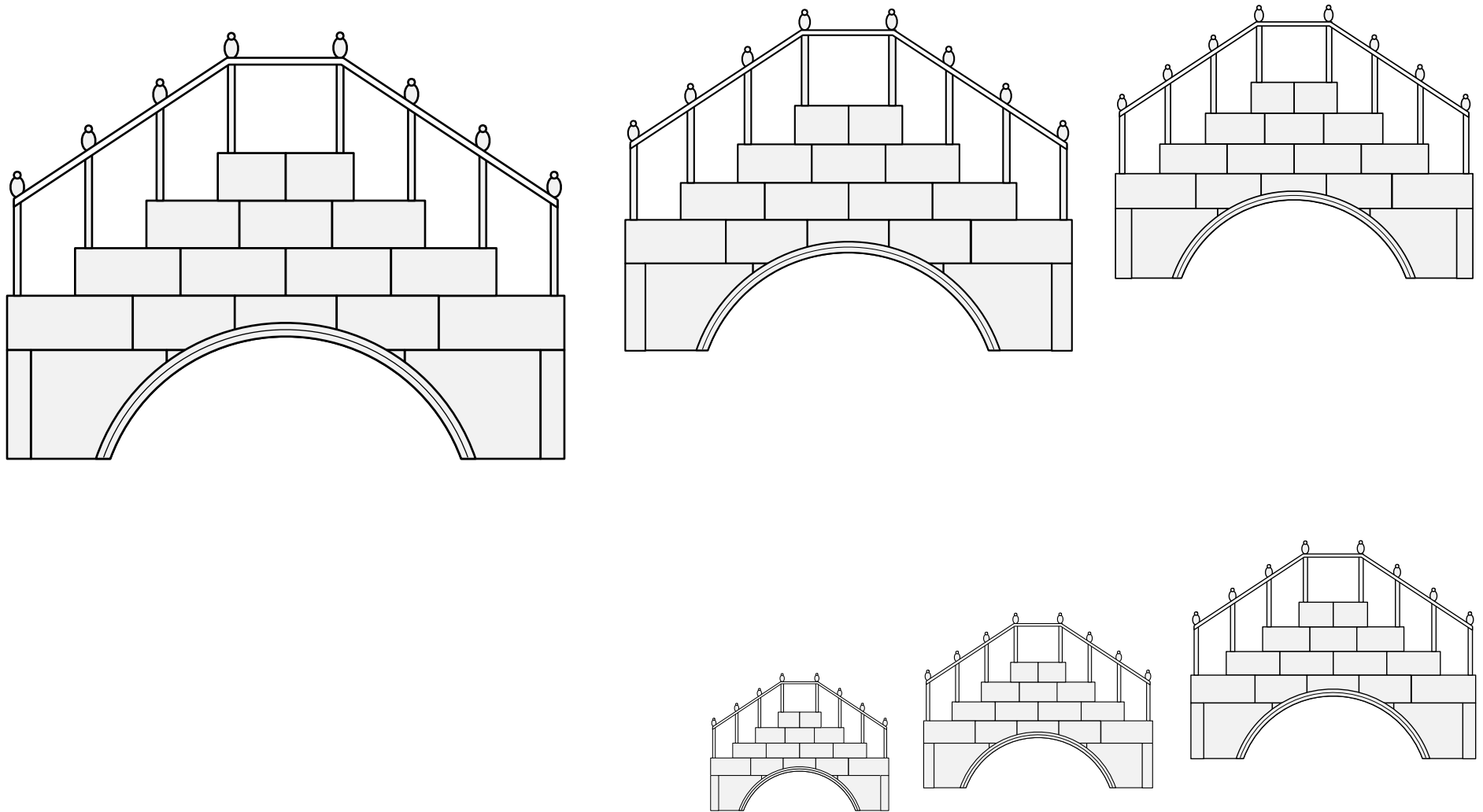

A structure for traveling over a river.

Default orientation: fesswise. No proper coloration.

Source: Insignia Venetorum Nobilium III. Artist unknown.
(From the arms of Ponte, folio 81). Adapted by Mathghamhain Ua Ruadháin.

Footbridge 17.134

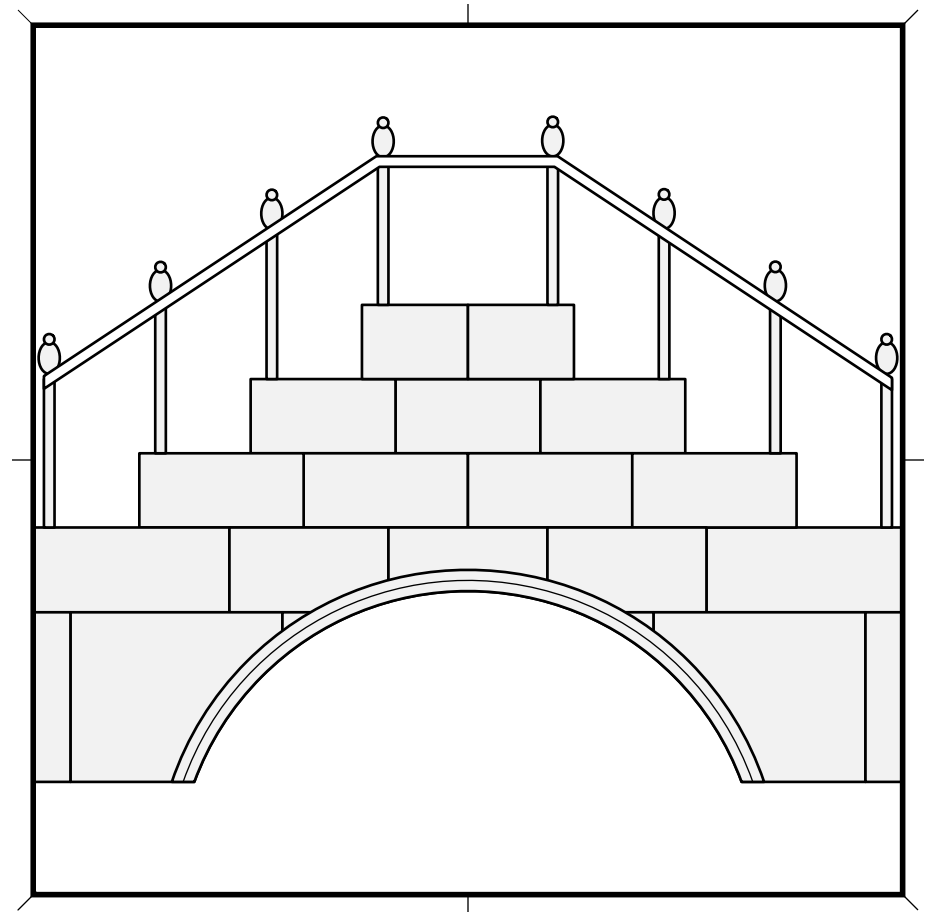
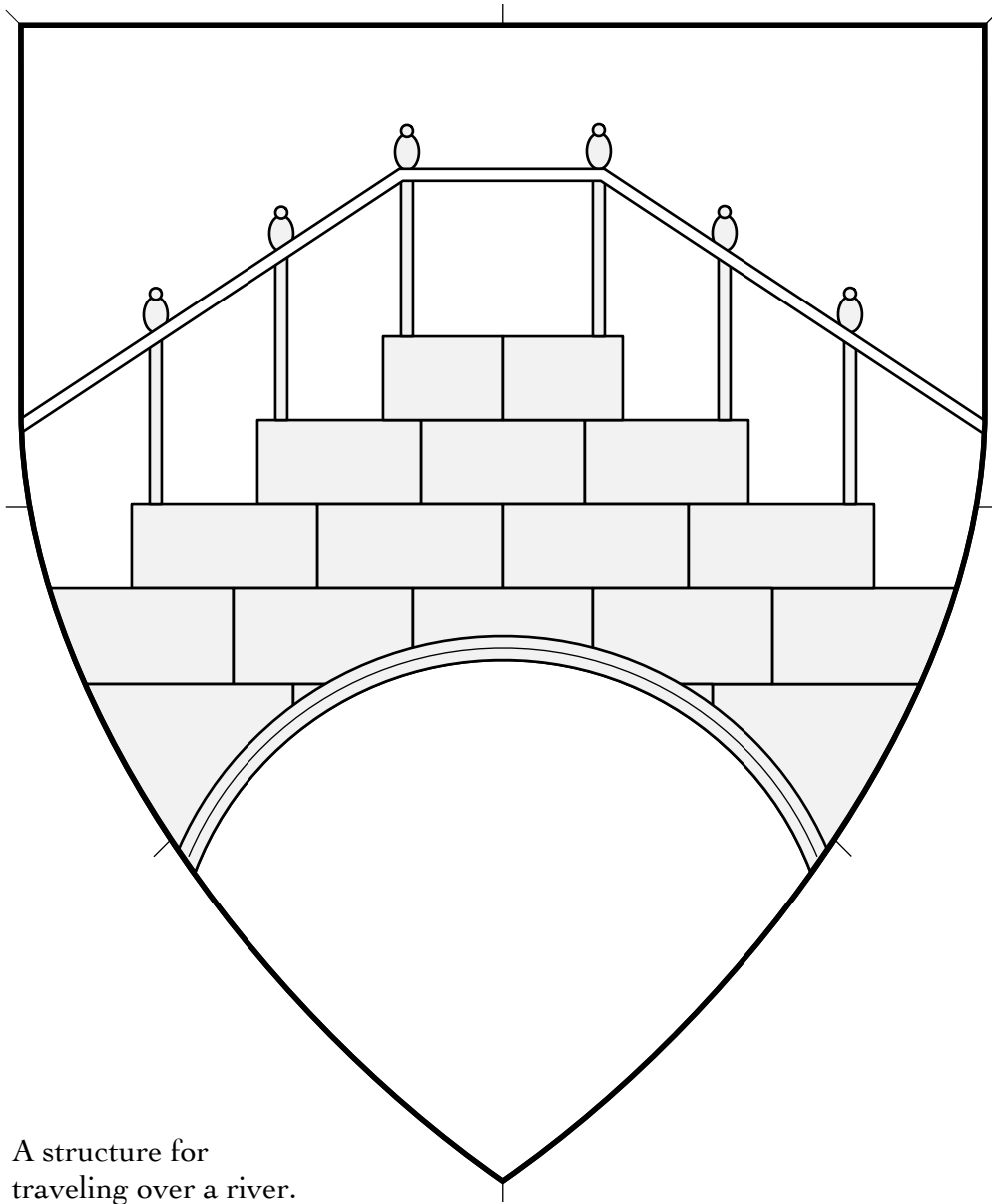

A structure for
traveling over a river.

Default orientation: fesswise. No proper coloration.

Source: Insignia Venetorum Nobilium III. Artist unknown.
(From the arms of Ponte, folio 81).

Adapted by Mathghamhain Ua Ruadháin.

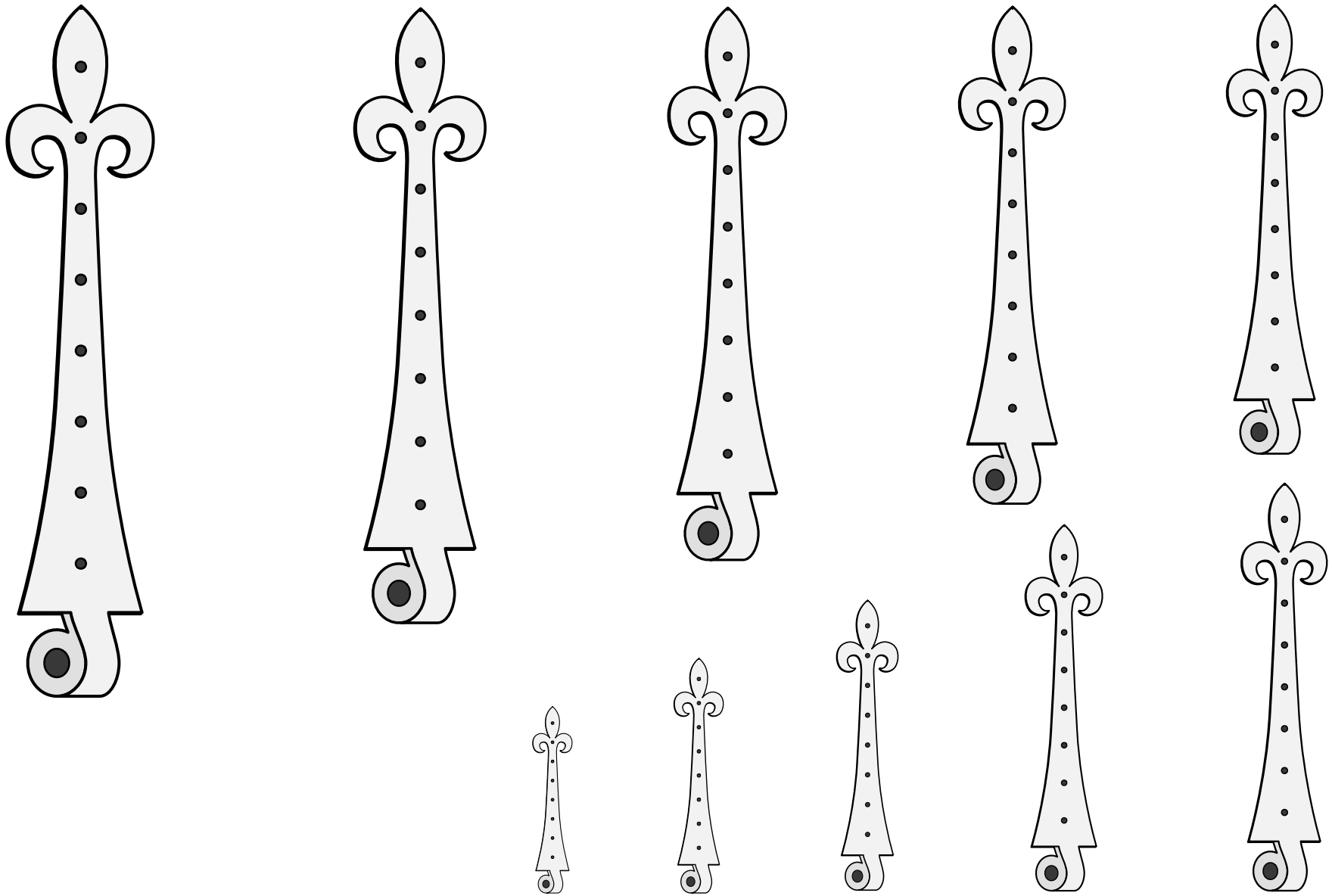

A metal strap with an attached loop that allows doors to pivot.

No default orientation. No proper coloration.

Source: Schlesisches Wappenbuch. Artist unknown. (Folio 19r.)

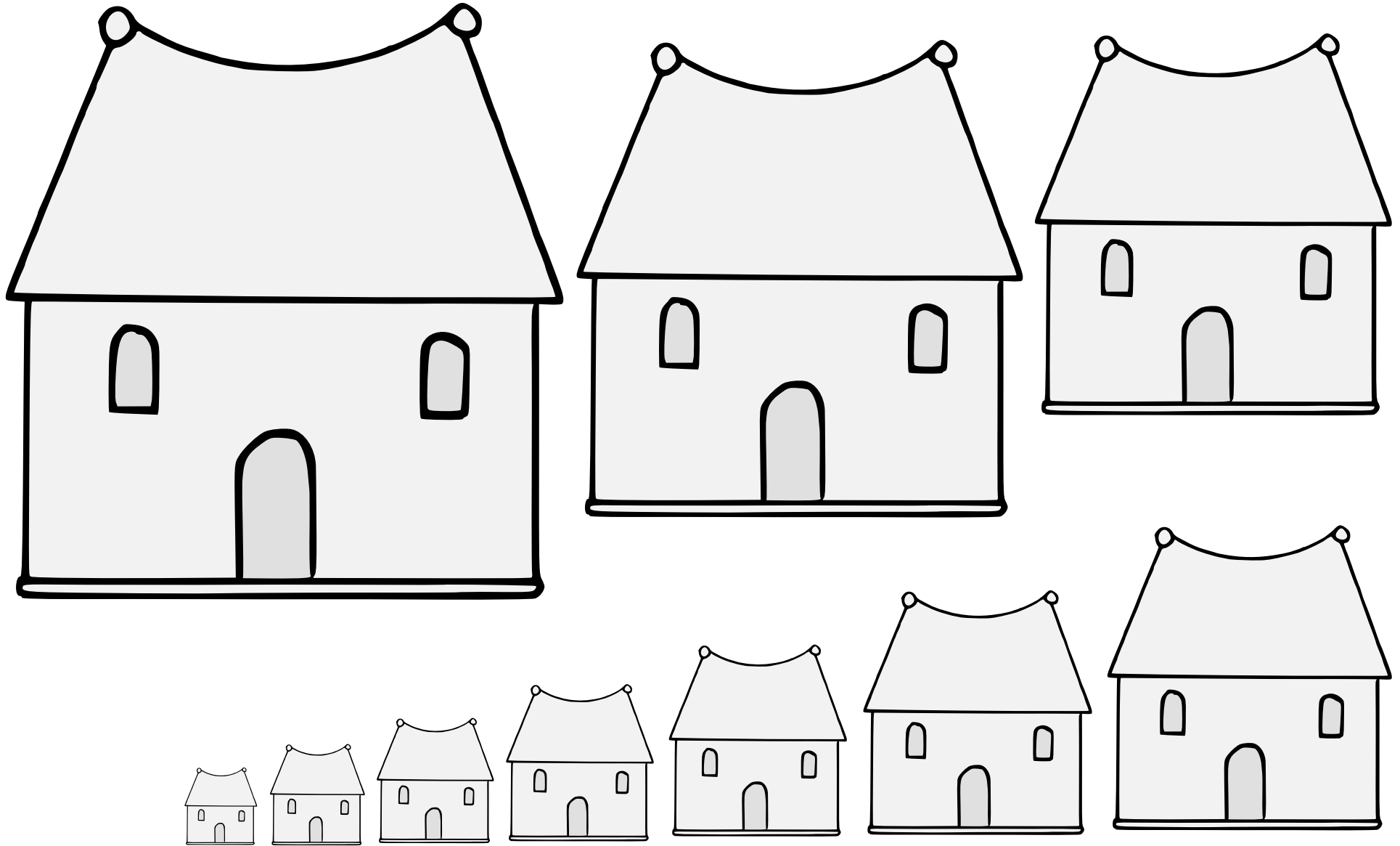

A small residential building.

Default orientation: upright. No proper coloration.

Source: Pennsic Traceable Art. Artist unknown.

House (1) 17.137

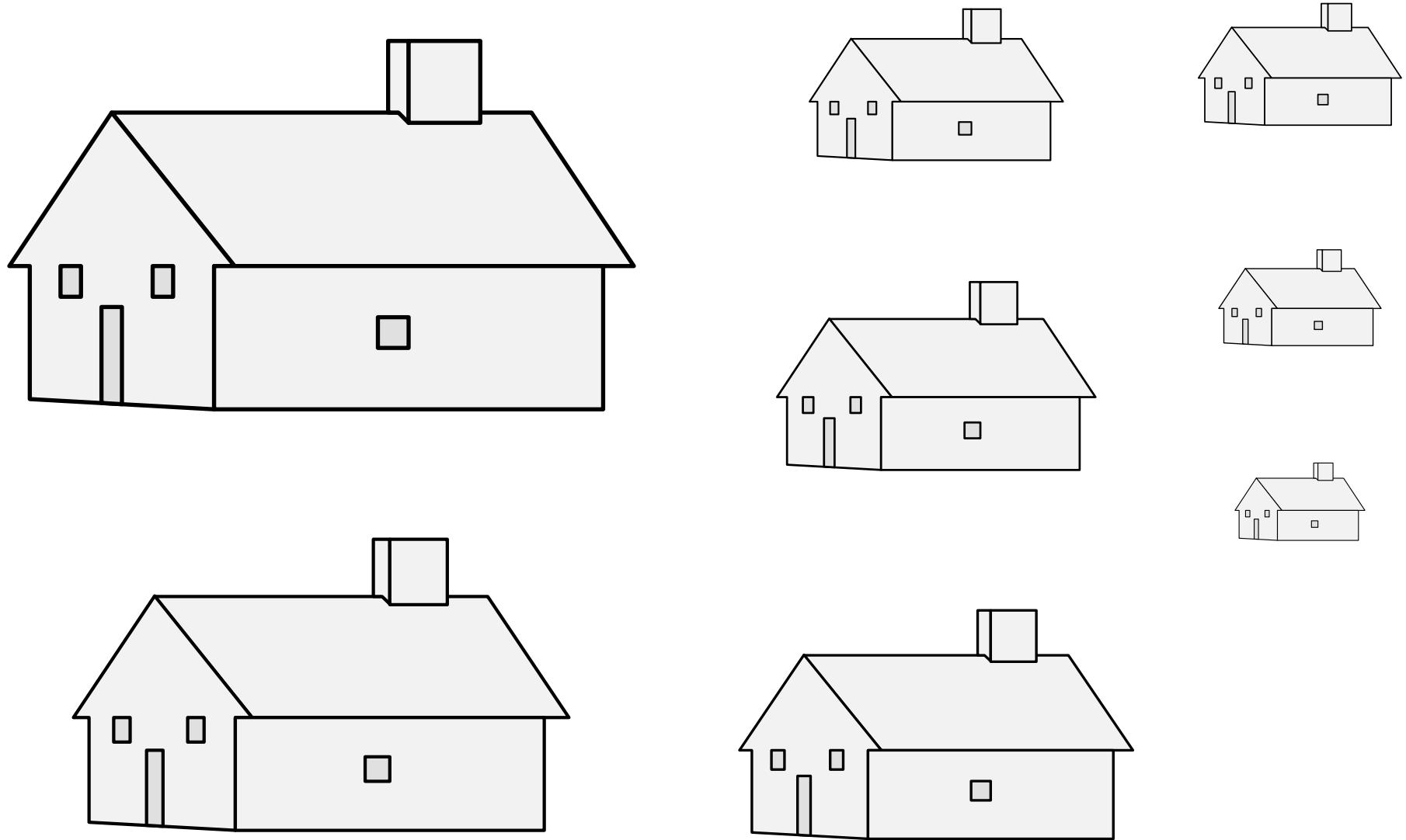

A small residential building.

Default orientation: upright. No proper coloration.

Source: Stemmario Trivulziano. Artist: Gian Antonio da Tradate. (Arms of de Treca, p 352.)

House (2) 17.138



A small residential building.

Default orientation: upright. No proper coloration.

Source: Le Blason Des Armoiries. Artist: Jérôme de Bara. (Page 59.)

House (3) 17.139

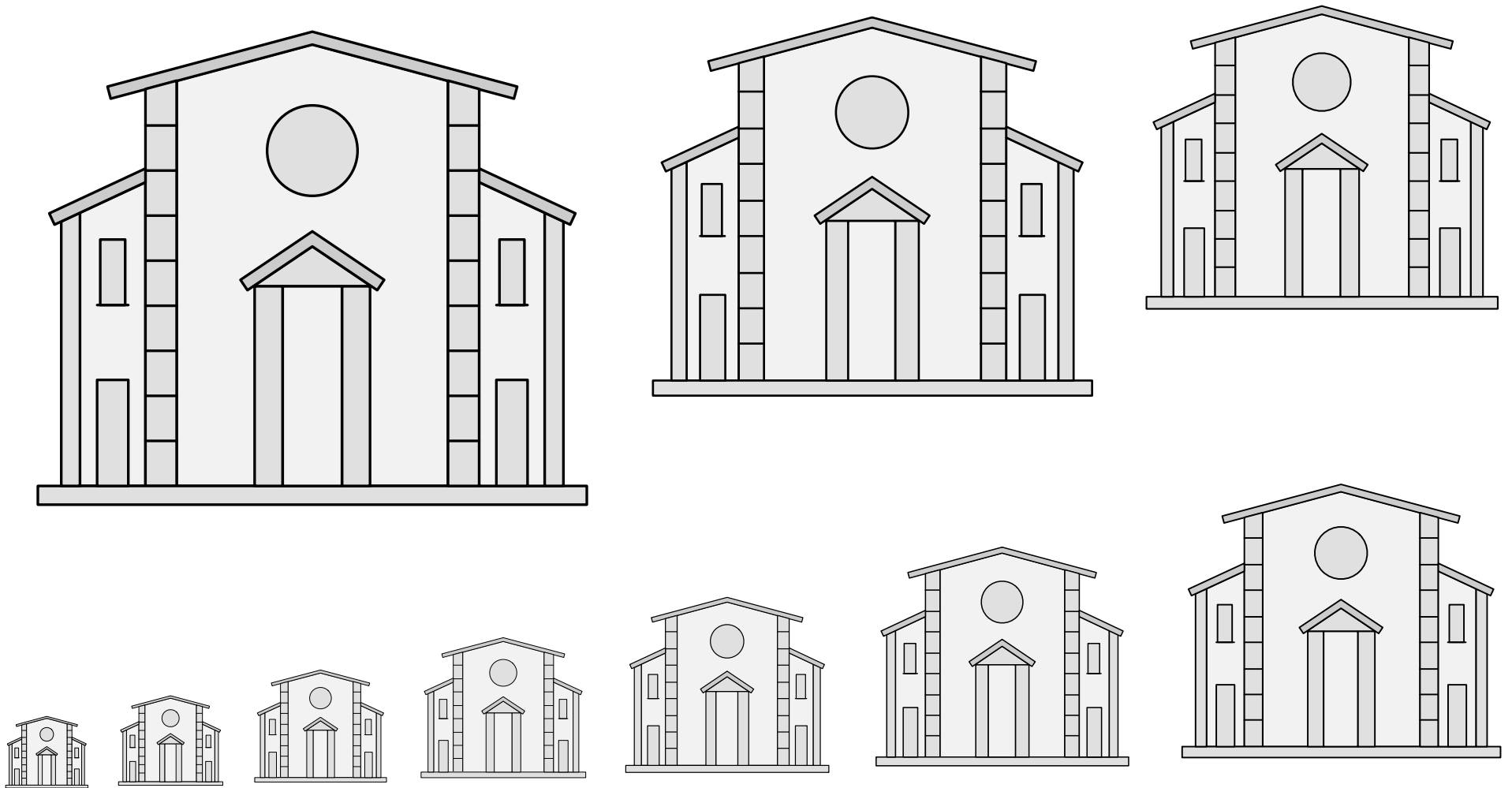

A small residential building.

Default orientation: upright. No proper coloration.

Source: Biblioteca Nazionale Centrale di Firenze, Cappugi. 200.
Artist unknown. Adapted by Mathghamhain Ua Ruadháin.

House (4) 17.140

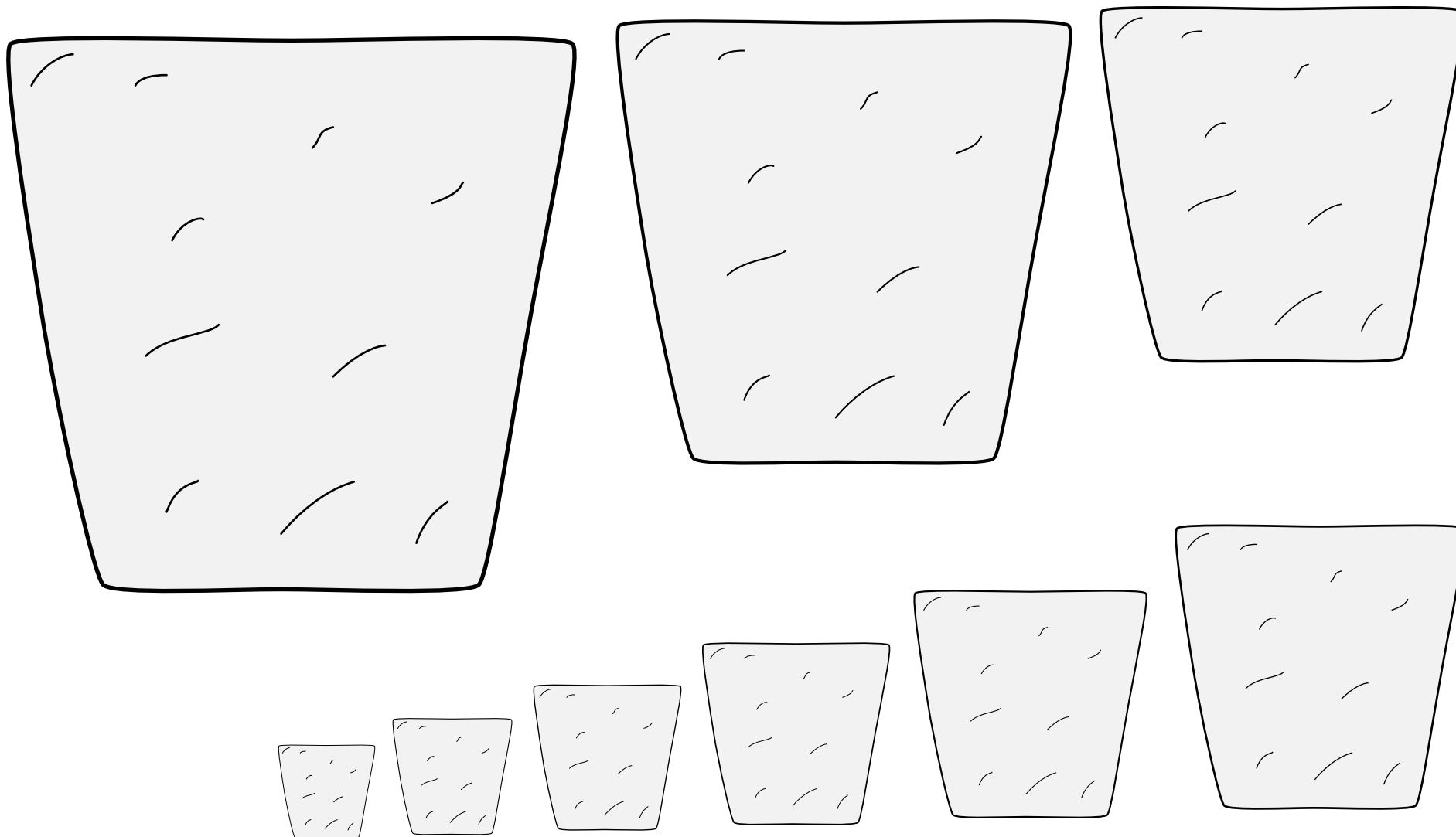

A tapered stone used at the center of an arch.
Default orientation: wide edge to chief. Proper coloration: grey stone.

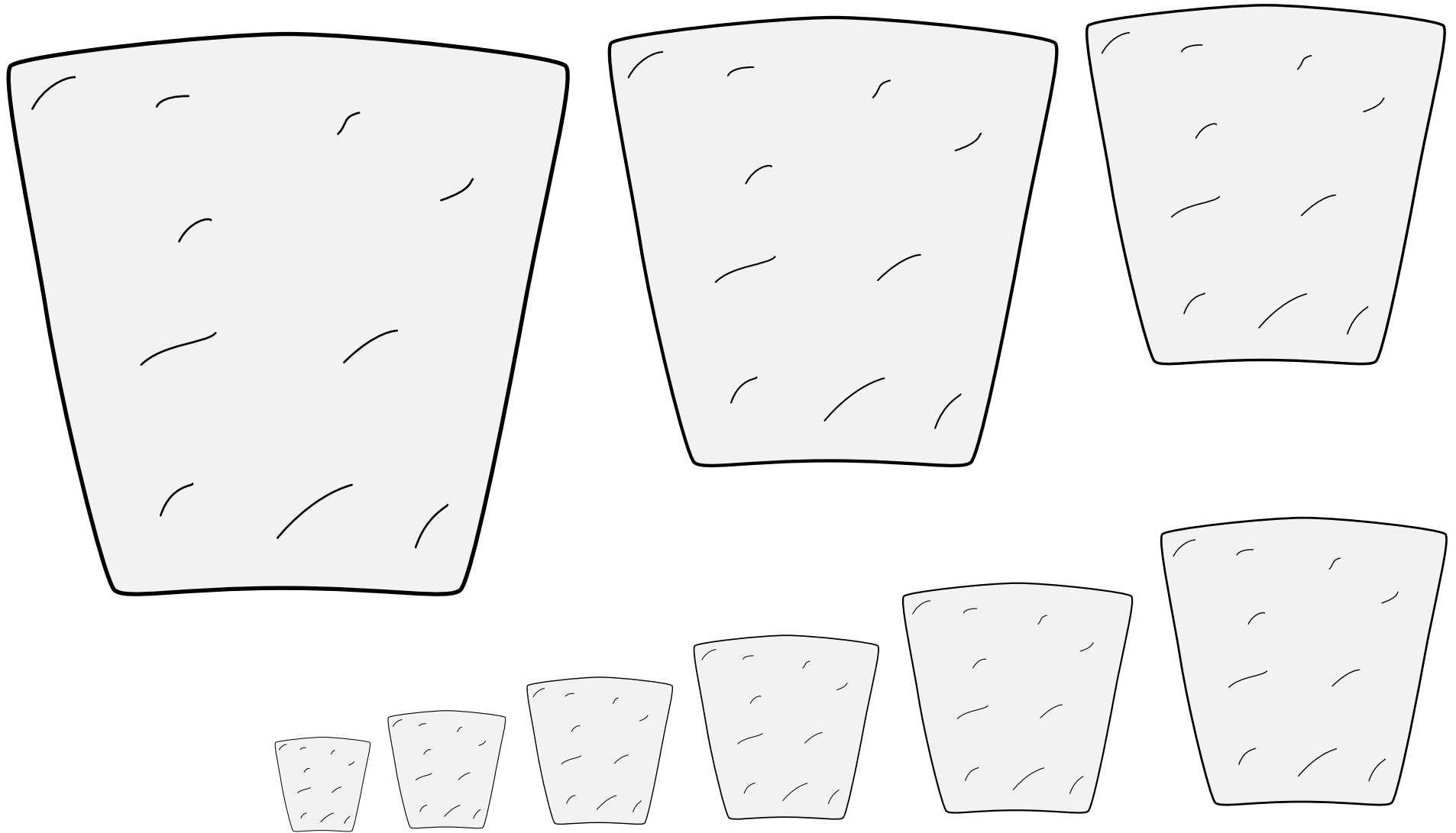

A tapered stone used at the center of an arch.
Default orientation: wide edge to chief. Proper coloration: grey stone.

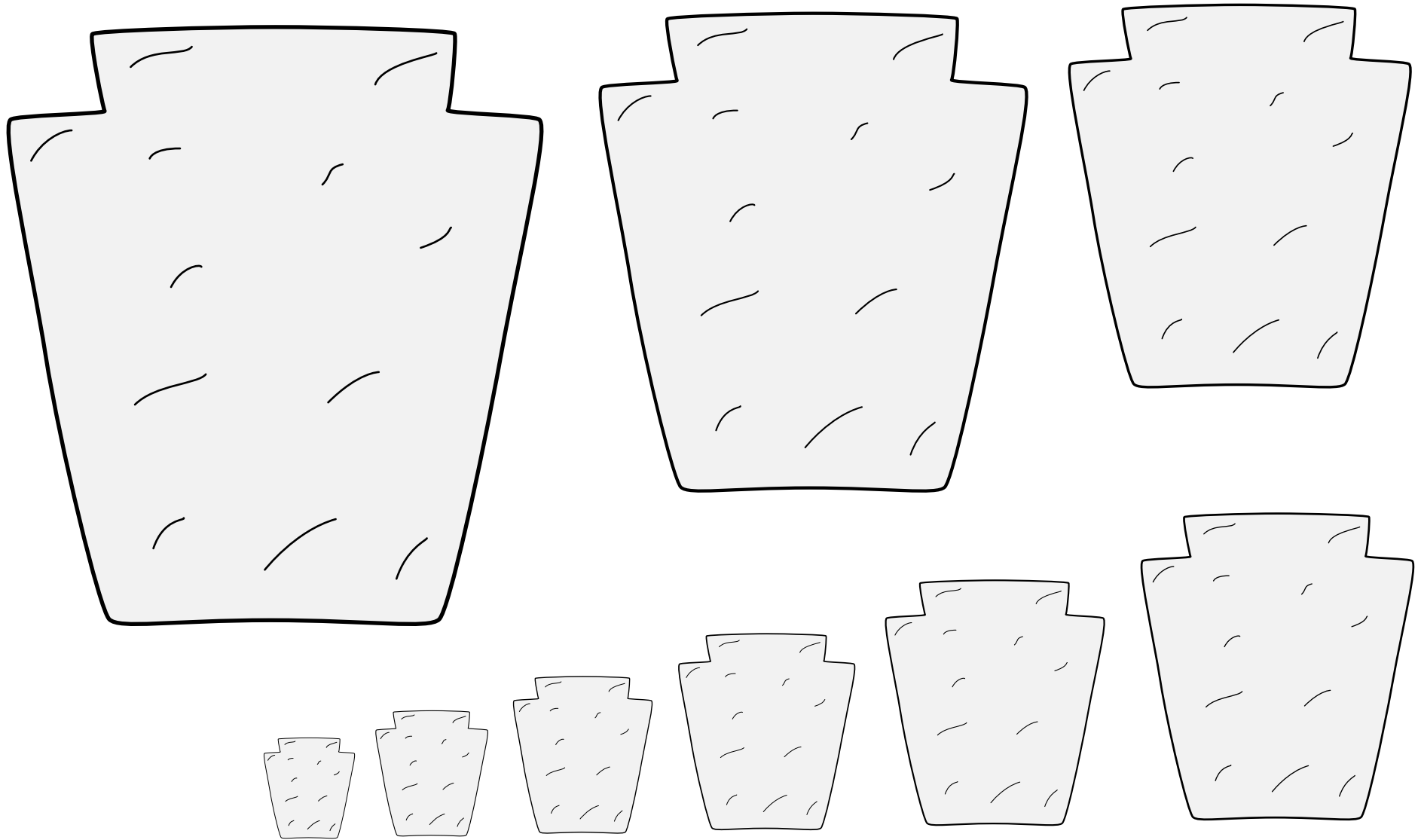

A tapered stone used at the center of an arch.

Default orientation: wide edge to chief. Proper coloration: grey stone.

This version with notched upper corners is no longer registrable following the December 2022 finding that they are a post-period stylization..

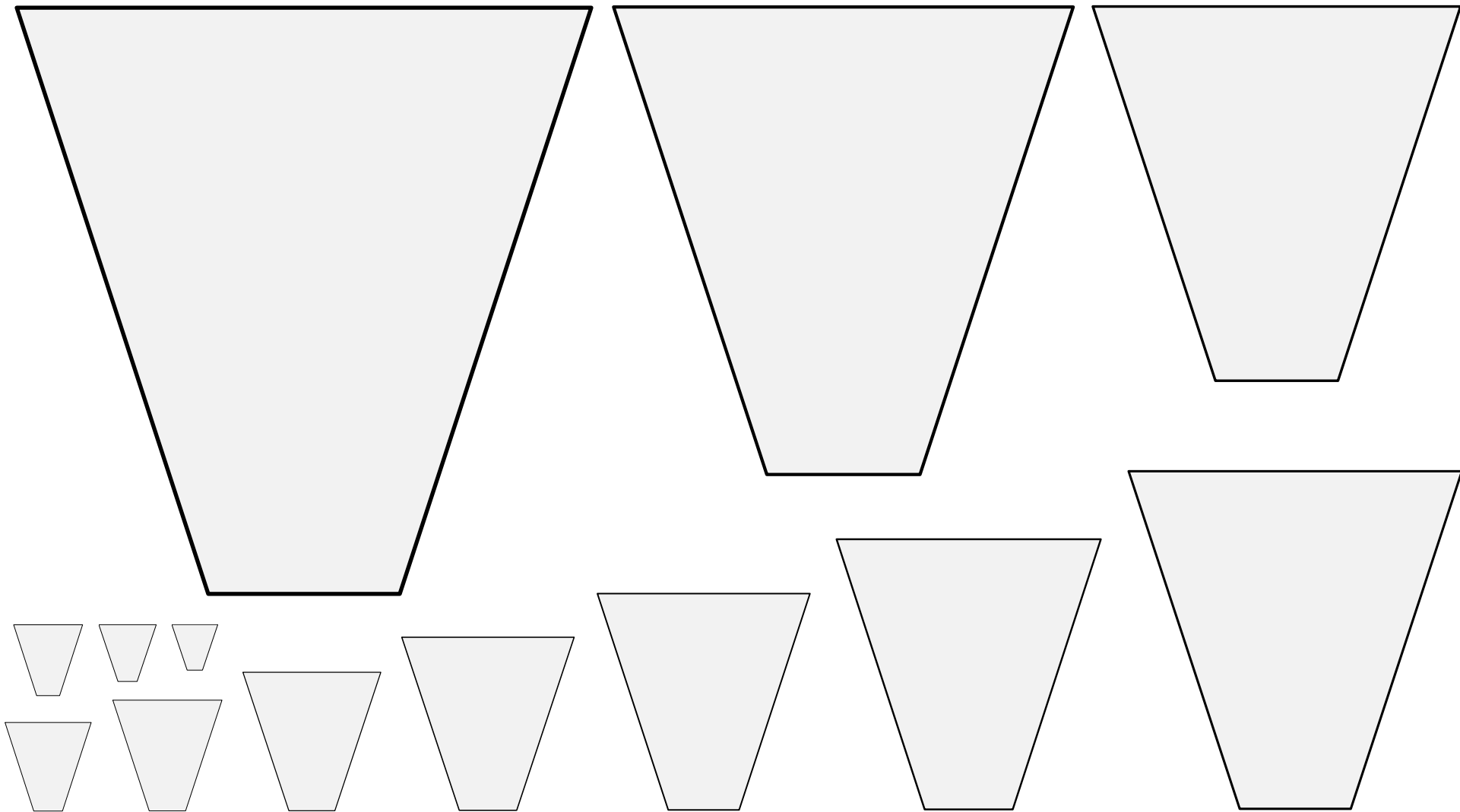

A tapered stone used at the center of an arch.

Default orientation: wide edge to chief. Proper coloration: grey stone.

Source: Armas de los Condes. Artist unknown. (Folio 114.)

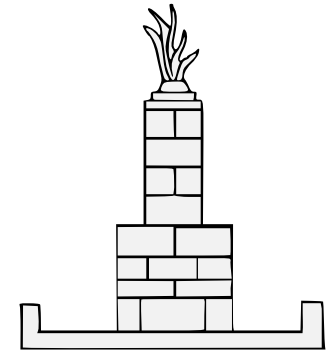
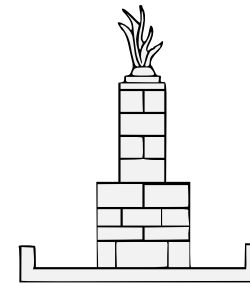
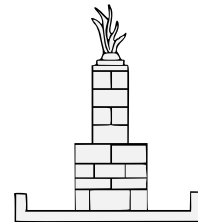
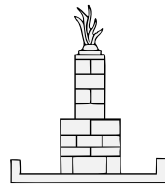
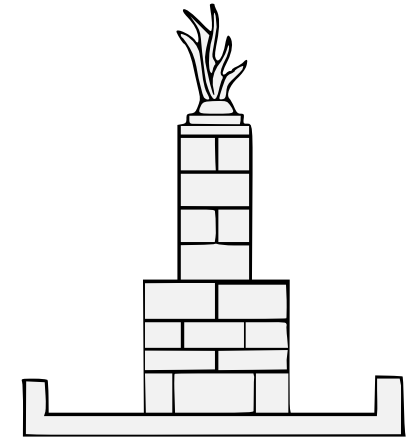
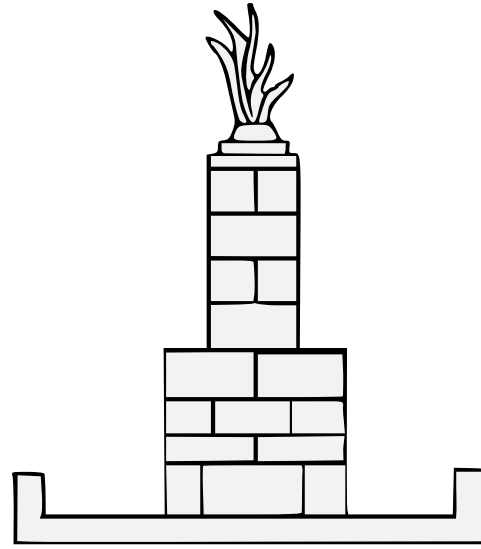
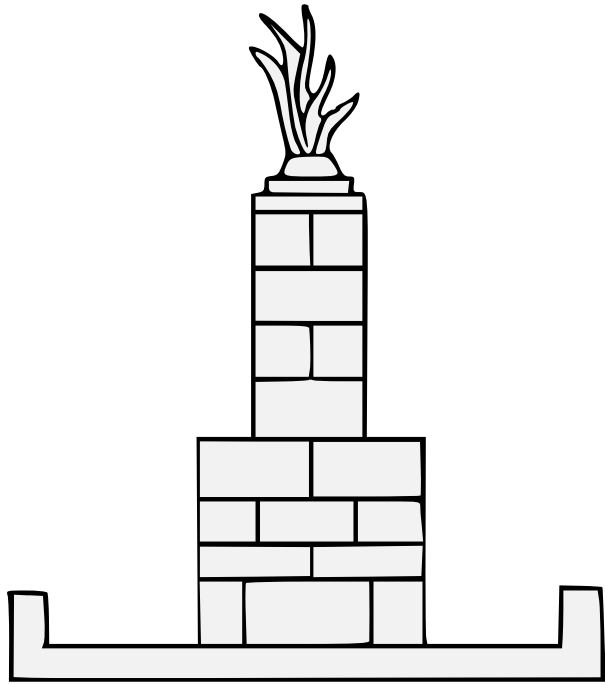

A signal tower used to guide ships into a harbor.
Default orientation: upright. No proper coloration.
Source: Pennsic Traceable Art. Artist unknown.

Lighthouse (1) 17.145

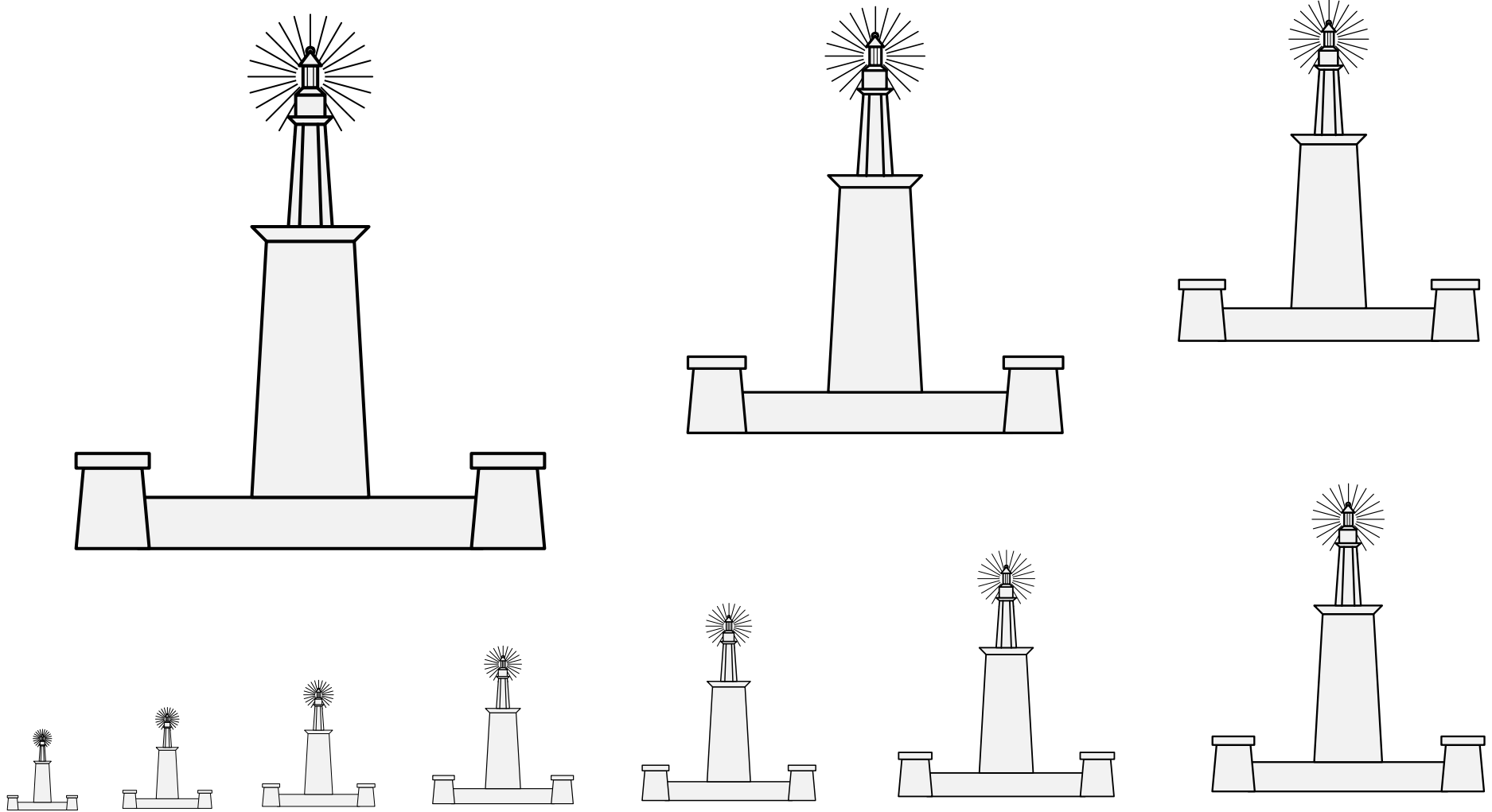

A signal tower used to guide ships into a harbor.
Default orientation: upright. No proper coloration.
Adapted from images of the lighthouse at Alexandria.

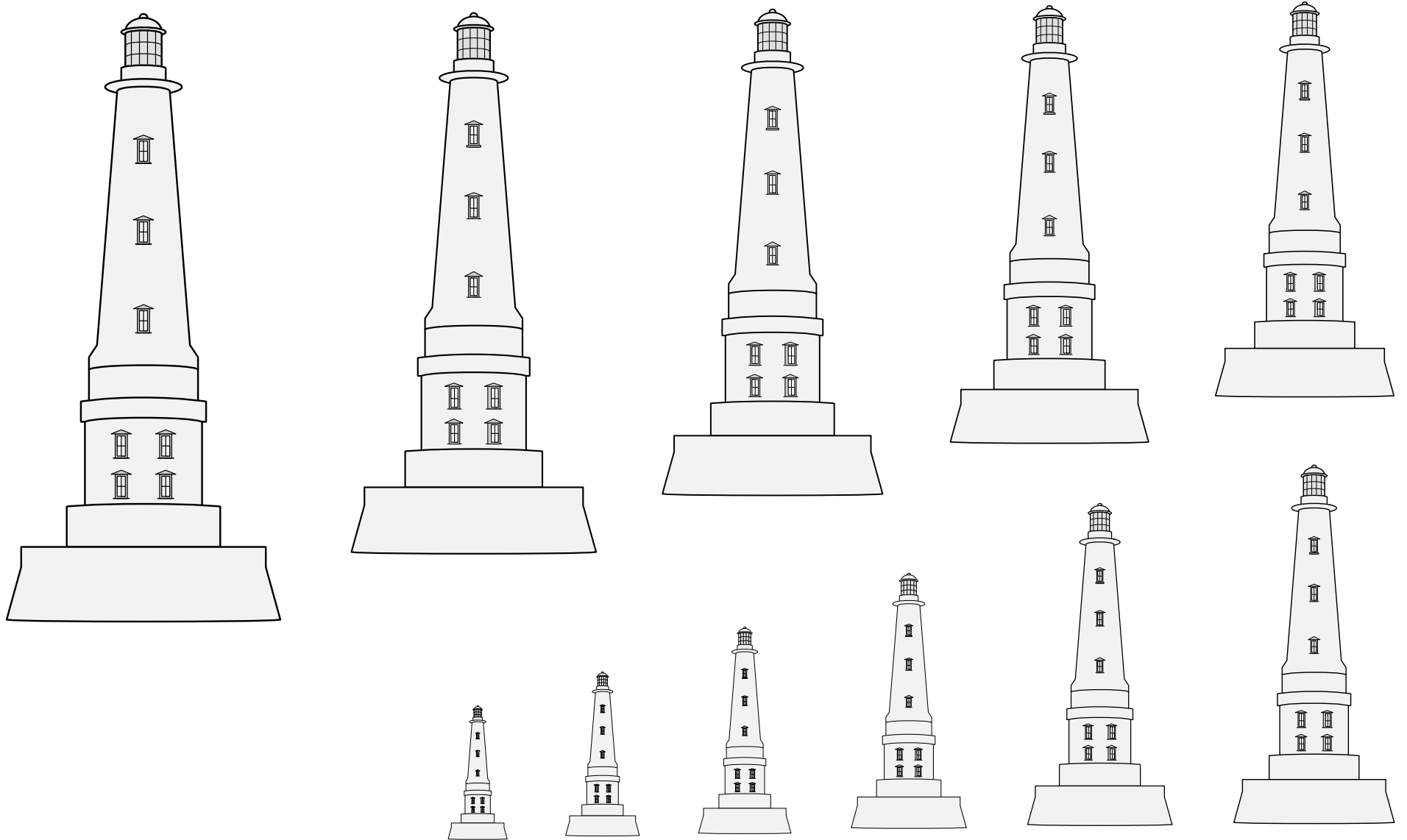

A signal tower used to guide ships into a harbor.
Default orientation: upright. No proper coloration.
Adapted from images of the Cordouan lighthouse, constructed 1584–1611.

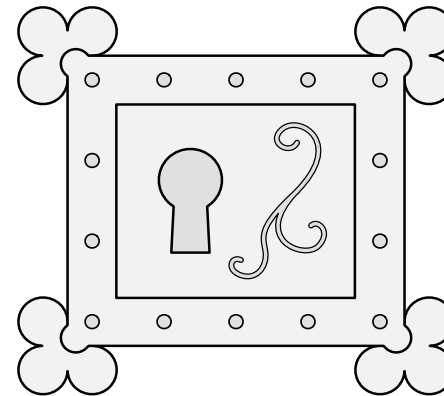
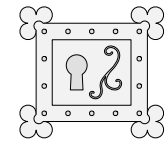
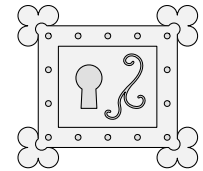
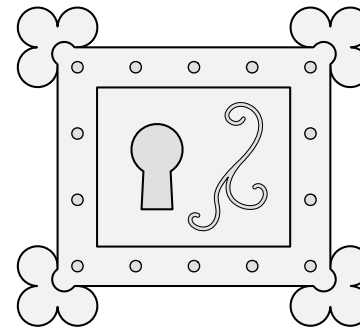
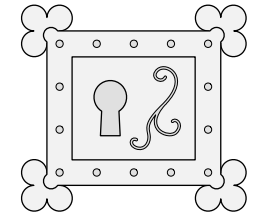
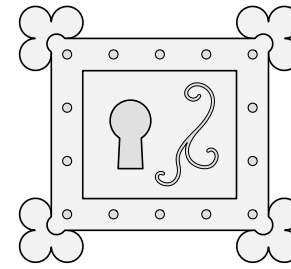
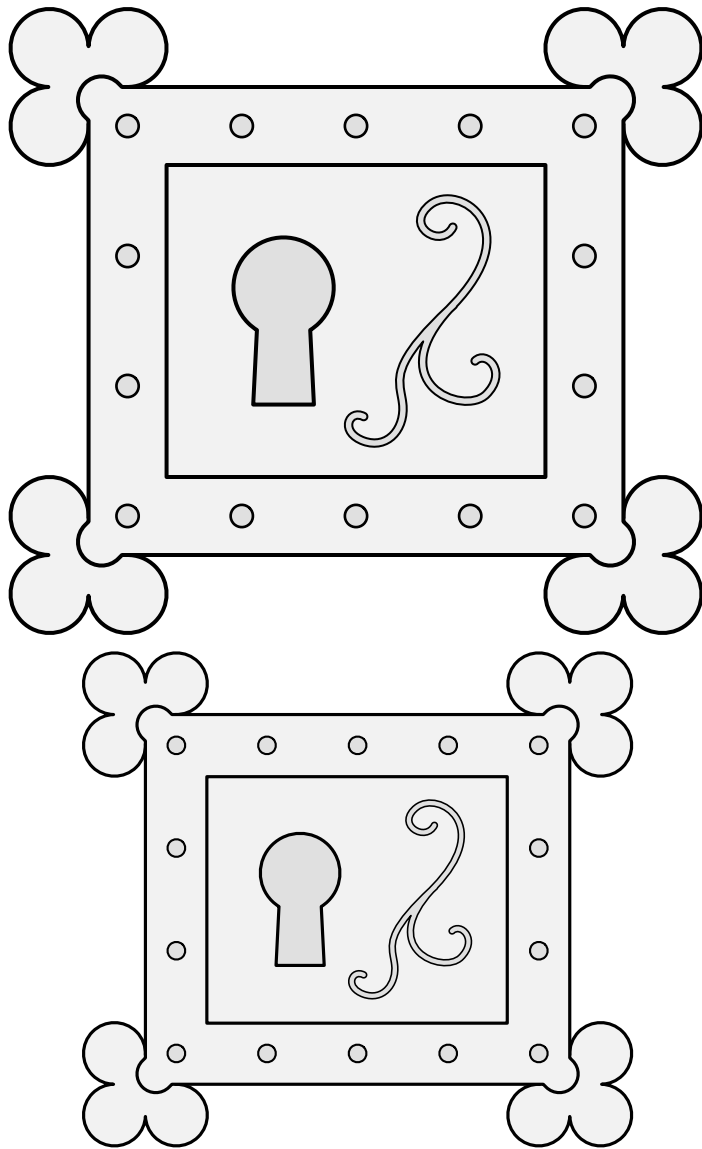

The keyhole and protective plate for a lock such as might be found on a door, chest, or strongbox.

Default orientation: flat side to base. No proper coloration.

The keyhole is often a contrasting tincture.

Source: Dunvegan Armorial. Artist unknown. (Arms of Grierson of Lag, folio 425.)

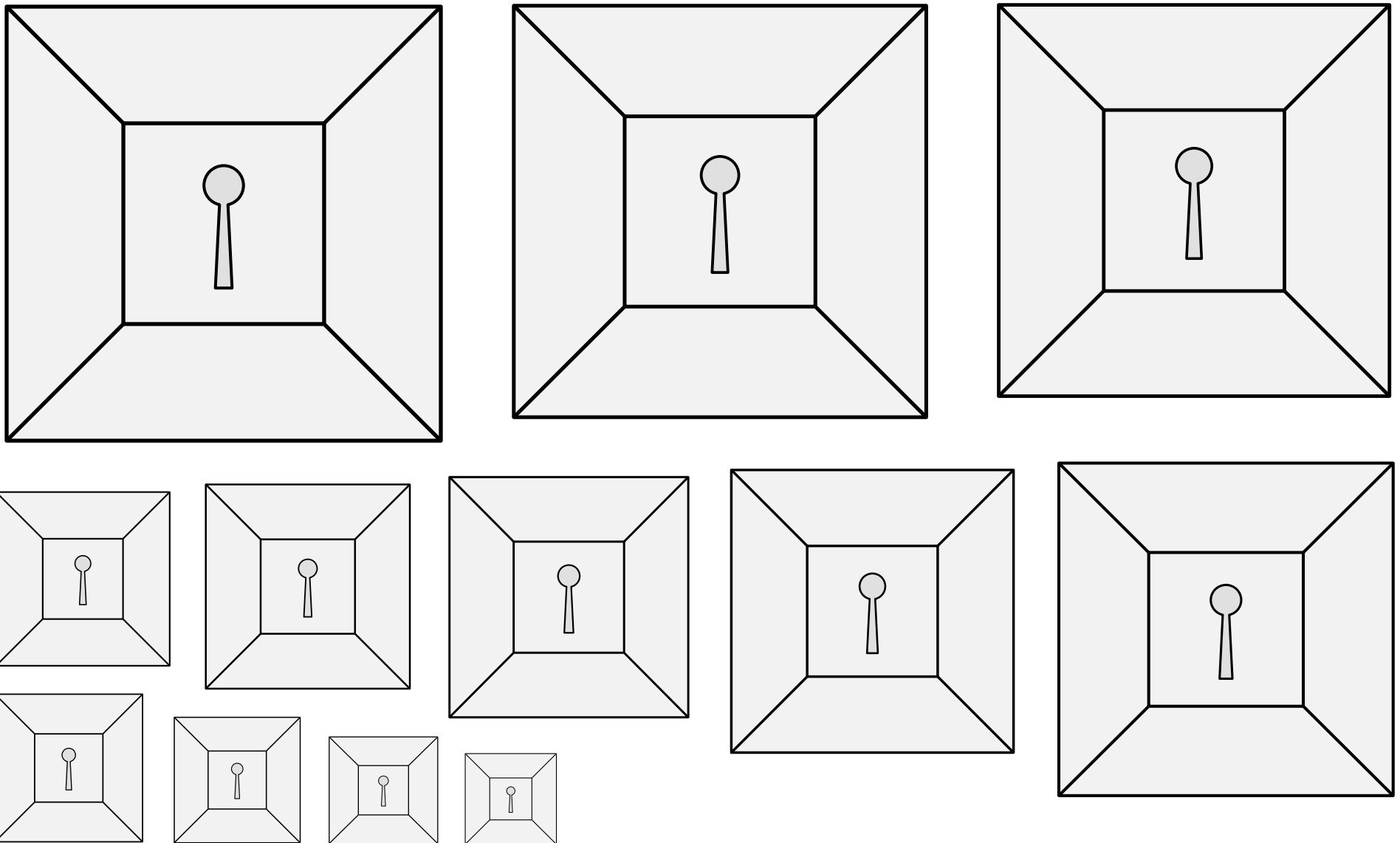

The keyhole and protective plate for a lock such as might be found on a door, chest, or strongbox.

Default orientation: flat side to base. No proper coloration. The keyhole is often a contrasting tincture.

Source: Simon Händel's Wappenbuch. (Folio 94r.)

Artist unknown. Adapted by Iago ab Adam.

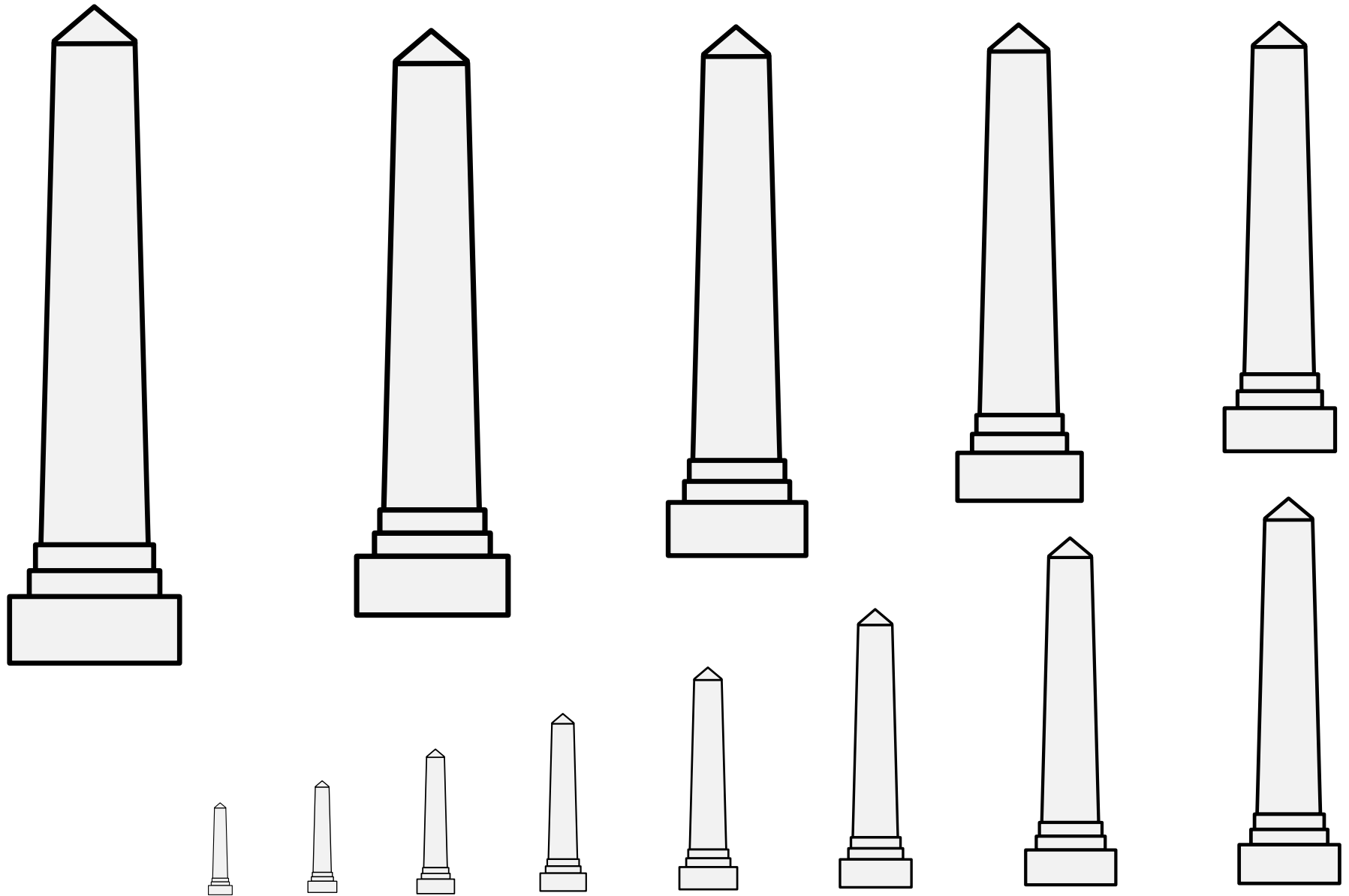

A commemorative stone pillar.

Default orientation: point to chief. Proper coloration: argent stone.

Source: Viking Answer Lady SVG Images For Heralds. Artist: Gunnvôr silfrahárr.

Obelisk (1) 17.150

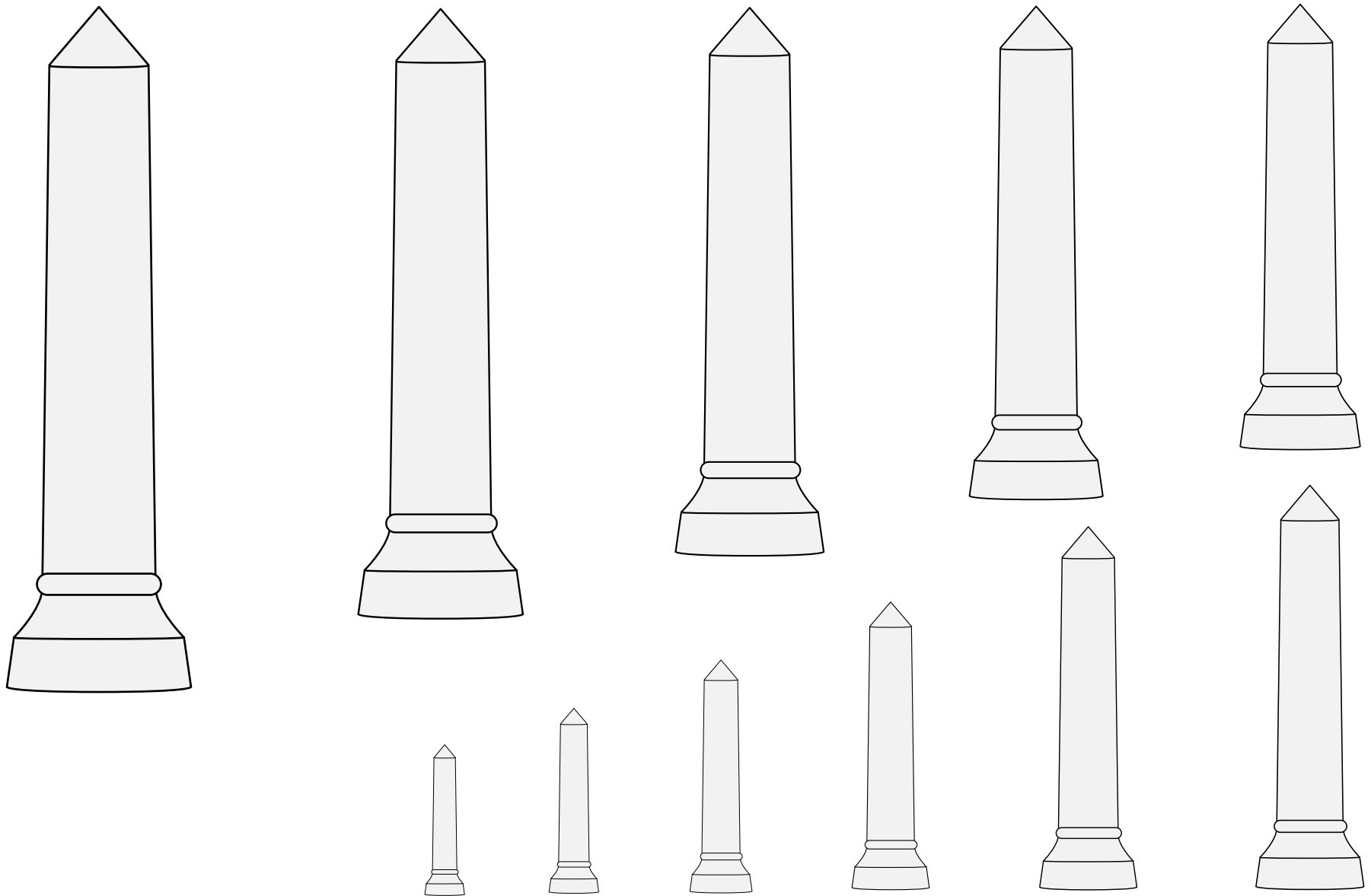

A commemorative stone pillar.

Default orientation: point to chief. Proper coloration: argent stone.

Obelisk (2) 17.151

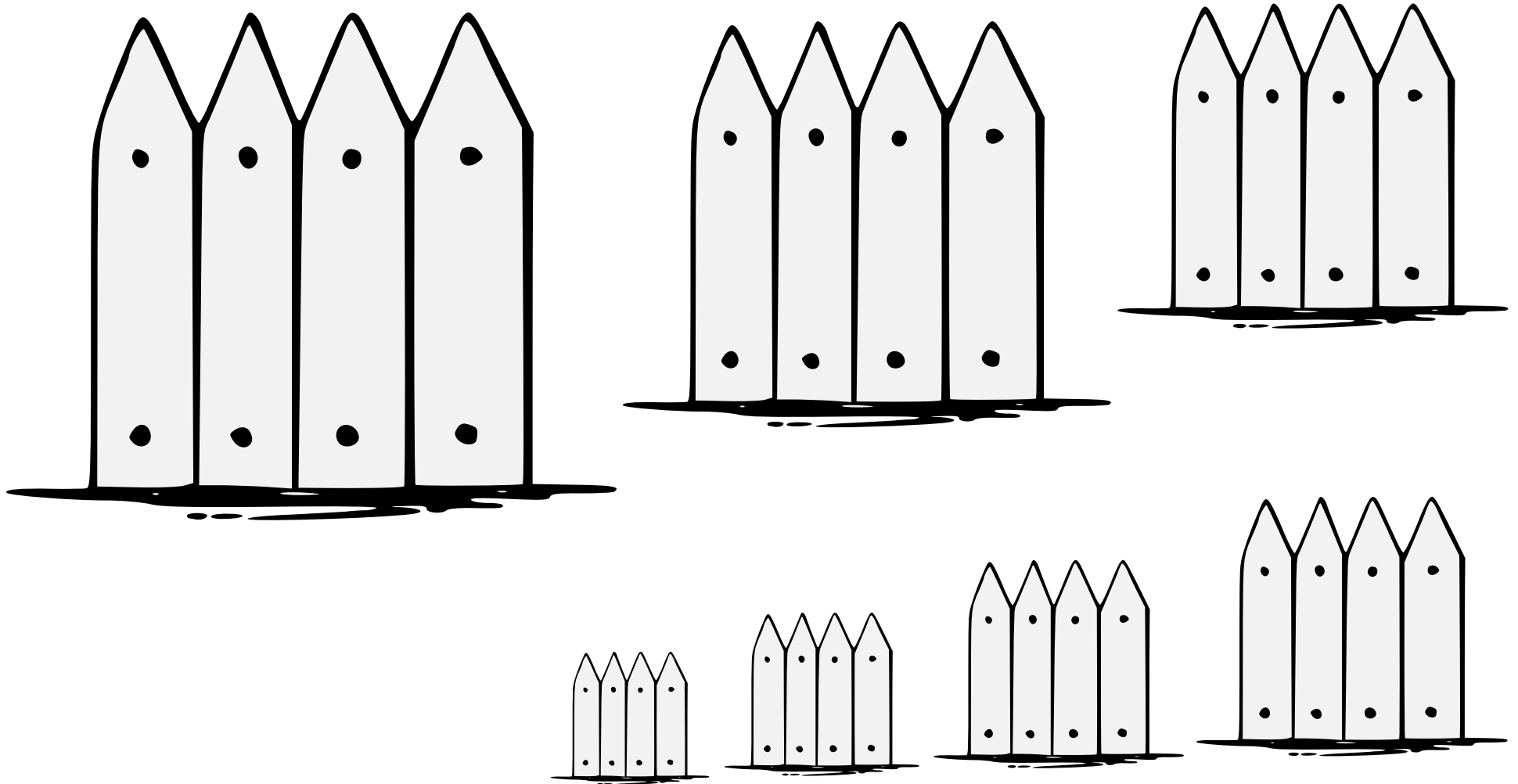

A series of pickets erected as fence to keep intruders off a lawn.

Default orientation: palewise. No proper coloration.

Source: A Glossary of Terms Used in Heraldry. Artist: James or Irene Parker.

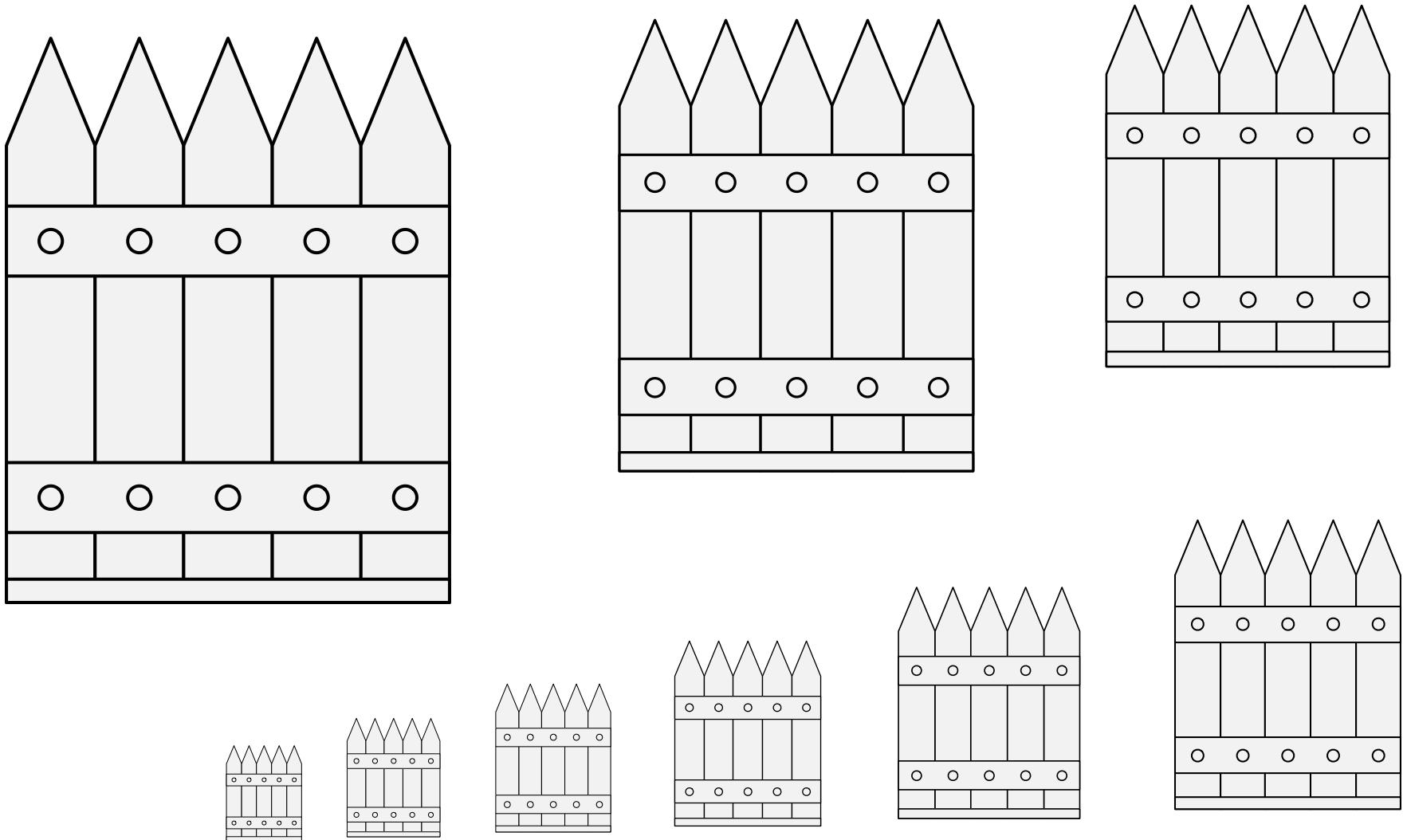

A series of pickets erected as fence to keep intruders off a lawn.

Default orientation: palewise. No proper coloration.

Source: BnF MS Allemand 304. Artist unknown. (Page 690.)

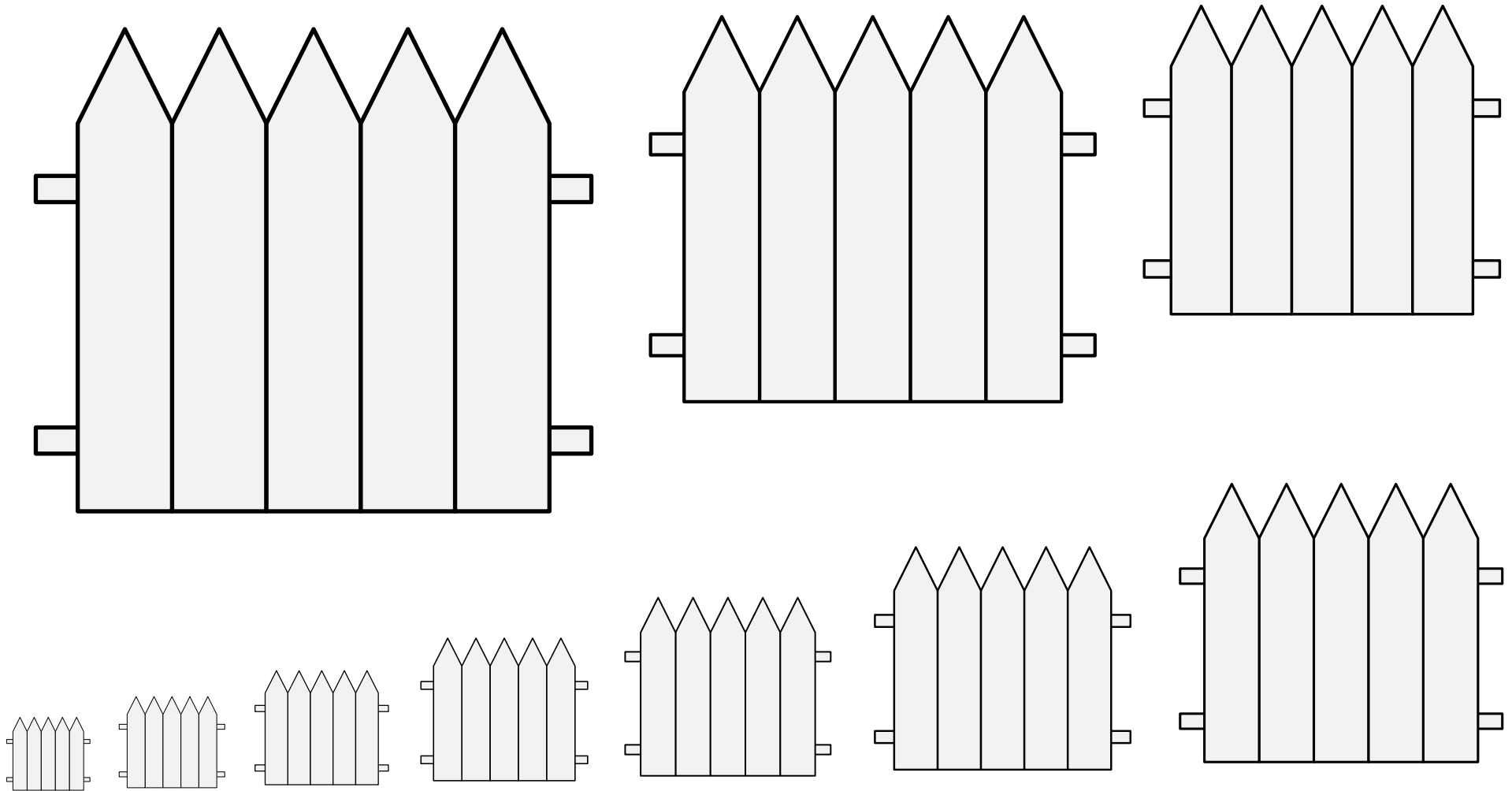

A series of pickets erected as fence to keep intruders off a lawn.
Default orientation: palewise. No proper coloration.
Source: Wernigerode Armorial. Artist unknown. (Folio 253v.)

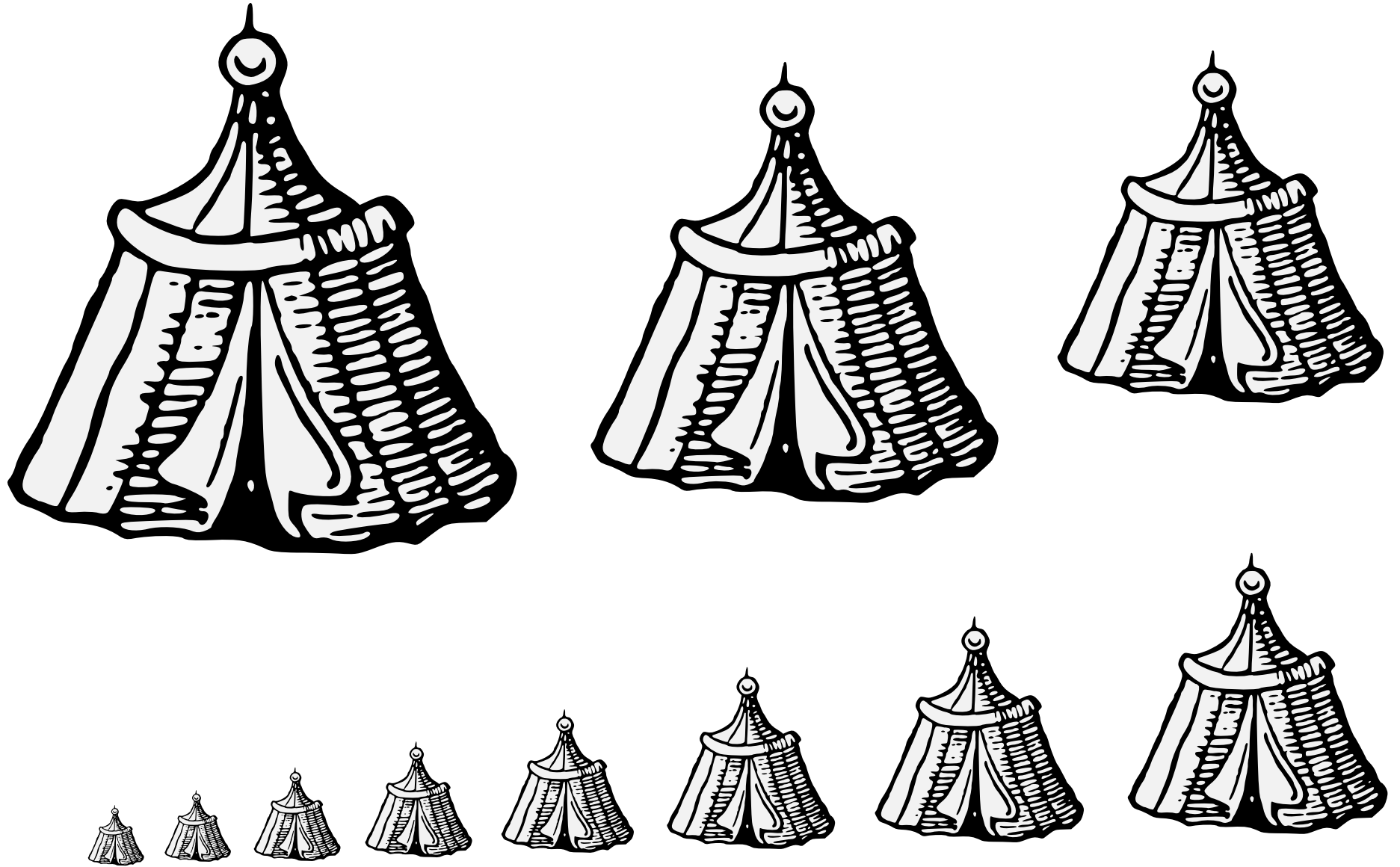

A portable dwelling constructed of poles and fabric. May also be blazoned simply "a tent."

Default orientation: upright. No proper coloration.

Source: Guillim's Display of Heraldry. Artist unknown.

Pavilion (1) 17.155

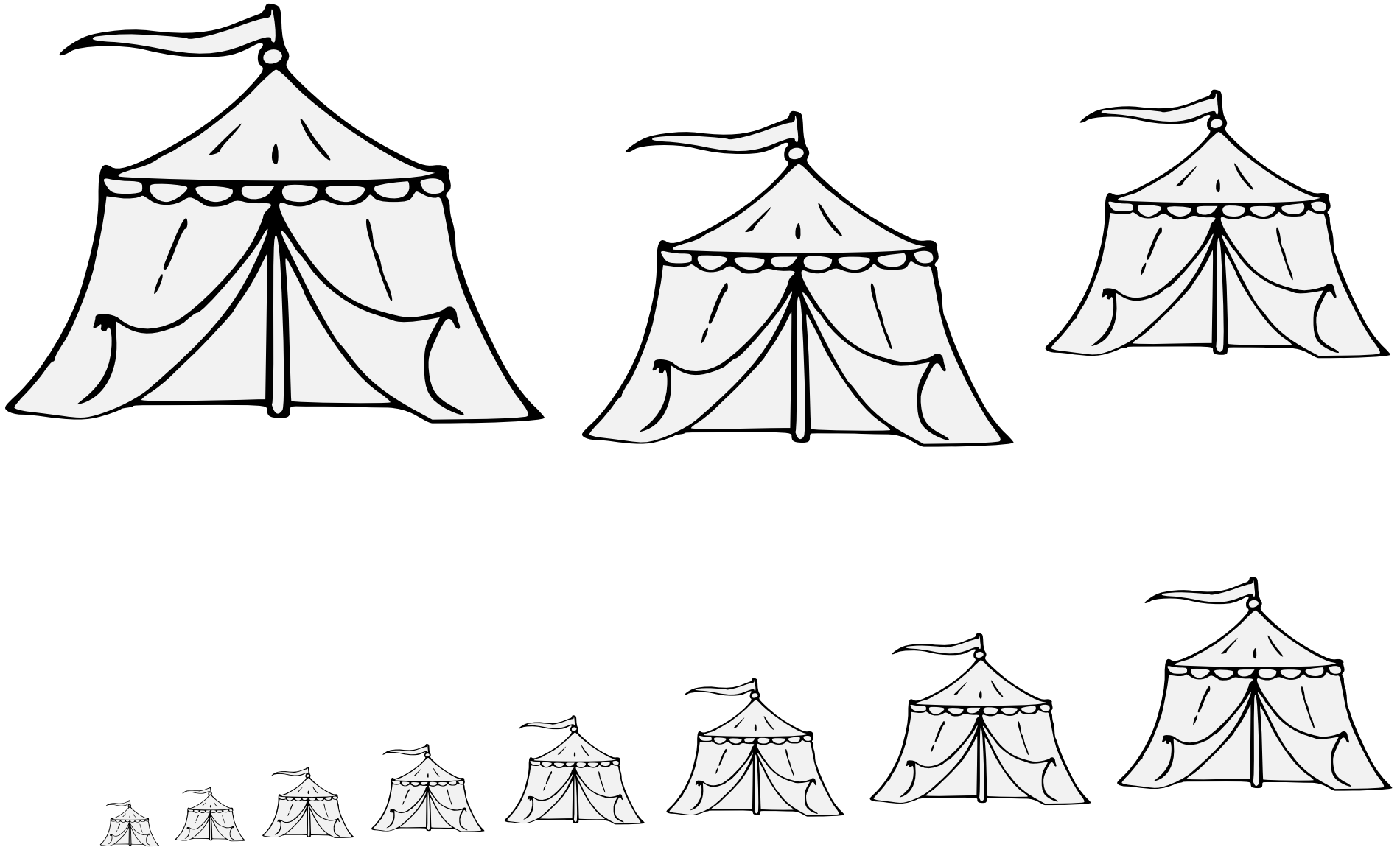

A portable dwelling constructed of poles and fabric. May also be blazoned simply "a tent."

Default orientation: upright. No proper coloration.

Source: Pennsic Traceable Art. Artist: Roana d'Evreux.

Pavilion (2) 17.156

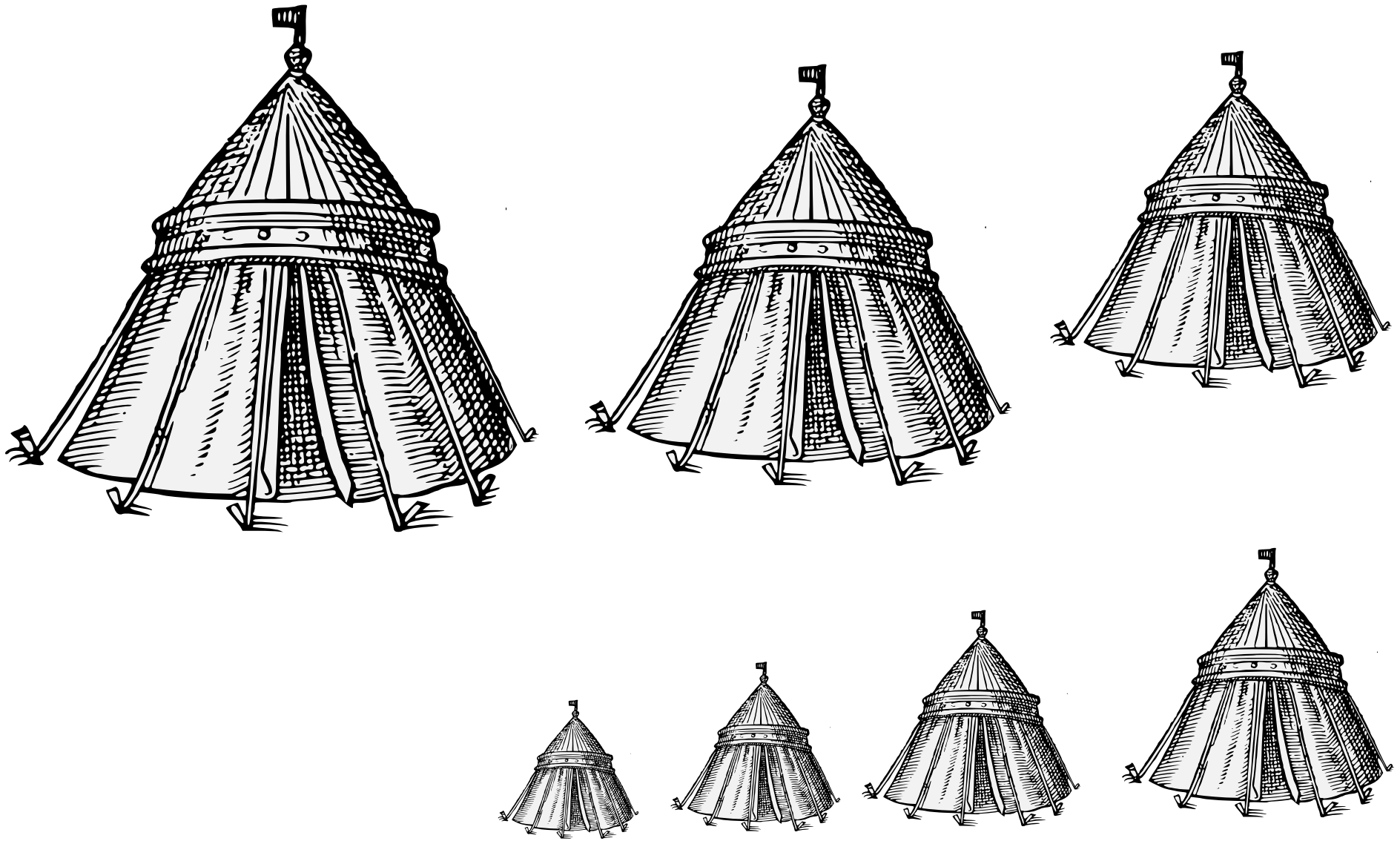

A portable dwelling constructed of poles and fabric.
Default orientation: upright. No proper coloration.
Source: Le Blason Des Armoiries. Artist: Jérôme de Bara.

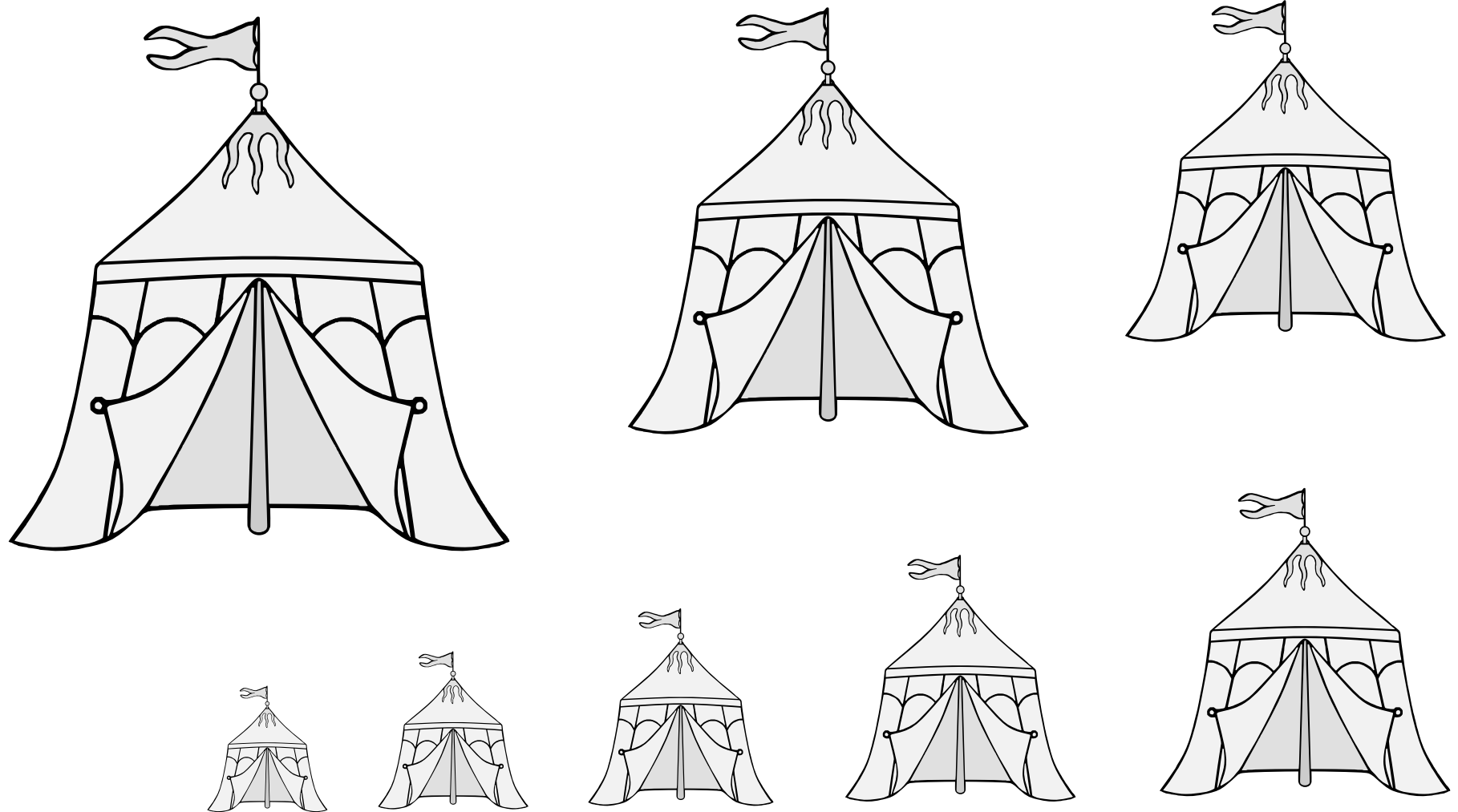

A portable dwelling constructed of poles and fabric.
Default orientation: upright. No proper coloration.
Artist: Jessimond of Emerickeskepe.

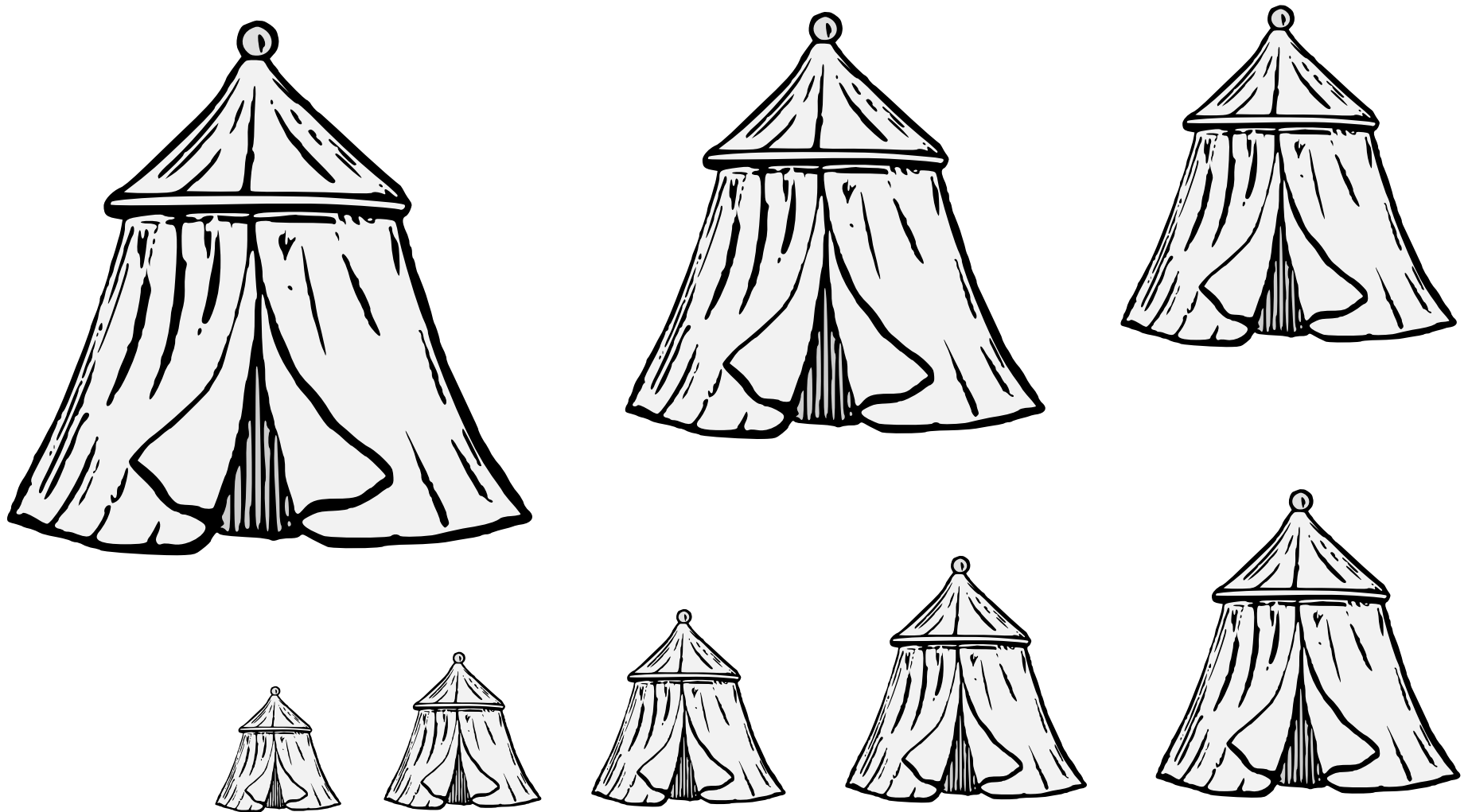

A portable dwelling constructed of poles and fabric.

Default orientation: upright. No proper coloration.

Source: Encyclopædia Heraldica. (Volume 3, plate XXX.) Artist unknown.

Pavilion (5) 17.159

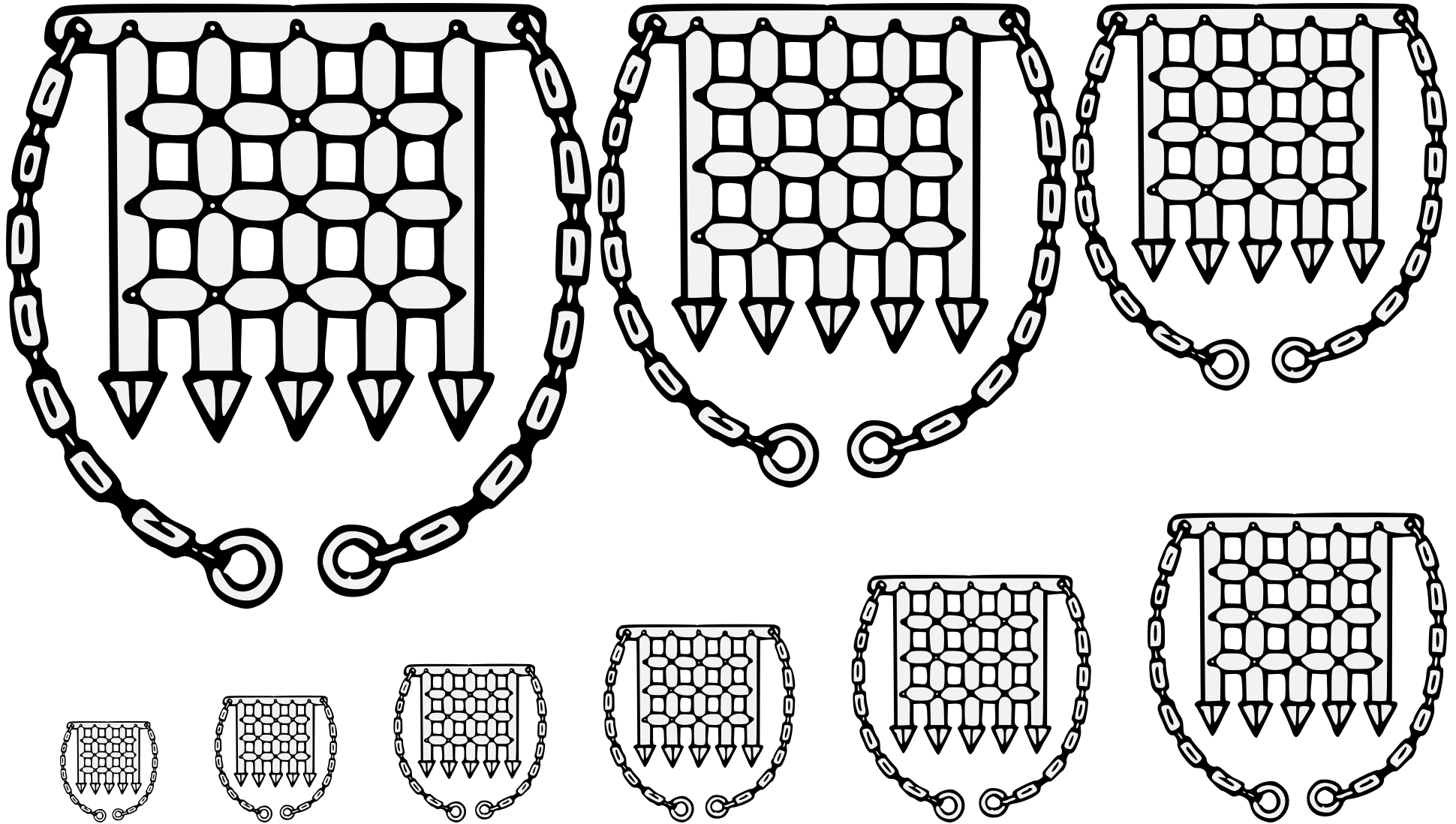

A heavy gate that may be raised or lowered to control access to a castle.

By default portcullises have chains hanging from each of the upper corners, unless blazoned otherwise.

Default orientation: upright. No proper coloration.

Source: A Complete Guide to Heraldry. Artist: Graham Johnston.

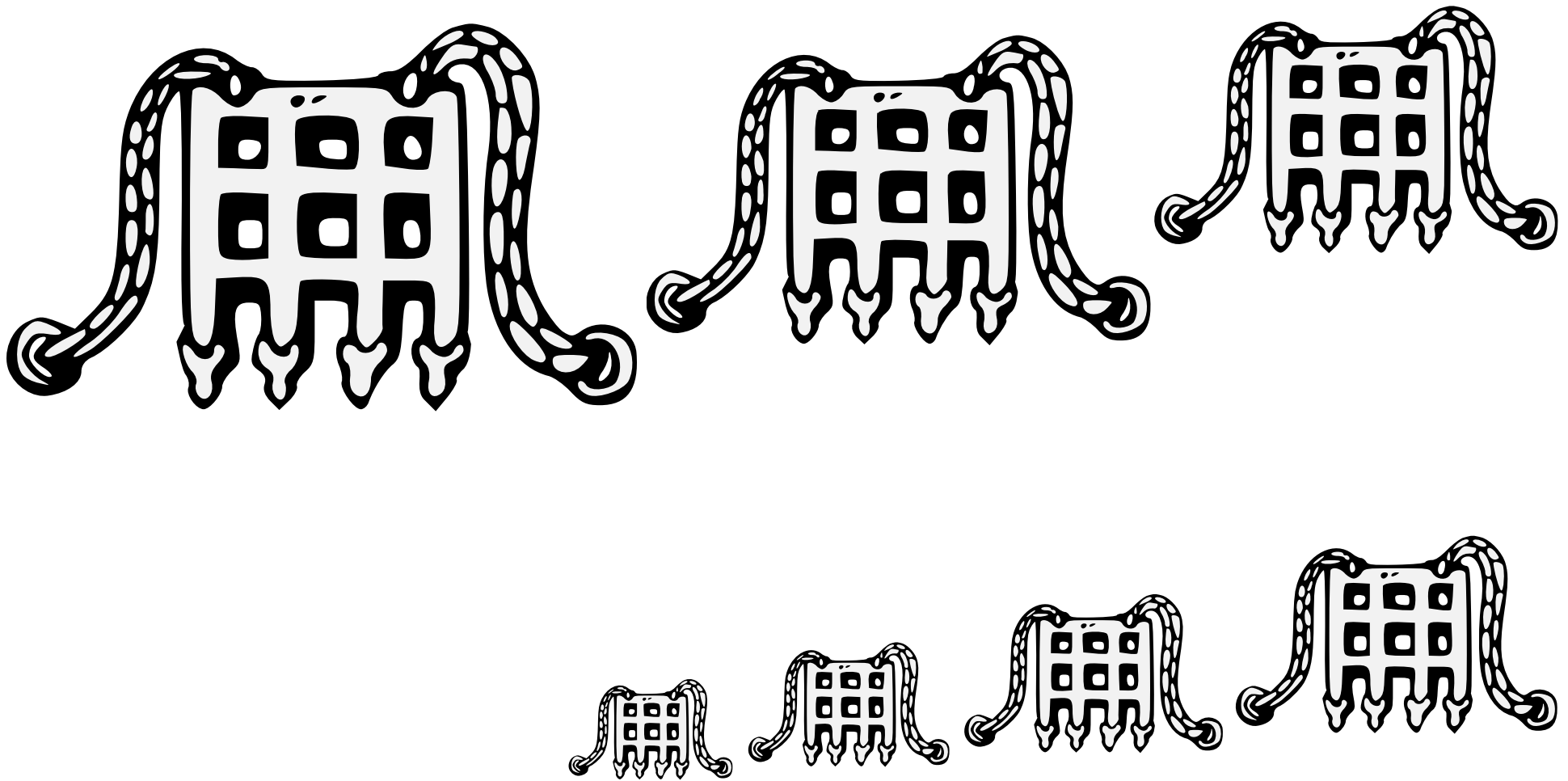

A heavy gate that may be raised or lowered to control access to a castle.

By default portcullises have chains hanging from each of the upper corners, unless blazoned otherwise.

Default orientation: upright. No proper coloration.

Source: Banners, Standards, and Badges. Artist: Thomas Willement.

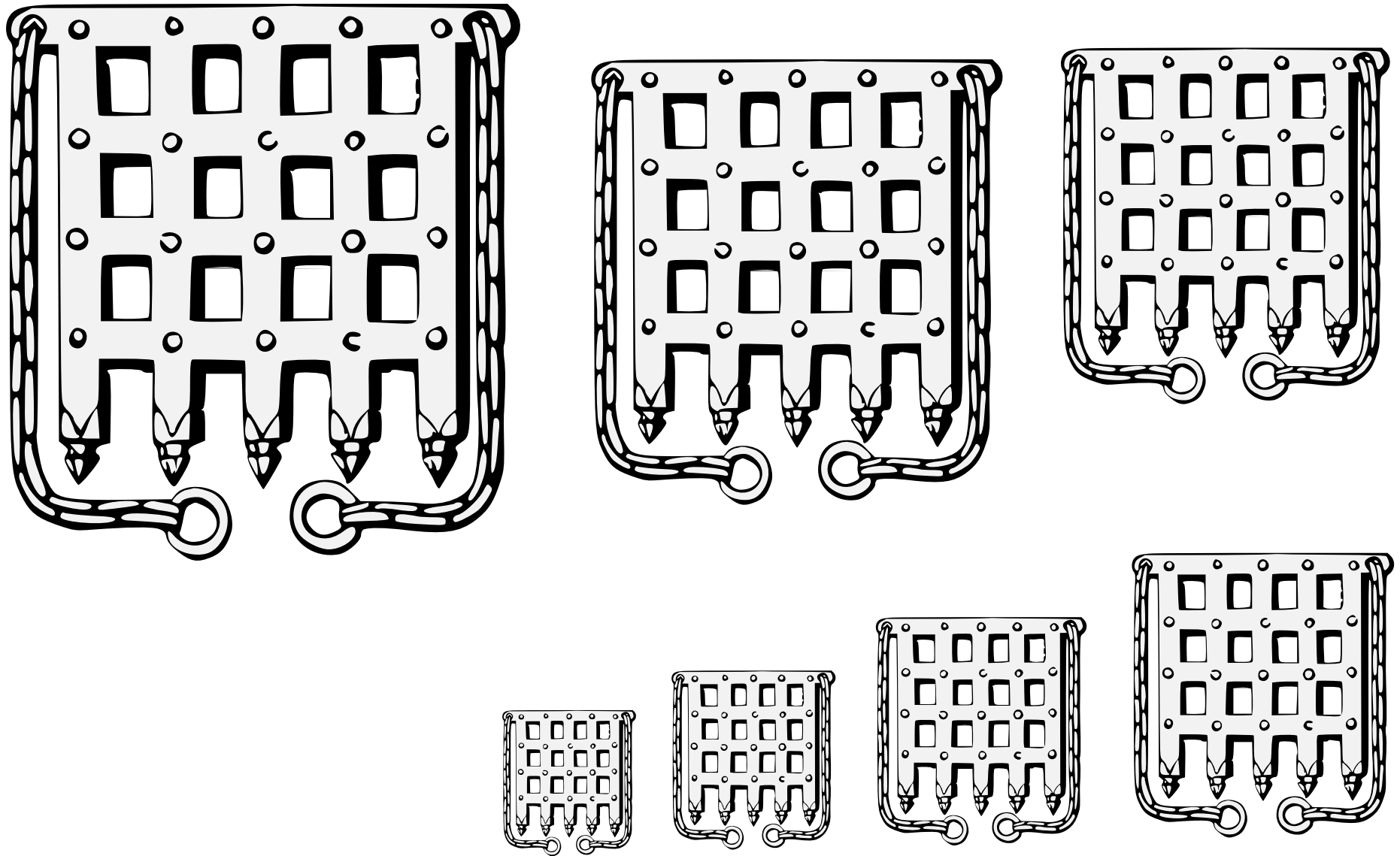

A heavy gate that may be raised or lowered to control access to a castle.

By default portcullises have chains hanging from each of the upper corners, unless blazoned otherwise.

Default orientation: upright. No proper coloration.

Source: A Glossary of Terms Used in Heraldry. Artist: James or Irene Parker.

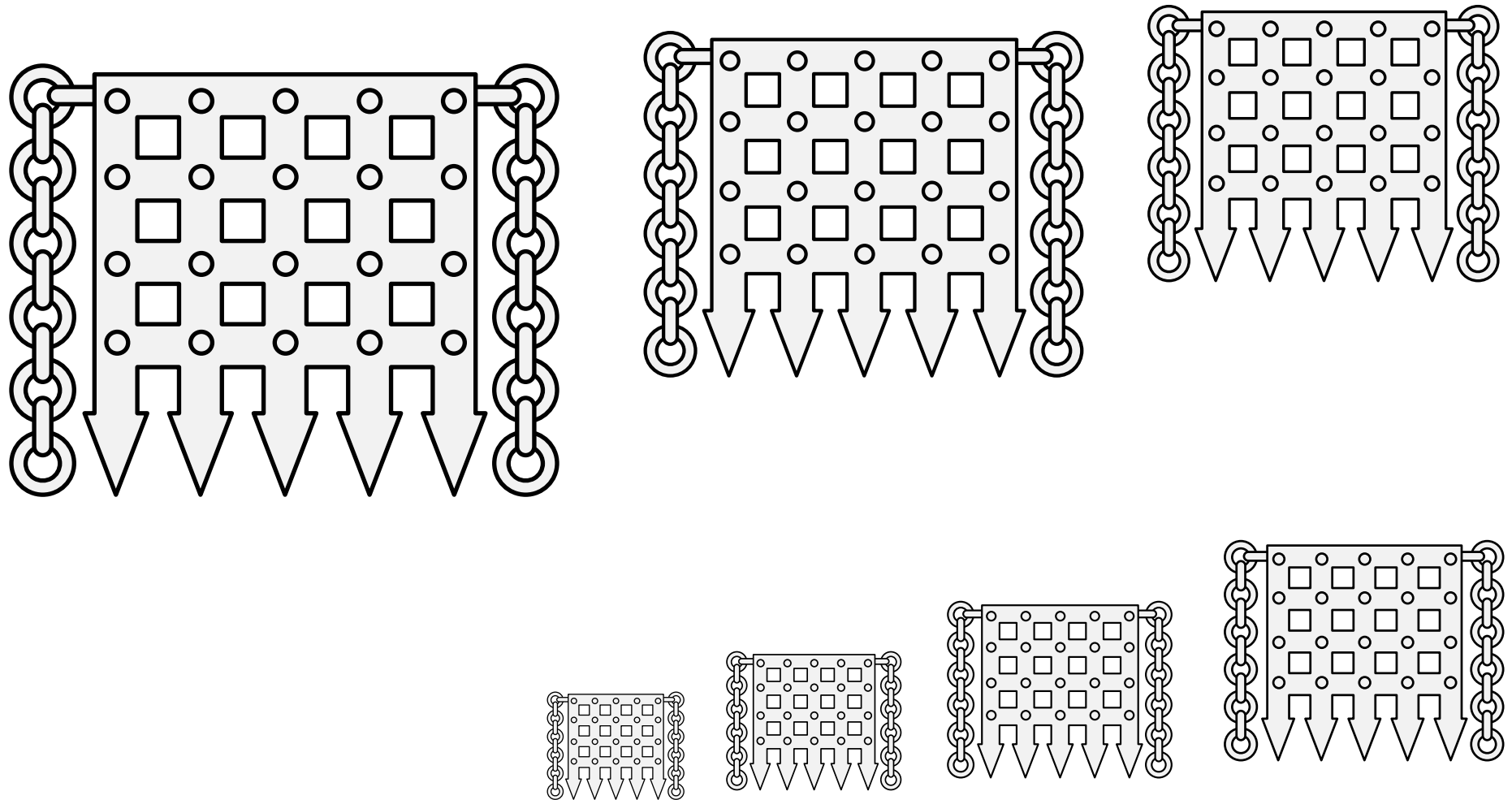

A heavy gate that may be raised or lowered to control access to a castle.

By default portcullises have chains hanging from each of the upper corners, unless blazoned otherwise.

Default orientation: upright. No proper coloration.

Source: Viking Answer Lady SVG Images For Heraldry. Artist: Gunnvôr silfráhr.

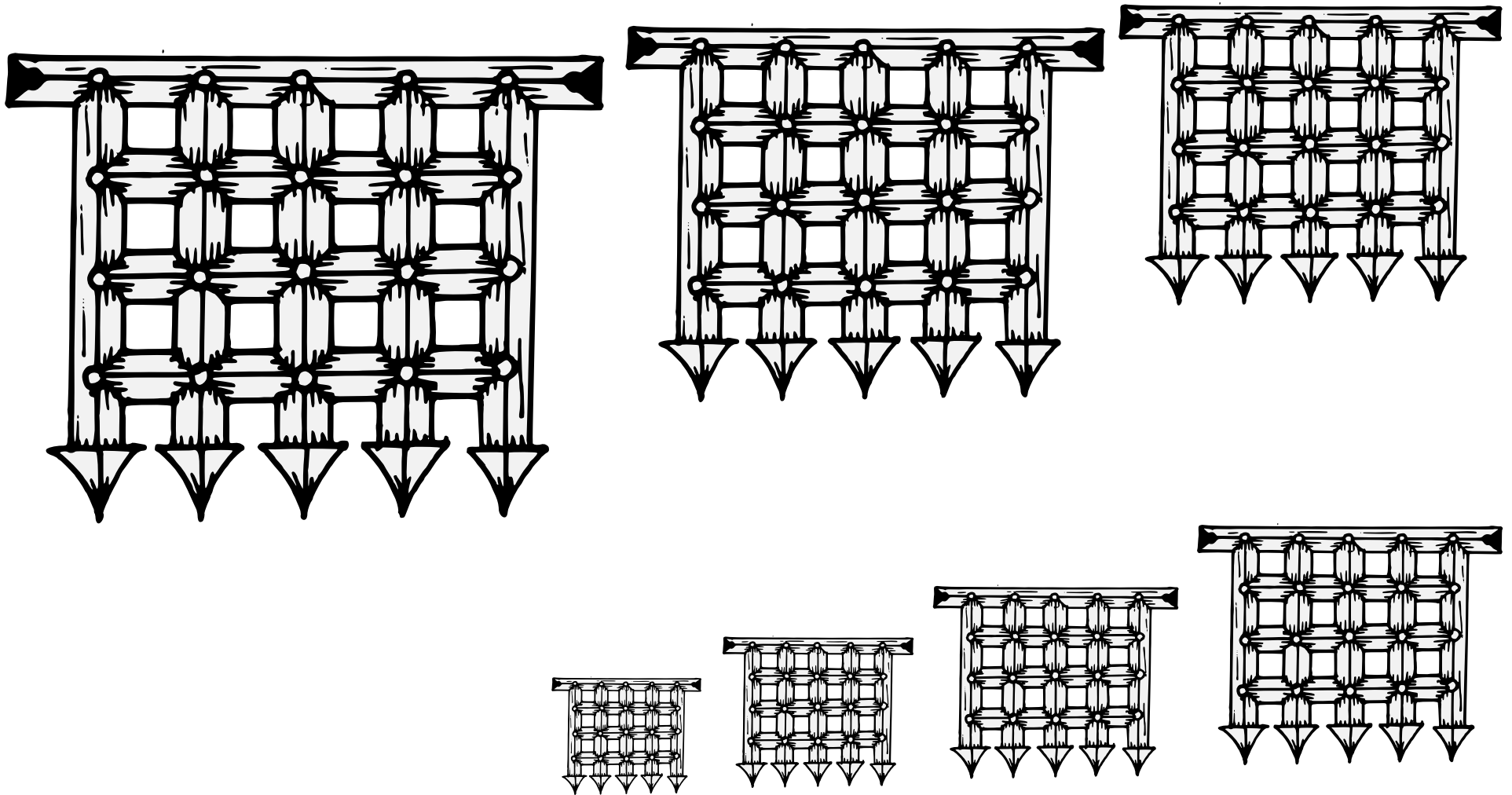

A heavy gate that may be raised or lowered to control access to a castle.

By default portcullises have chains hanging from each of the upper corners, unless blazoned otherwise.

Default orientation: upright. No proper coloration.

Source: Heraldic Templates. Artist: Torric inn Björn.

Portcullis, Chainless 17.164

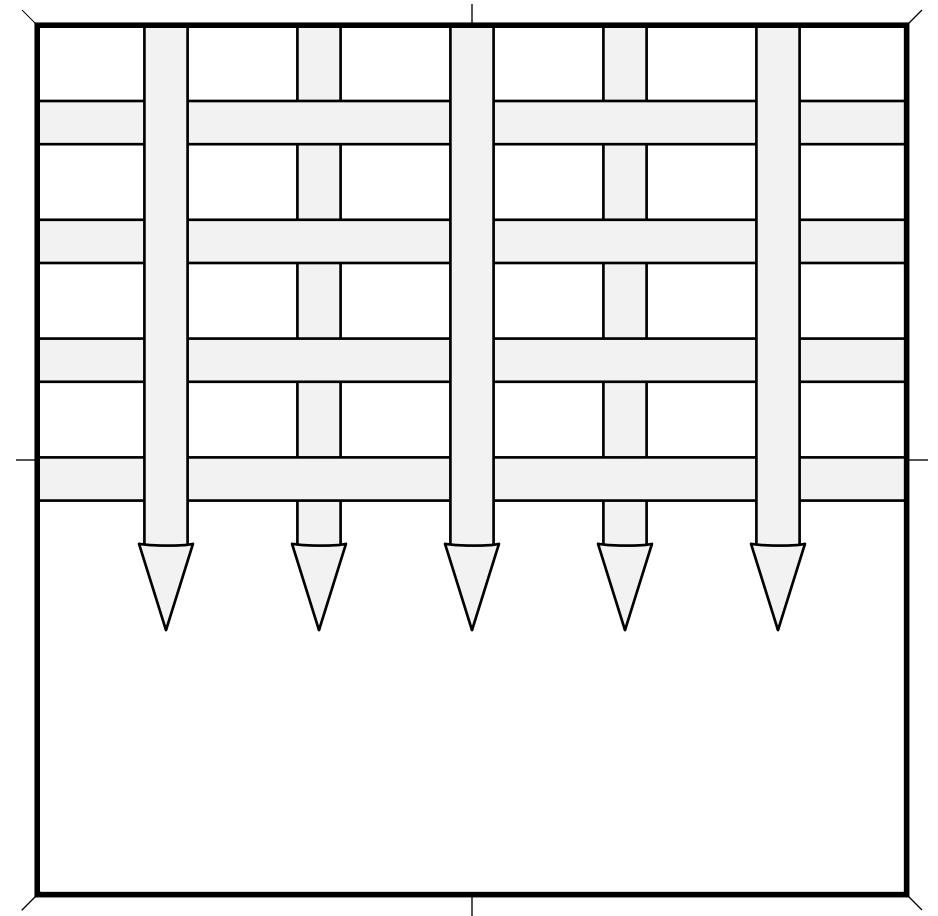
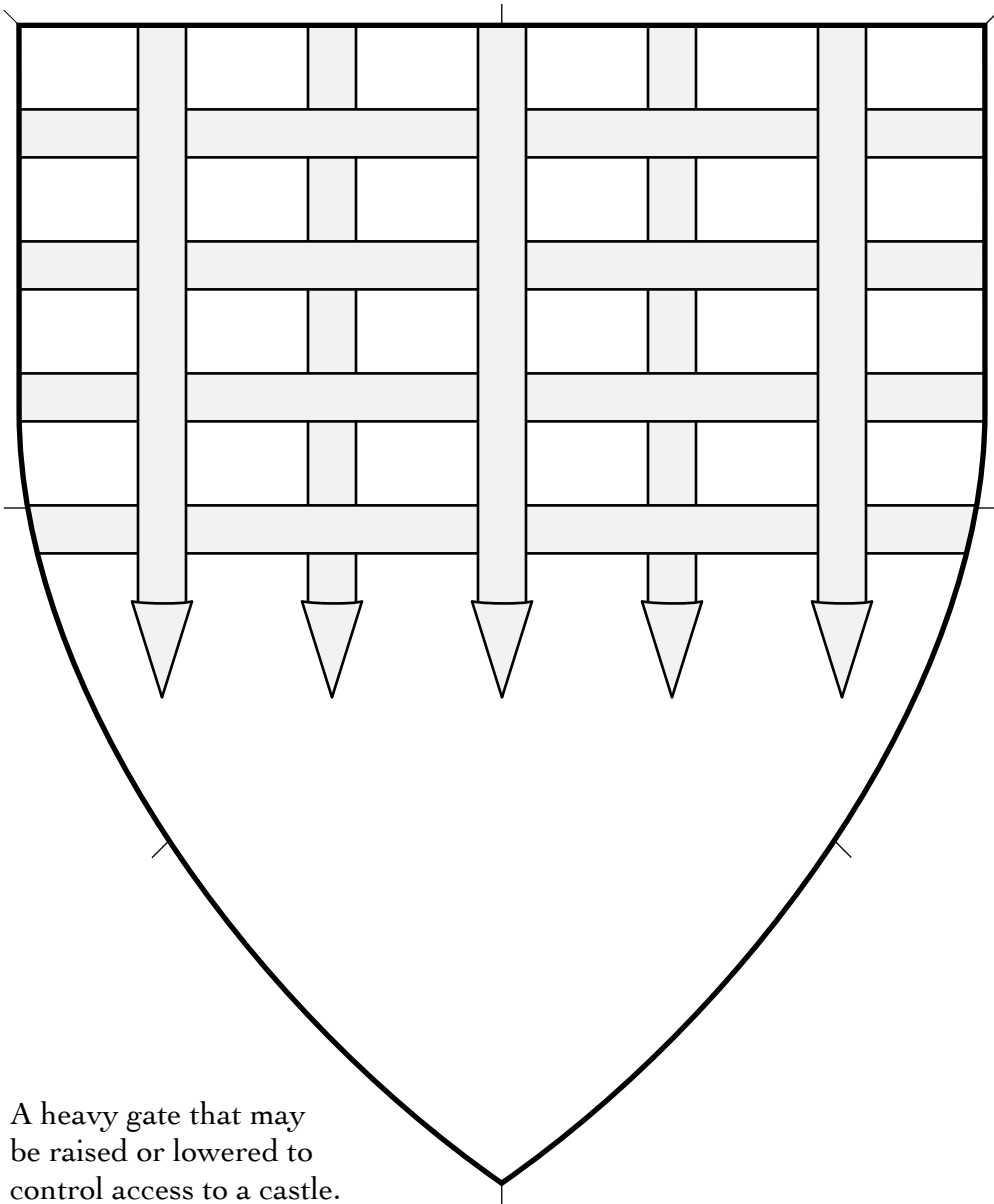

A heavy gate that may be raised or lowered to control access to a castle.

By default portcullises have chains hanging from each of the upper corners, unless blazoned otherwise.

Default orientation: upright. No proper coloration.

Source: Wappenbuch der Arlberg-Bruderschaft.
Artist: Vigil Raber. (Folio 49r.)

Portcullis Throughout (1) 17.165

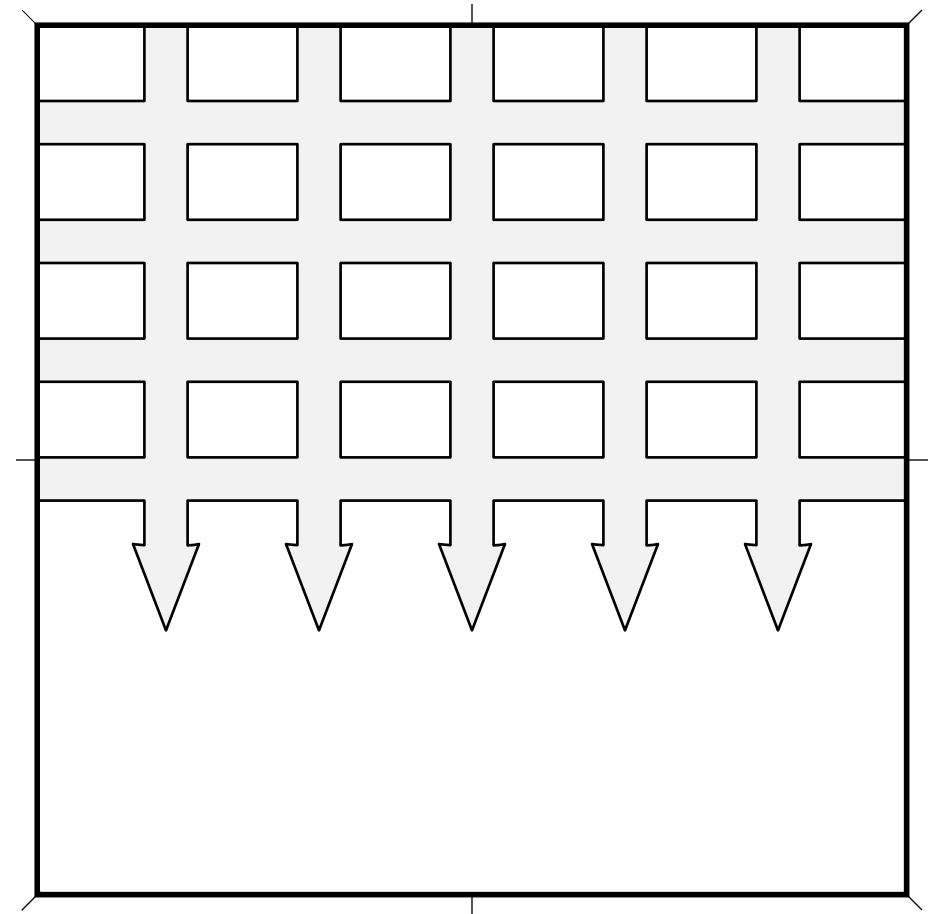
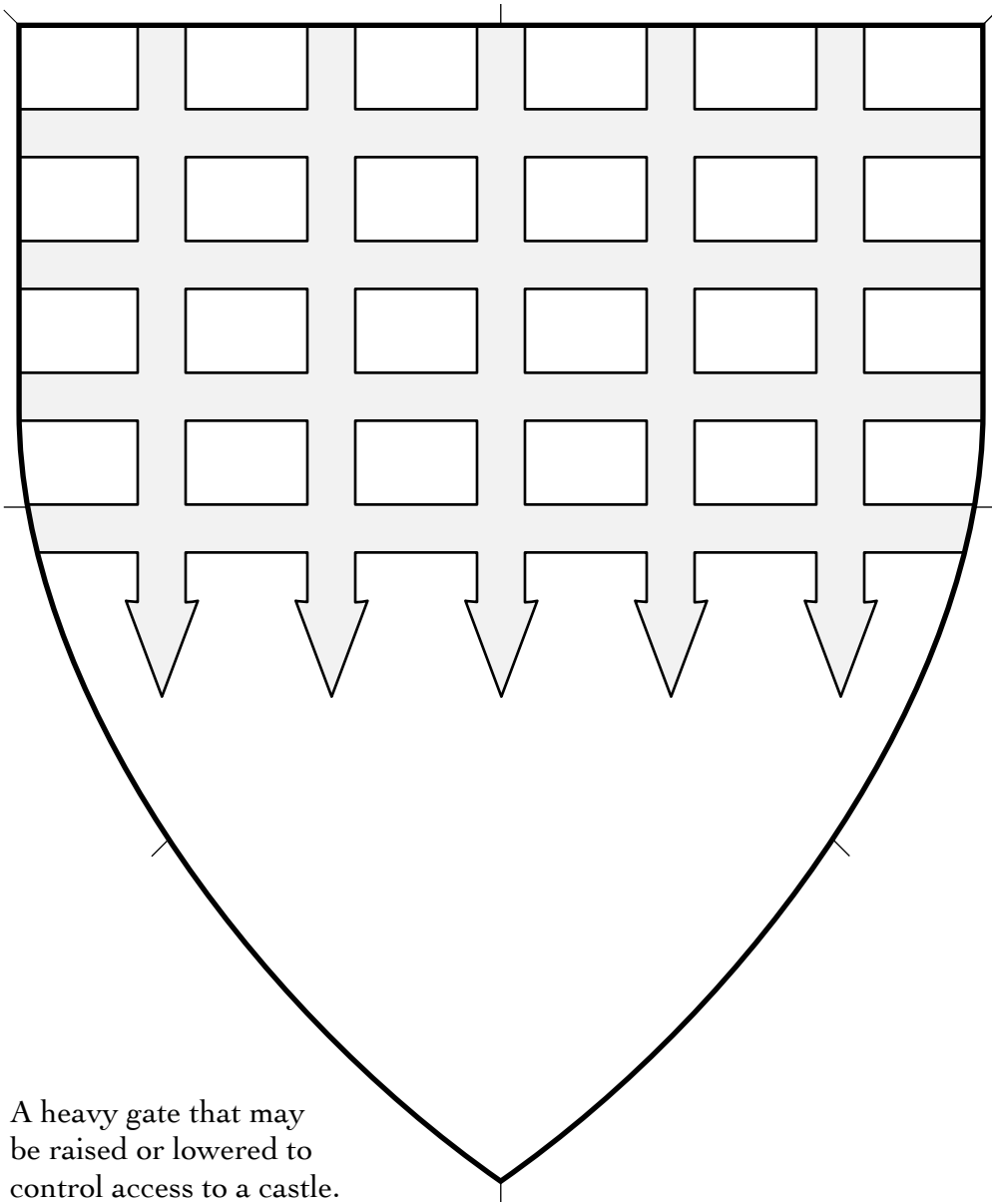

A heavy gate that may be raised or lowered to control access to a castle.

By default portcullises have chains hanging from each of the upper corners, unless blazoned otherwise.

Default orientation: upright. No proper coloration.

Source: Wappenbuch der Arlberg-Bruderschaft.
Artist: Vigil Raber. (Folio 49r.)

Portcullis Throughout (2) 17.166

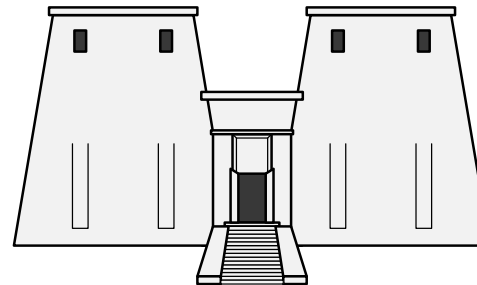
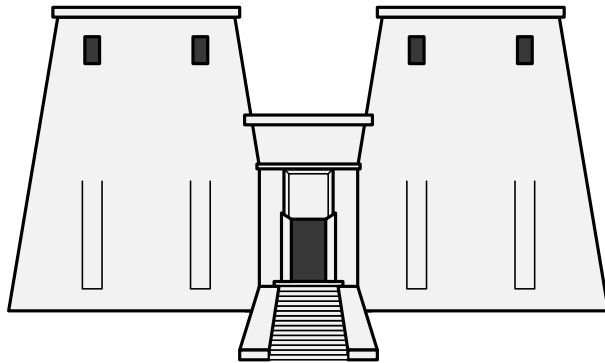
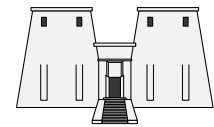
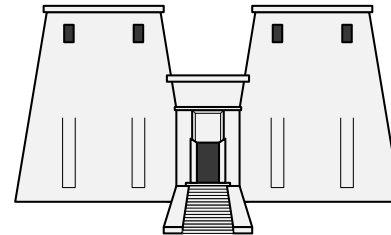
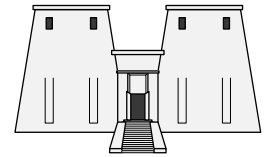
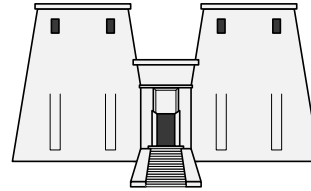
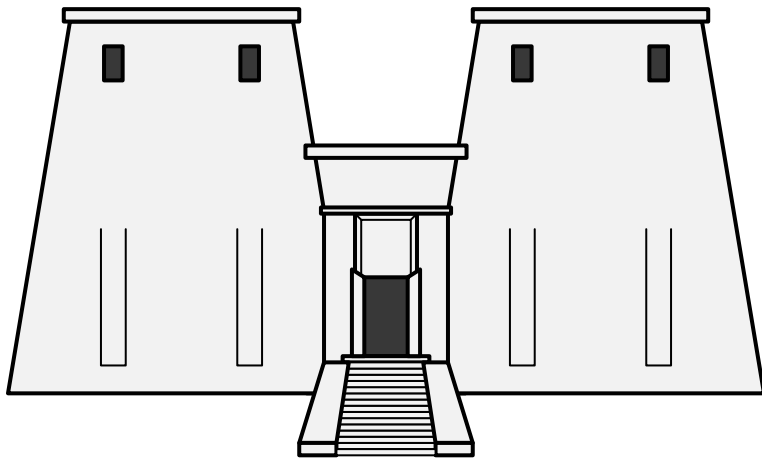

A large stone structure that served as an ornamental gate to an ancient Egyptian temple.
Default orientation: upright. No proper coloration; .

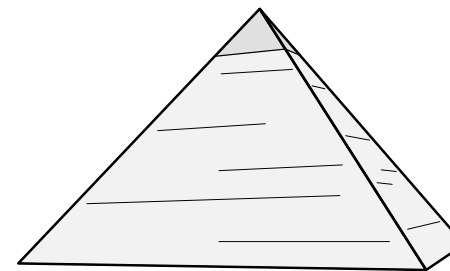
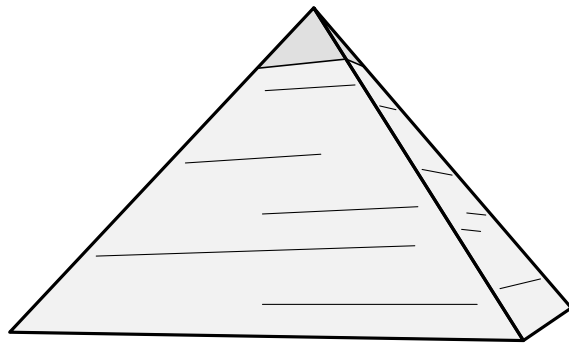
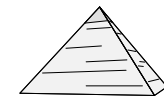
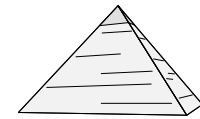
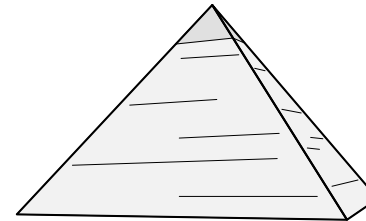
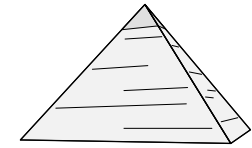
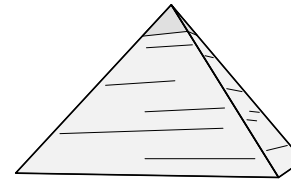
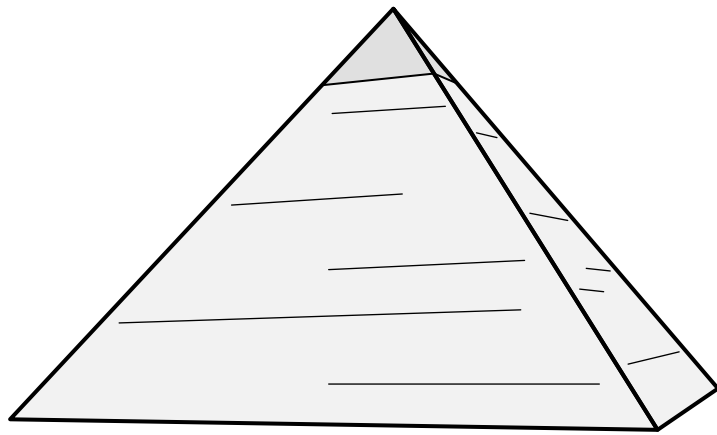

An imposing ceremonial building that tapers to a point.
Variations on these structures are found in many parts of the world.
Default orientation: point to chief. No proper coloration.

Pyramid, Egyptian 17.168

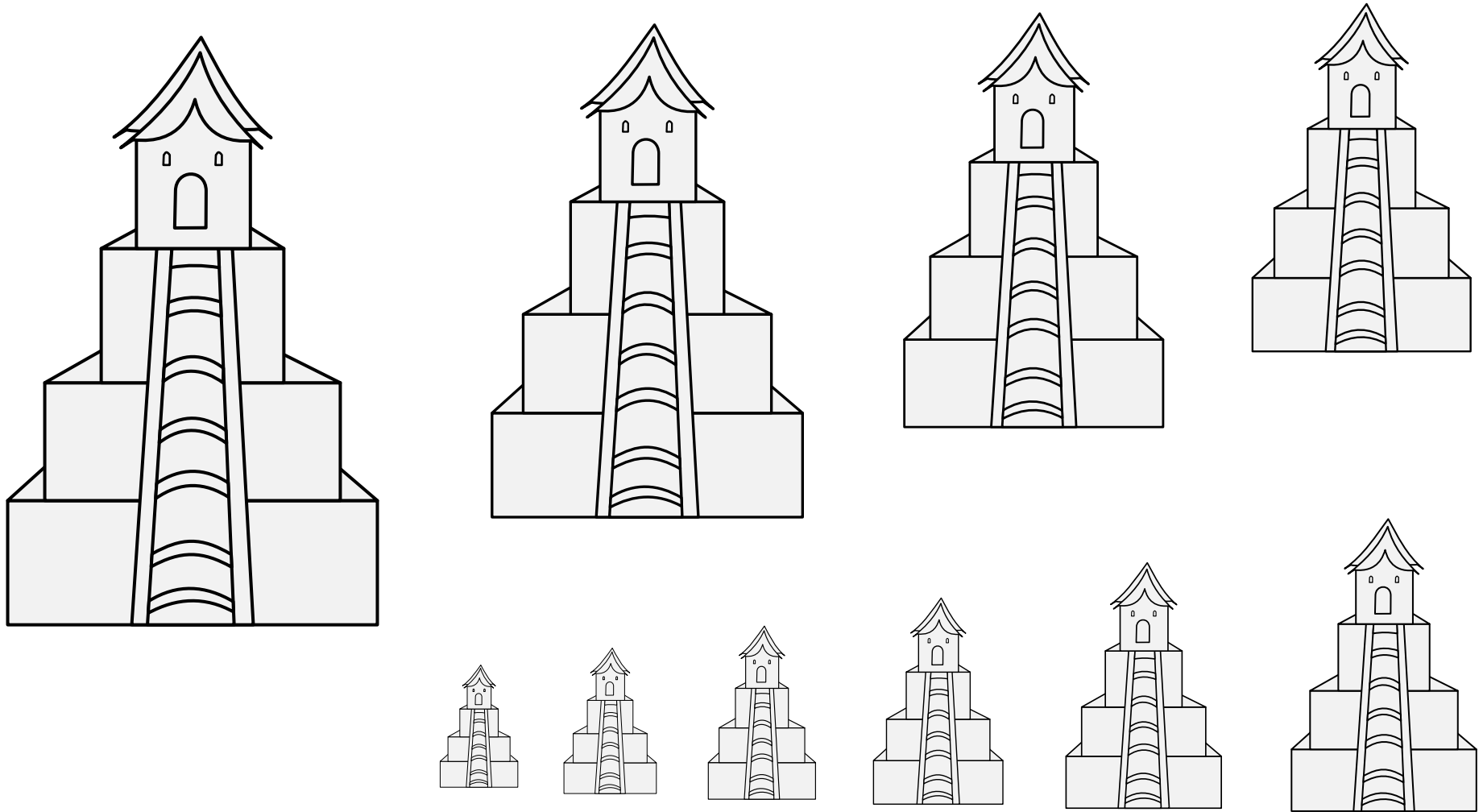

An imposing ceremonial building that tapers to a point.
Variations on these structures are found in many parts of the world.

Default orientation: point to chief. No proper coloration.

Source: Archivo General de Indias.
(Arms of Pedro Lozano, 1539.)

Artist unknown. Adapted by Iago ab Adam.

Pyramid, Stepped 17.169

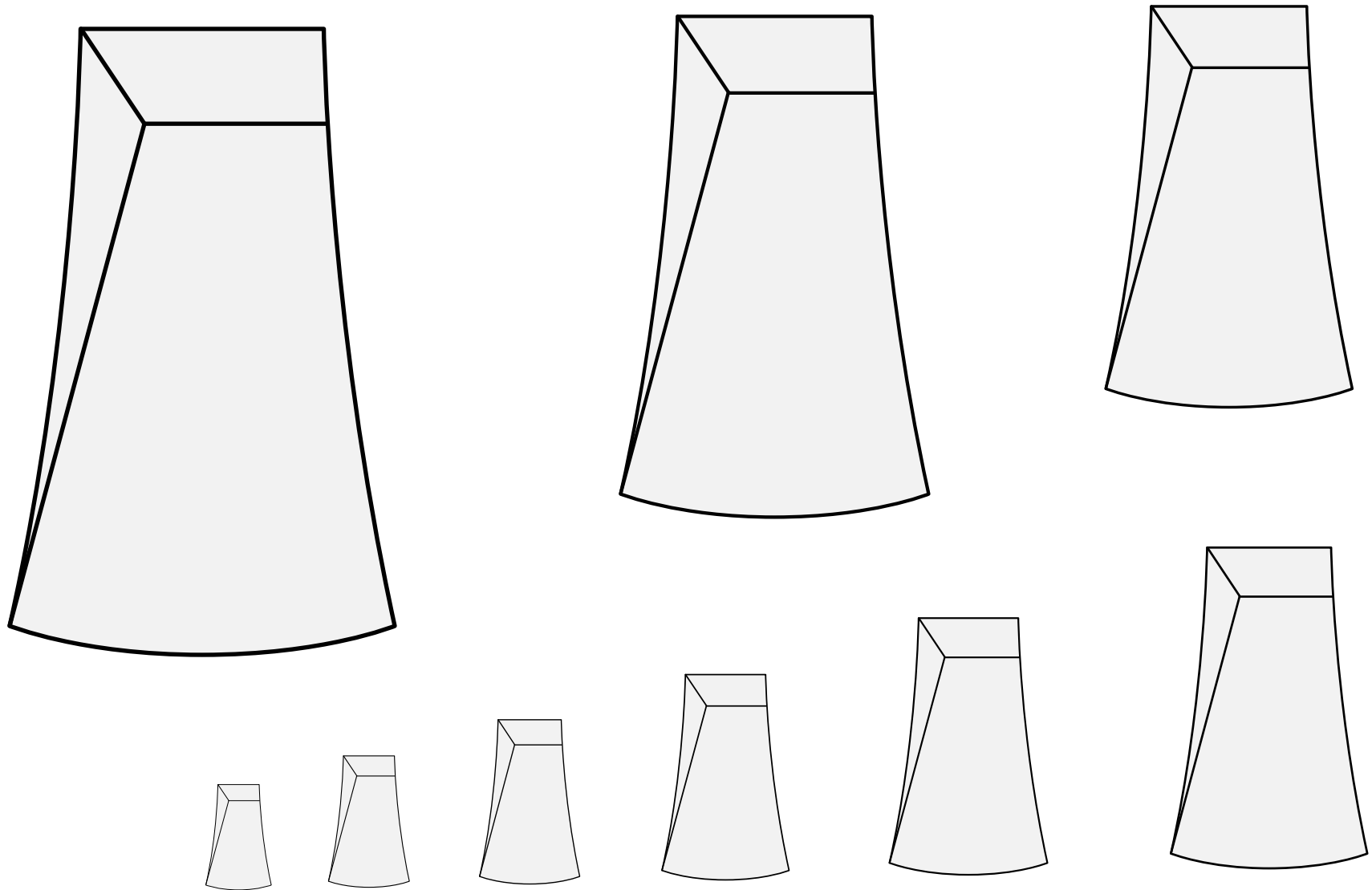

A wedge-shaped cornerstone found in Iberian armory.

Default orientation: narrow edge to chief. No proper coloration.

Source: Livro do Armeiro-Mor. Artist: Jean Du Cros. (Arms of Cunha, folio 51v.)

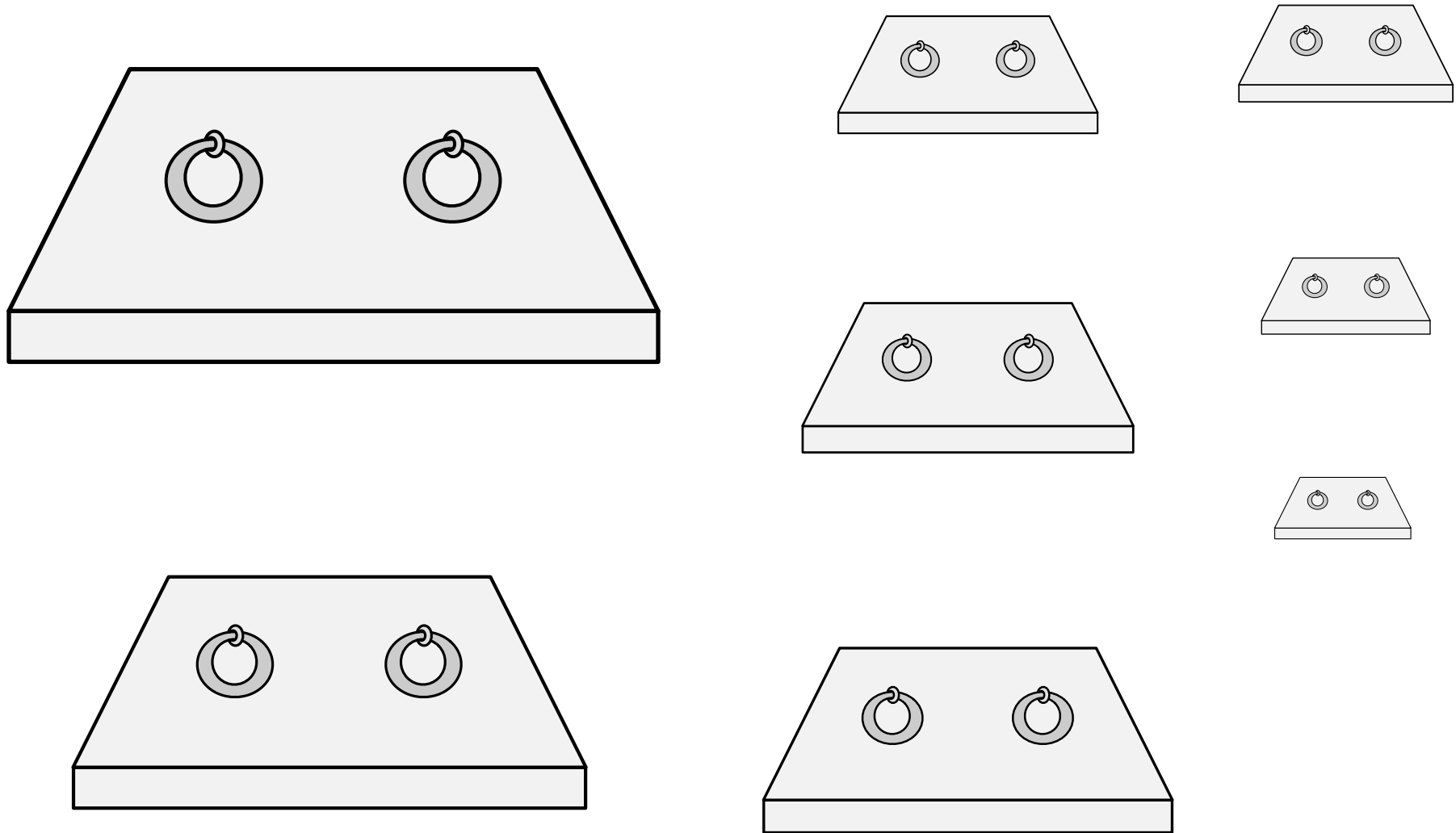

A heavy stone used to seal a tomb, featuring iron rings allowing the stone to be lifted for additional future burials.

Default orientation: fesswise in simplified perspective. Proper coloration: argent stone.

Source: Insignia Nobilium Patavinorum.
Artist unknown. (Arms of Sagra, folio 56.)

Sepulcher Stone 17.171

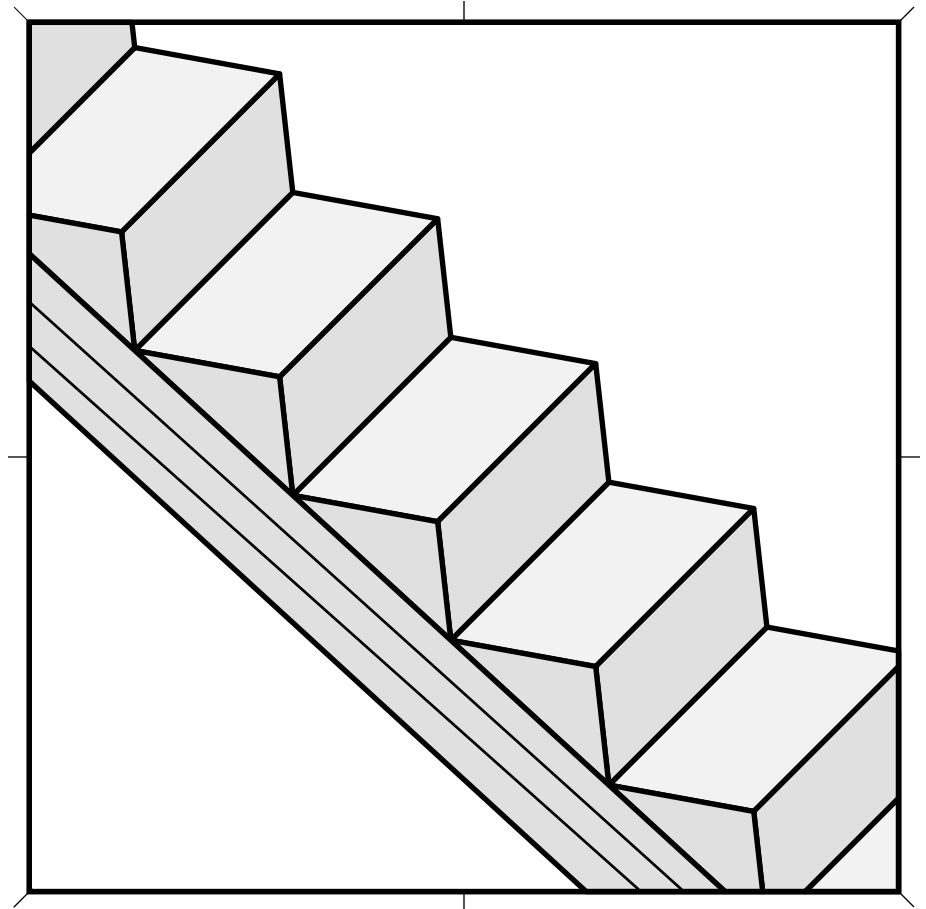
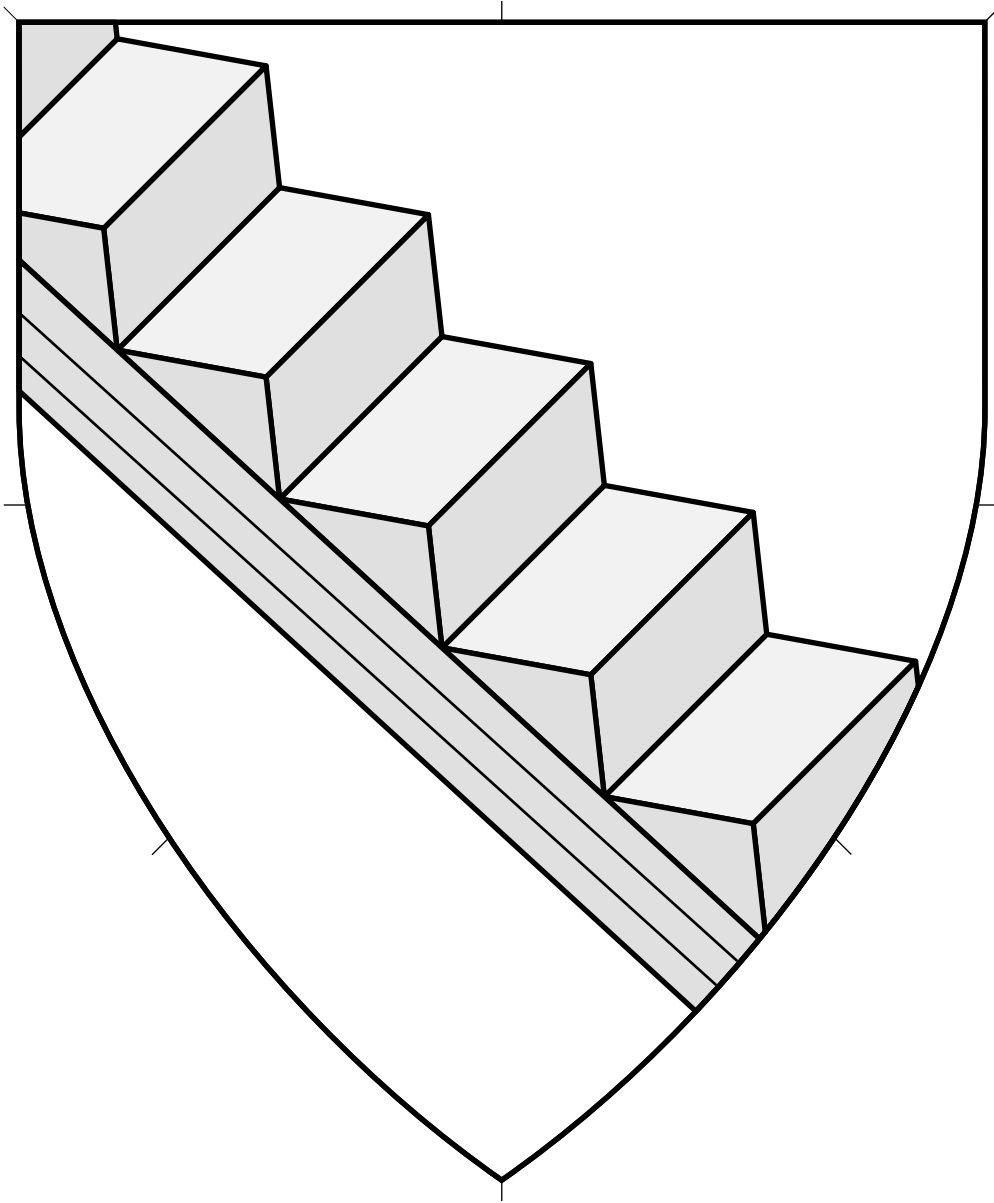

A series of steps.

Default orientation: bendwise throughout. No proper coloration.

Source: Insignia Venetorum Nobilium II. Artist unknown.
(From the arms of Gradallon, folio 177.)

Staircase 17.172

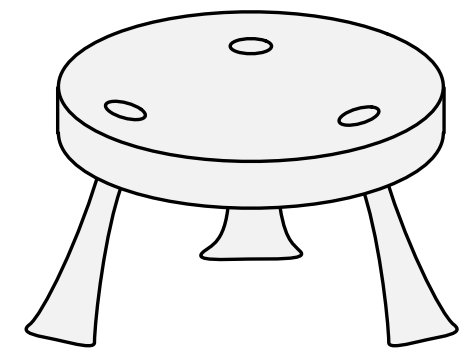
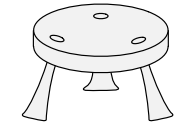
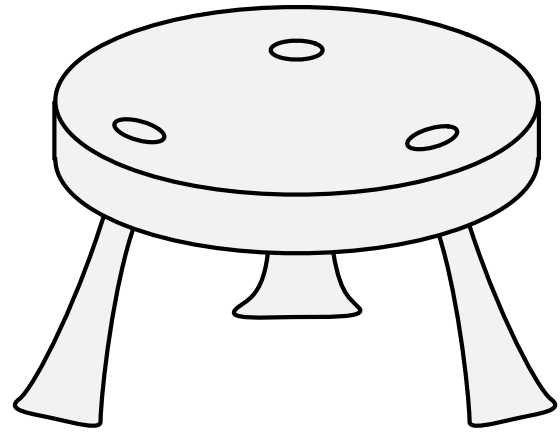
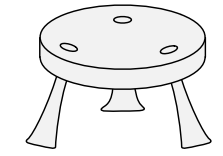
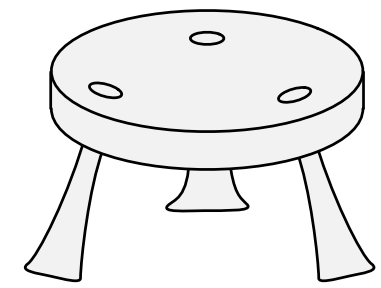
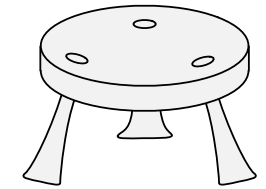
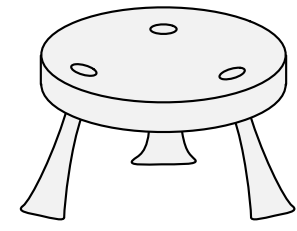
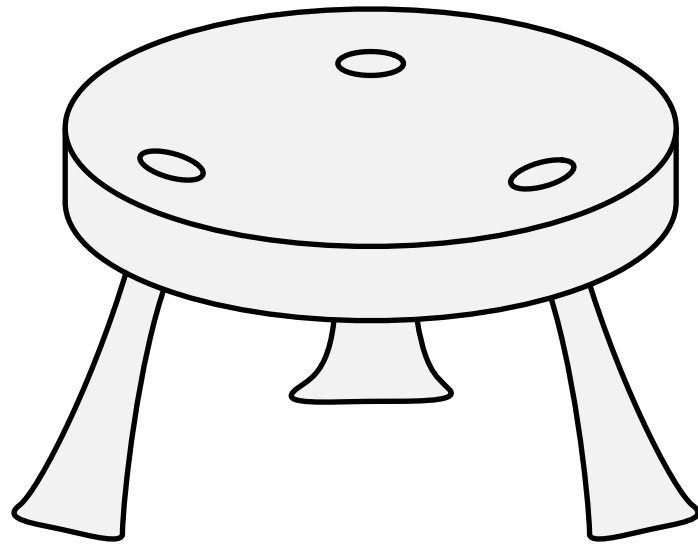

A backless chair.

Default orientation: legs to base. Proper coloration: brown wood.

Source: Insignia Urbium Italiae Septentrionalis. Artist: Unknown.
(Found in the arms of Porta Tesie S.A.)

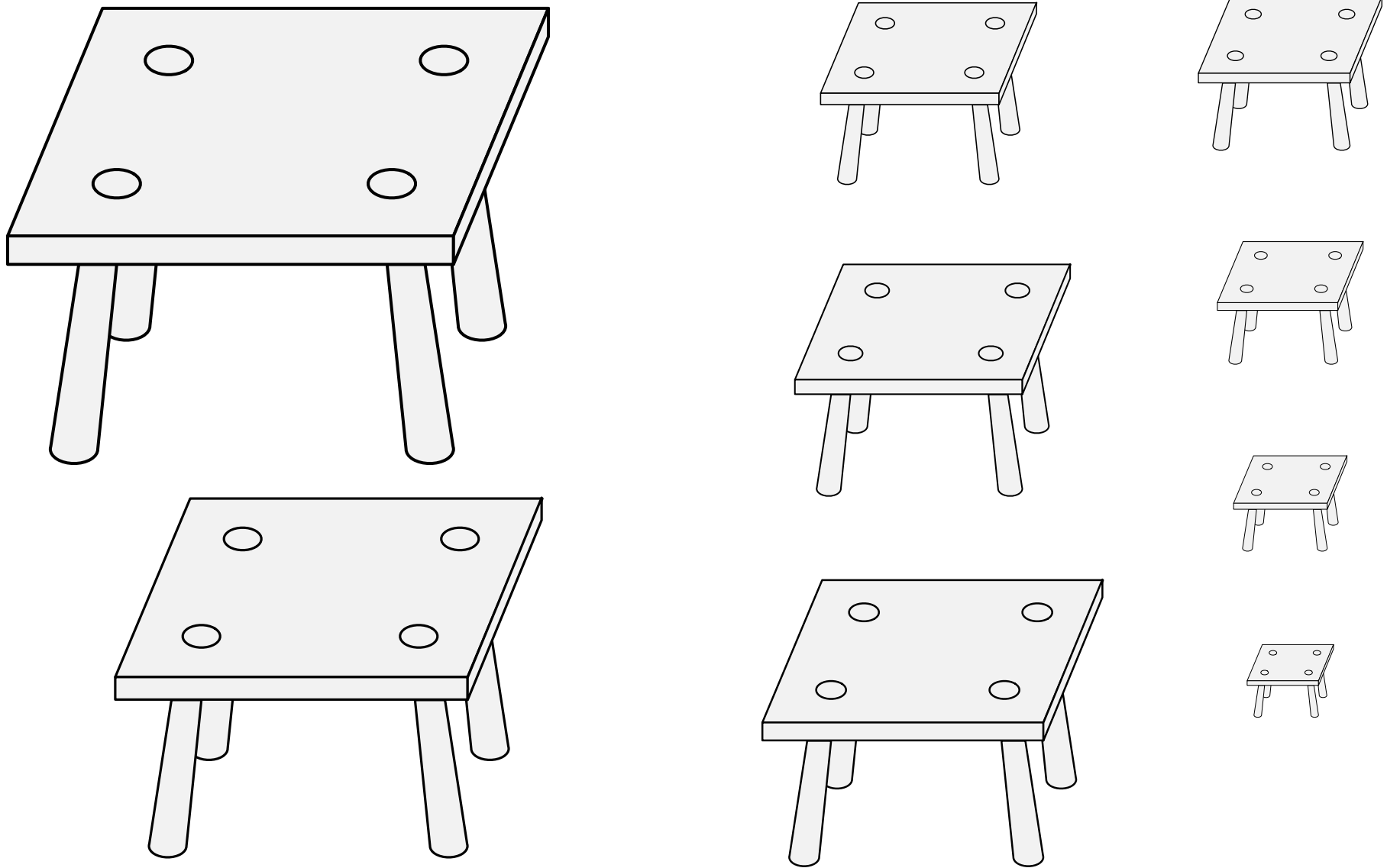

A raised surface for dining and working.

Default orientation: legs to base. Proper coloration: brown wood.

Source: Wappenbuch Süddeutschland. Artist unknown. (Folio 232v, arms of von Stillingenn.)

Table (1) 17.174

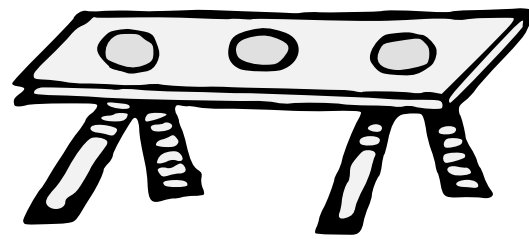
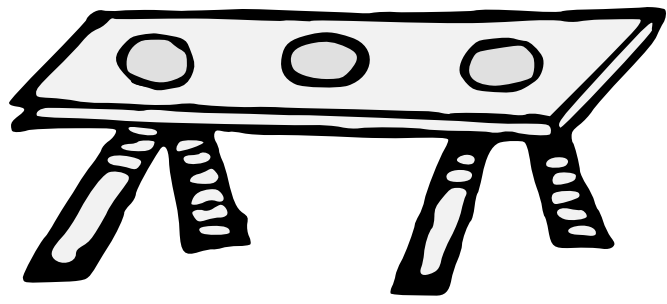
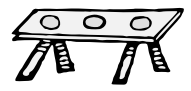
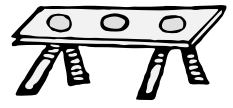
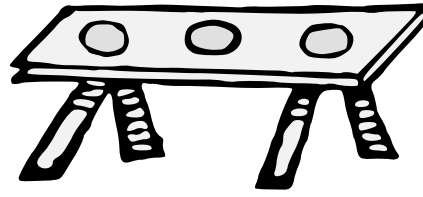
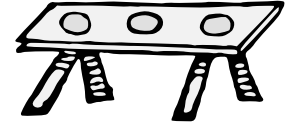
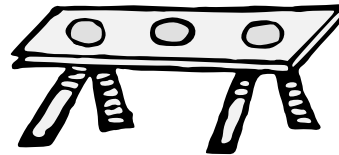
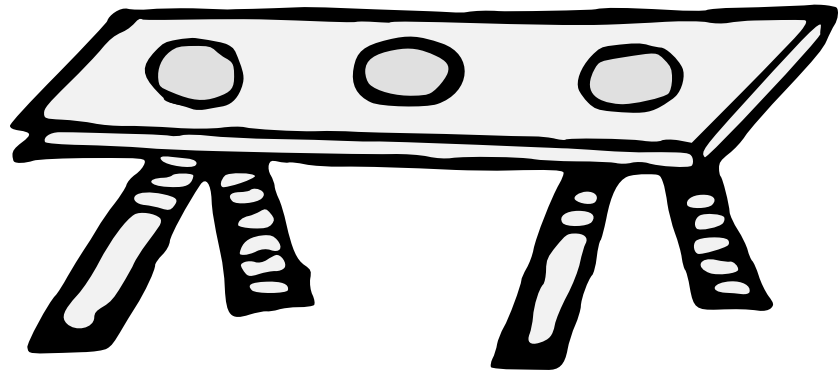

A raised surface for dining and working.
Default orientation: legs to base. Proper coloration: brown wood.
Source: Nobleza del Andaluzia. Artist unknown. (Arms of Mesa, folio 68.)

Table (2) 17.175

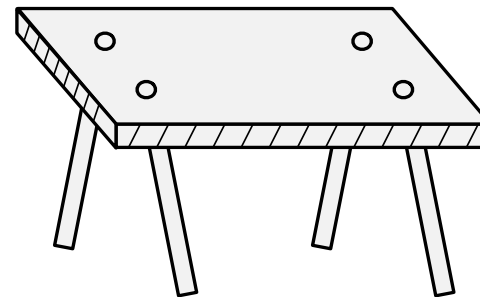
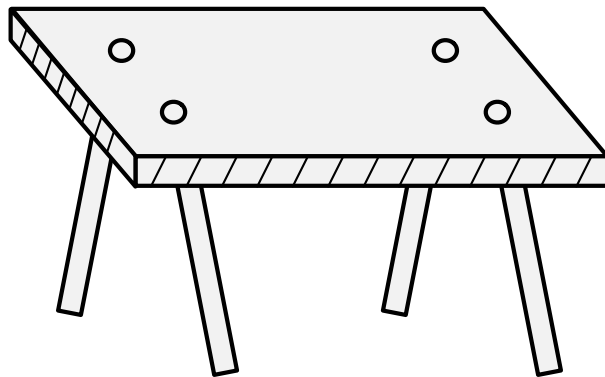
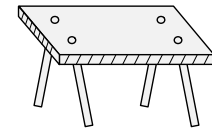
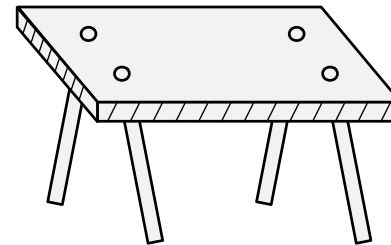
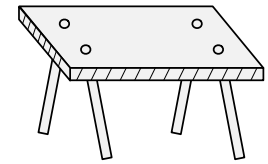
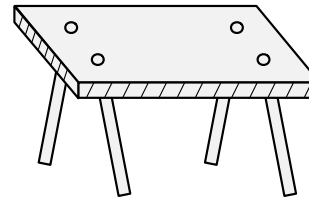
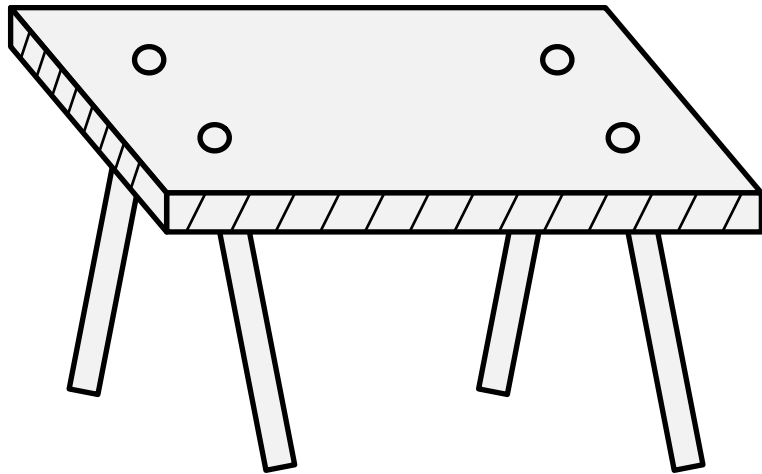

A raised surface for dining and working.

Default orientation: legs to base. Proper coloration: brown wood.

Source: BSB Cgm 8030. Artist unknown. (Folio 348v.)

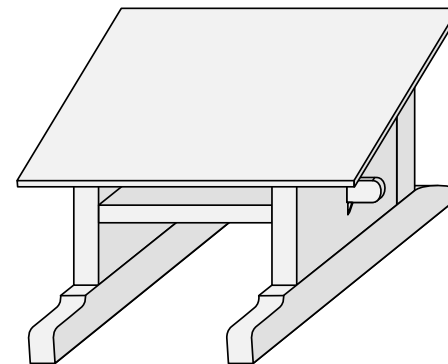
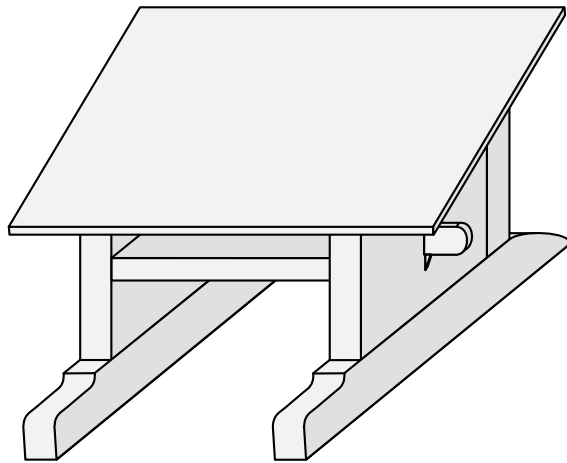
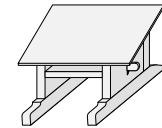
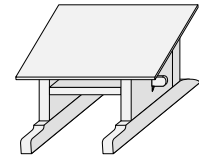
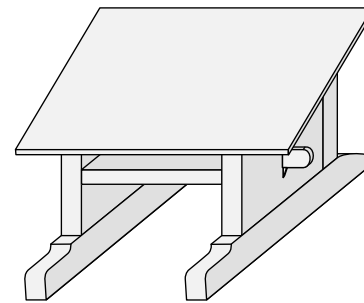
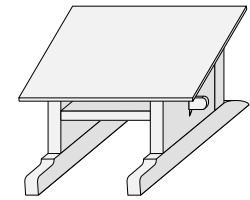
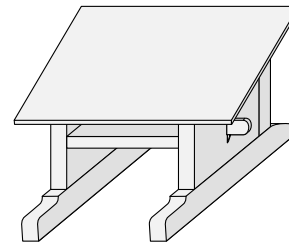
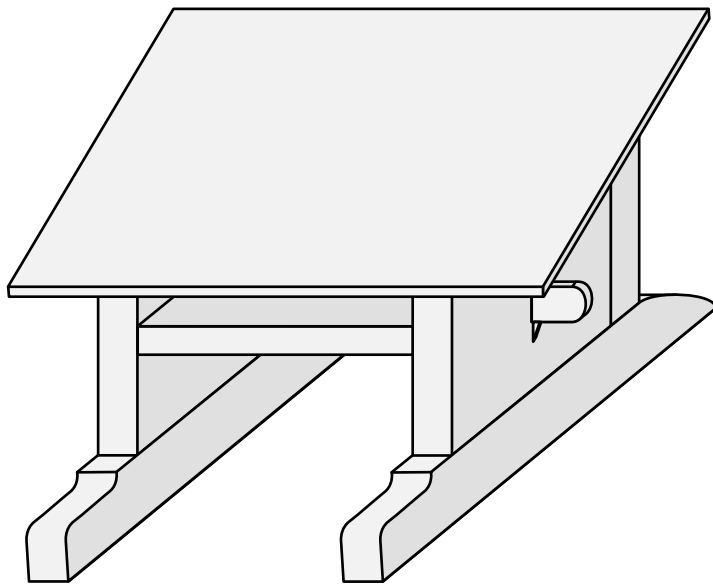

A table with a slanted surface used for scribal work.

Default orientation: legs to base. Proper coloration: brown wood.

Source: Wappenstambuch - Cod. Karlsruhe 2821. (Page 149.)

Artist unknown. Adapted by Mathghamhain Ua Ruadháin.

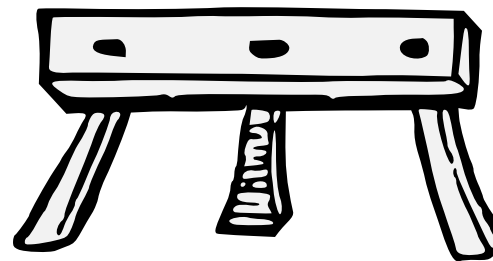
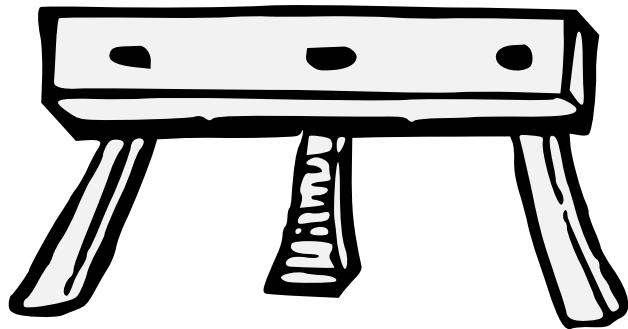
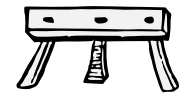
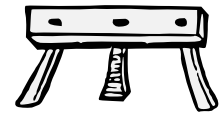
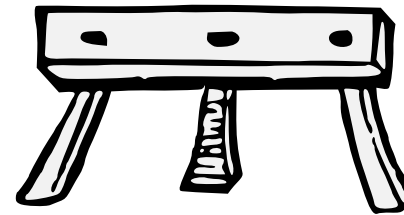
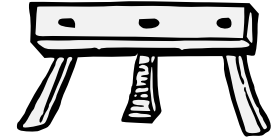
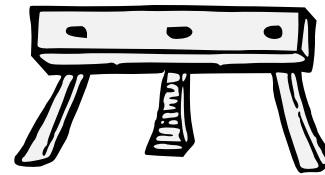
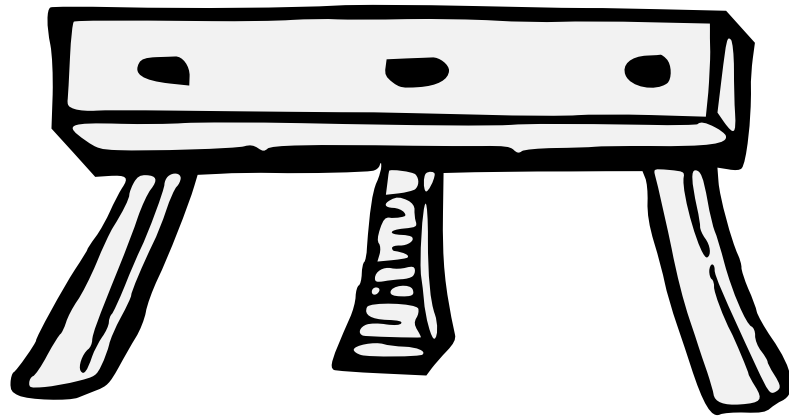

A portable structure similar to a modern sawhorse, used to support a table top for a feast.

Default orientation: fesswise, legs to base. No proper coloration.

Source: Guillim's Display of Heraldry. Artist unknown.

Table-Trestle 17.178

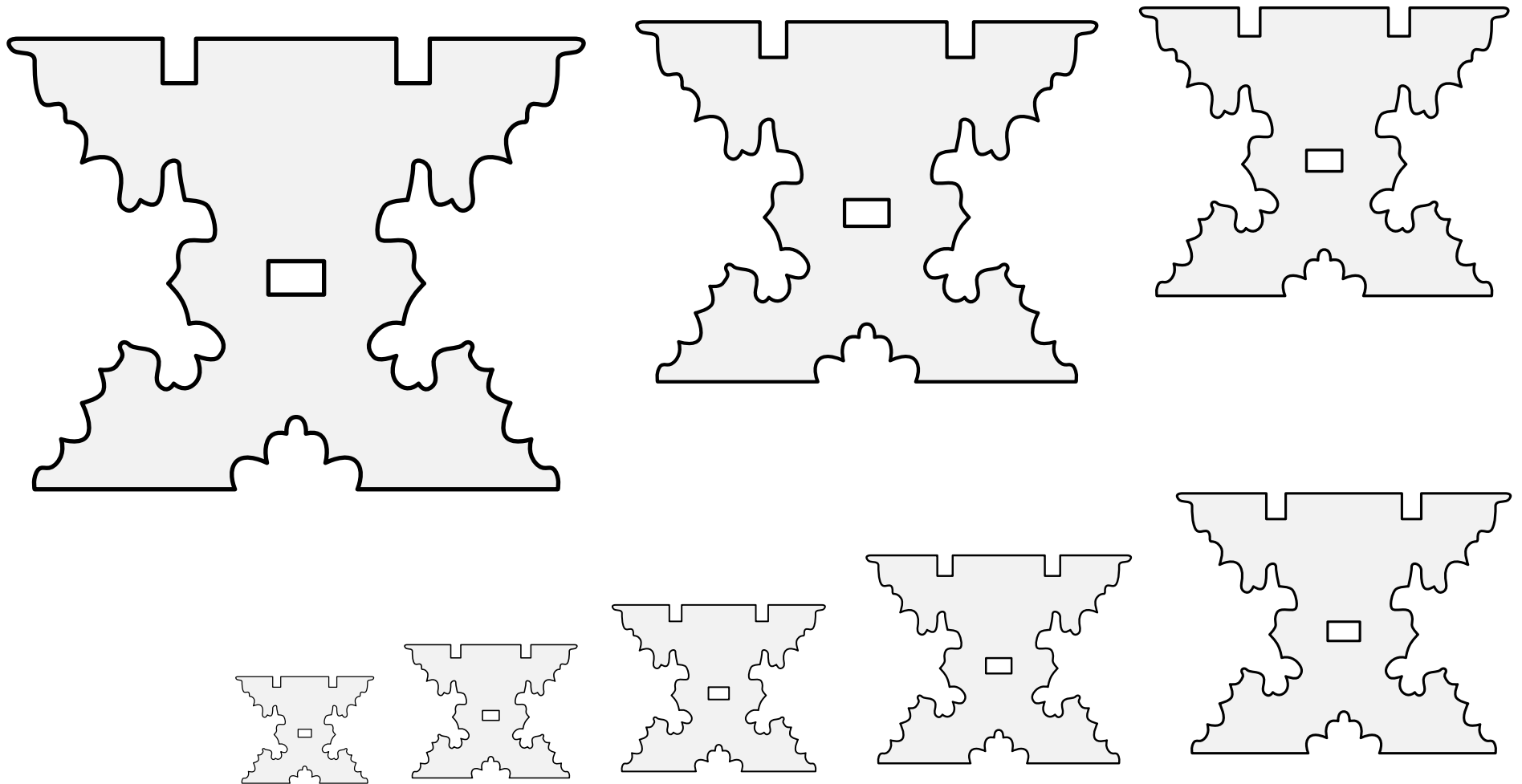

A portable structure used to support a table top for a feast.

Default orientation: fesswise, legs to base. No proper coloration.

This charge is blazoned by Rietstap as an "antique table with a single foot, viewed in profile."

Source: Siebmacher's Wappenbuch of 1605.

Artist: Johann Siebmacher.

(Arms of Marschalck von Ostheim, page 101.)



A ceremonial gate as might be found in front of a Japanese shrine.

Default orientation: upright. No proper coloration.

Found in Japanese armory, but not in European, and thus a Step From Core Practice (SFCP).

Source: O-umajirushi. Artist: Kyūan. Adapted by Mathghamhain Ua Ruadháin.

Torii (1) 17.180

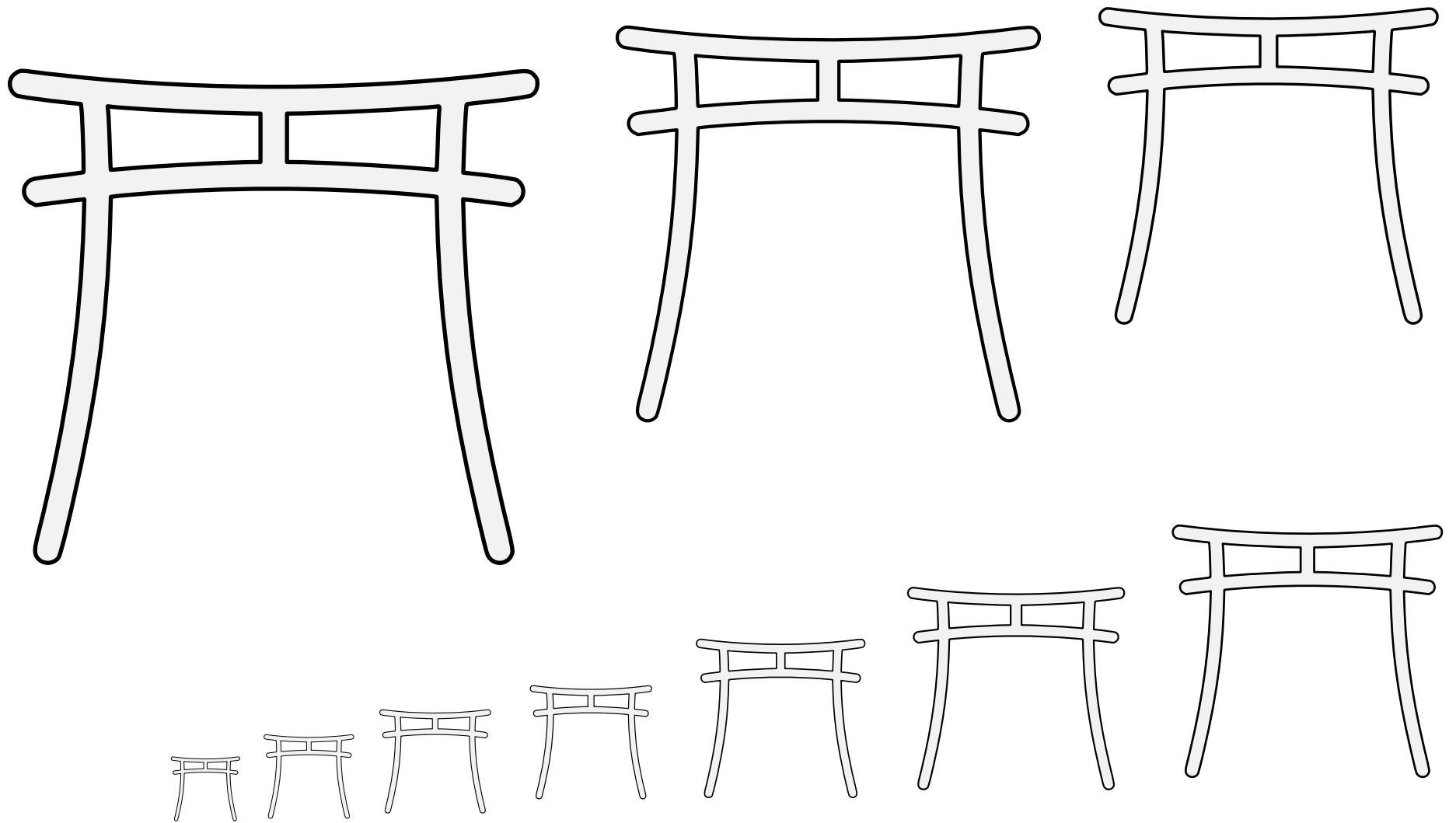

A ceremonial gate as might be found in front of a Japanese shrine.

Default orientation: upright. No proper coloration.

Found in Japanese armory, but not in European, and thus a Step From Core Practice (SFCP).

Source: SVG Heraldry Components. Artist: Nicholas de Estleche.

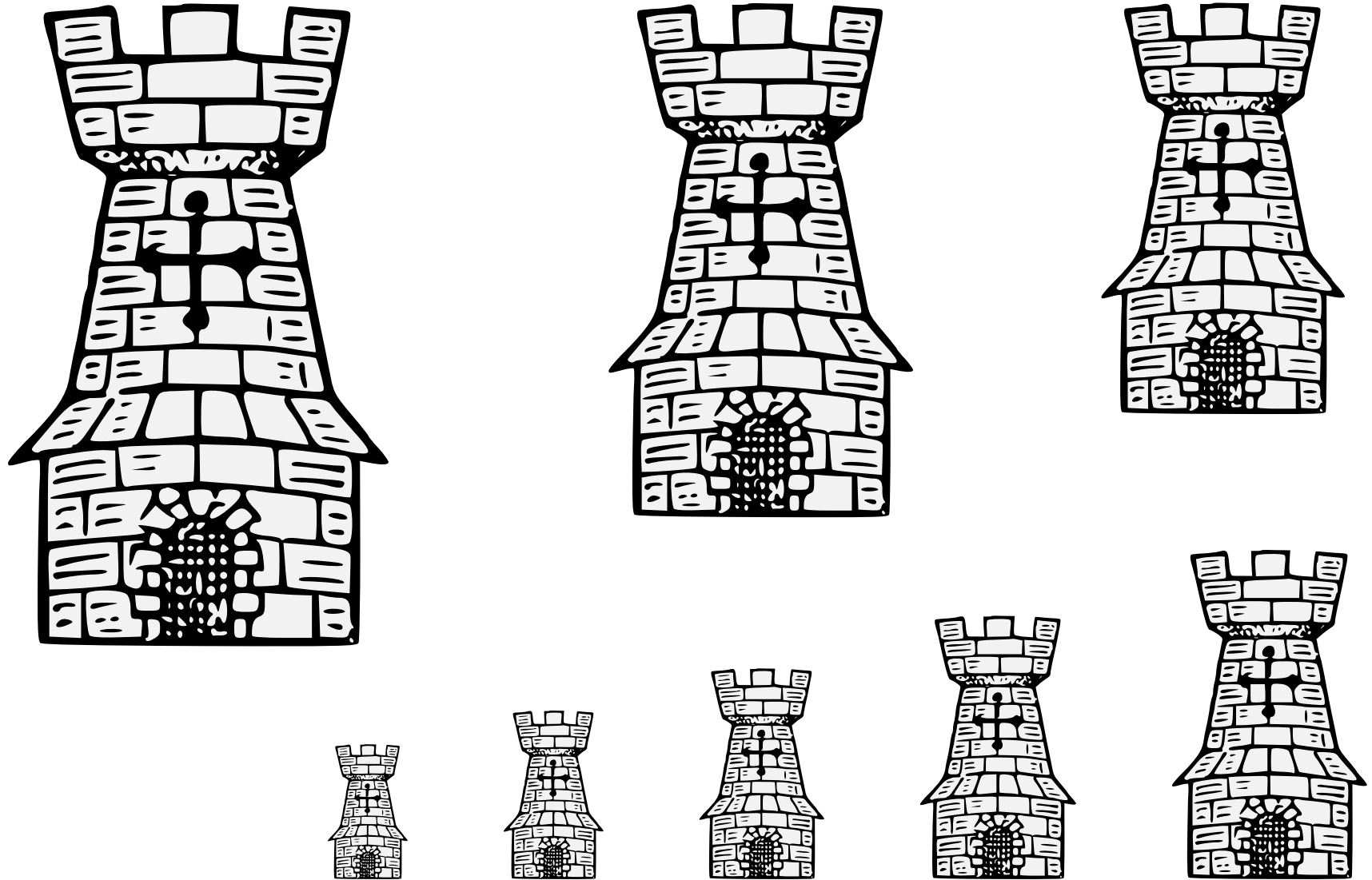

A circular or square stone building as might be found in a castle.
Default orientation: palewise. Proper coloration: argent or gray.
Source: A Complete Guide to Heraldry. Artist: Graham Johnston.

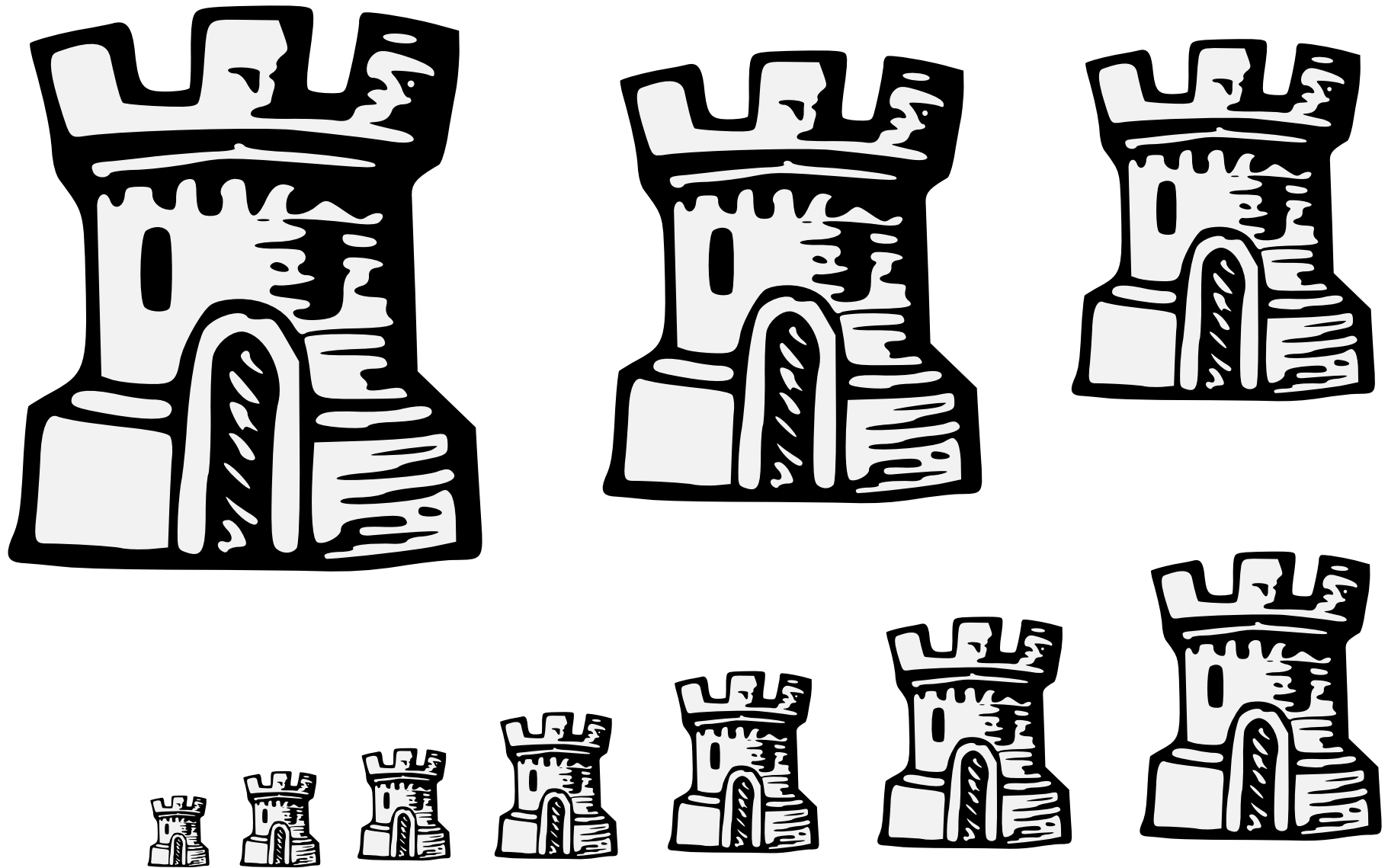

A circular or square stone building as might be found in a castle.
Default orientation: palewise. Proper coloration: argent or gray.
Source: Guillim's Display of Heraldry. Artist unknown.

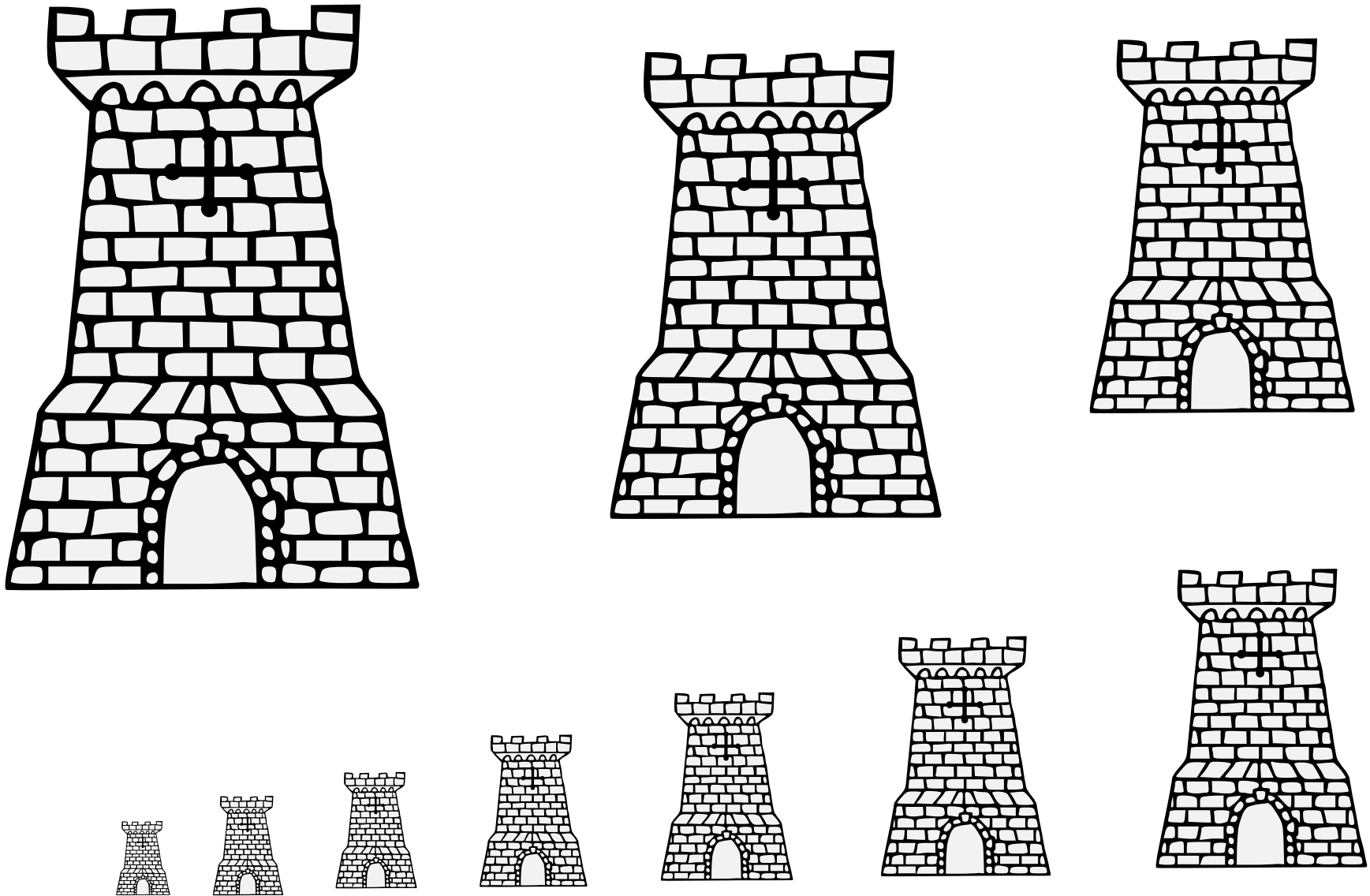

A circular or square stone building as might be found in a castle.
Default orientation: palewise. Proper coloration: argent or gray.
Source: Pennsic Traceable Art. Artist: Elsbeth Anne Roth.

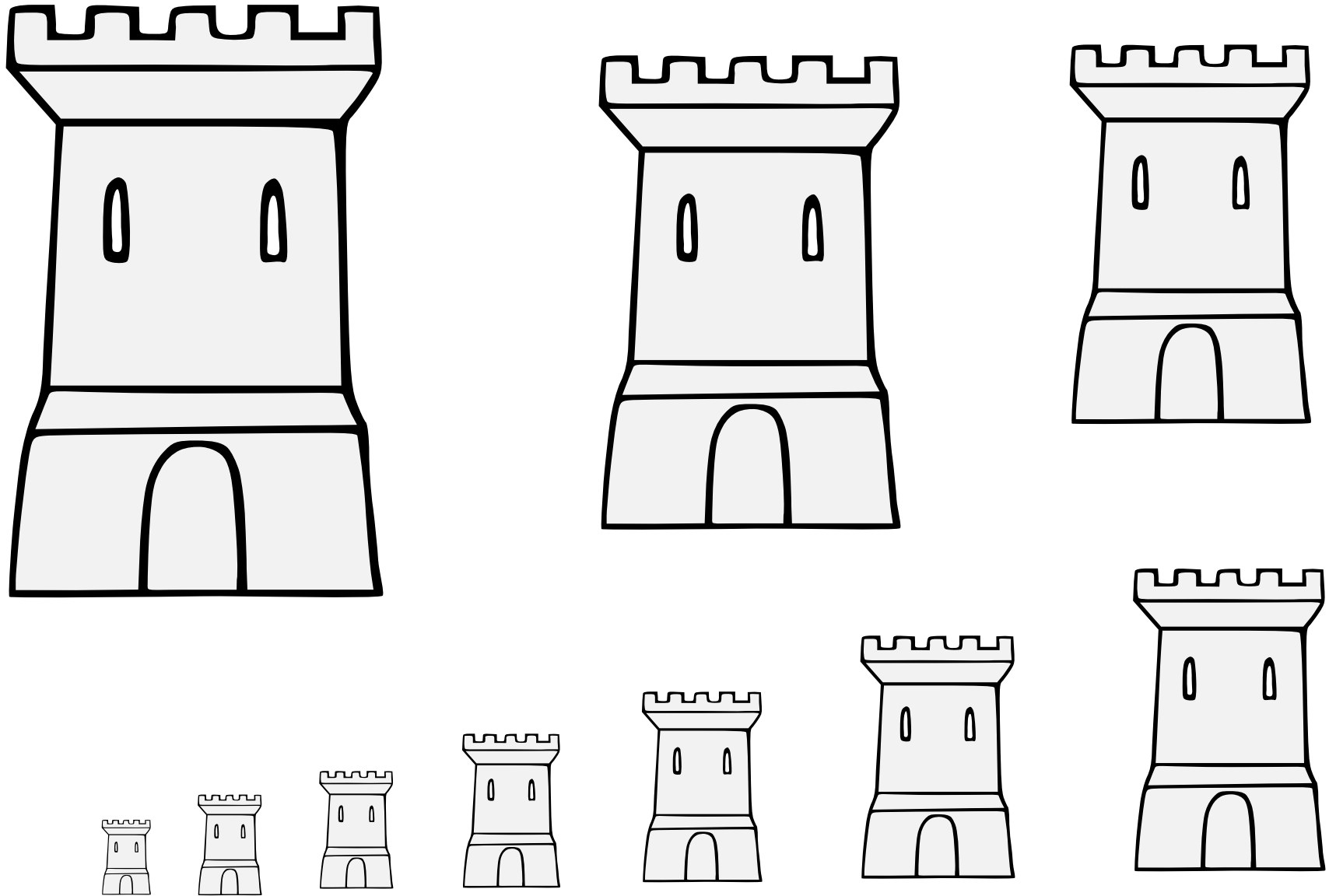

A circular or square stone building as might be found in a castle.
Default orientation: palewise. Proper coloration: argent or gray.
Source: Pennsic Traceable Art. Artist unknown.

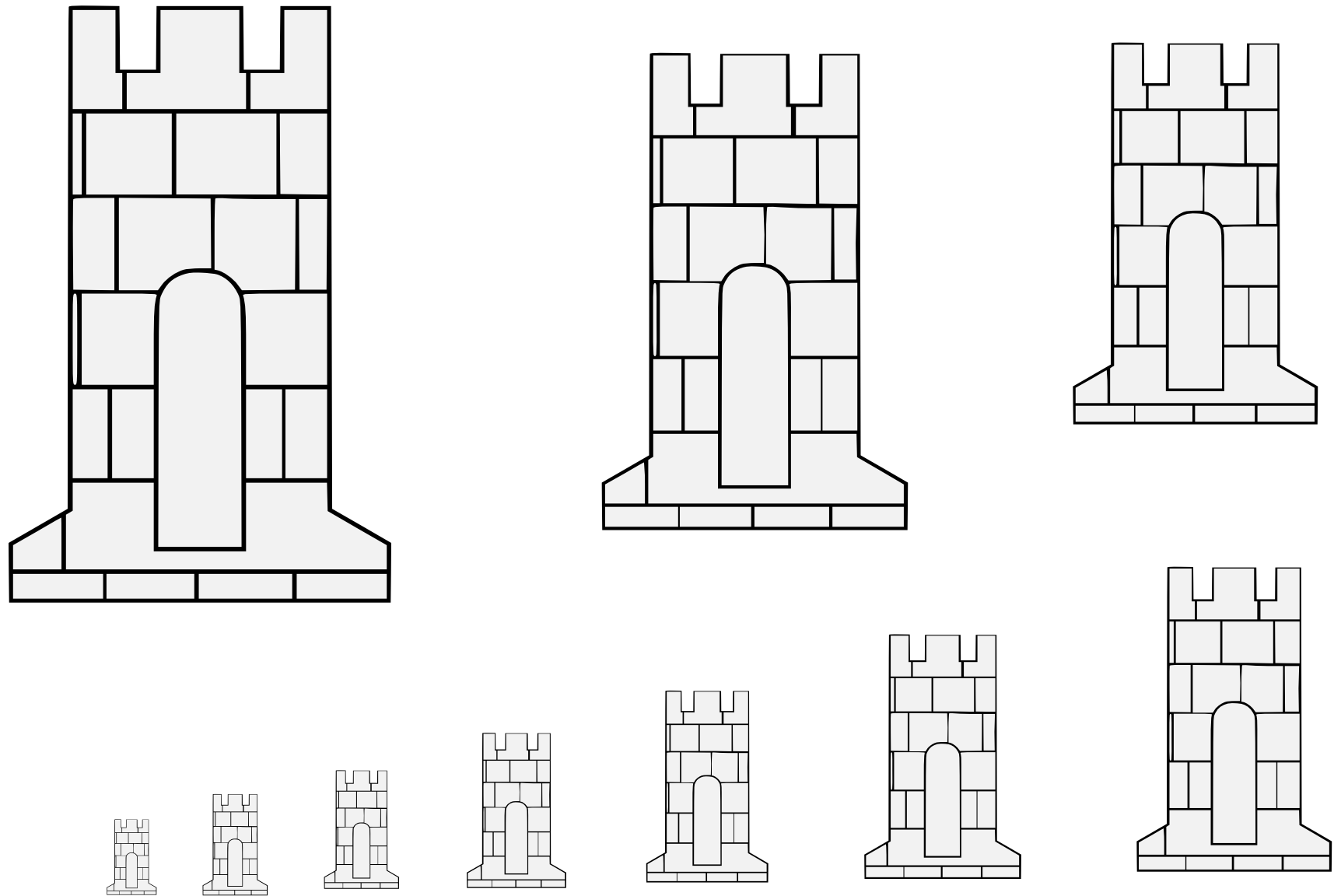

A circular or square stone building as might be found in a castle.

Default orientation: palewise. Proper coloration: argent or gray.

Artist: Jon Cheseby. Adapted from Armorial de Gilles Le Bouvier (France, 15th C.).

Tower (5) 17.186

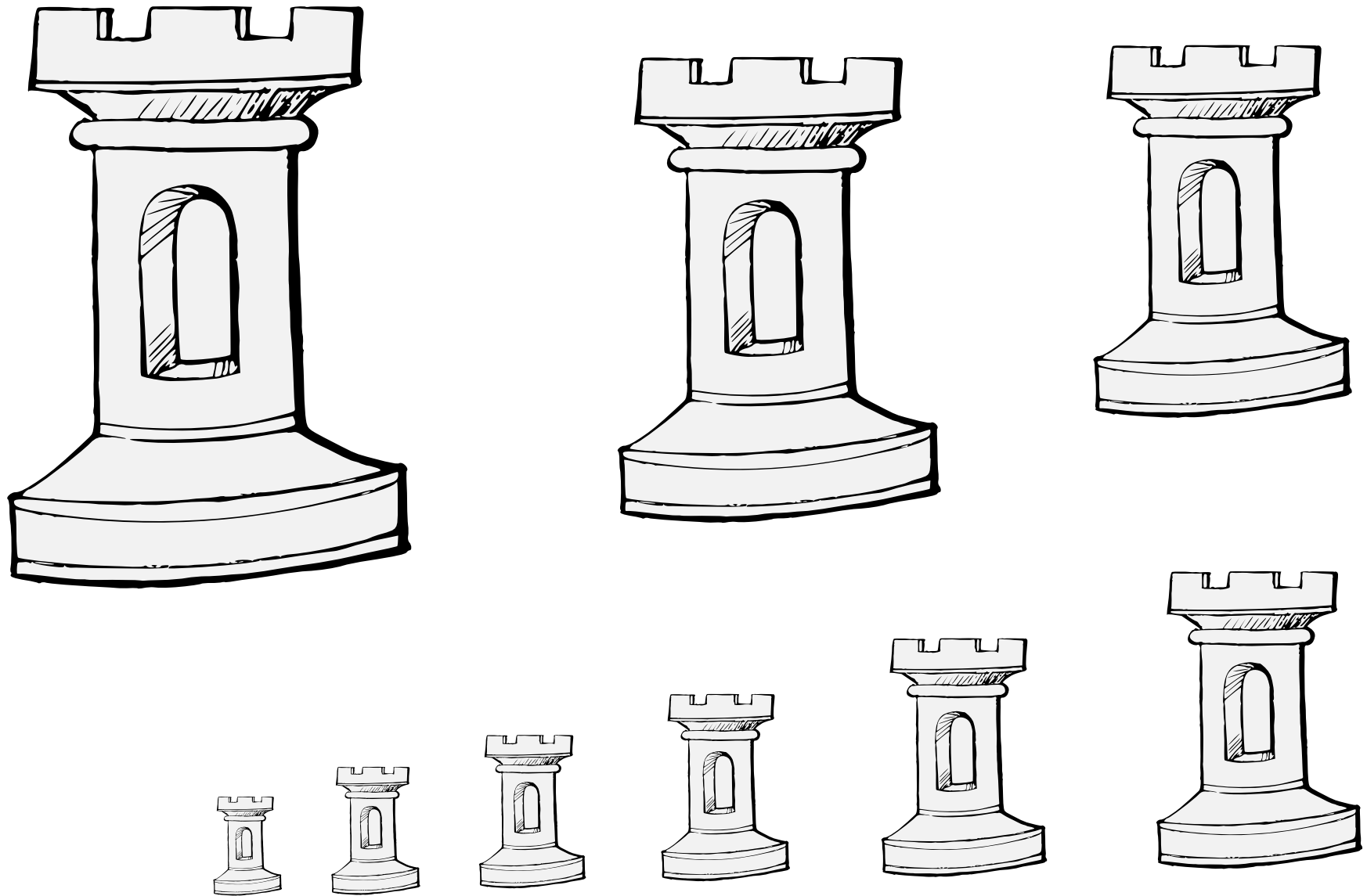

A circular or square stone building as might be found in a castle.
Default orientation: palewise. Proper coloration: argent or gray.
Source: Scheibler Armorial. Artist: Unknown. (From the arms of Waldow.)

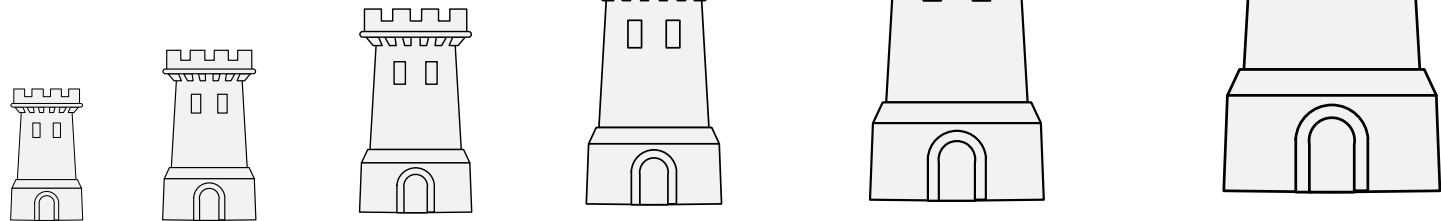
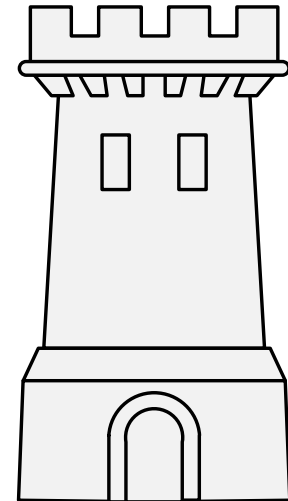
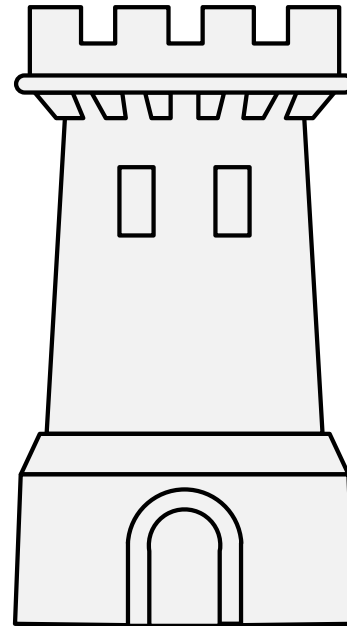
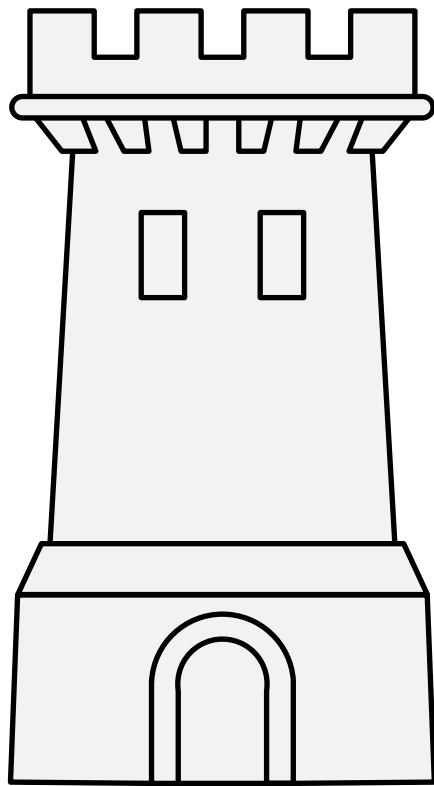

A circular or square stone building as might be found in a castle.

Default orientation: palewise. Proper coloration: argent or gray.

Source: Viking Answer Lady SVG Images For Heraldists. Artist: Gunnvôr silfráhr.

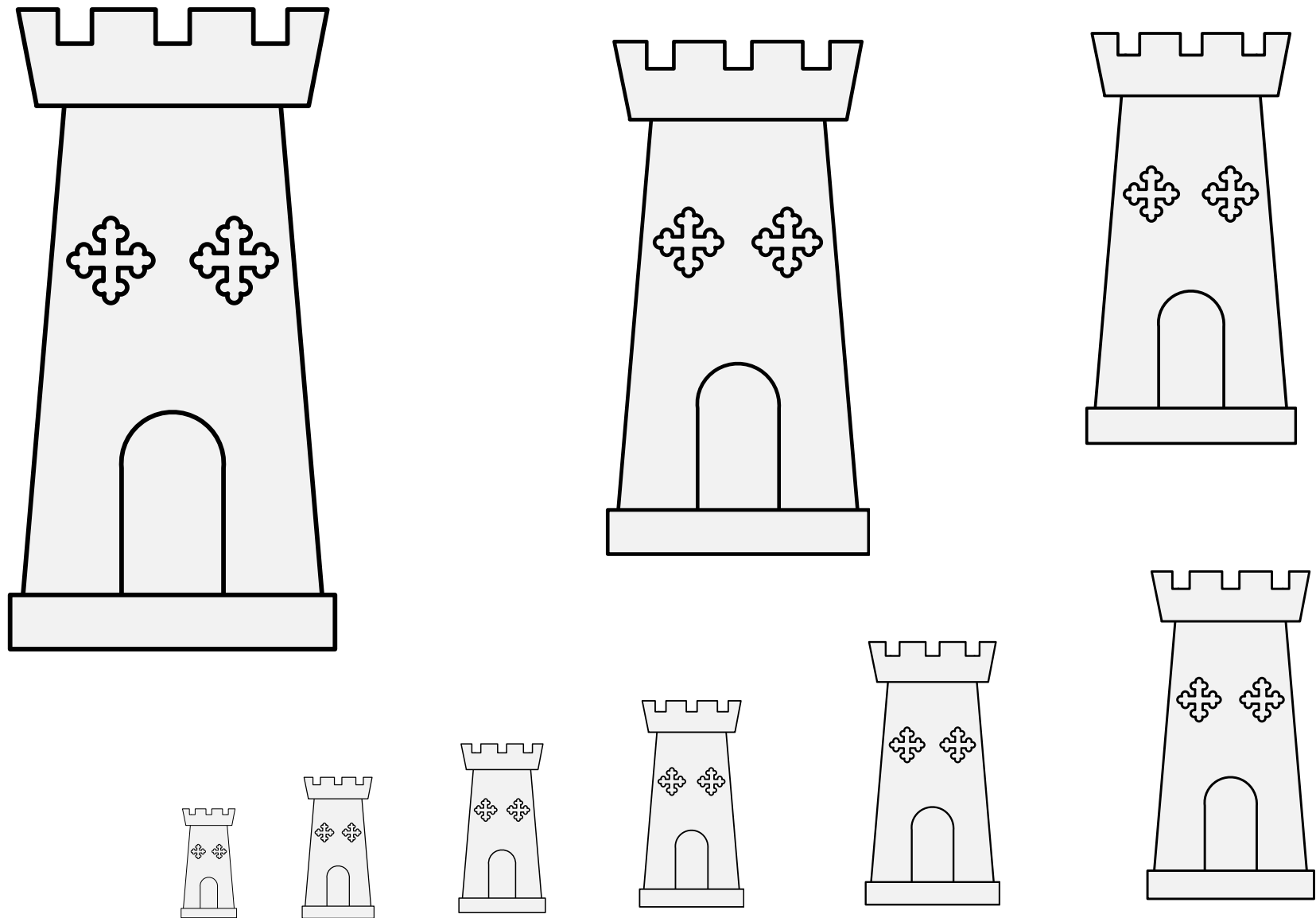

A circular or square stone building as might be found in a castle.

Default orientation: palewise. Proper coloration: argent or gray.

Source: Viking Answer Lady SVG Images For Heraldists. Artist: Gunnvôr silfráhr.

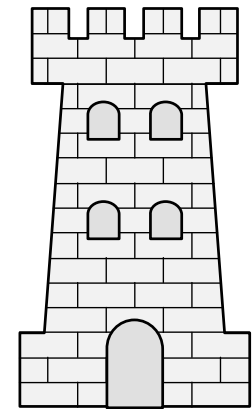
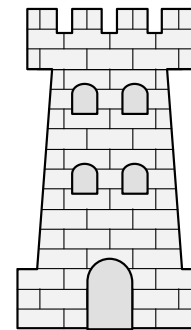
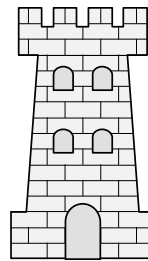
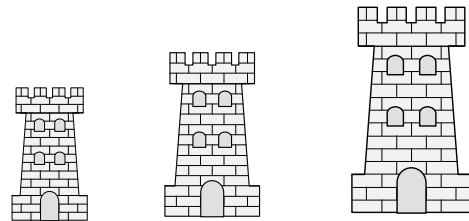
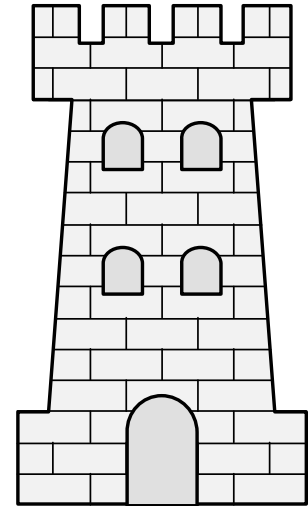
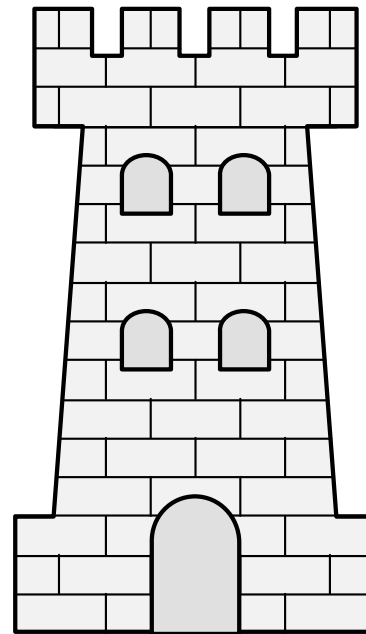
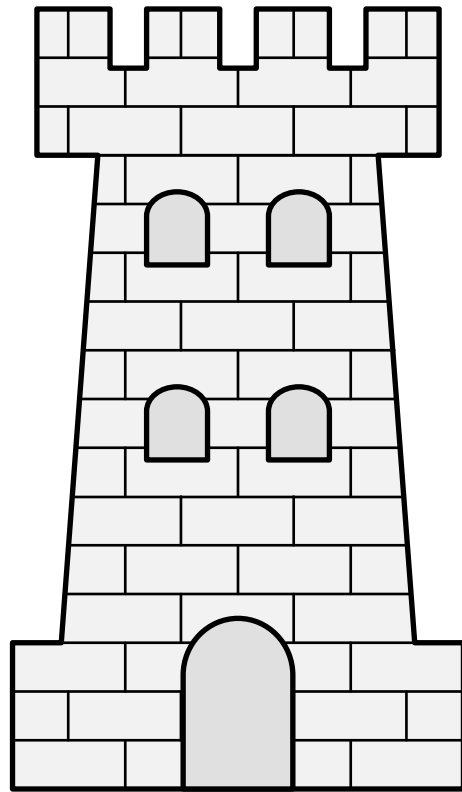

A circular or square stone building as might be found in a castle.
Default orientation: palewise. Proper coloration: argent or gray.

Tower (9) 17.190

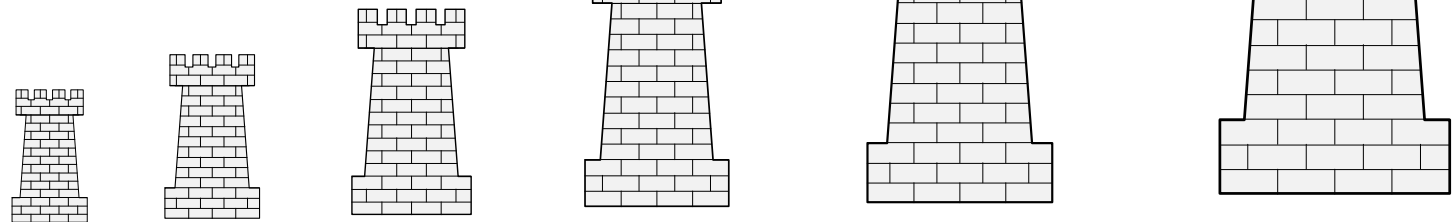
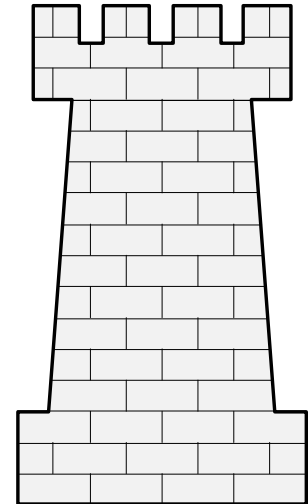
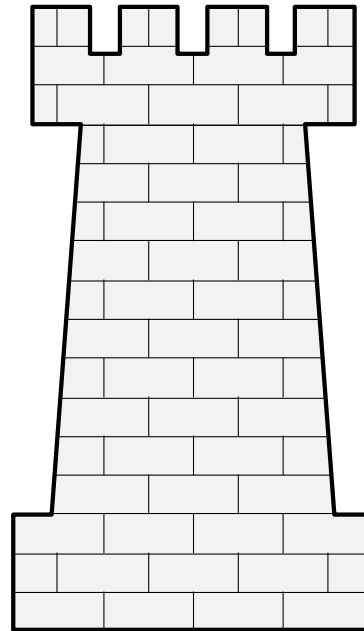
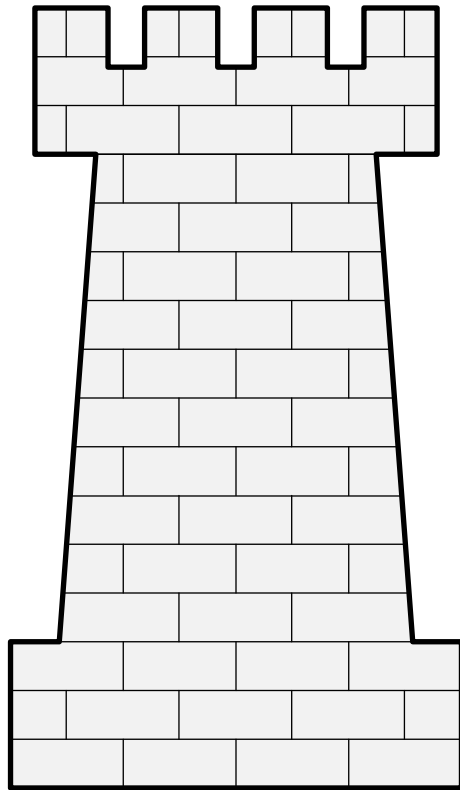

A circular or square stone building as might be found in a castle.
Default orientation: palewise. Proper coloration: argent or gray.

Tower (10) 17.191

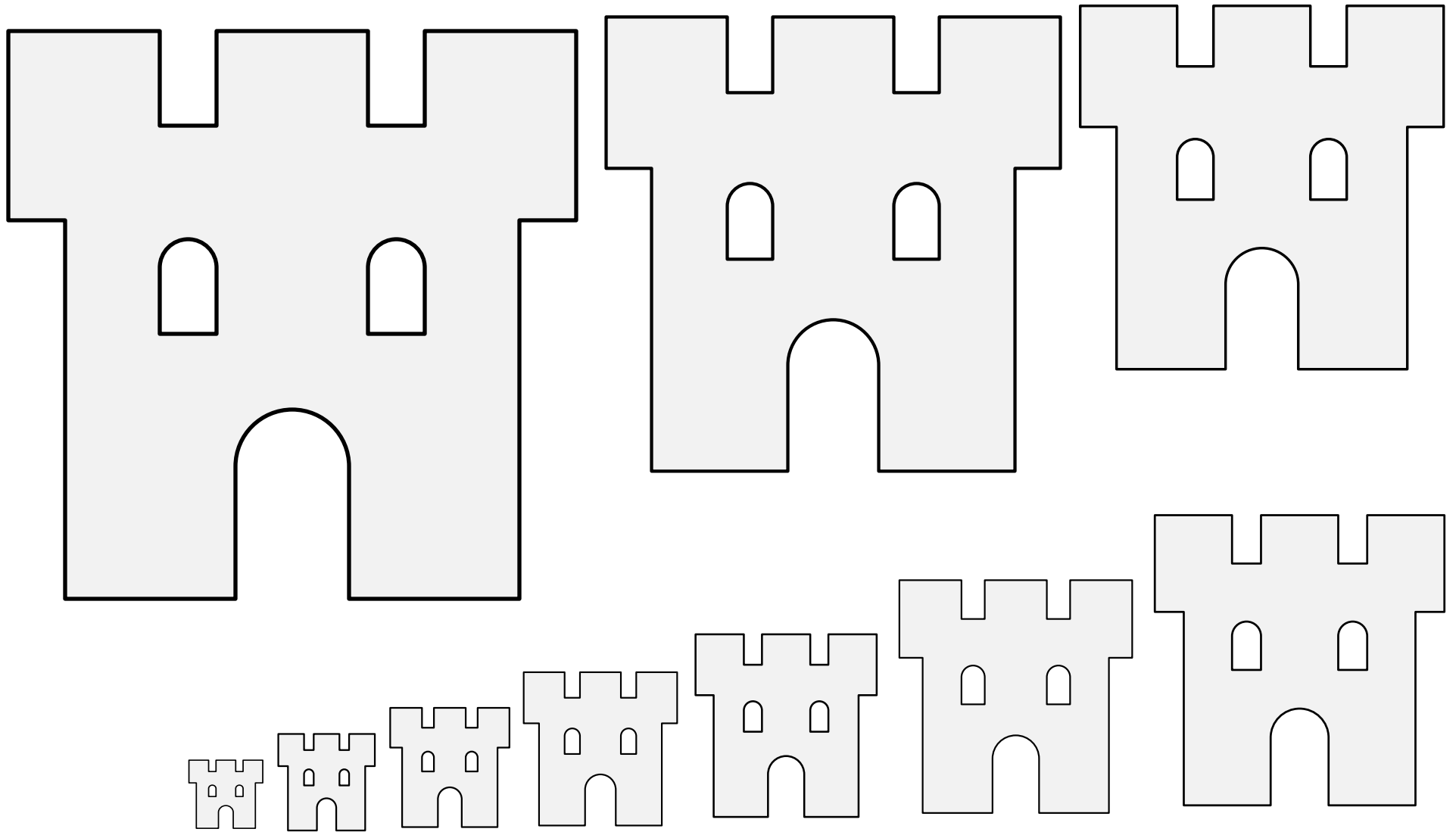

A circular or square stone building as might be found in a castle.

Default orientation: palewise. Proper coloration: argent or gray.

Artist: Mathghamhain Ua Ruadháin.

Tower (11) 17.192

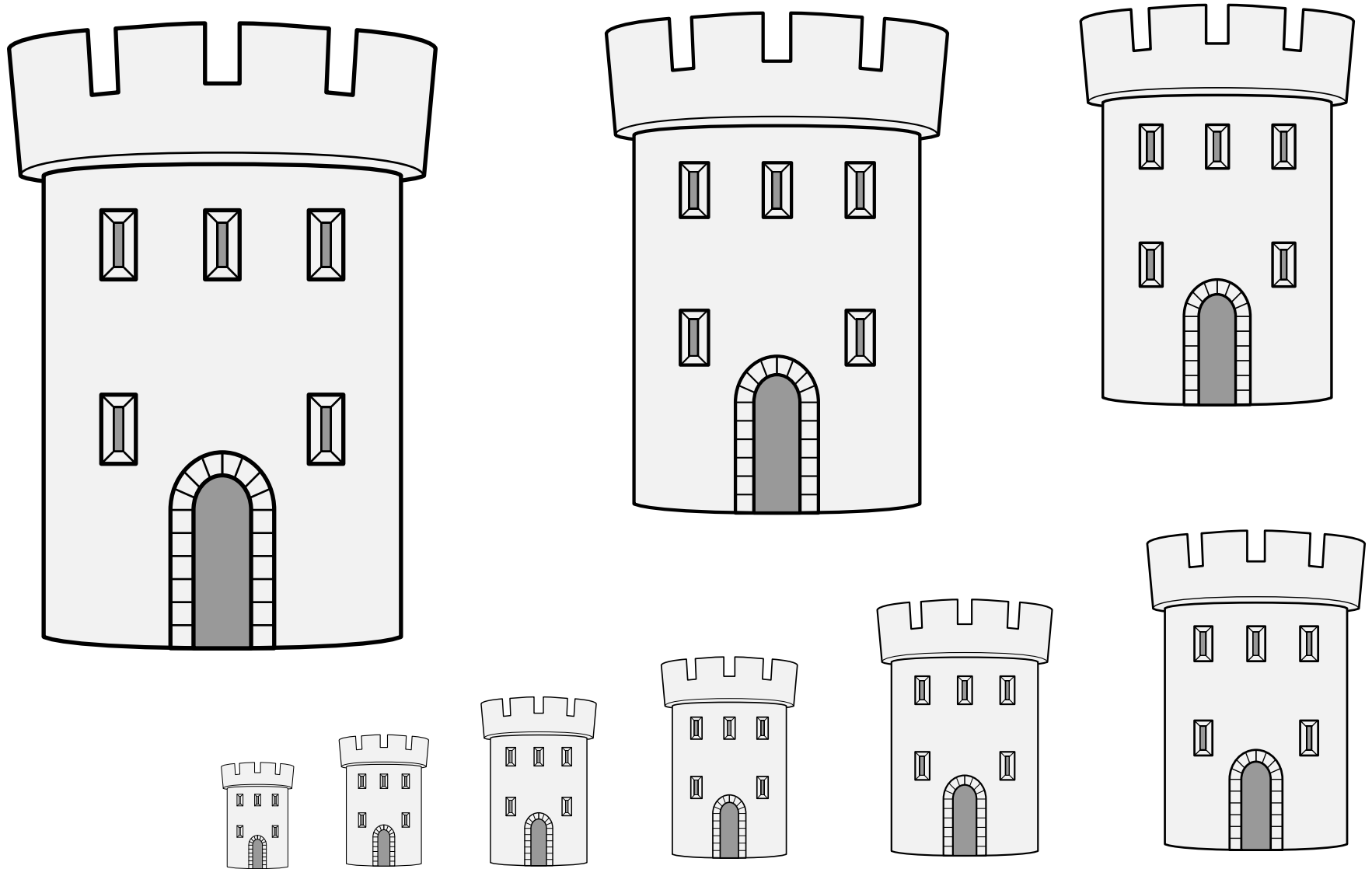

A circular or square stone building as might be found in a castle.

Default orientation: palewise. Proper coloration: argent or gray.

Source: Opus Insignium Armorumque. Artist: Johann Weikhard von Valvasor.
Adapted by Mathghamhain Ua Ruadháin.

Tower (12) 17.193

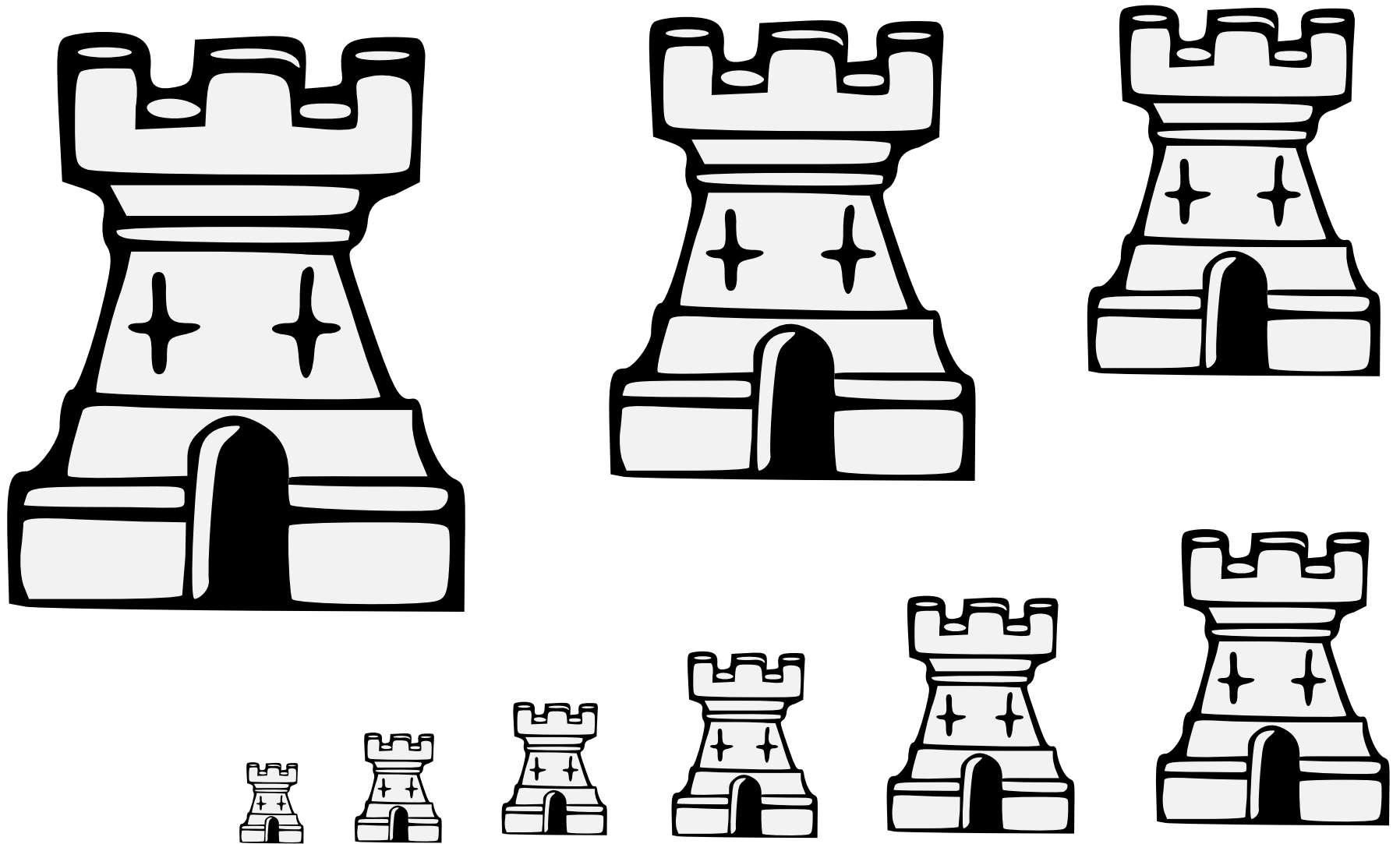

A circular or square stone building as might be found in a castle.

Default orientation: palewise. Proper coloration: argent or gray.

Source: Two Tudor Books of Arms. Artist: Robert Cooke.
(From page 150, arms of John Dunstall.)

Tower (13) 17.194

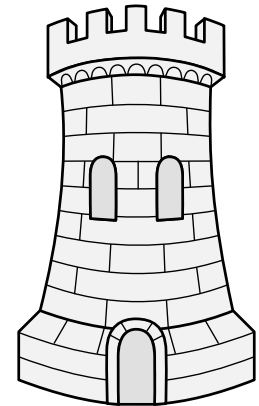
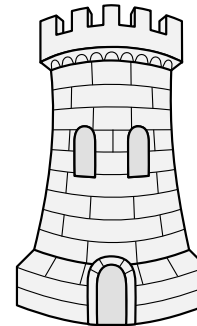
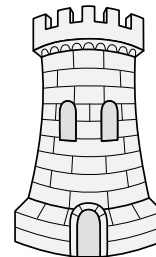
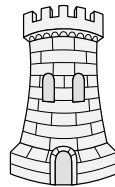
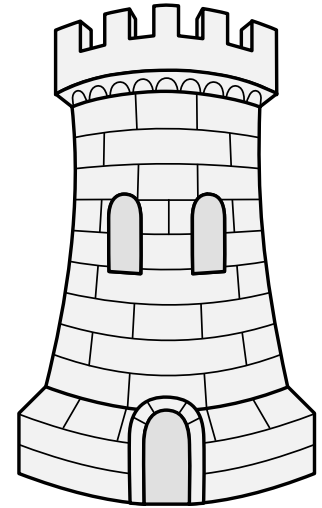
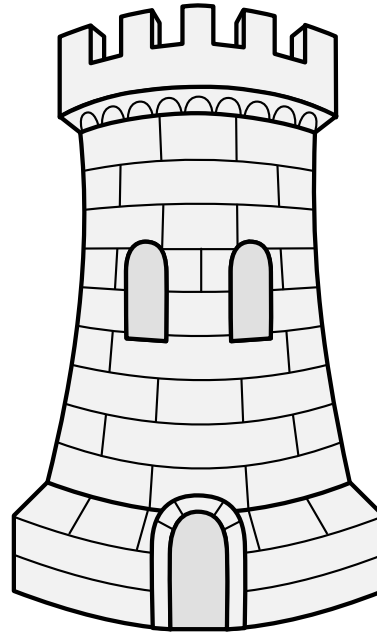
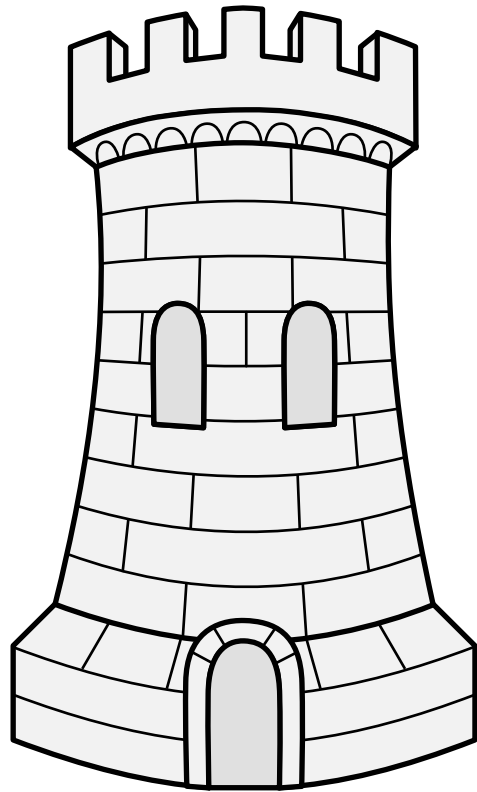

A circular or square stone building as might be found in a castle.
Default orientation: palewise. Proper coloration: argent or gray.
Source: SVG Heraldry Components. Artist: Nicholas de Estleche.

Tower (14) 17.195

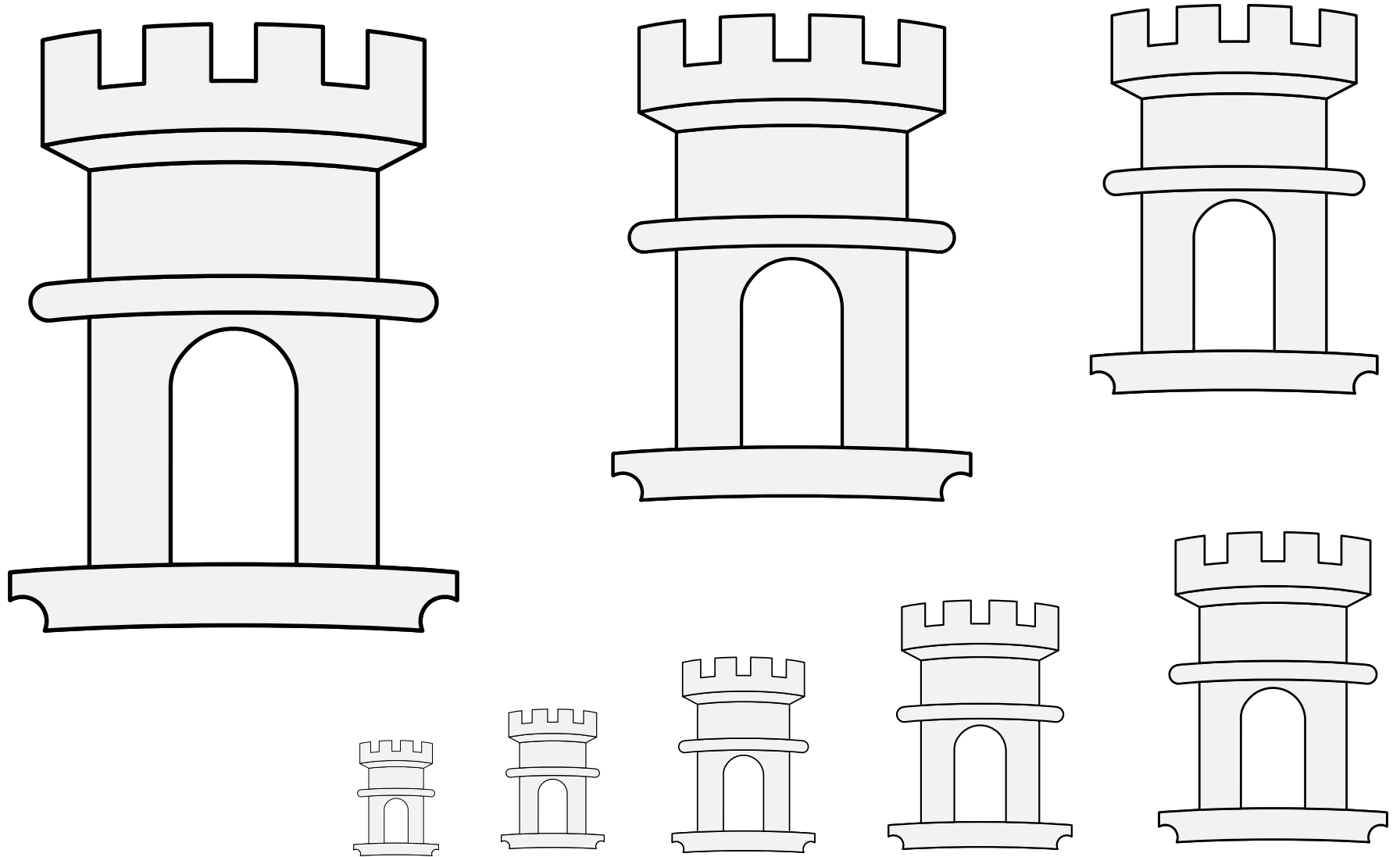

A circular or square stone building as might be found in a castle.

Default orientation: palewise. Proper coloration: argent or gray.

Source: Wappenbuch der Arlberg-Bruderschaft.

Artist: Vigil Raber. (Page 18.)

Tower (15) 17.196

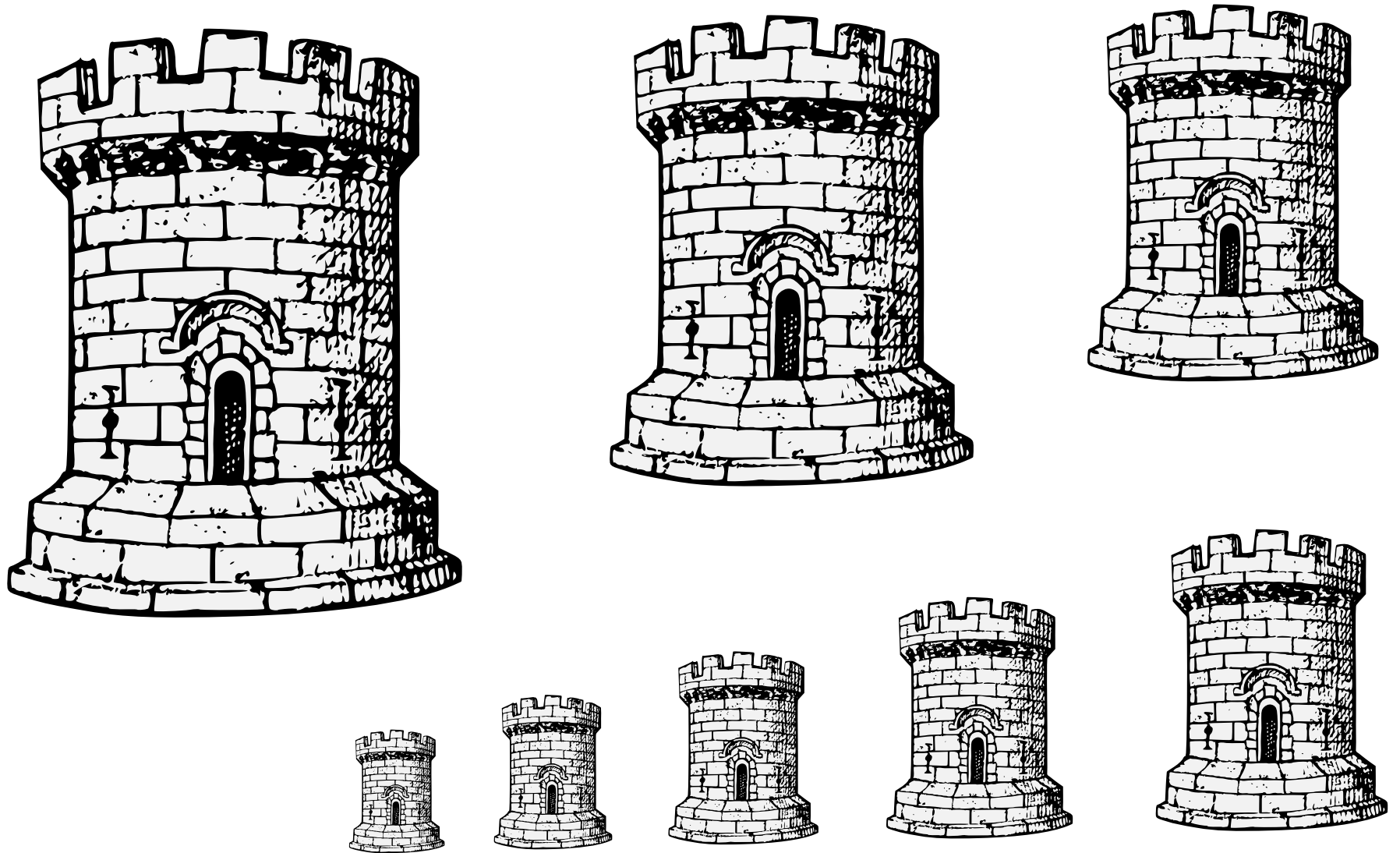

A circular or square stone building as might be found in a castle.
Default orientation: palewise. Proper coloration: argent or gray.
Source: Livro do Armeiro-Mor. Artist: Jean Du Cros. (Folio 70v.)

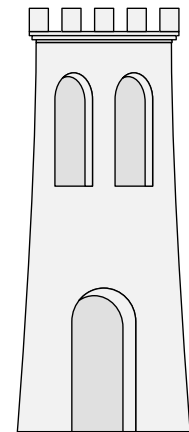
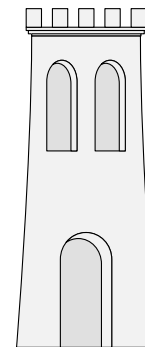
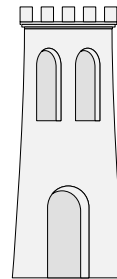
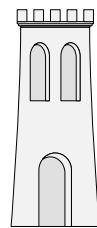
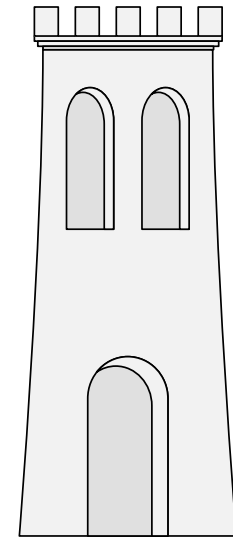
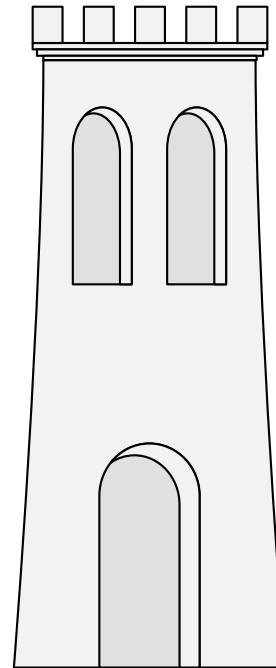
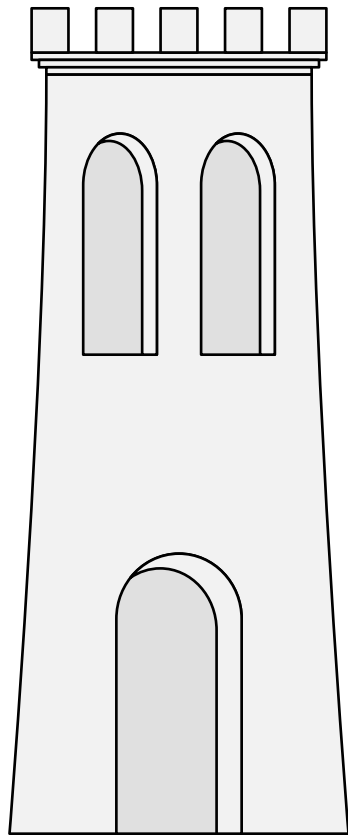

A circular or square stone building as might be found in a castle.

Default orientation: palewise. Proper coloration: argent or gray.

Source: *Insignia Urbium Italiae Septentrionalis*. Artist: Unknown.
(Arms of de Branbano, folio 81r.) Adapted by Mathghamhain Ua Ruadháin.

Tower (17) 17.198

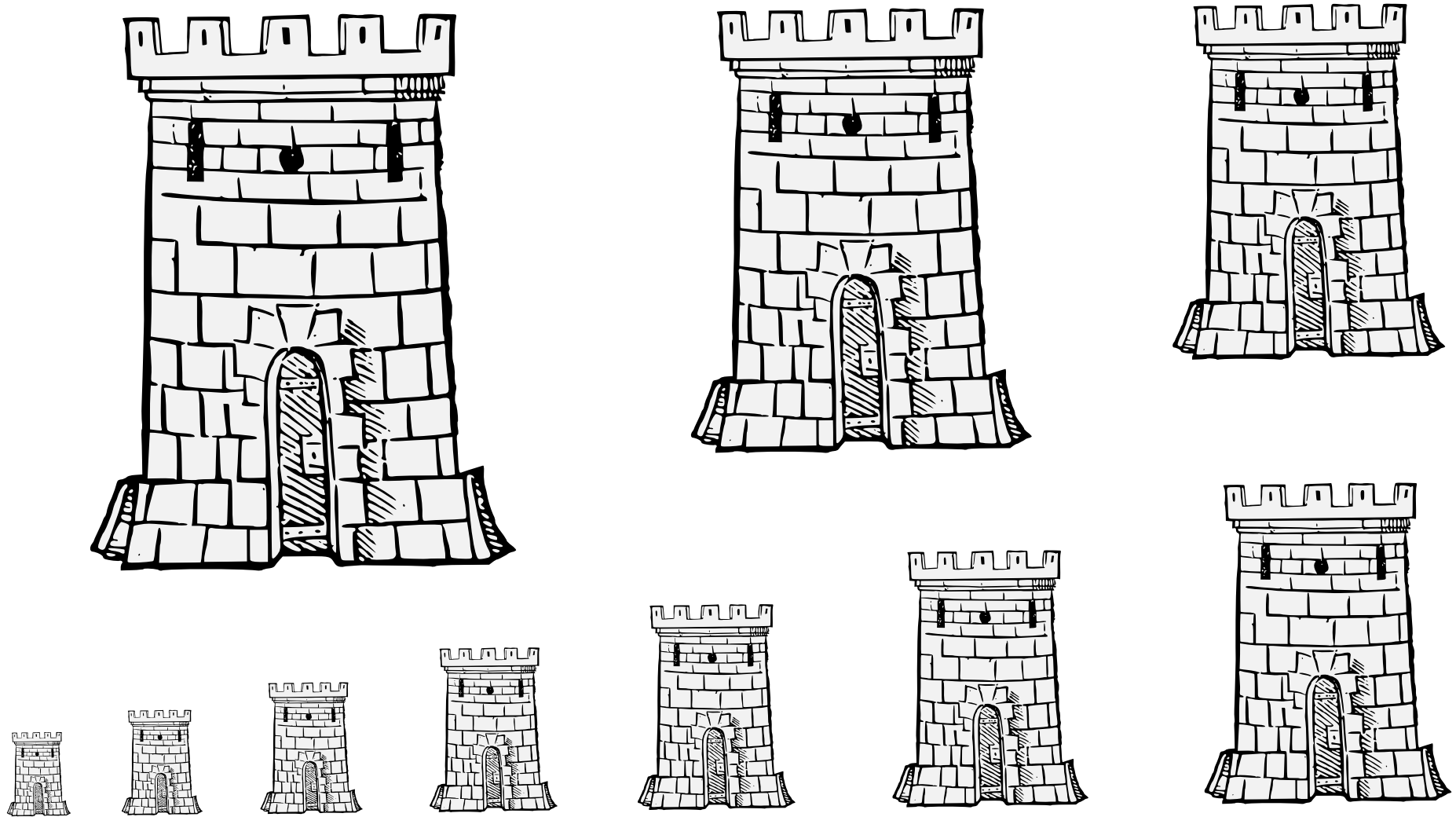

A circular or square stone building as might be found in a castle.

Default orientation: palewise. Proper coloration: argent or gray.

Artist: Iago ab Adam. Adapted from
Catalogue des Noms, Surnoms, Faits et Vies.

Tower (18) 17.199

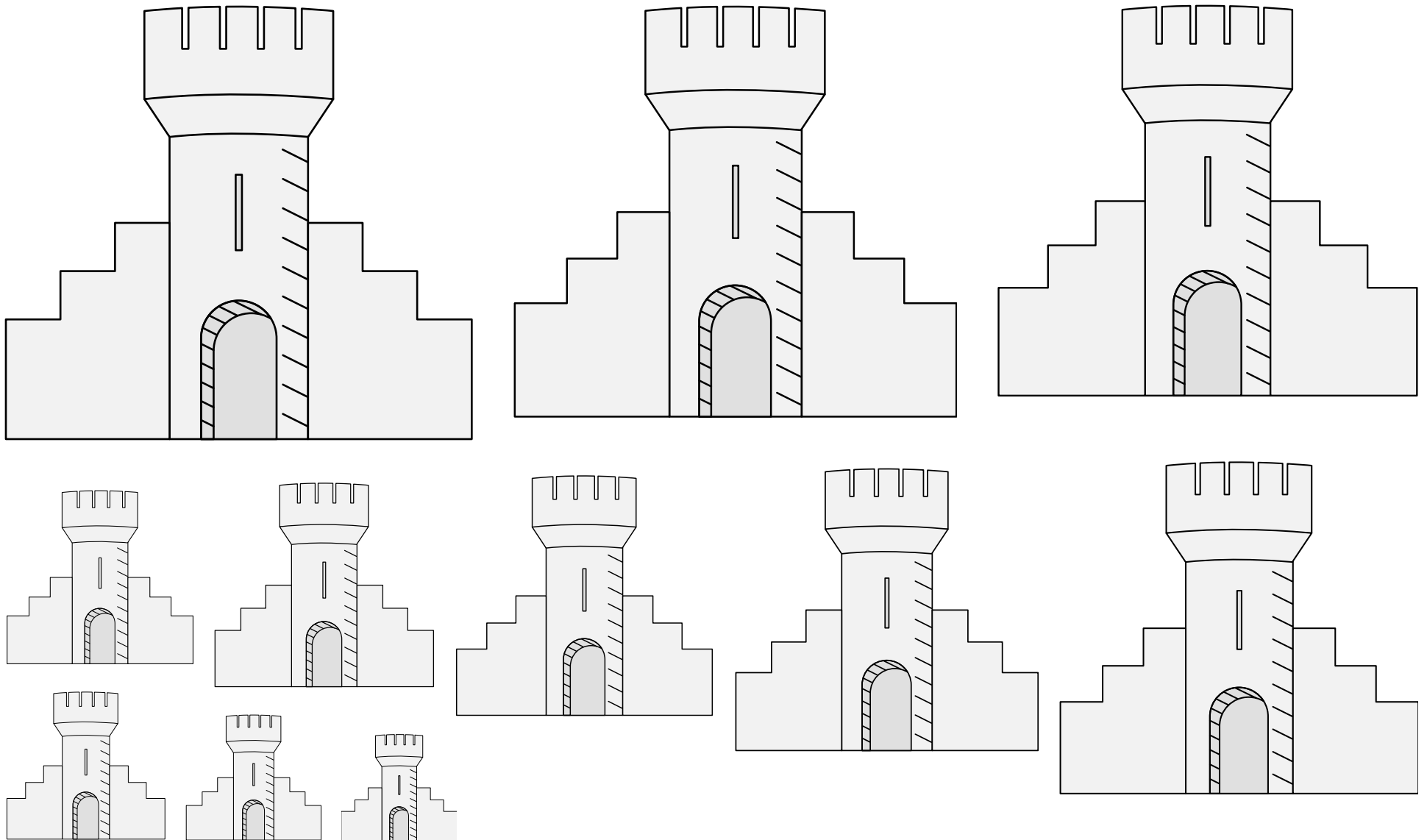

A circular or square stone building as might be found in a castle.

Default orientation: palewise. Proper coloration: argent or gray.

Source: Wappenbuch Conrads von Grüenberg. Artist unknown. (Page 104.)

Tower (19) 17.200

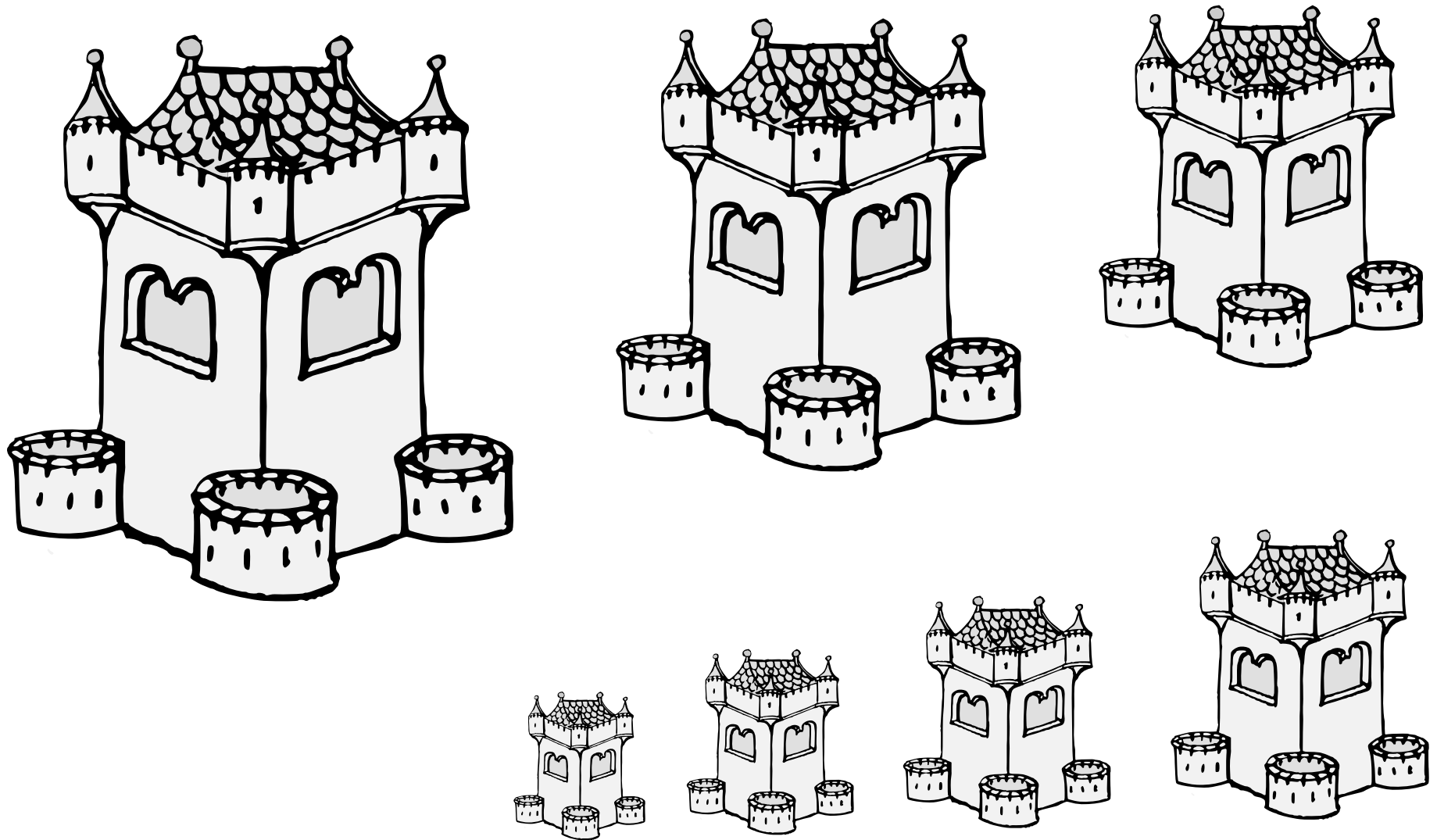

A circular or square stone building as might be found in a castle.

Default orientation: palewise. Proper coloration: argent or gray.

Source: Sammelband Mehrerer Wappenbücher. Artist unknown. (Folio 12r.)

Tower (20) 17.201

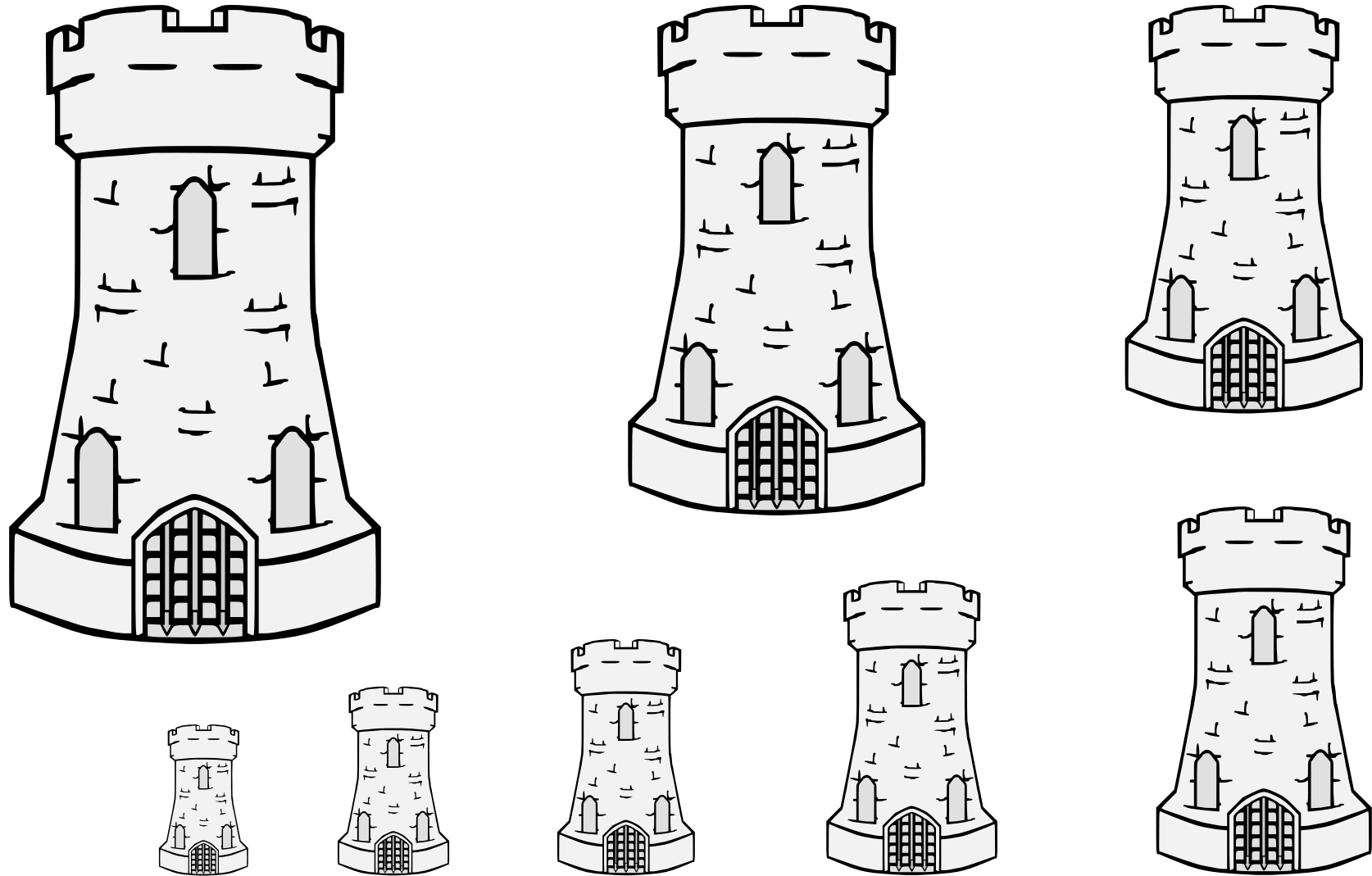

A circular or square stone building as might be found in a castle.

Default orientation: palewise. Proper coloration: argent or gray.

Artist: Jessimond of Emerickeskepe.

Tower (21) 17.202

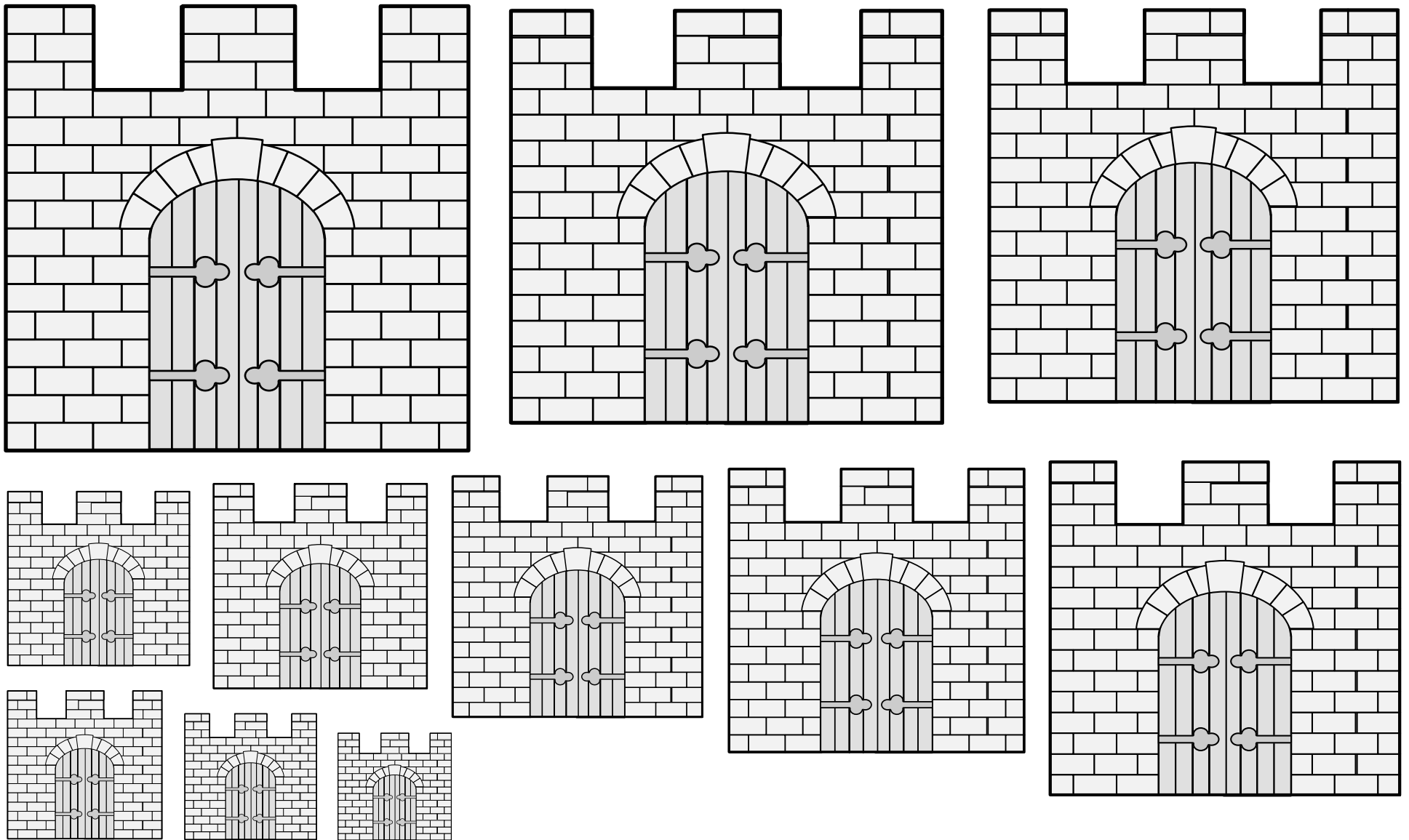

A circular or square stone building as might be found in a castle.

Default orientation: palewise. Proper coloration: argent or gray.

Source: Viking Answer Lady SVG Images For Heraldry.

Artist: Gunnvôr silfrhárr.

Tower (22) 17.203

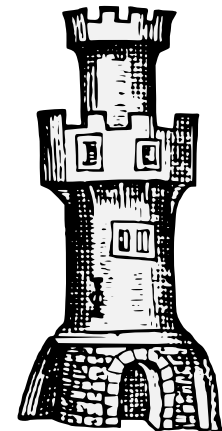
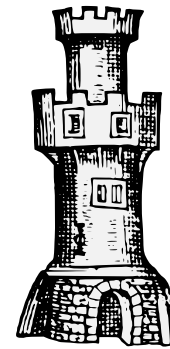
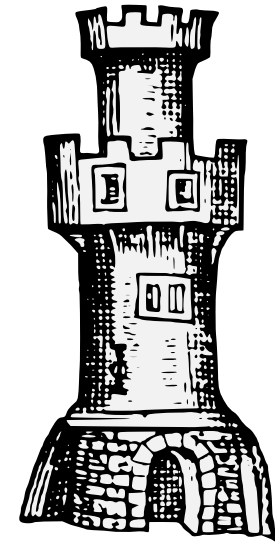
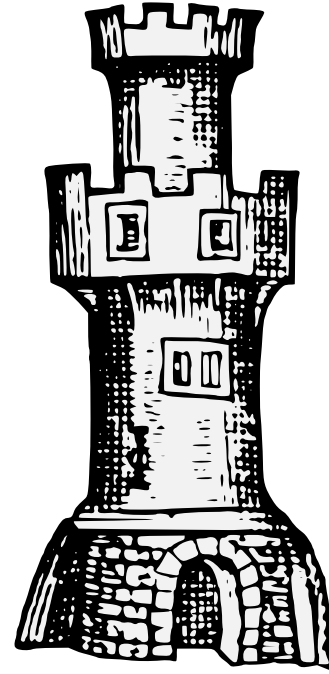
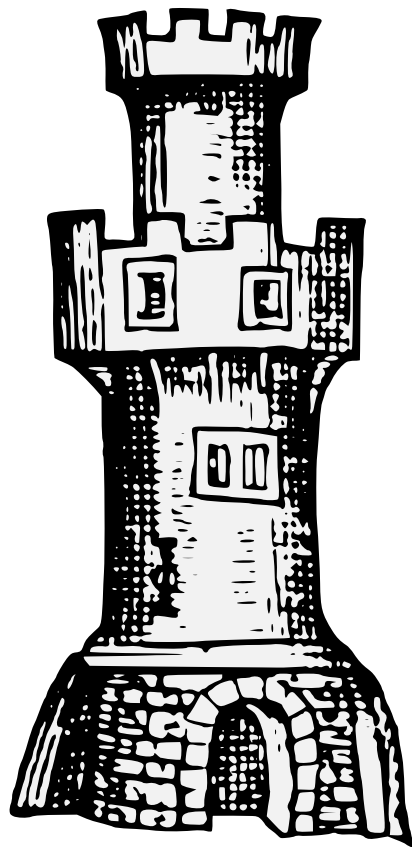

A circular or square stone building as might be found in a castle.
Default orientation: palewise. Proper coloration: argent or gray.
Source: Le Blason Des Armoiries. Artist: Jérôme de Bara. (Page 221.)

Tower (23) 17.204

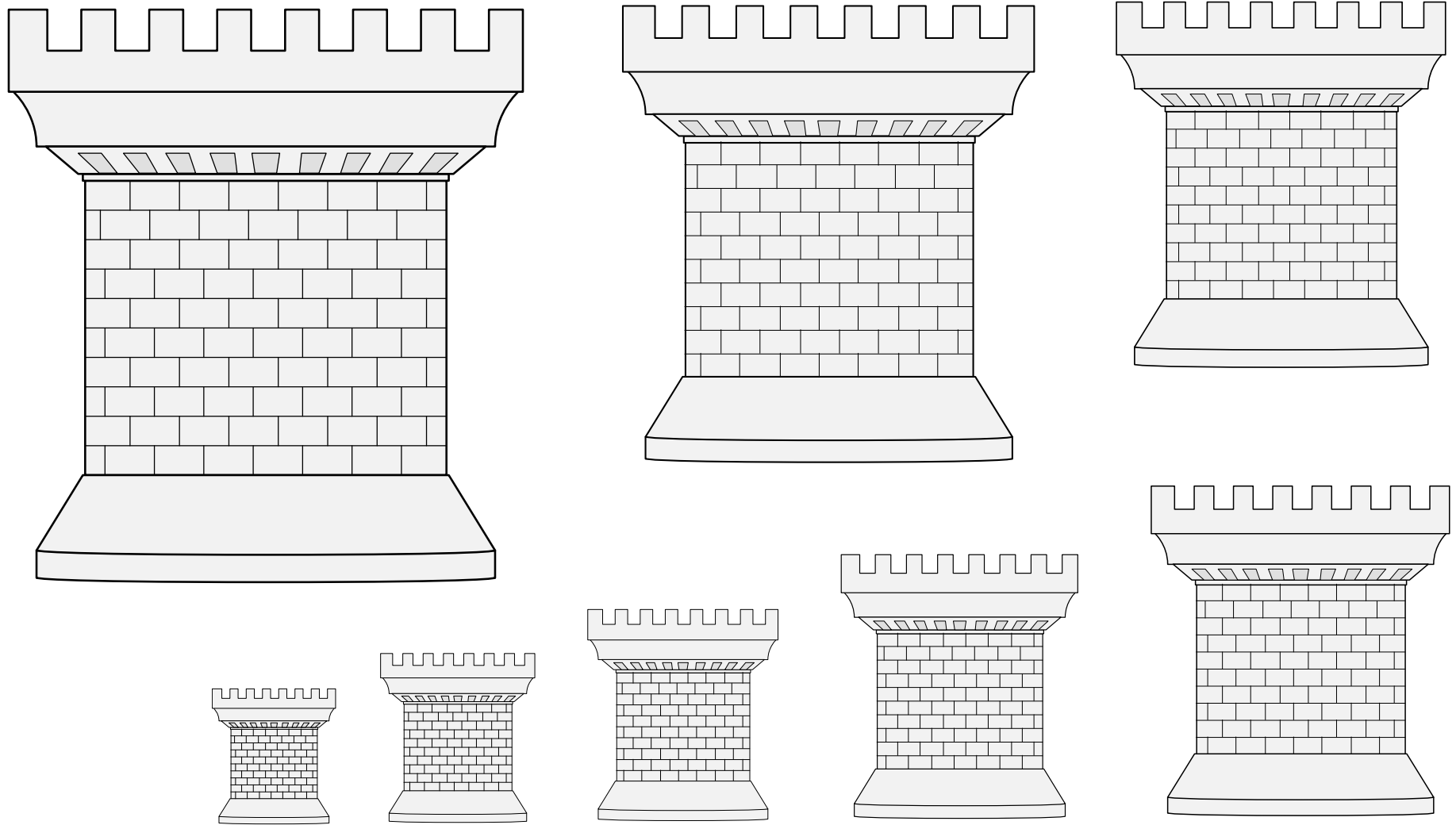

A circular or square stone building as might be found in a castle.

Default orientation: palewise. Proper coloration: argent or gray.

Source: Insignia Nobilium Urbis Romae. Artist unknown.
(Arms of de Friapani, folio 60.) Adapted by Mathghamhain Ua Ruadháin.

Tower (24) 17.205

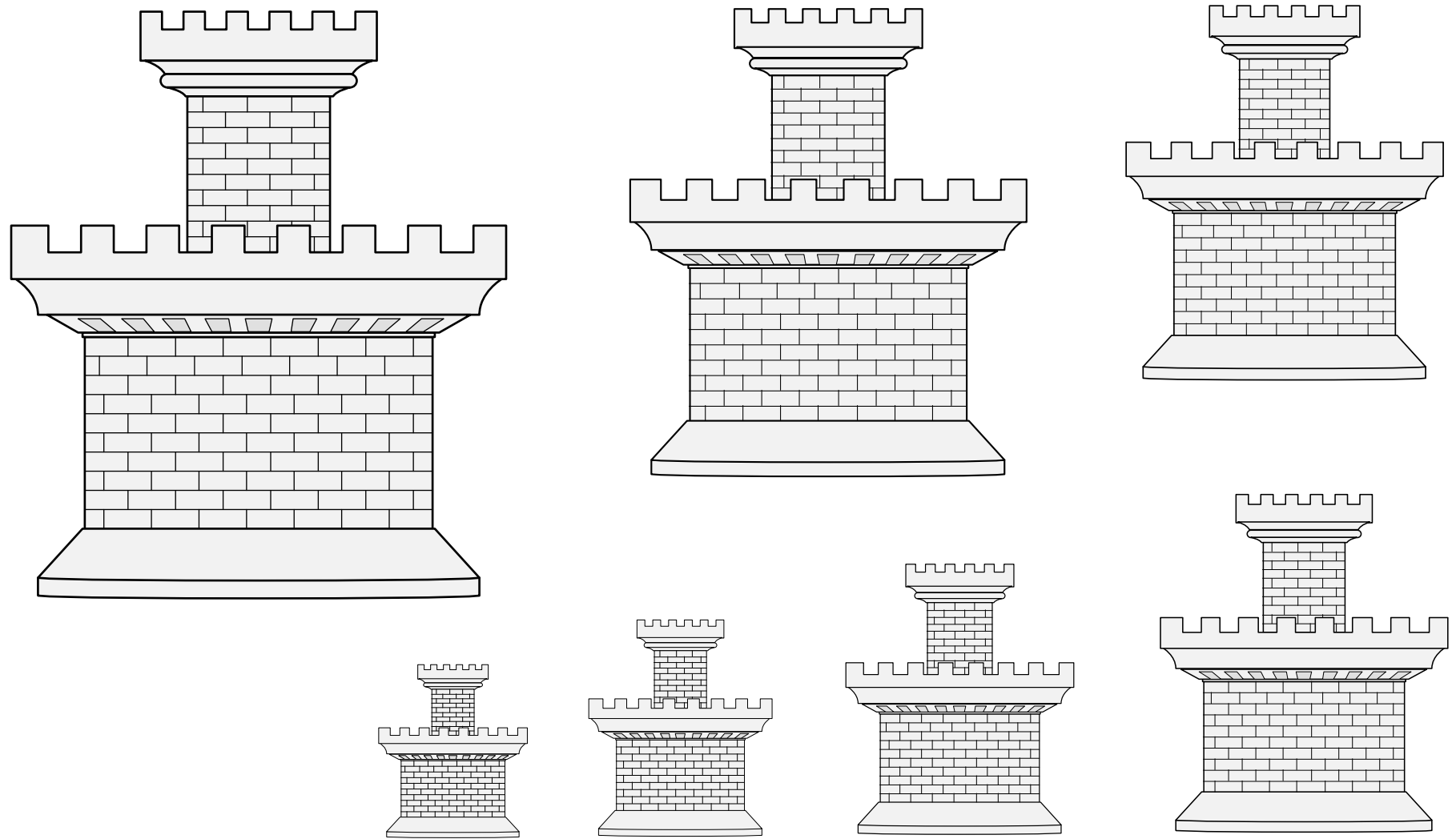

A circular or square stone building as might be found in a castle.

Default orientation: palewise. Proper coloration: argent or gray.

Source: Insignia Nobilium Urbis Romae.

Artist unknown. (Arms of de Friapani, folio 60.)

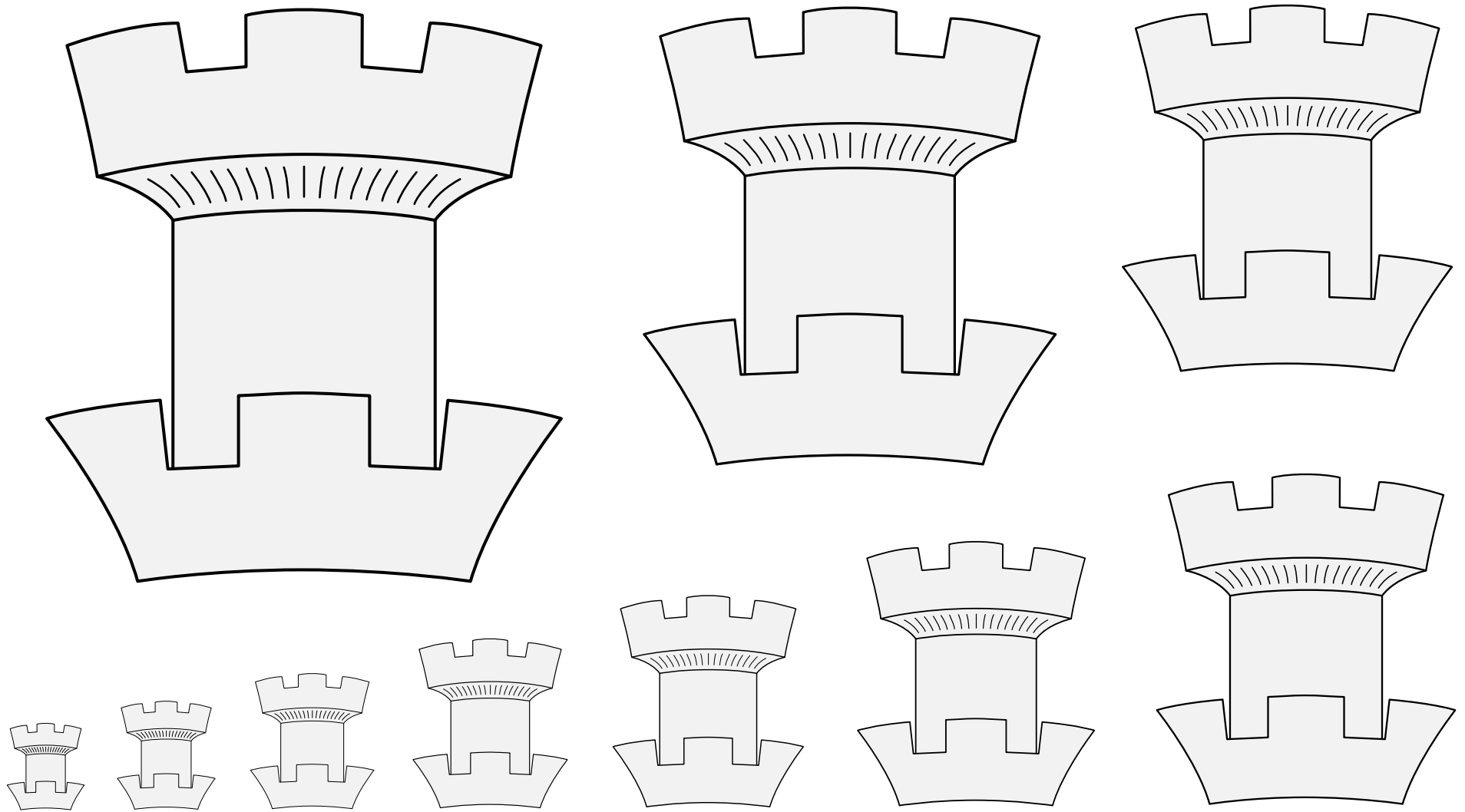

A circular or square stone building as might be found in a castle.
Default orientation: palewise. Proper coloration: argent or gray.
Source: Donaueschinger Wappenbuch. Artist unknown. (Folio 13r.)

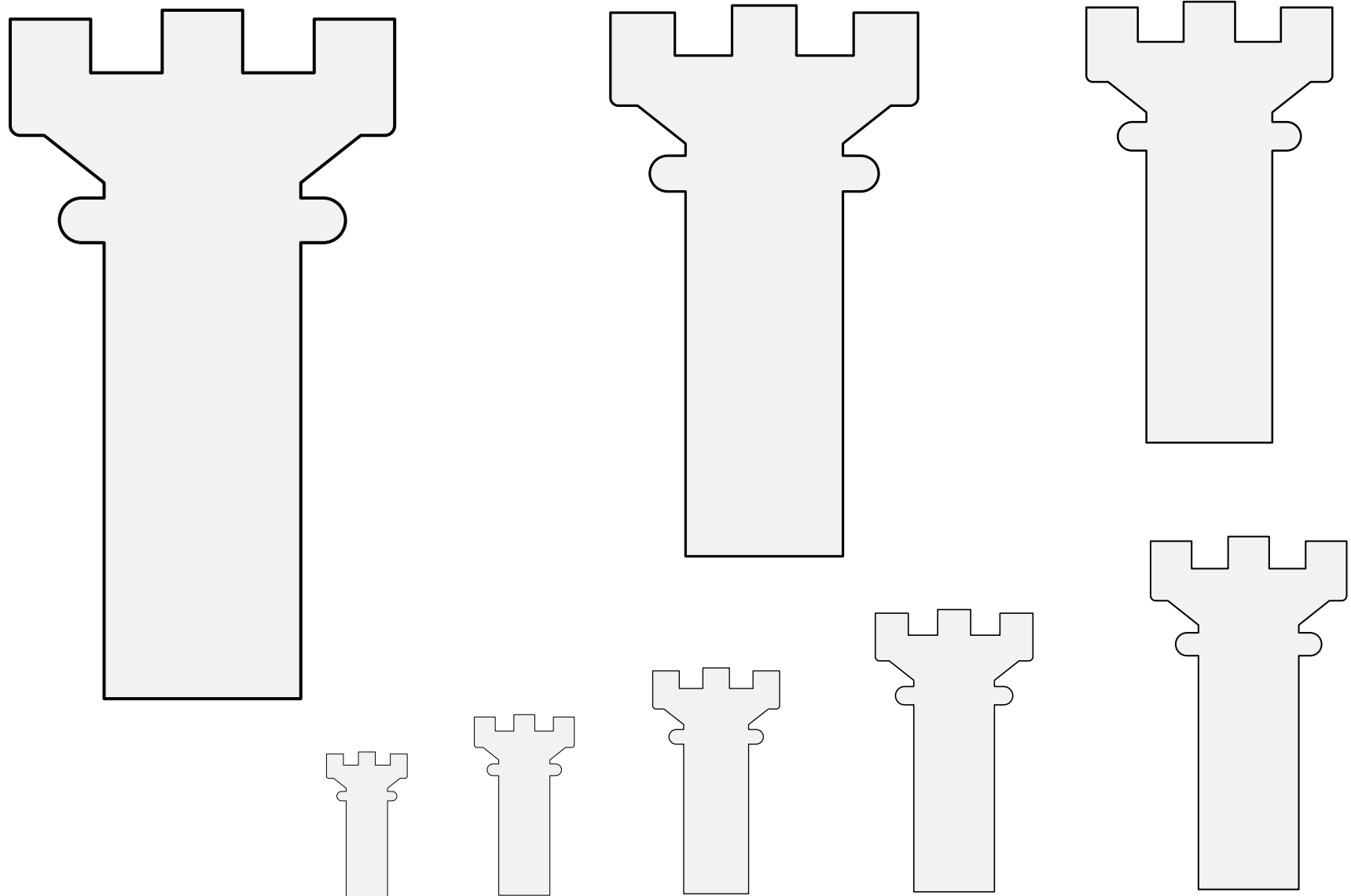

A circular or square stone building as might be found in a castle.
Default orientation: palewise. Proper coloration: argent or gray.
Source: BnF MS Allemand 304. Artist unknown. (Page 577.)

Tower (27) 17.208

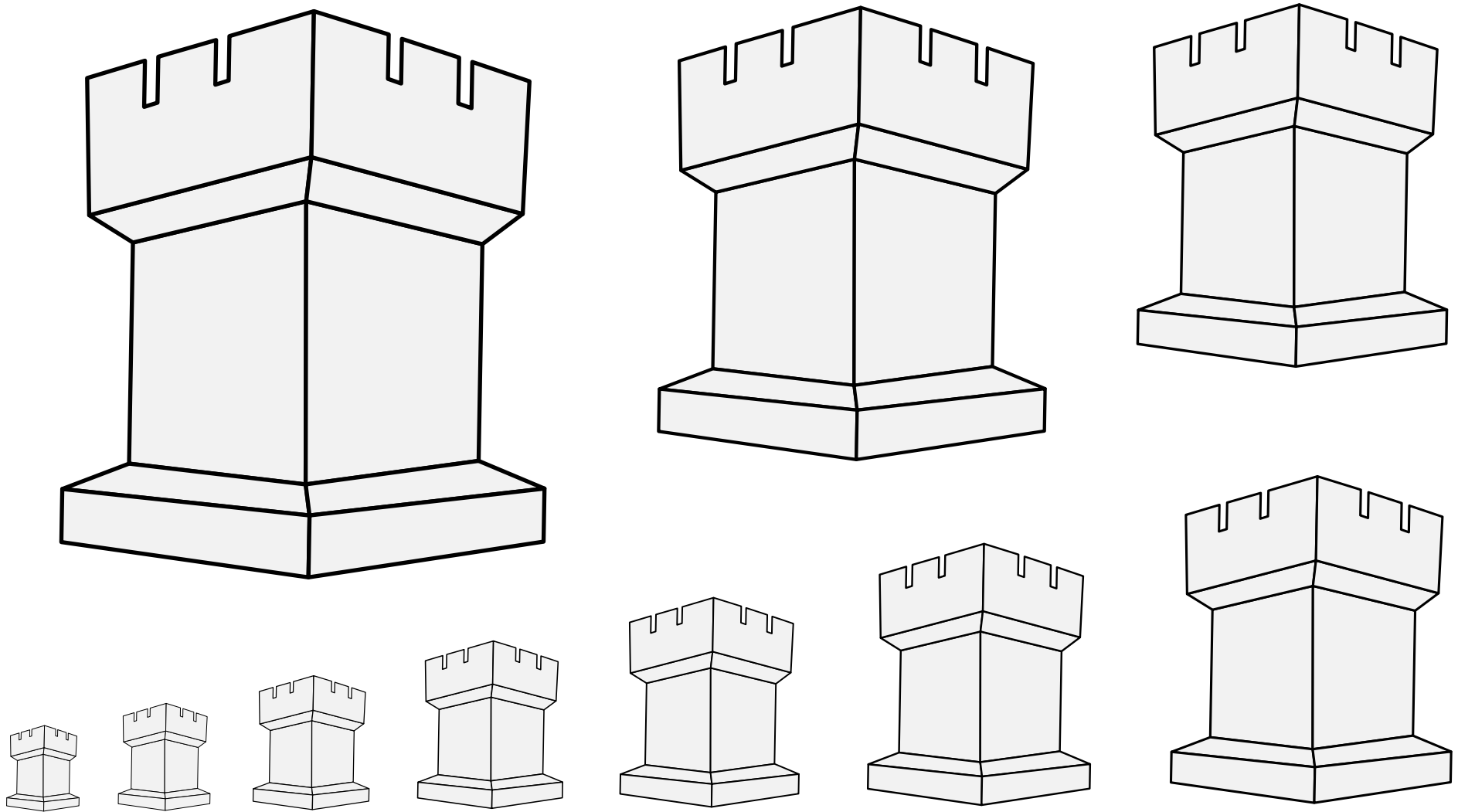

A circular or square stone building as might be found in a castle.

Default orientation: palewise. Proper coloration: argent or gray.

Source: Sammelband Mehrerer Wappenbücher. Artist unknown. (Folio 152v.)

Tower (28) 17.209

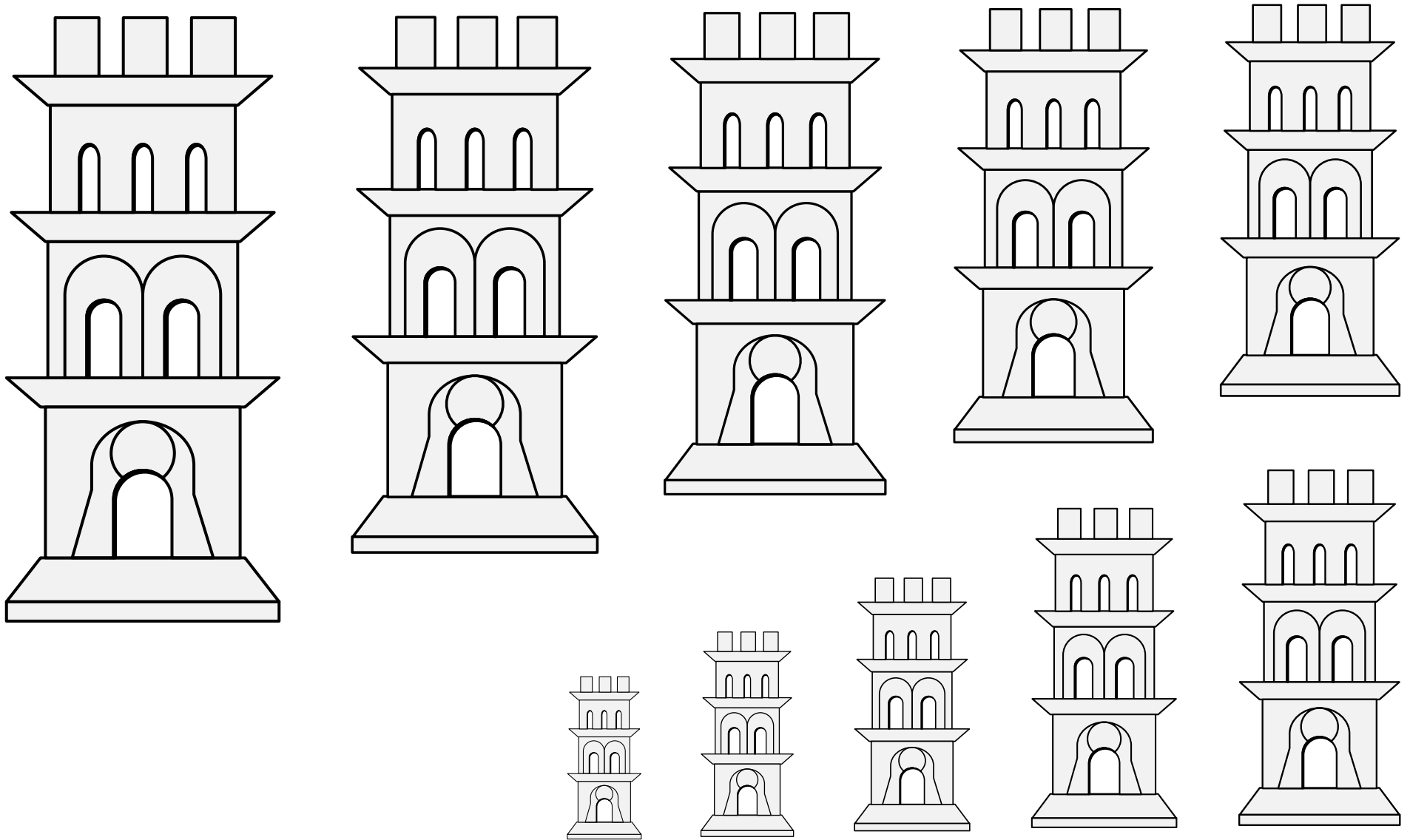

A circular or square stone building as might be found in a castle.

Default orientation: palewise. Proper coloration: argent or gray.

Source: Stemmario Trivulziano. Artist: Gian Antonio da Tradate.
(Page 163, arms of de Gorgonzolla.)

Tower (29) 17.210

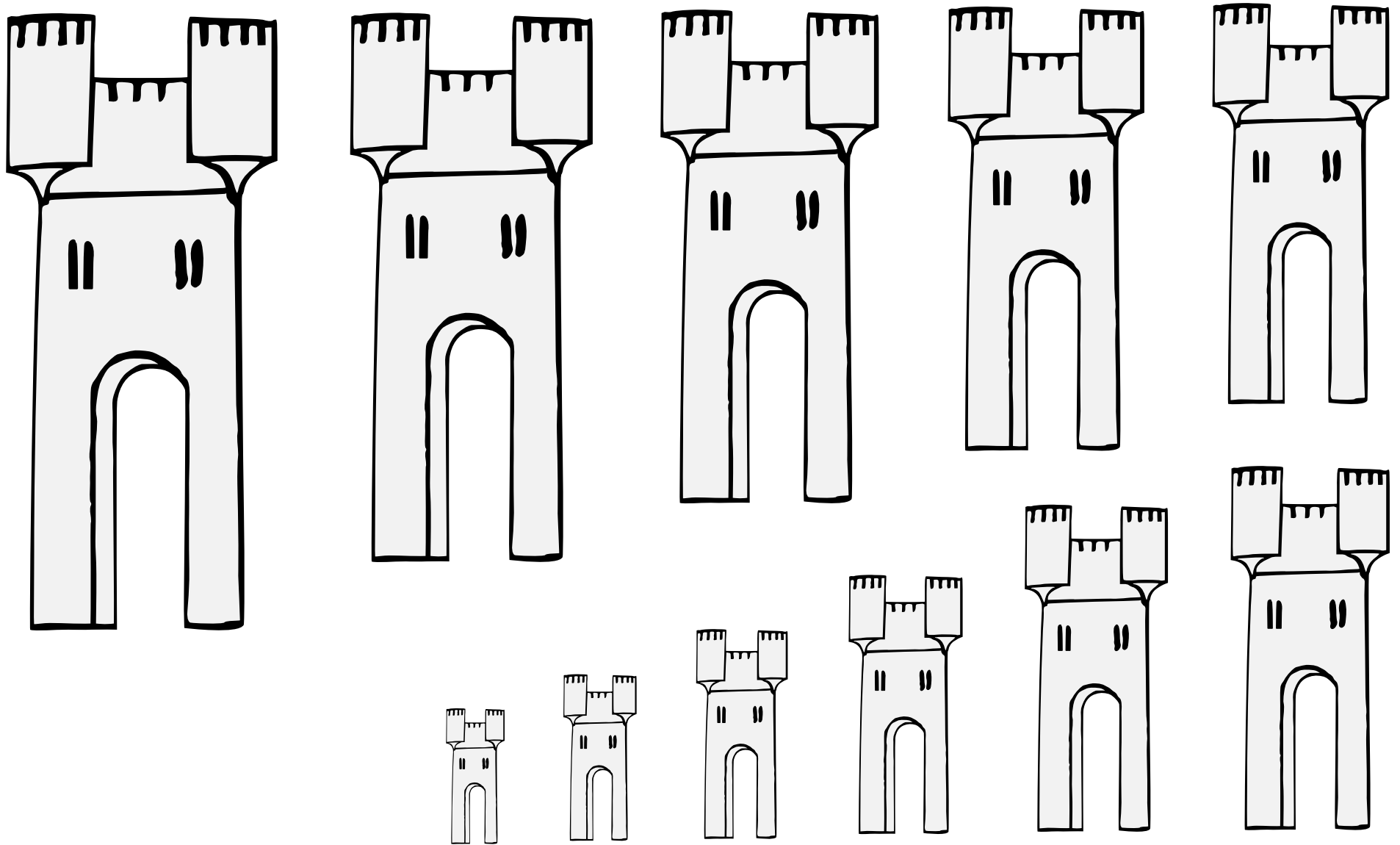

A circular or square stone building as might be found in a castle.

Default orientation: palewise. Proper coloration: argent or gray.

Source: Sammelband Mehrerer Wappenbücher. Artist unknown. (Folio 155r.)

Tower (30) 17.211

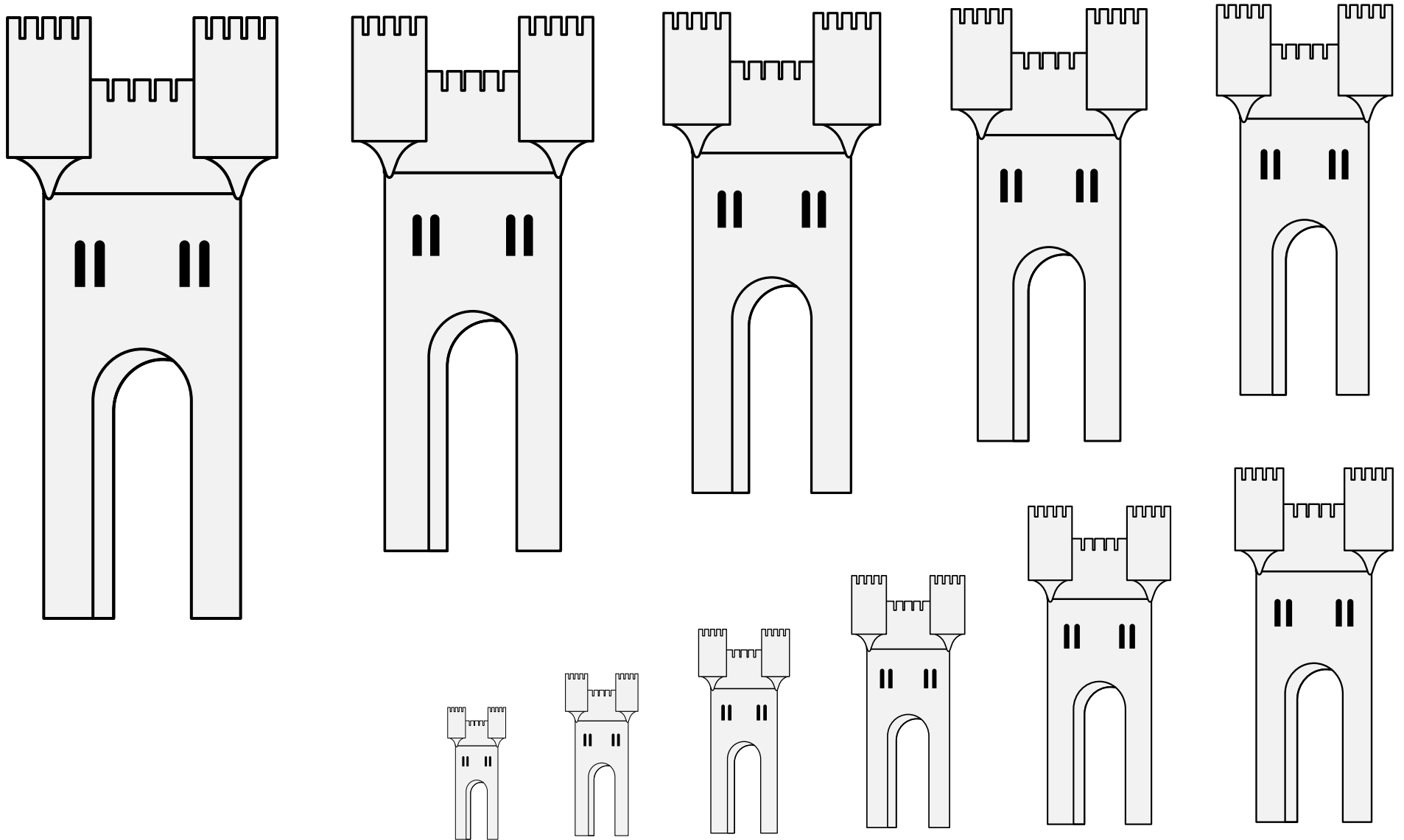

A circular or square stone building as might be found in a castle.

Default orientation: palewise. Proper coloration: argent or gray.

Source: Sammelband Mehrerer Wappenbücher. Artist unknown. (Folio 155r.)

Adapted by Mathghamhain Ua Ruadháin.

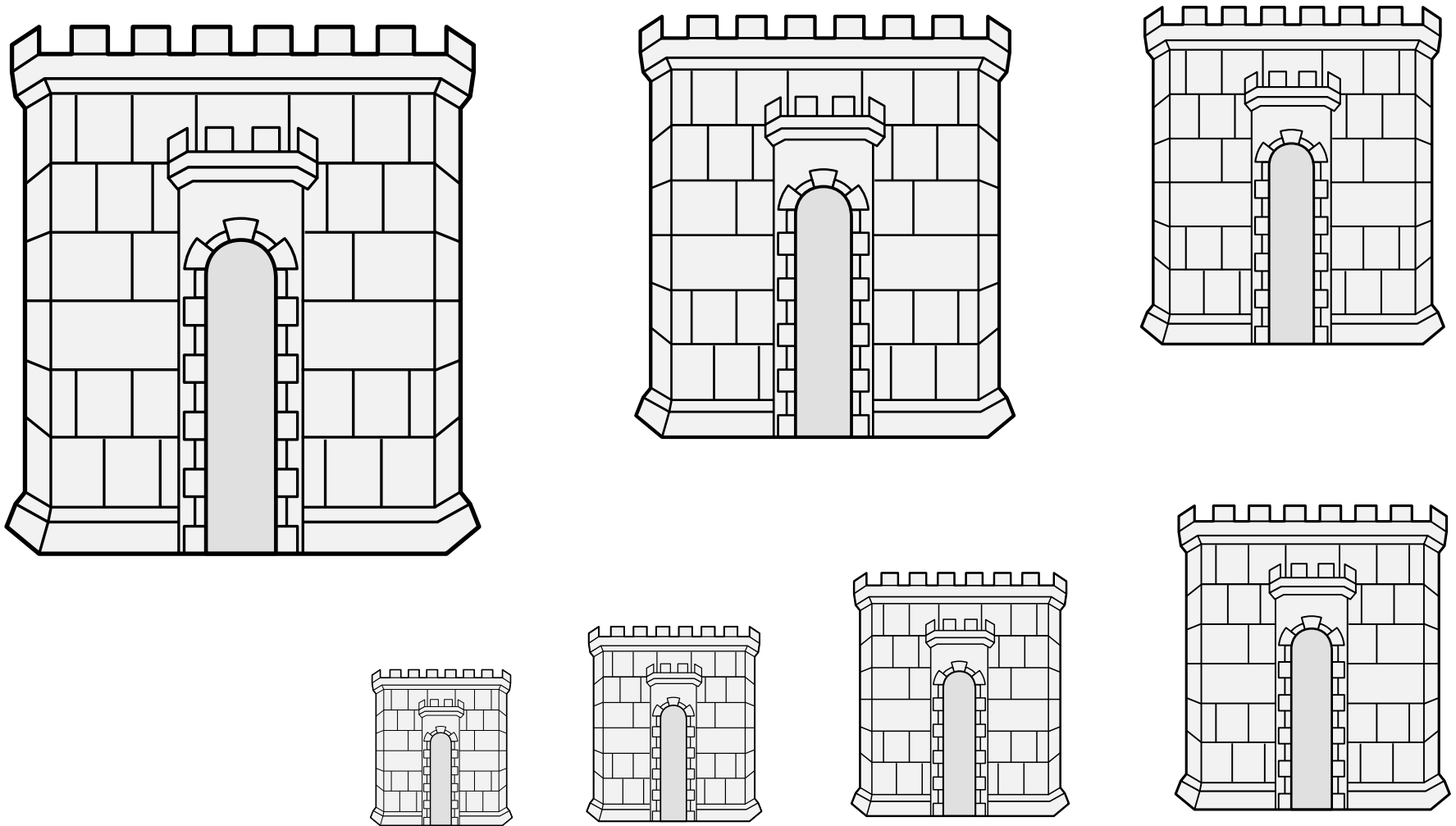

A circular or square stone building as might be found in a castle.

Default orientation: palewise. Proper coloration: argent or gray.

Source: WappenWiki. Artist: Joakim Spuller.

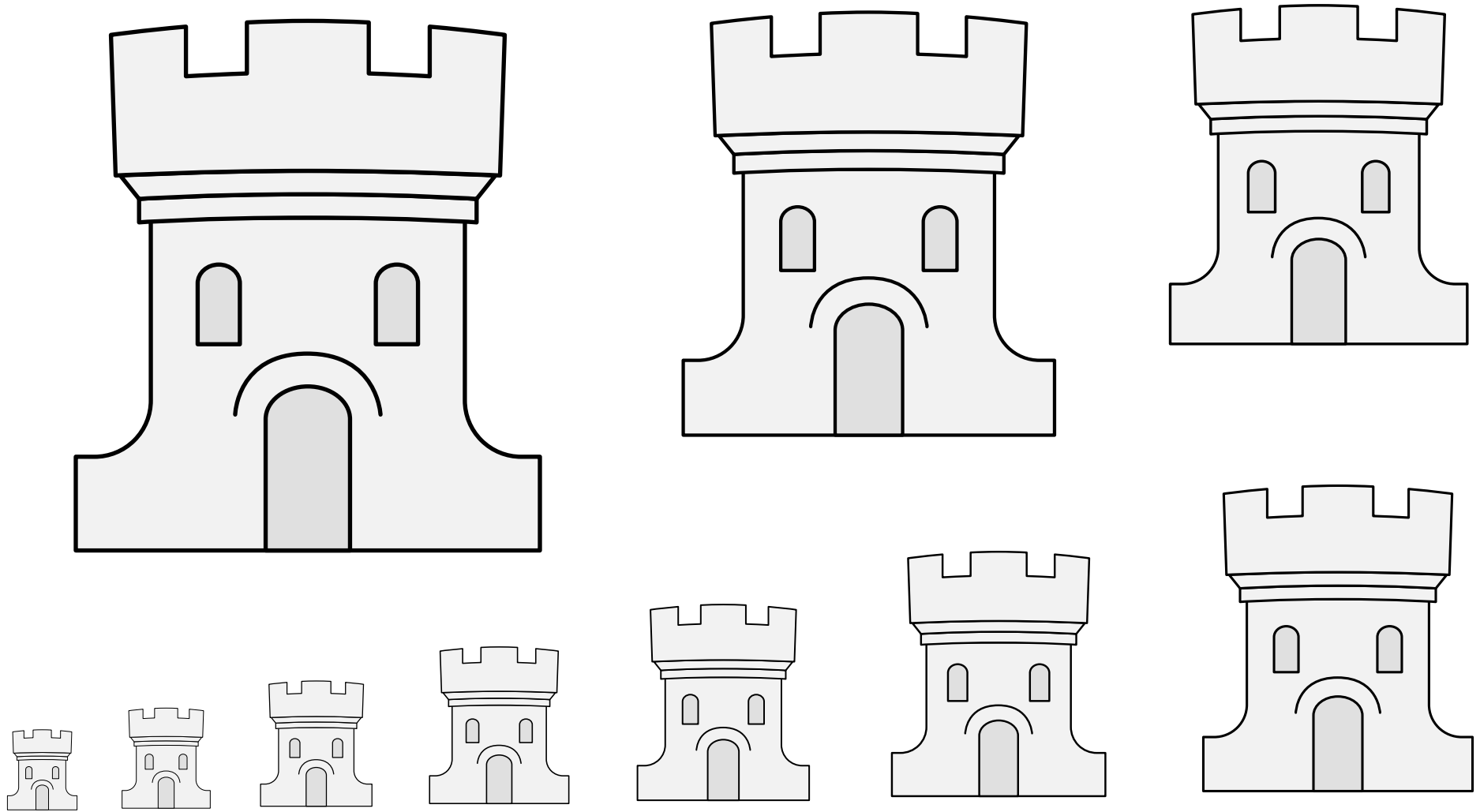

A circular or square stone building as might be found in a castle.

Default orientation: palewise. Proper coloration: argent or gray.

Source: Wapenboek van Gent. Artist: Vander Schelden. (Volume 1, page 99.)

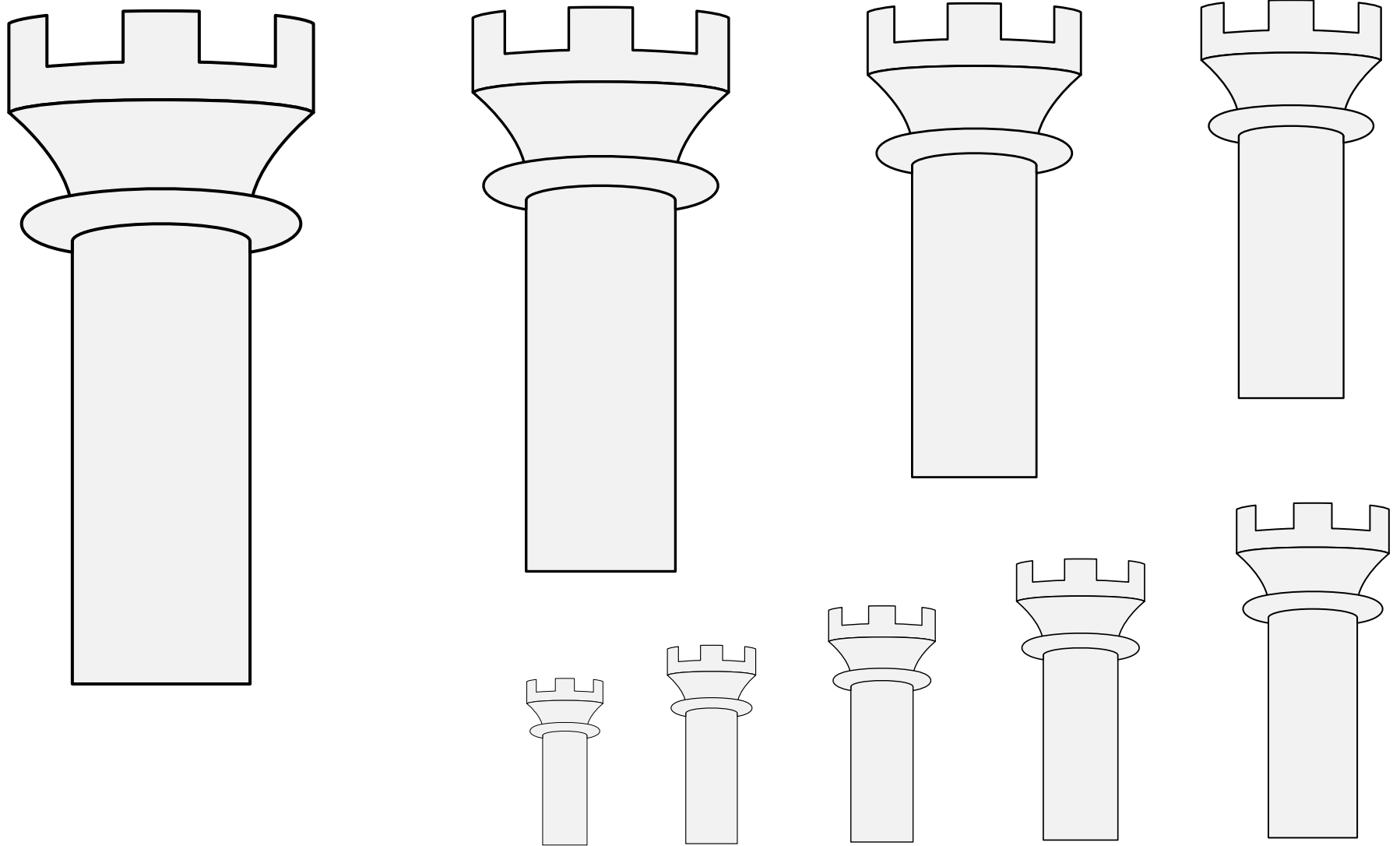

A circular or square stone building as might be found in a castle.
Default orientation: palewise. Proper coloration: argent or gray.
Source: Wernigerode Armorial. Artist unknown. (Page 511.)

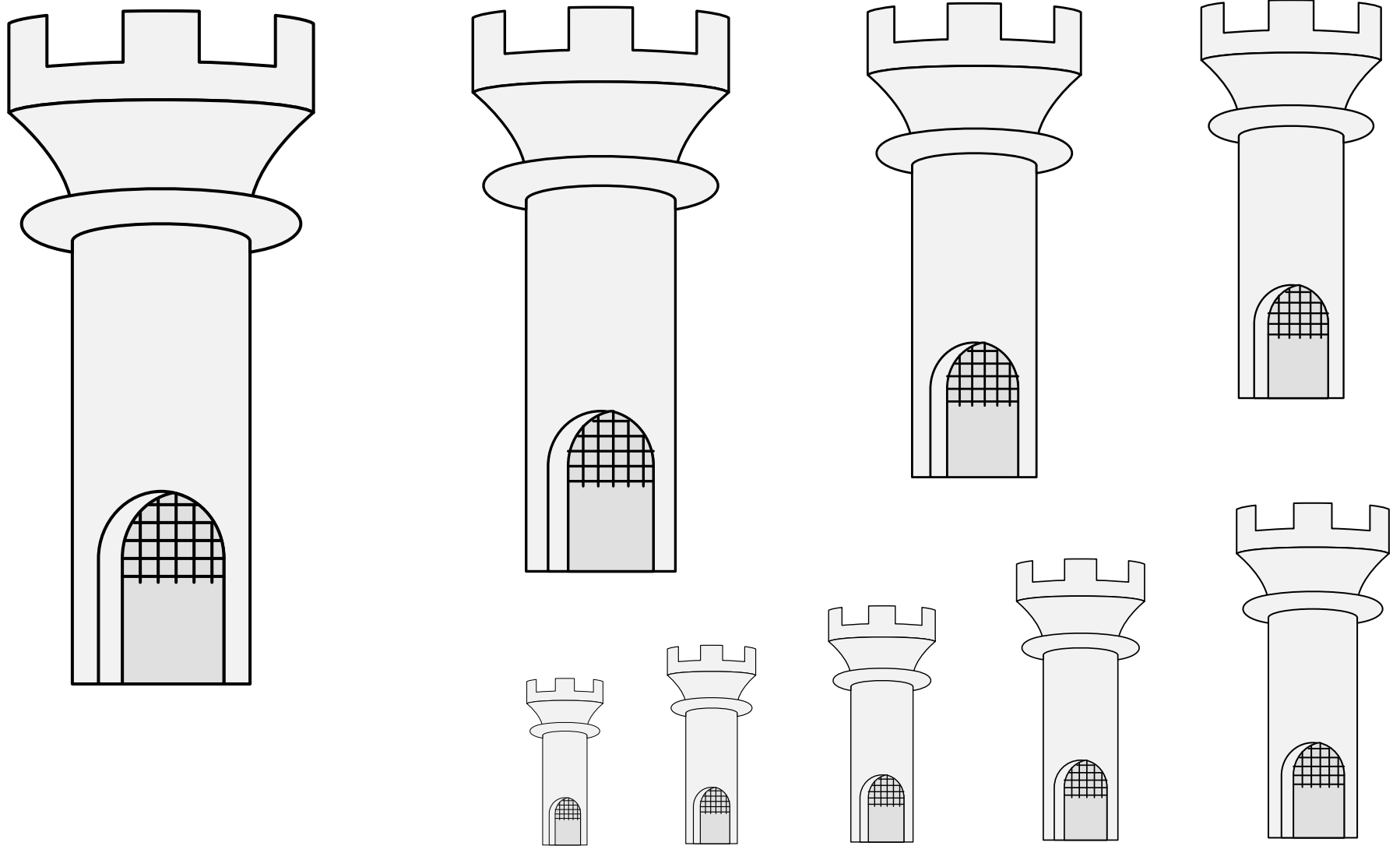

A circular or square stone building as might be found in a castle.

Default orientation: palewise. Proper coloration: argent or gray.

Source: Wernigerode Armorial. Artist unknown. (Page 511.)

Tower (35) 17.216

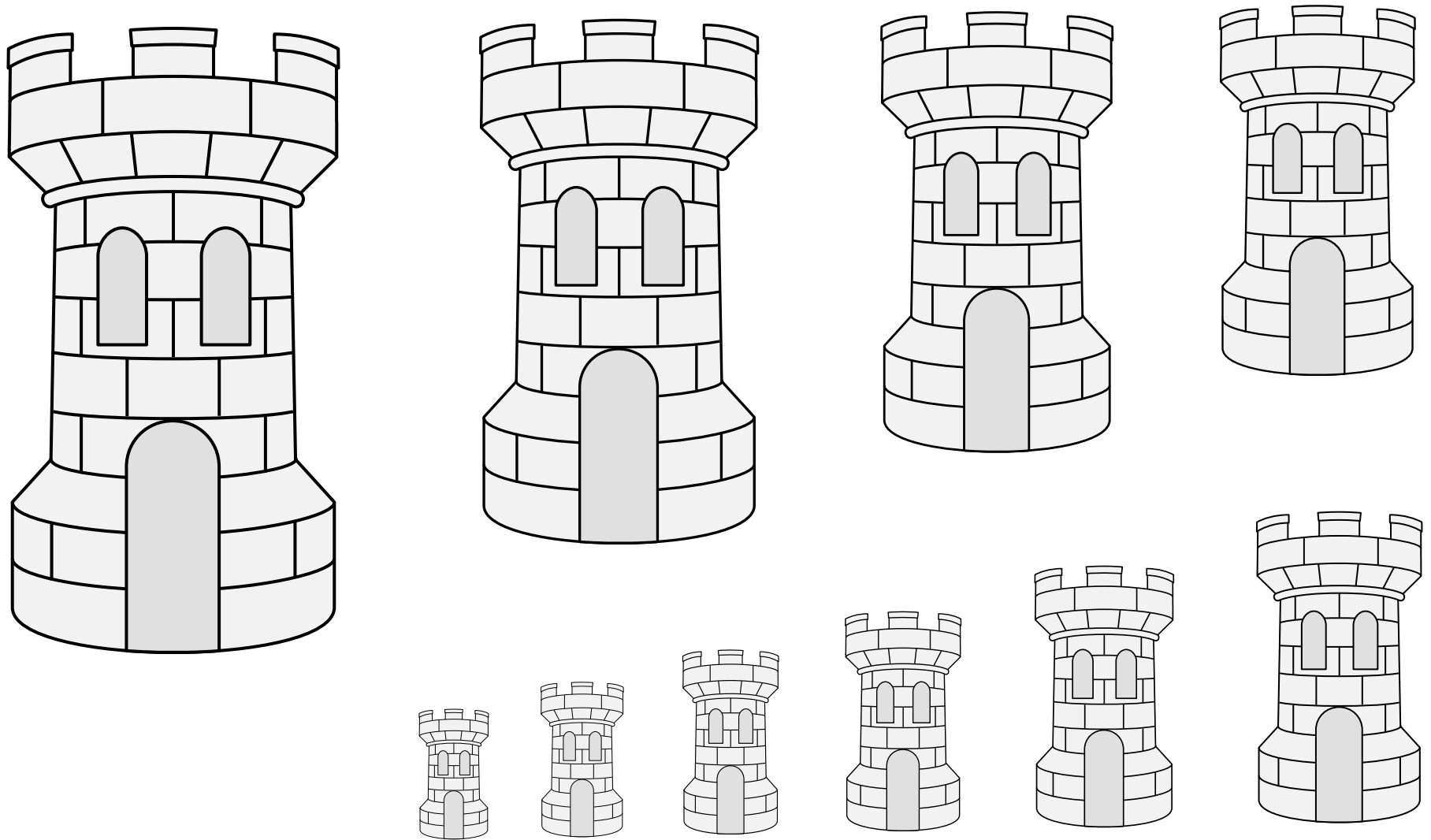

A circular or square stone building as might be found in a castle.

Default orientation: palewise. Proper coloration: argent or gray.

Source: WappenWiki. Artist: Joakim Spuller.

Tower (36) 17.217

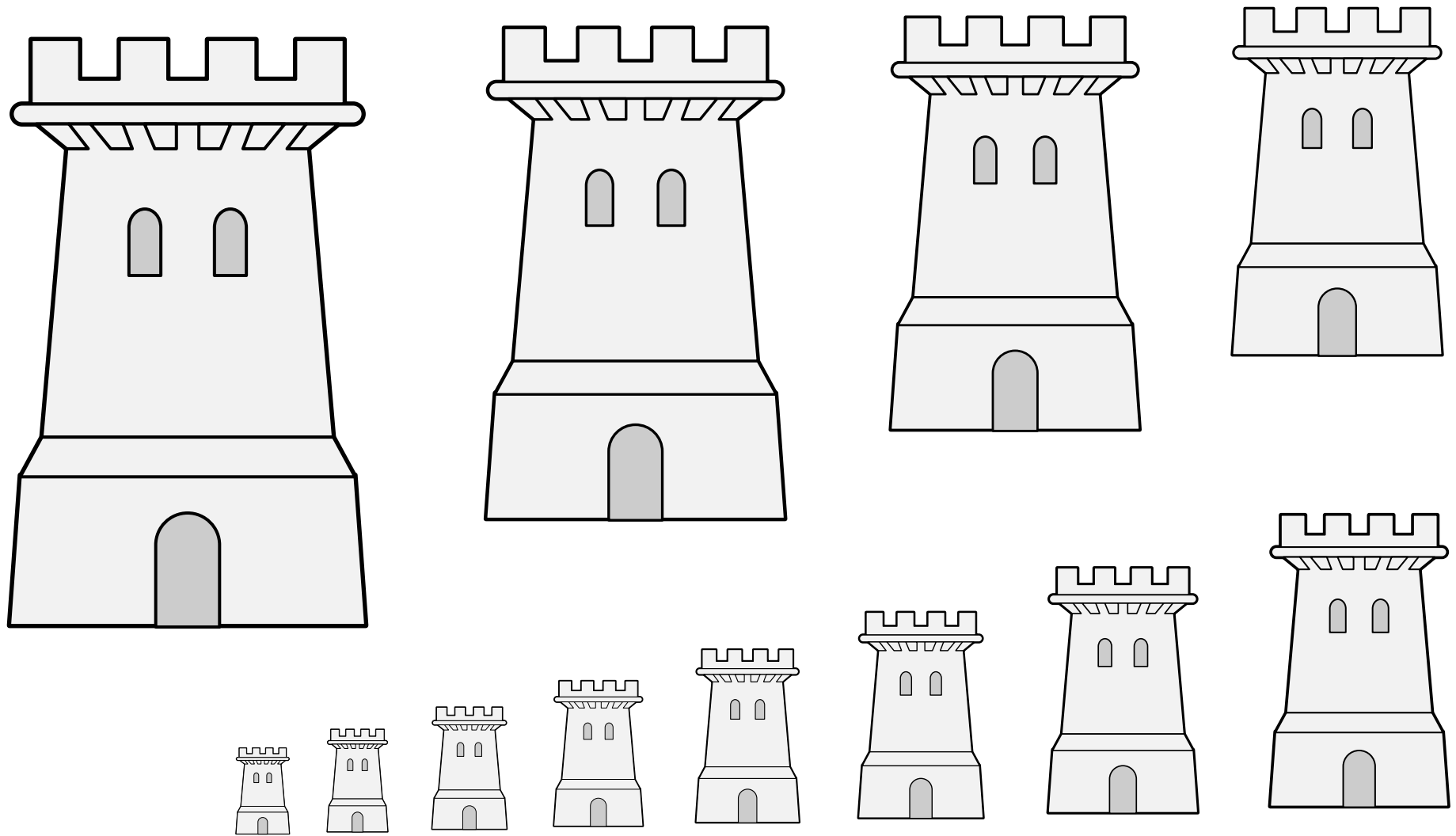

A circular or square stone building as might be found in a castle.

Default orientation: palewise. Proper coloration: argent or gray.

Source: Viking Answer Lady SVG Images For Heraldists. Artist: Gunnvör silfrahárr.
Adapted by Mathghamhain Ua Ruadháin.

Tower (37) 17.218

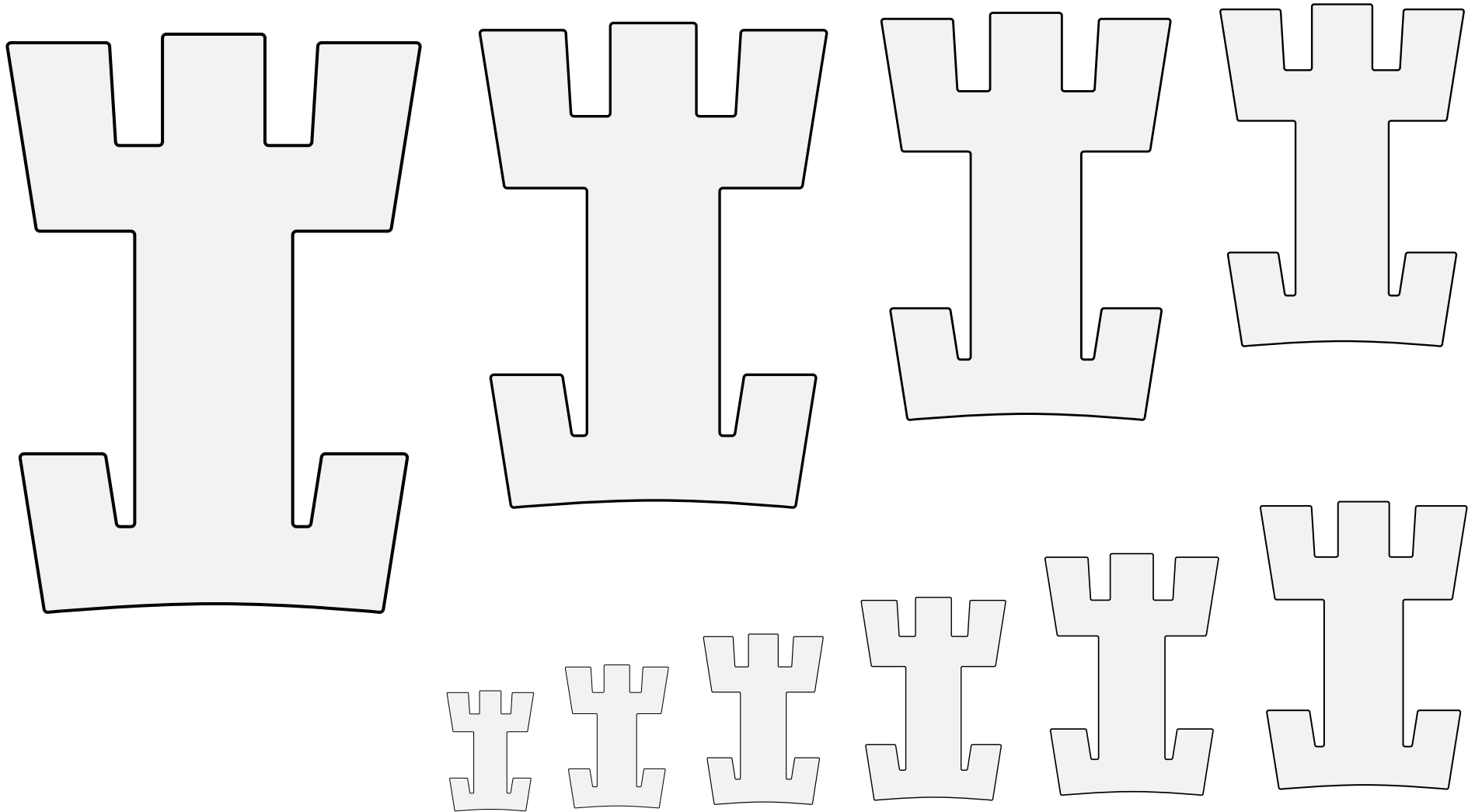

A circular or square stone building as might be found in a castle.

Default orientation: palewise. Proper coloration: argent or gray.

Source: Zurich Roll. Artist unknown. (Folio 4r.)

Tower (38) 17.219

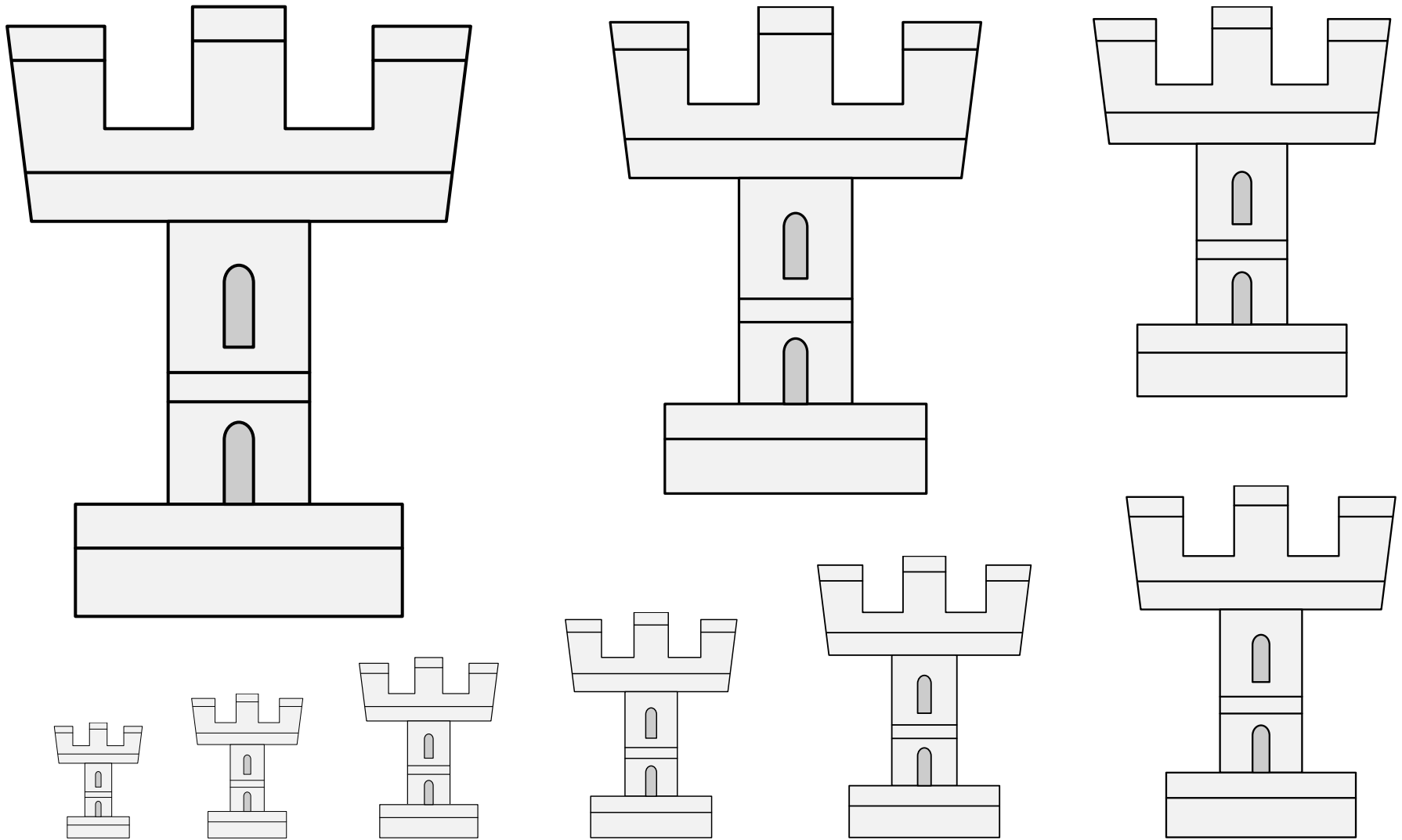

A circular or square stone building as might be found in a castle.

Default orientation: palewise. Proper coloration: argent or gray.

Source: Zurich Roll. Artist unknown. (Folio 4r.)

Tower (39) 17.220

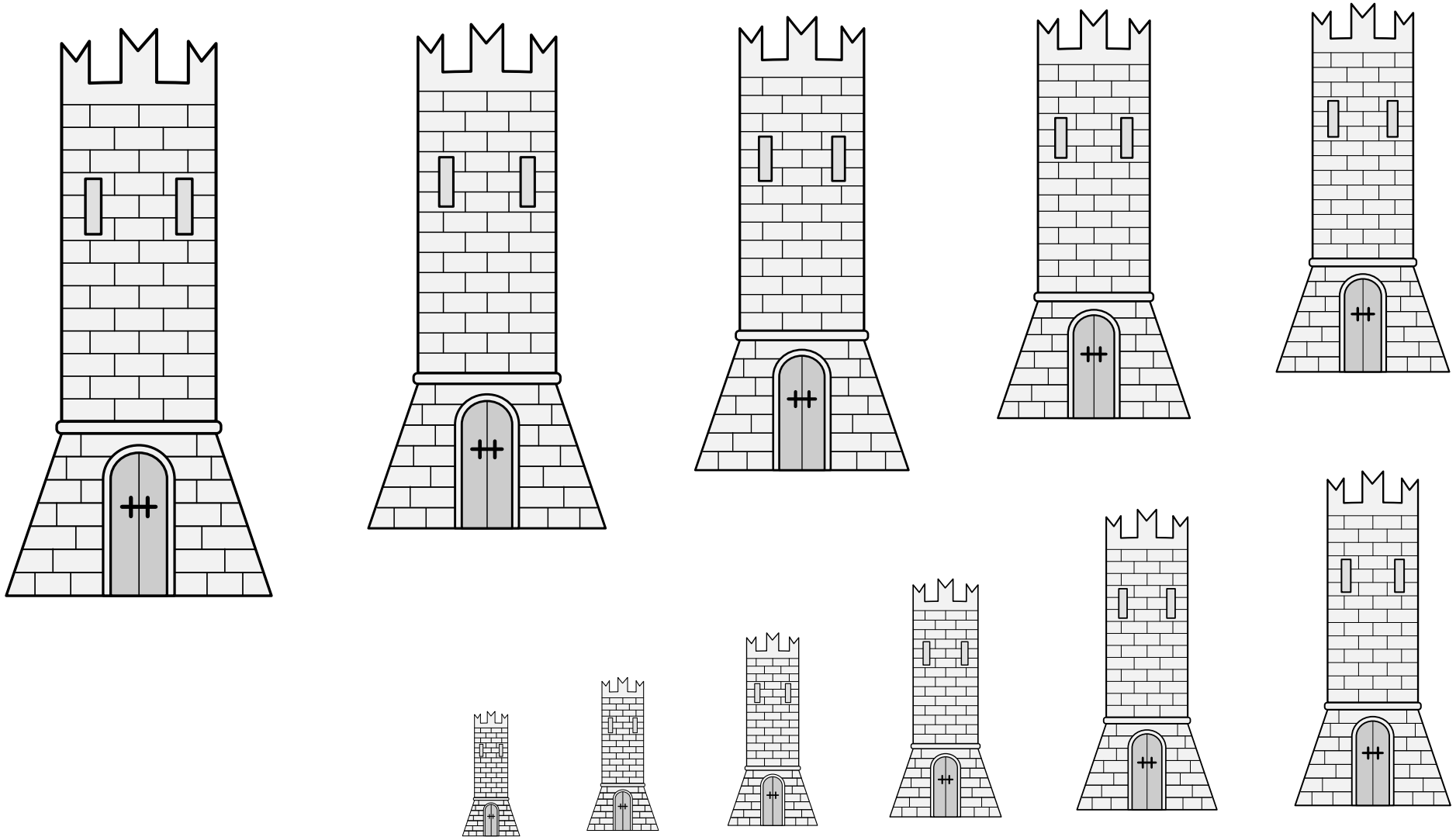

A circular or square stone building as might be found in a castle.

Default orientation: palewise. Proper coloration: argent or gray.

Source: Insegne di Vari Principi et Case Illustri d'Italia.

Artist: Giacomo Fontana. (Arms of Seraglii.)

Tower (40) 17.221

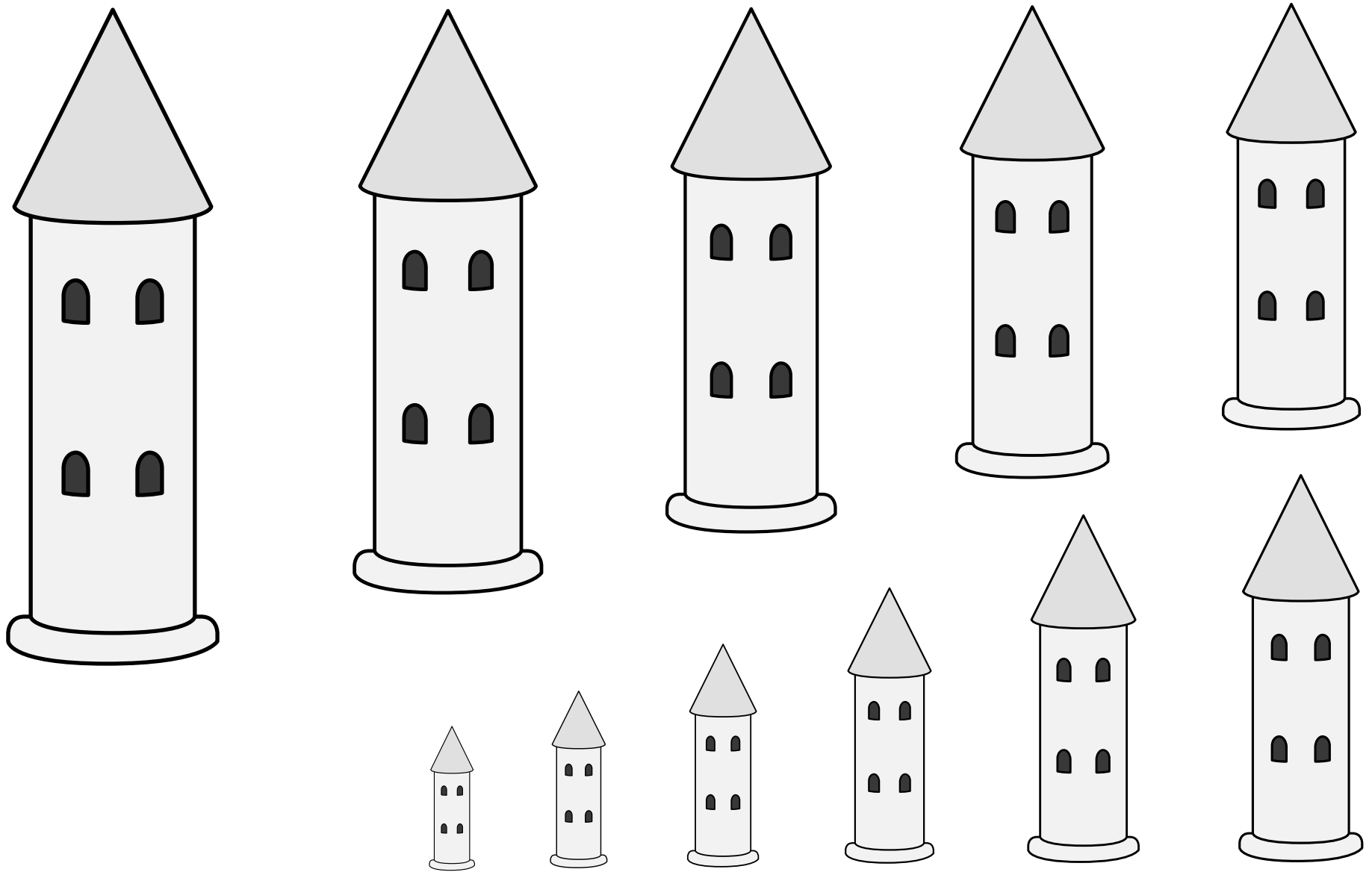

A circular or square stone building as might be found in a castle.
Default orientation: palewise. Proper coloration: argent or gray.

Tower (41) 17.222

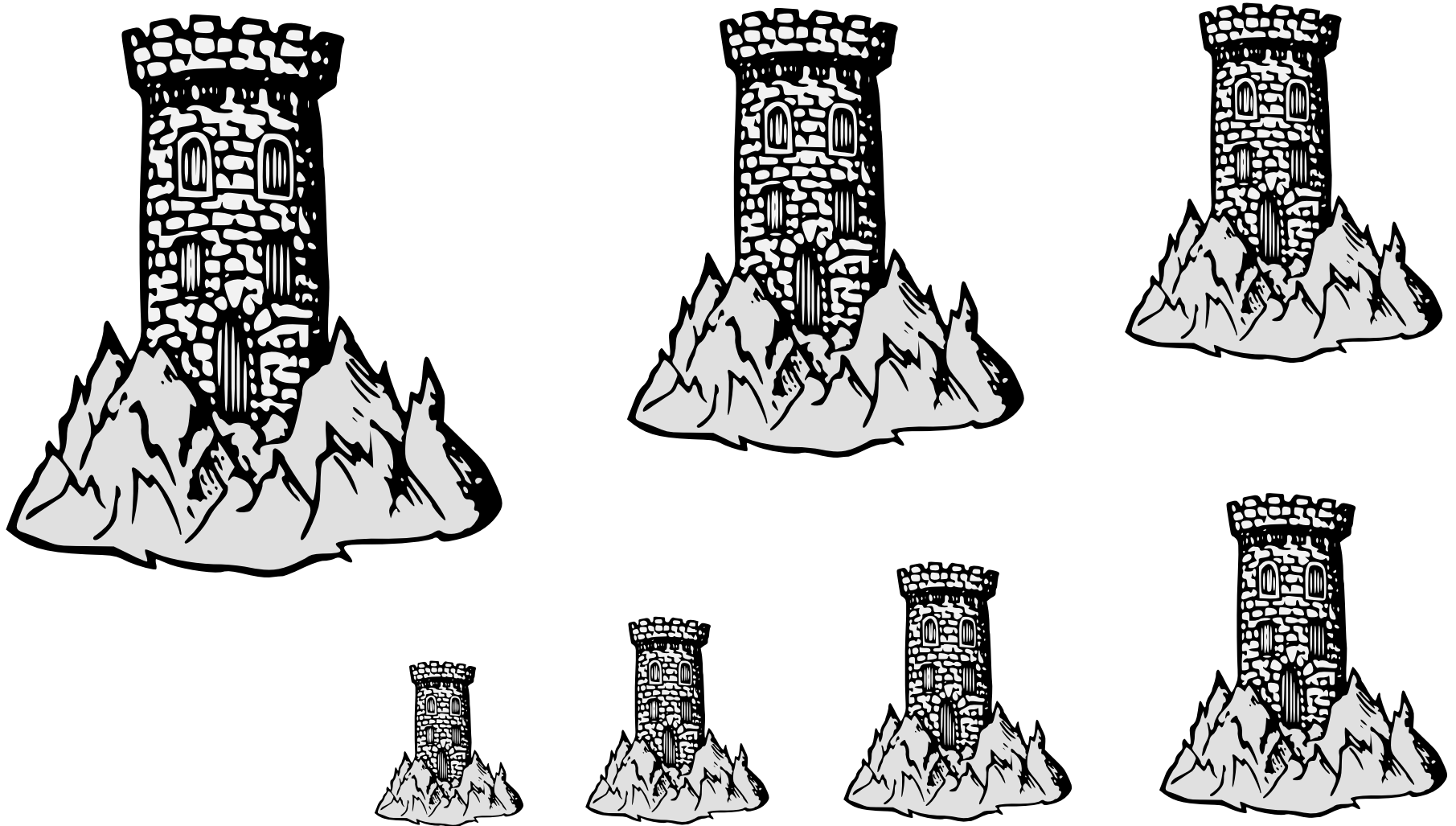

A circular or square stone building as might be found in a castle.

Default orientation: palewise. Proper coloration: argent or gray.

Source: Catalogue des Noms, Surnoms, Faits et Vies.

Artist unknown. (Folio 21r.)

Tower Issuant from a Rock 17.223

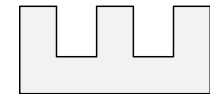
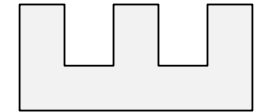
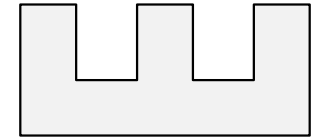
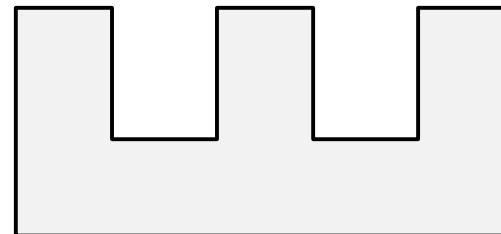
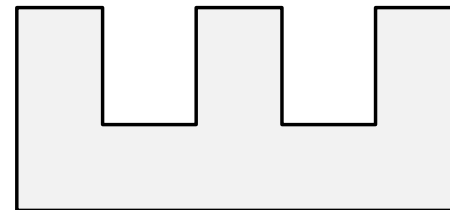
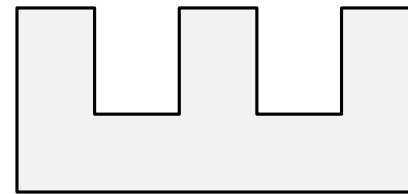
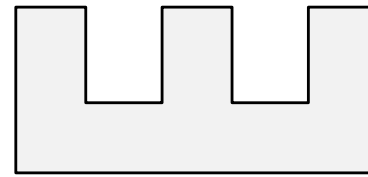
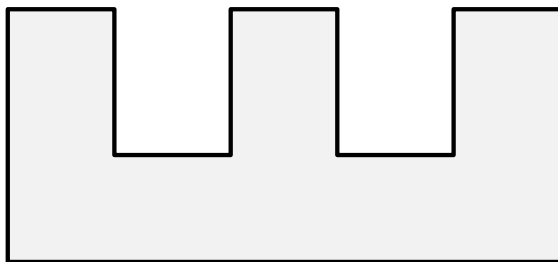
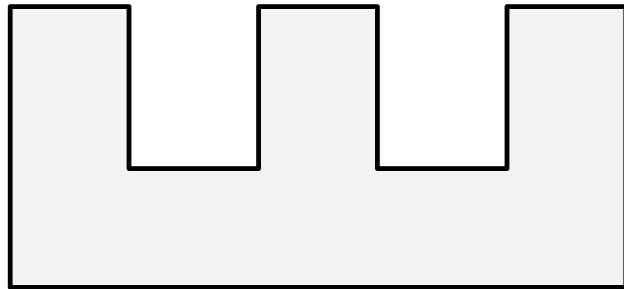
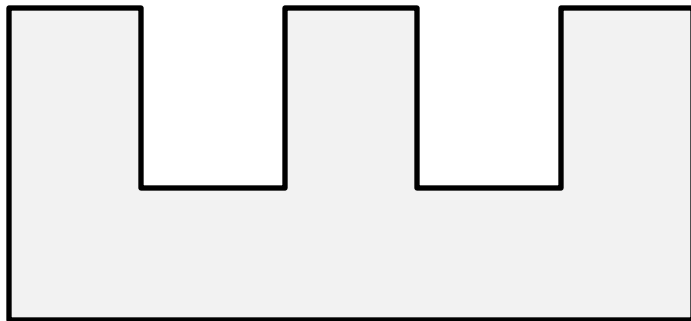

A circular or square stone building as might be found in a castle.

Default orientation: palewise. Proper coloration: argent or gray.

The battlements represent the crenelated peak of the tower.

Source: Commonplace Book of Heraldry. (Folio 15v.)

Artist: Jean Faucket. Adapted by Mathghamhain Ua Ruadháin.

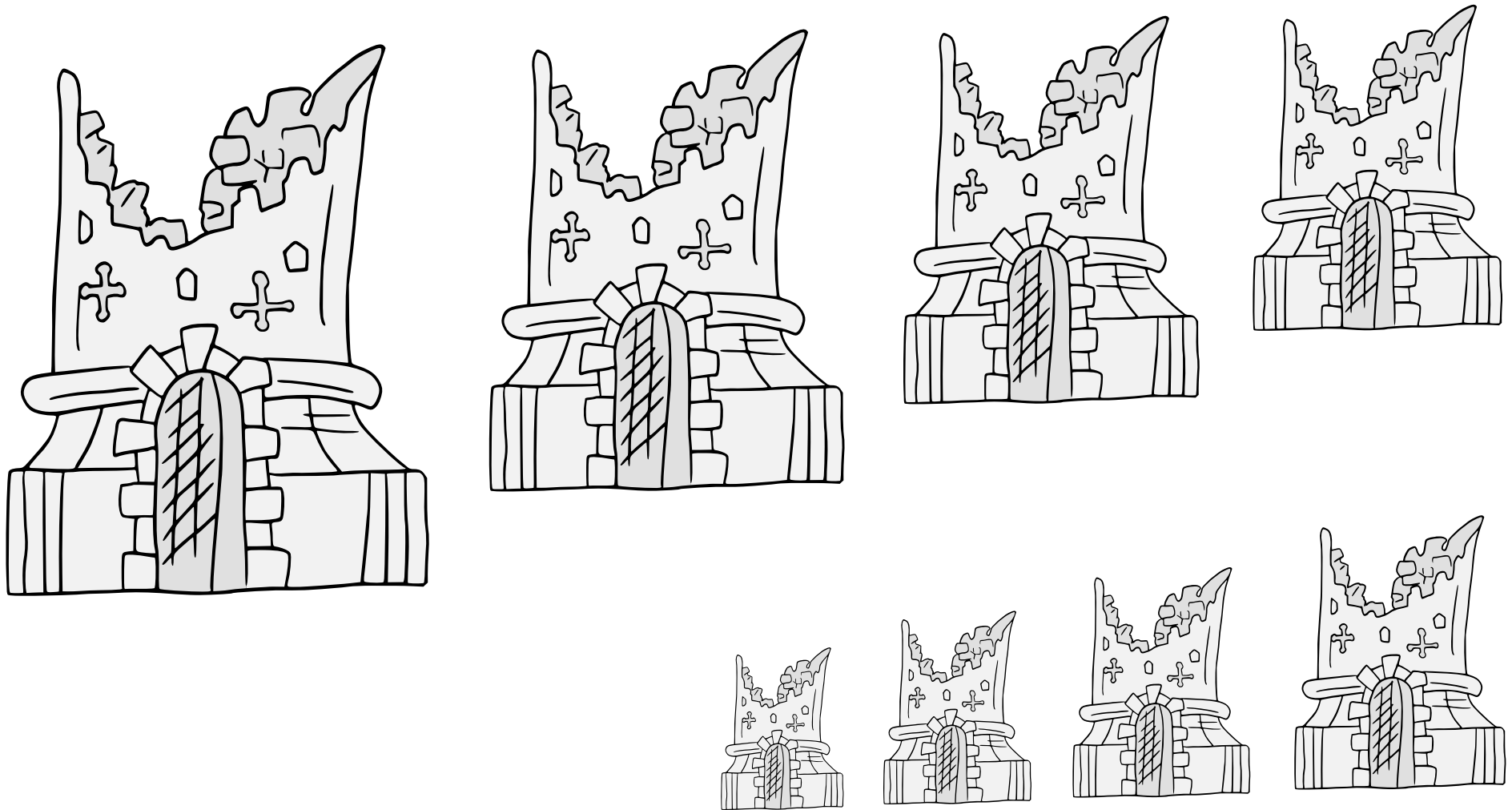

A circular or square stone building as might be found in a castle.

Default orientation: palewise. Proper coloration: argent or gray.

Source: Coats of Arms of Irish Families. Artist unknown.

Adapted by Malyss Makneile.

Tower, Broken 17.225

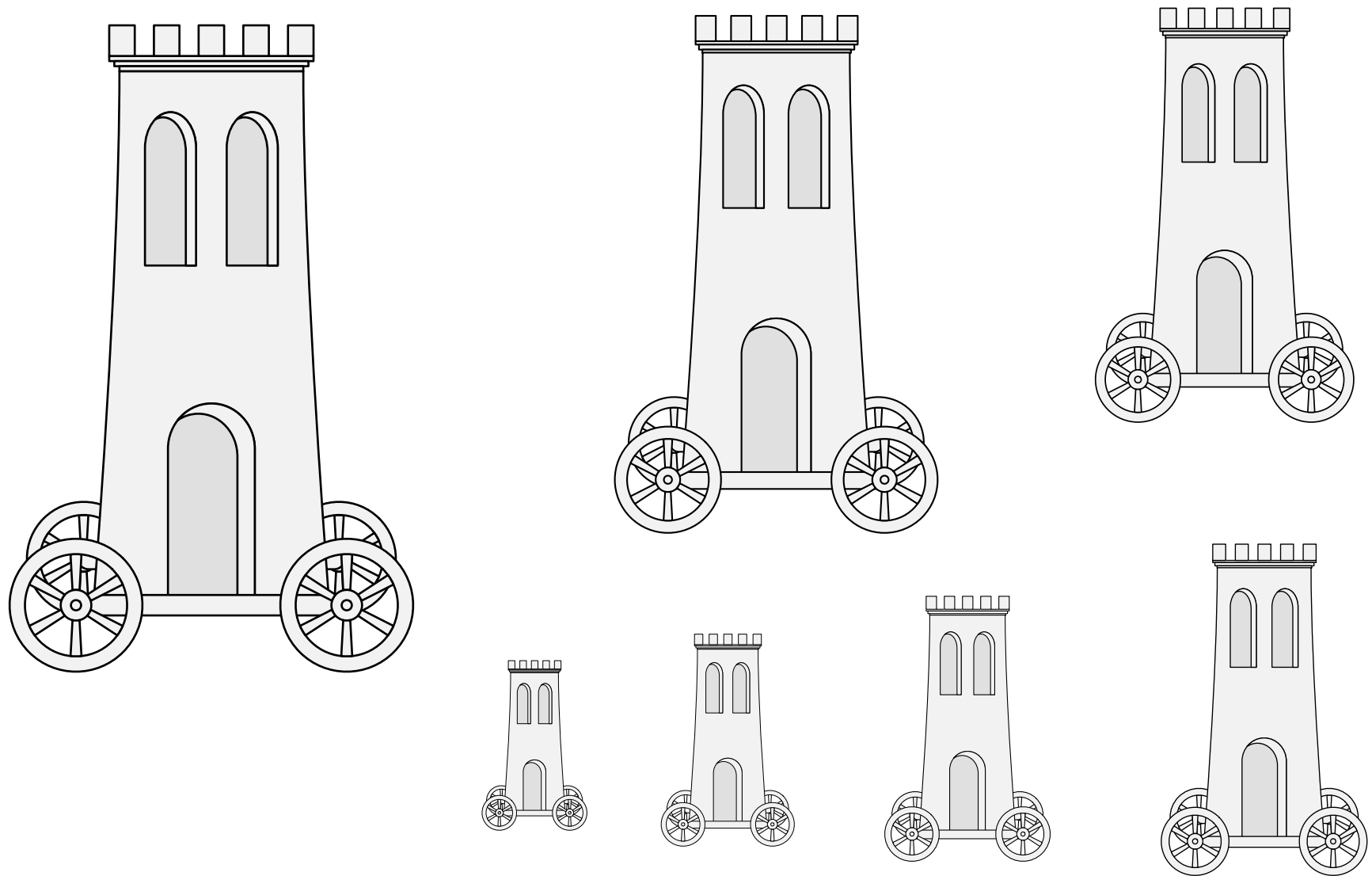

A circular or square stone building as might be found in a castle.

Default orientation: palewise. Proper coloration: argent or gray.

A siege tower rides on wheels so it may be pushed close to a wall.

Source: *Insignia Urbium Italiae Septentrionalis*. Artist: Unknown.
(Arms of de Branbano, folio 81r.)

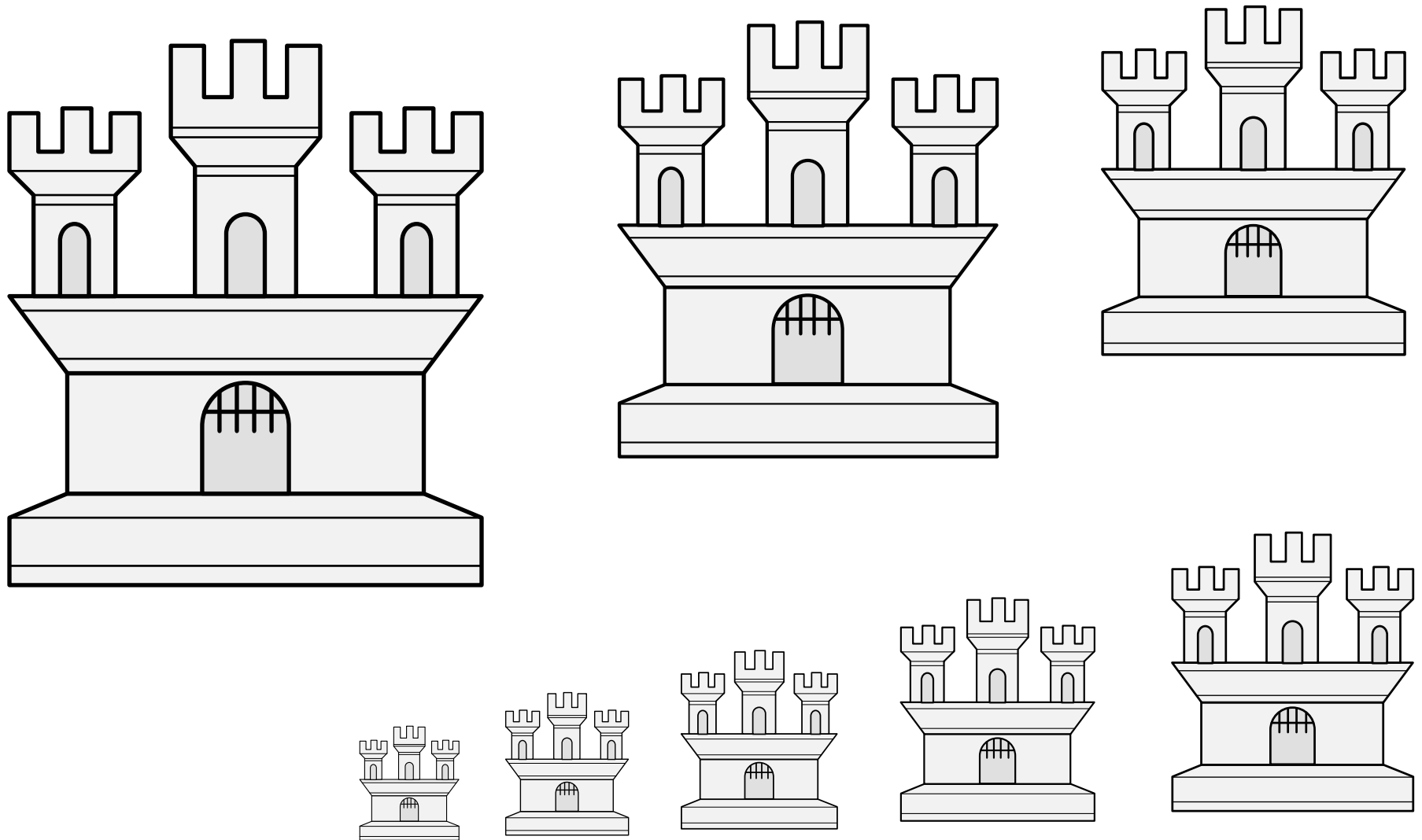

A circular or square stone building as might be found in a castle.

Default orientation: palewise. Proper coloration: argent or gray.

Source: Bellenville Armorial. Artist unknown. (Folio 5r.)

Tower Triple-Towered (1) 17.227

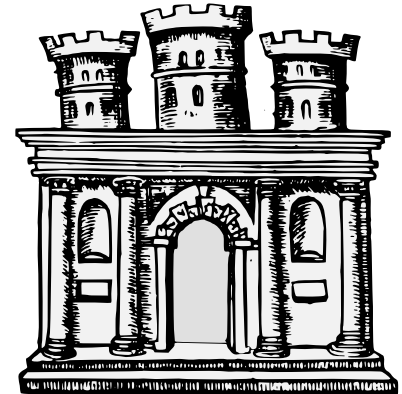
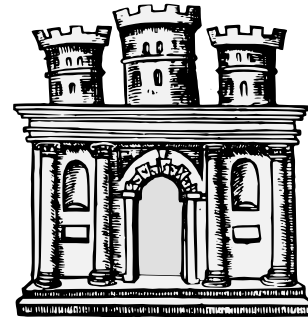
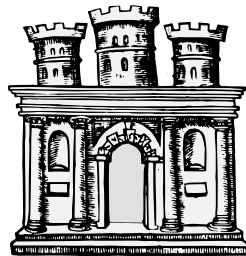
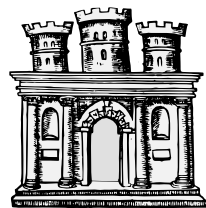
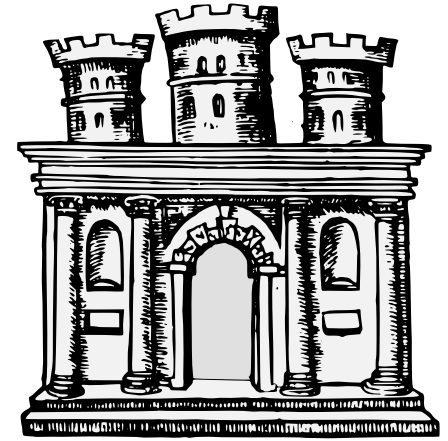
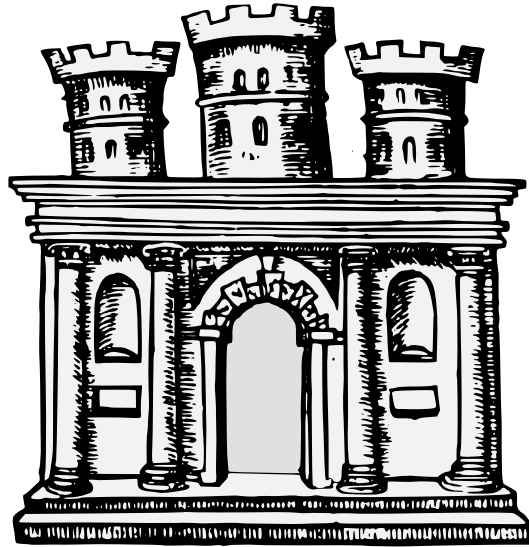
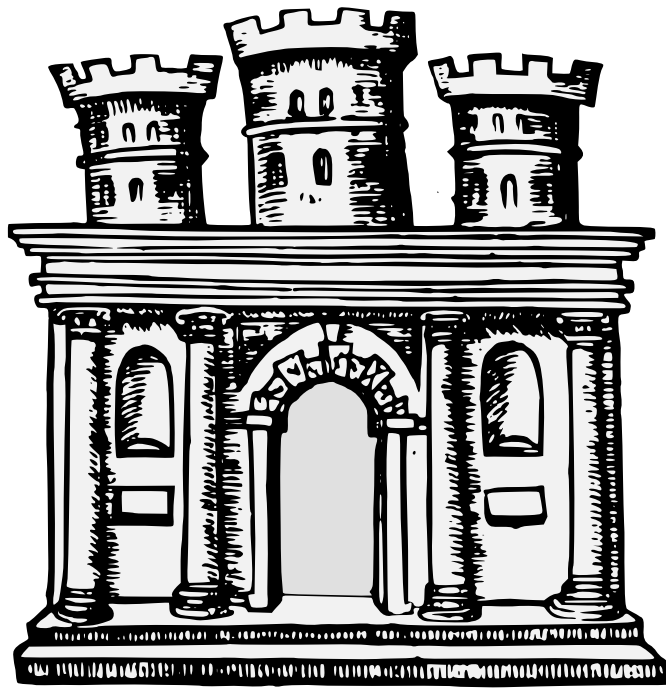

A circular or square stone building as might be found in a castle.

Default orientation: palewise. Proper coloration: argent or gray.

Source: Le Blason Des Armoiries.
Artist: Jérôme de Bara. (Page 157.)

Tower Triple-Towered (2) 17.228

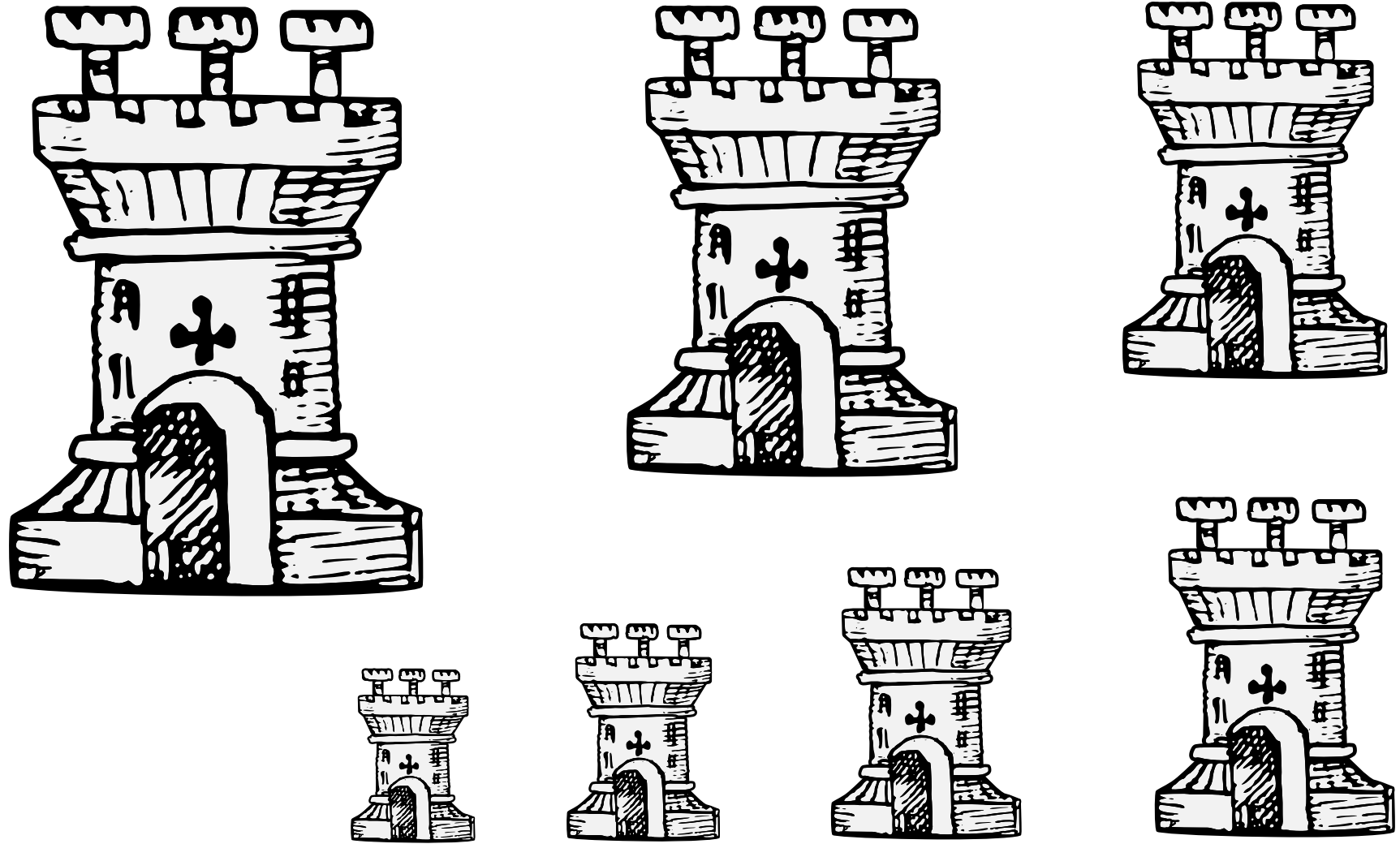

A circular or square stone building as might be found in a castle.

Default orientation: palewise. Proper coloration: argent or gray.

Source: Irish Nobility E1. Artist unknown.
(Folio 21, arms of the baron of Kyllen.)

Tower Triple-Towered (3) 17.229

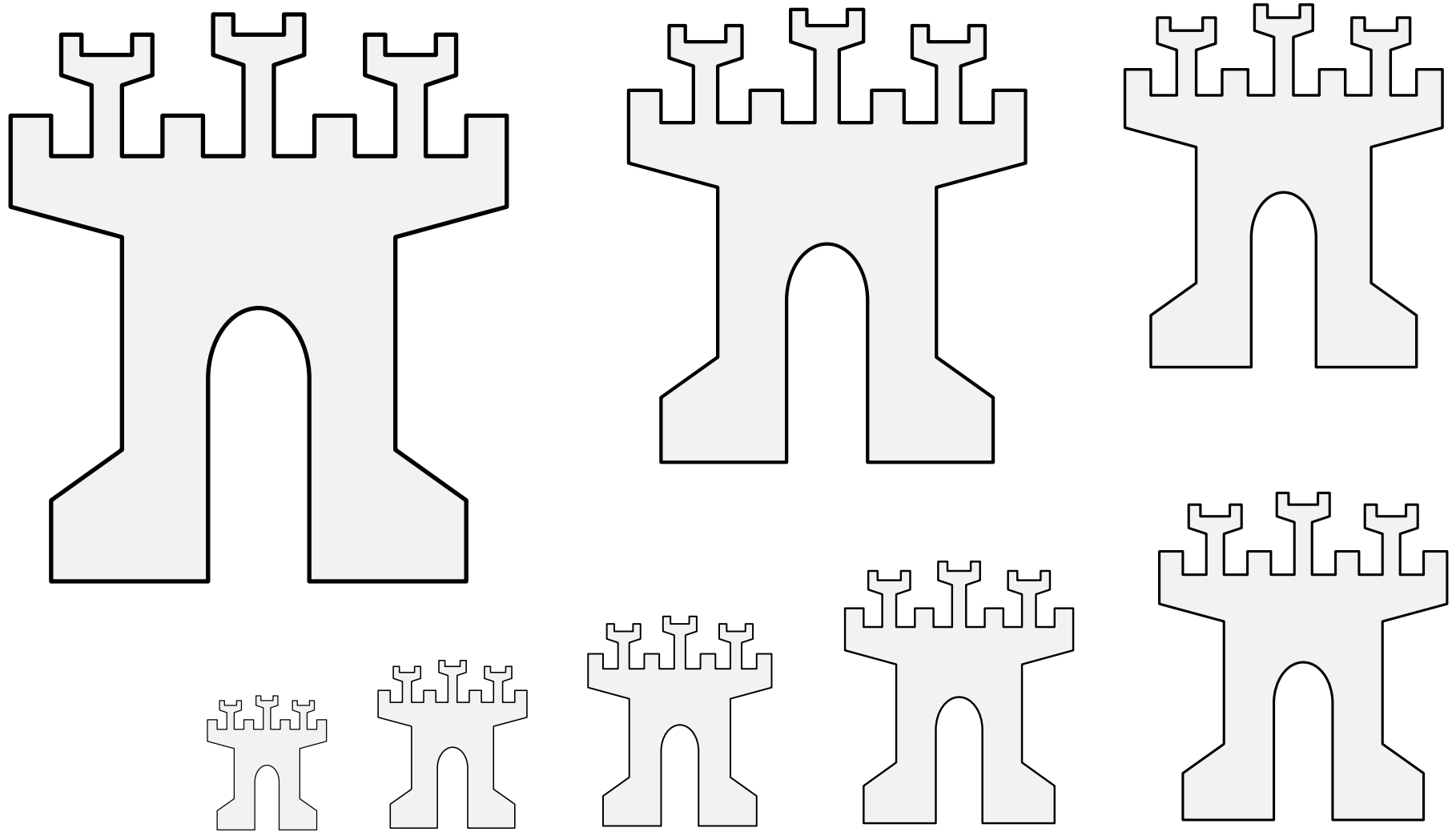

A circular or square stone building as might be found in a castle.

Default orientation: palewise. Proper coloration: argent or gray.

Source: Armorial dit de Lyncenich. Artist unknown.

Tower Triple-Towered (4) 17.230

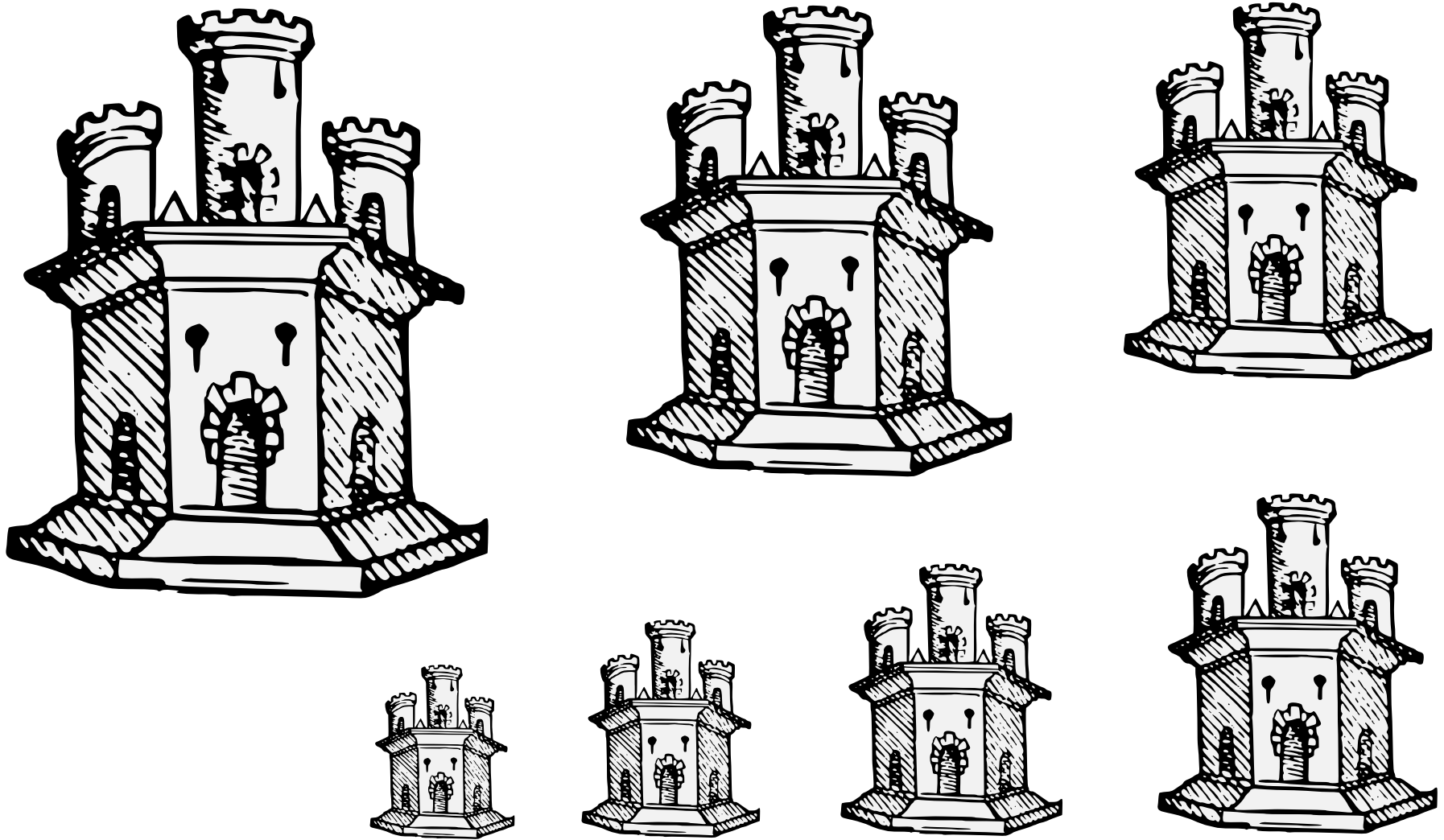

A circular or square stone building as might be found in a castle.

Default orientation: palewise. Proper coloration: argent or gray.

Source: Nobleza del Andaluzia. Artist unknown.
(Arms of Castilla, folio 33r.)

Tower Triple-Towered (5) 17.231

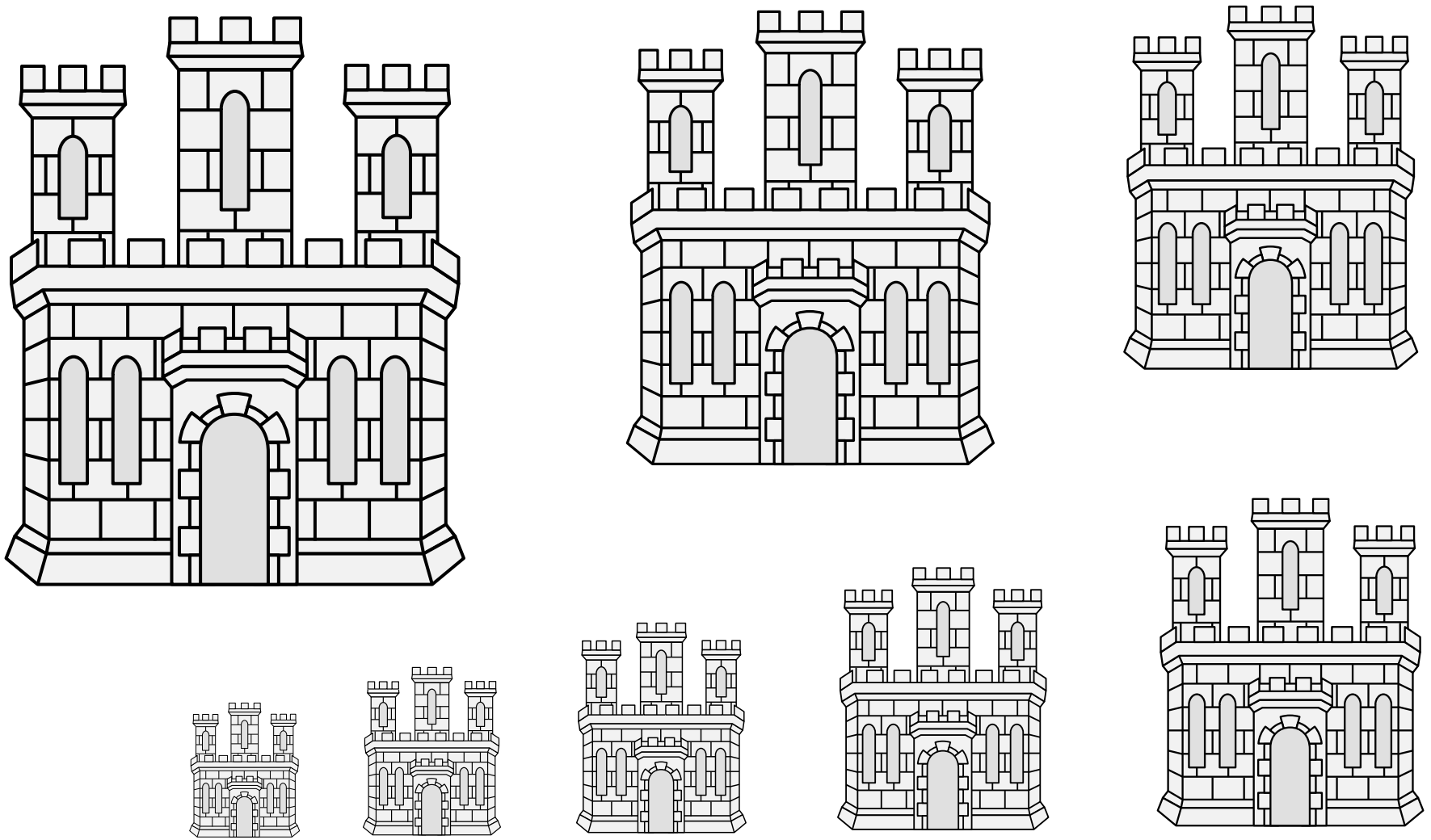

A circular or square stone building as might be found in a castle.

Default orientation: palewise. Proper coloration: argent or gray.

Source: WappenWiki. Artist: Joakim Spuller.

Tower Triple-Towered (6) 17.232

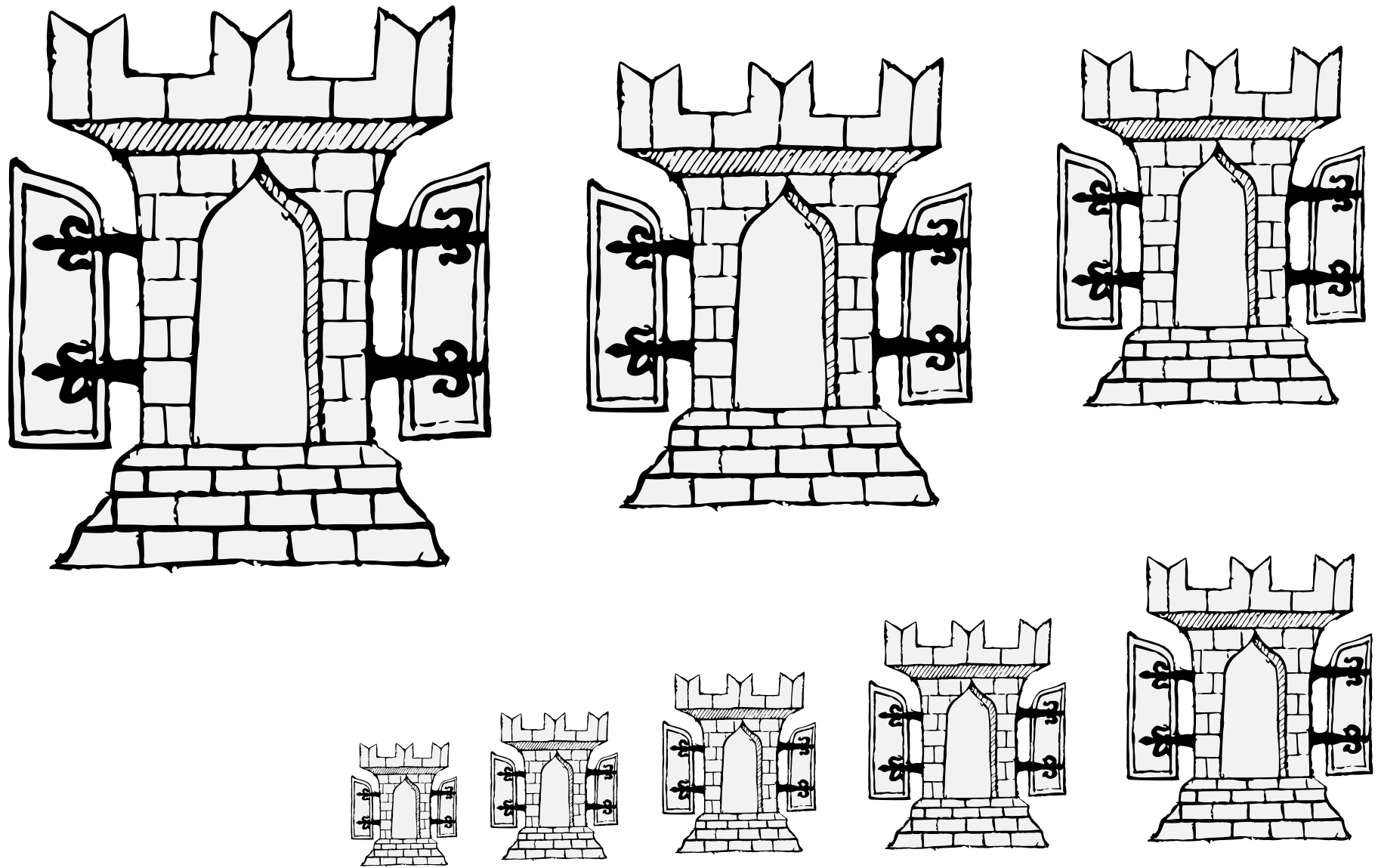

A circular or square stone building as might be found in a castle.

Default orientation: palewise. Proper coloration: argent or gray.

Source: Scheibler Armorial. Artist: Unknown.

(From the arms of von Niderthor.)

Tower With Open Doors 17.233

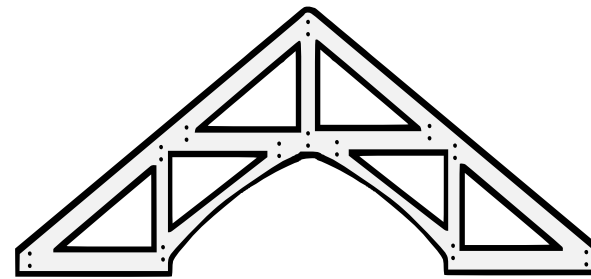
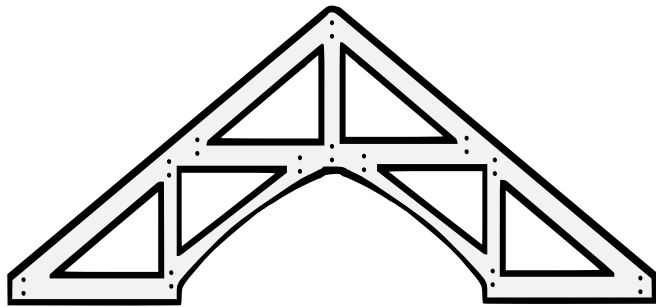
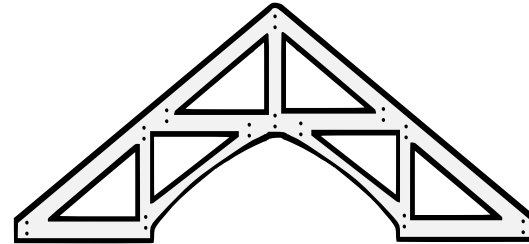
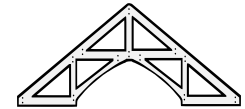
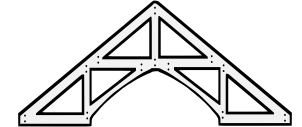
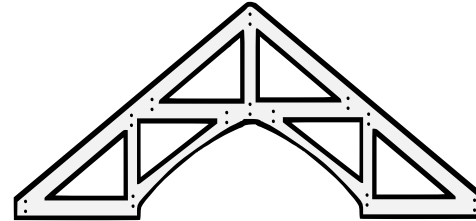
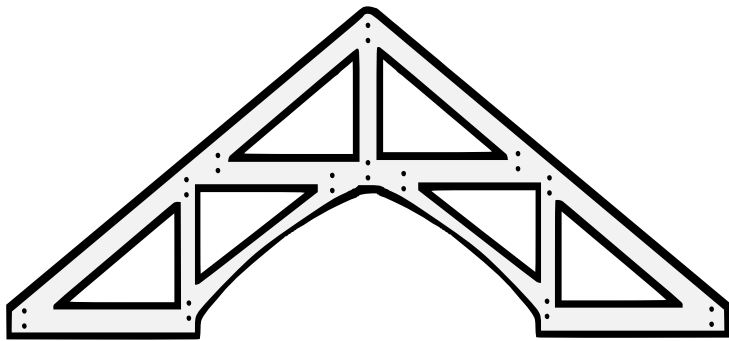
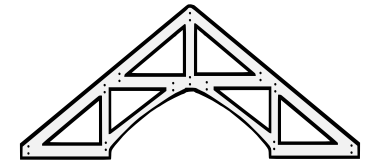
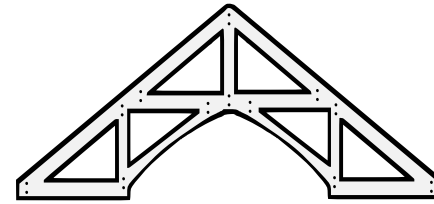
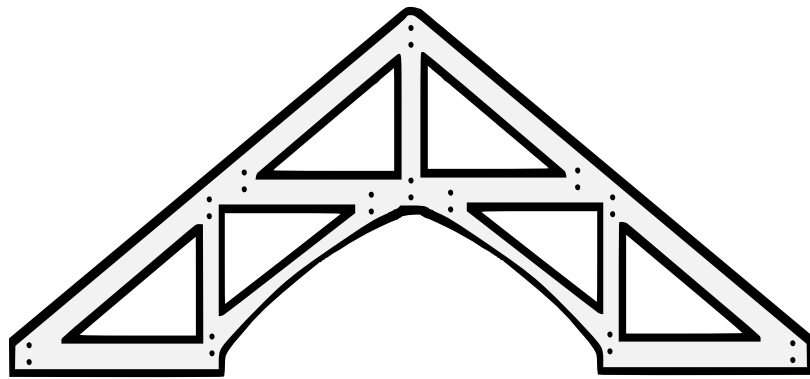

A cross-stabilized support element.

This charge has not yet been registered.

Default orientation: chevronwise. No proper coloration.

Artist: Jessimond of Emerickeskepe.

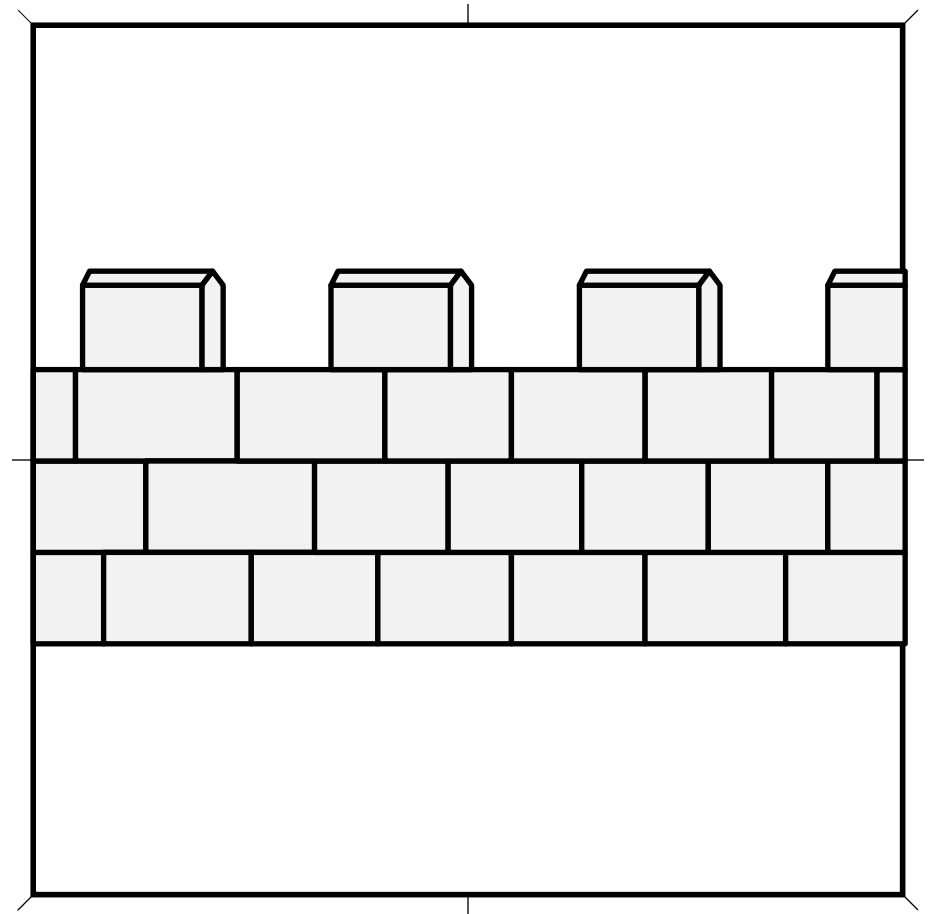
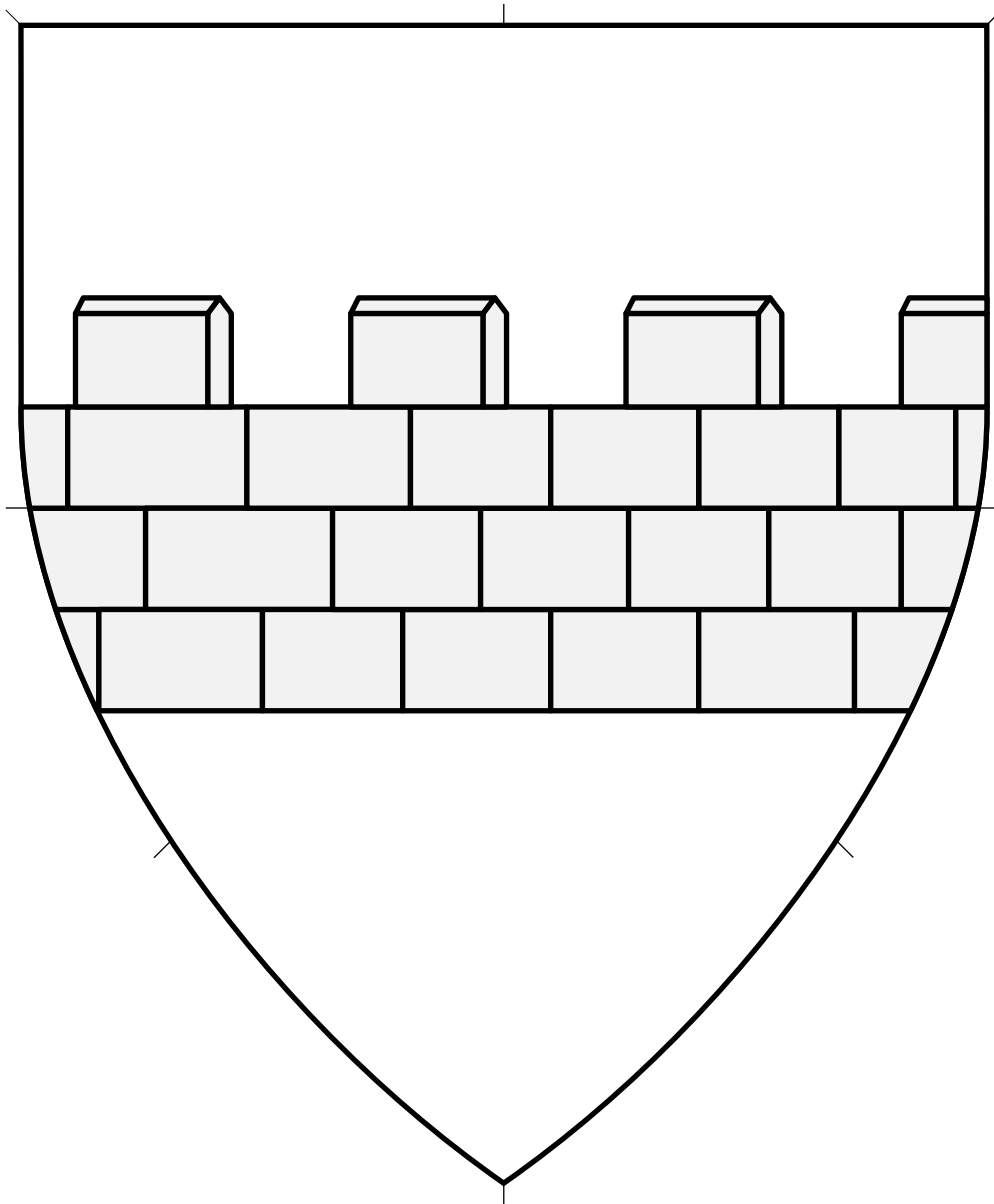

A barrier of stone.

Default orientation: fesswise throughout. Proper coloration: gray or argent stone.

Source: Catalogue des Très Illustres Grands-Maistres de France.

Artist unknown. (Folio 3r.)

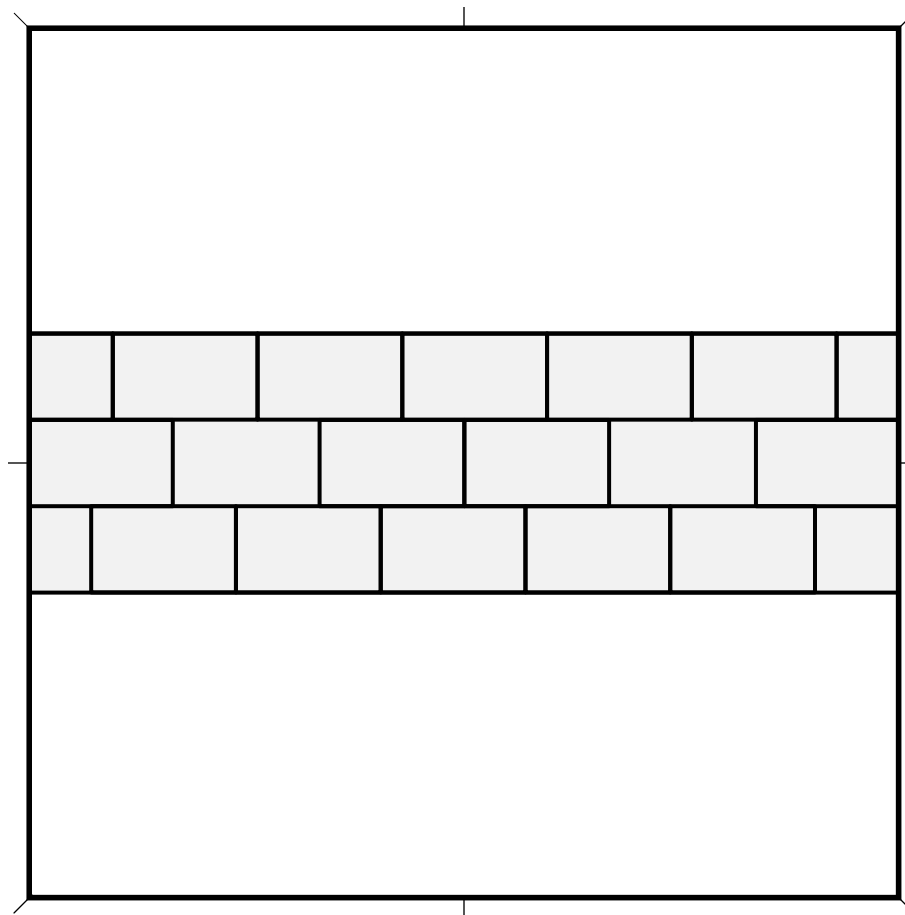
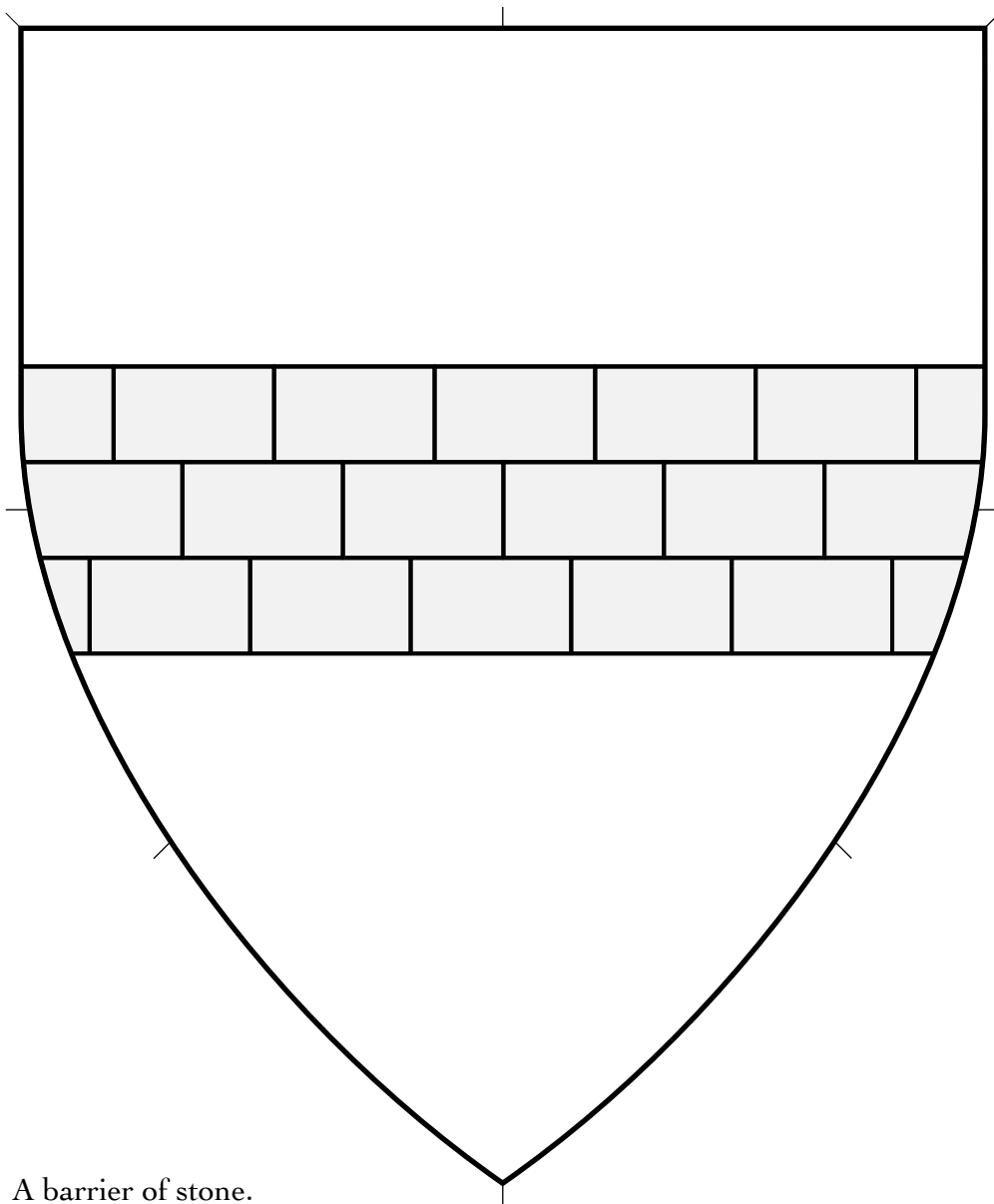

A barrier of stone.

Default orientation: fesswise throughout. Proper coloration: gray or argent stone.

Source: Insignia Veneta, Mantuana, Bononiensia, Anconitana, Urbinatia, Perugiensia.

Artist unknown. (From the arms of Tiepolli, folio 79).

Adapted by Mathghamhain Ua Ruadháin.

Wall Unembattled 17.236

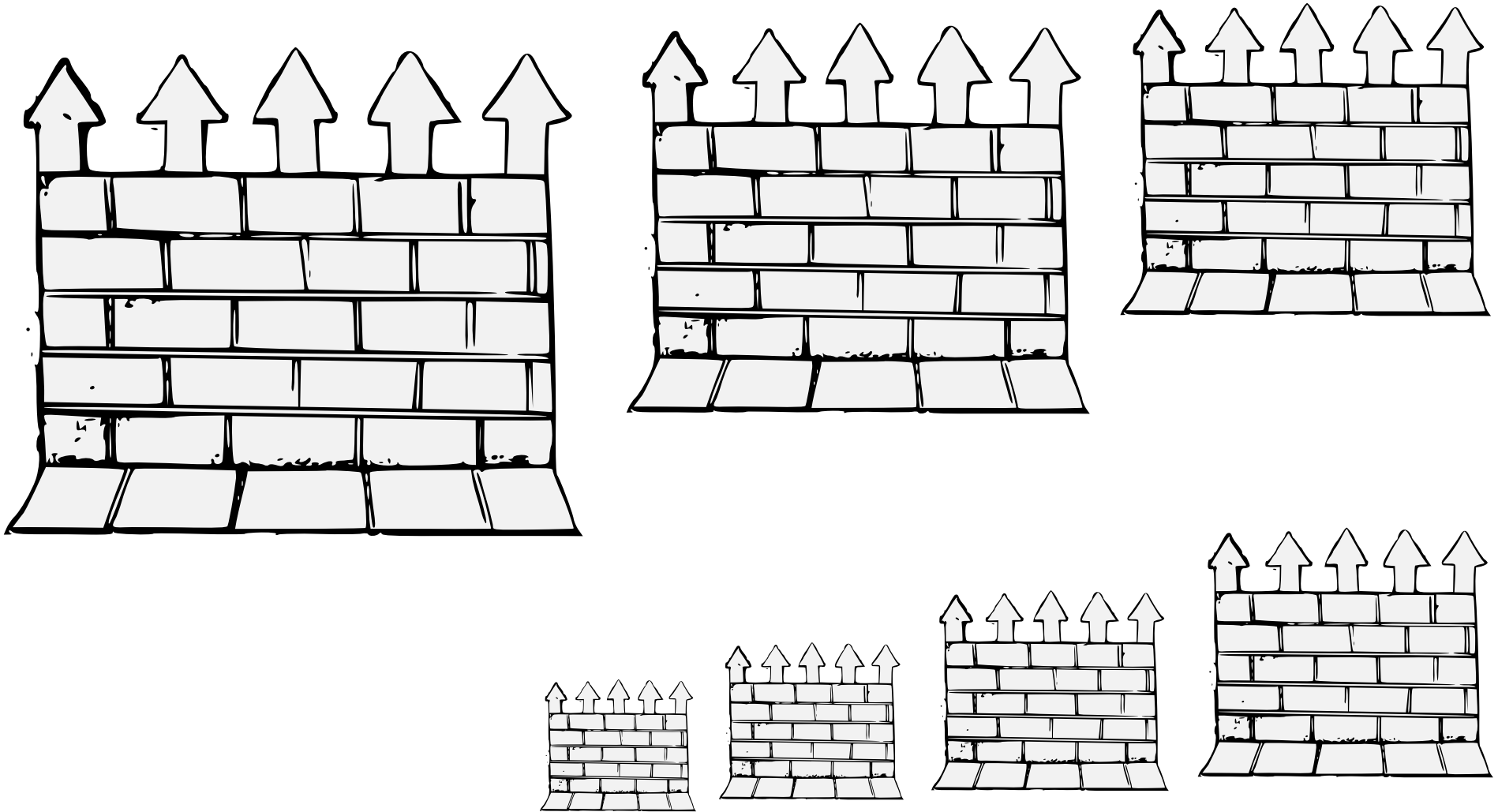

A barrier of stone.

Default orientation: fesswise throughout. Proper coloration: gray or argent stone.

Source: Armas de los Condes. Artist unknown.

Wall Couped 17.237

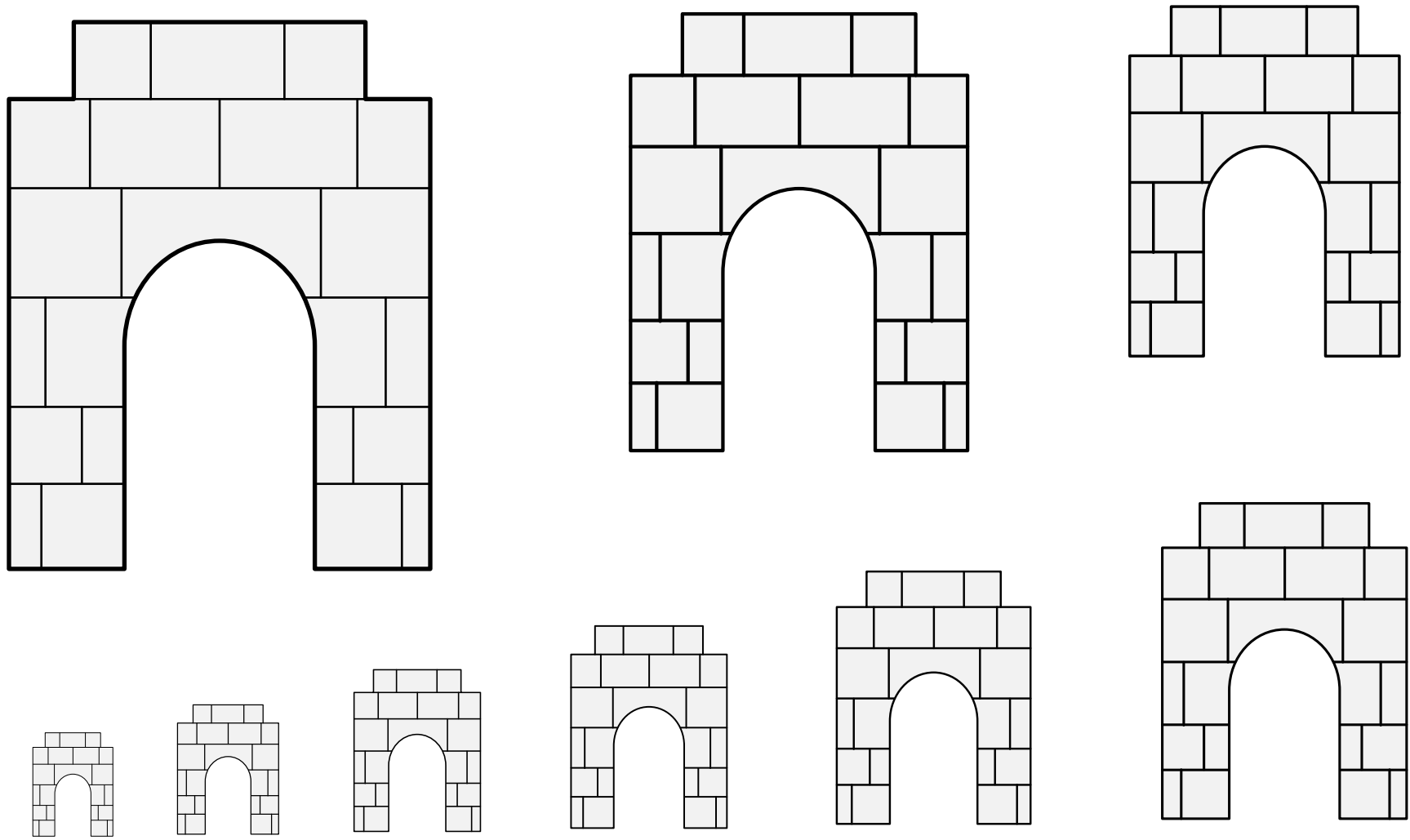

A barrier of stone.

Default orientation: fesswise throughout. Proper coloration: gray or argent stone.

Source: Libro de Armas y Blasones de Diversos Linajes y Retratos. Artist unknown. (Folio 77v.)

Wall Couped with An Arched Doorway (1) 17.238

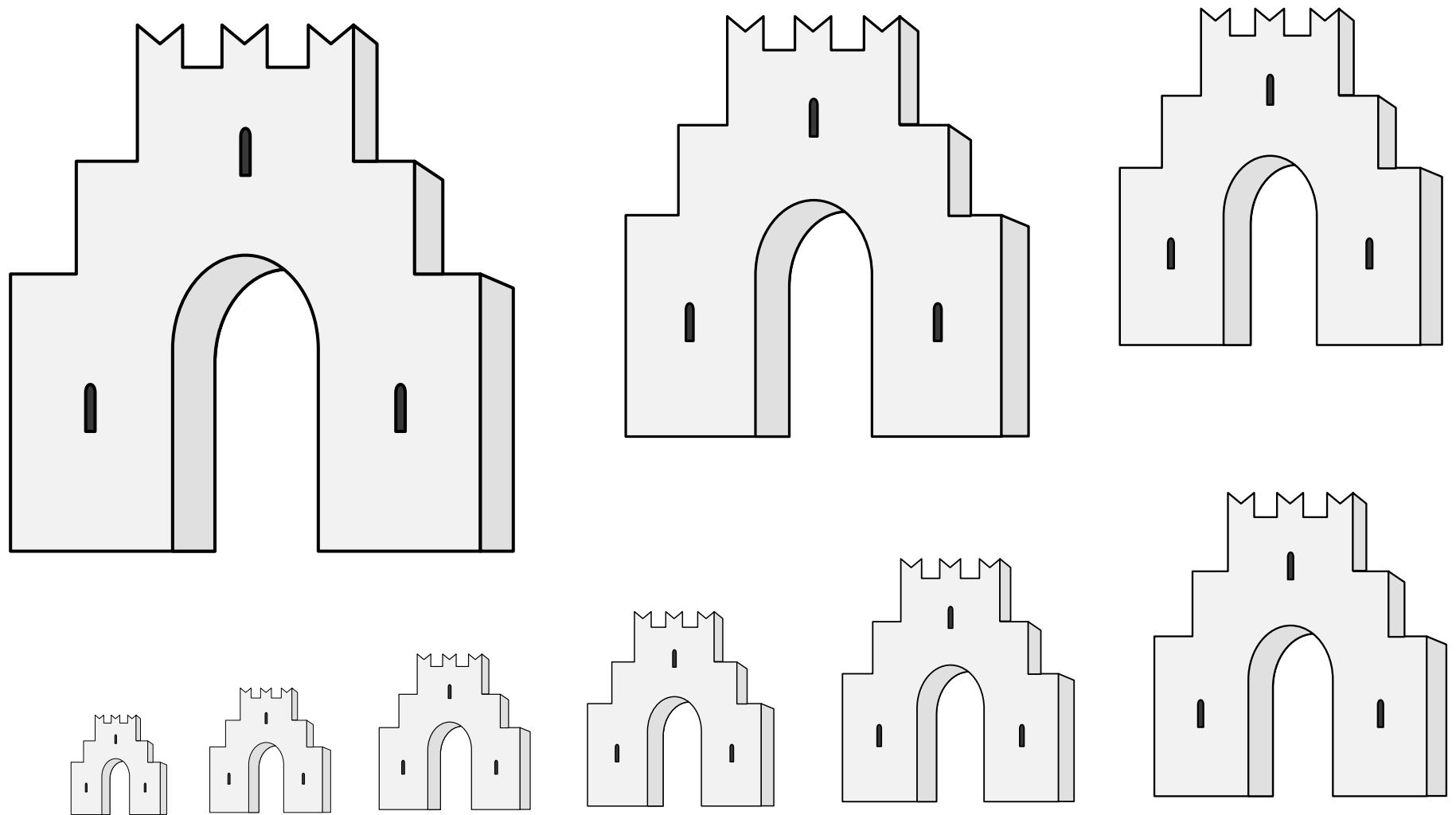

A barrier of stone.

Default orientation: fesswise throughout. Proper coloration: gray or argent stone.

Source: Wappenbuch der Arlberg-Bruderschaft. Artist: Vigil Raber. (Page 828.)

Wall Couped with An Arched Doorway (2) 17.239

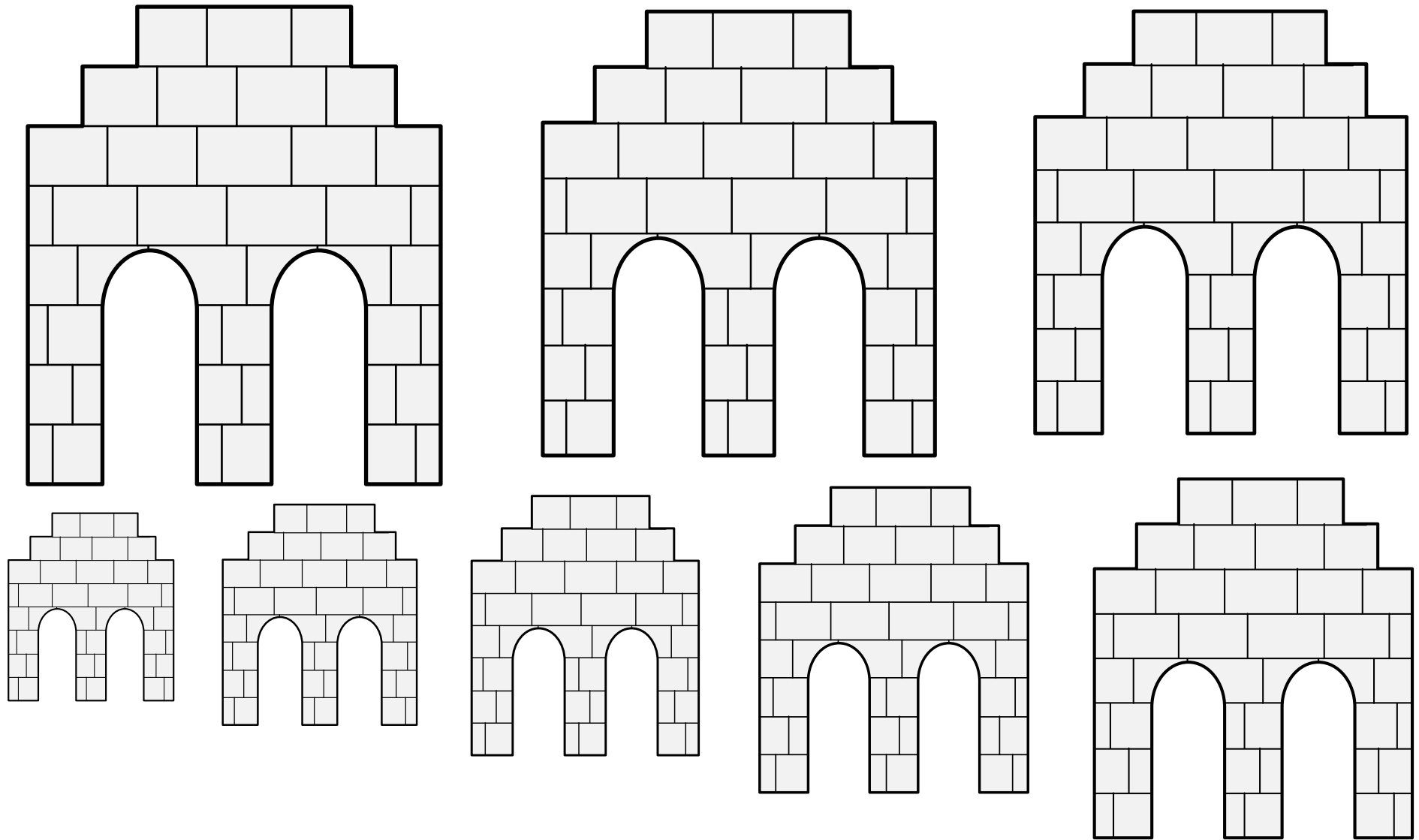

A barrier of stone.

Default orientation: fesswise throughout. Proper coloration: gray or argent stone.

Source: Libro de Armas y Blasones de Diversos Linajes y Retratos. Artist unknown. (Folio 76v.)

Wall Couped with Two Arched Doorways 17.240

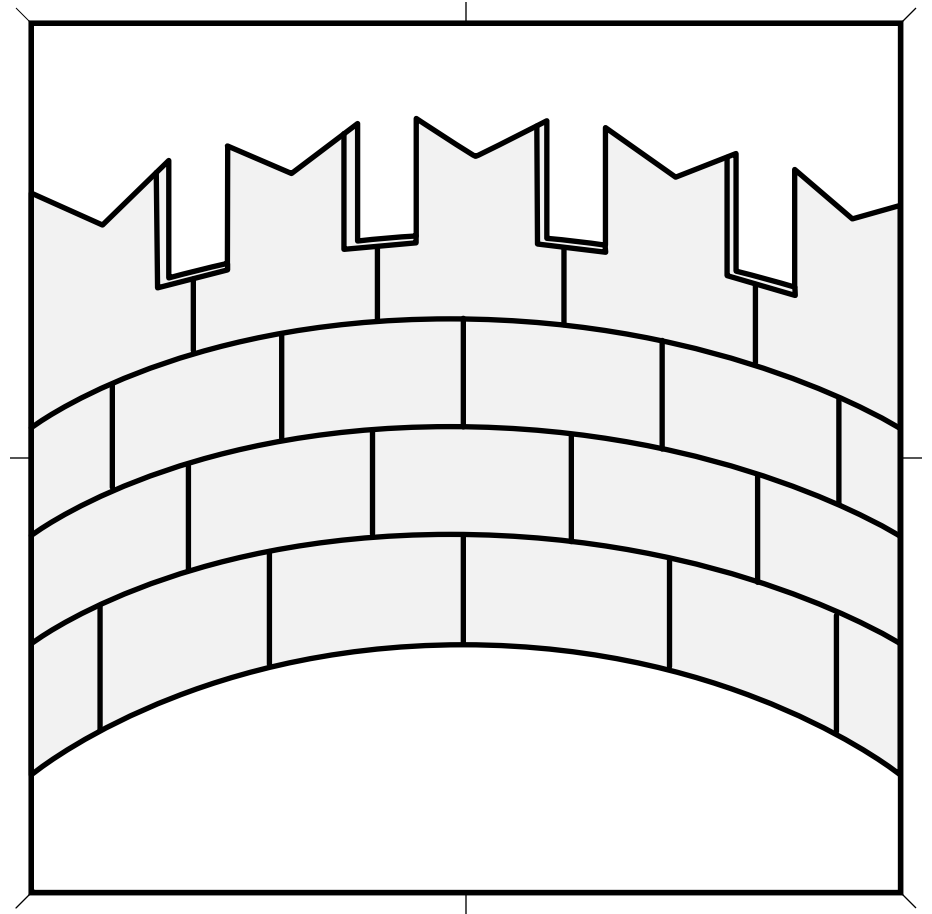
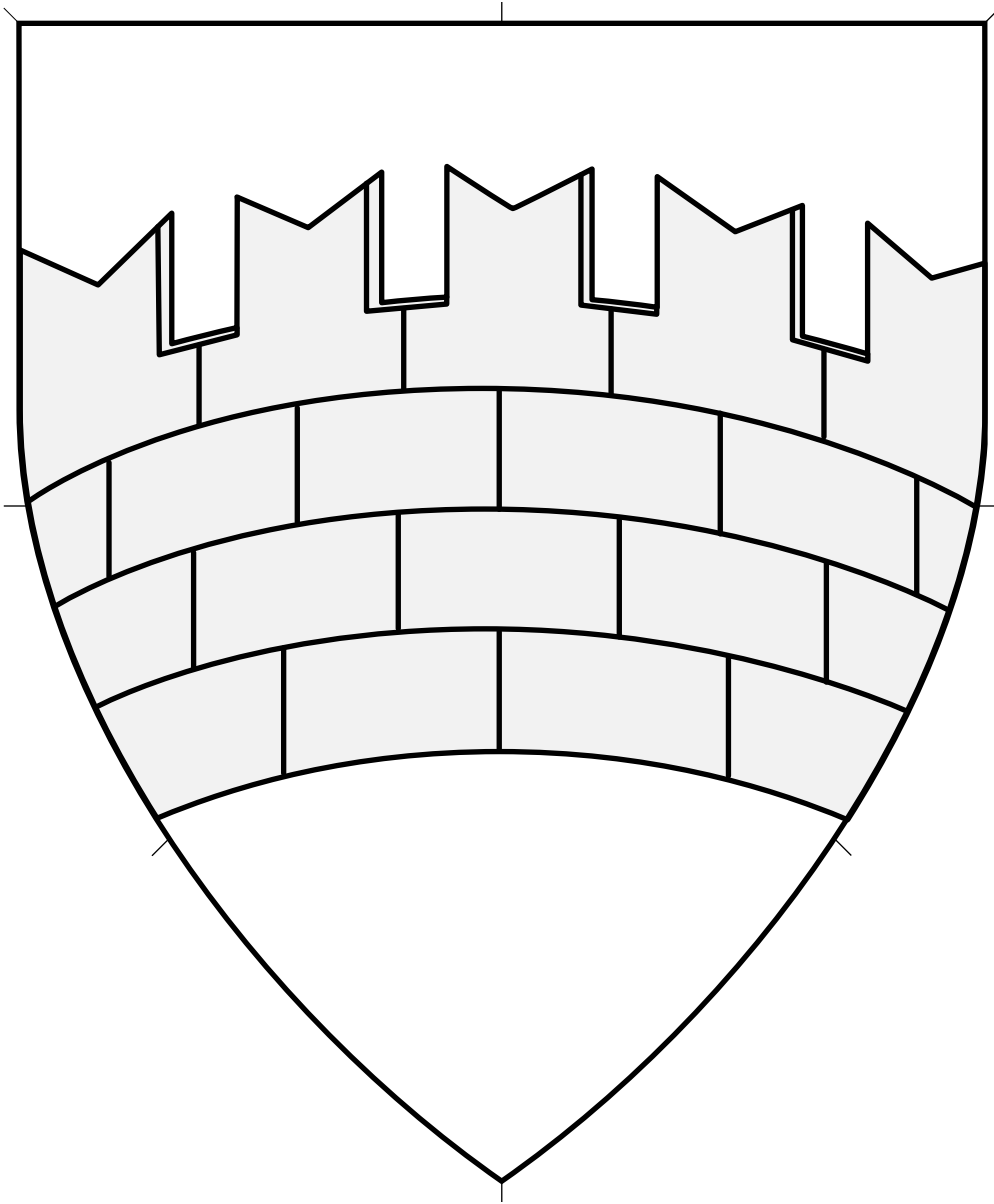

A barrier of stone.

Default orientation: fesswise throughout. Proper coloration: gray or argent stone.

Source: Scheibler Armorial. Artist: Unknown. (From the arms of von Weineckh.)
Adapted by Mathghamhain Ua Ruadháin.

Wall Enarched 17.241

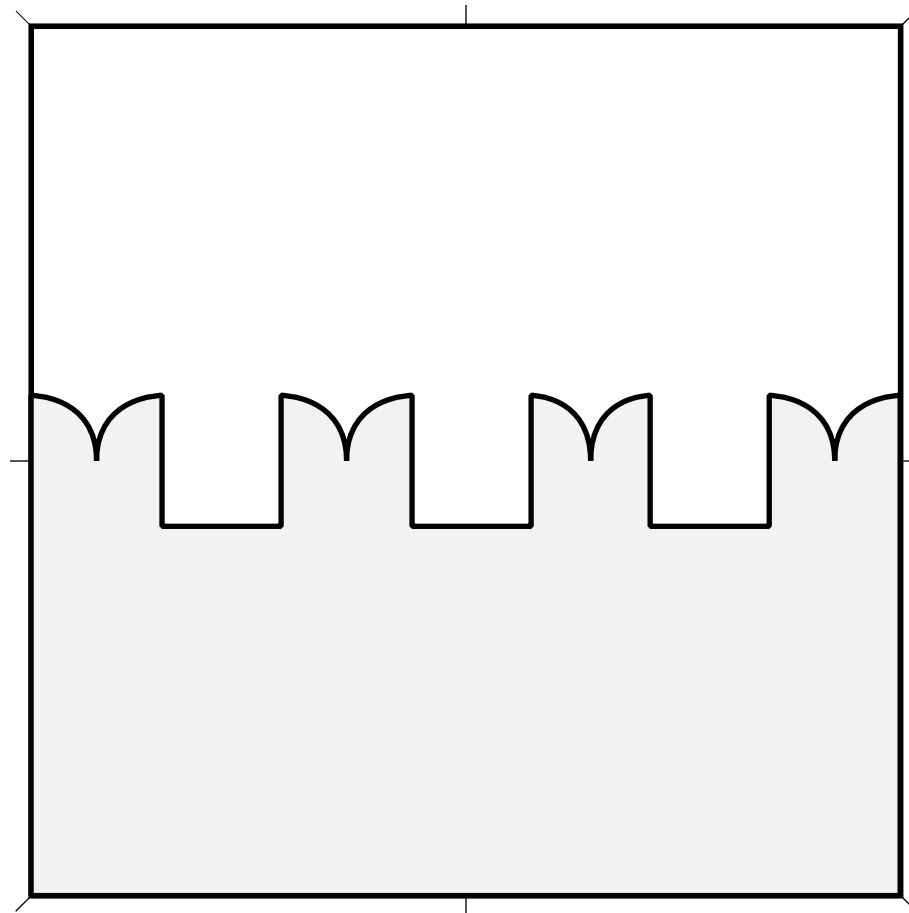
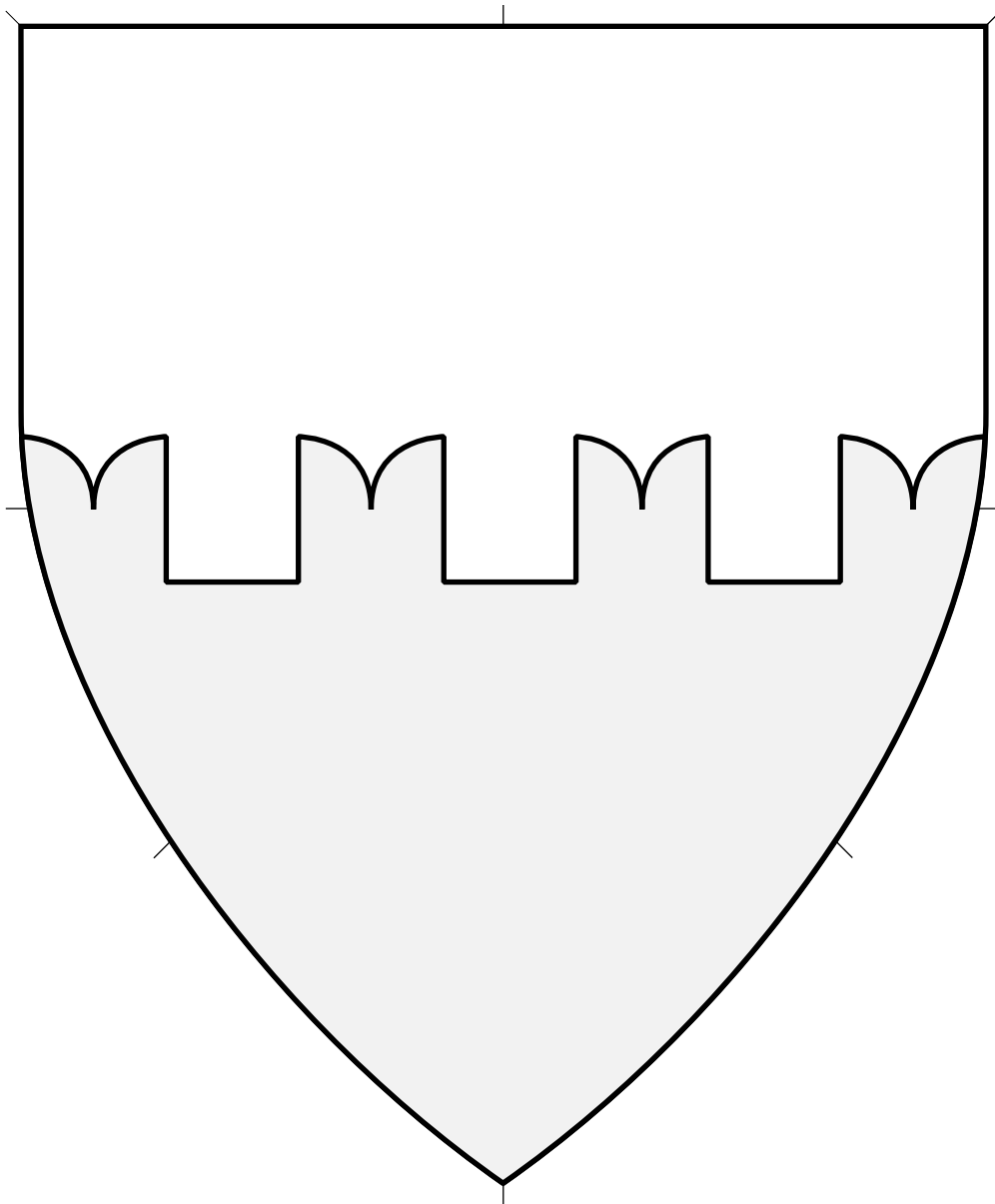

Default orientation: upright. Proper coloration: gray or argent stone.

Source: Stemmario Trivulziano.

Artist: Gian Antonio da Tradate. (Page 259.)

Wall Issuant From Base 17.242

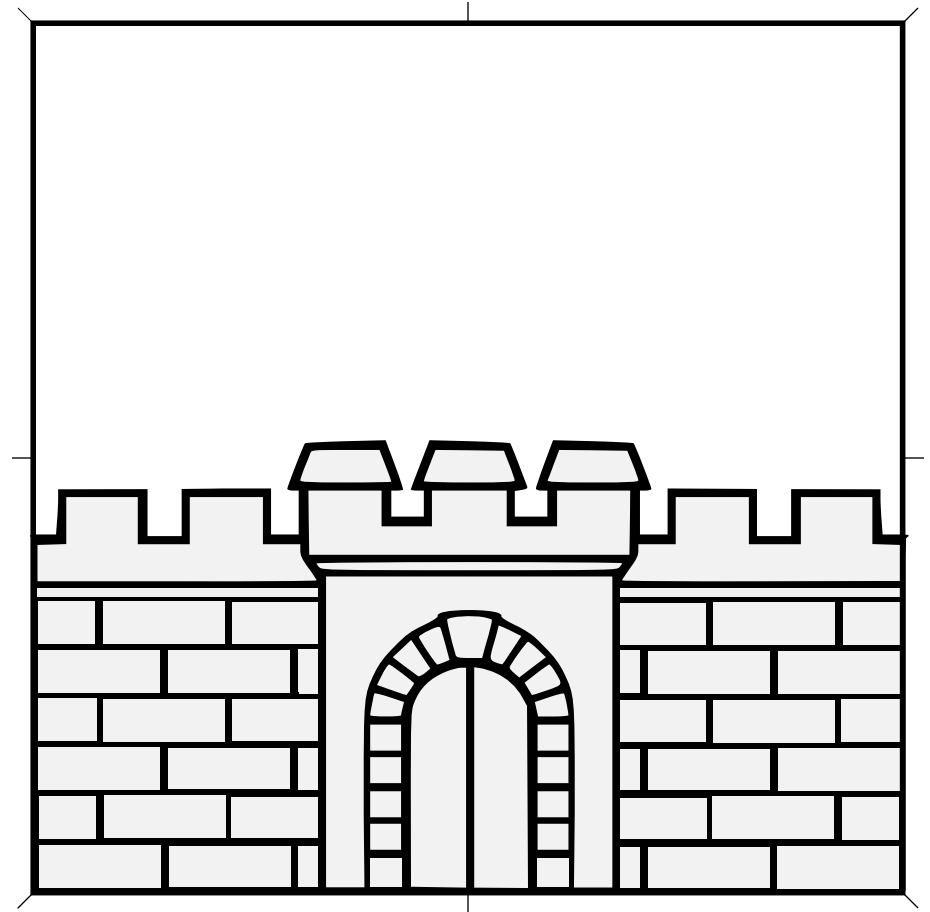
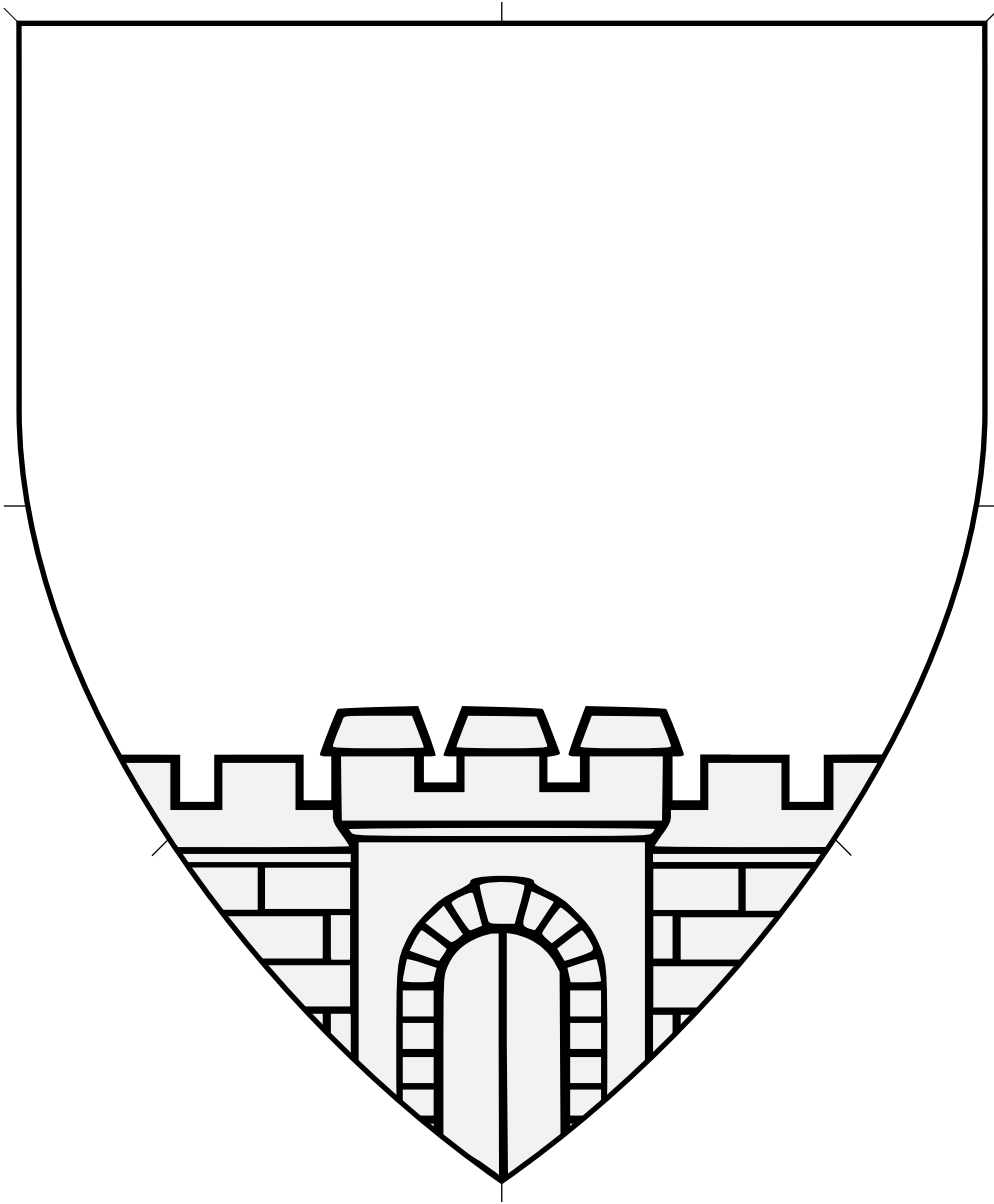

Default orientation: upright. Proper coloration: gray or argent stone.

Source: Wappen und Siegel des Kreises Alfeld.

Artist: Gustav Völker.

Adapted by Mathghamhain Ua Ruadháin.

Wall Issuant From Base With Gate 17.243

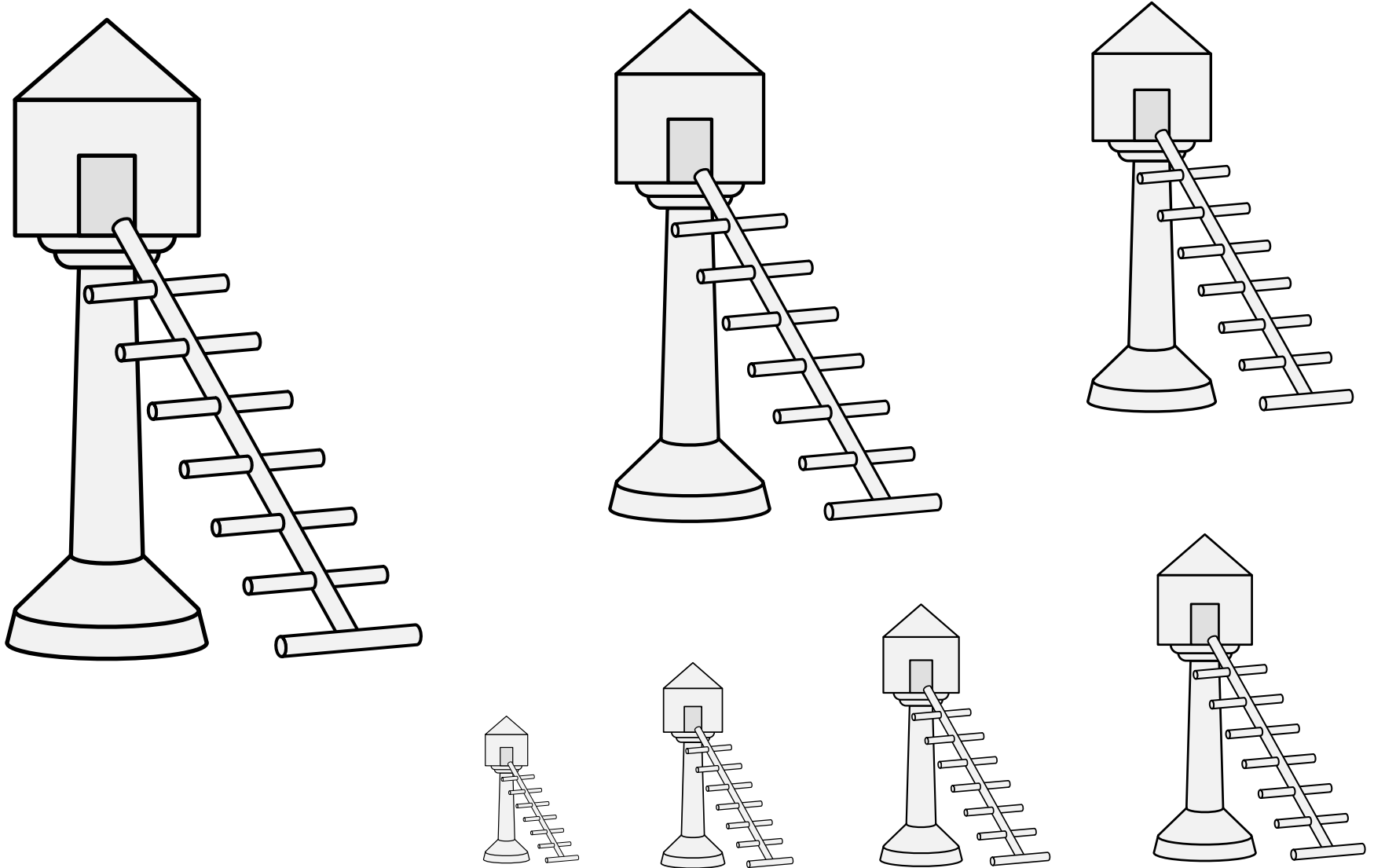

An elevated shelter accessible via a ladder.

Default orientation: upright. No proper coloration.

Source: Neustifter Wappenbuch. Artist: Vigil Raber.
(From the arms of Warthausen, page 134.)

Watchtower 17.244

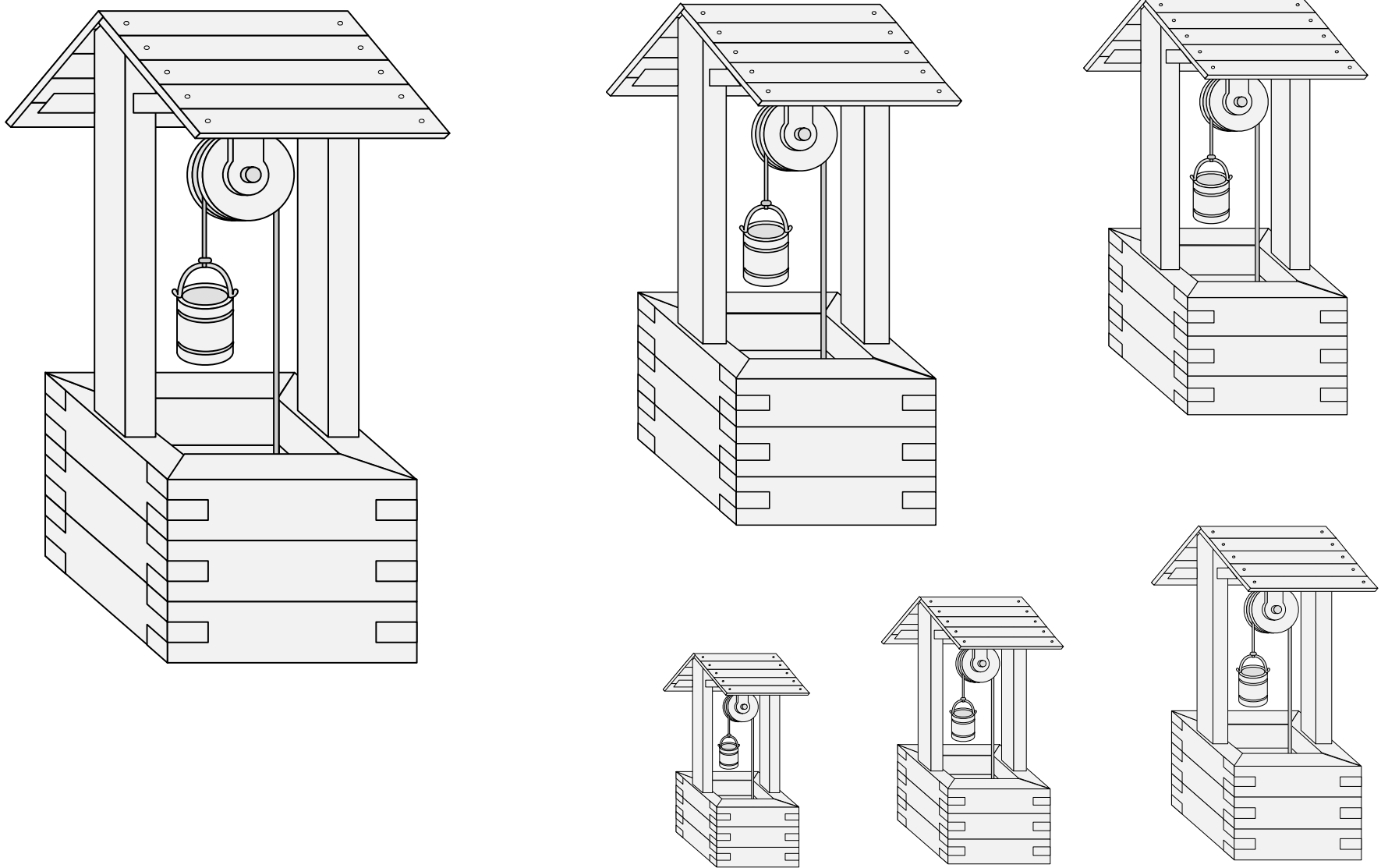

A water source enclosed by a short protective wall.

Default orientation: opening to chief. Proper coloration: gray or argent stone.

Adapted from Pierpont Morgan Library's MS M.763. Artist unknown.
(Folio 150v in a late 15th C. Austrian edition of Hugo von Trimberg's *Der Renner*.)

Well, Covered (1) 17.245

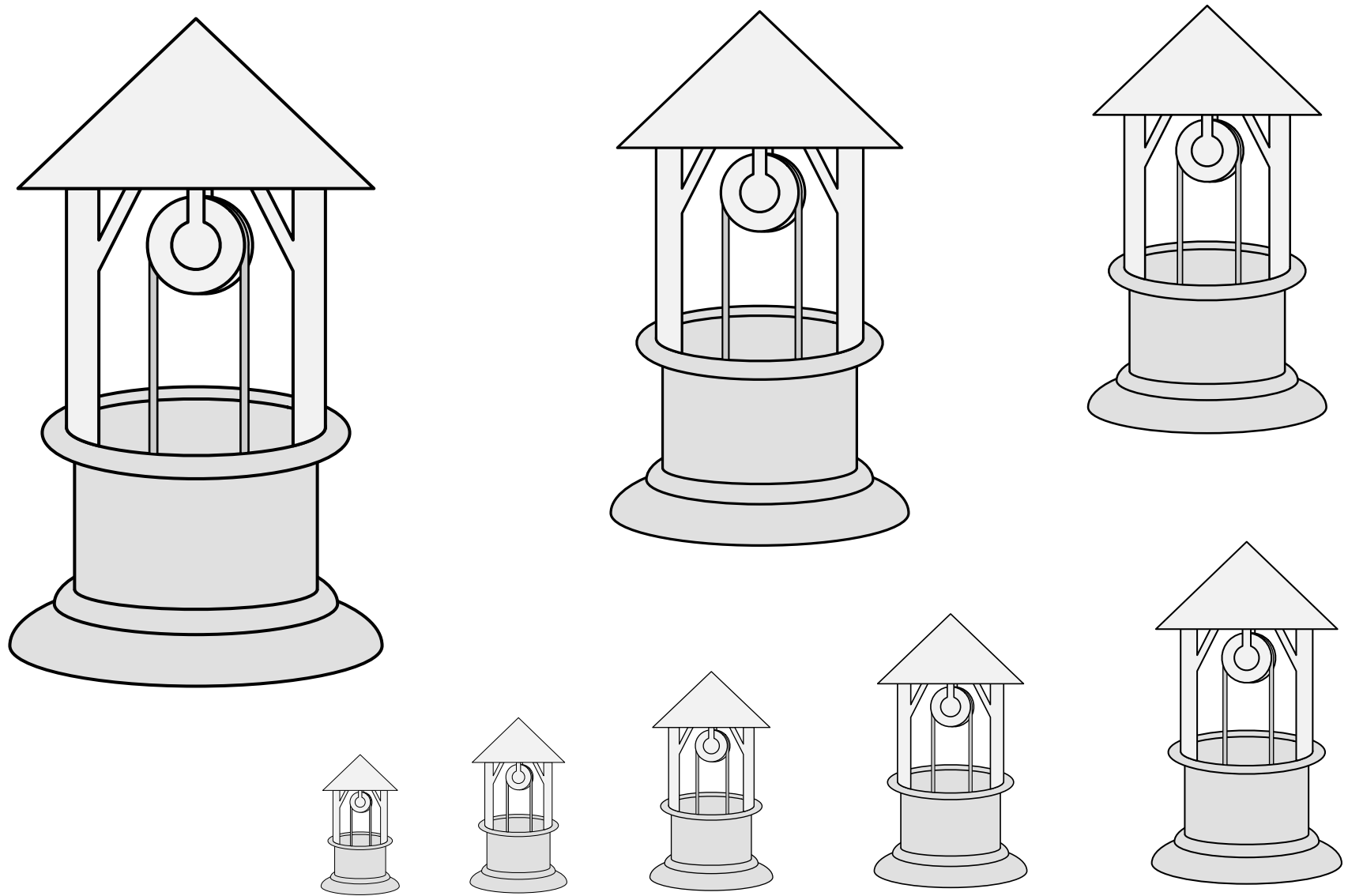

A water source enclosed by a short protective wall.

Default orientation: opening to chief. Proper coloration: gray or argent stone.

Source: Wappenbuch Fol 223. (Folio 31r.) Artist unknown.
Adapted by Mathghamhain Ua Ruadháin.

Well, Covered (2) 17.246

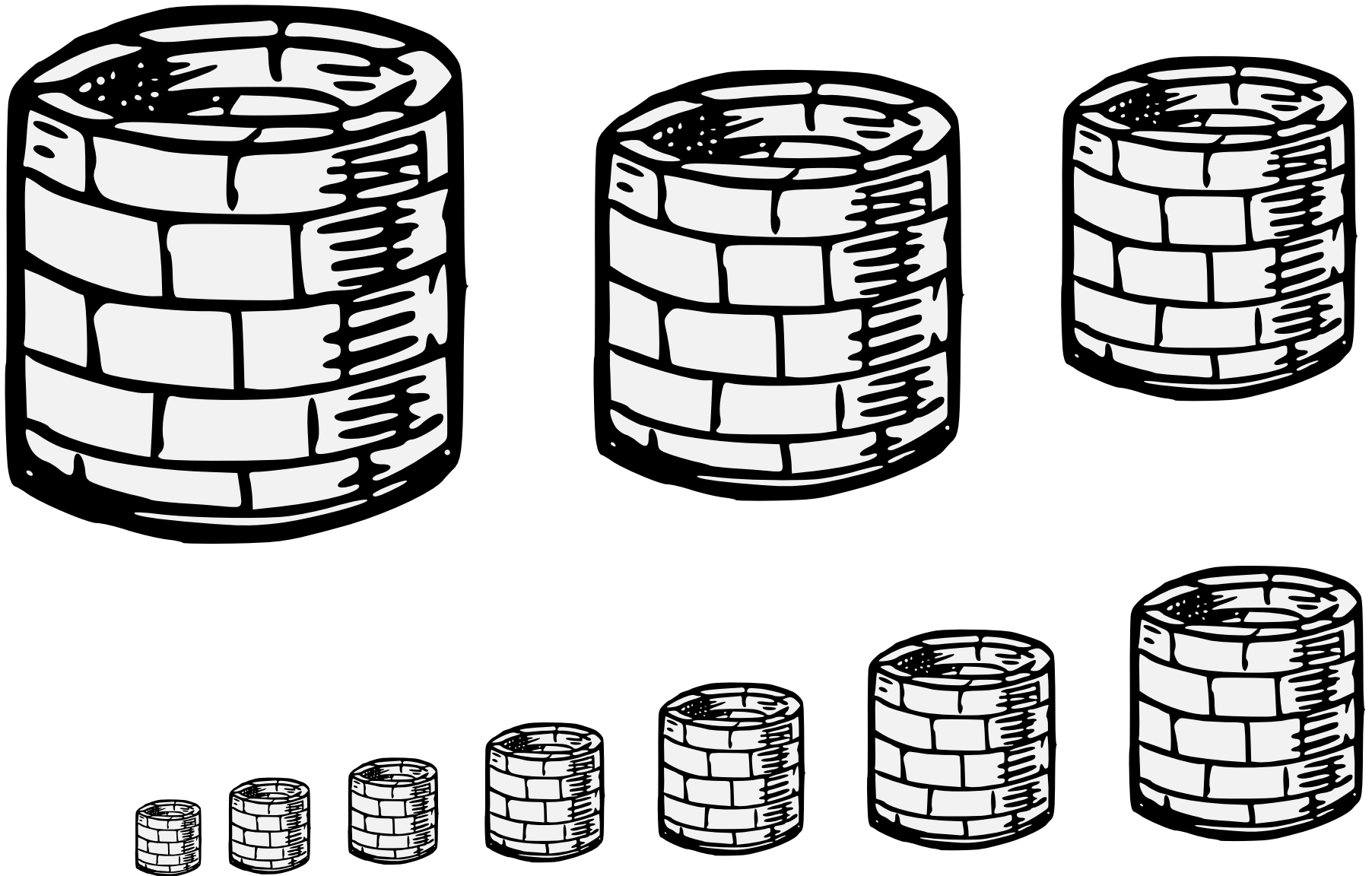

A water source enclosed by a short protective wall.
Default orientation: opening to chief. Proper coloration: gray or argent stone.
Source: The Art of Heraldry. Artist: Unknown.

Well, Open (1) 17.247

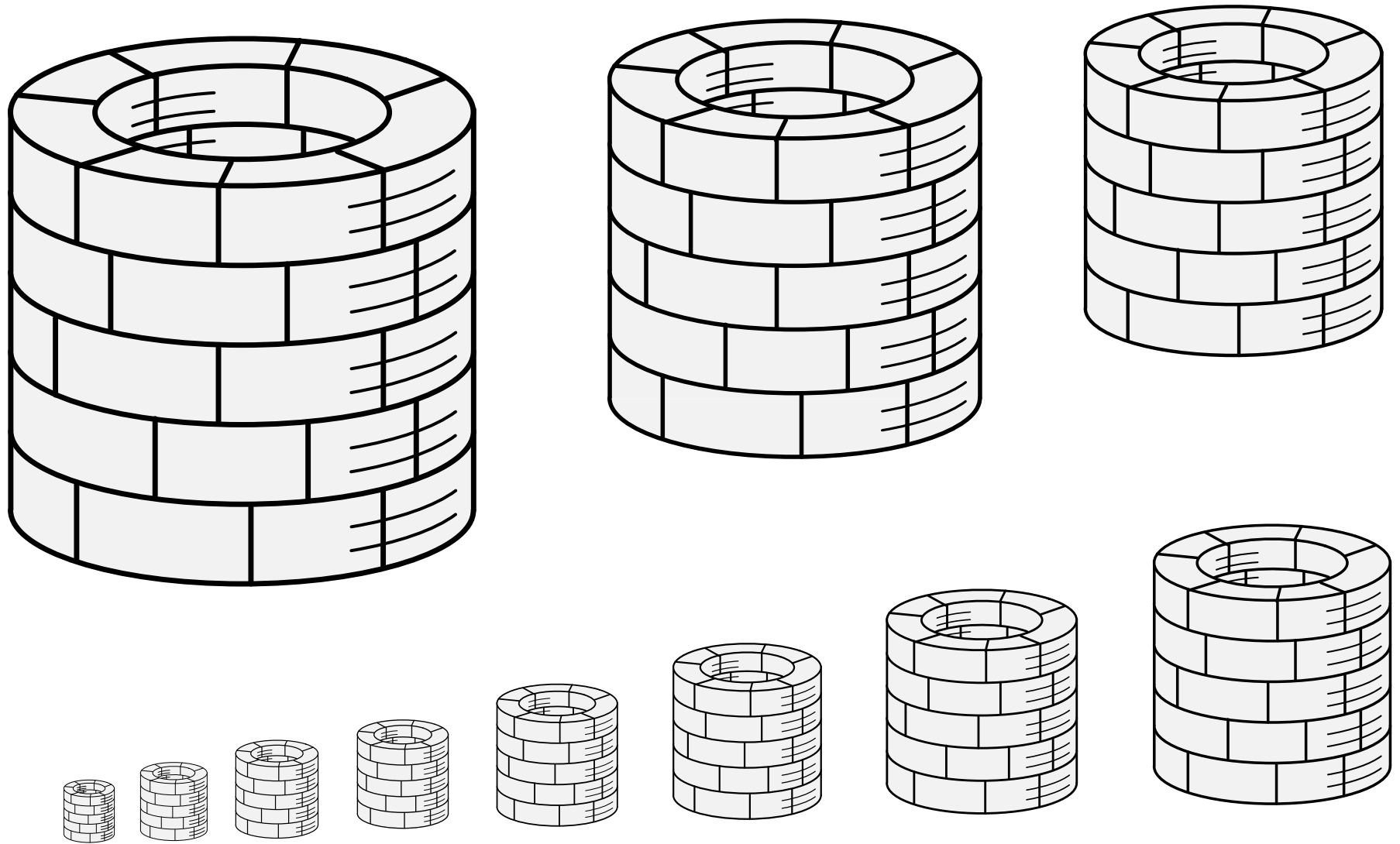

A water source enclosed by a short protective wall.

Default orientation: opening to chief. Proper coloration: gray or argent stone.

Source: The Art of Heraldry. Artist: Unknown.
Adapted by Mathghamhain Ua Ruadháin.

Well, Open (2) 17.248

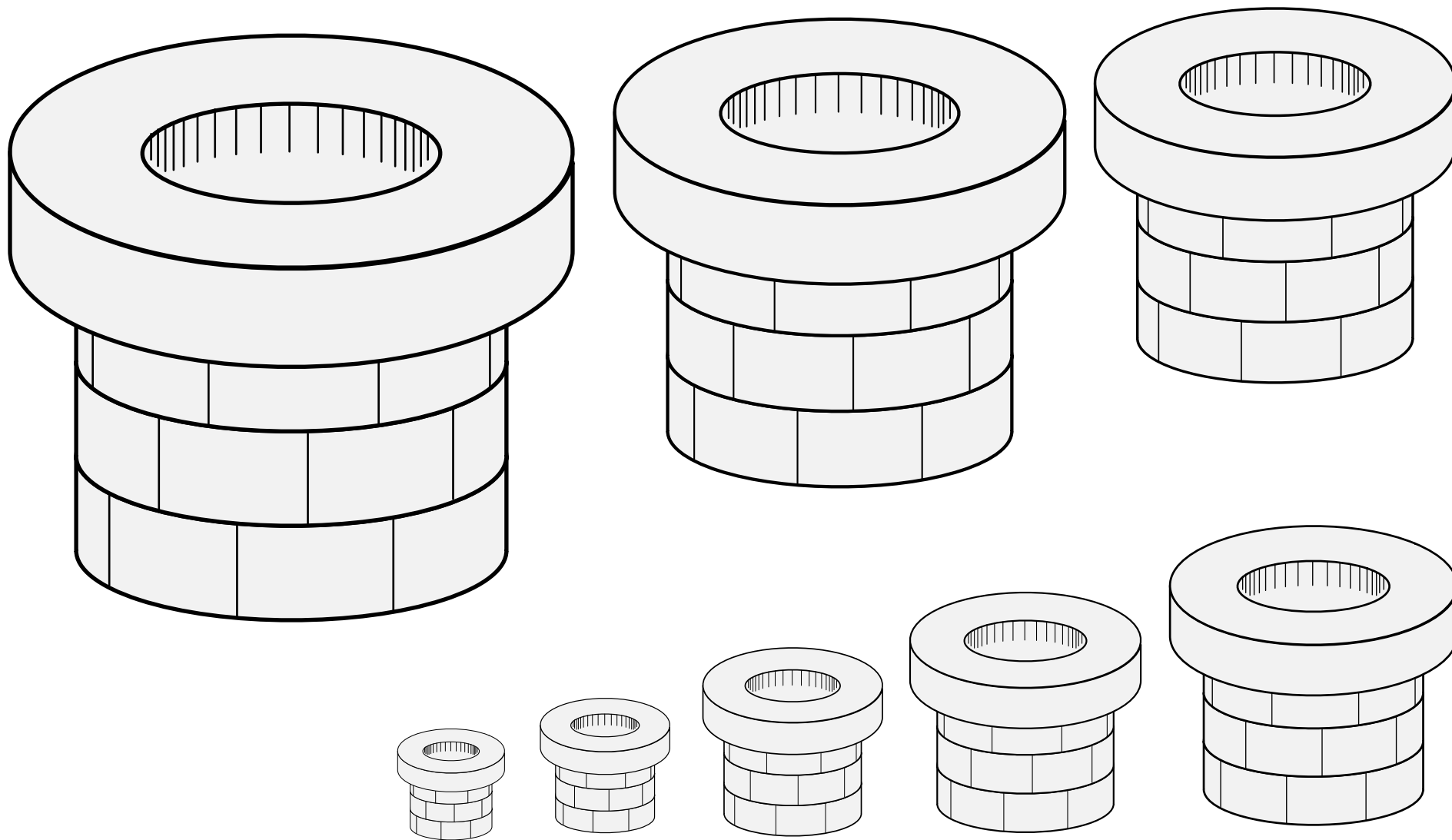

A water source enclosed by a short protective wall.

Default orientation: opening to chief. Proper coloration: gray or argent stone.

Source: Siebmacher's Wappenbuch of 1605. Artist: Johann Siebmacher.
(Arms of Pronner von Tahlhausen, page 98.)

Well, Open (3) 17.249

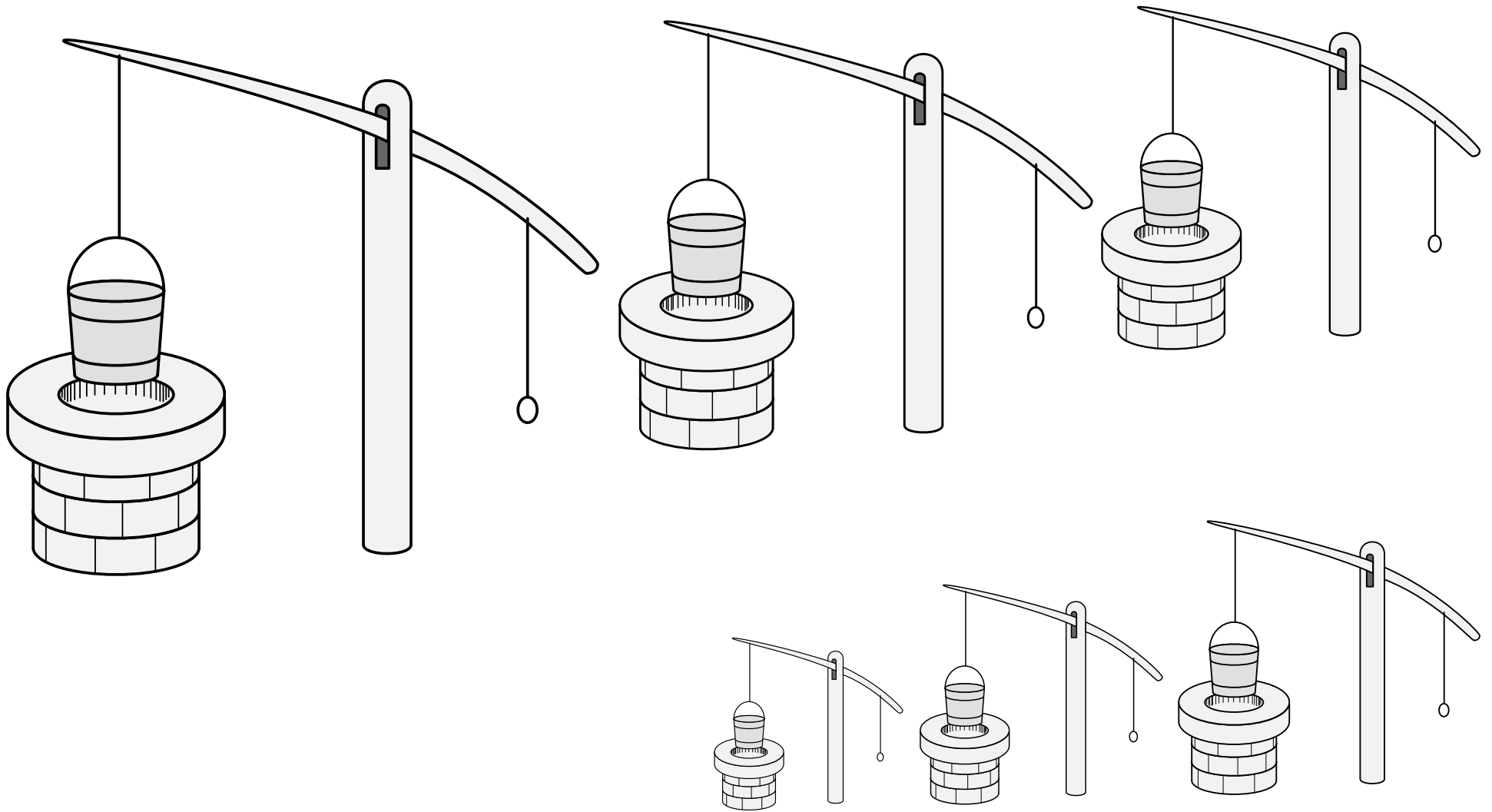

A water source enclosed by a short protective wall.

Default orientation: opening to chief. Proper coloration: gray or argent stone.

The long arm used to raise and lower a water bucket is known as a swape.

Source: Siebmacher's Wappenbuch of 1605. Artist: Johann Siebmacher.
(Arms of Pronner von Tahlhausen, page 98.)

Well, Open (4) 17.250

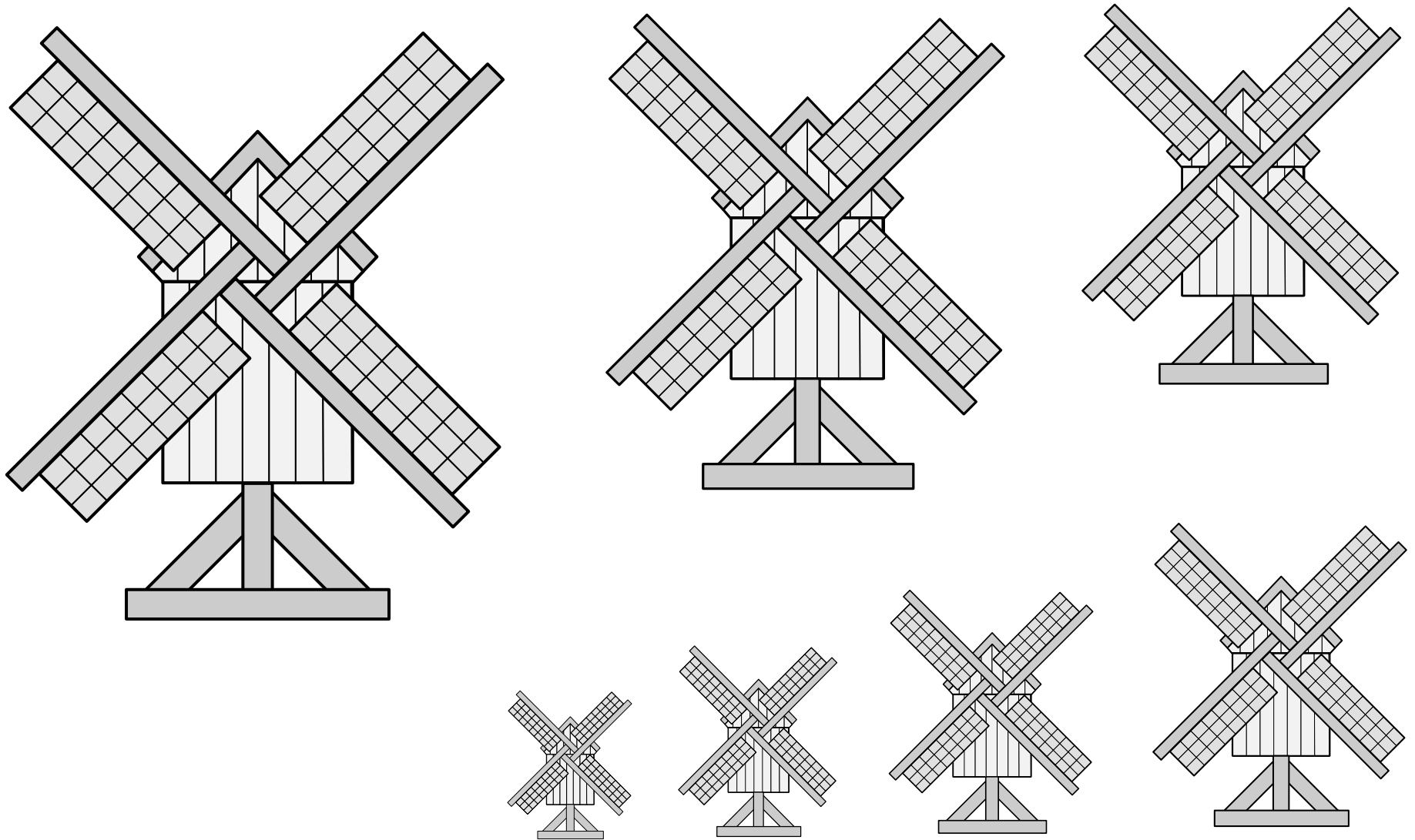

A machine for grinding grain with windpower.

Default orientation: upright, vanes saltirewise. No proper coloration.

Source: Viking Answer Lady SVG Images For Heraldry. Artist: Gunnvôr silfráhr.

Windmill (1) 17.251

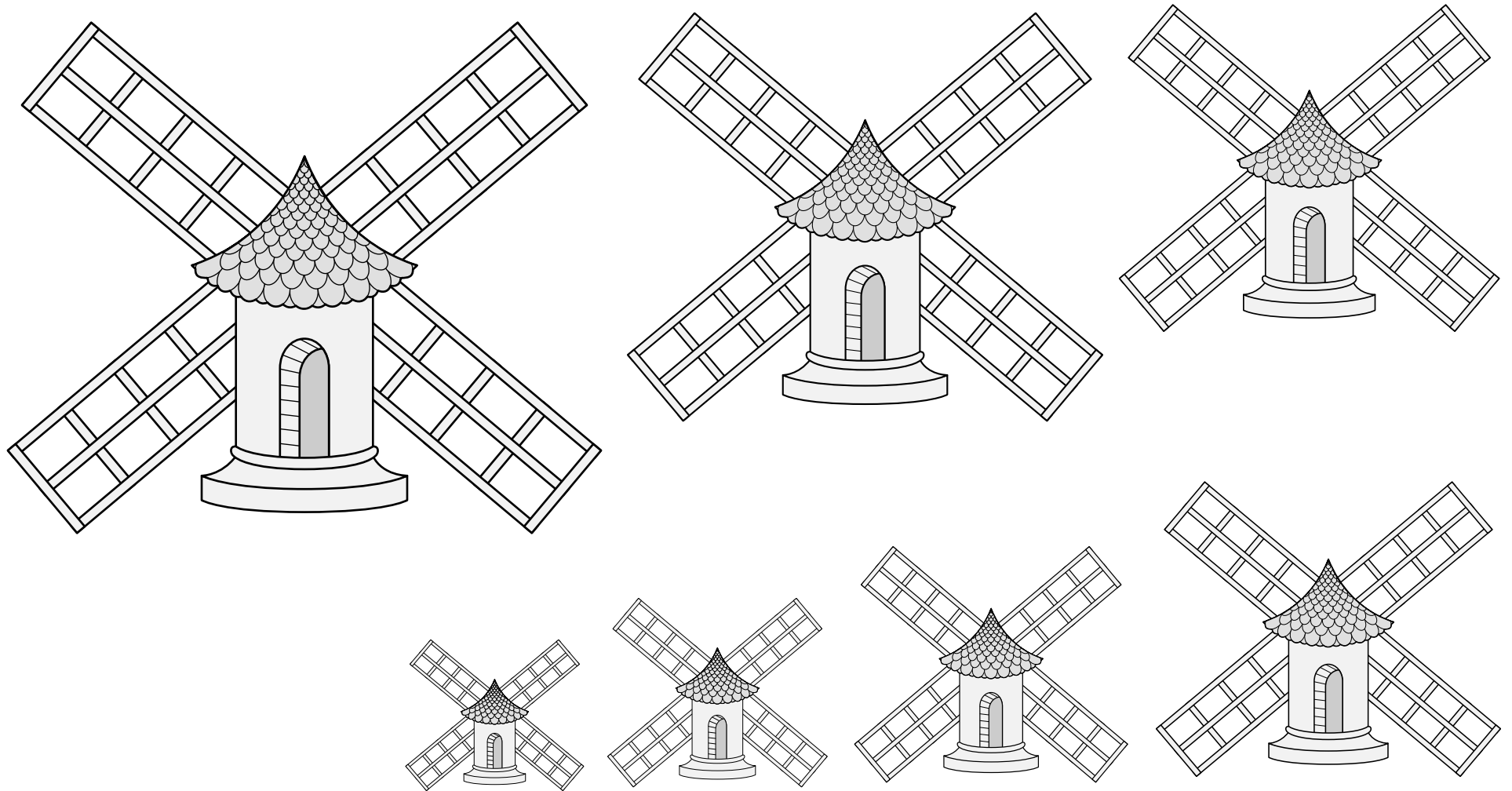

A machine for grinding grain with windpower.

Default orientation: upright, vanes saltirewise. No proper coloration.

Source: Donaueschinger Wappenbuch. Artist unknown. (Folio 12v.)

Windmill (2) 17.252

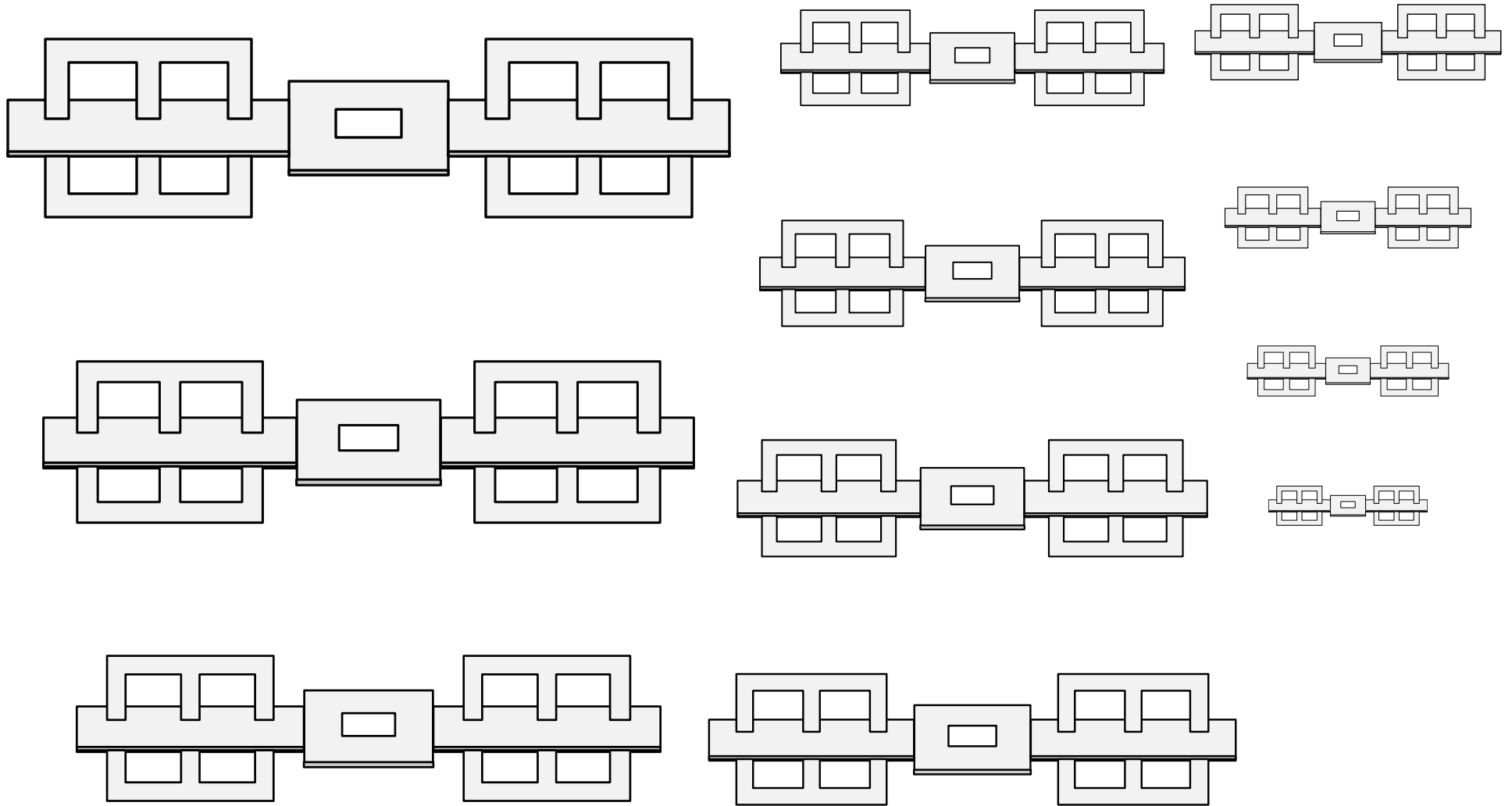

A machine for grinding grain with windpower.

No default orientation. No proper coloration.

Source: Two Tudor Books of Arms. Artist: Robert Cooke.
(From page 26, old arms of Newmarche.)

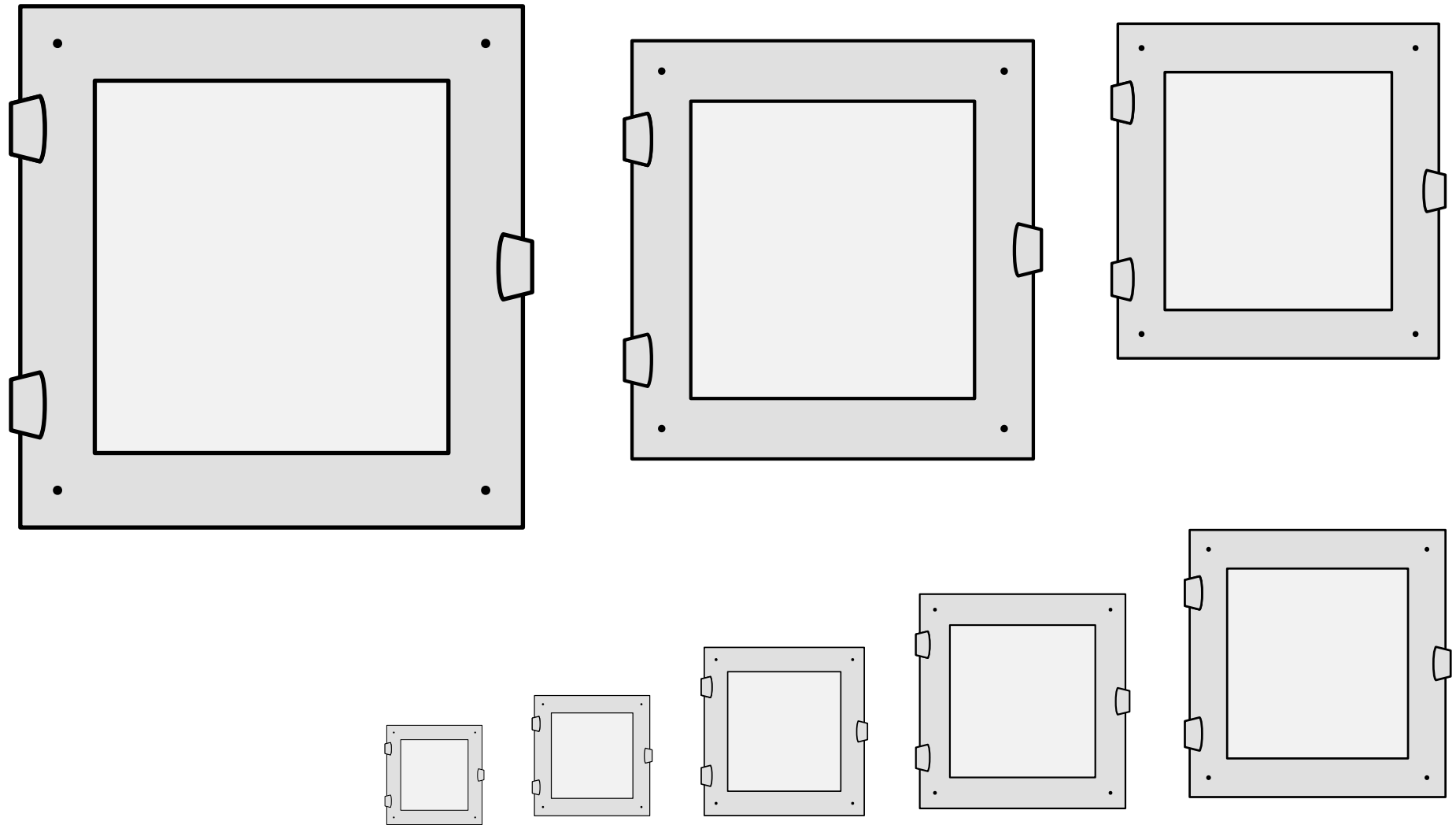

A pane of glass enclosed in a supporting frame that covers a hole in a wall.

No default orientation. No proper coloration.

The central portion may be specifically blazoned as “a window *tincture* glazed *tincture*.”

Source: Siebmacher’s Wappenbuch of 1605.

Artist: Johann Siebmacher. (Arms of Stuben, page 117.)

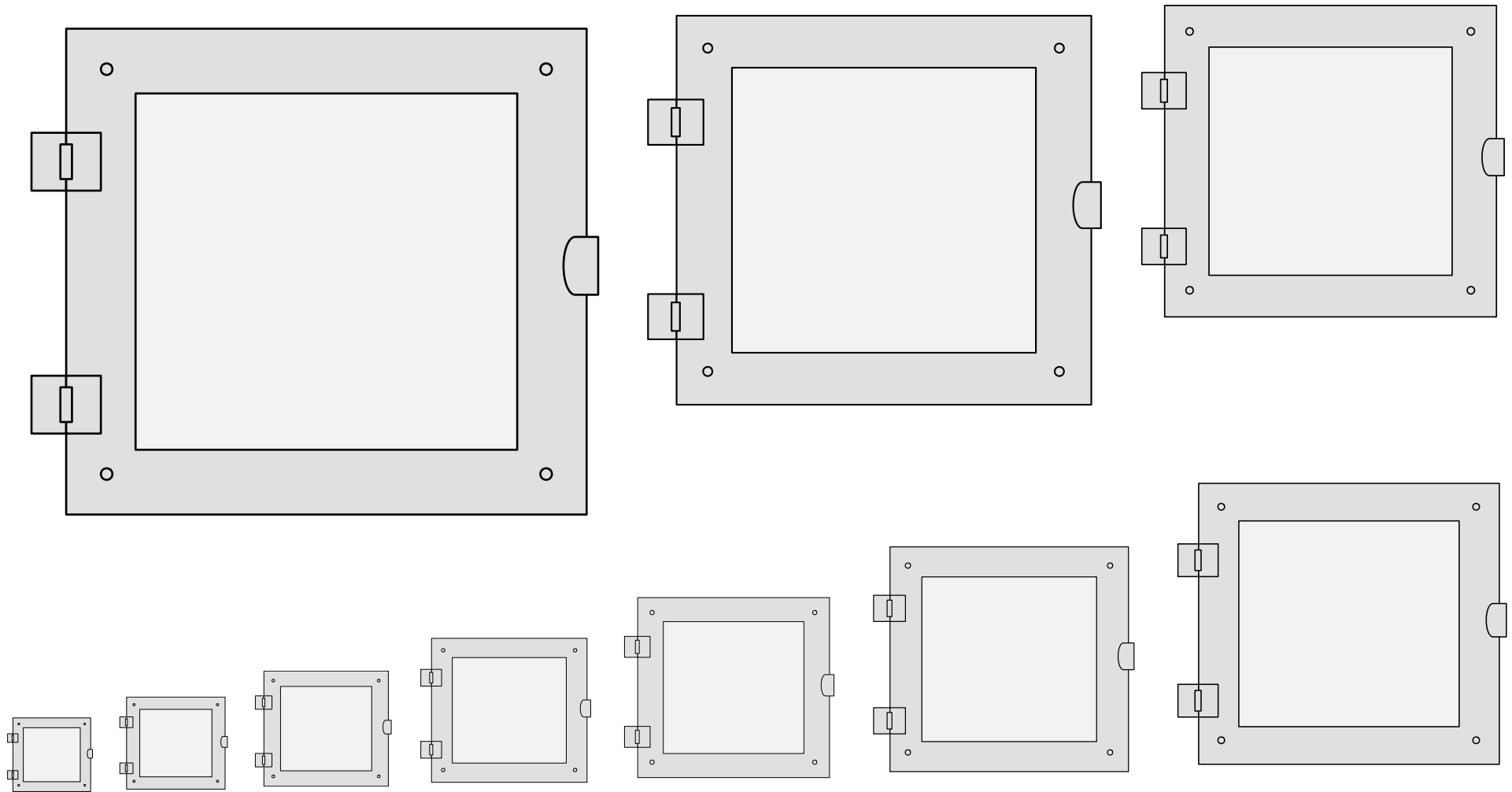

A pane of glass enclosed in a supporting frame that covers a hole in a wall.

No default orientation. No proper coloration.

The central portion may be specifically blazoned as “a window *tincture* glazed *tincture*.”

Source: Siebmacher’s Wappenbuch of 1605.

Artist: Johann Siebmacher. (Arms of Stuben, page 117.)

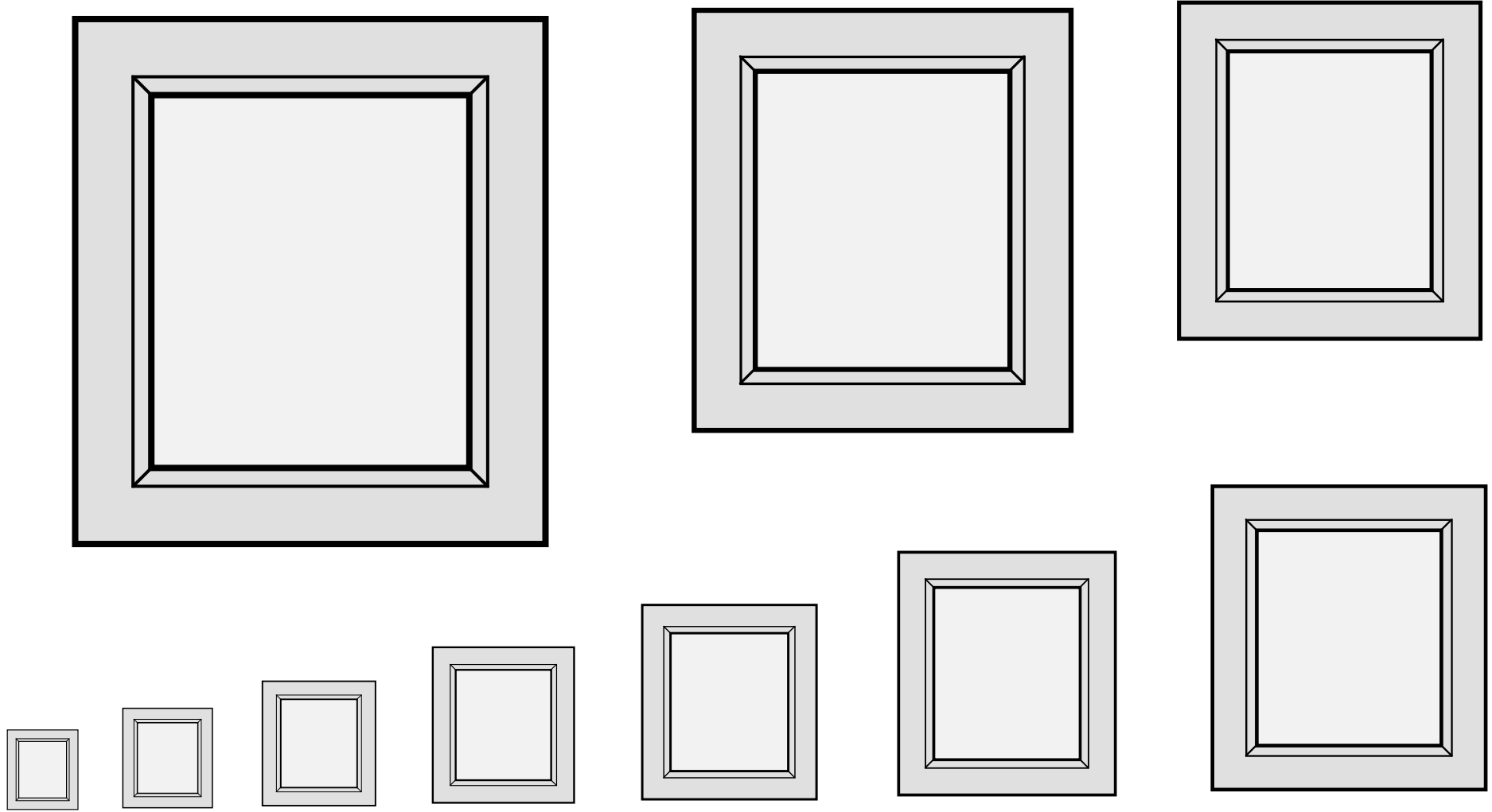

A pane of glass enclosed in a supporting frame that covers a hole in a wall.

No default orientation. No proper coloration.

The central portion may be specifically blazoned as “a window *tincture* glazed *tincture*.”

Source: Scheibler Armorial. Artist: Unknown. (Page 96, arms of Stuben.)

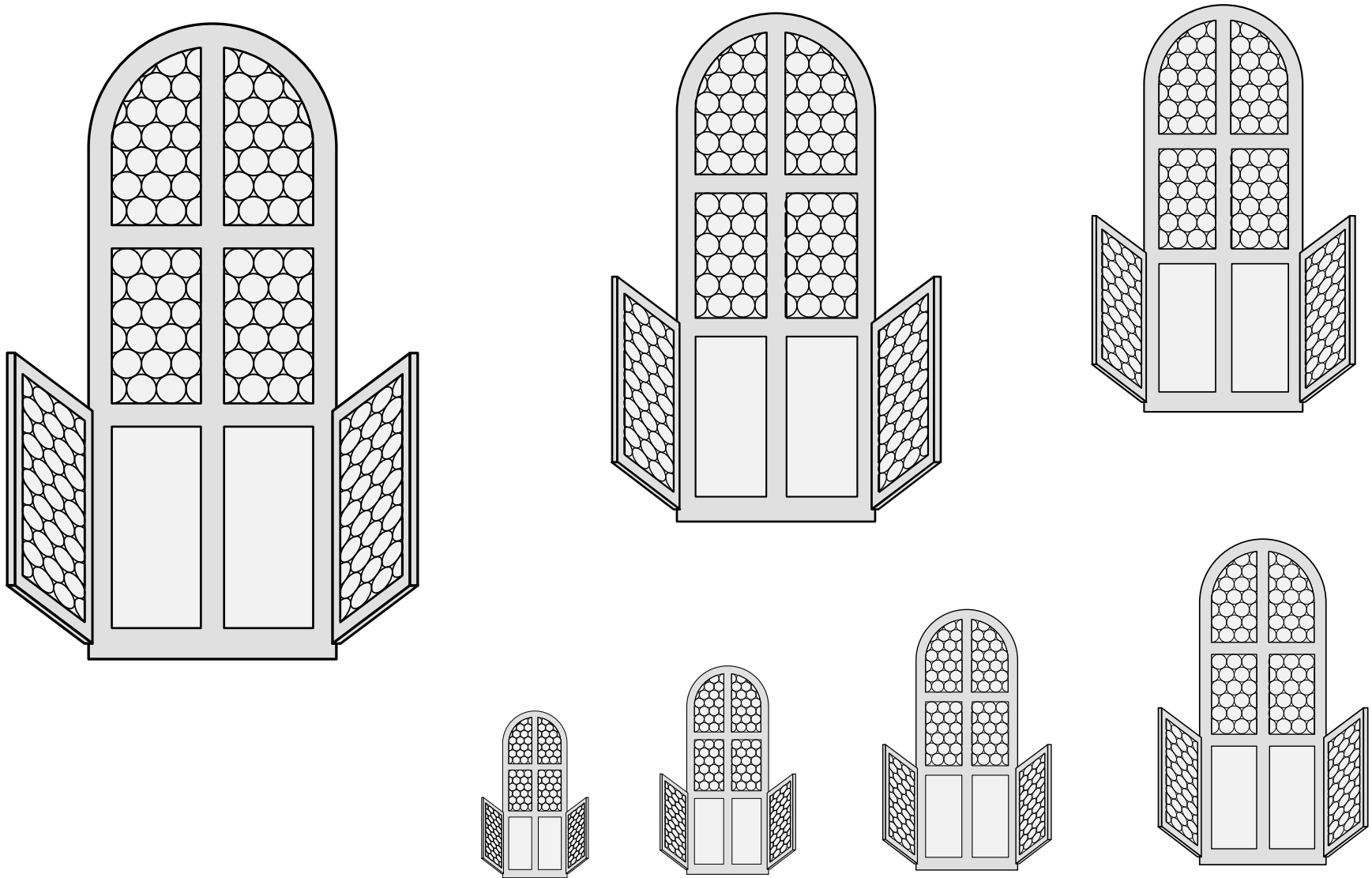

A pane of glass enclosed in a supporting frame that covers a hole in a wall.

No default orientation. No proper coloration. The central portion may be specifically blazoned as “a window *tincture* glazed *tincture*.”

Source: Austrian State Archives. Artist unknown.
(Arms of Fensterer.)

Window, Arched 🍷 17.257

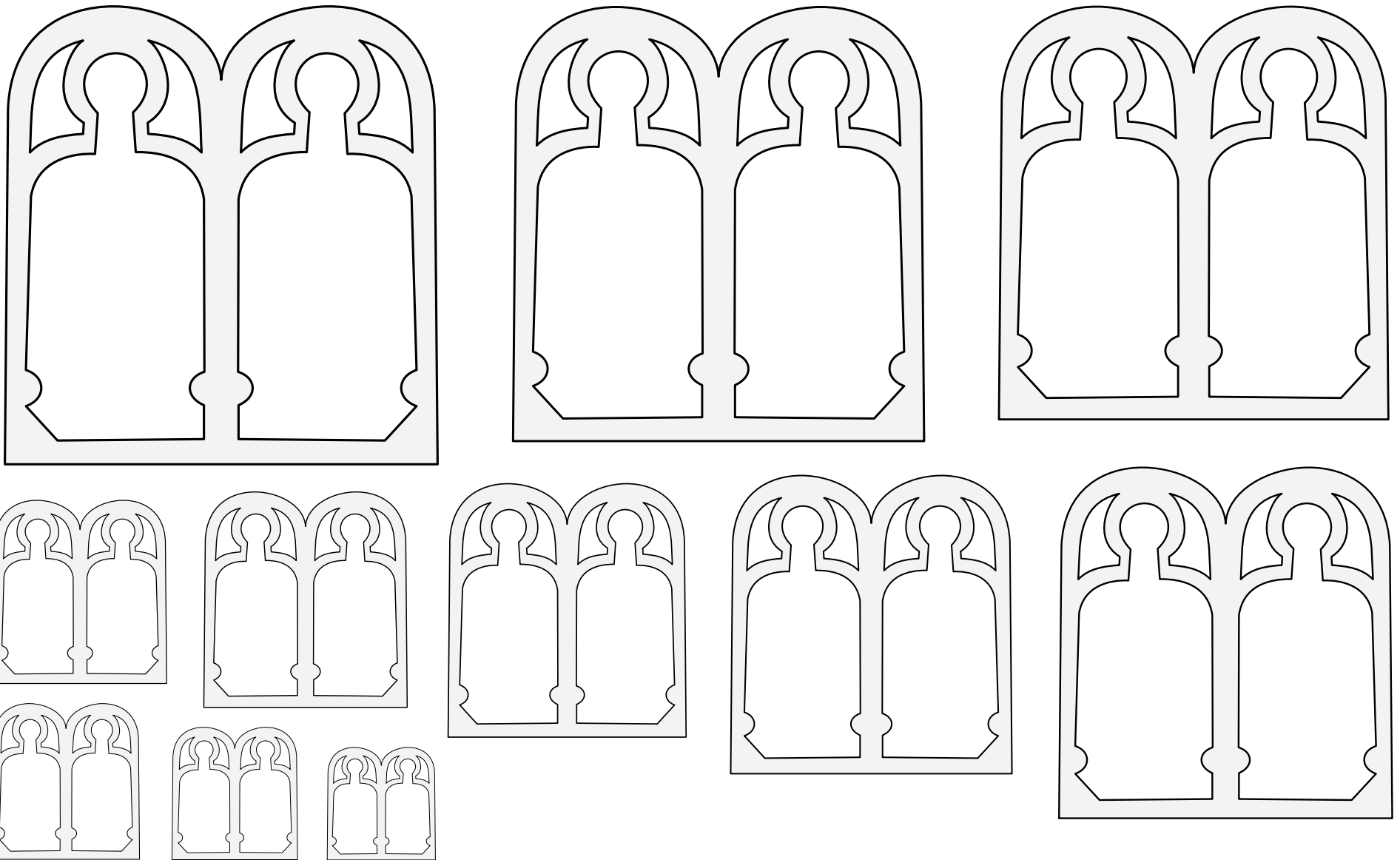

A pane of glass enclosed in a supporting frame that covers a hole in a wall.

No default orientation. No proper coloration. The central portion may be specifically blazoned as “a window *tincture* glazed *tincture*.”

Source: BnF MS Allemand 304. Artist unknown. (Folio 320v.)
Adapted by Iago ab Adam.

Window, Double-Arched 17.258

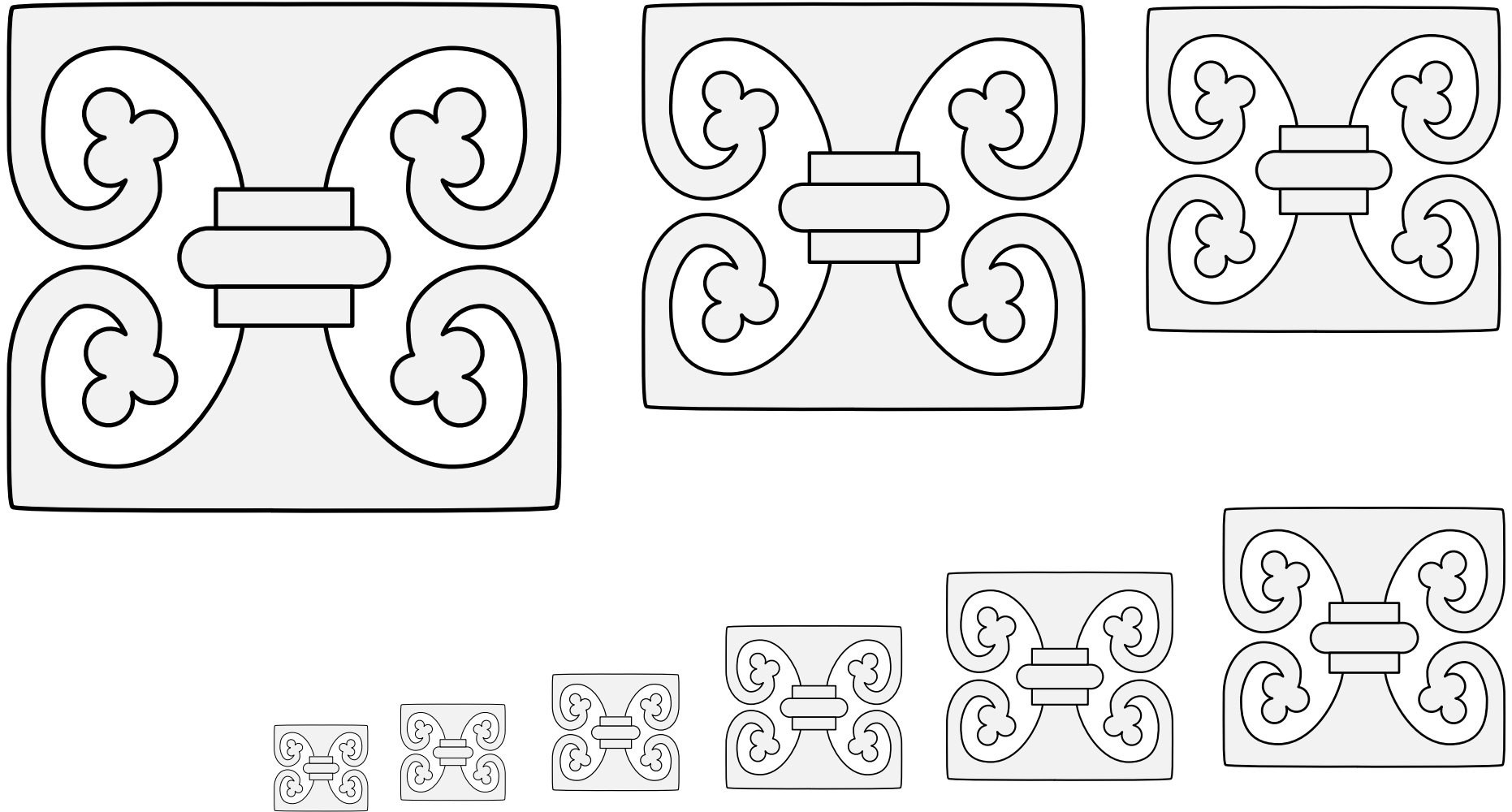

A stylized column — or perhaps it's a table base? Either way, generally understood to be some kind of vertical-support-ish thing.

Default orientation: central portion palewise. No proper tincture.

Source: Beyeren Armorial. Artist: Claes Heinezoon. (Folio 57r, arms of van Zuylen.)

Adapted by Mathghamhain Ua Ruadháin.