

❖ Book of Traceable Heraldic Art ❖

Volume 18:

Arts & Sciences

Including Music, Books, Games,
Sports, Medicine, Magic & Religion

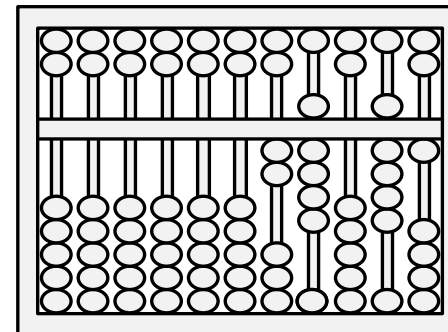
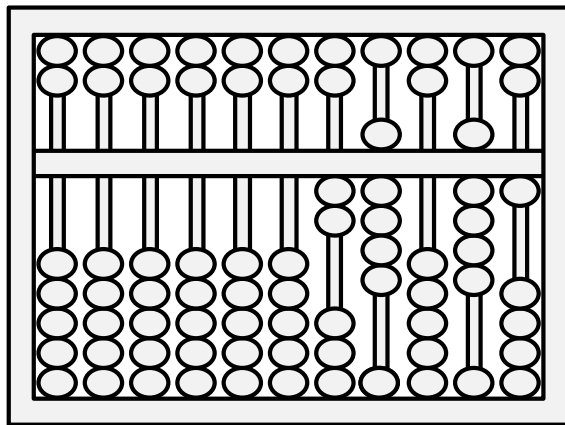
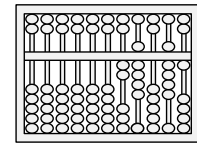
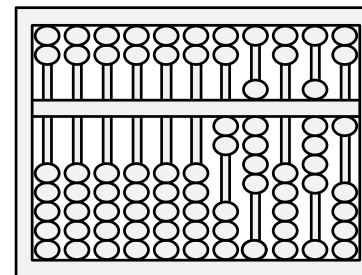
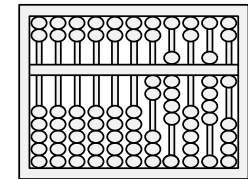
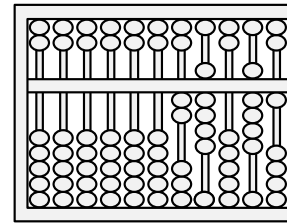
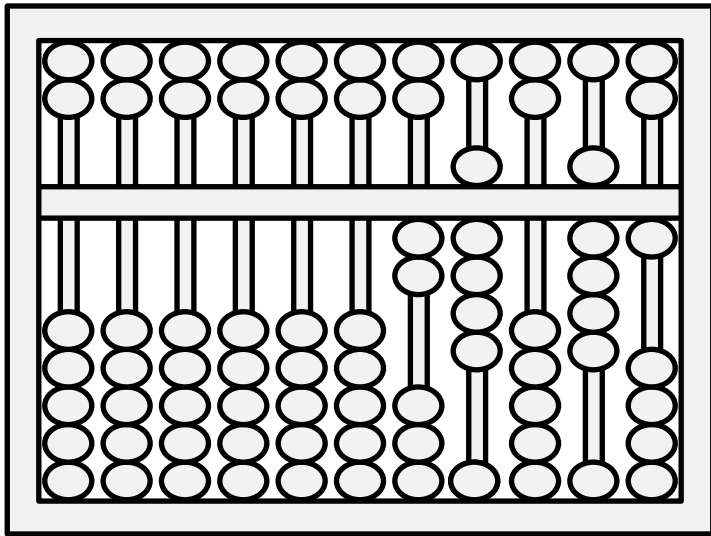

A device for recording counts and performing arithmetic.

Default orientation: fesswise with sliding rails palewise. No proper coloration.

A period artifact, not used in period armory. The version depicted here originated in Asia, and is considered a Step From Period Practice (SFPP) as it was not used in medieval Europe. Prior to the November 2020 LoAR it was often referred to a "oriental abacus."

Source: Viking Answer Lady SVG Images For Heraldry.

Artist: Gunnvôr silfrhárr.

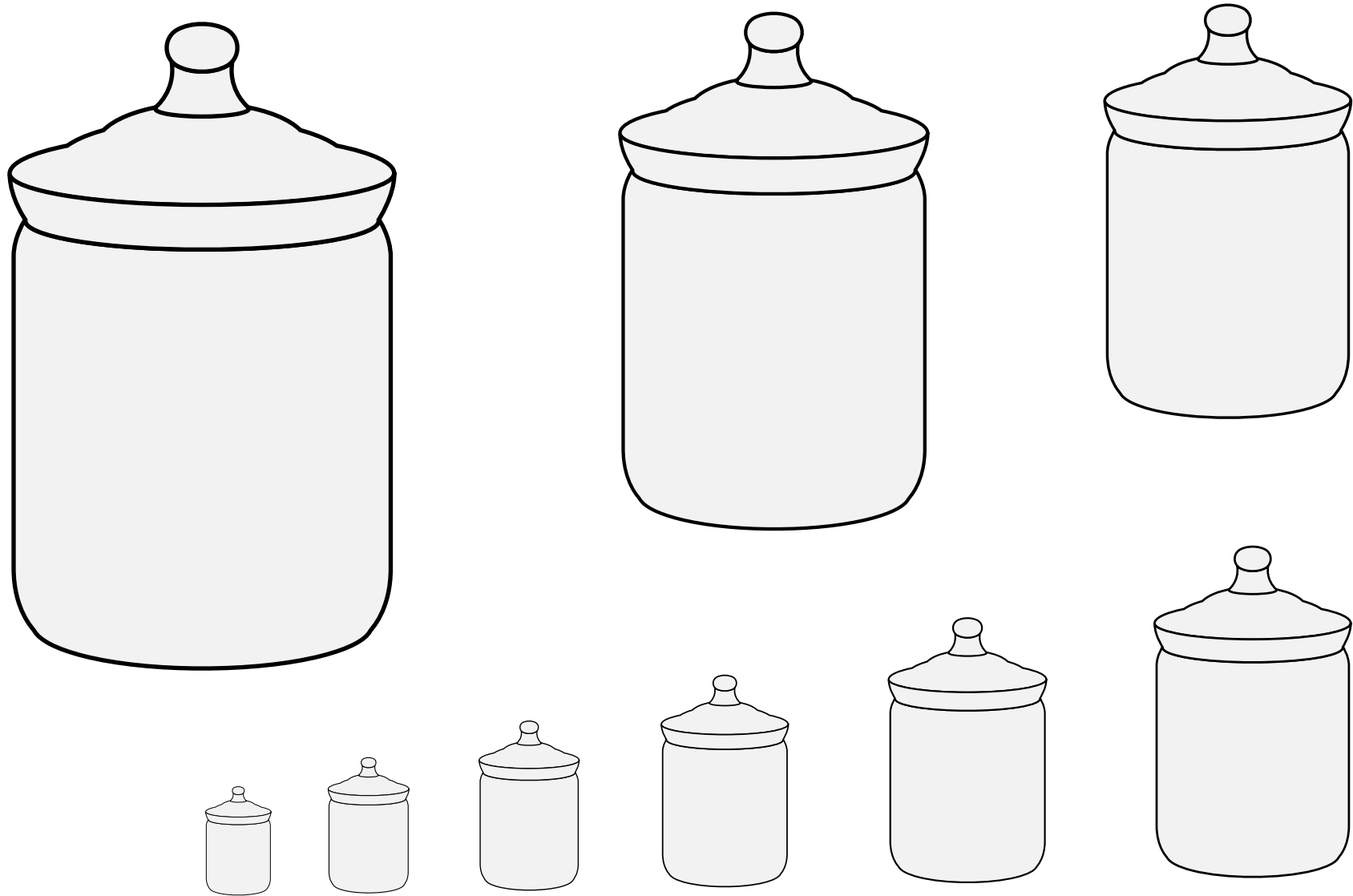

A glass jar used to store medical supplies.
Default orientation: cover to chief. No proper coloration.

Apothecary Jar 18.3

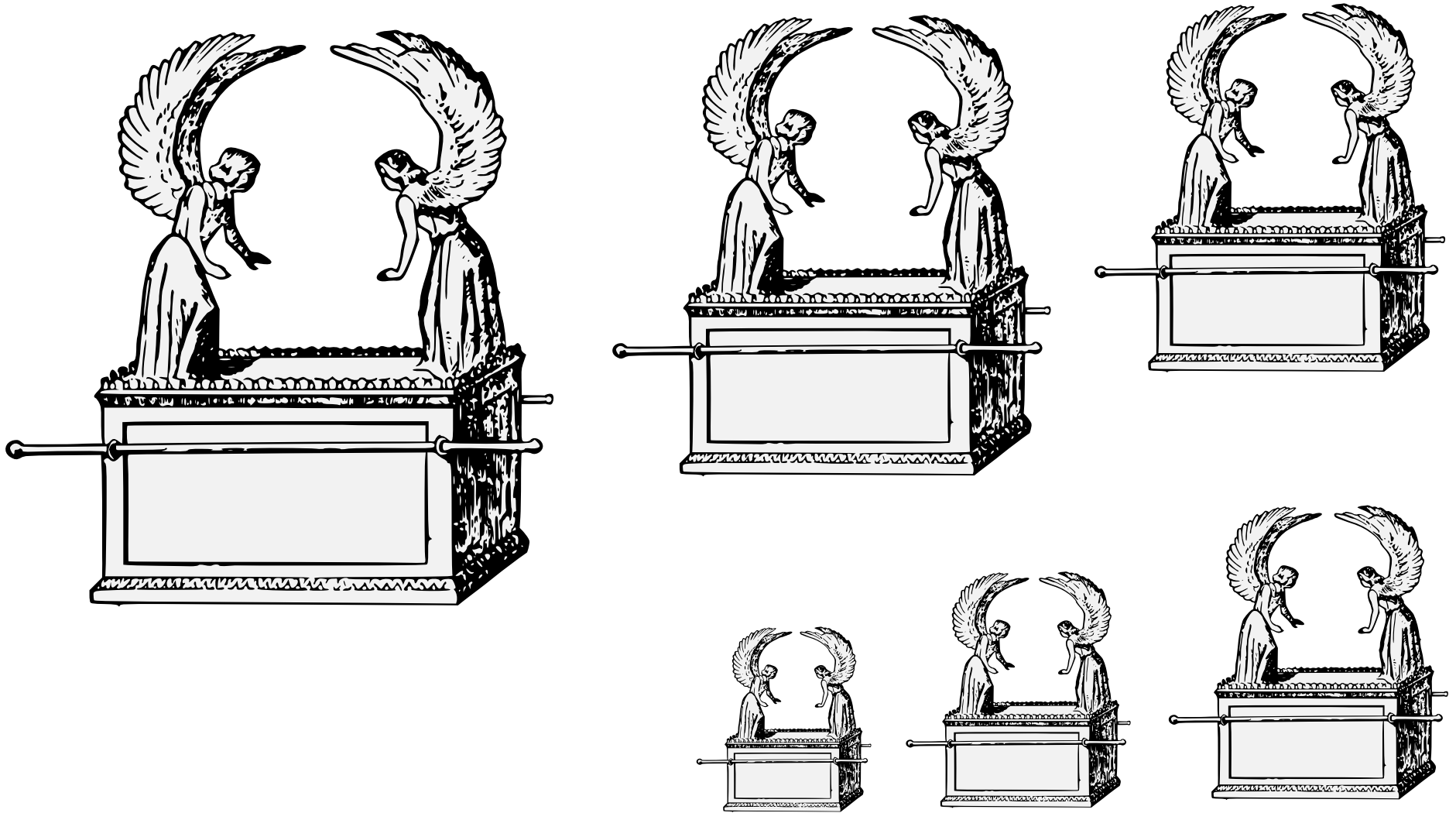

A specialized chest for carrying holy relics.

Default orientation: upright. No proper coloration.

Source: Outlines of Greek History. (William C. Morey, 1903.)

Artist unknown.

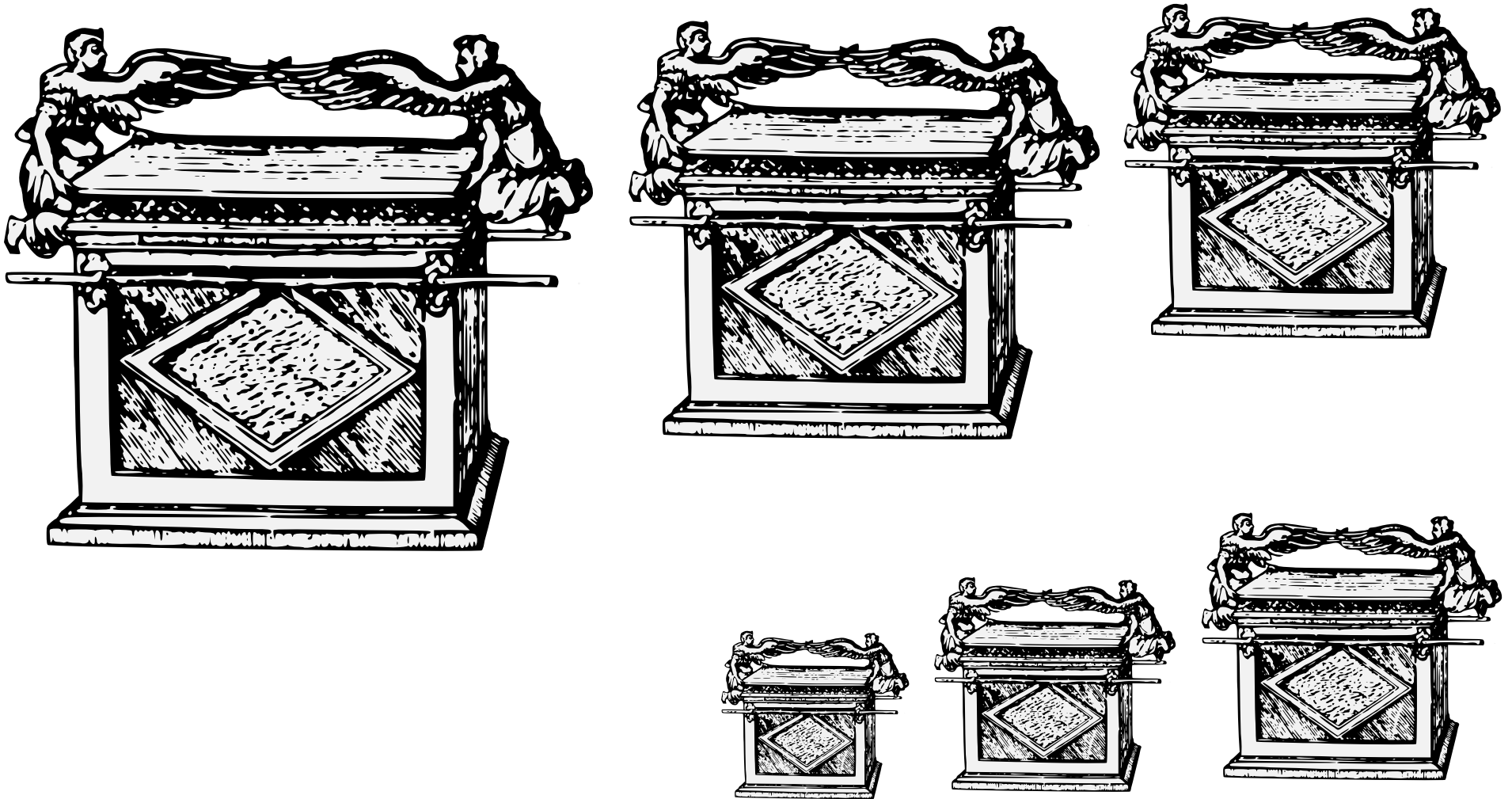

A specialized chest for carrying holy relics.

Default orientation: upright. No proper coloration.

Source: The Bible. (German text, printed in Nuremberg in 1670.) Artist: LG.

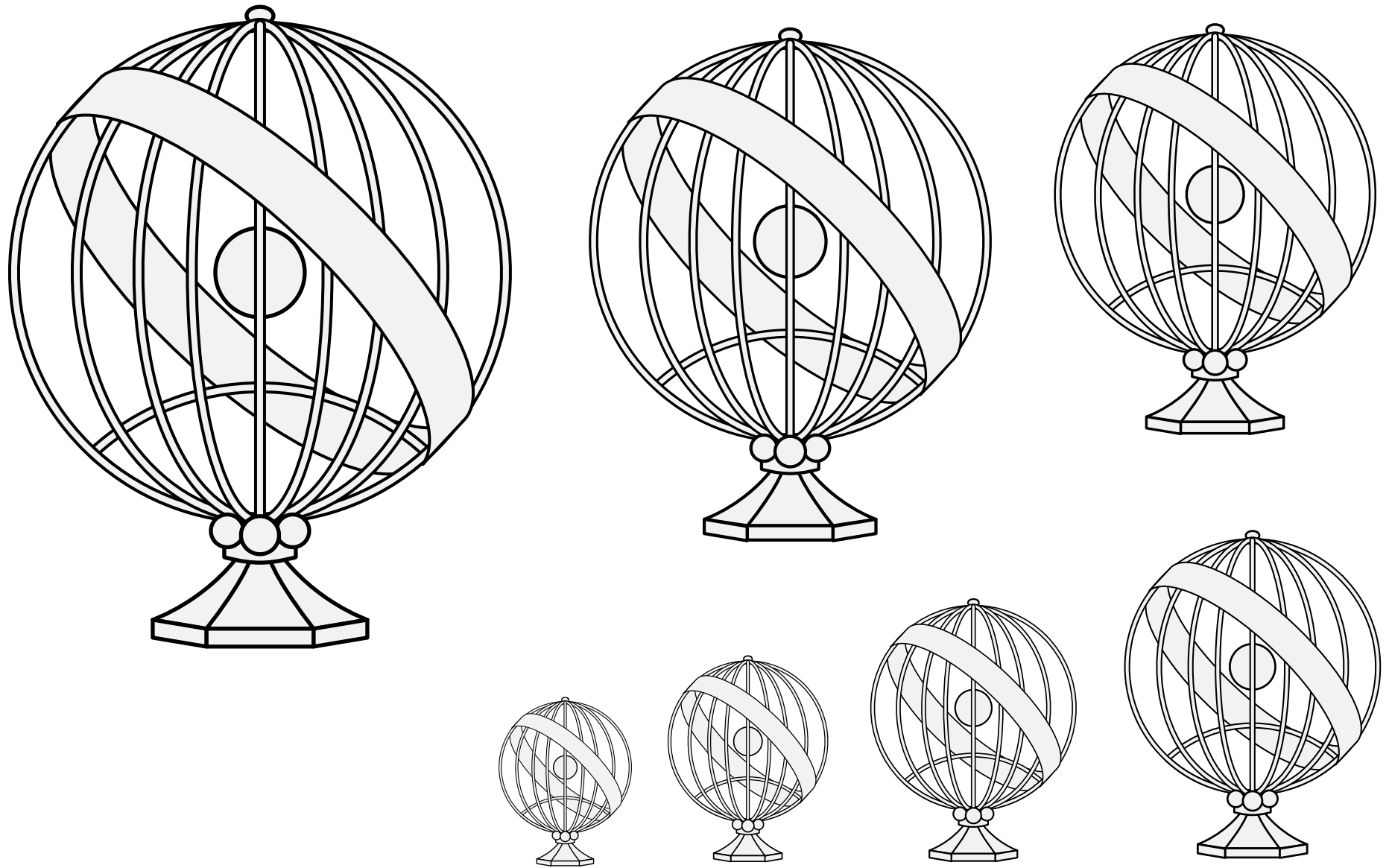

An astronomical model of the heavens surrounding the earth

Default orientation: stand to base. No proper coloration.

Source: A Glossary of Terms Used in Heraldry. Artist: James or Irene Parker.
Adapted by Mathghamhain Ua Ruadháin.

Armillary Sphere 18.6

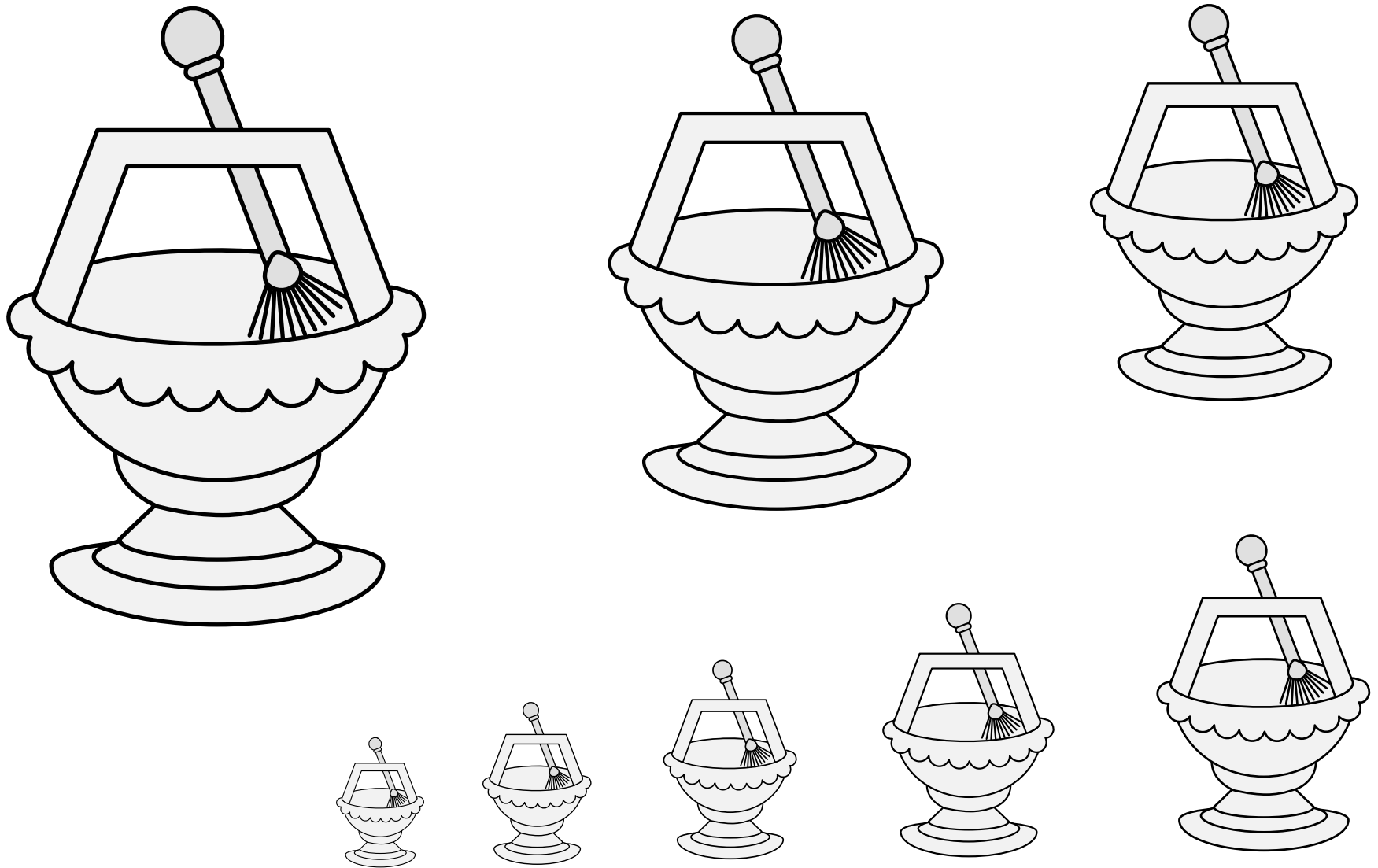

A container and tool for sprinkling holy water.

Default orientation: upright. No proper coloration.

Source: Sarum Processional. Artist unknown.
Adapted by Mathghamhain Ua Ruadháin.

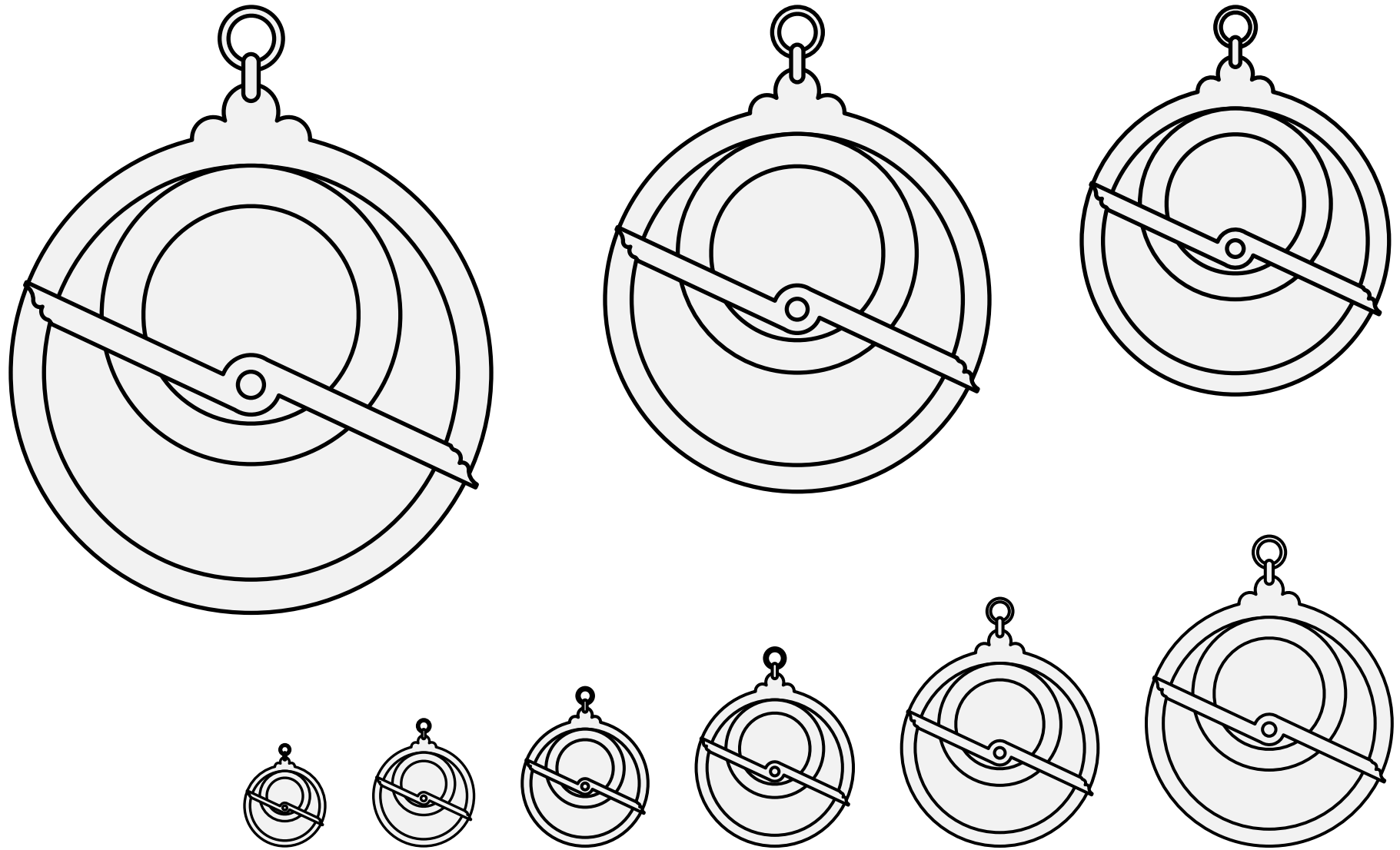

A tool for measuring the position of celestial bodies.

Center section is solid, not colored of the field.

Source: Viking Answer Lady SVG Images For Heraldists. Artist: Gunnvôr silfráhr.

Astrolabe (1) 18.8

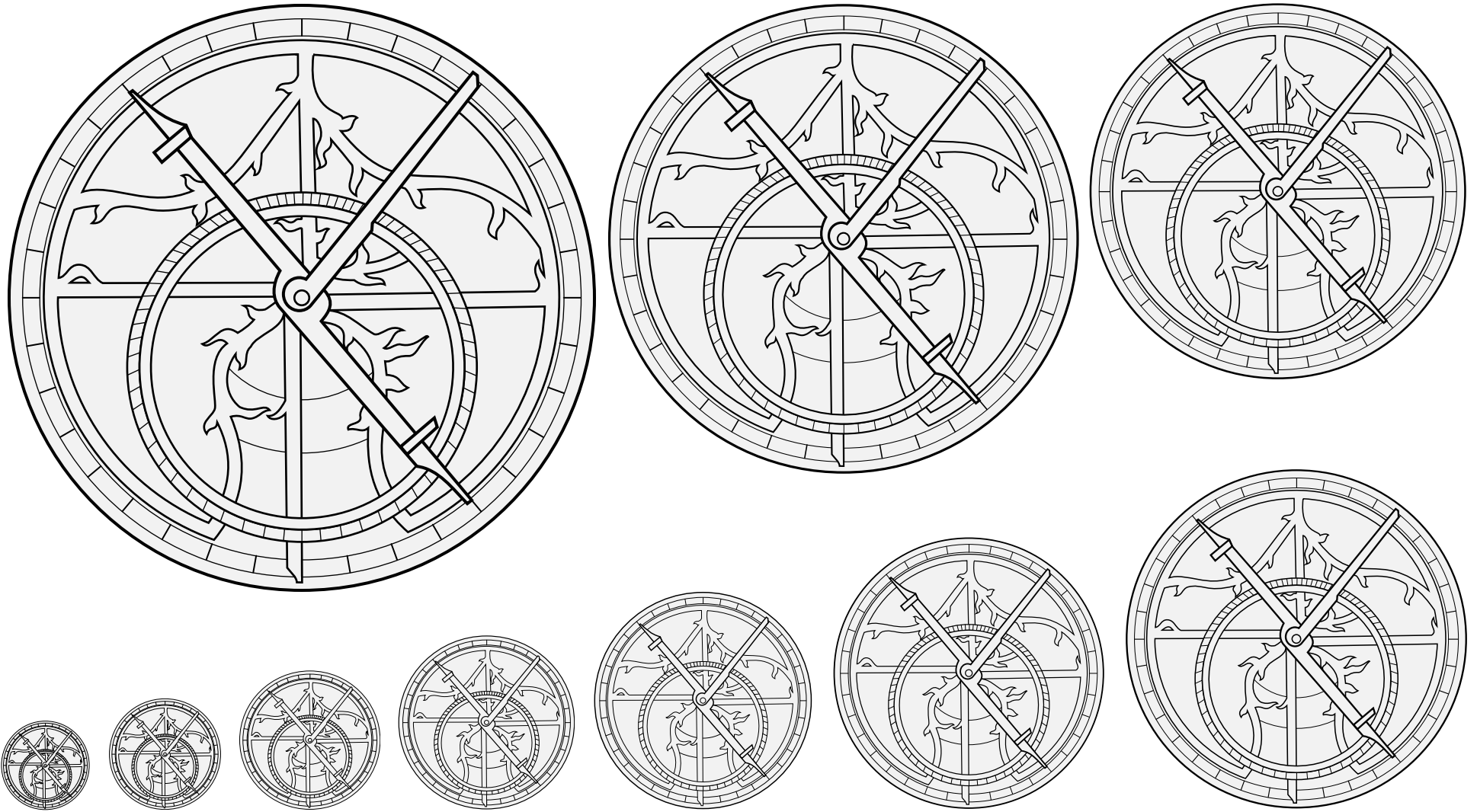

A tool for measuring the position of celestial bodies.

Center section is solid, not colored of the field.

Source: SVG Heraldry Components. Artist: Nicholas de Estleche.

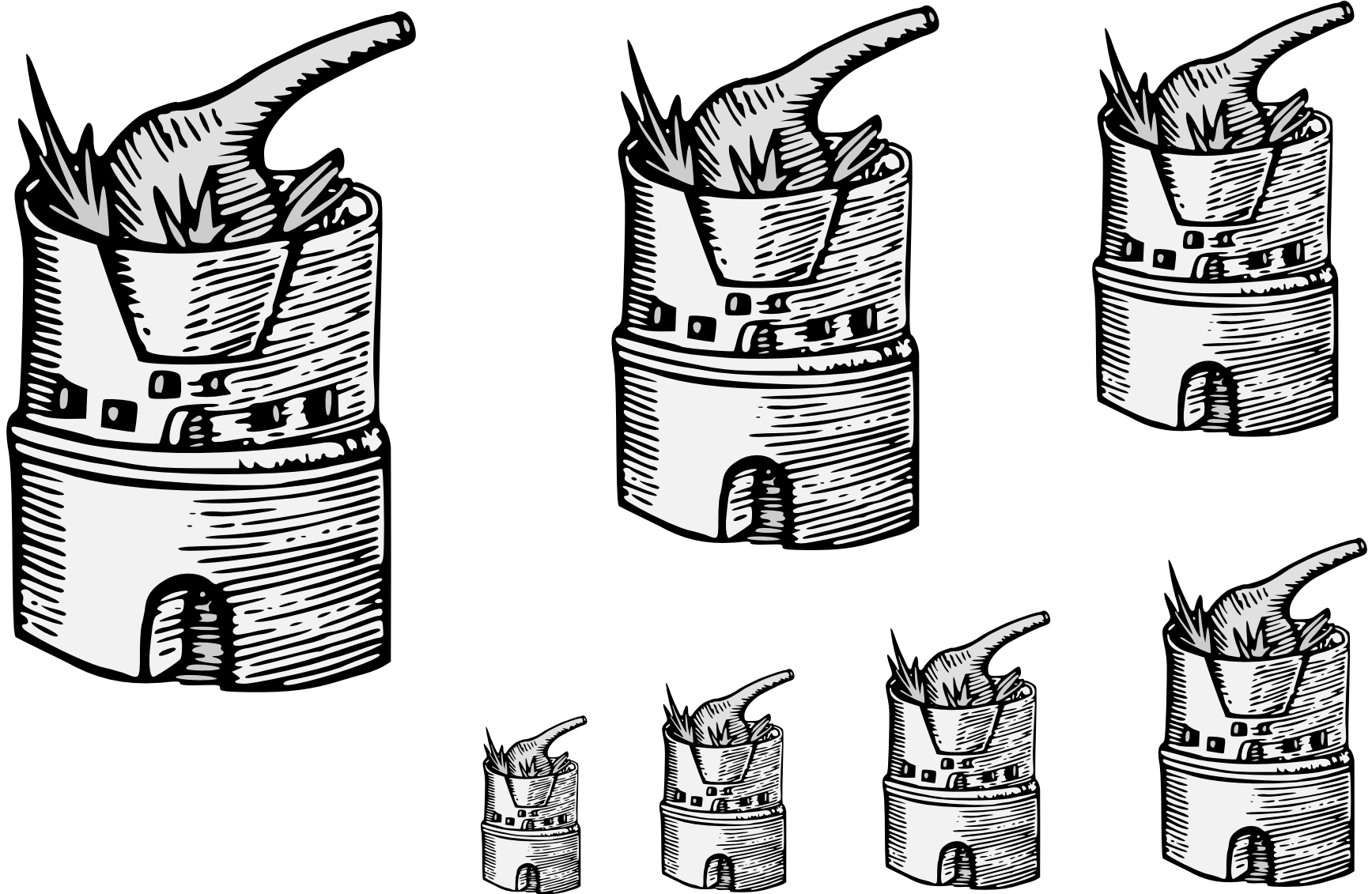

A furnace designed to heat alchemical materials.
Default orientation: upright. No proper coloration.
Source: Coelum Philosophorum. (Philipp Ulstad's 1544 edition.) Artist unknown.

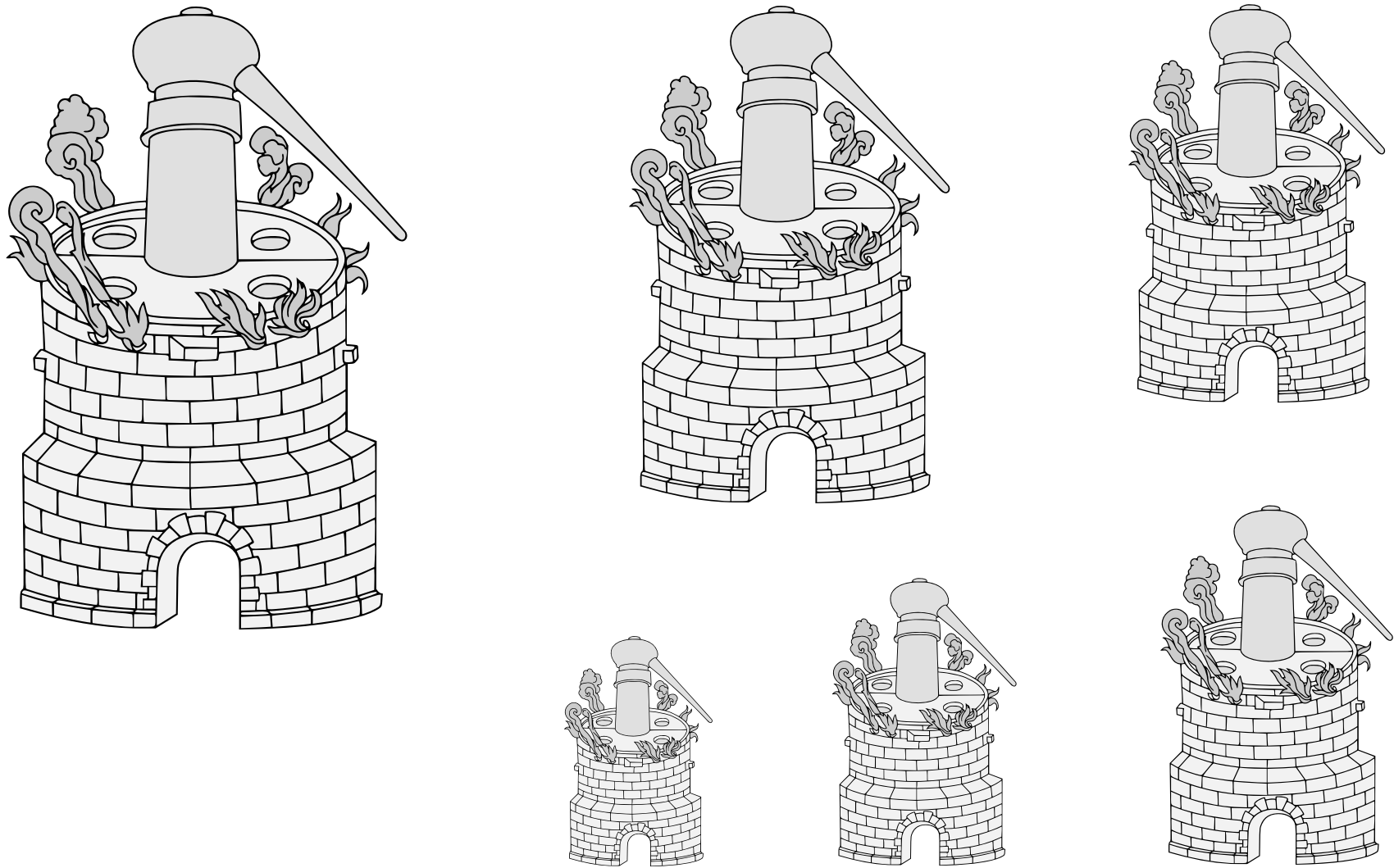

A furnace designed to heat alchemical materials.
Default orientation: upright. No proper coloration.
Source: Sledgehammer. Artist: Grimwulf Harland.

Athanor With a Retort Atop (2) 18.11

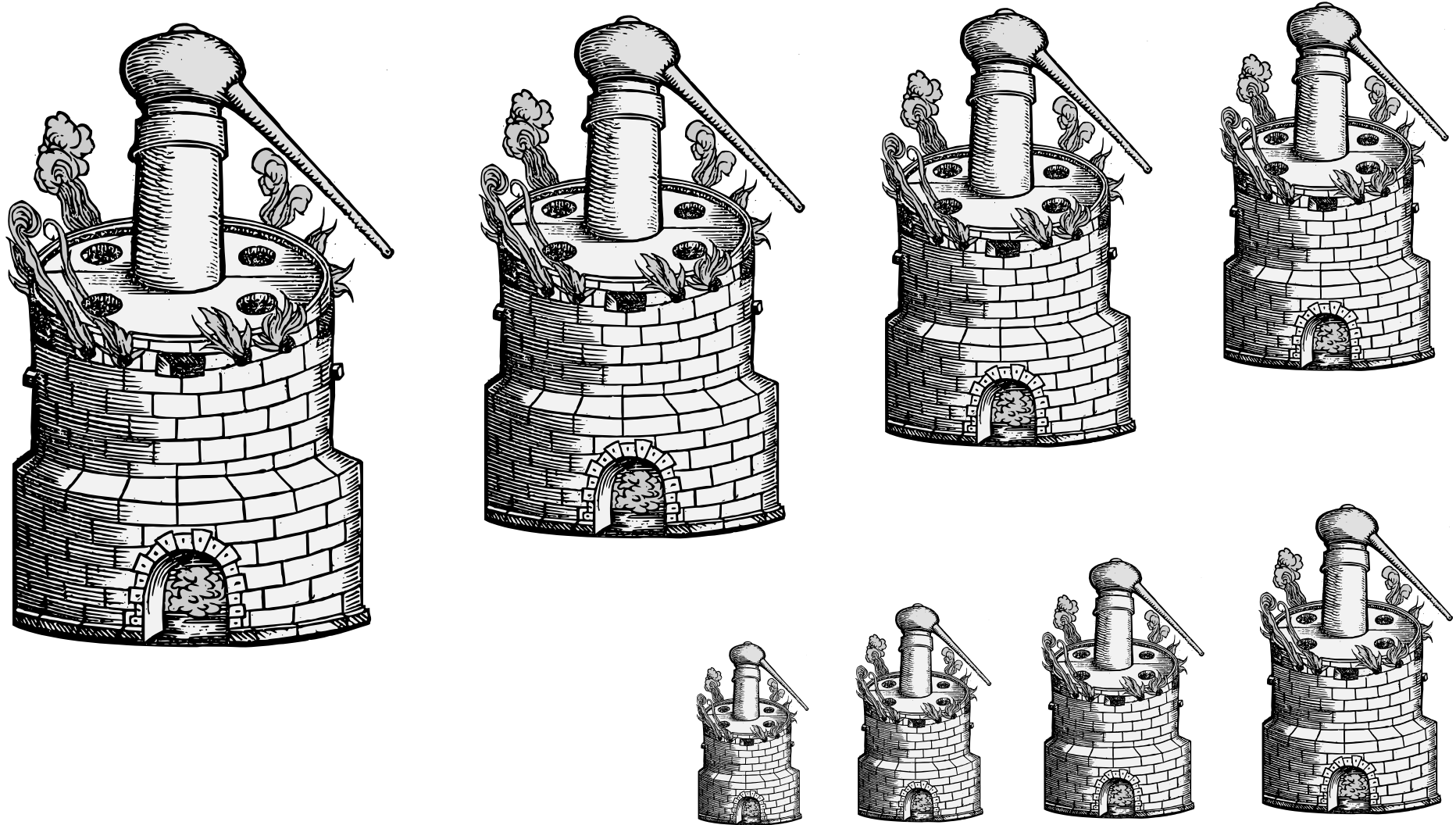

A furnace designed to heat alchemical materials.
Default orientation: upright. No proper coloration.
Source: Alchemiae Gebri Arabis Libri.
(Berne, 1545.) Artist unknown.

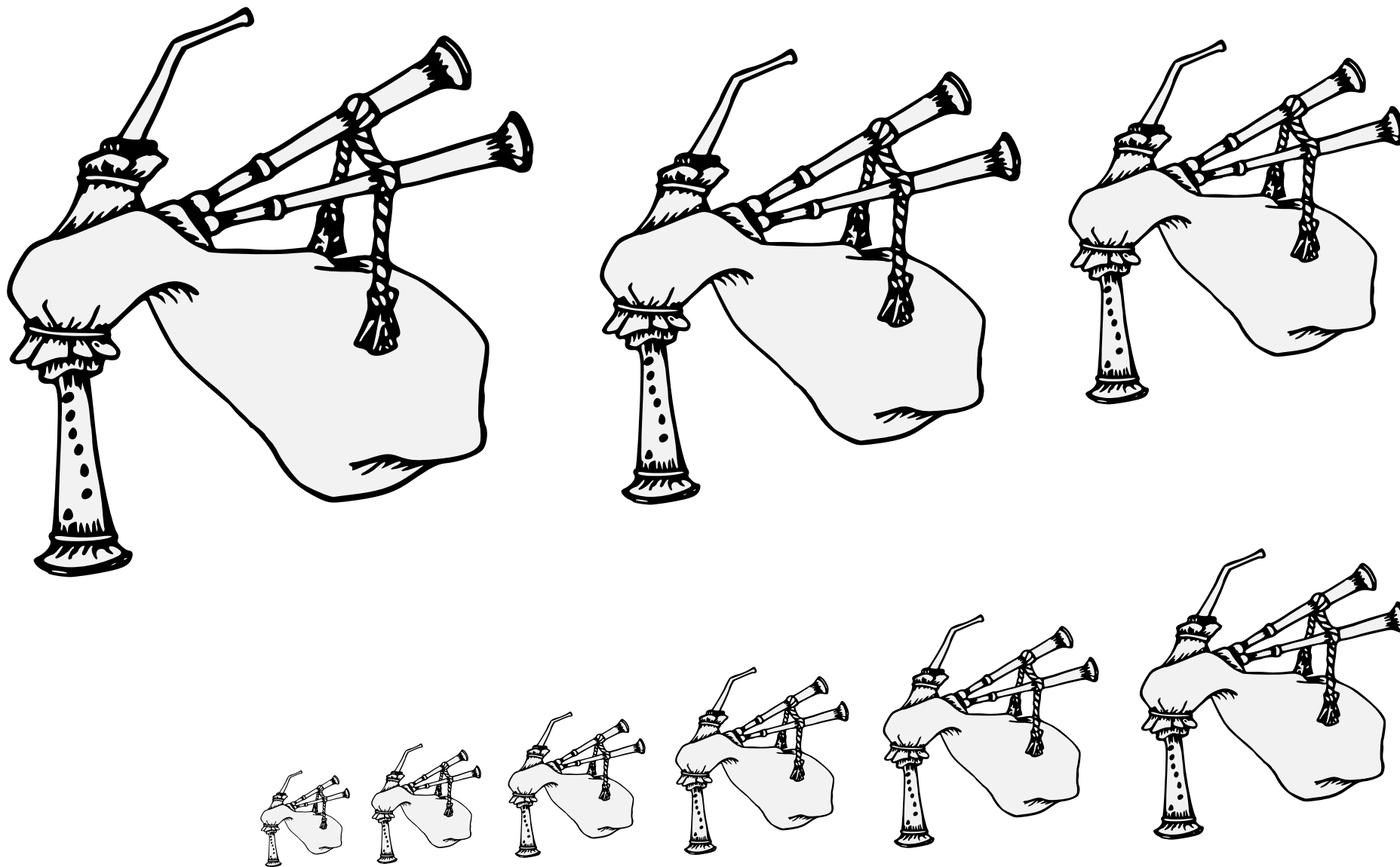

A wind instrument.

Default orientation: chanter to dexter base.

Source: Heraldic Templates. Artist: Torric inn Björn.

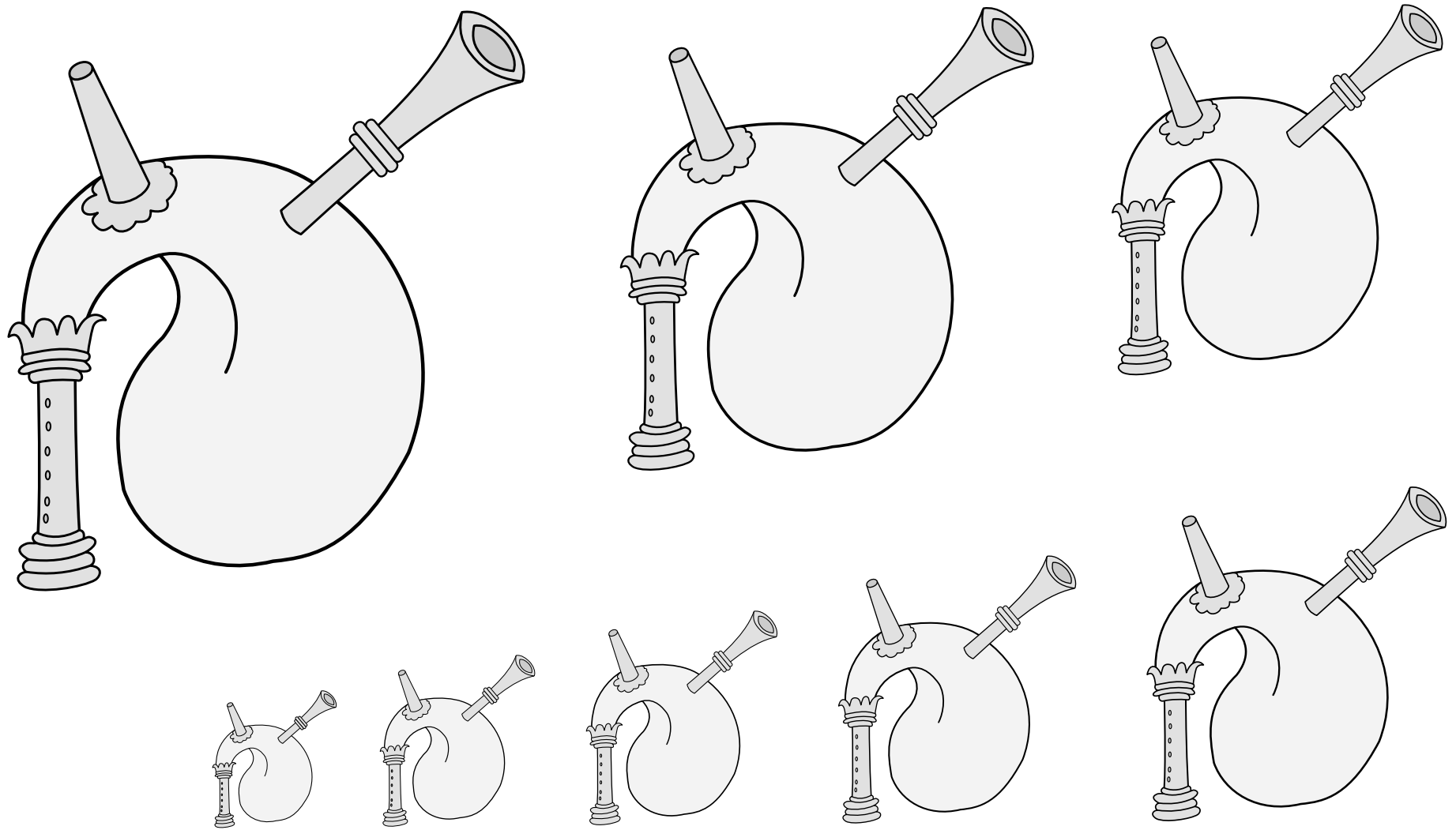

A wind instrument.

Default orientation: chanter to dexter base.

Source: A Display of Heraldry. Artist: John Guillim.
(Manuscript folio 93v.) Adapted by Iago ab Adam.



A metal instrument that makes a sound when shaken or hit.

Default orientation: palewise. No proper coloration.

This variety may also be blazoned a “church bell.”

Source: A Complete Guide to Heraldry. Artist: Graham Johnston.

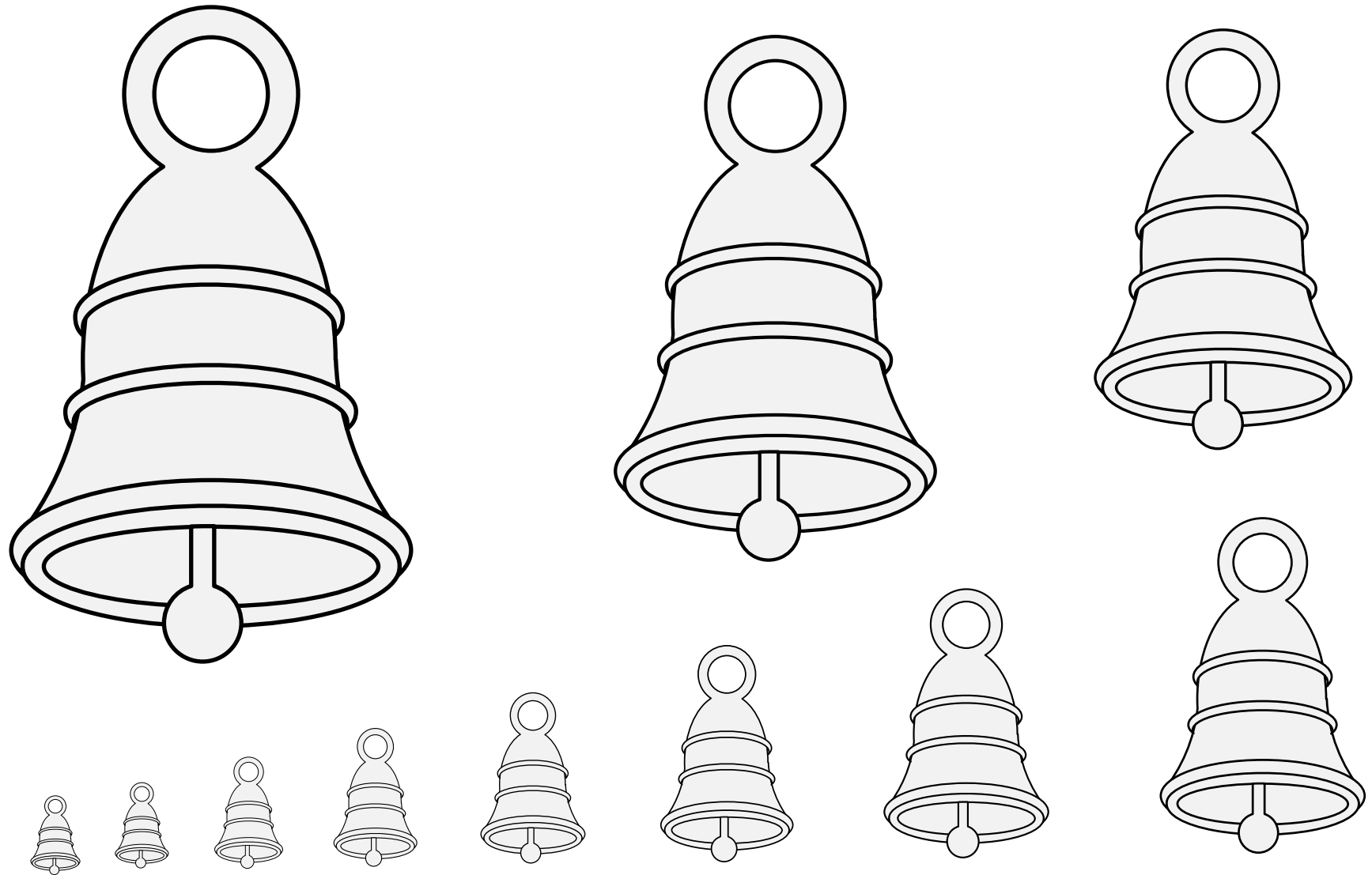

A metal instrument that makes a sound when shaken or hit.

Default orientation: palewise. No proper coloration.

This variety may also be blazoned a “church bell.”

Source: Viking Answer Lady SVG Images For Heraldists. Artist: Gunnvôr silfráhr.

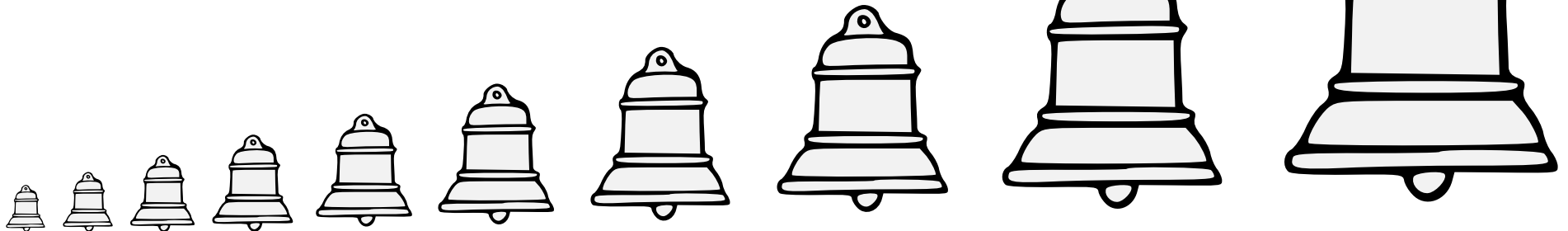
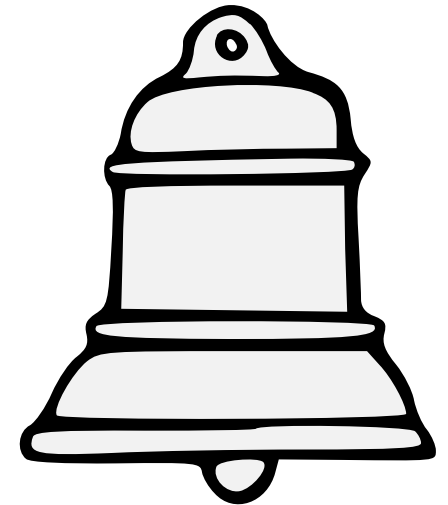
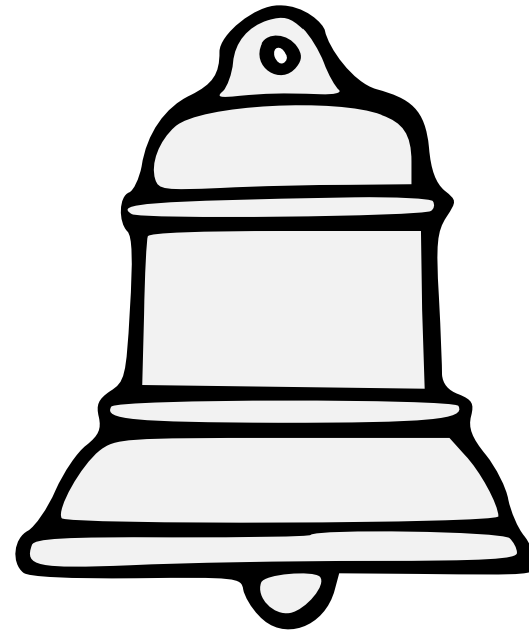
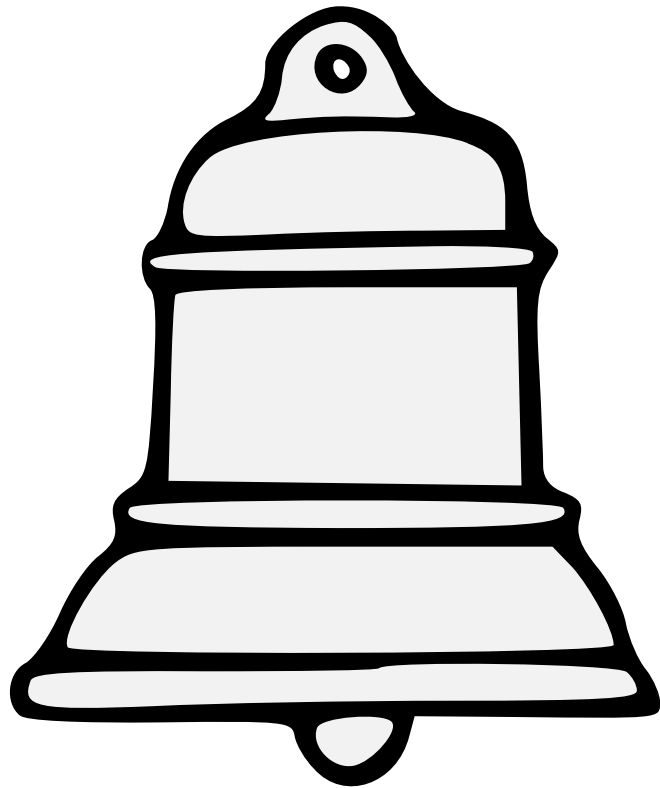

A metal instrument that makes a sound when shaken or hit.

Default orientation: palewise. No proper coloration.

This variety may also be blazoned a "church bell."

Source: Pennsic Traceable Art. Artist unknown.

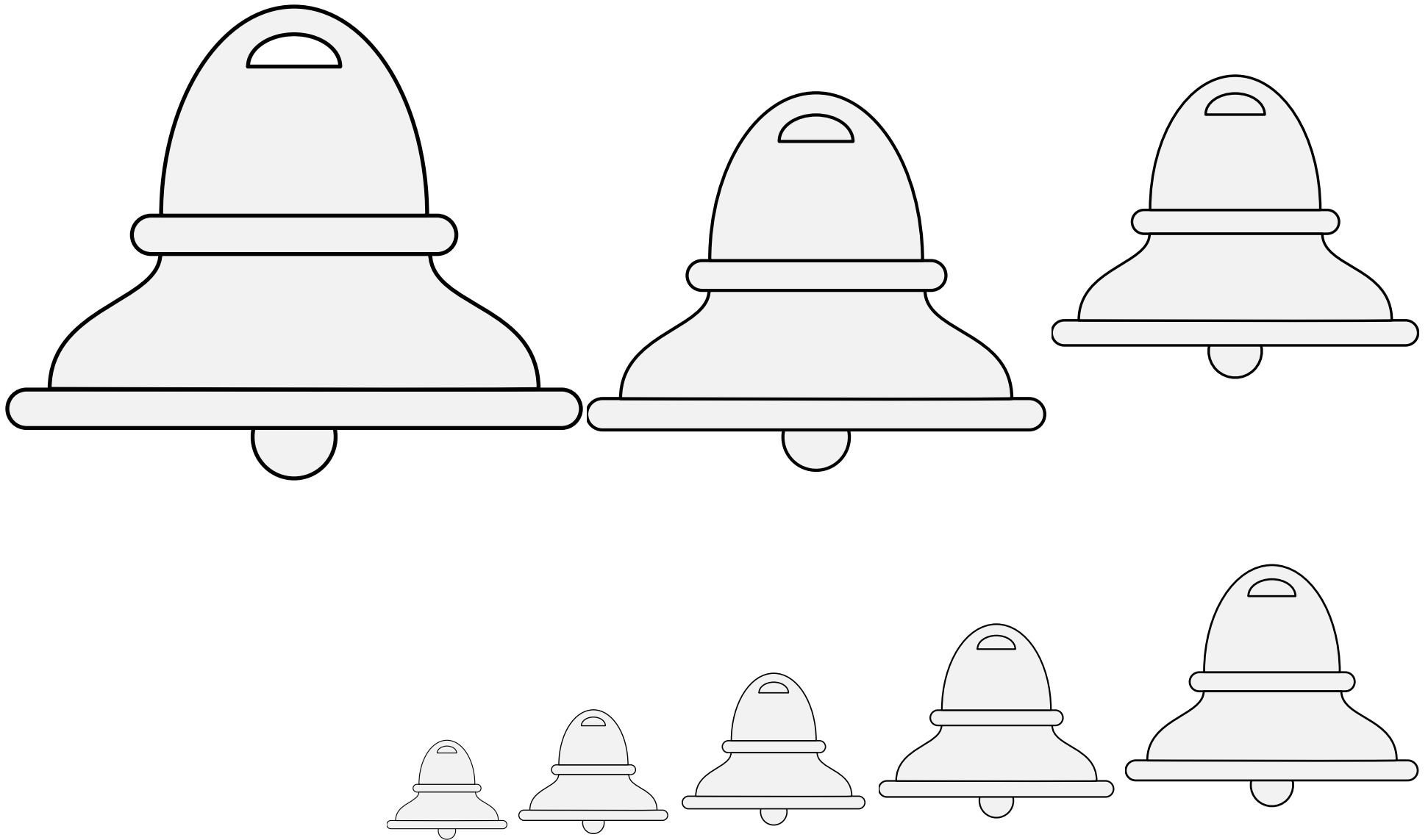

A metal instrument that makes a sound when shaken or hit.

Default orientation: palewise. No proper coloration.

This variety may also be blazoned a “church bell.”

Source: Pennsic Traceable Art. Artist: Unknown.

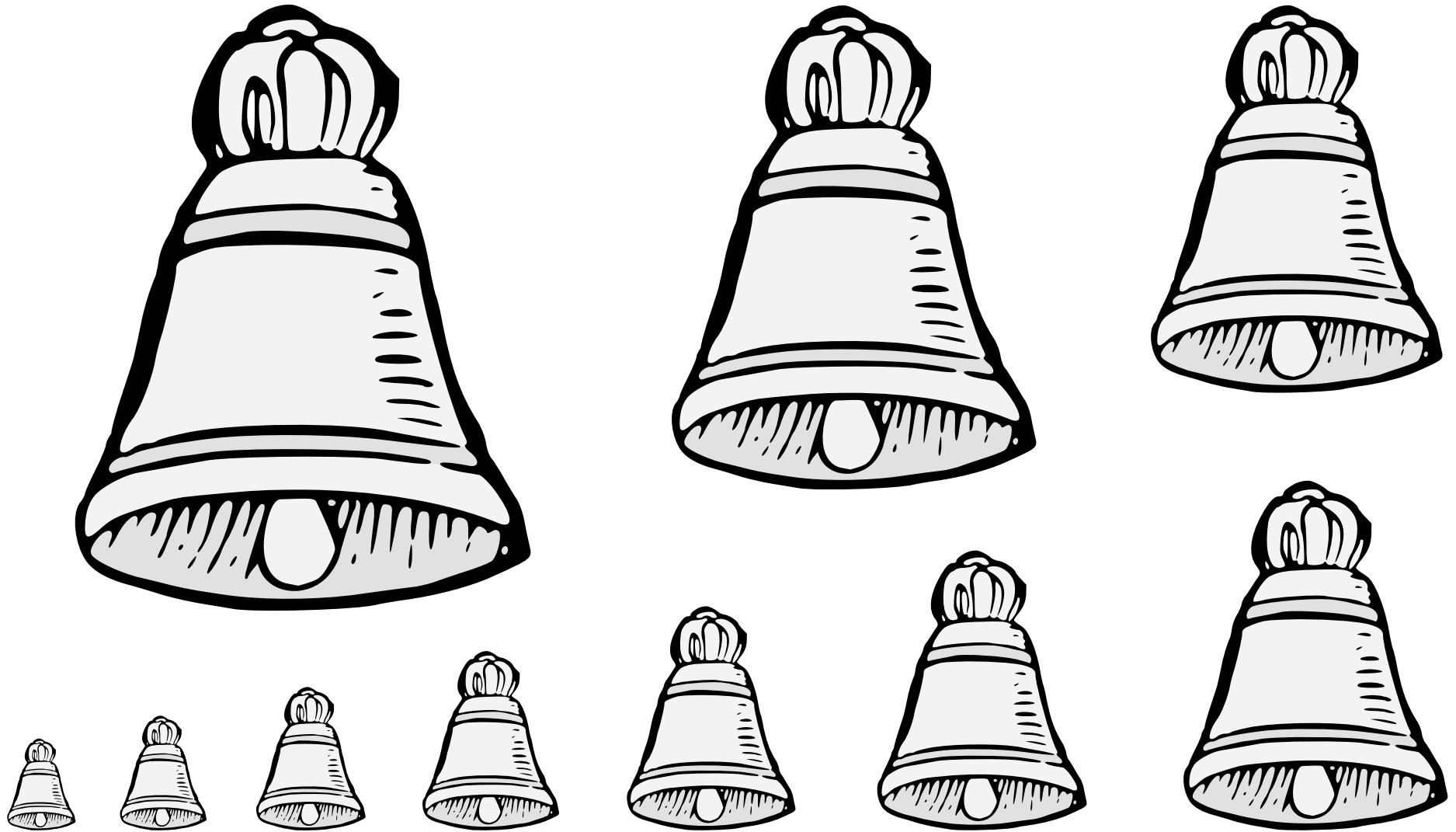

A metal instrument that makes a sound when shaken or hit.

Default orientation: palewise. No proper coloration.

This variety may also be blazoned a “church bell.”

Artist: Iago ab Adam. Adapted from Catalogue des Noms, Surnoms, Faits et Vies.

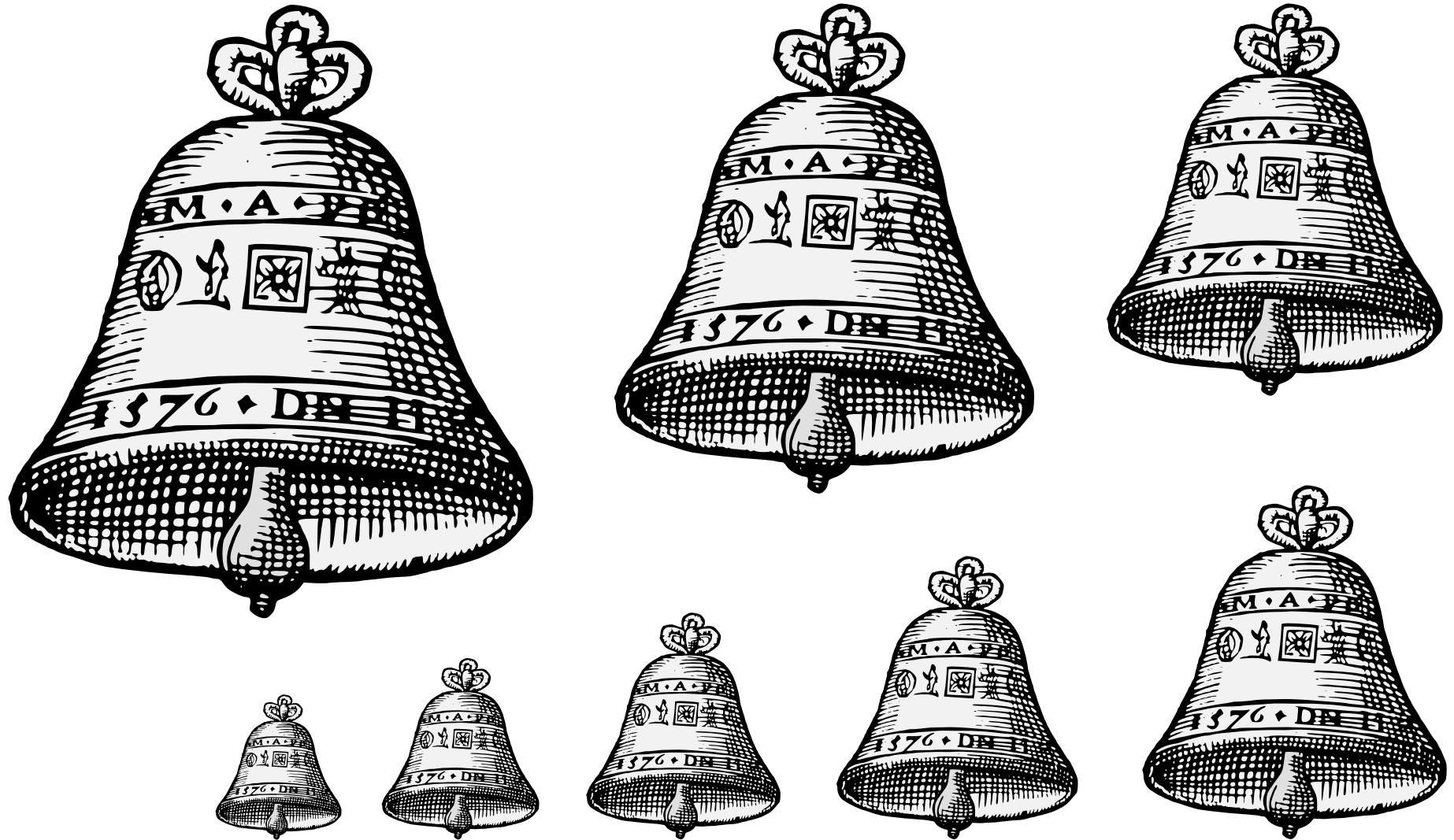

A metal instrument that makes a sound when shaken or hit.

Default orientation: palewise. No proper coloration.

This variety may also be blazoned a “church bell.”

Source: Le Blason Des Armoiries. Artist: Jérôme de Bara. (Page 62.)

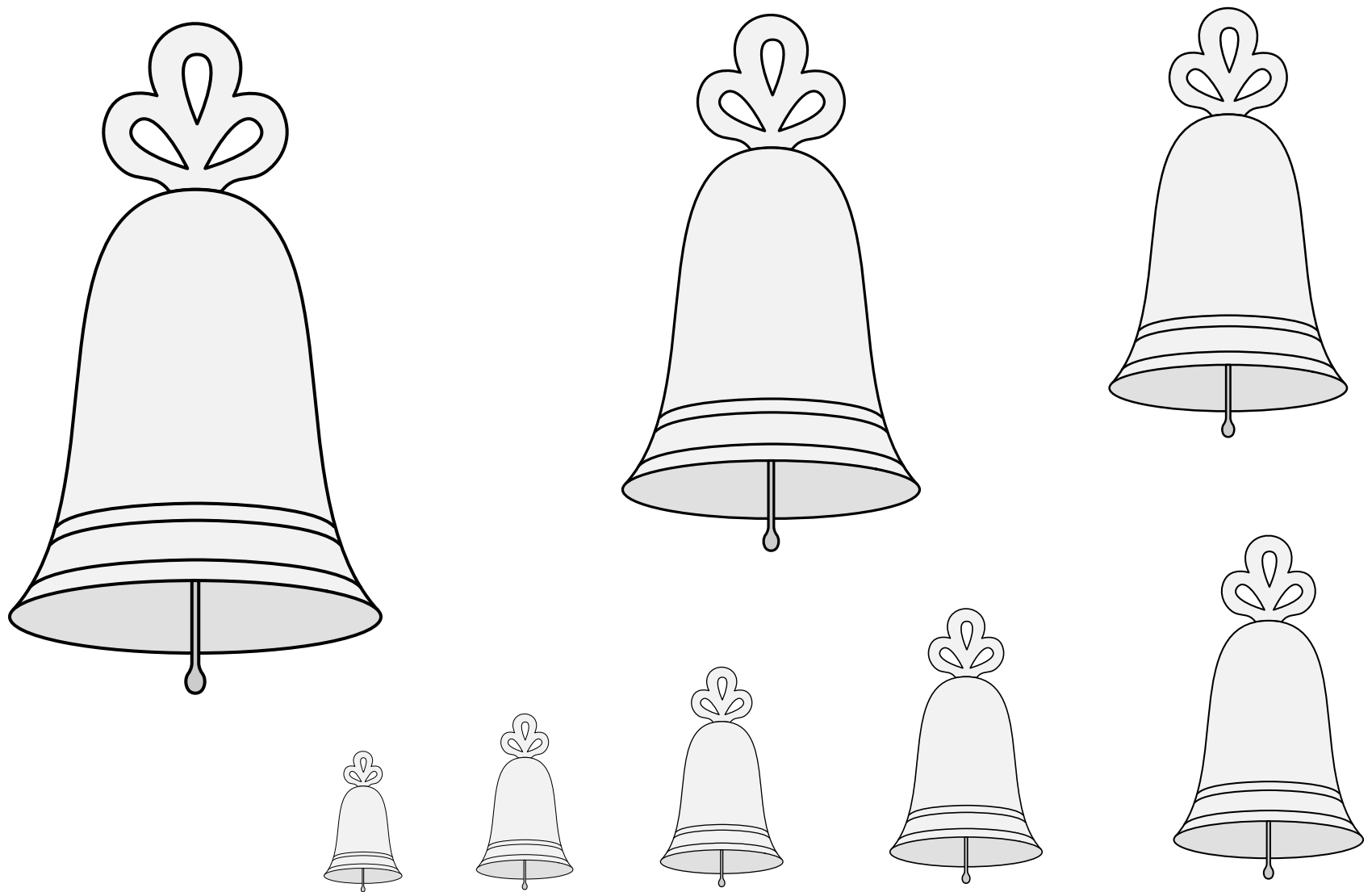

A metal instrument that makes a sound when shaken or hit.

Default orientation: palewise. No proper coloration.

This variety may also be blazoned a “church bell.”

Source: Libro II Della Nazione Normanda.

Artist unknown. (Arms of San Clementi, page 164.)

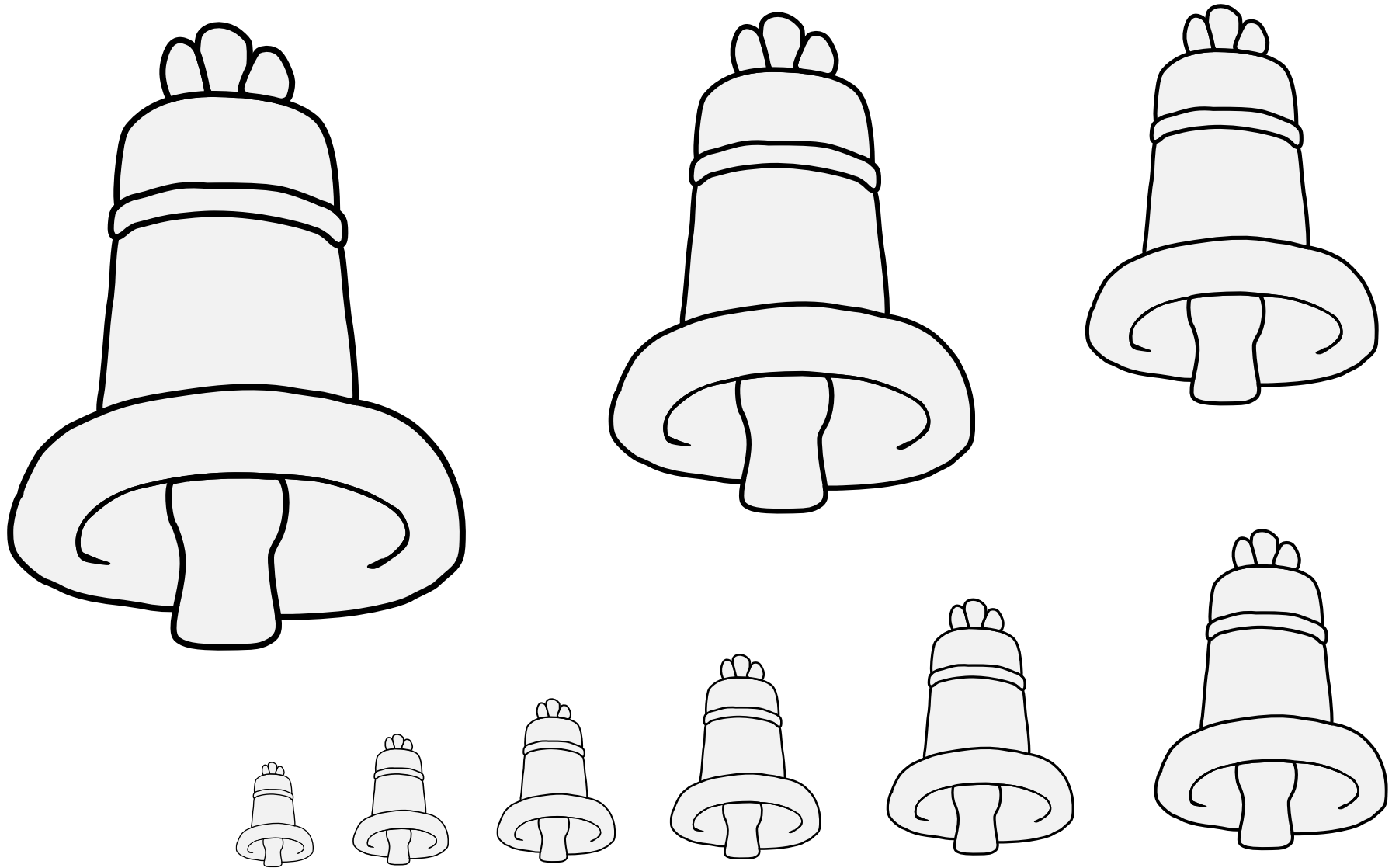

A metal instrument that makes a sound when shaken or hit.

Default orientation: palewise. No proper coloration.

This variety may also be blazoned a “church bell.”

Source: Two Tudor Books of Arms. Artist: Robert Cooke. (From page 31.)



A metal instrument that makes a sound when shaken or hit.

Default orientation: palewise. No proper coloration.

Source: Kenmon Shokamon. Artist unknown. (Page 53.)

Adapted by Jessimond of Emerickeskepe.

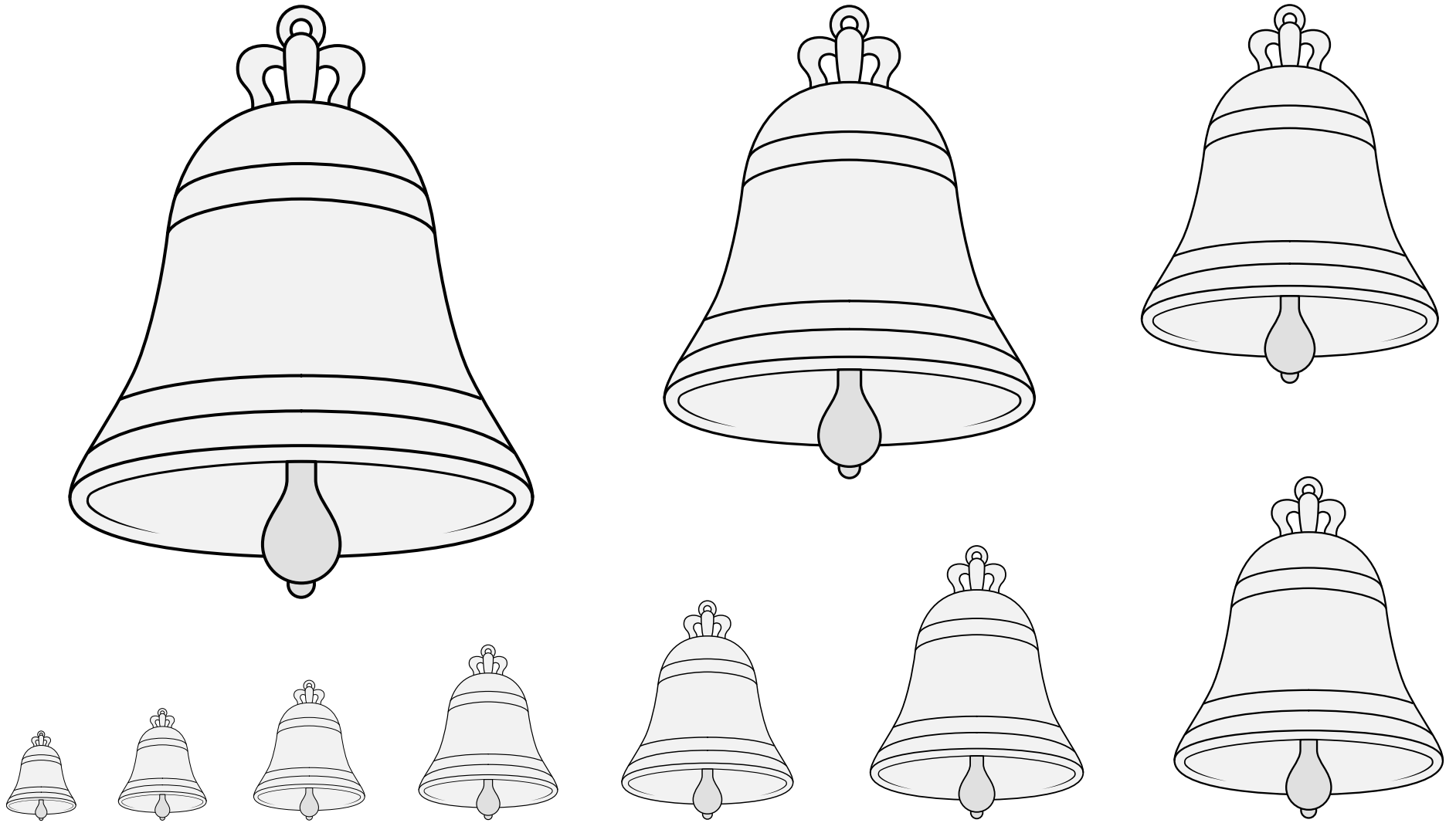

A metal instrument that makes a sound when shaken or hit.

Default orientation: palewise. No proper coloration.

Source: WappenWiki. Artist: Joakim Spuller.

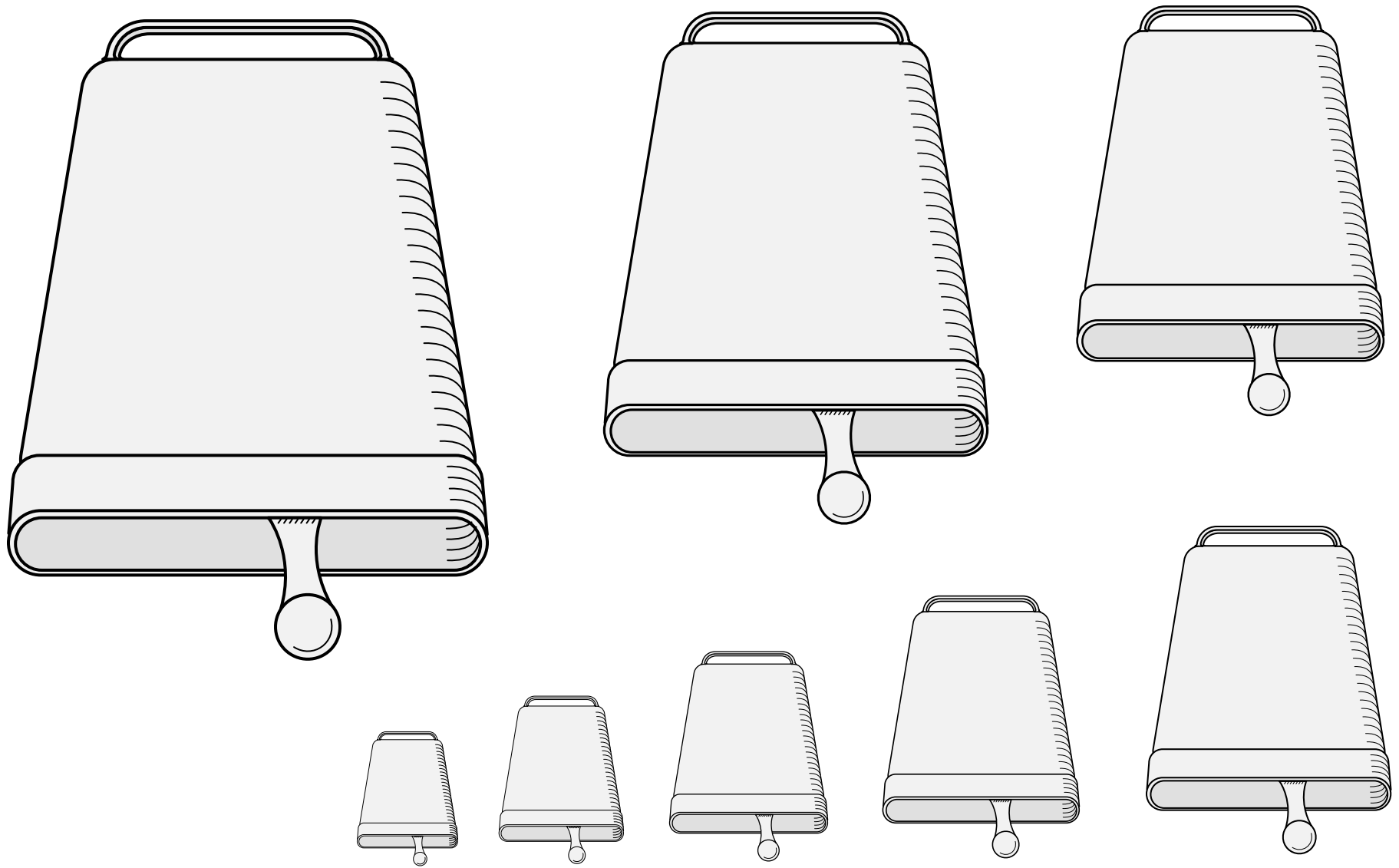

A simple metal bell attached to a cow to aid location of the herd.
Default orientation: upright. No proper coloration.

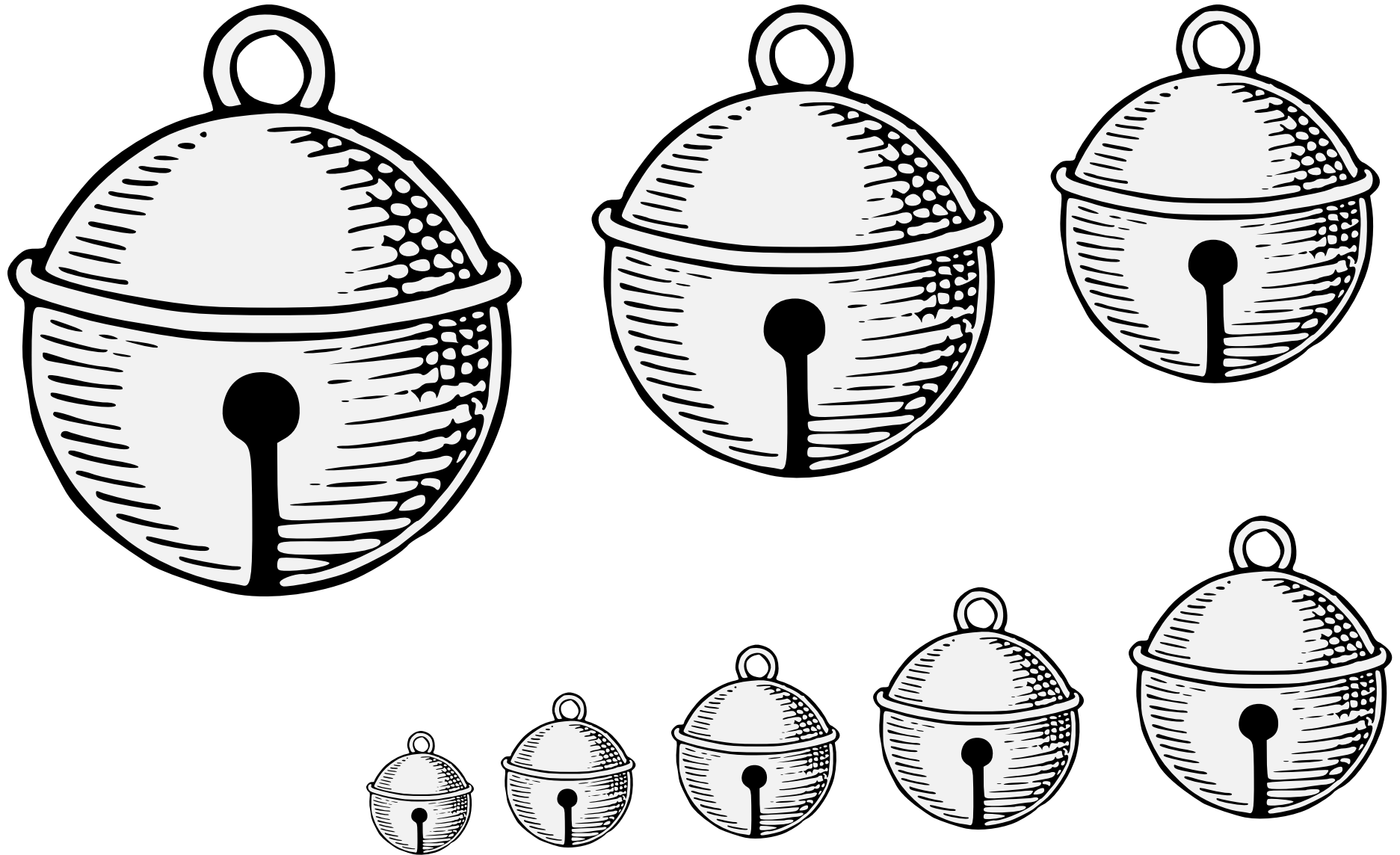

A small bell that could be attached to a hawk's harness.
Source: A Complete Guide to Heraldry. Artist: Graham Johnston.

Bell, Hawk's (1) 18.26

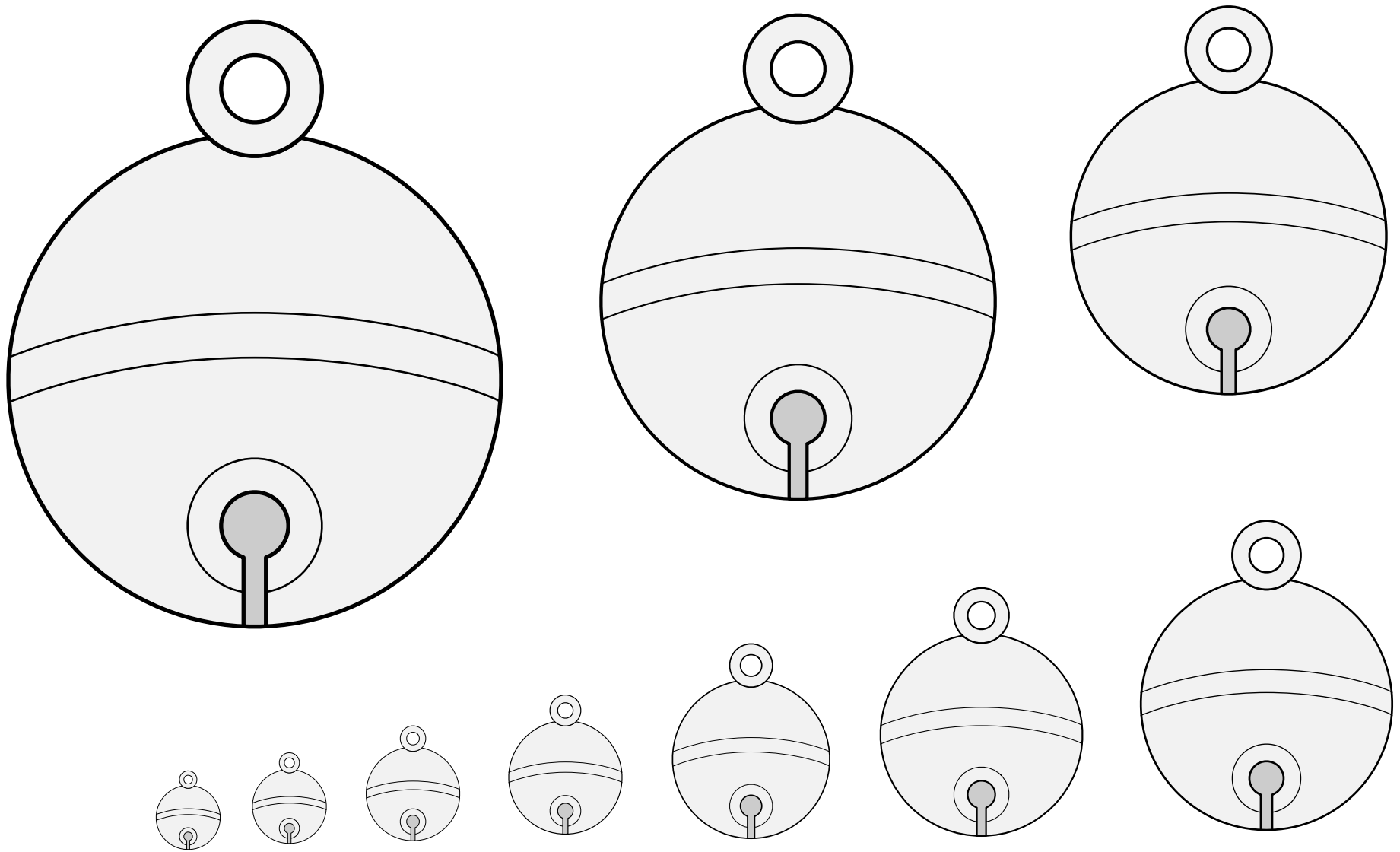

A small bell that could be attached to a hawk's harness.

Source: Armorial de Gelre. Artist: Claes Heinenzoon. (Page 209.)

Bell, Hawk's (2) 18.27

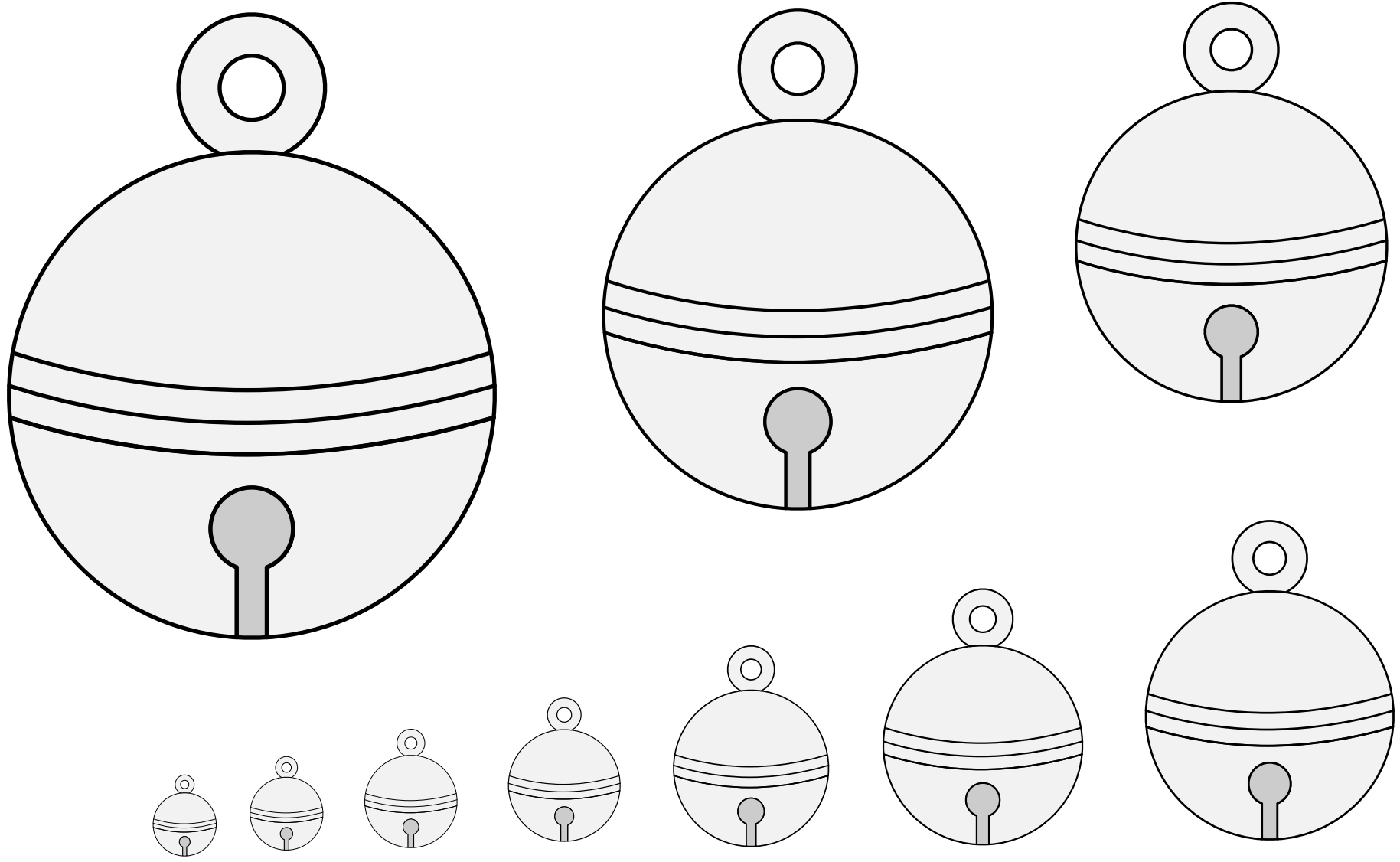

A small bell that could be attached to a hawk's harness.
Source: Lewis Armorial. Artist unknown. (Folio 11r.)

Bell, Hawk's (3) 18.28

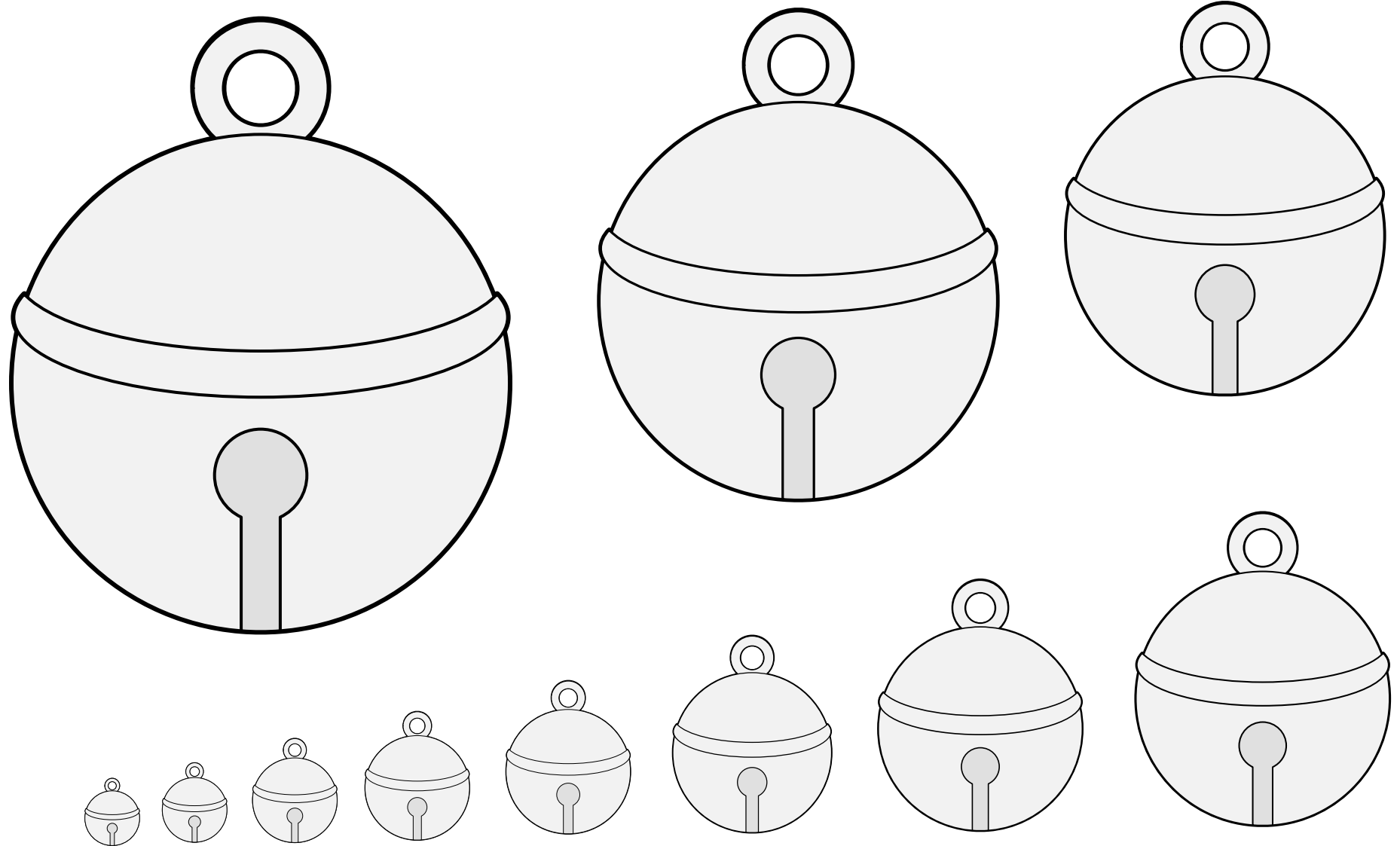

A small bell that could be attached to a hawk's harness.

Default orientation: loop to chief. No proper coloration.

Source: Viking Answer Lady SVG Images For Heraldry. Artist: Gunnvôr silfráhr.

Bell, Hawk's (4) 18.29

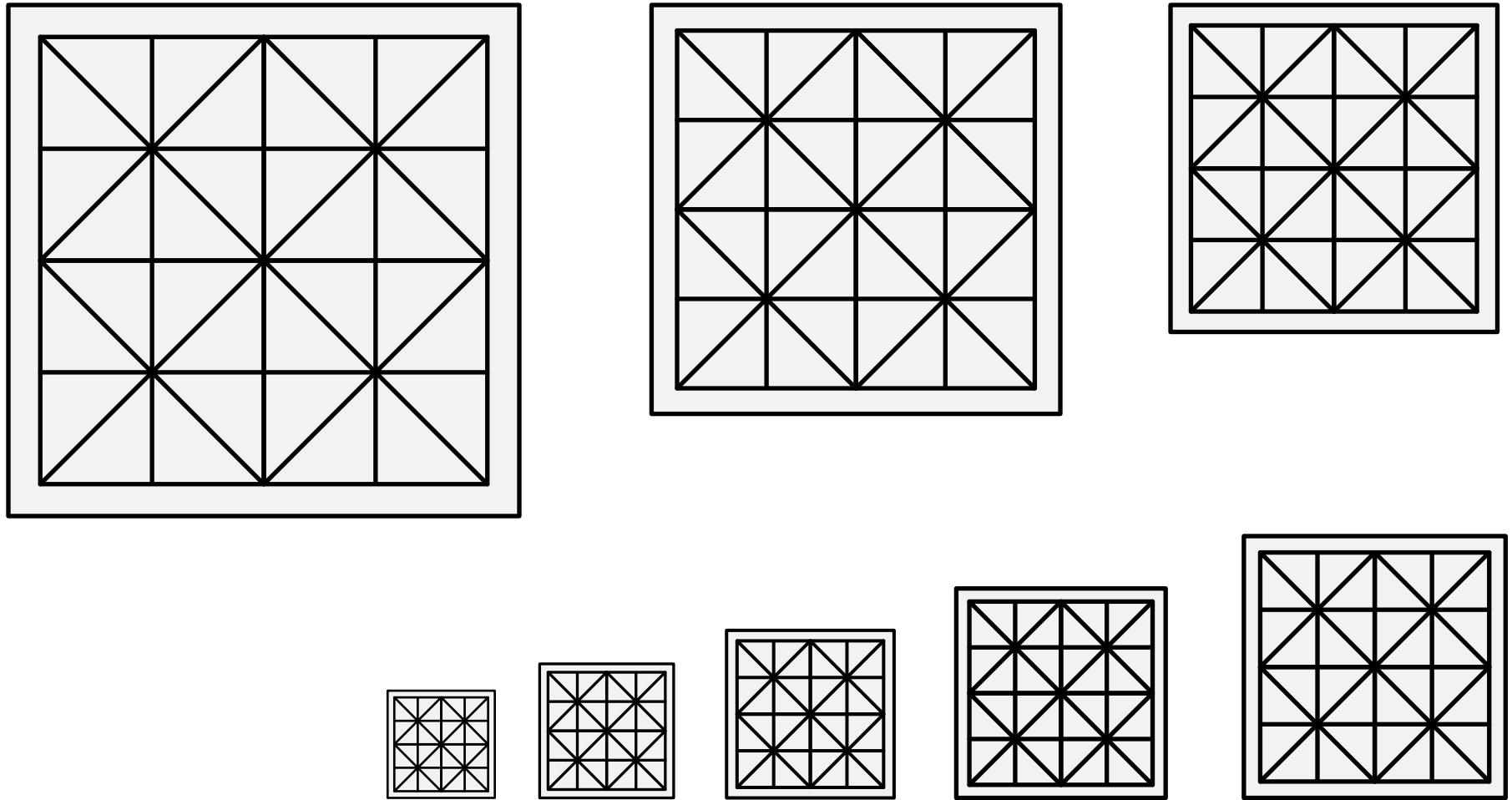

A board for playing the 11th century Middle-Eastern game of Alquerque, or Qirkat, a game that preceded checkers. Brought to Spain by the Moors in the 13th C.

Attested period artifact, but not used in any period armory, nor yet registered in the SCA.

The lines must contrast with the board to be visible, and are blazoned separately, "an alquerque board *tincture* marked *tincture*."

Source: Pennsic Traceable Art. Artist unknown.

Adapted by Mathghamhain Ua Ruadháin.

Board, Alquerque 18.30

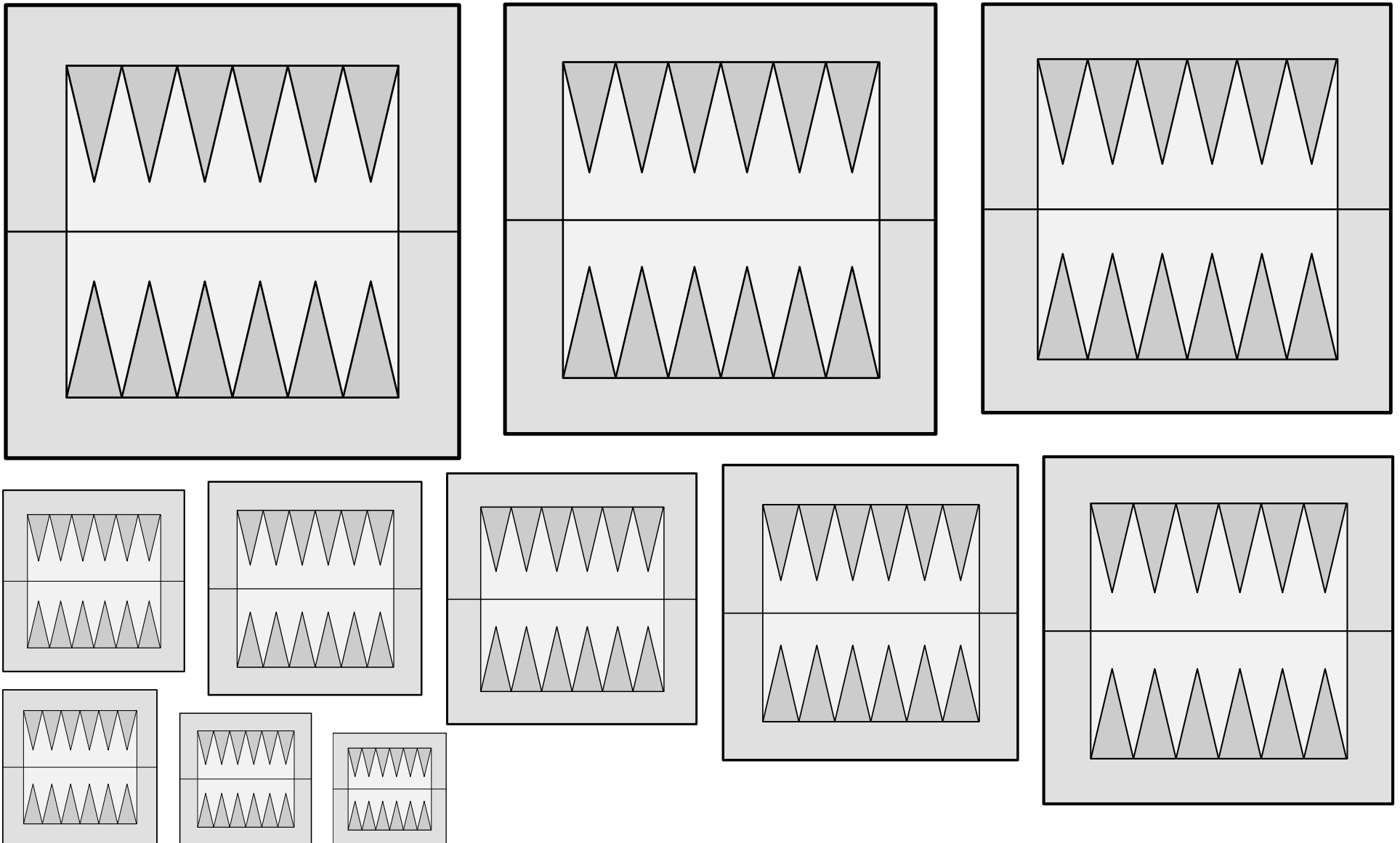

A board on which to play the game of nardshir.

Default orientation: flat side to base. No proper coloration.

Source: Wappenbuch of the Holy Roman Empire.
Artist unknown. (Page 774.)

Board, Backgammon (1) 18.31

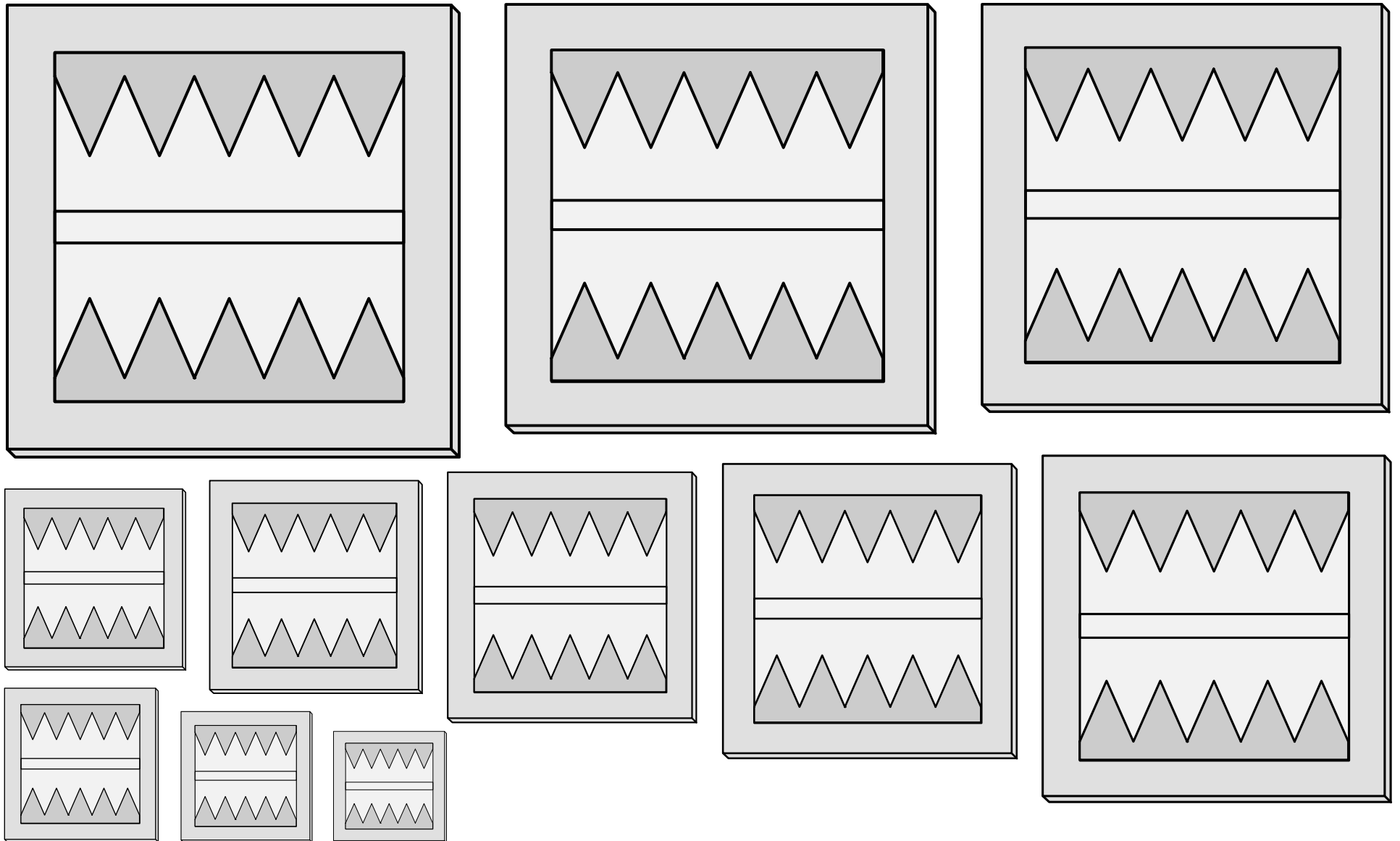

A board on which to play the game of nardshir.

Default orientation: flat side to base. No proper coloration.

Source: Wappenbuch Fol 223. (Folio 65v.) Artist unknown.
Adapted by Mathghamhain Ua Ruadháin.

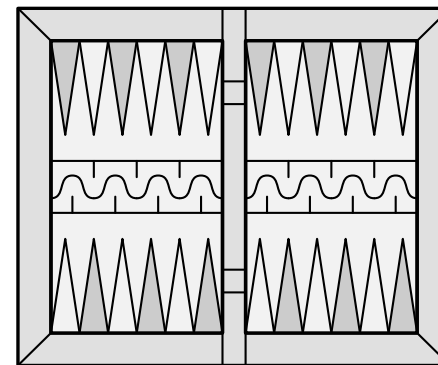
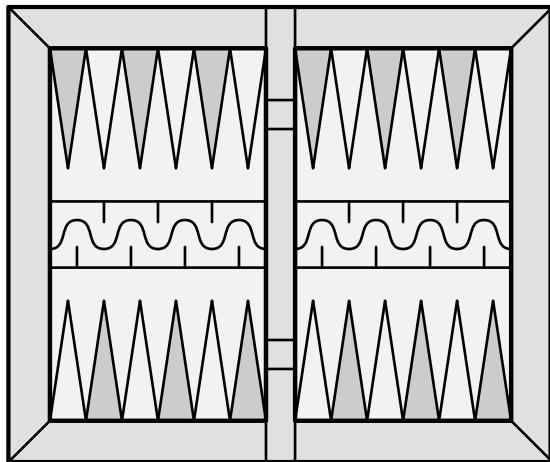
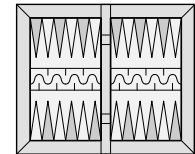
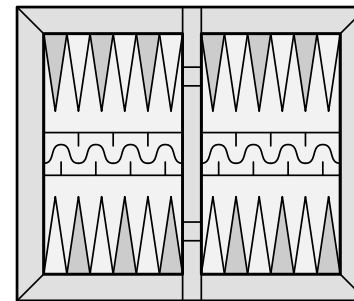
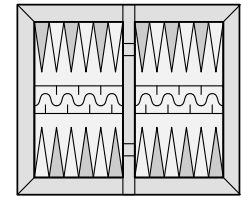
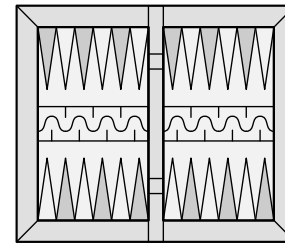
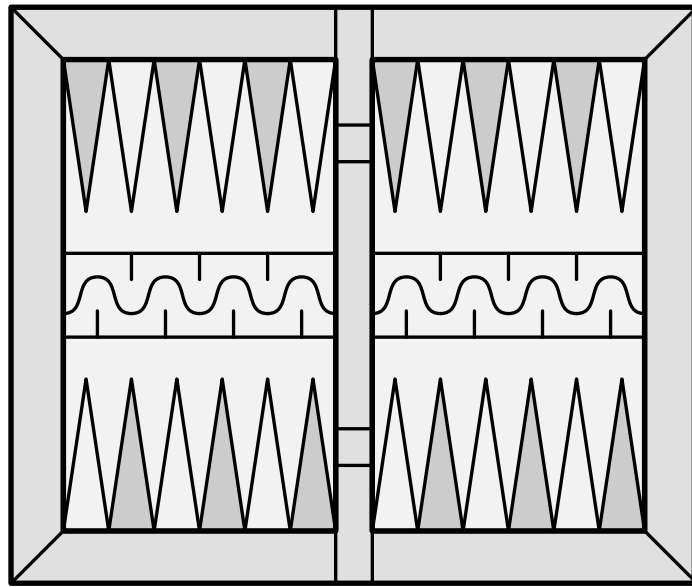

A board on which to play the game of nardshir.

Default orientation: flat side to base. No proper coloration.

Source: Guillim's Display of Heraldry.

Artist unknown. (Edition of 1638, page 320.)

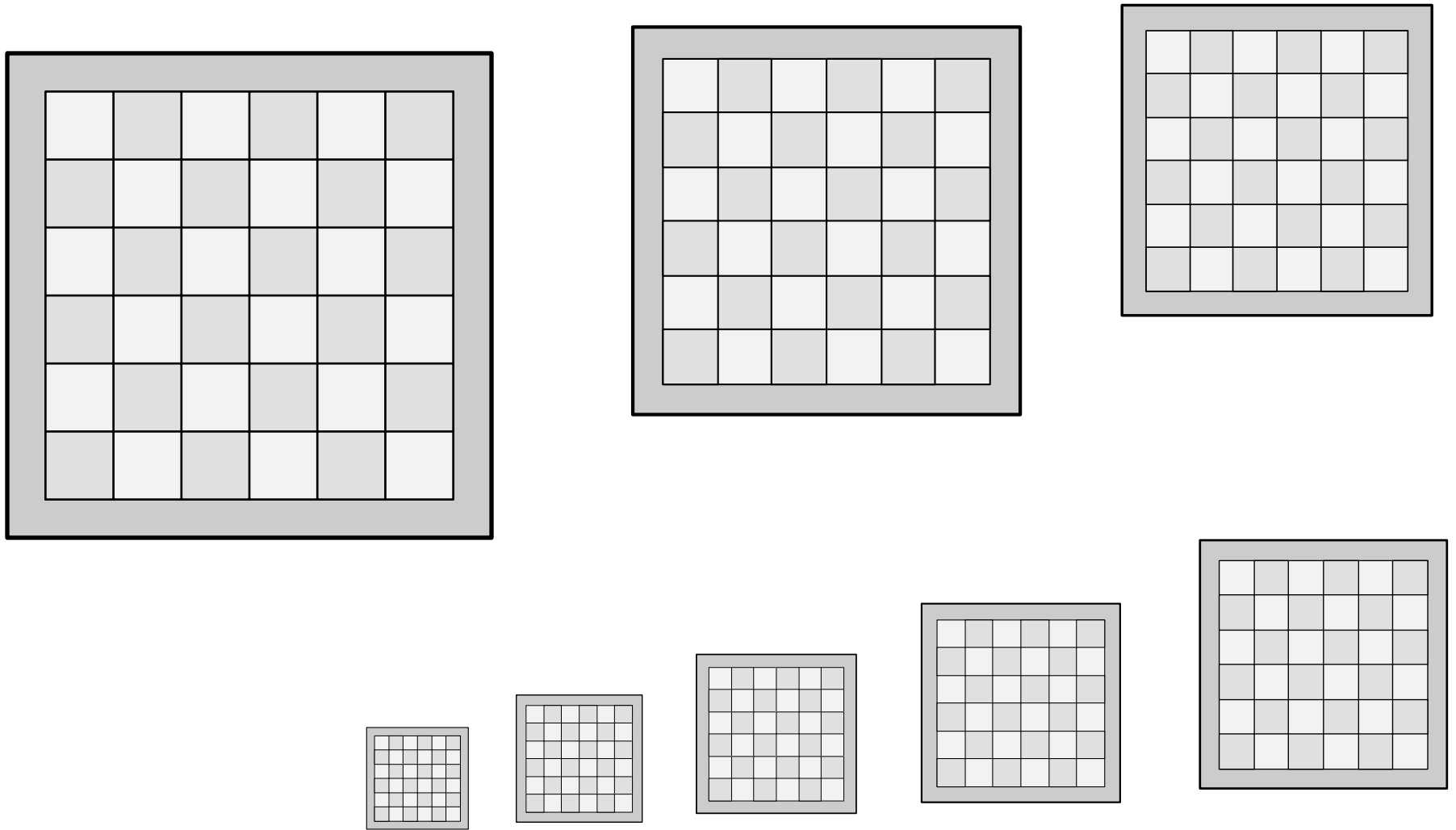

A board on which to play the game of chesse.

Source: Wappenbuch of the Holy Roman Empire.
Artist unknown. (Page 711.)

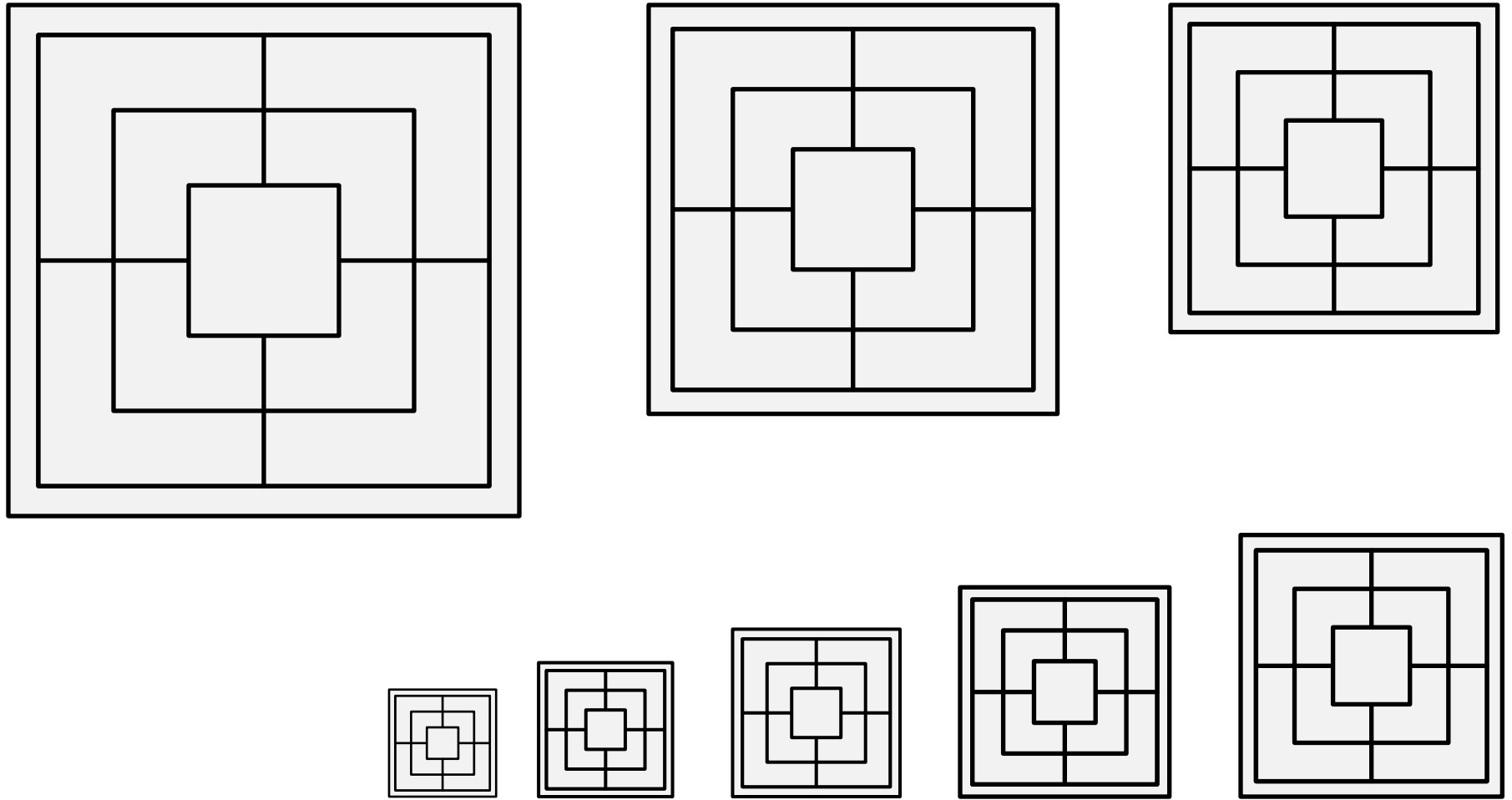

A board for playing the ancient game of Nine Men's Morris.

Dated to the Roman Empire, if not before.

The lines must contrast with the board to be visible, and are blazoned separately, "a nine men's morris board *tincture* marked *tincture*."

Attested period artifact, but not used in any period armory.

Board, Nine Men's Morris 18.35

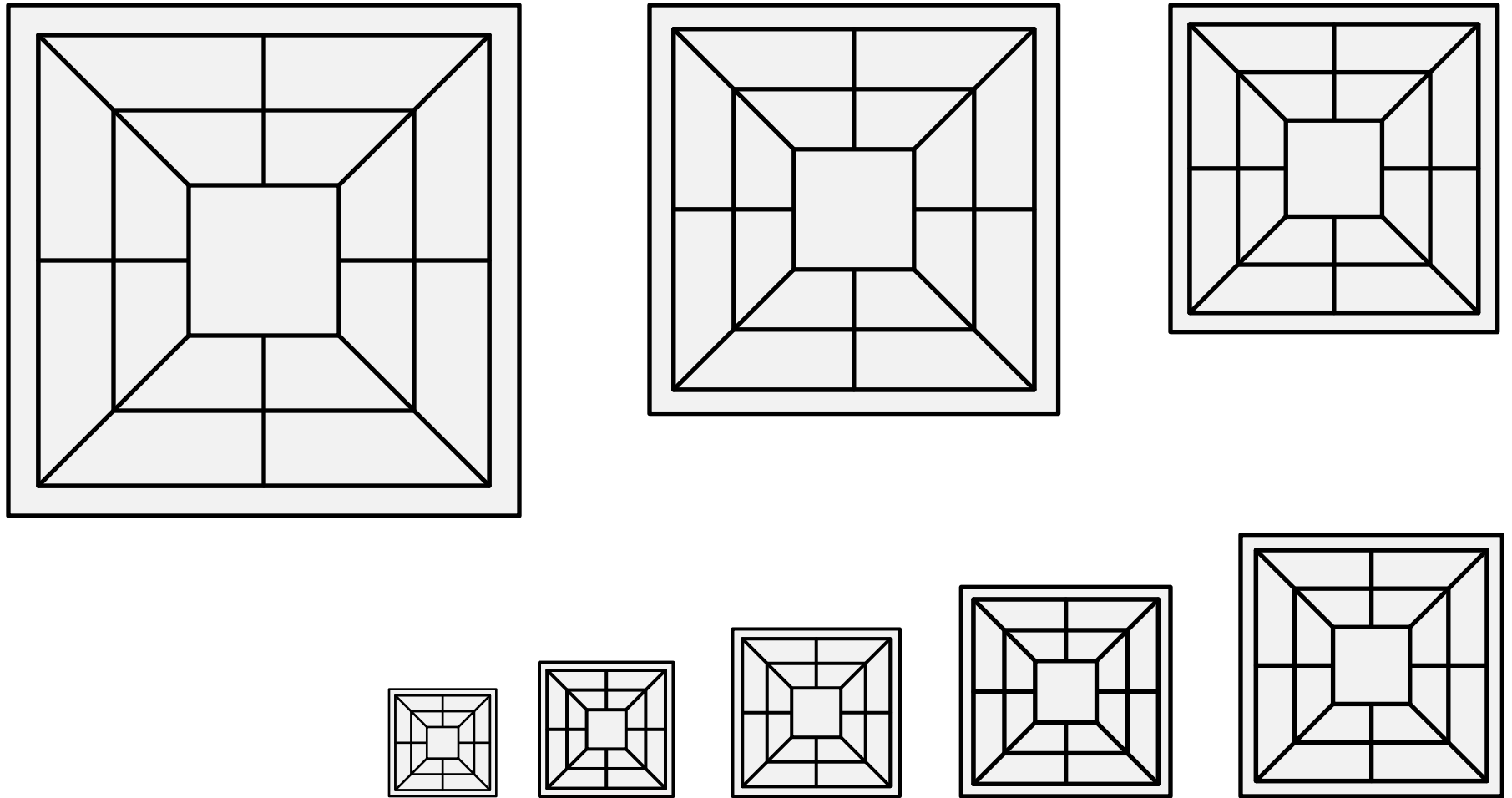

A board for playing the ancient game of Twelve Men's Morris.

Known as Morabaraba in southern Africa.

The lines must contrast with the board to be visible, and are blazoned separately, "a twelve men's morris board *tincture* marked *tincture*."

Attested period artifact, but not used in any period armory.

Board, Twelve Men's Morris 18.36

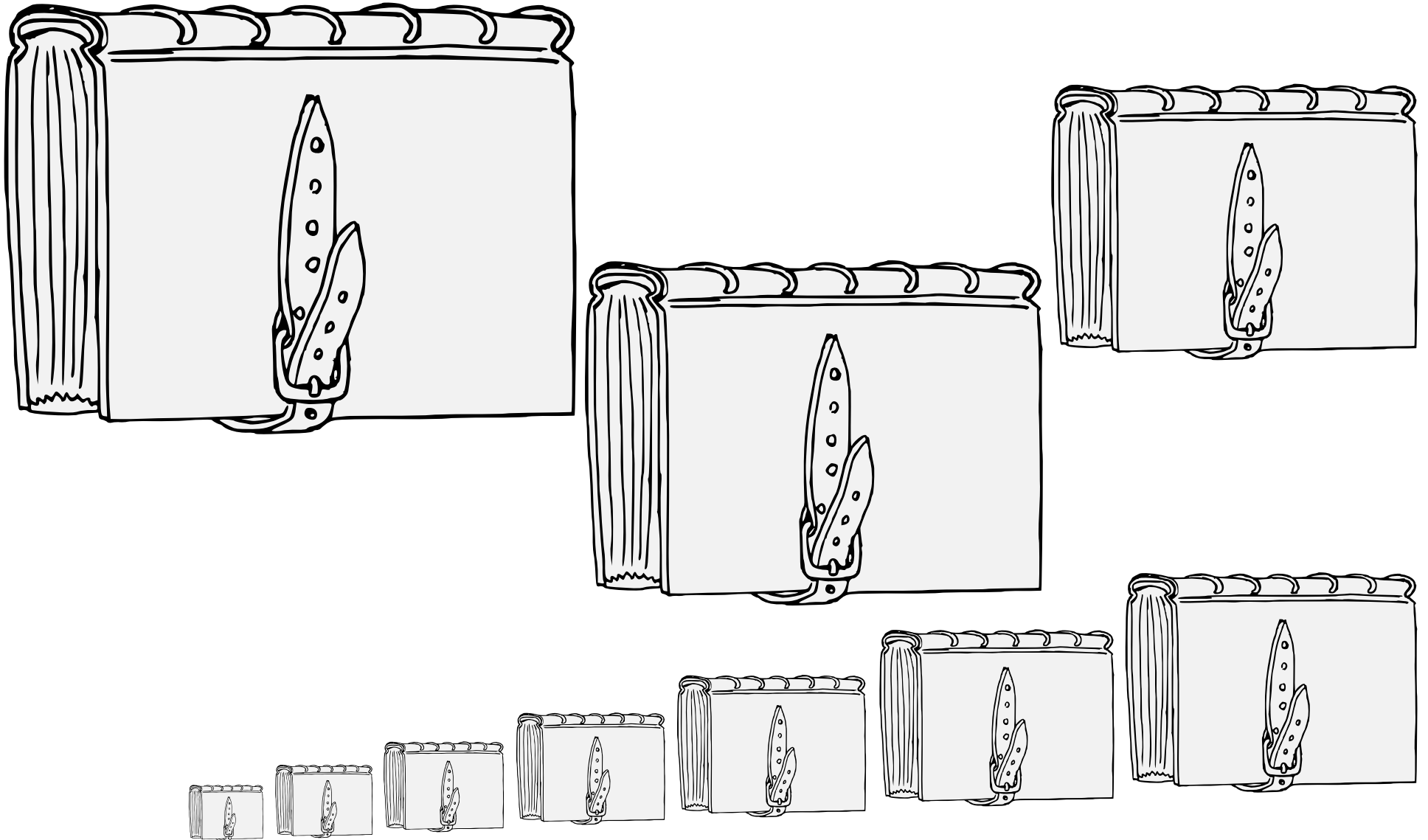

A bound collection of pages.

Default orientation: spine to chief. Proper coloration: argent pages, brown leather cover.

Source: Pennsic Bored-Artist Collection. Artist unknown.

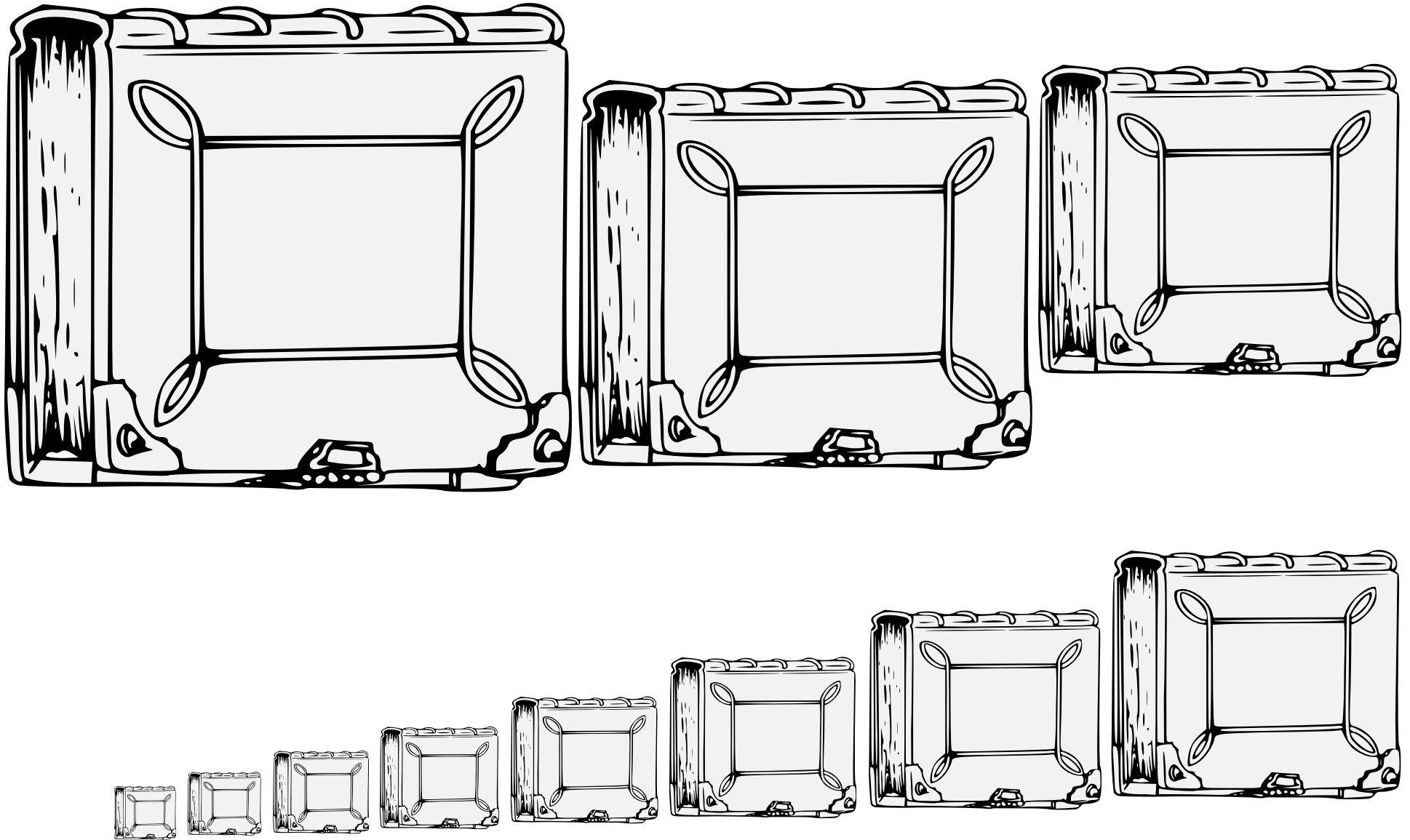

A bound collection of pages.

Default orientation: spine to chief. Proper coloration: argent pages, brown leather cover.

Source: Heraldic Templates. Artist: Torric inn Björn.

Book, Closed (2) • 18.38

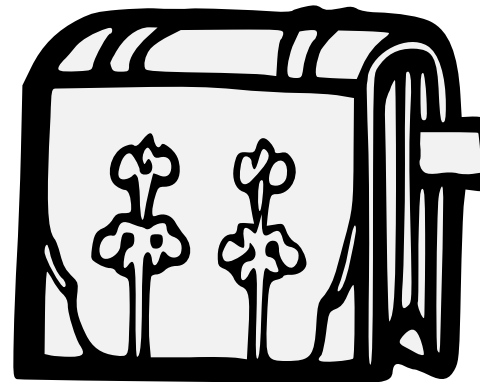
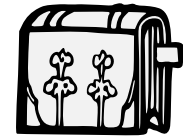
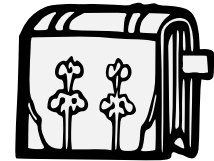
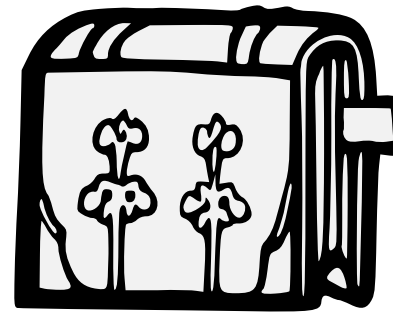
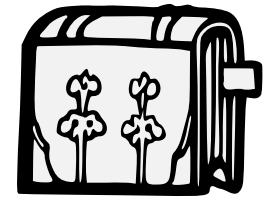
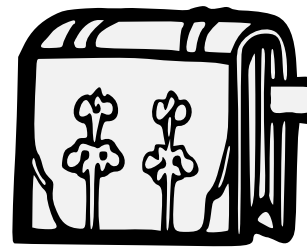
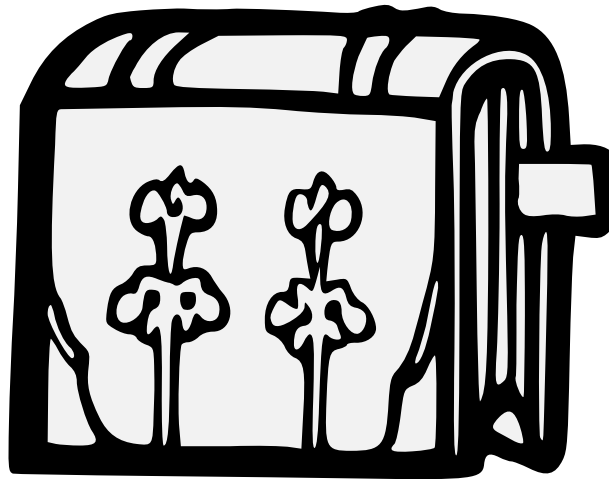
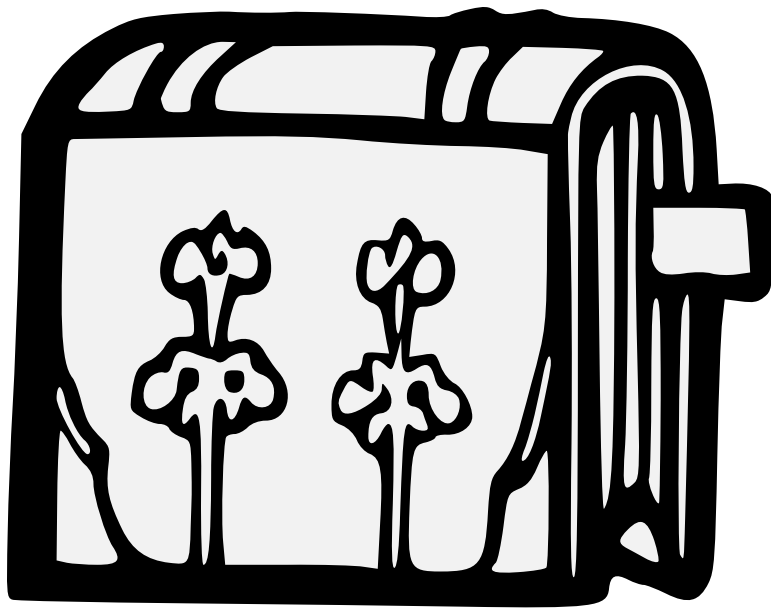

A bound collection of pages.

Default orientation: spine to chief. Proper coloration: argent pages, brown leather cover.

Source: Pennsic Traceable Art. Artist: Unknown.

Book, Closed (3) • 18.39

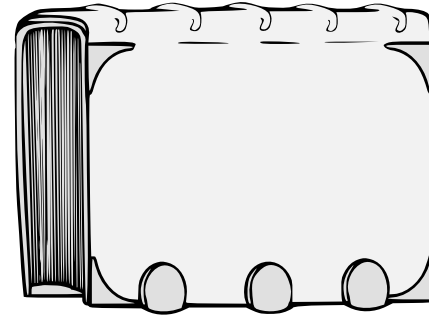
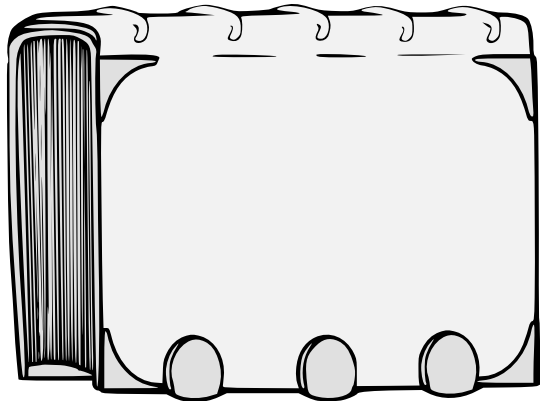
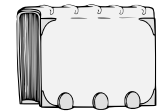
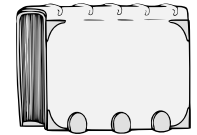
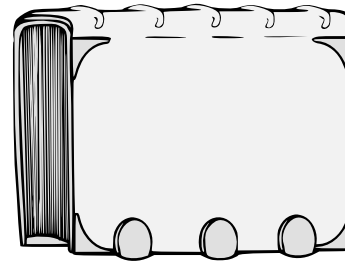
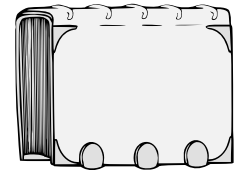
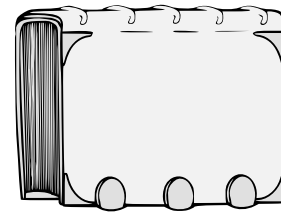
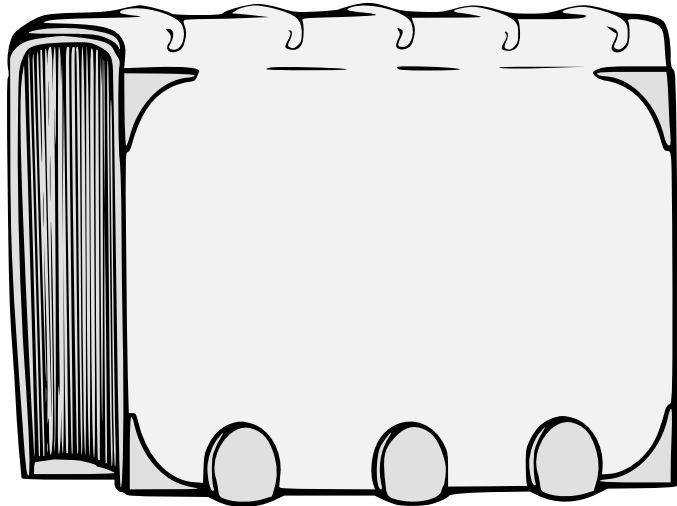

A bound collection of pages.

Default orientation: spine to chief. Proper coloration: argent pages, brown leather cover.

Artist: Jessimond of Emerickeskepe.

Book, Closed (4) 18.40

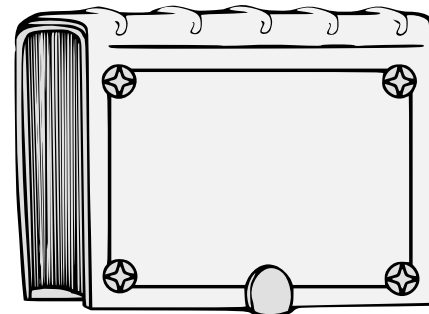
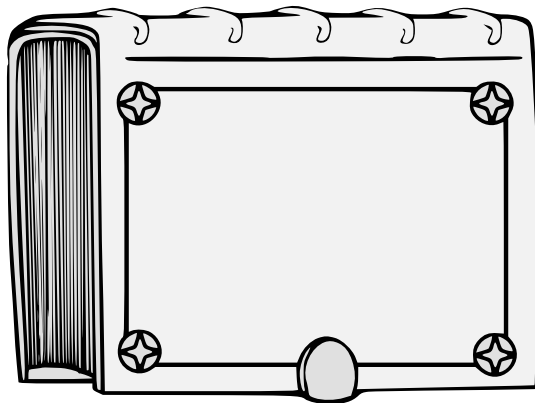
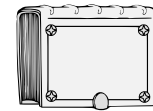
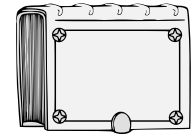
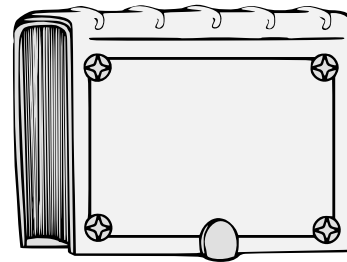
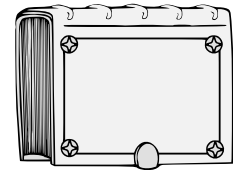
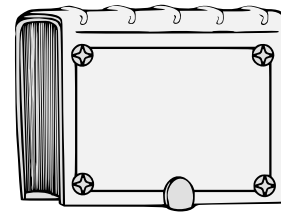
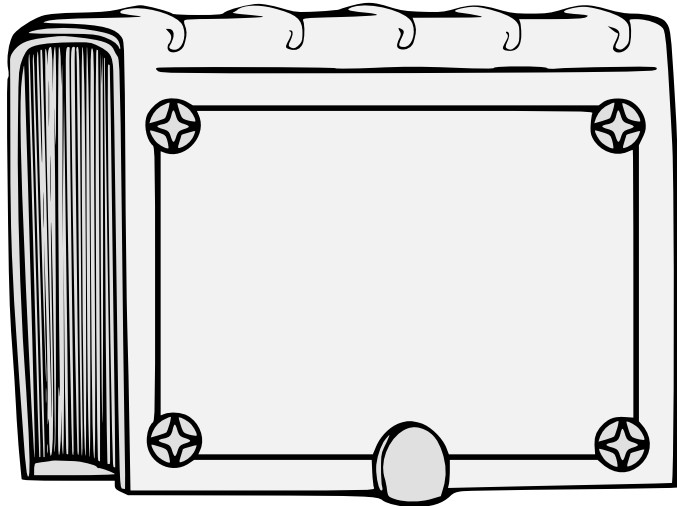

A bound collection of pages.

Default orientation: spine to chief. Proper coloration: argent pages, brown leather cover.

Artist: Jessimond of Emerickeskepe.

Book, Closed (5) 18.41

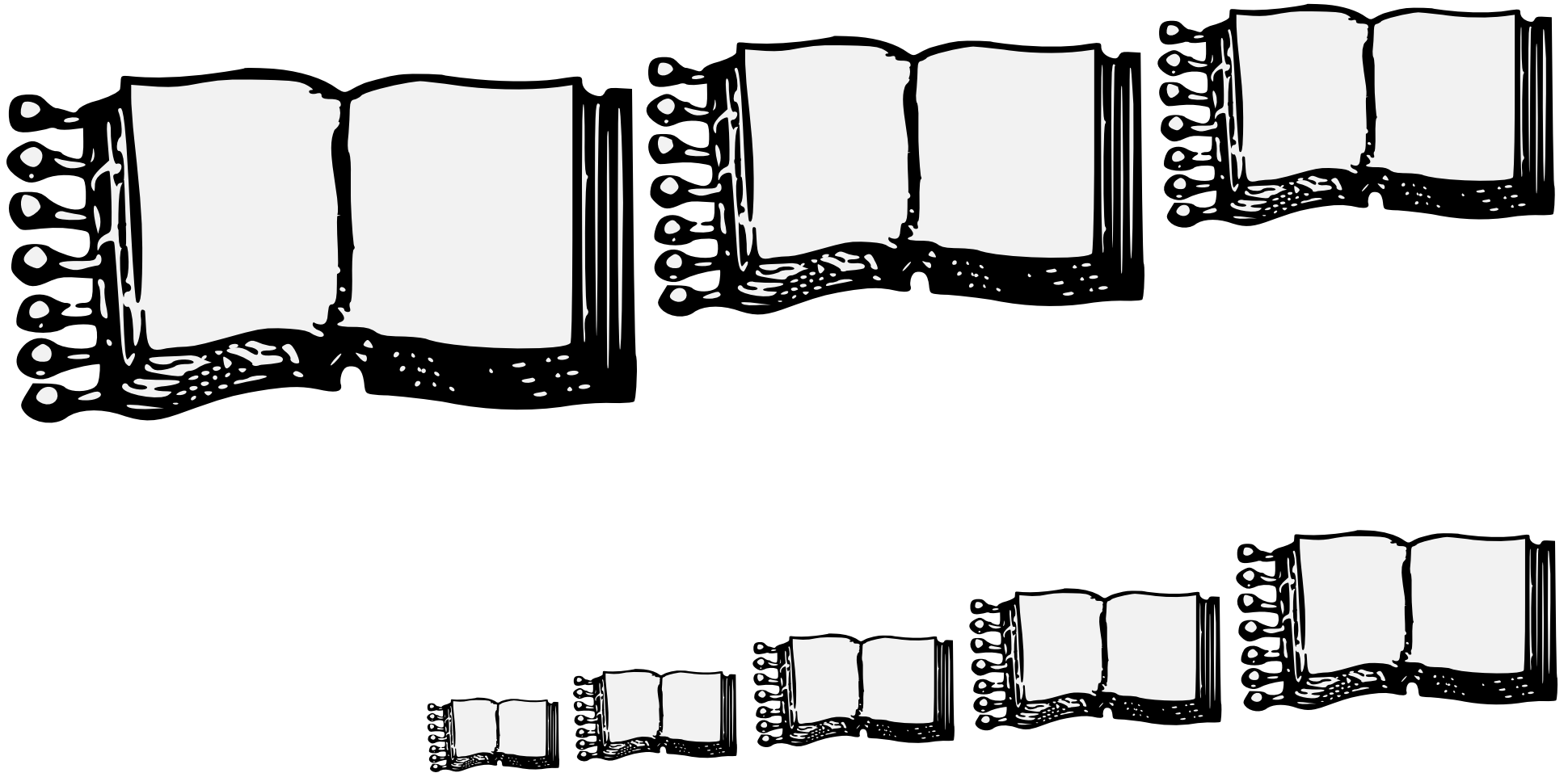

A bound collection of pages. Pages may be marked with letters or symbols.

Default orientation: fesswise. Proper coloration: argent pages, brown leather cover.

Source: Guillim's Display of Heraldry. Artist unknown.

Book, Open (1) 18.42

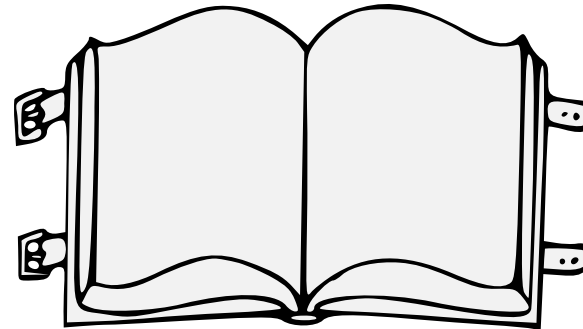
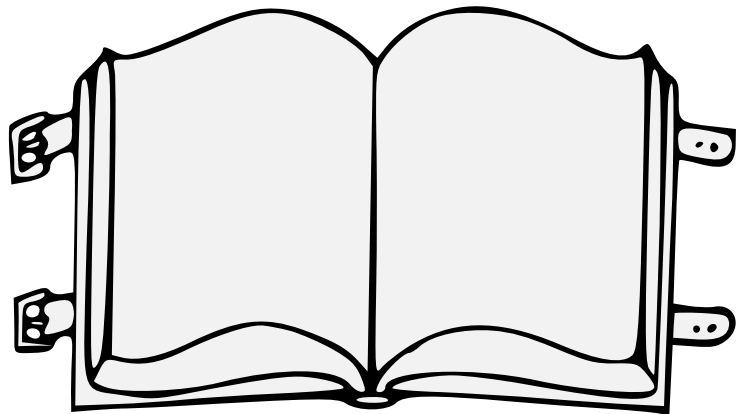
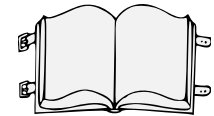
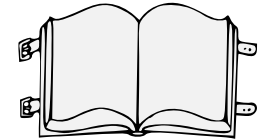
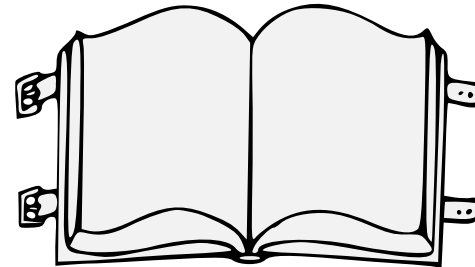
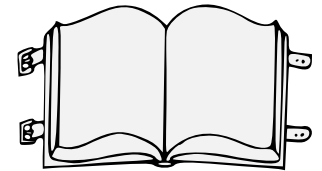
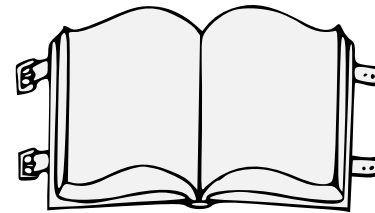
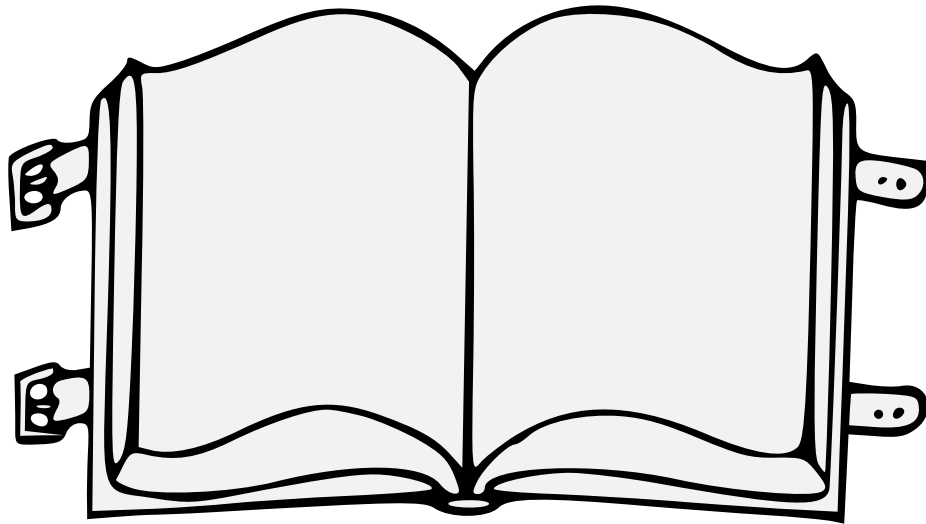

A bound collection of pages. Pages may be marked with letters or symbols.
Default orientation: fesswise. Proper coloration: argent pages, brown leather cover.
Source: Pennsic Traceable Art. Artist: Roana d'Evreux.

Book, Open (2) 18.43

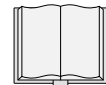
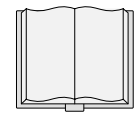
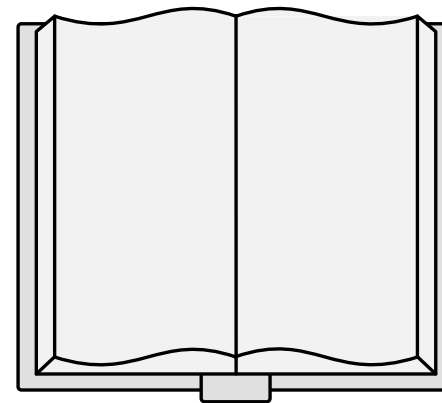
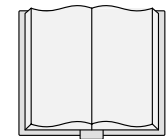
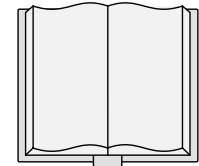
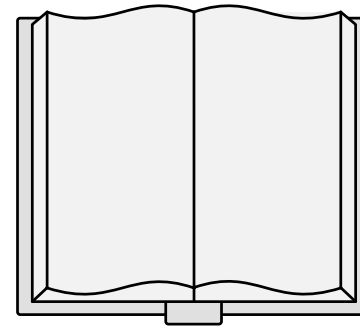
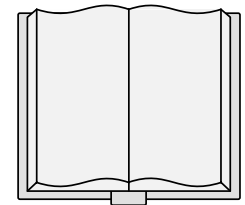
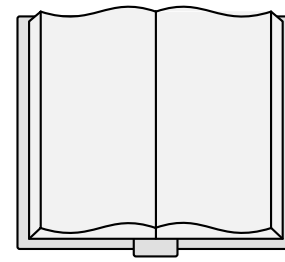
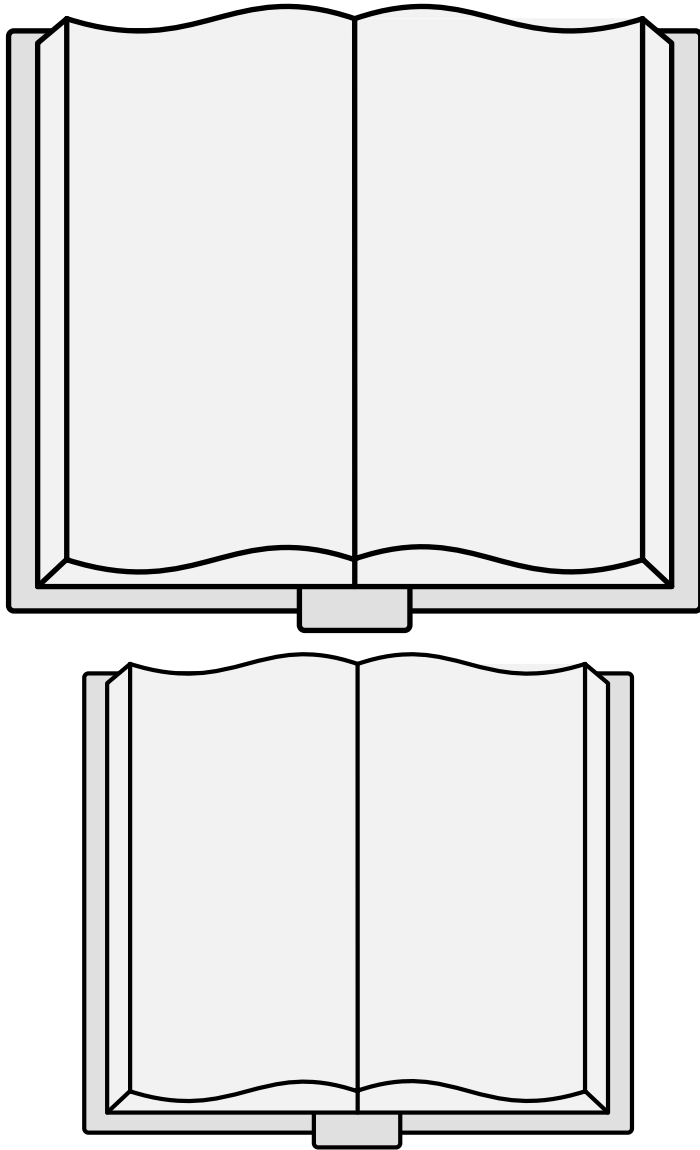

A bound collection of pages. Pages may be marked with letters or symbols.
Default orientation: fesswise. Proper coloration: argent pages, brown leather cover.
Source: SVG Heraldry Components. Artist: Nicholas de Estleche.

Book, Open (3) 18.44

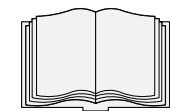
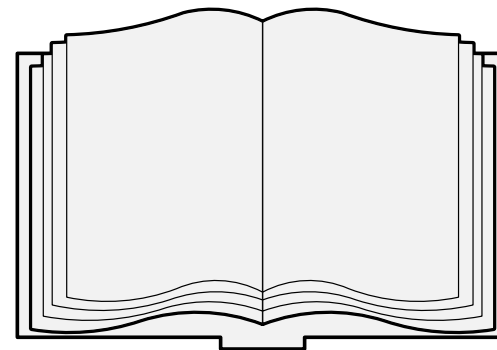
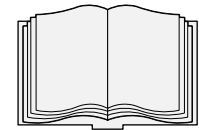
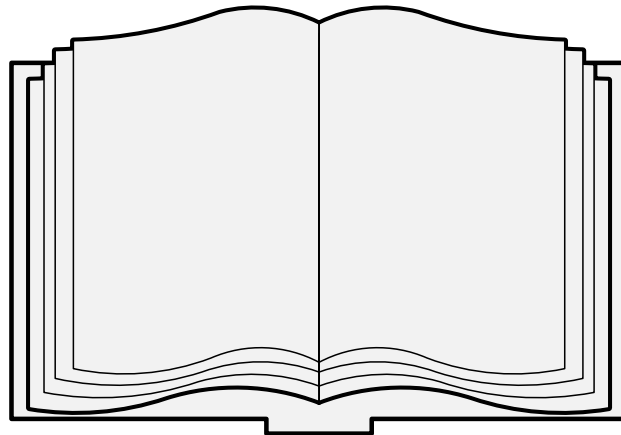
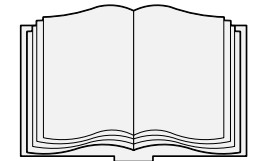
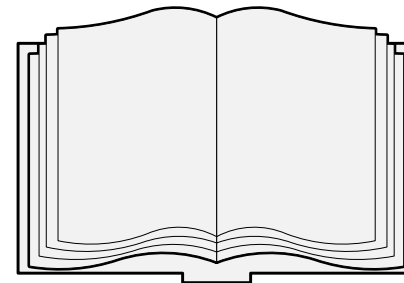
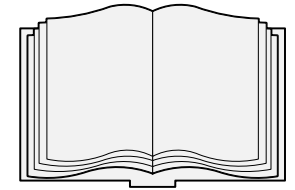
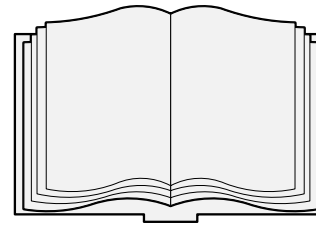
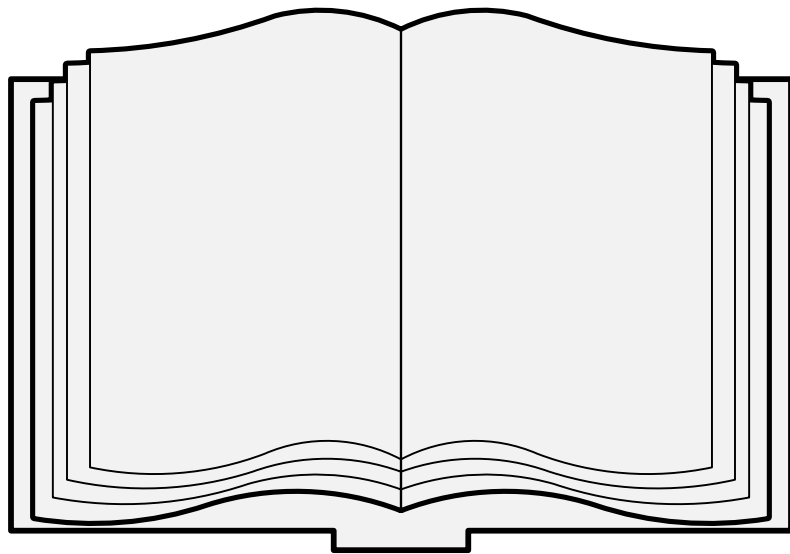

A bound collection of pages.

Pages may be marked with letters or symbols.

Default orientation: fesswise. Proper coloration: argent pages, brown leather cover.

Source: Viking Answer Lady SVG Images For Heraldry. Artist: Gunnvôr silfráhr.

Book, Open (4) 18.45

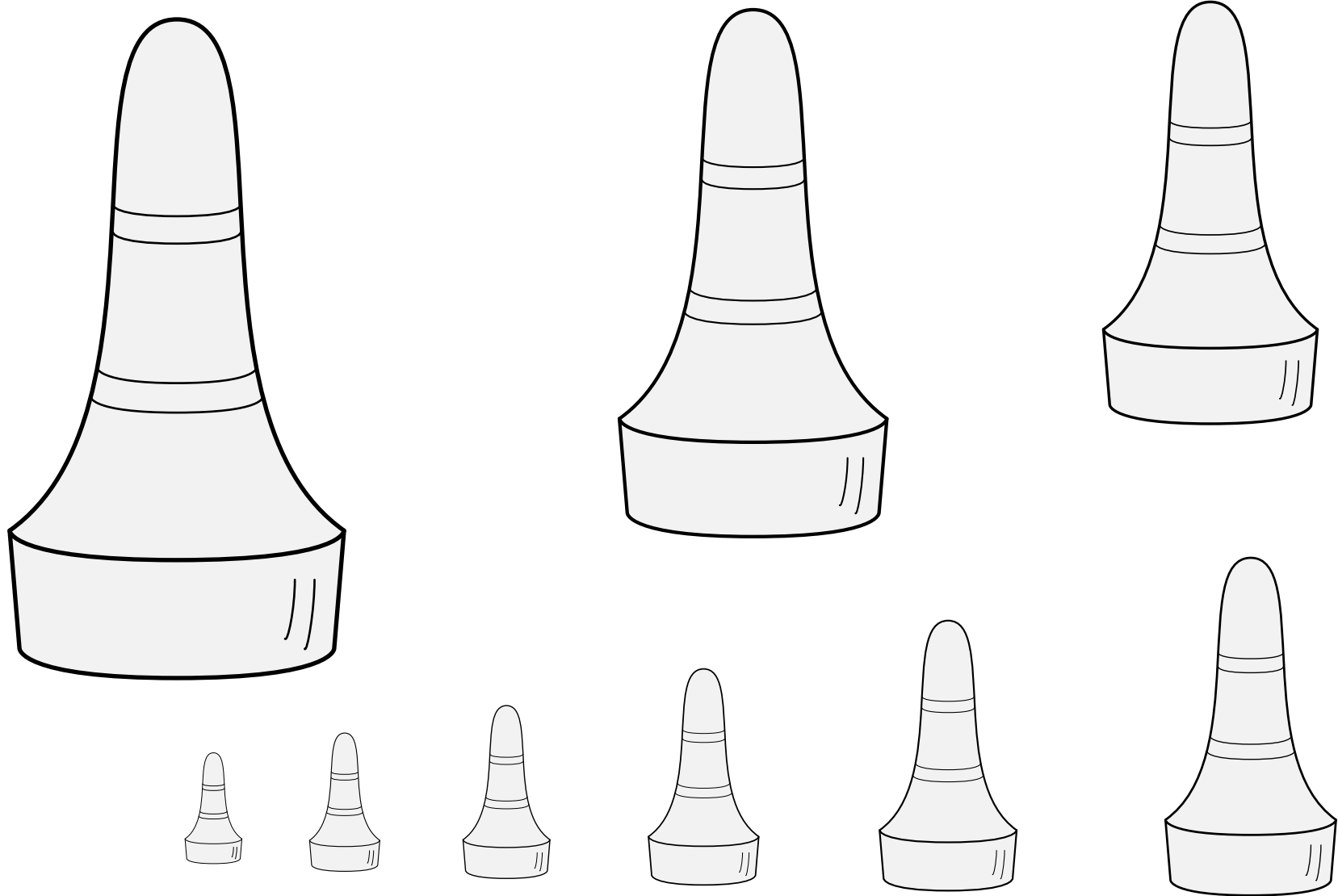

A vertical target used for an outdoor ballgame.

Default orientation: point to chief. No proper coloration.

Source: Stemmario Trivulziano. Artist: Gian Antonio da Tradate.
(Arms of di Bia, page 79.)

Bowling Pin, Lawn (1) 18.46

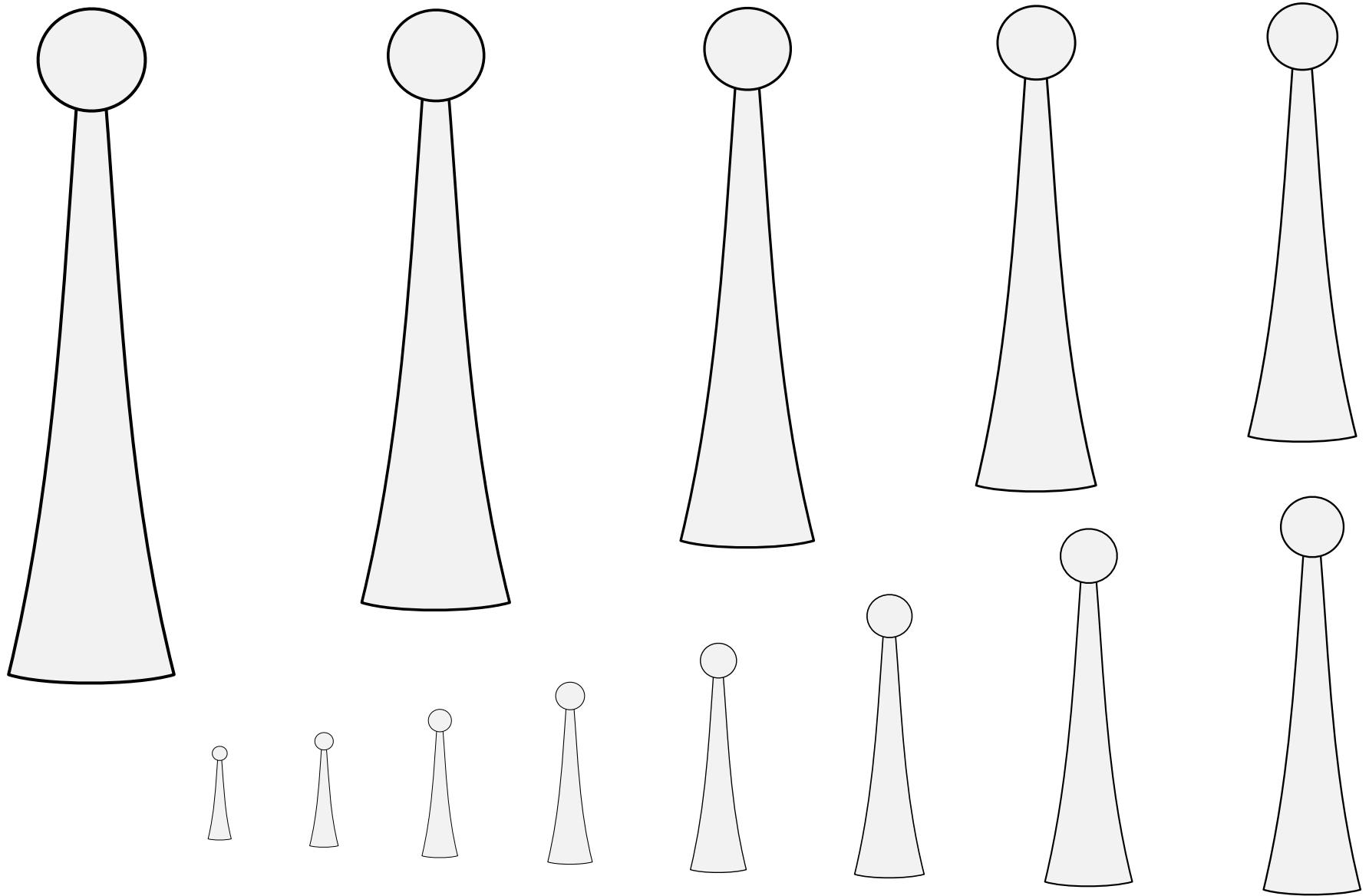

A vertical target used for an outdoor ballgame.

Default orientation: point to chief. No proper coloration.

Source: Siebmacher's Wappenbuch of 1605. Artist: Johann Siebmacher.
(Arms of Die Mutzschefal, page 171.) Adapted by Iago ab Adam.

Bowling Pin, Lawn (2) 18.47

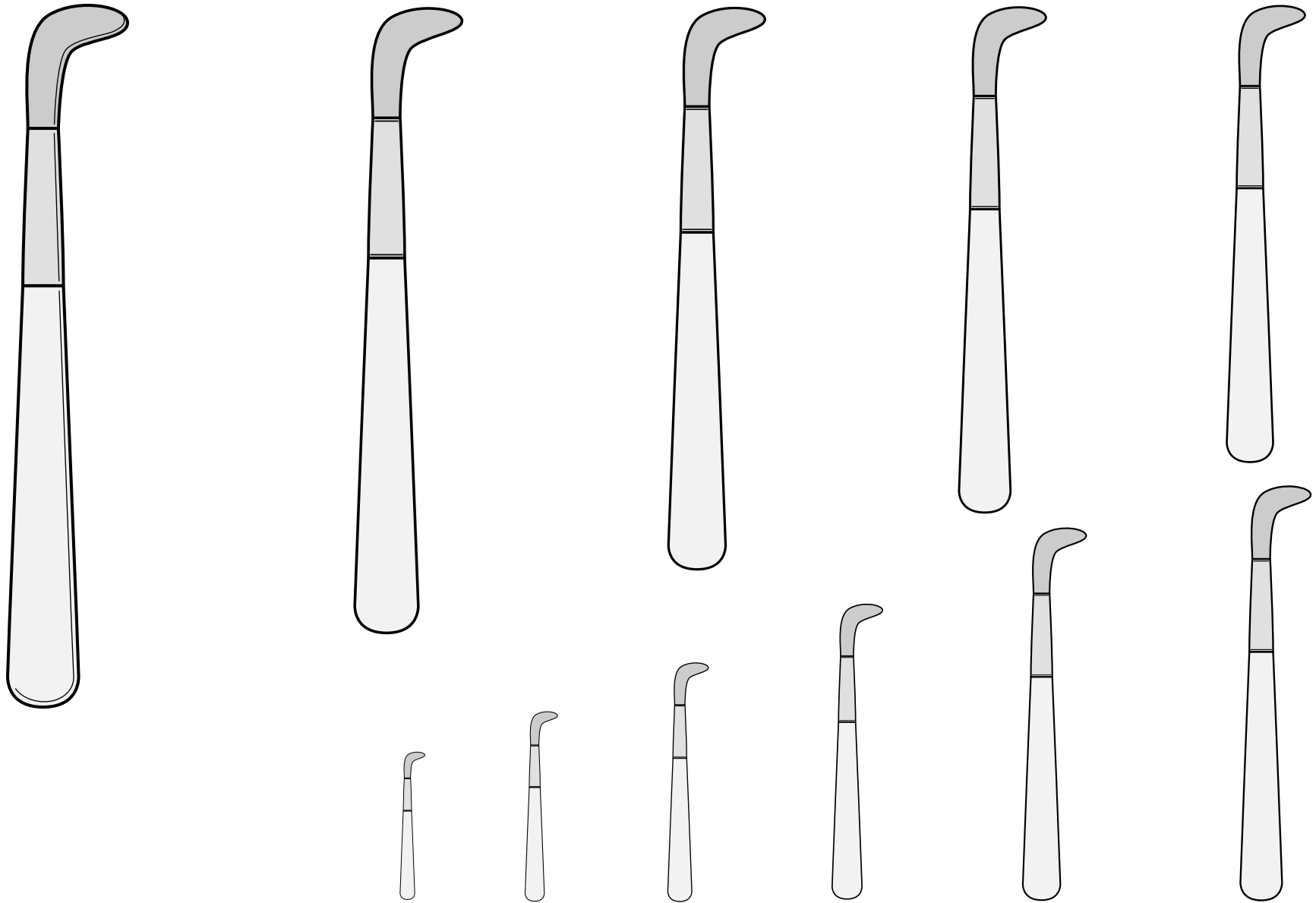

A tool used in gilding, with a paintbrush-style handle attached to a hard and smooth tip made of a tooth or curved stone.

Default orientation: handle to base. No proper coloration.

Burnisher 18.48

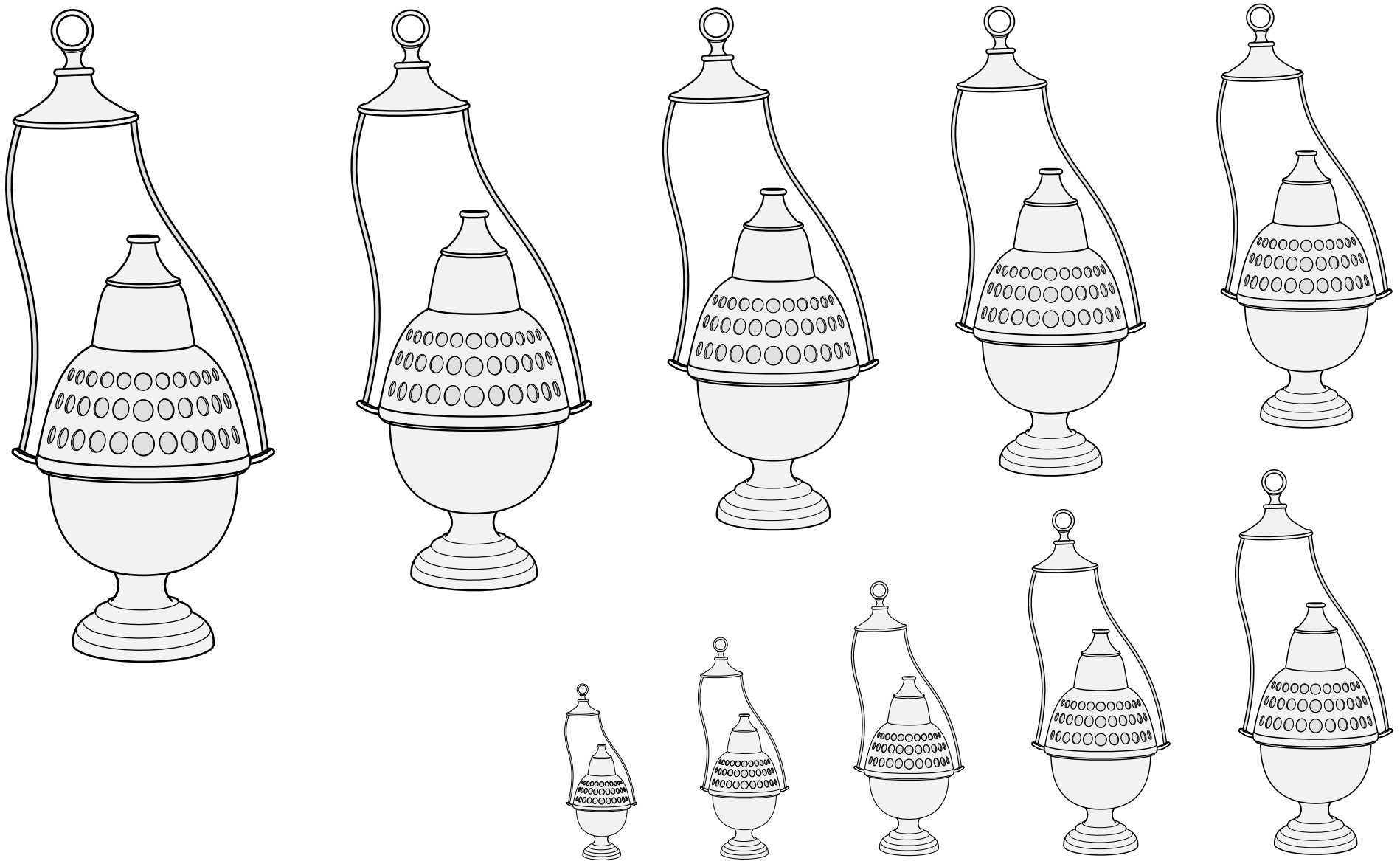

A hanging brazier used to disperse incense.

Default orientation: upright. No proper coloration.

Adapted from photos of a sixteenth-century artifact.
(Met accession number 25.120.554.)

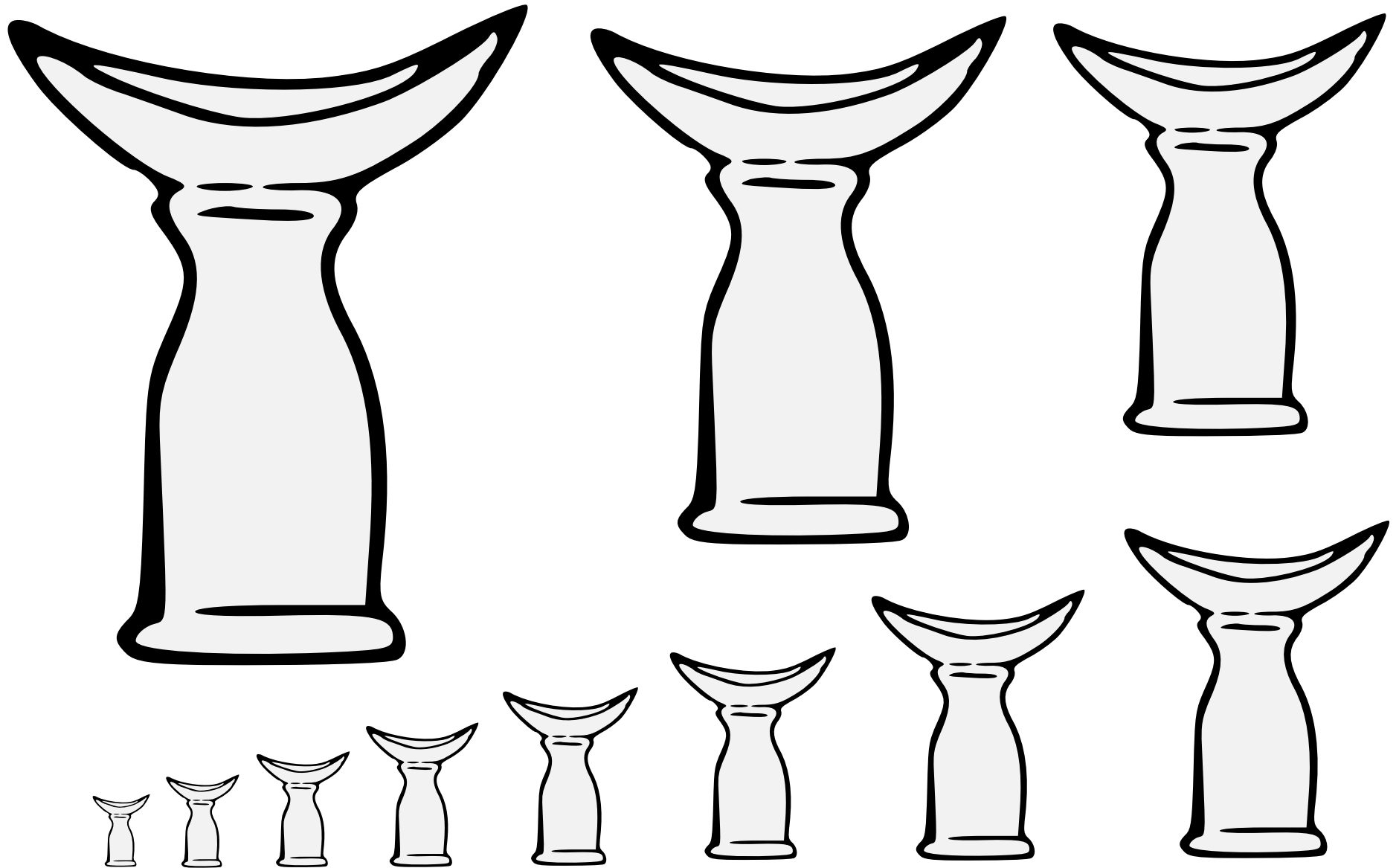

A traditionally-shaped “bishop” piece from a chess set.
Default orientation: palewise. No proper coloration.
Source: Pennsic Traceable Art. Artist unknown.

Chess Bishop 18.50

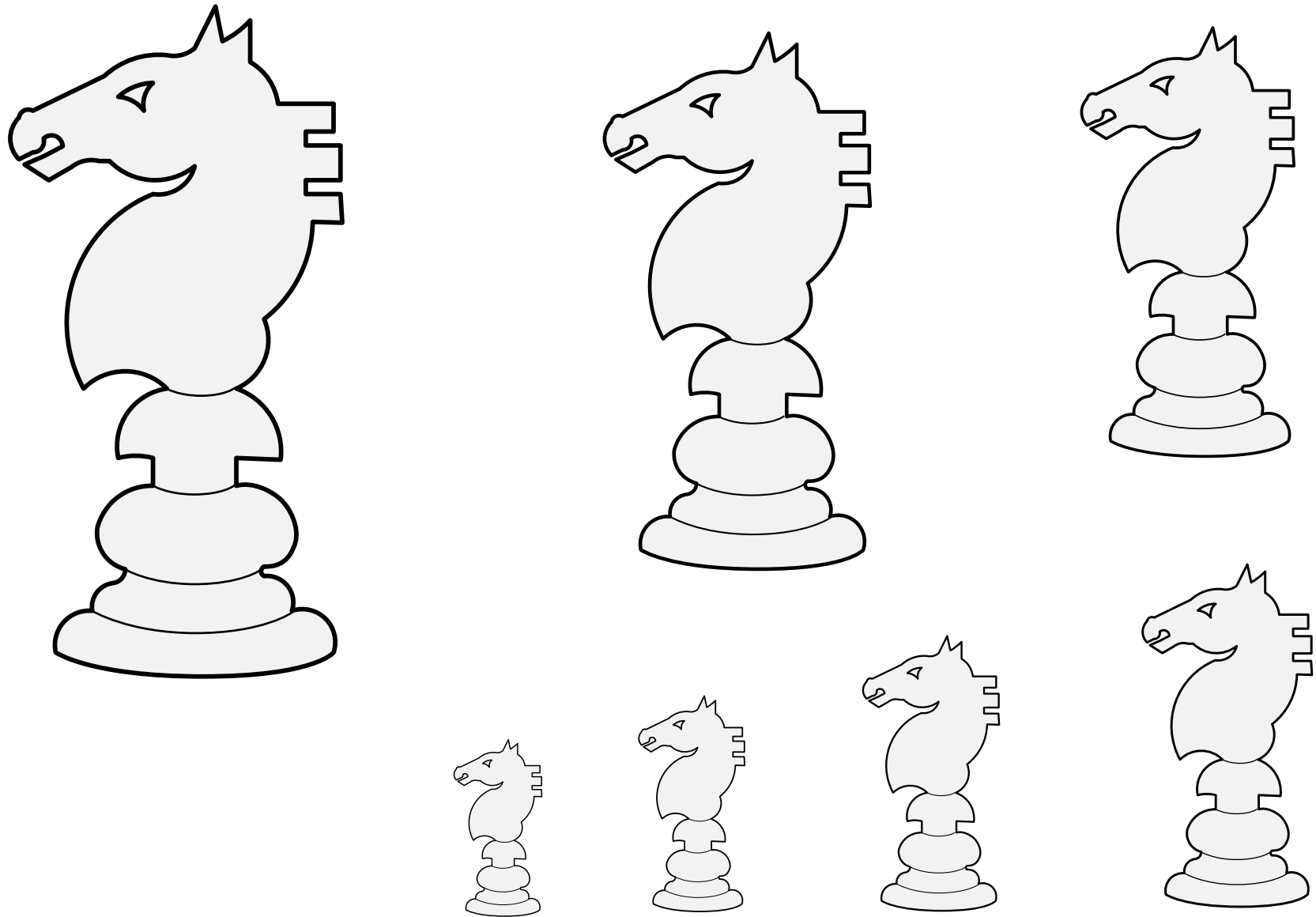

A traditionally-shaped “knight” piece from a chess set. The knight has two heads by default.

Default orientation: palewise, facing dexter. No proper coloration.

Source: Viking Answer Lady SVG Images For Heraldry.

Artist: Gunnvôr silfrahárr.

Chess Knight, One-Headed 18.51

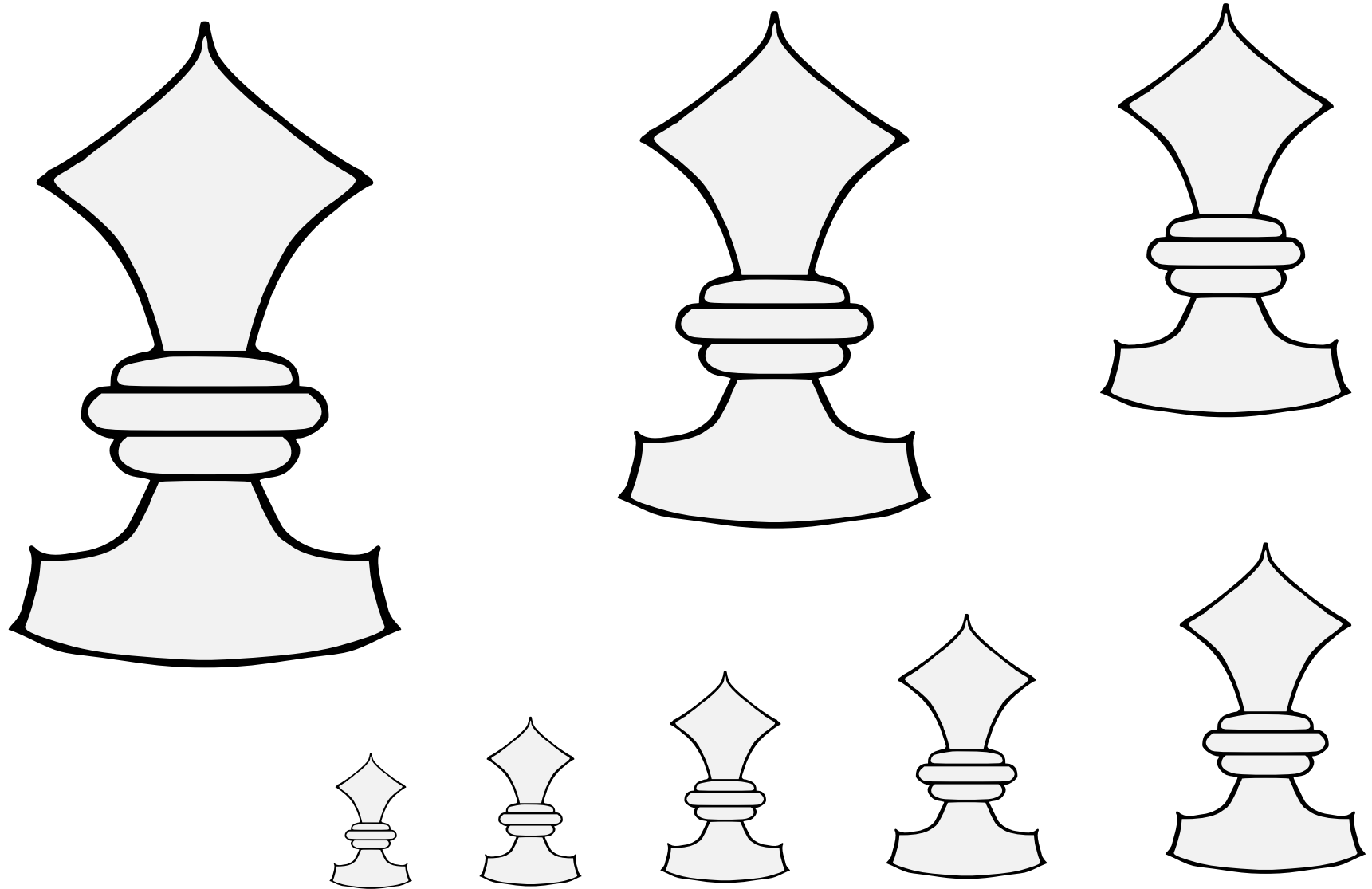

A traditionally-shaped piece from a chess set.

Default orientation: solid end to base. No proper coloration.

Source: Wappenbuch der Arlberg-Bruderschaft. Artist: Vigil Raber.
Adapted by Jessimond of Emerickeskepe.

Chess Piece 18.52

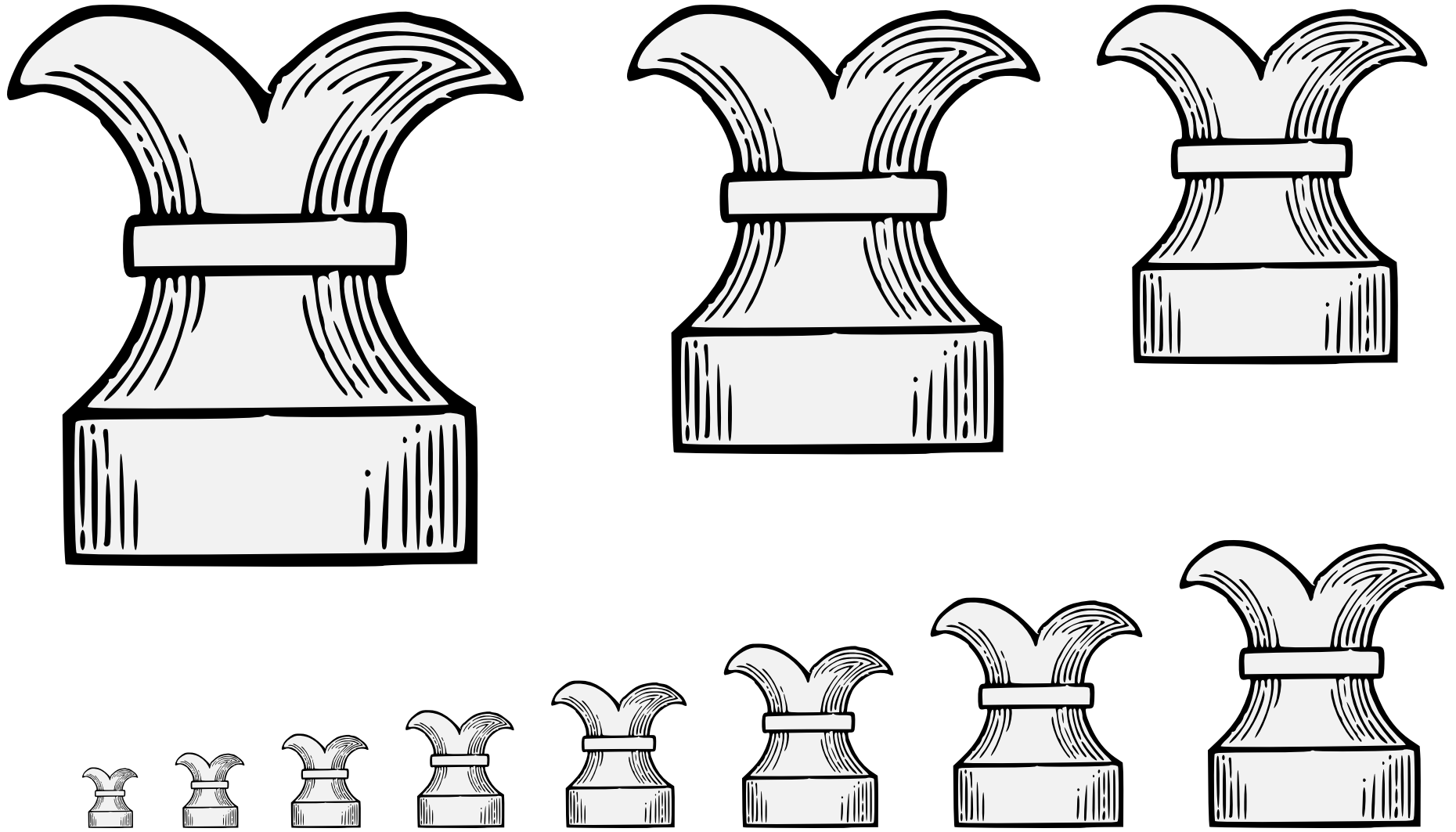

A traditionally-shaped “castle” or “tower” piece from a chess set.
Default orientation: forked end to chief. No proper coloration.
Source: A Complete Guide to Heraldry. Artist: Graham Johnston.

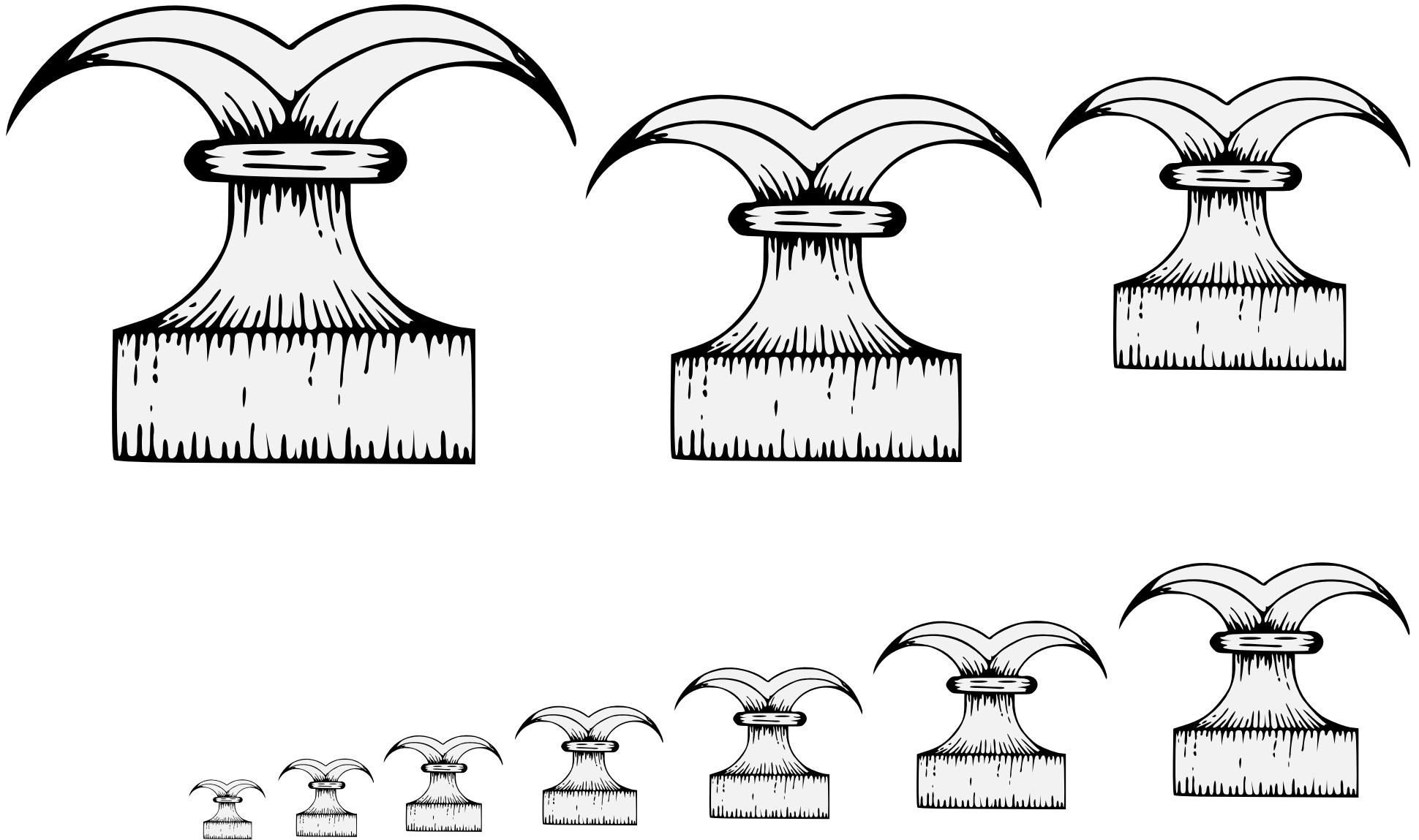

A traditionally-shaped “castle” or “tower” piece from a chess set.

Default orientation: forked end to chief. No proper coloration.

Source: Heraldic Templates. Artist: Torric inn Björn.

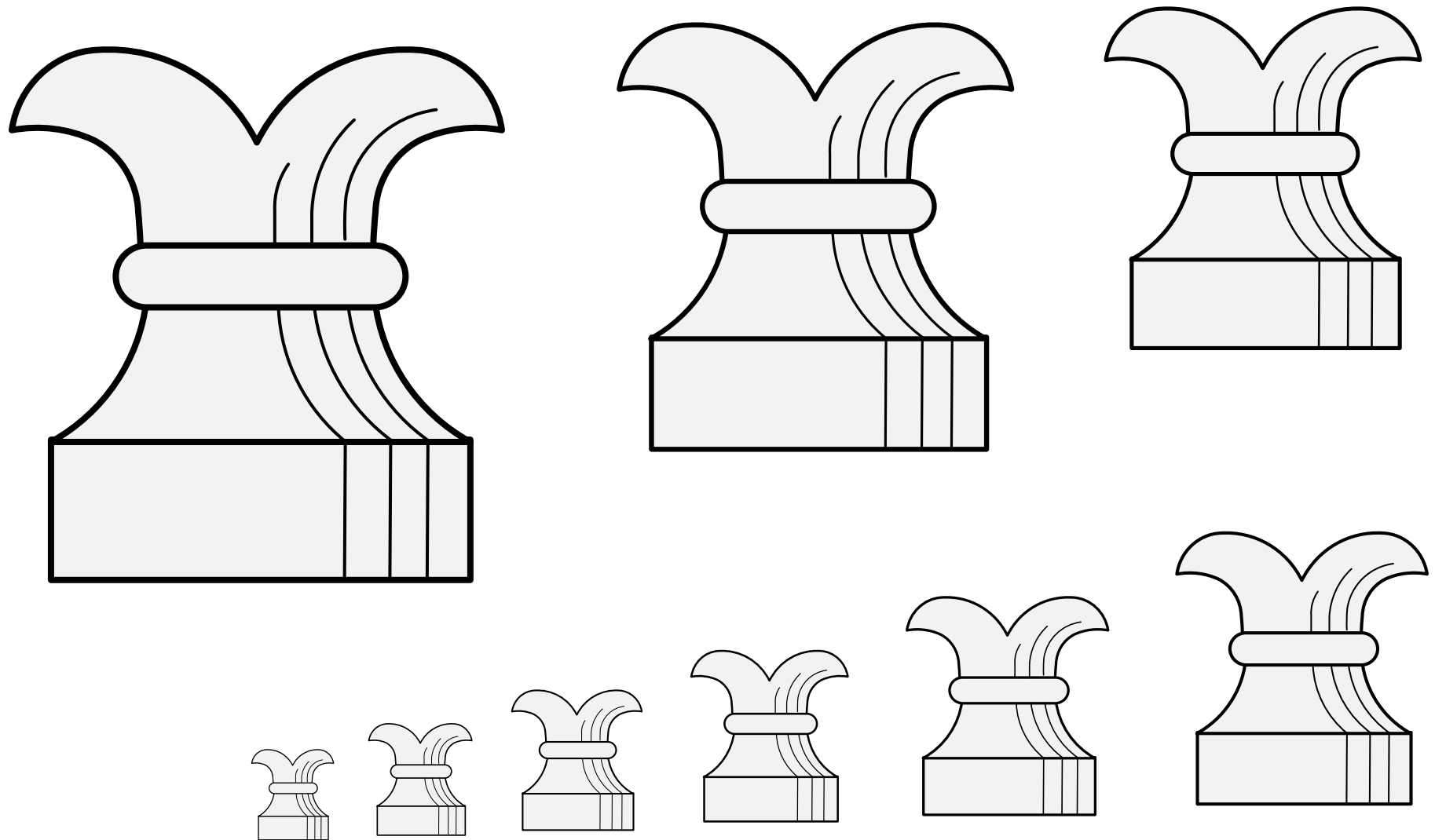

A traditionally-shaped “castle” or “tower” piece from a chess set.

Default orientation: forked end to chief. No proper coloration.

Source: Viking Answer Lady SVG Images For Heraldry. Artist: Gunnvôr silfráhr.

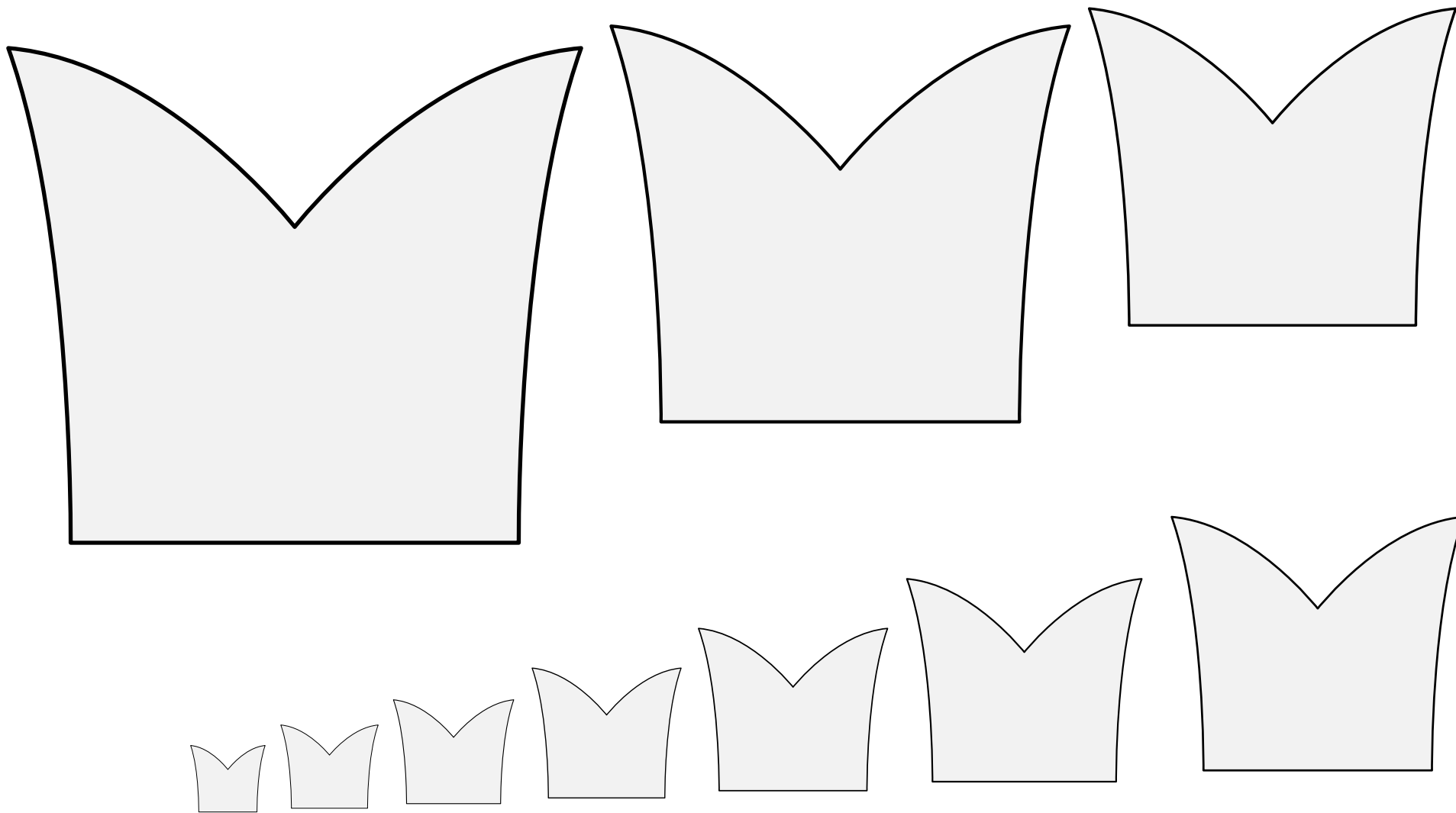

A traditionally-shaped “castle” or “tower” piece from a chess set.

Default orientation: forked end to chief. No proper coloration.

Source: Livro do Armeiro-Mor. Artist: Jean Du Cros.
(Arms of Marroco, folio 22v.)

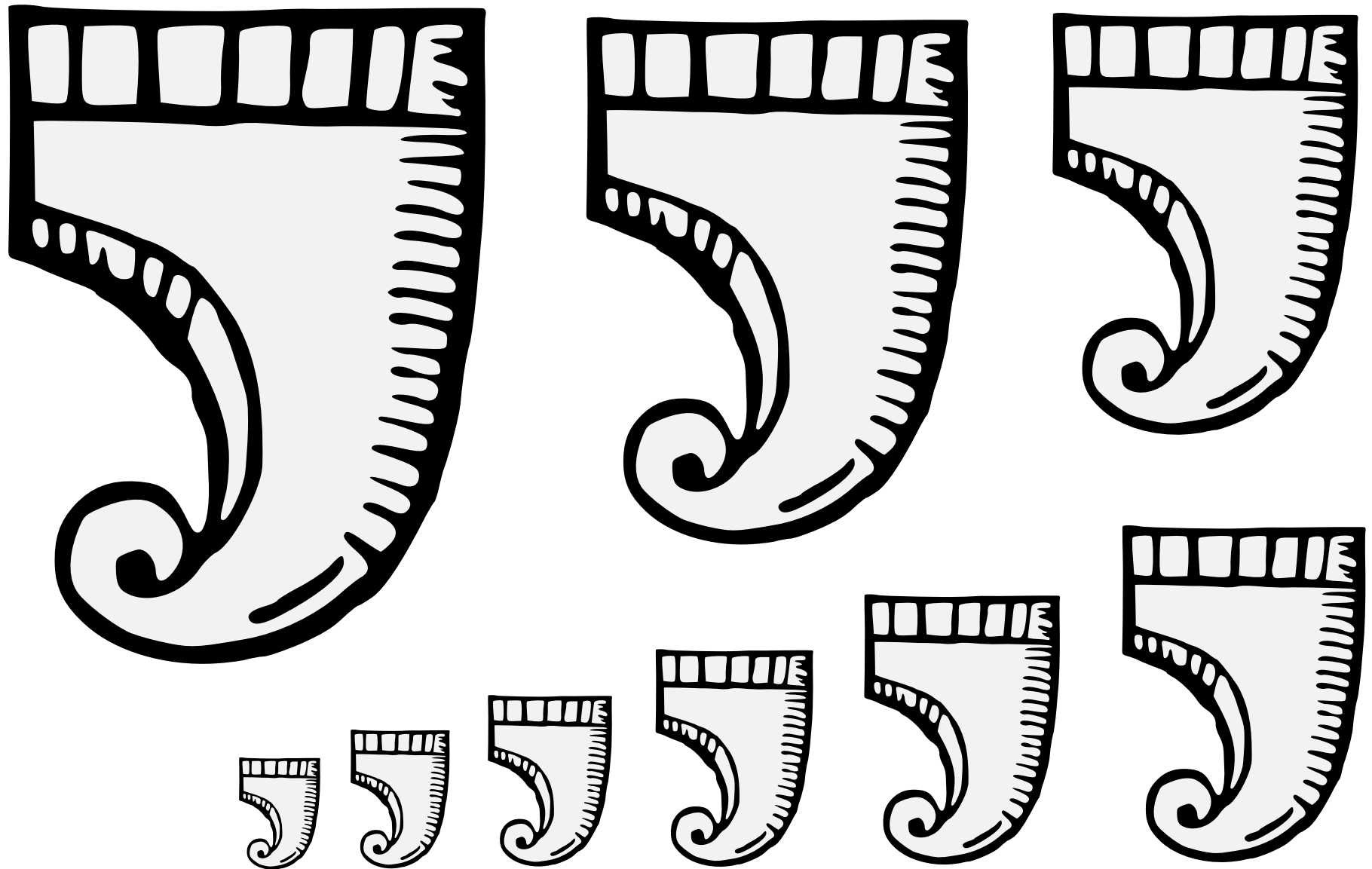

A very stylized depiction of a musical instrument, perhaps related to panpipes.

Default orientation: curlicue to dexter base. No proper coloration.

Source: Guillim's Display of Heraldry. Artist unknown.

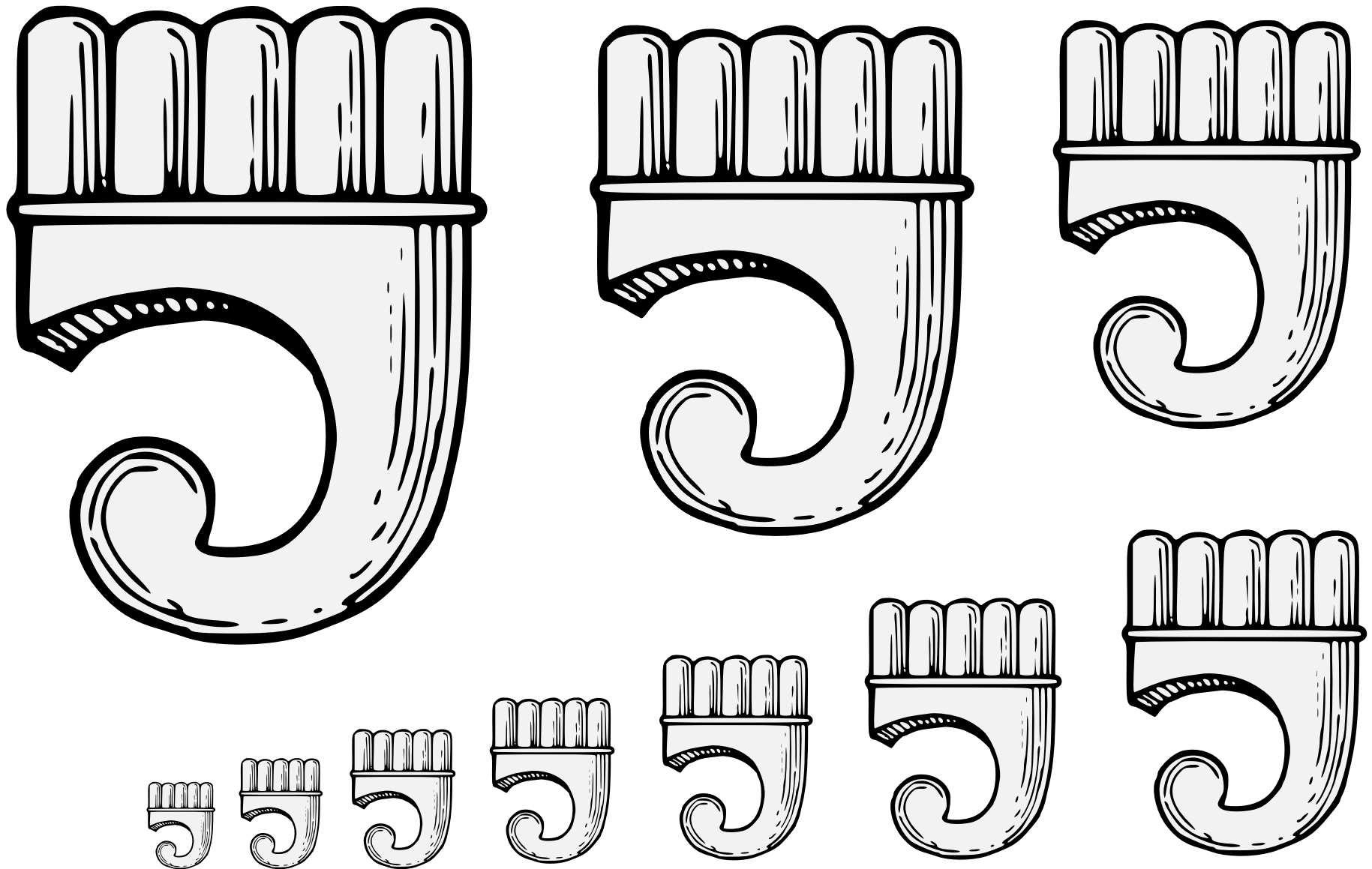

A very stylized depiction of a musical instrument, perhaps related to panpipes.

Default orientation: curlicue to dexter base. No proper coloration.

Source: A Complete Guide to Heraldry. Artist: Graham Johnston.

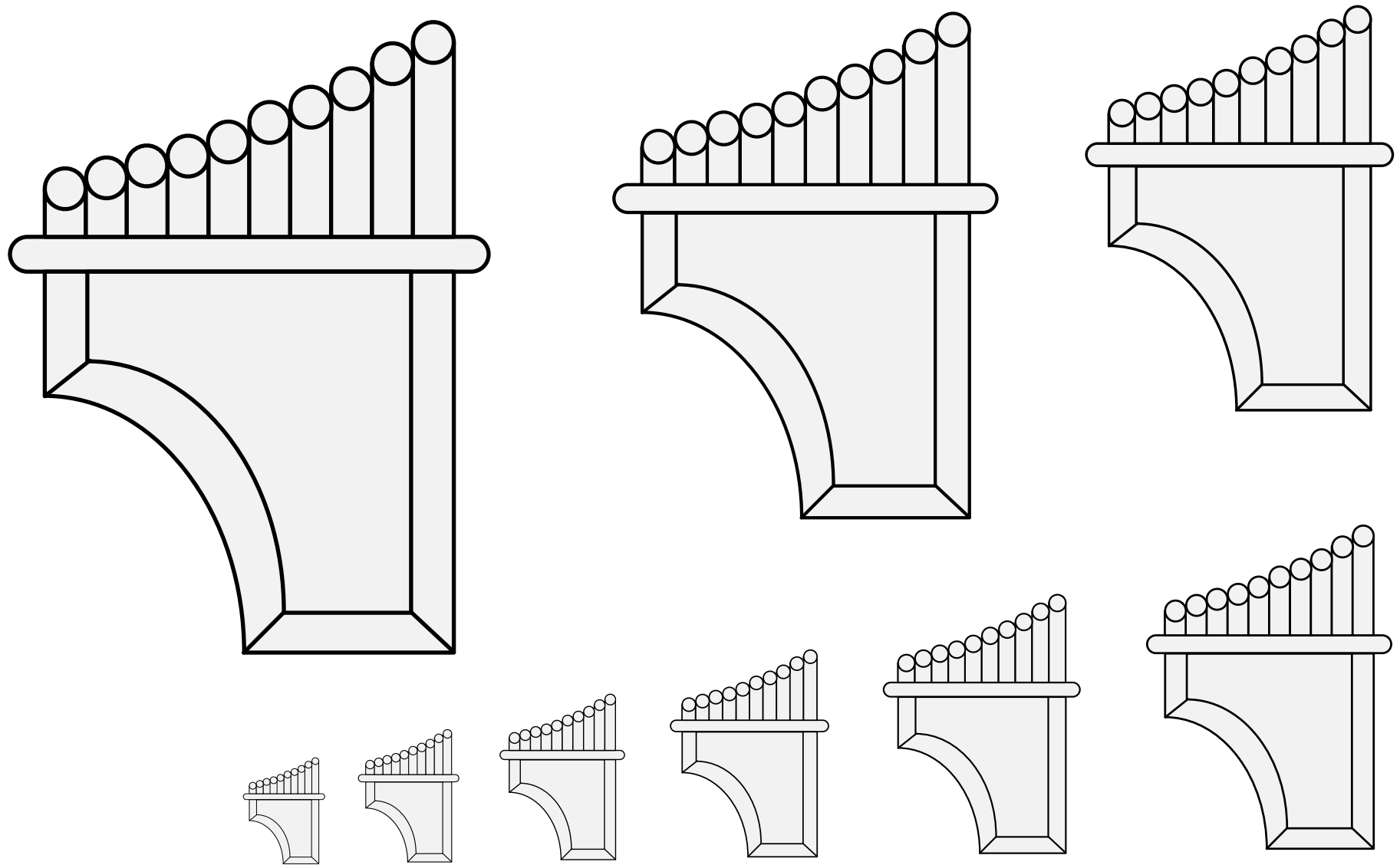

A very stylized depiction of a musical instrument, perhaps related to panpipes.

Default orientation: curlicue to dexter base. No proper coloration.

Source: Two Tudor Books of Arms. Artist: Robert Cooke. (Page 54.)

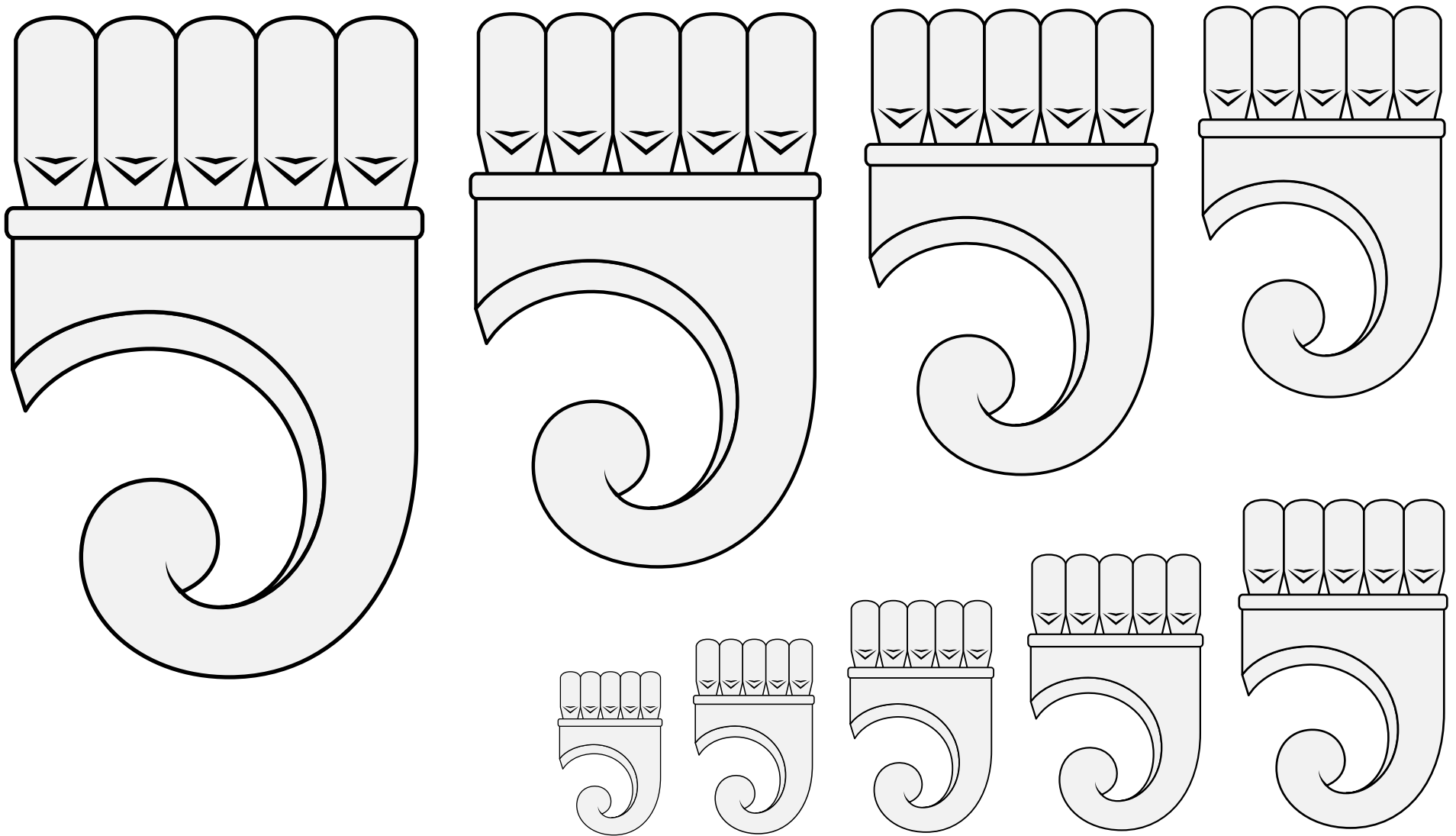

A very stylized depiction of a musical instrument, perhaps related to panpipes.

Default orientation: curlicue to dexter base. No proper coloration.

Source: WappenWiki. Artist: Joakim Spuller.

Clarion (4) 18.60

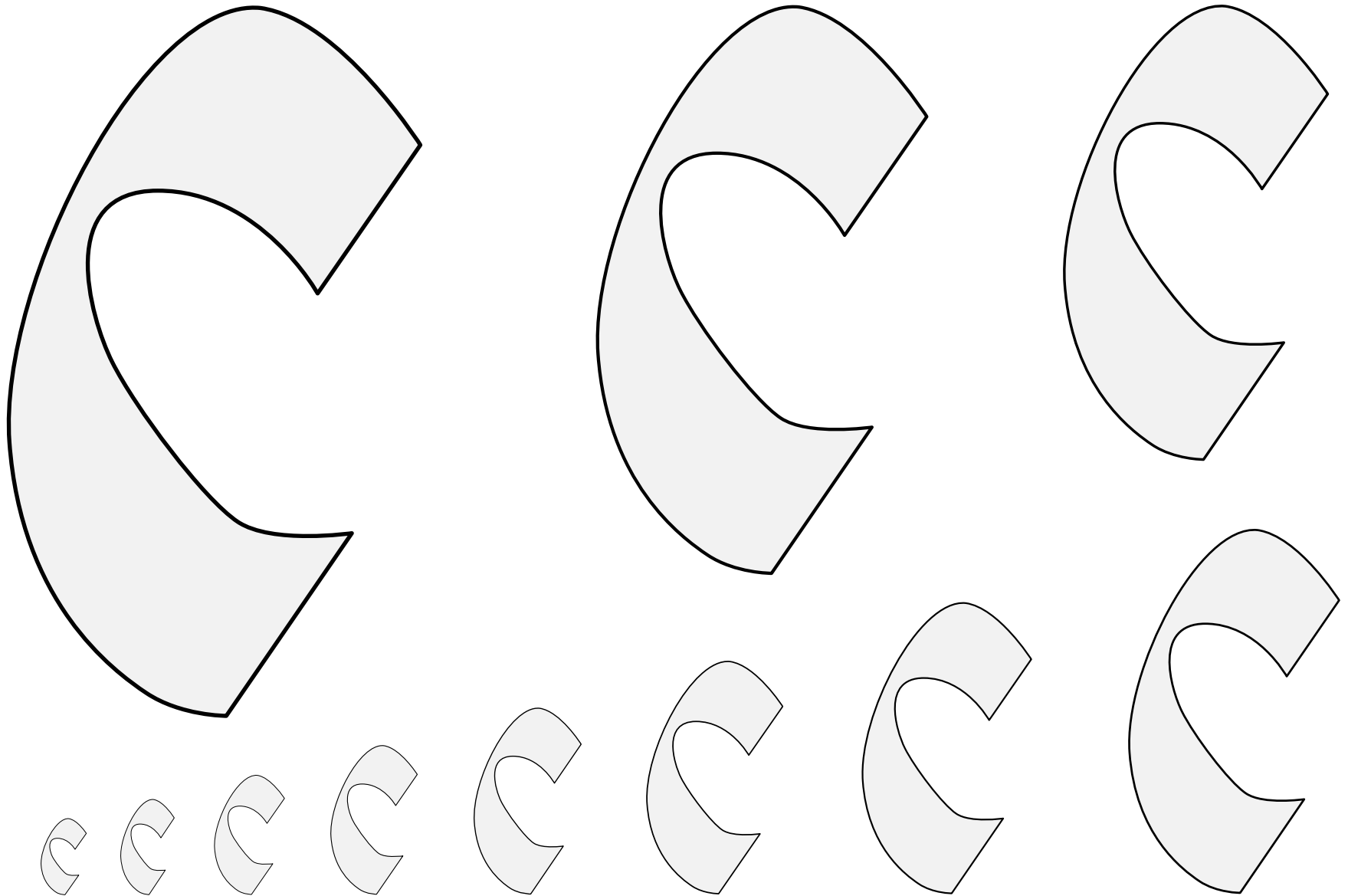

A marker placed on the staff of printed music to indicate the position of the notes.

The C clef typically is shown as a stylized letter C.

Adapted from an image of British Museum MS Add. 30091. (Circa 1275.)

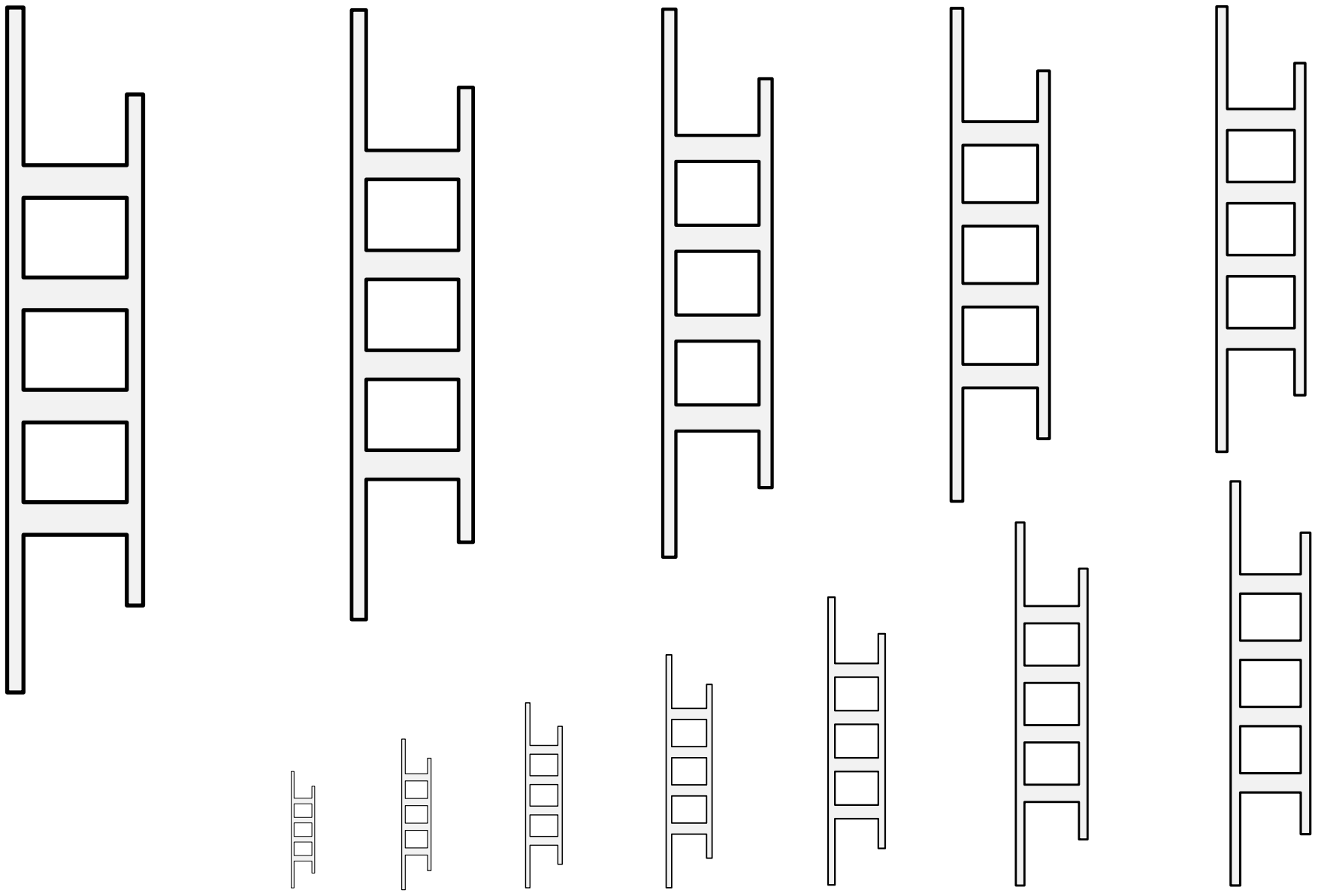

A marker placed on the staff of printed music to indicate the position of the notes.
This form was used to represent C clef in mensural notation used in the 15th century.

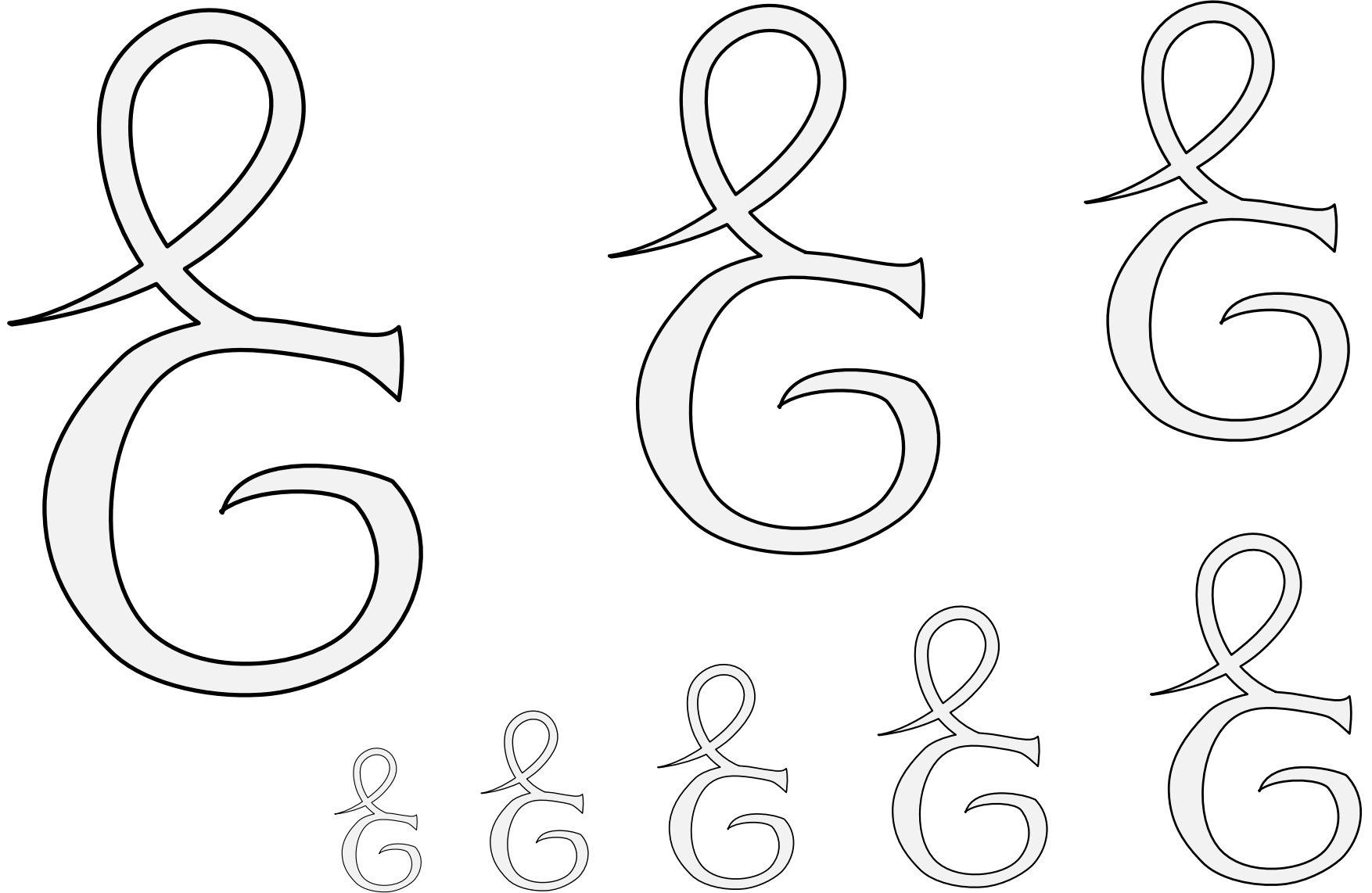

A marker placed on the staff of printed music to indicate the position of the notes.
The G clef typically is shown as a stylized letter G with a swirl attached above it.
Adapted from images of sixteenth-century French musical notation.

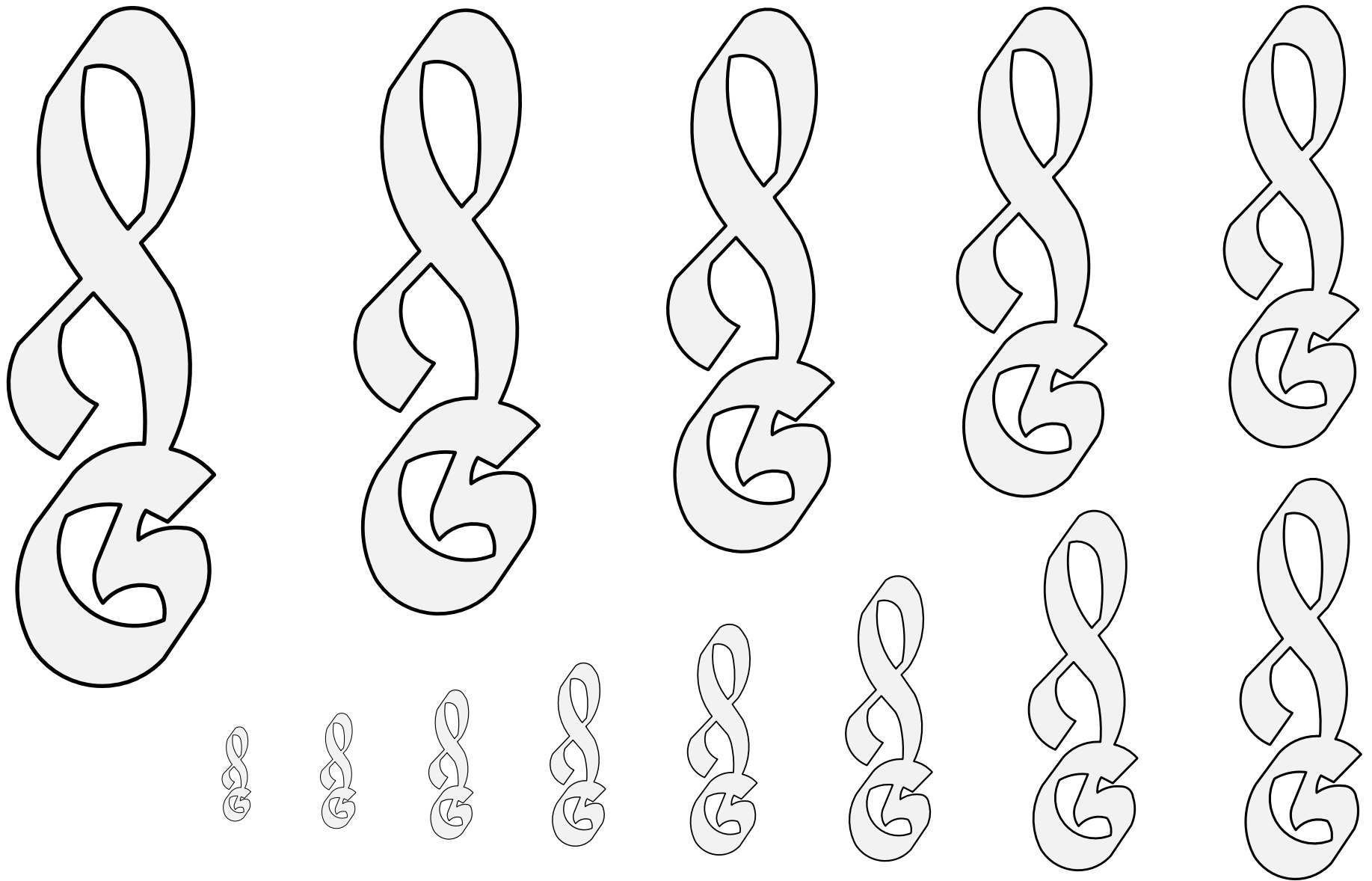

A marker placed on the staff of printed music to indicate the position of the notes.

The G clef typically is shown as a stylized letter G with a swirl attached above it.

Adapted from images of sixteenth-century French musical notation.

Artist: Gunnvör silfrahárr.

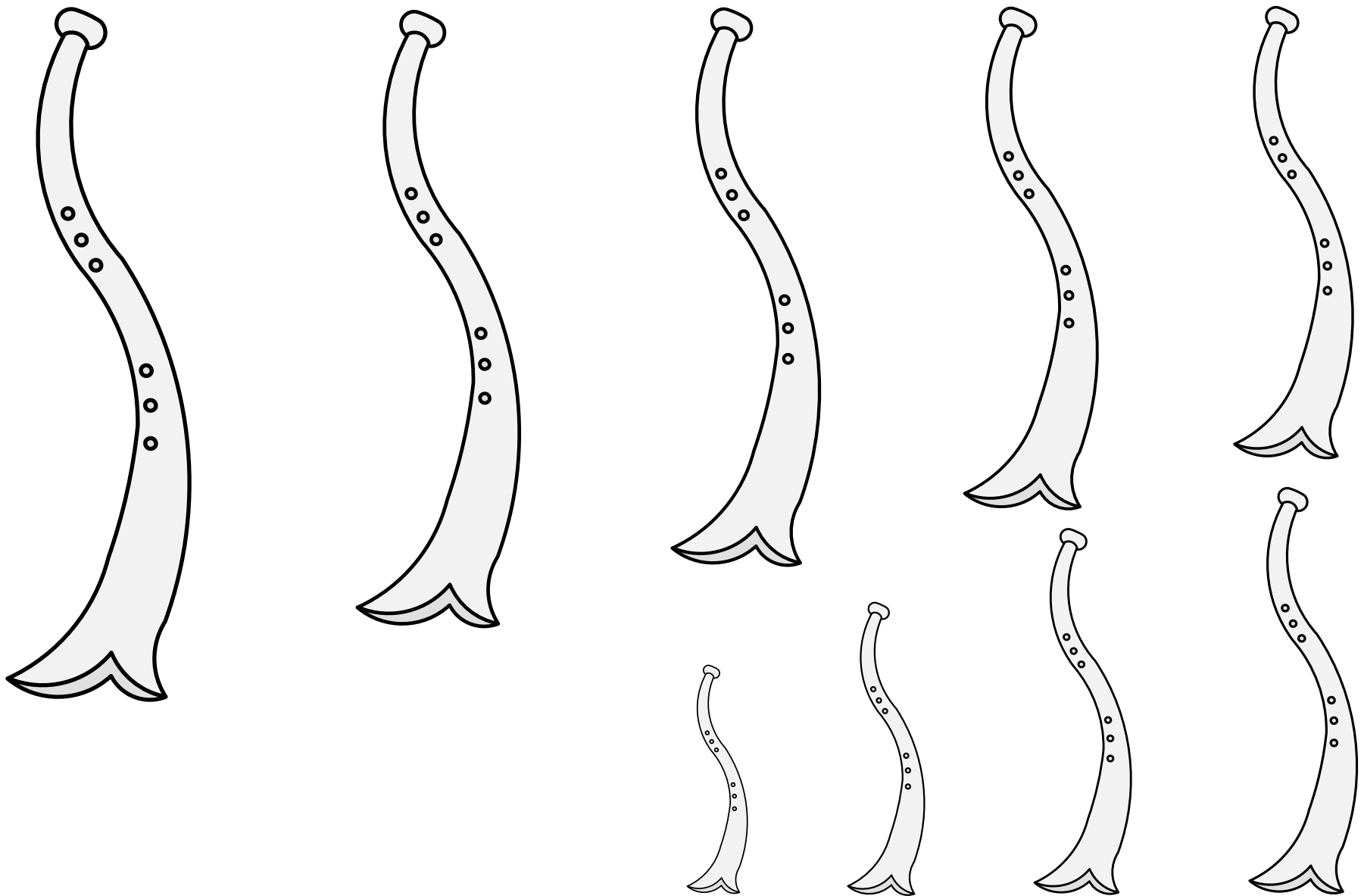

A common woodwind instrument of the Renaissance, also called the “lyzard” because of its shape.

Default alignment: mouthpiece to chief. No proper coloration.

Source: Viking Answer Lady SVG Images For Heraldists. Artist: Gunnvôr silfrárr.

Cornetto, Tenor 18.65

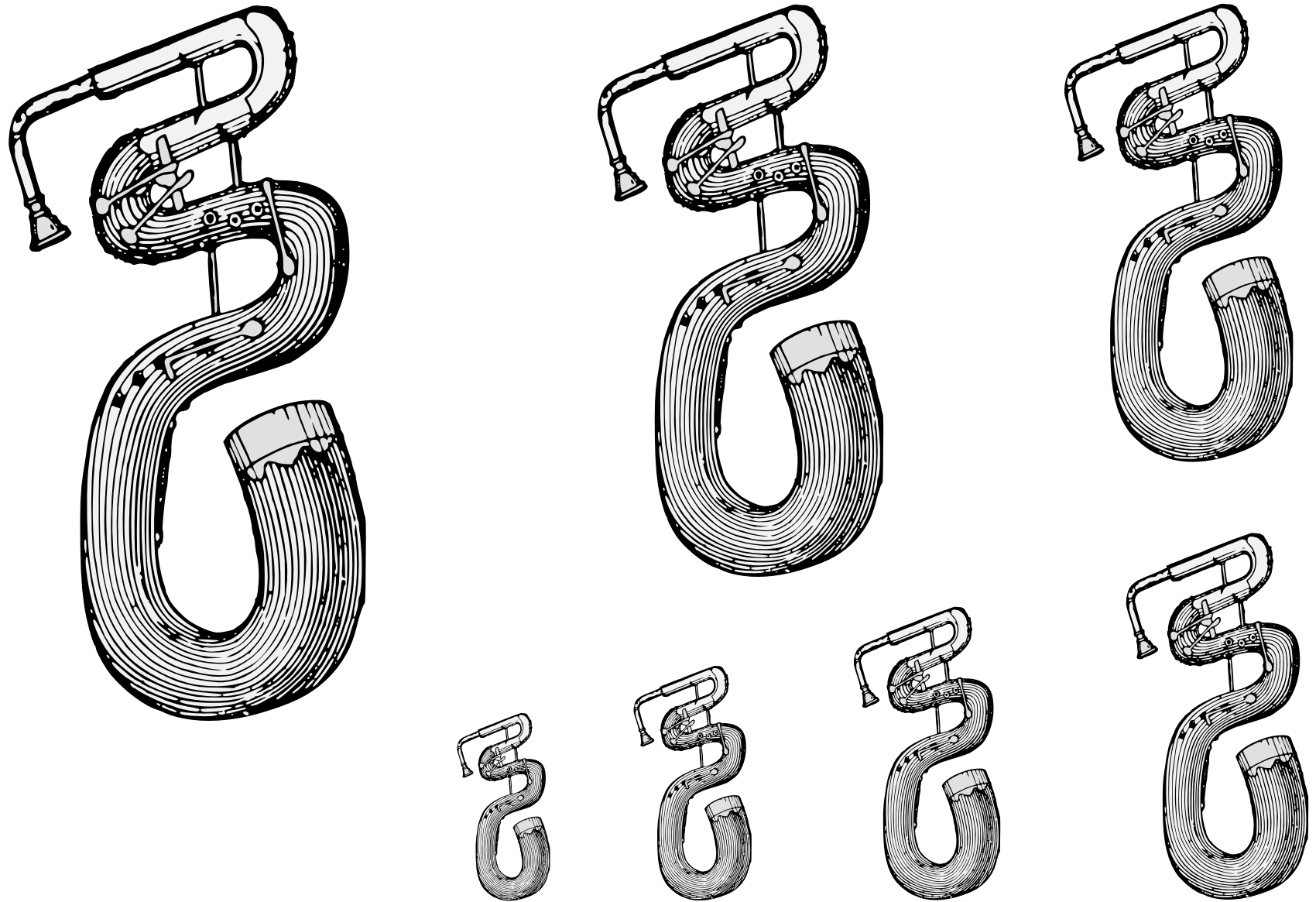

A common woodwind instrument of the Renaissance, also called the “serpent” because of its shape.

Default alignment: mouthpiece to chief. No proper coloration.

Source: Nelson's Perpetual Loose-Leaf Encyclopedia. Artist unknown.

Cornetto, Bass 18.66

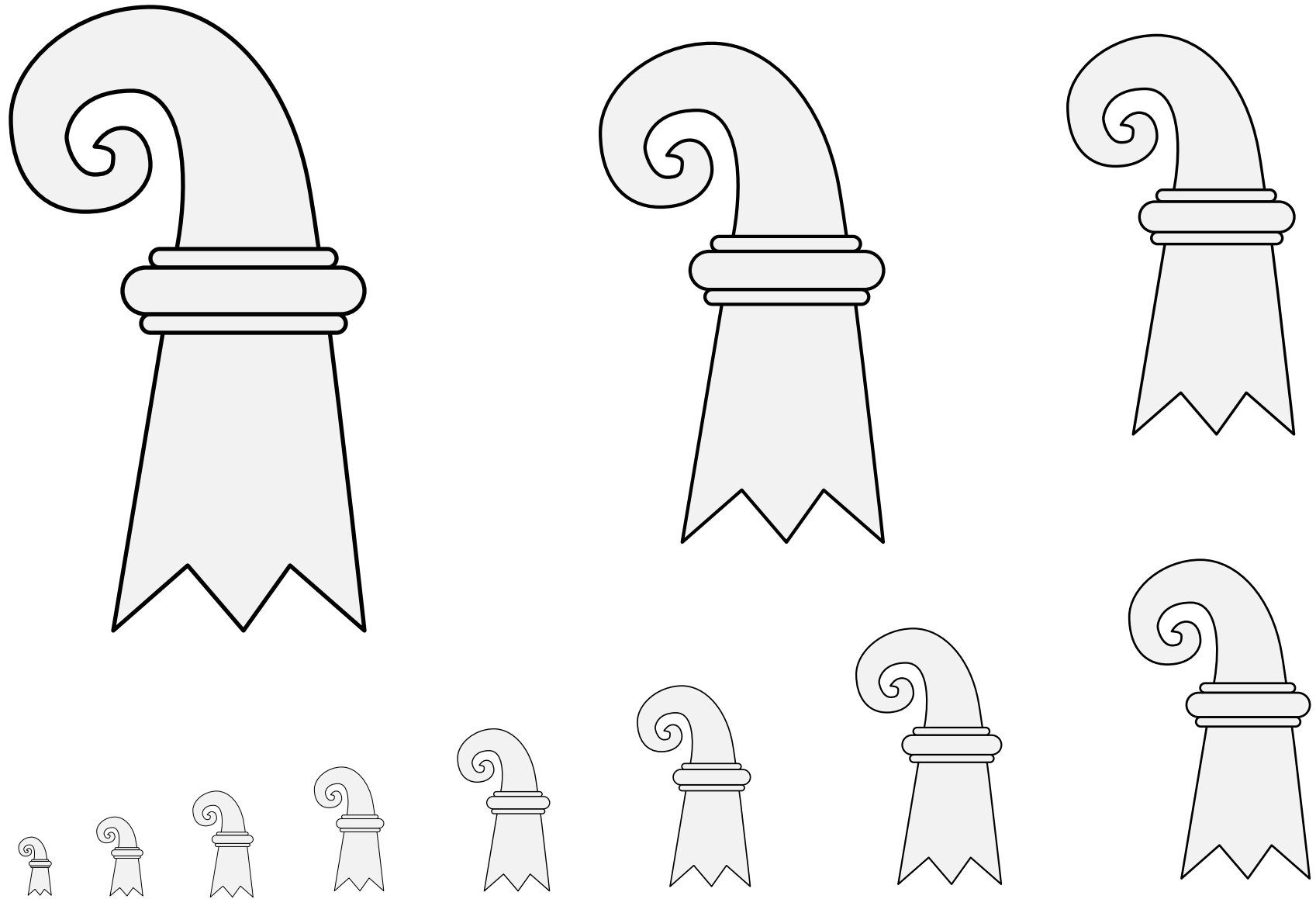

A very stylized crozier used in the arms of Basel.
Default orientation: curl to chief and dexter. No proper coloration.
Adapted from images of the civic insignia of Basel.

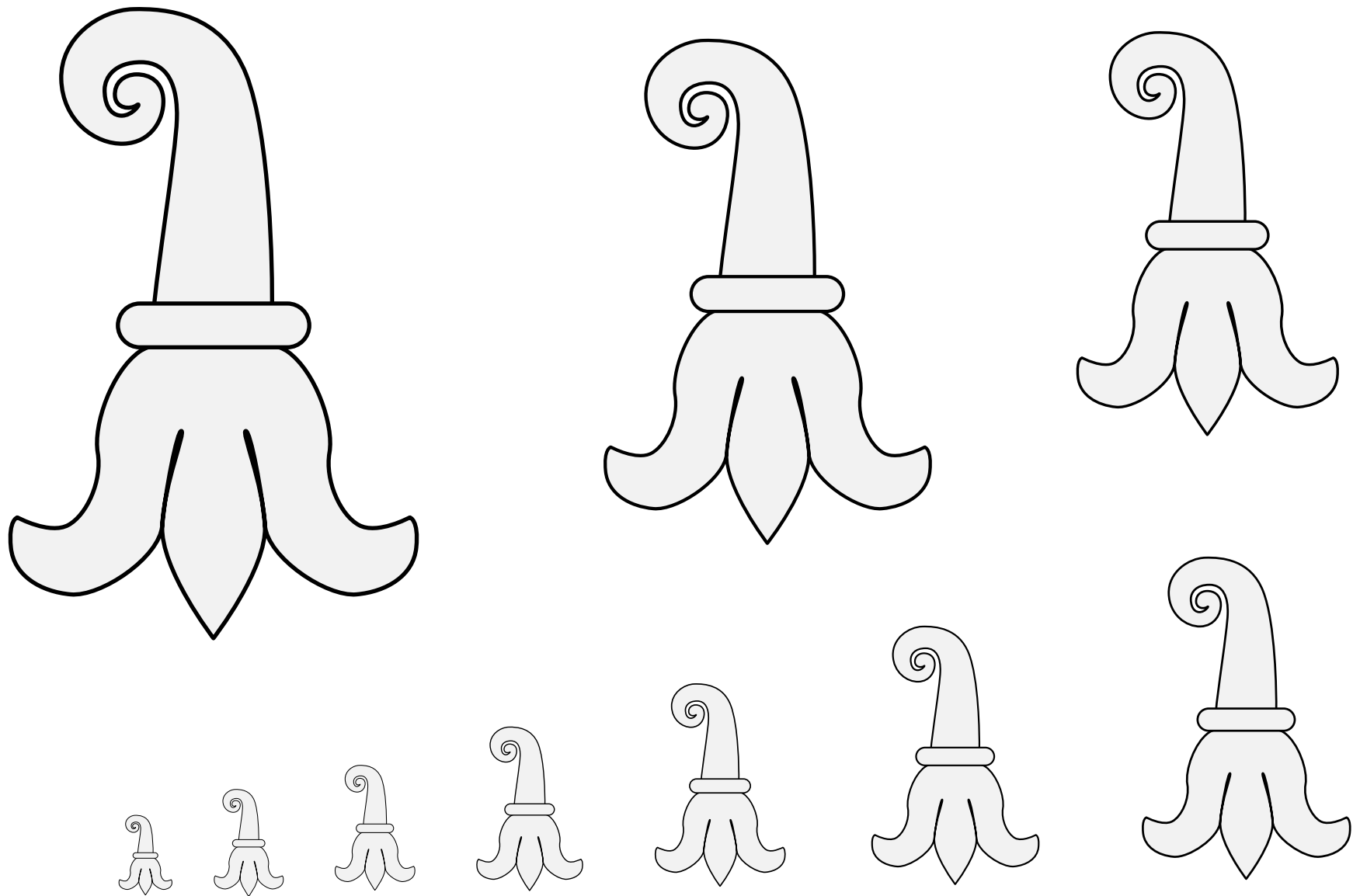

A very stylized crozier used in the arms of Basel.
Default orientation: curl to chief and dexter. No proper coloration.
Adapted from images of the civic insignia of Basel.

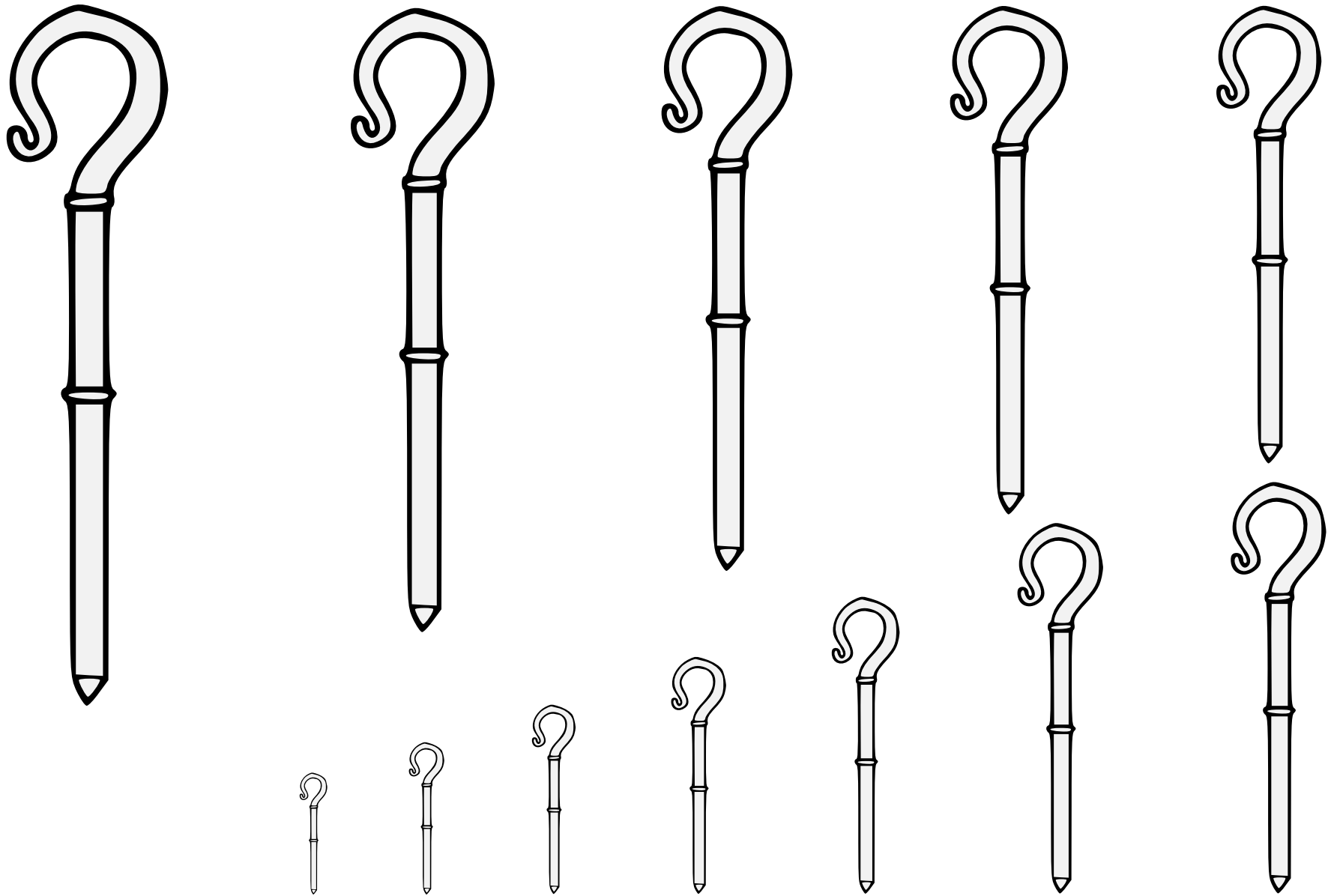

A staff with a bent end. The crozier is a fancier version of a shepherd's crook, used by bishops.

Default orientation: palewise, handle to dexter chief. No proper coloration.

Source: Pennsic Traceable Art. Artist unknown.

Crozier (1) 18.69

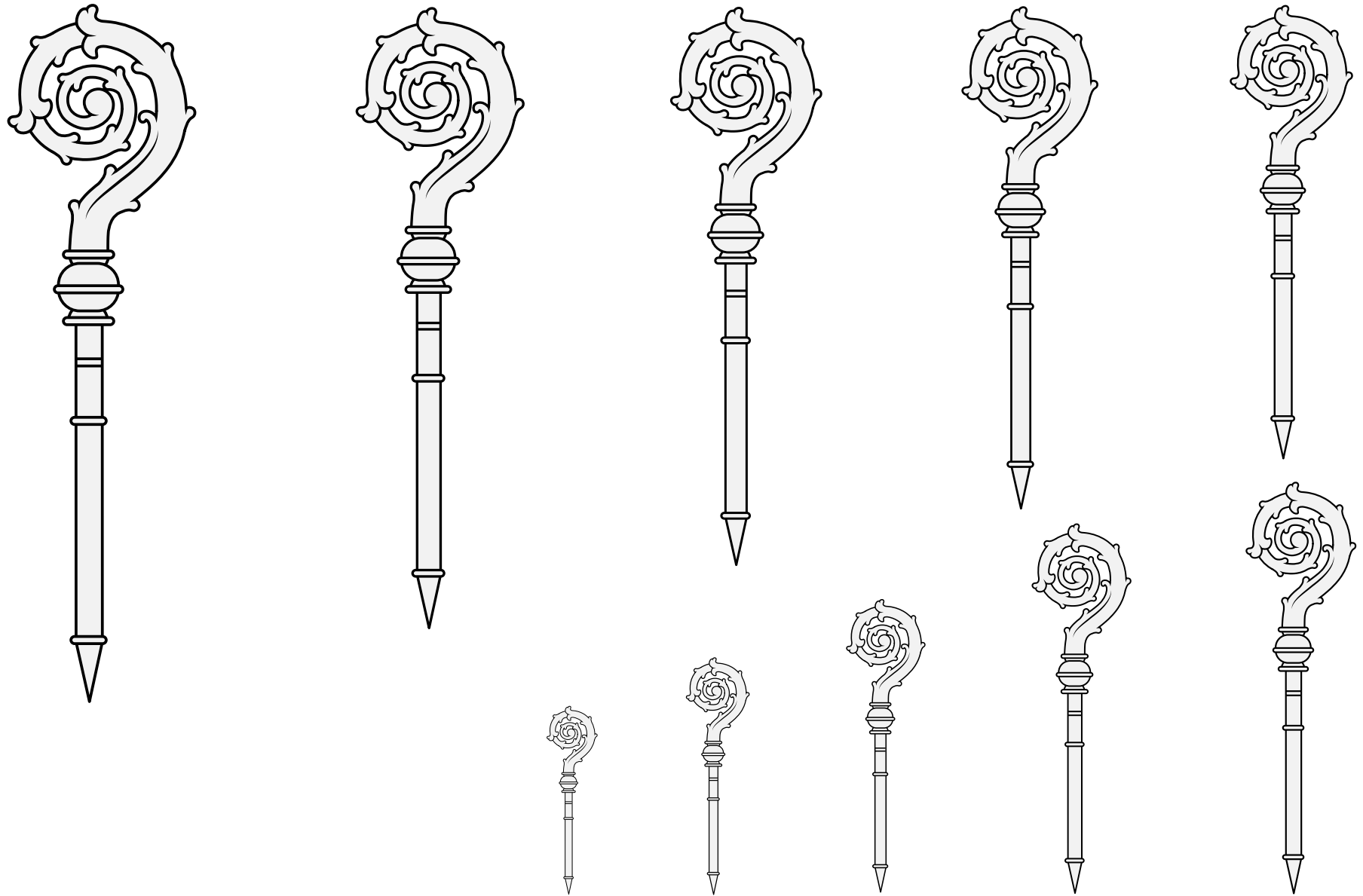

A staff with a bent end. The crozier is a fancier version of a shepherd's crook, used by bishops.

Default orientation: palewise, handle to dexter chief. No proper coloration.

Source: WappenWiki. Artist: Joakim Spuller.

Crozier (2) 18.70



A staff with a bent end. The crozier is a fancier version of a shepherd's crook, used by bishops.

Default orientation: palewise, handle to dexter chief. No proper coloration.

Source: Banderia Prutenorum. (Folio 6v.) Artist unknown.

Adapted by Wahrija of St Christina the Astonishing.

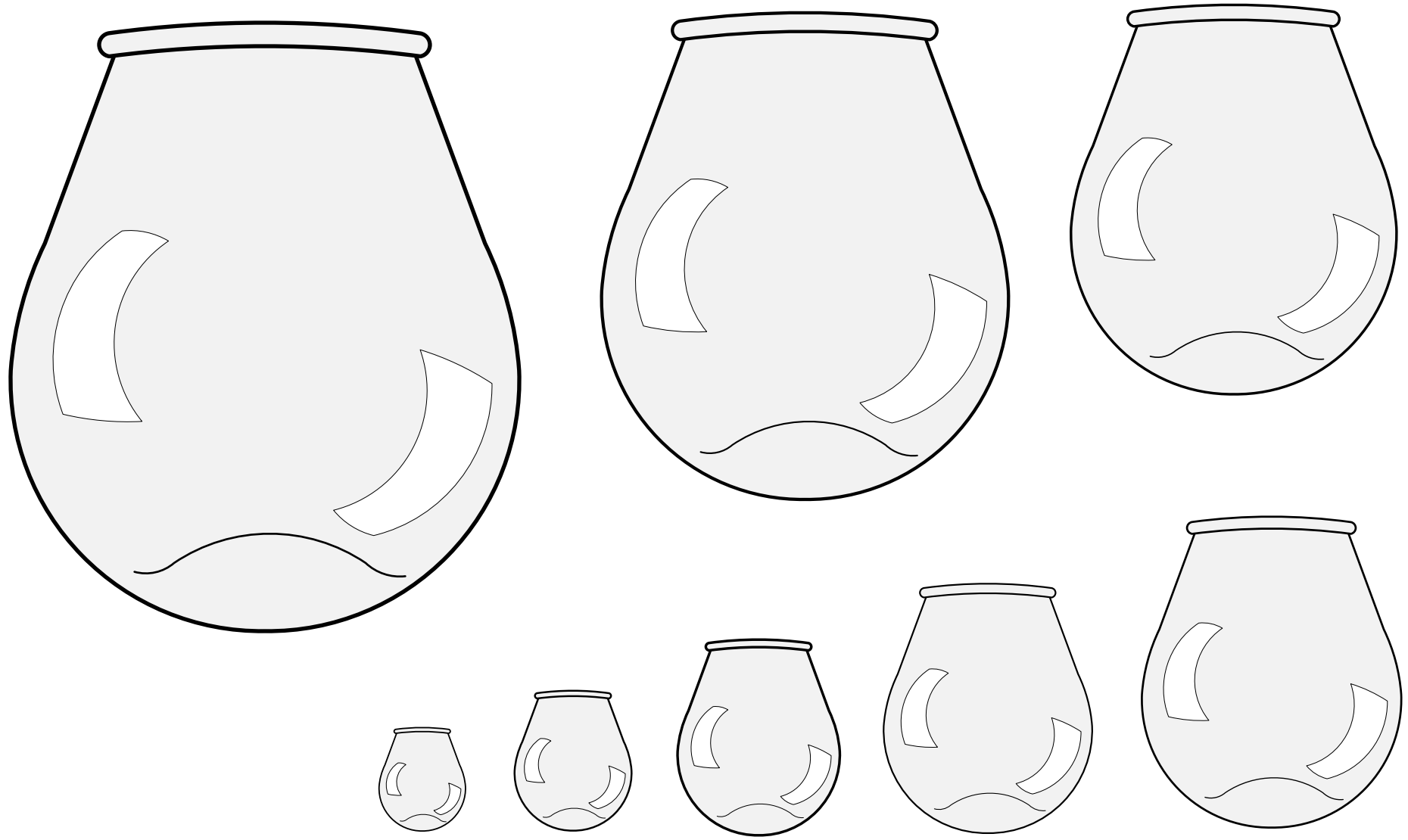

A round-bottomed glass vessel as might be used for cupping, an ancient medical treatment.

Default orientation: opening to chief. No proper coloration.

Source: Viking Answer Lady SVG Images For Heraldists. Artist: Gunnvôr silfráhr.

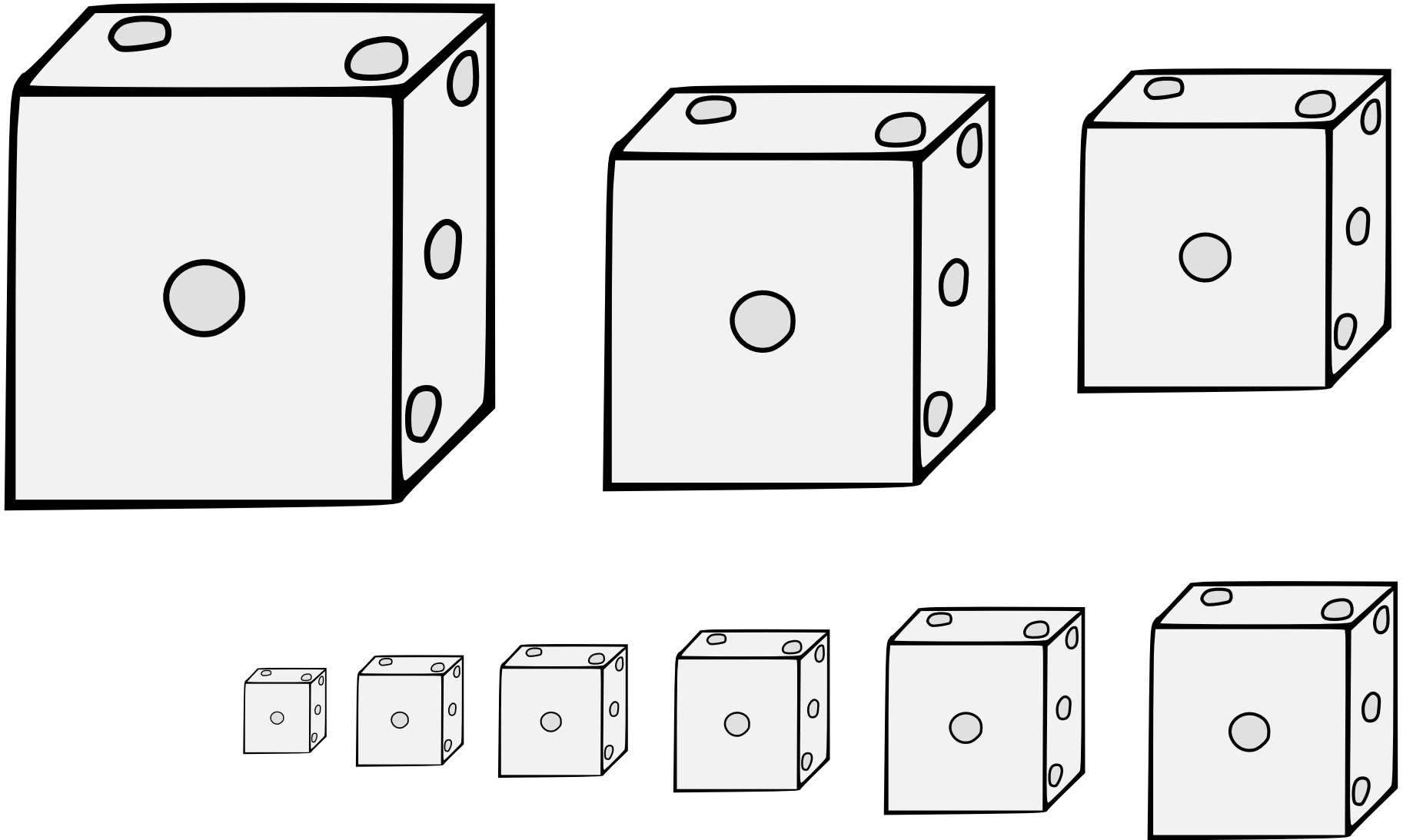

A generator of random outcomes.

Default orientation: affronty, often in trian aspect. No proper coloration.

Blazoned "a die *tincture* marked (or spotted) *tincture*."

Source: Pennsic Traceable Art. Artist unknown.

Die (1) 18.73

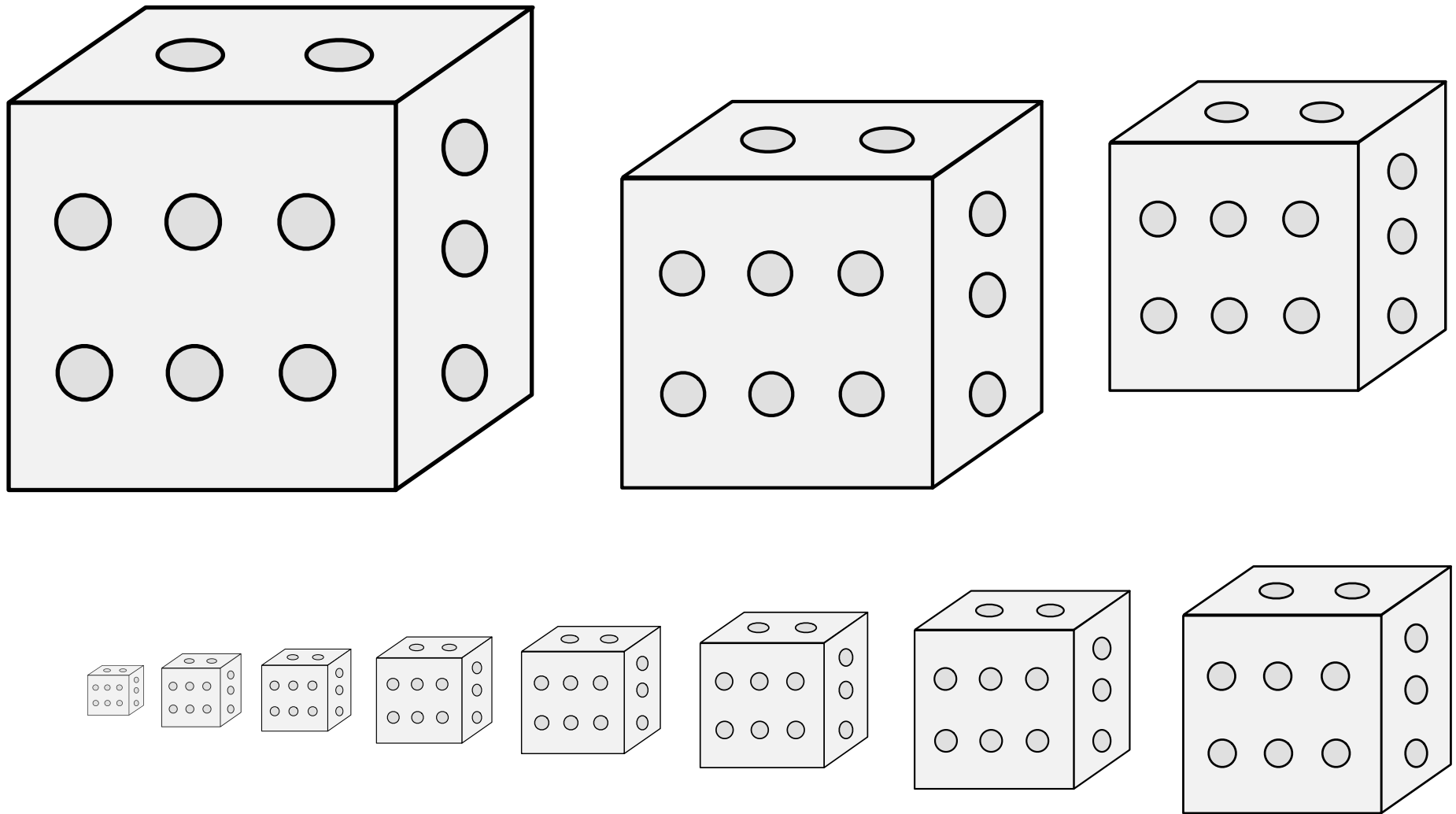

A generator of random outcomes.

Default orientation: affronty, often in trian aspect. No proper coloration.

Blazoned “a die *tincture* marked (or spotted) *tincture*.”

Source: A Glossary of Terms Used in Heraldry. Artist: James or Irene Parker.
Adapted by Mathghamhain Ua Ruadháin.

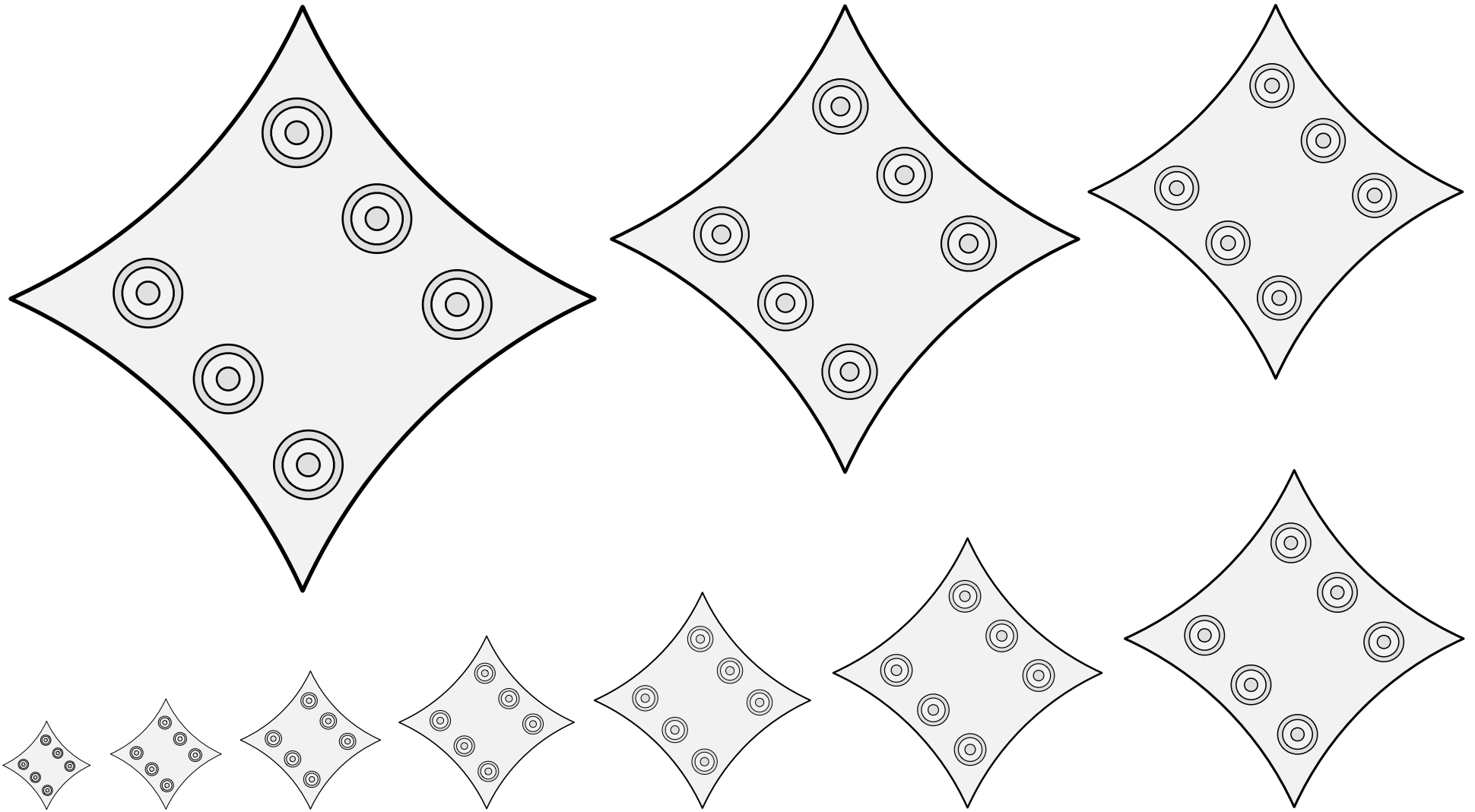

A generator of random outcomes.

Default orientation: affronty, often in trian aspect. No proper coloration.

Blazoned "a die *tincture* marked (or spotted) *tincture*."

Source: Wappenbuch der Bruderschaft des heiligen Christophorus am Arlberg. Artist unknown.

Die (3) 18.75

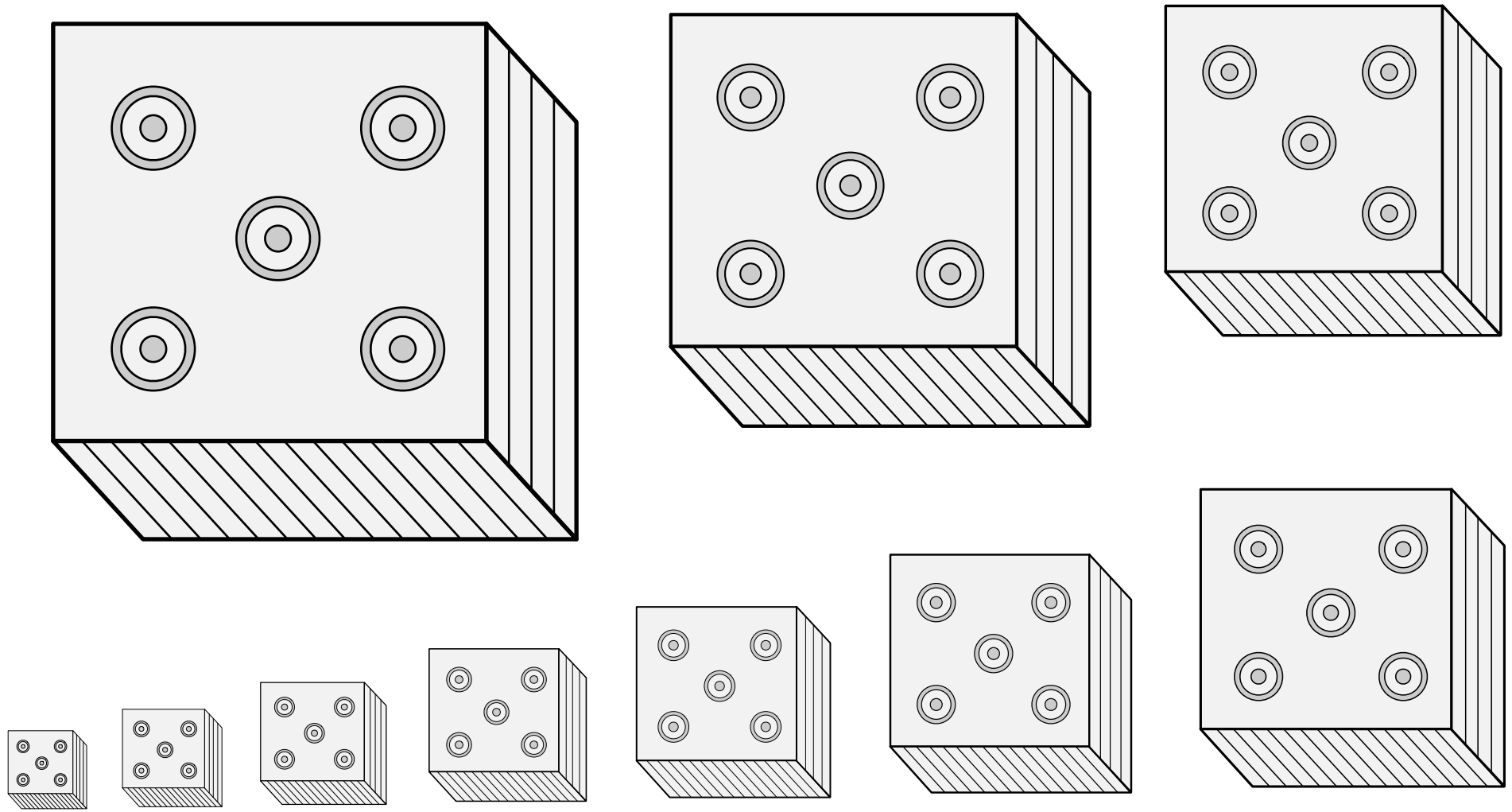

A generator of random outcomes.

Default orientation: affronty, often in trian aspect. No proper coloration.

Blazoned “a die *tincture* marked (or spotted) *tincture*.”

Source: Guillim’s Display of Heraldry. Artist unknown.

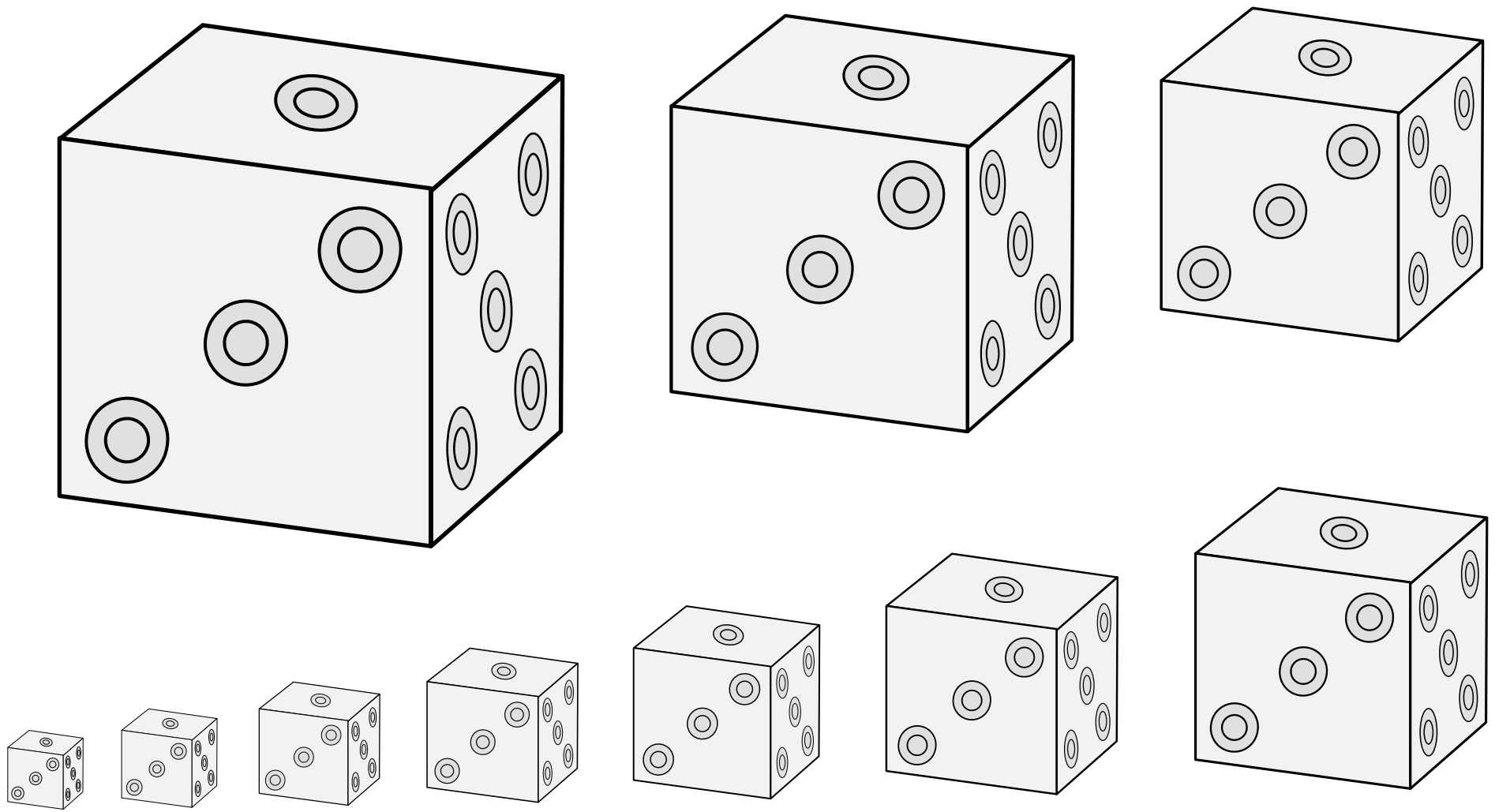

A generator of random outcomes.

Default orientation: affronty, often in trian aspect. No proper coloration.

Blazoned “a die *tincture* marked (or spotted) *tincture*.”

Source: Viking Answer Lady SVG Images For Heralds. Artist: Gunnvôr silfráhr.

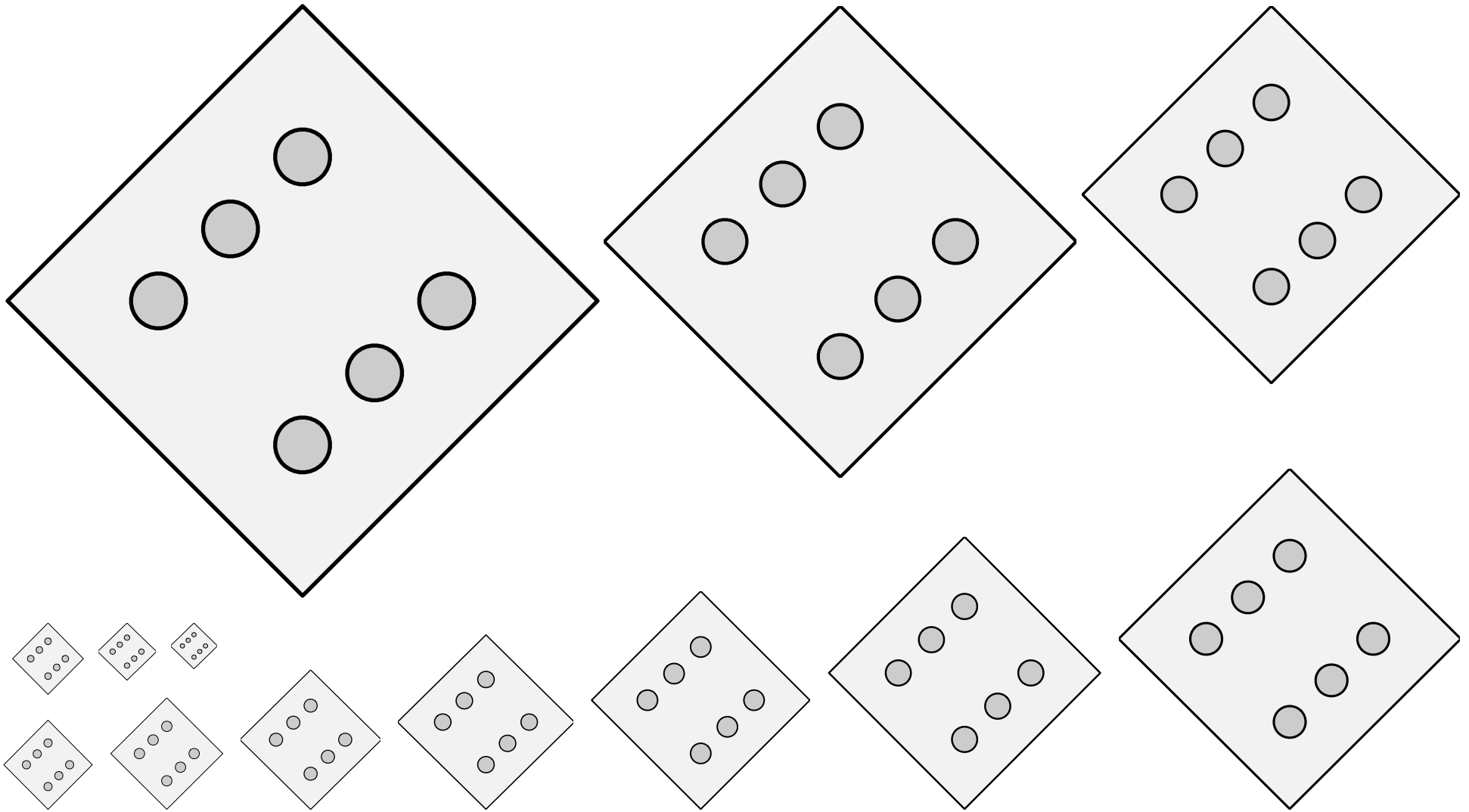

A generator of random outcomes.

Default orientation: affronty, often in trian aspect. No proper coloration.

Blazoned “a die *tincture* marked (or spotted) *tincture*.”

Source: Neustifter Wappenbuch. Artist: Vigil Raber. (Page 16.)

Die (6) 18.78

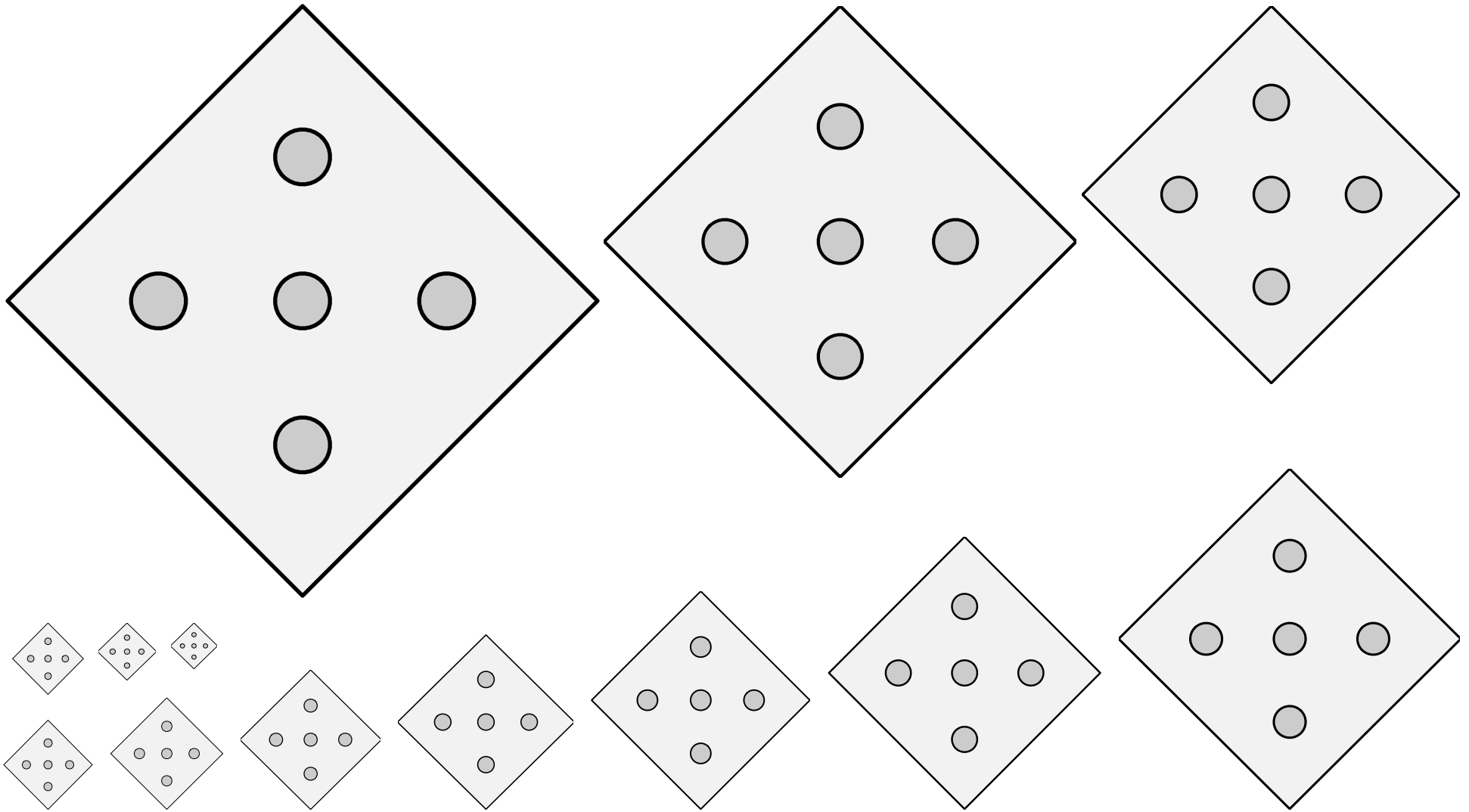

A generator of random outcomes.

Default orientation: affronty, often in trian aspect. No proper coloration.

Blazoned “a die *tincture* marked (or spotted) *tincture*.”

Source: Neustifter Wappenbuch. Artist: Vigil Raber. (Page 16.)

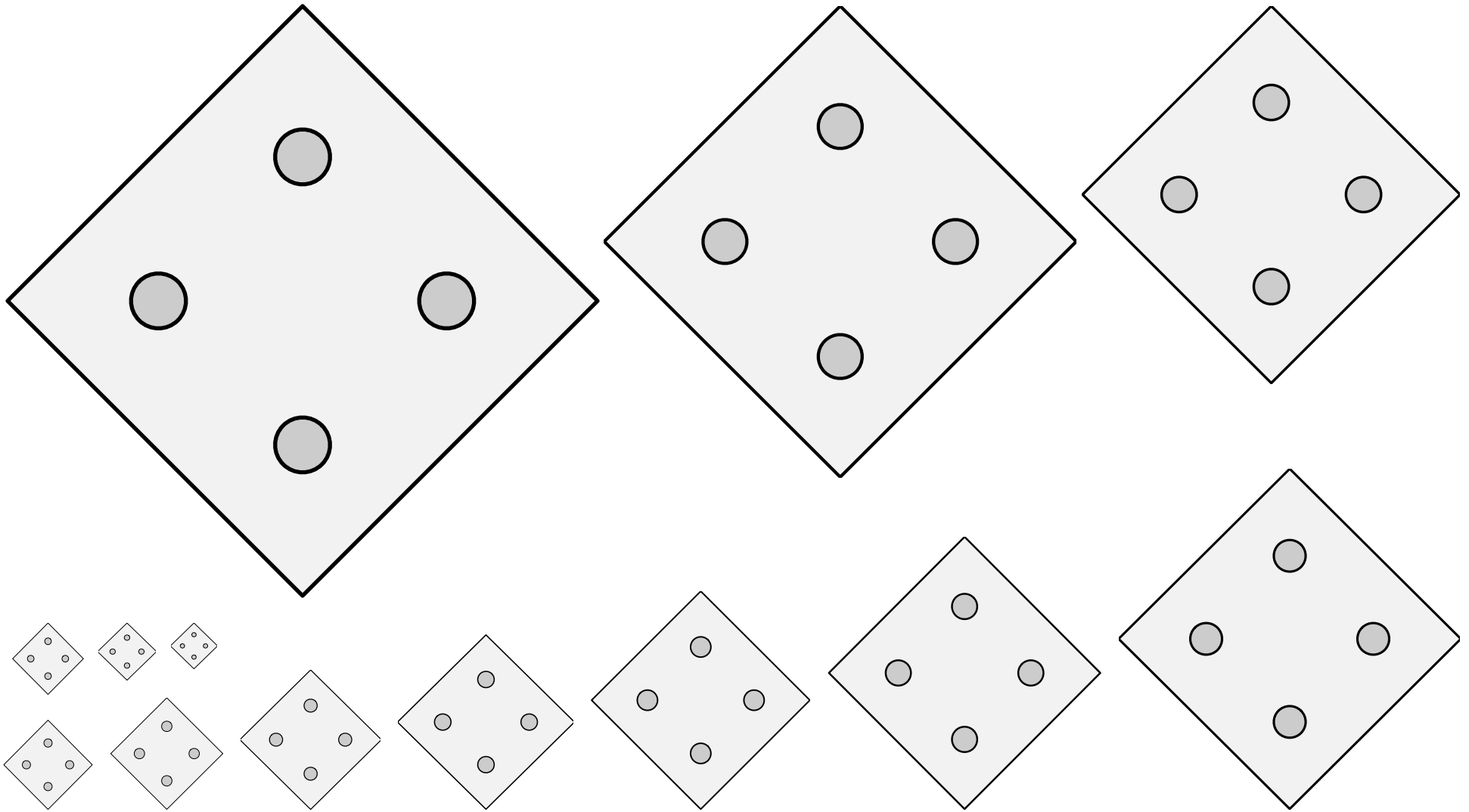

A generator of random outcomes.

Default orientation: affronty, often in trian aspect. No proper coloration.

Blazoned “a die *tincture* marked (or spotted) *tincture*.”

Source: Neustifter Wappenbuch. Artist: Vigil Raber. (Page 16.)

Die (8) 18.80

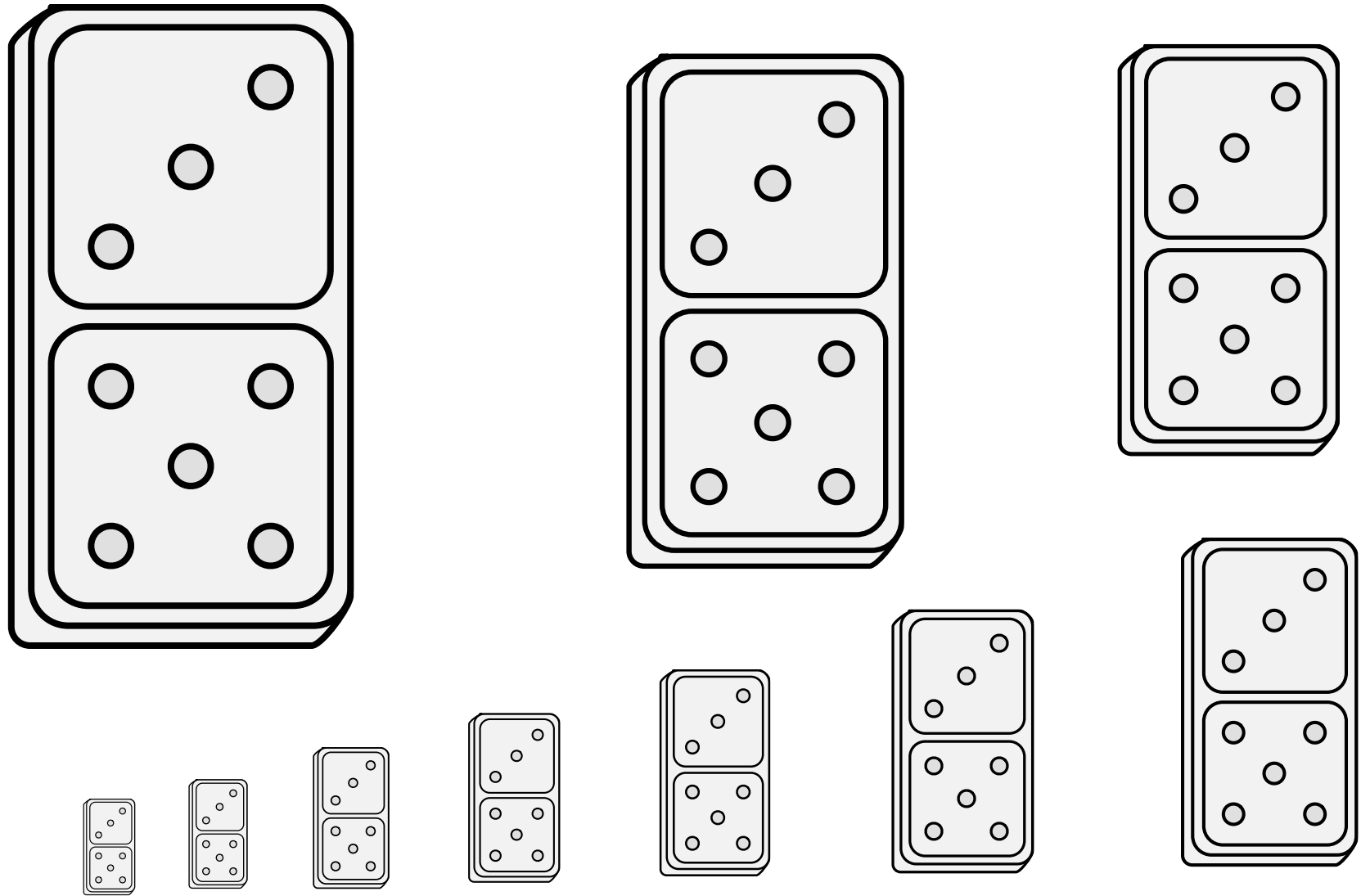

A tile used in table-top gaming. Dominoes were invented in China by the 13th century, but did not become popular in Europe until the early 18th century.

No default orientation. No proper coloration.

Blazoned “a domino *tincture* marked (or spotted) *tincture*.”

Source: Pennsic Traceable Art. Artist unknown. Adapted by Mathghamhain Ua Ruadháin.

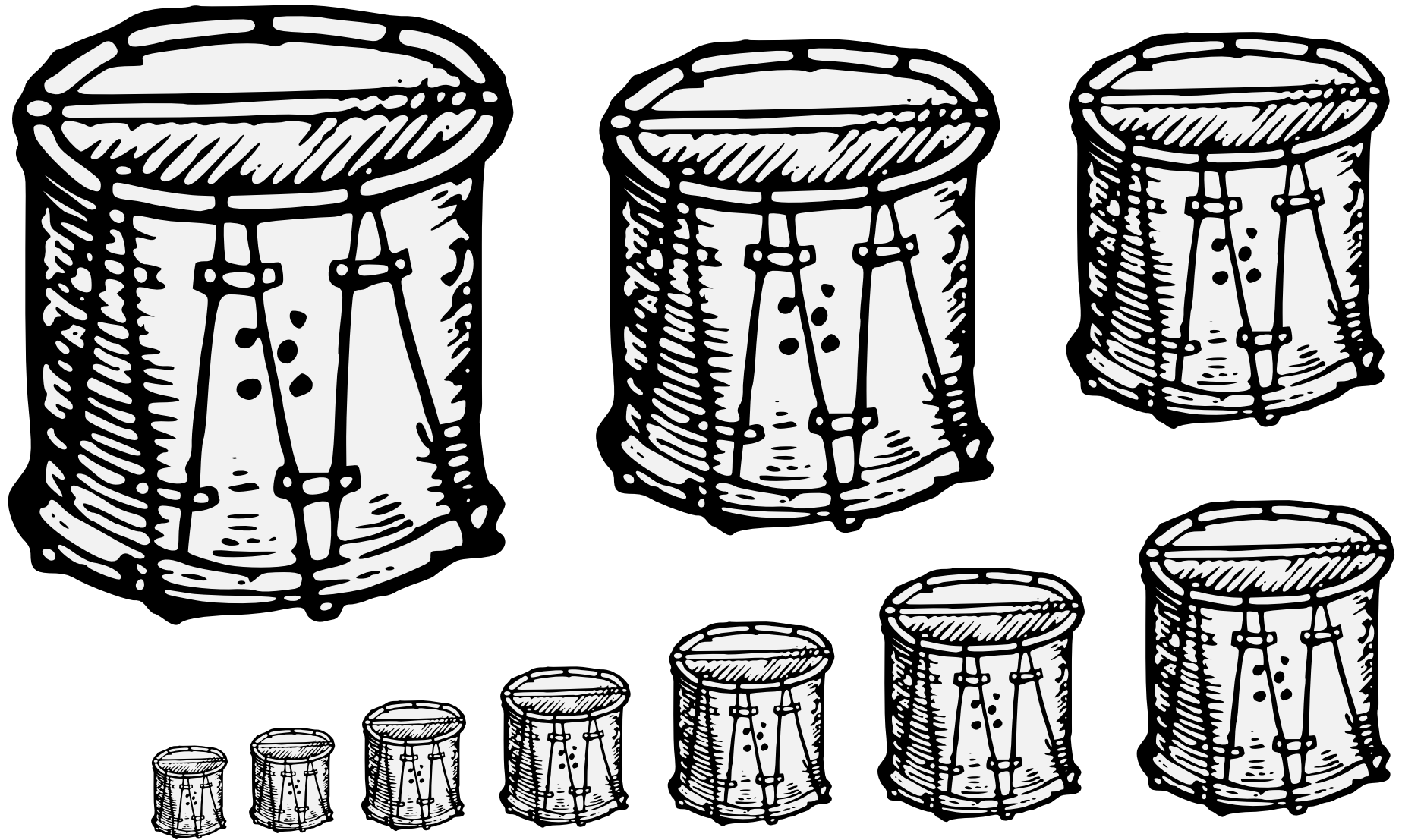

A percussion instrument.

Default orientation: head to chief. No proper coloration.

Source: Guillim's Display of Heraldry. Artist unknown.

Drum 18.83



A percussion instrument. Also spelled “dumbeg.” Found in Islamic culture.
Default orientation: palewise. Proper coloration: brown wood, argent skin.
Source: Pennsic Traceable Art. Artist: Unknown.

Drum, Dumbek (1) 18.84

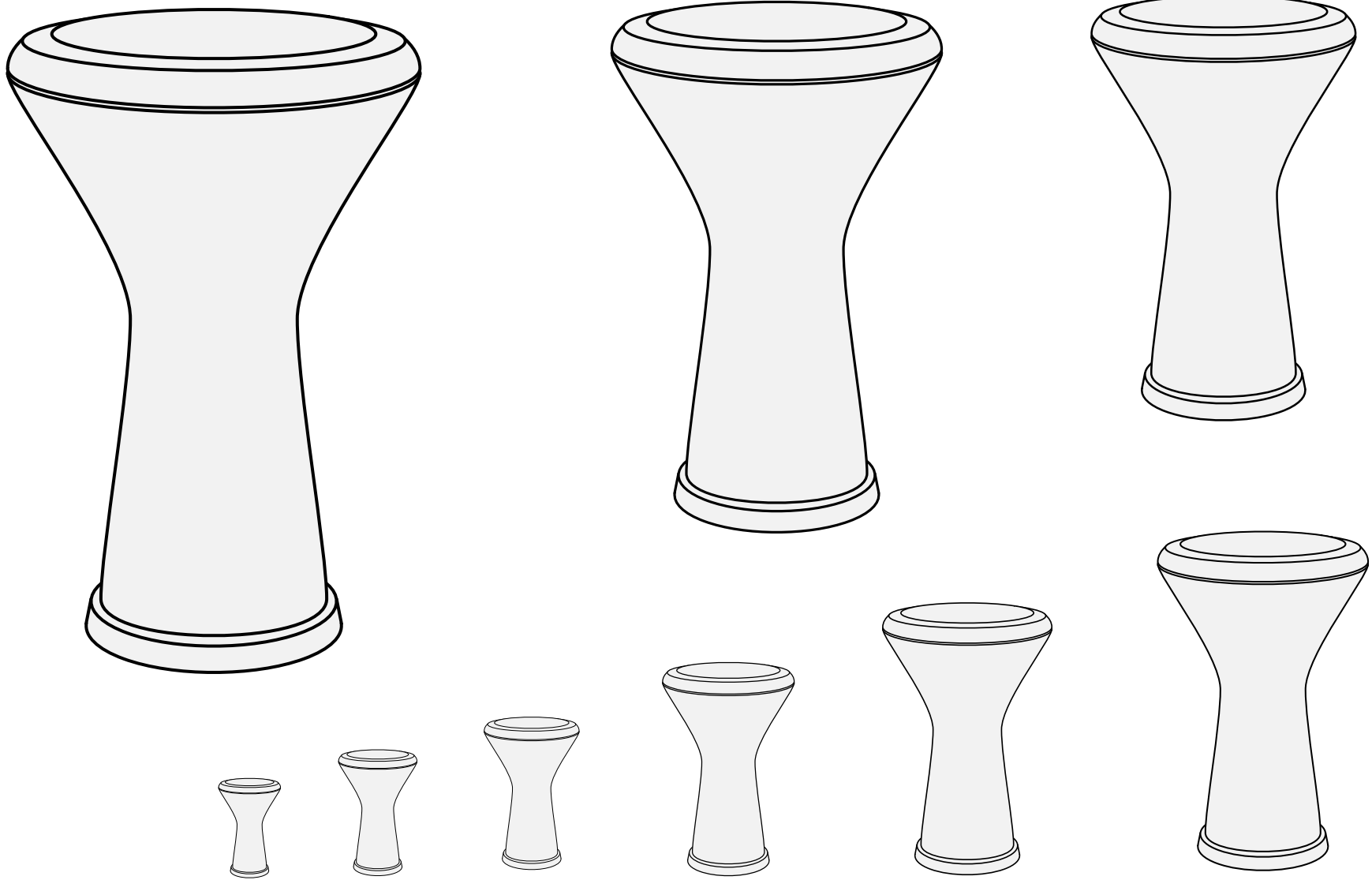

A percussion instrument. Also spelled “dumbeg.” Found in Islamic culture.
Default orientation: palewise. Proper coloration: brown wood, argent skin.

Drum, Dumbek (2) 18.85

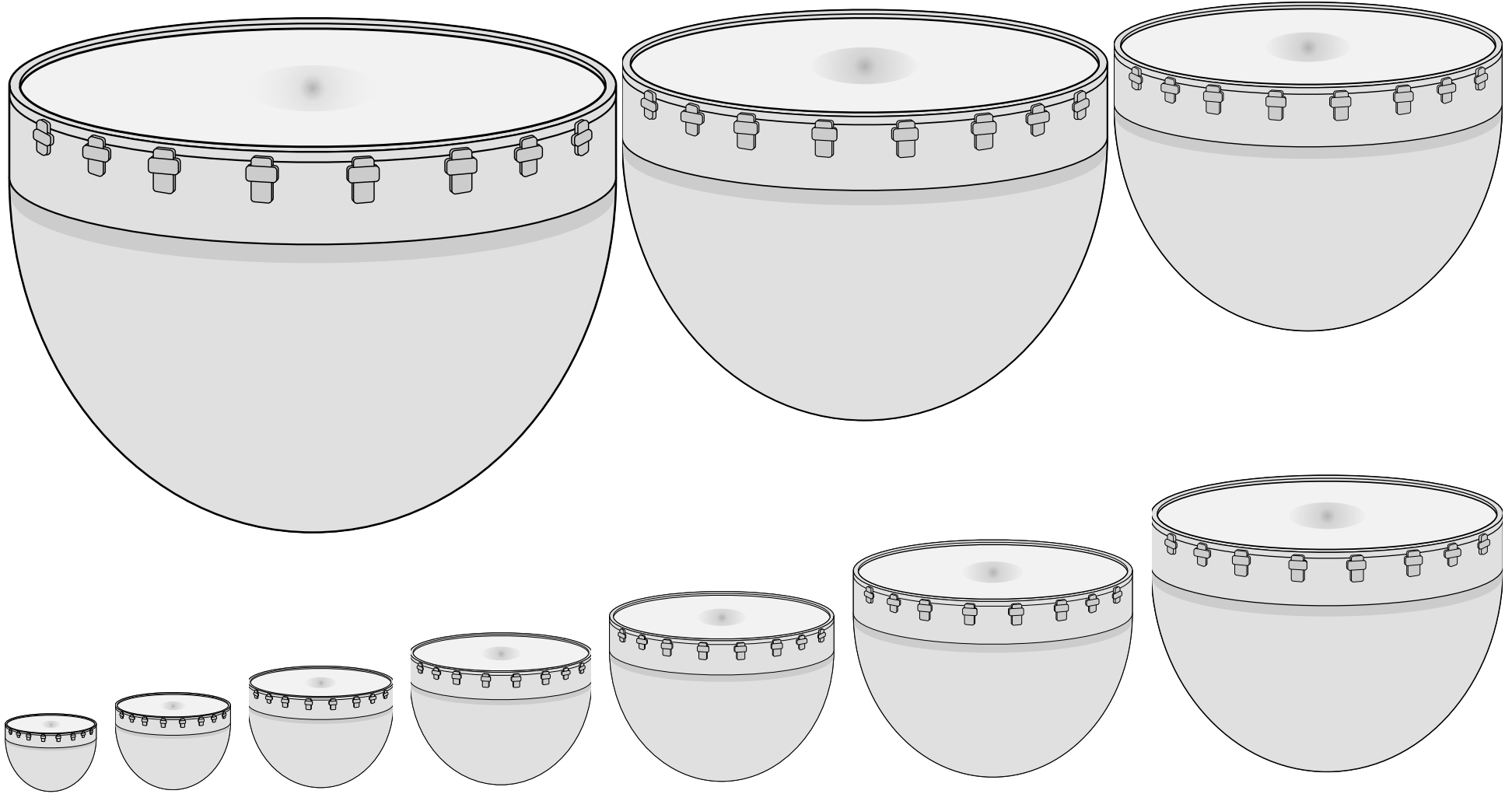

A percussion instrument.

Default orientation: head to chief. No proper coloration.

Source: Stammbaum Kaiser Karls IV. Artist unknown. (Page 160.)

Drum, Kettle (1) 18.86

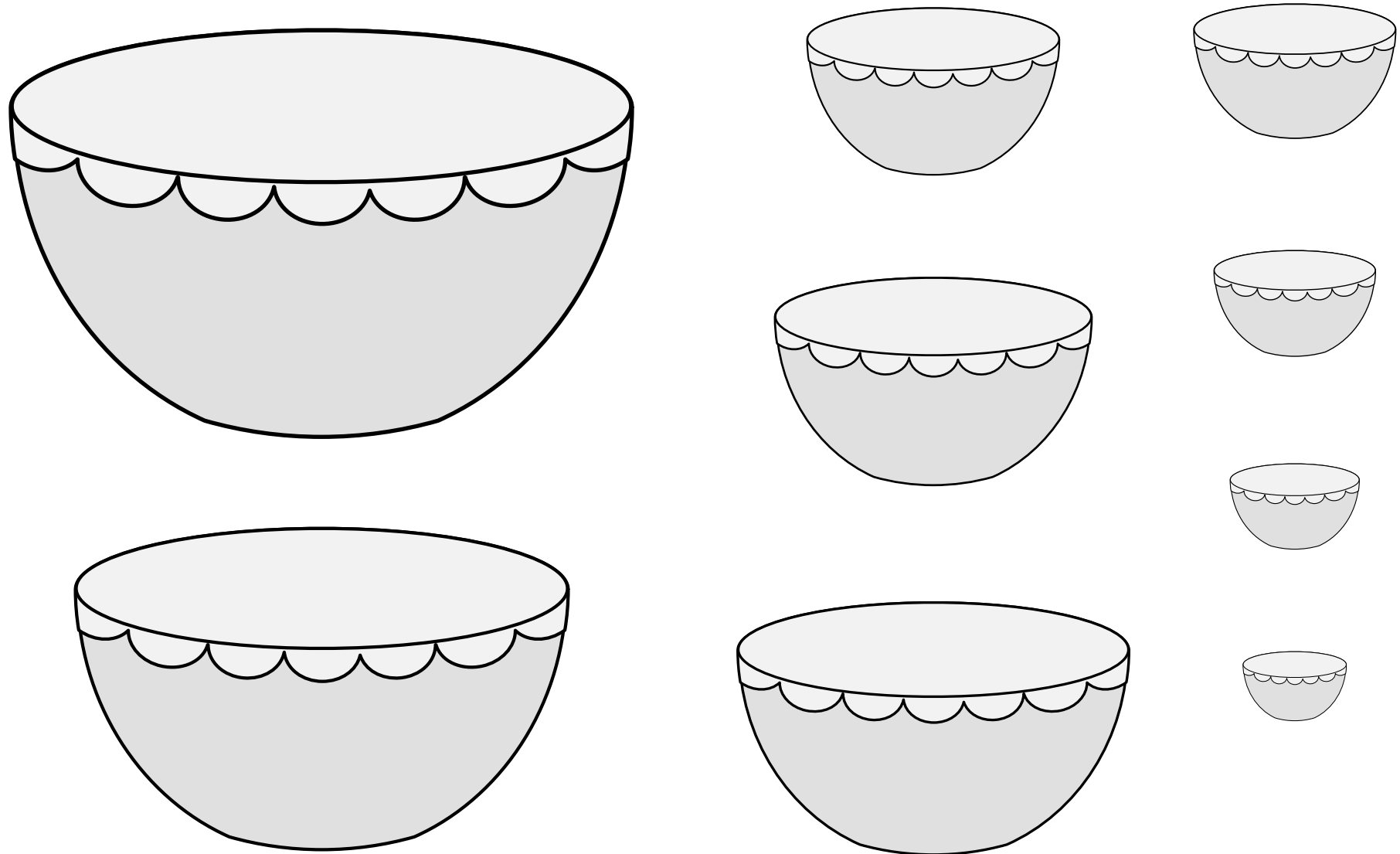

A percussion instrument.

Default orientation: head to chief. No proper coloration.

Artist: Mathghamhain Ua Ruadháin.

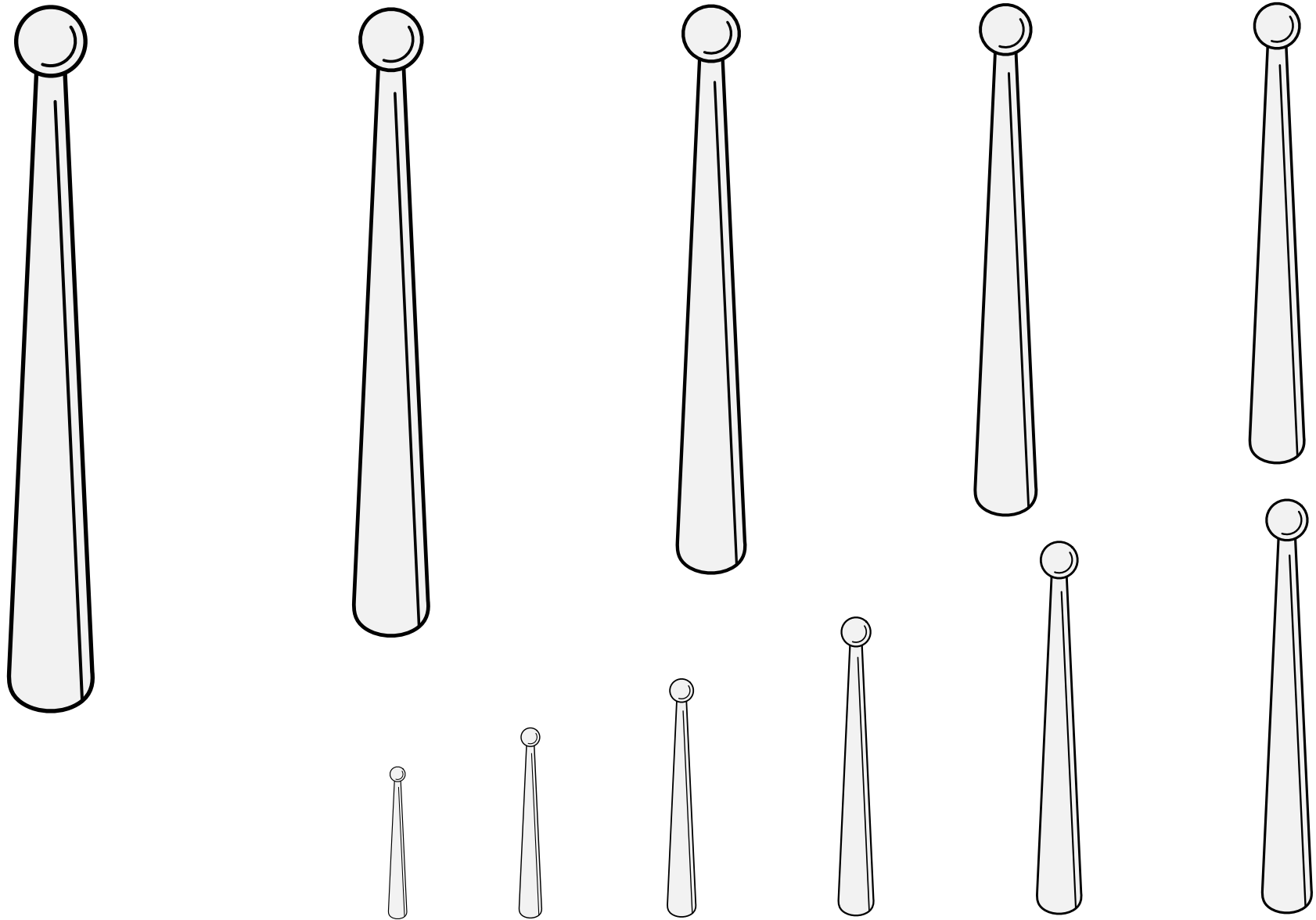

A percussion instrument.

Default orientation: palewise, head to chief. Proper coloration: brown wood.

Source: Guillim's Display of Heraldry. Artist unknown.
Adapted by Mathghamhain Ua Ruadháin.

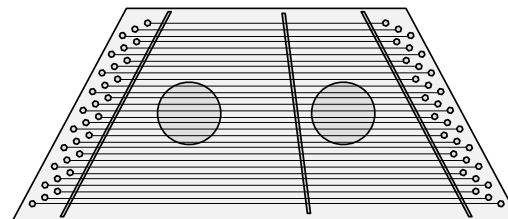
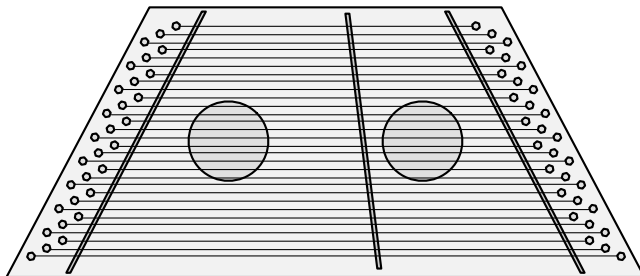
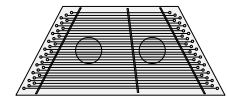
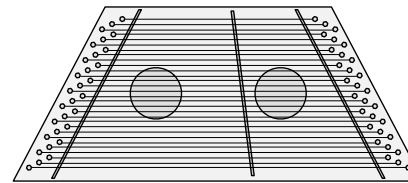
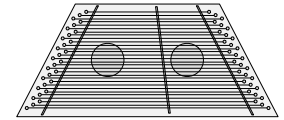
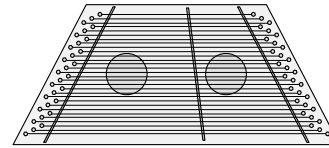
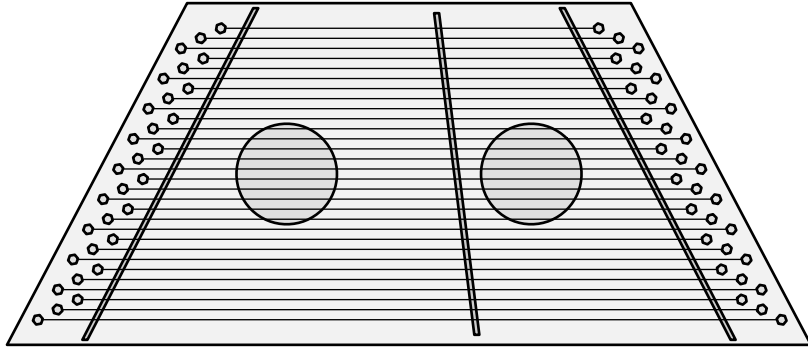

A Renaissance-era string instrument, played by hammering the strings.

Dulcimer 18.89

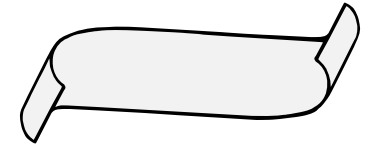
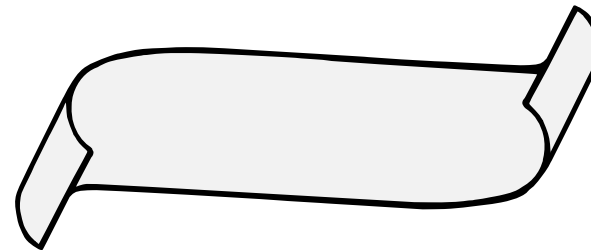
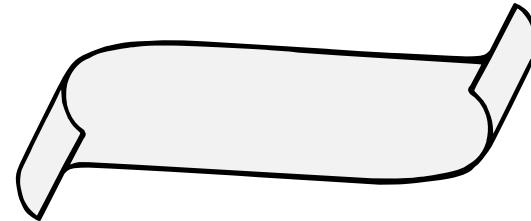
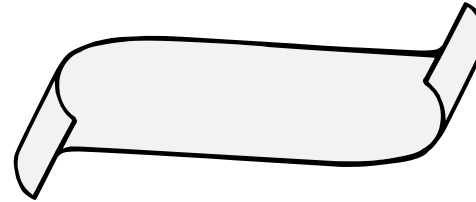
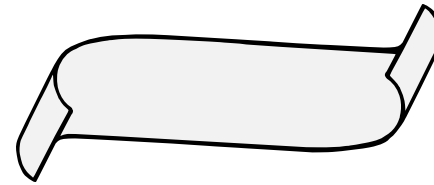
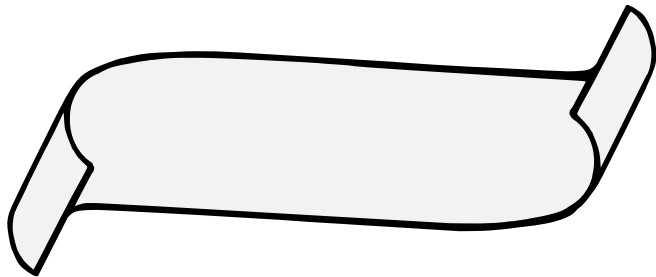
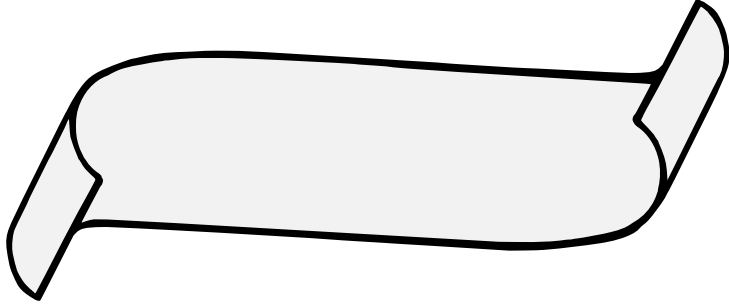
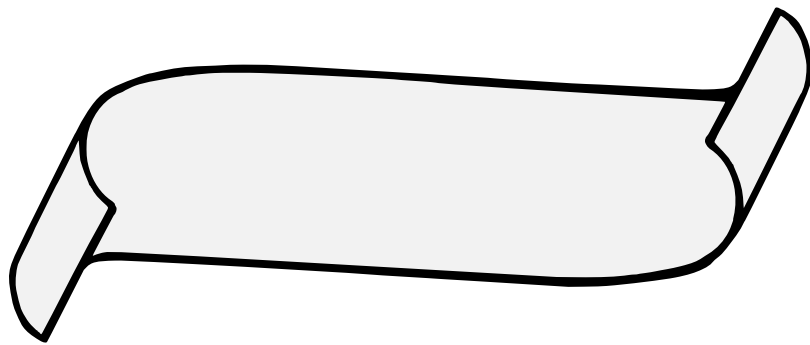

A small piece of parchment, which always appears with another charge piercing it.

No default orientation. No proper coloration.

Artist: Jessimond of Emerickeskepe.

Escroll Fesswise 18.90

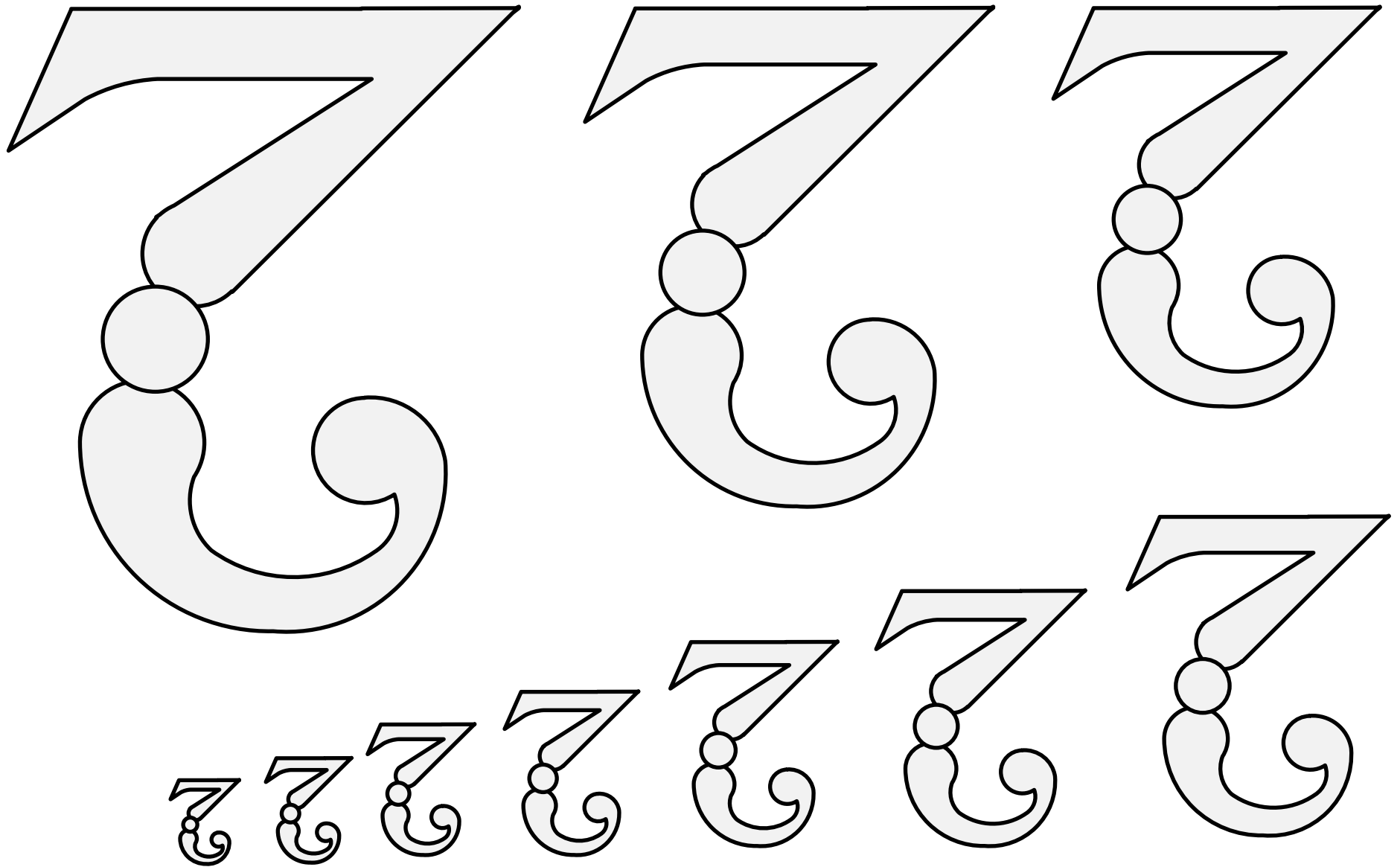

A surgeon's knife, associated with bloodletting.

Default alignment: blade to chief, curved handle to base. No proper coloration.

Source: Viking Answer Lady SVG Images For Heraldry. Artist: Gunnvôr silfráhr.

Fleam (1) • 18.91

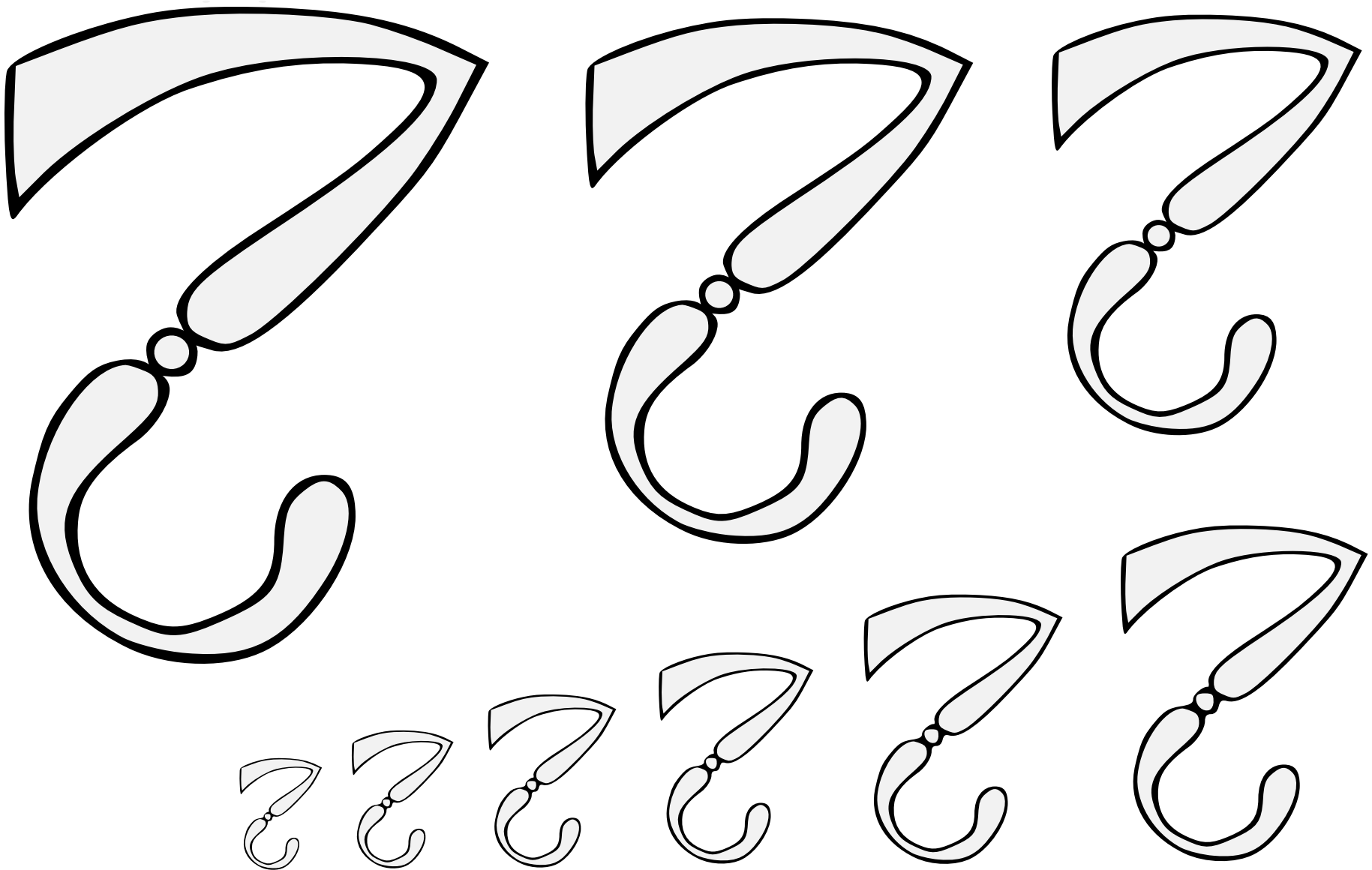

A surgeon's knife, associated with bloodletting.

Default alignment: blade to chief, curved handle to base. No proper coloration.

Source: Pennsic Traceable Art. Artist: Bressel McCulloch.

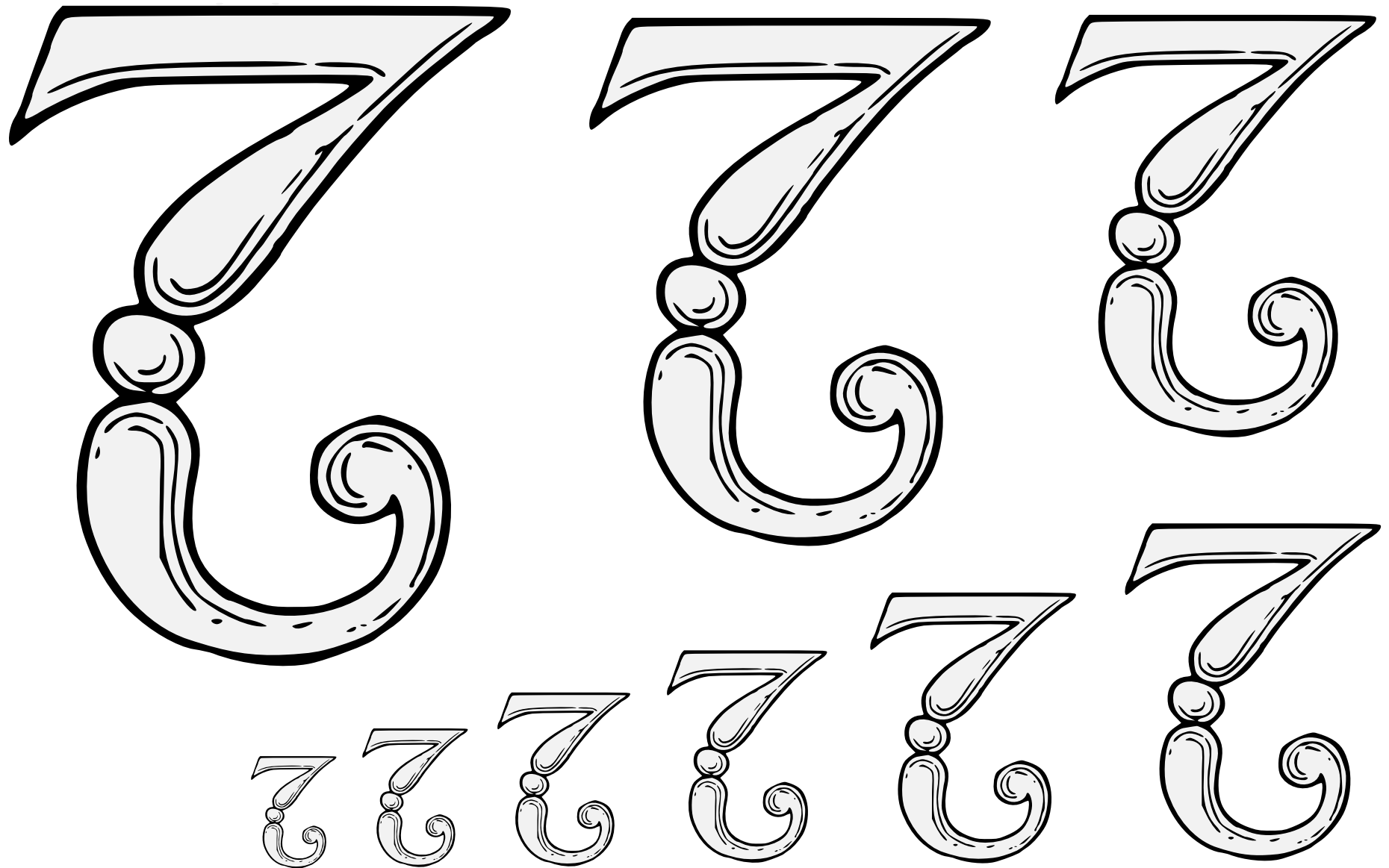

A surgeon's knife, associated with bloodletting.

Default alignment: blade to chief, curved handle to base. No proper coloration.

Source: A Complete Guide to Heraldry. Artist: Graham Johnston.

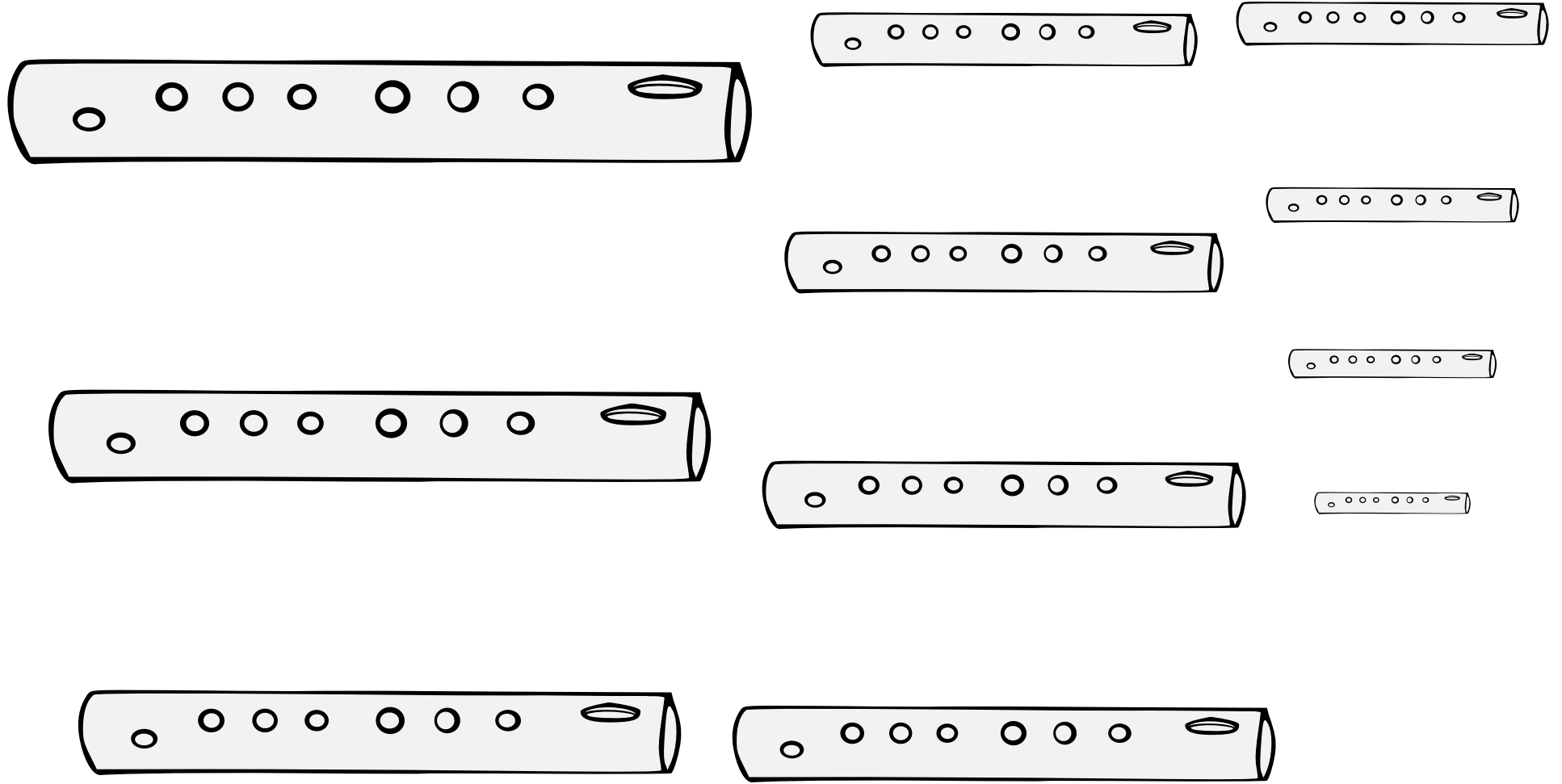

A wind instrument.

No default orientation. No proper coloration.

Source: Pennsic Traceable Art. Artist: Unknown.

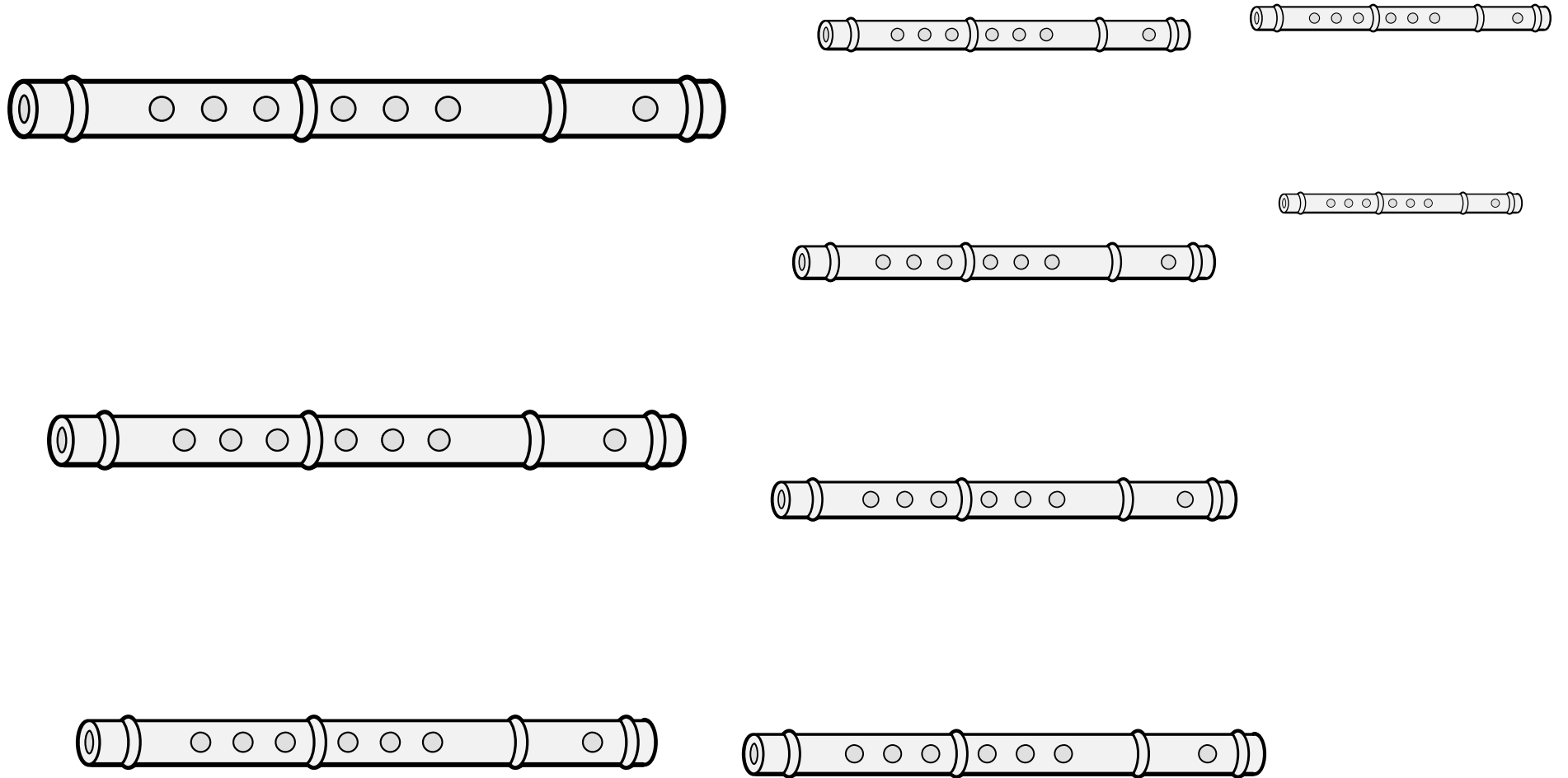

A wind instrument.

No default orientation. No proper coloration.

Source: Viking Answer Lady SVG Images For Heraldists. Artist: Gunnvôr silfrahárr.

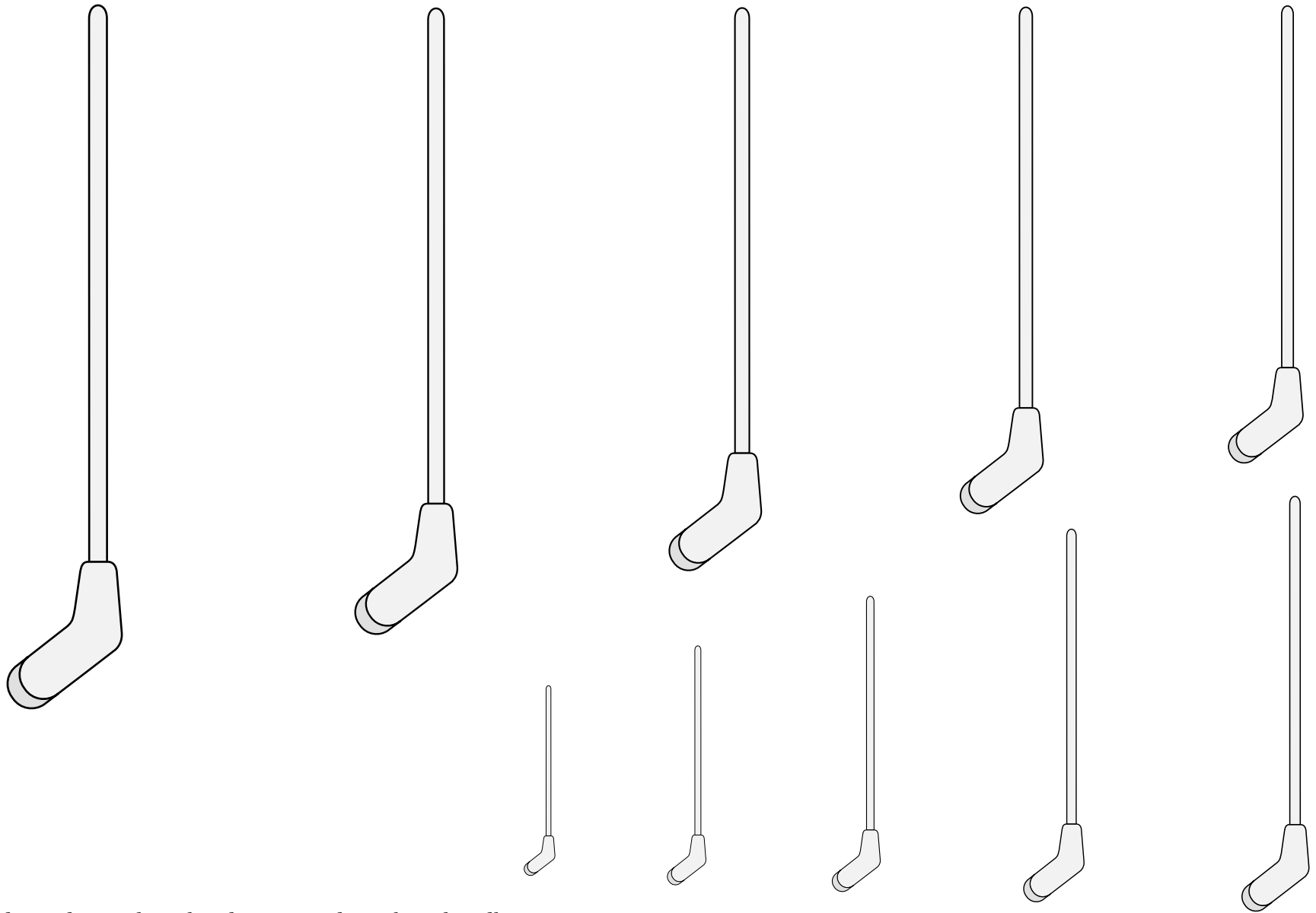

An angled wooden striking head connected to a long handle.

Default orientation: club to base. No proper coloration.

Adapted from Simon Bening's book of hours. (Circa 1540, also called "the Golf Book," page 18.)
Adapted by Mathghamhain Ua Ruadháin.

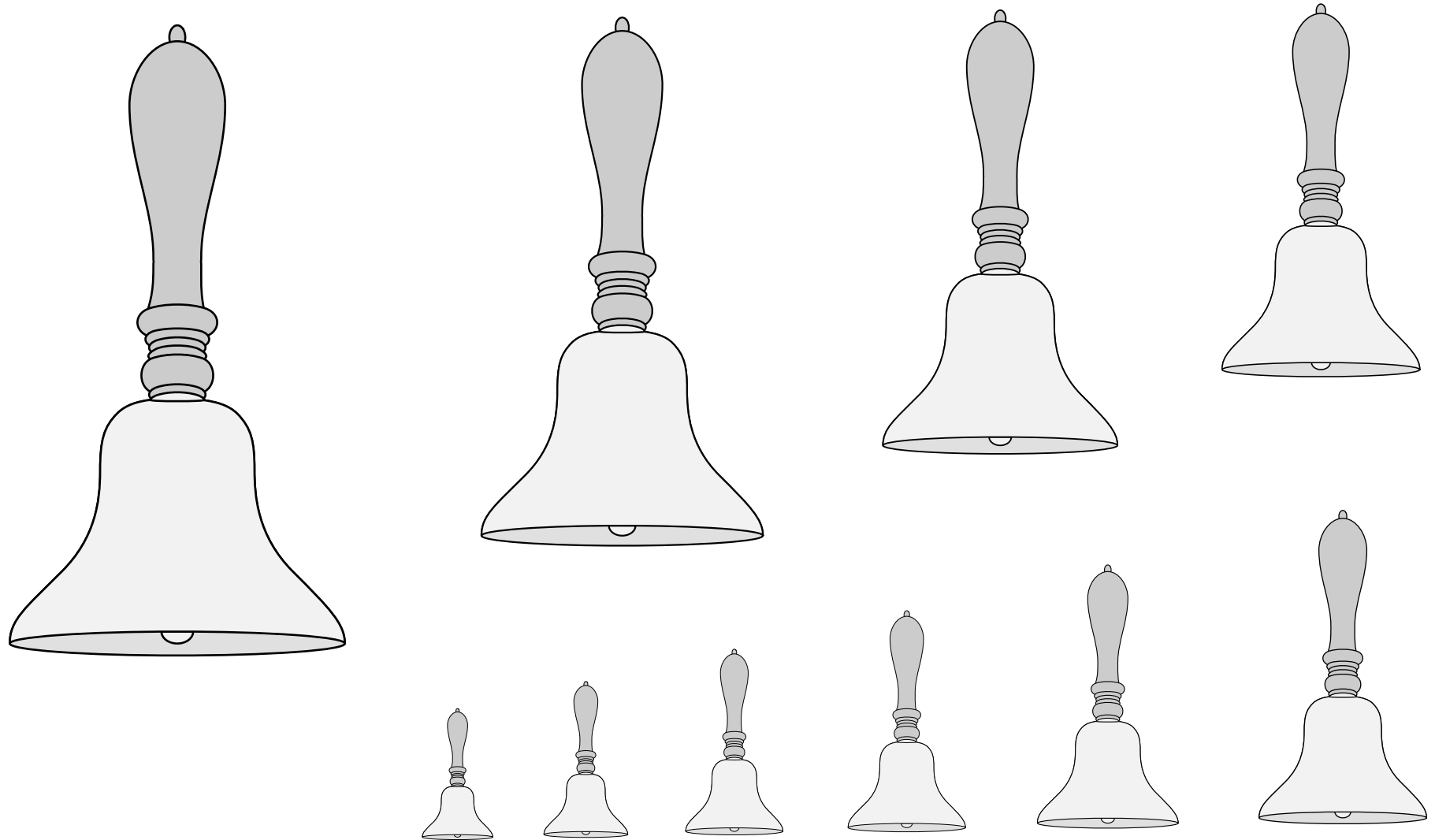

A bell attached to a short handle that allows it to be carried and rung.
Default orientation: handle to chief. No proper coloration.

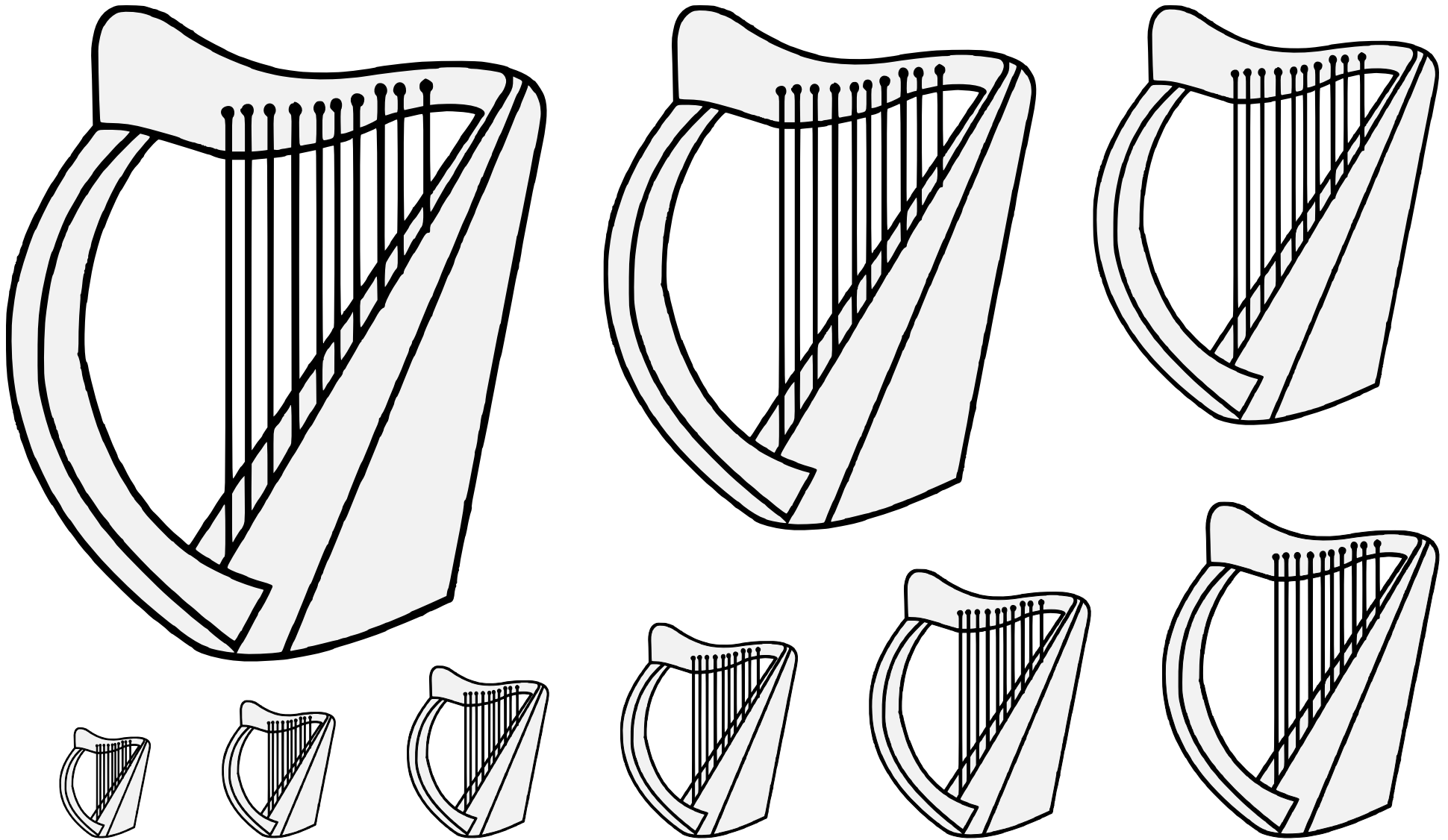

A stringed musical instrument.

Default orientation: upright. No proper coloration.

Source: Pennsic Traceable Art. Artist unknown.

Harp (1) 18.98

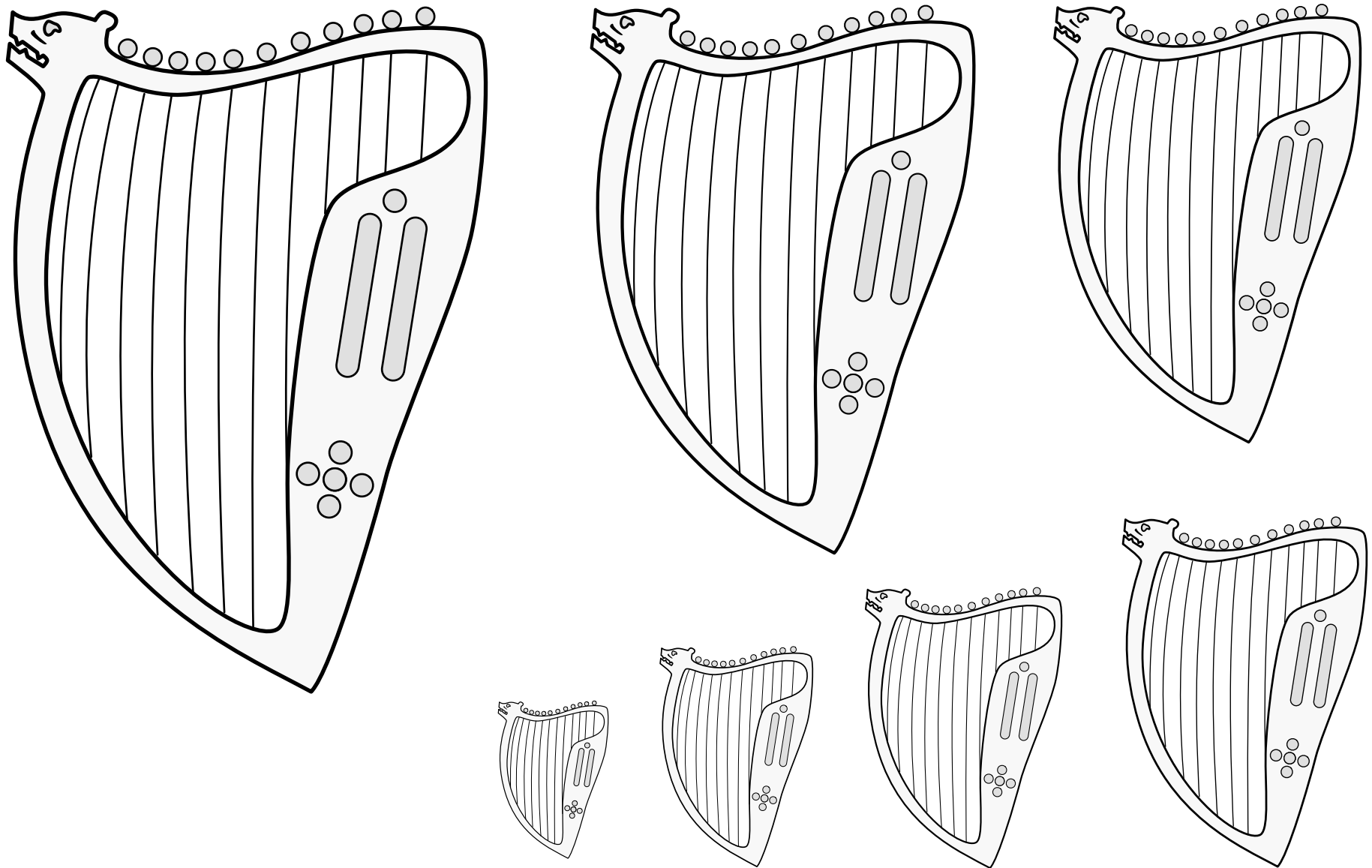

A stringed musical instrument.

Default orientation: upright. No proper coloration.

Source: Manesse Codex. Artist unknown. (Folio 182v.)

Adapted by Mathghamhain Ua Ruadháin.

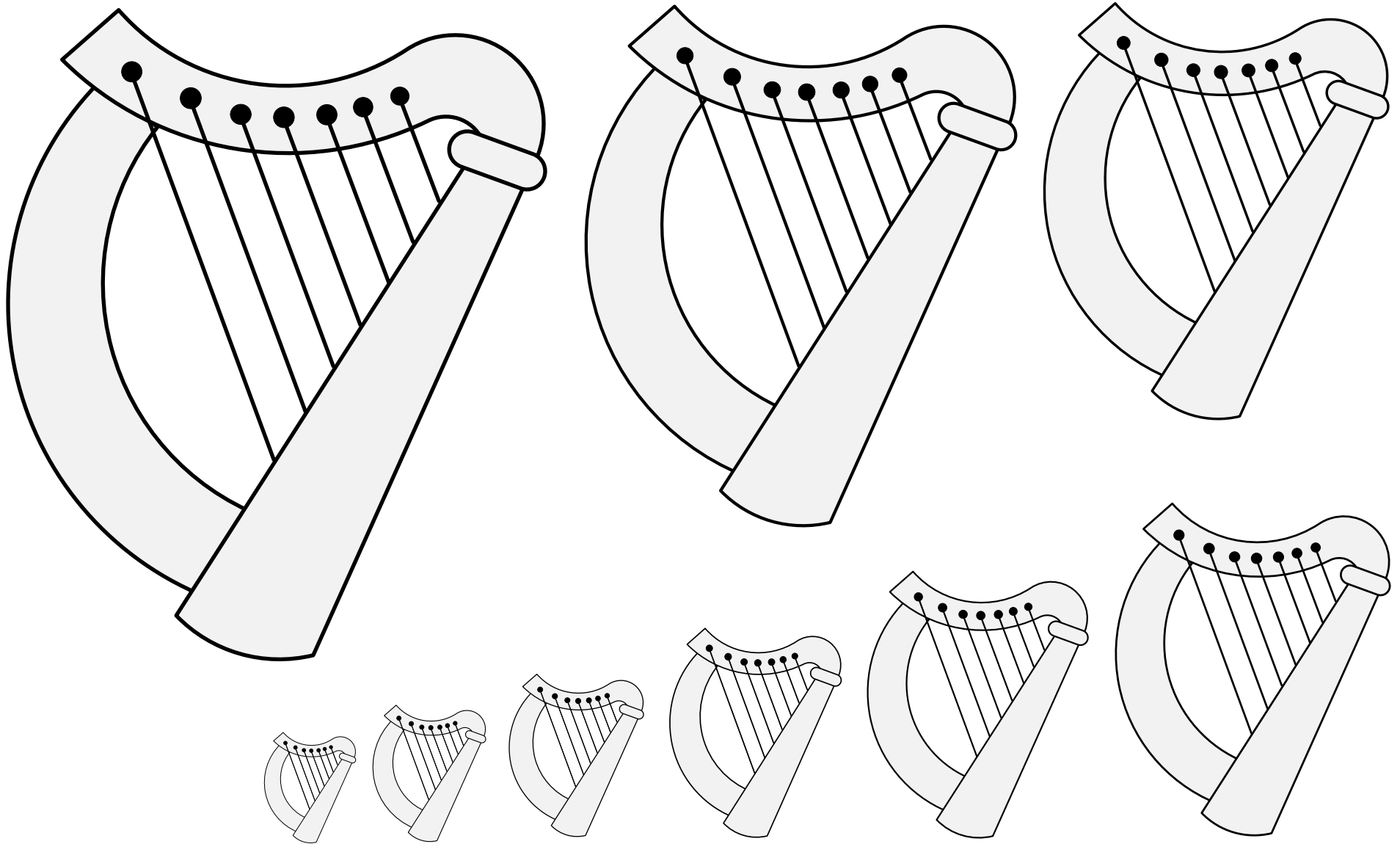

A stringed musical instrument.

Default orientation: upright. No proper coloration.

Source: Viking Answer Lady SVG Images For Heraldists. Artist: Gunnvör silfrahárr.

Harp (3) 18.100

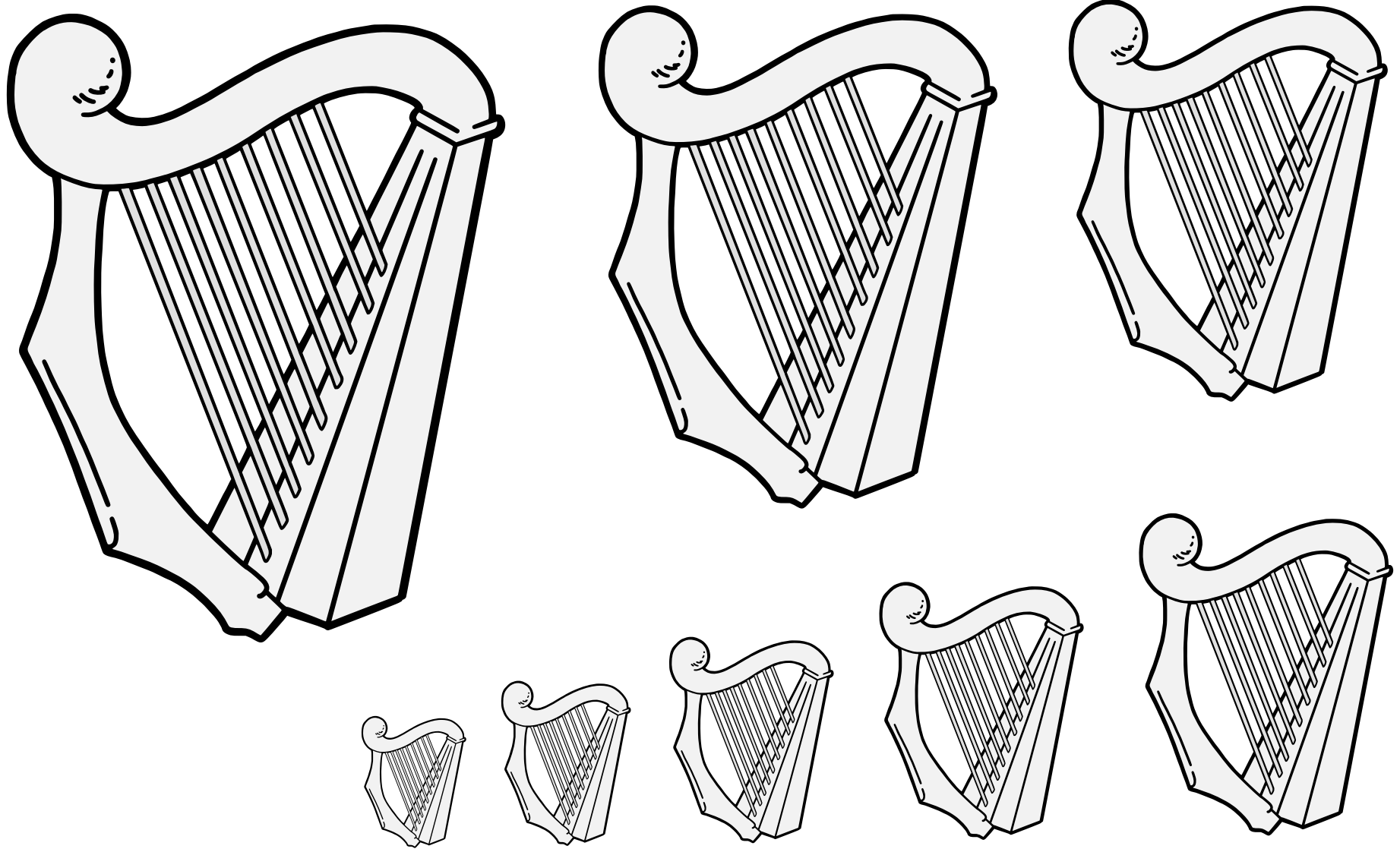

A stringed musical instrument.

Default orientation: upright. No proper coloration.

Artist: Ajir Tsagaan.

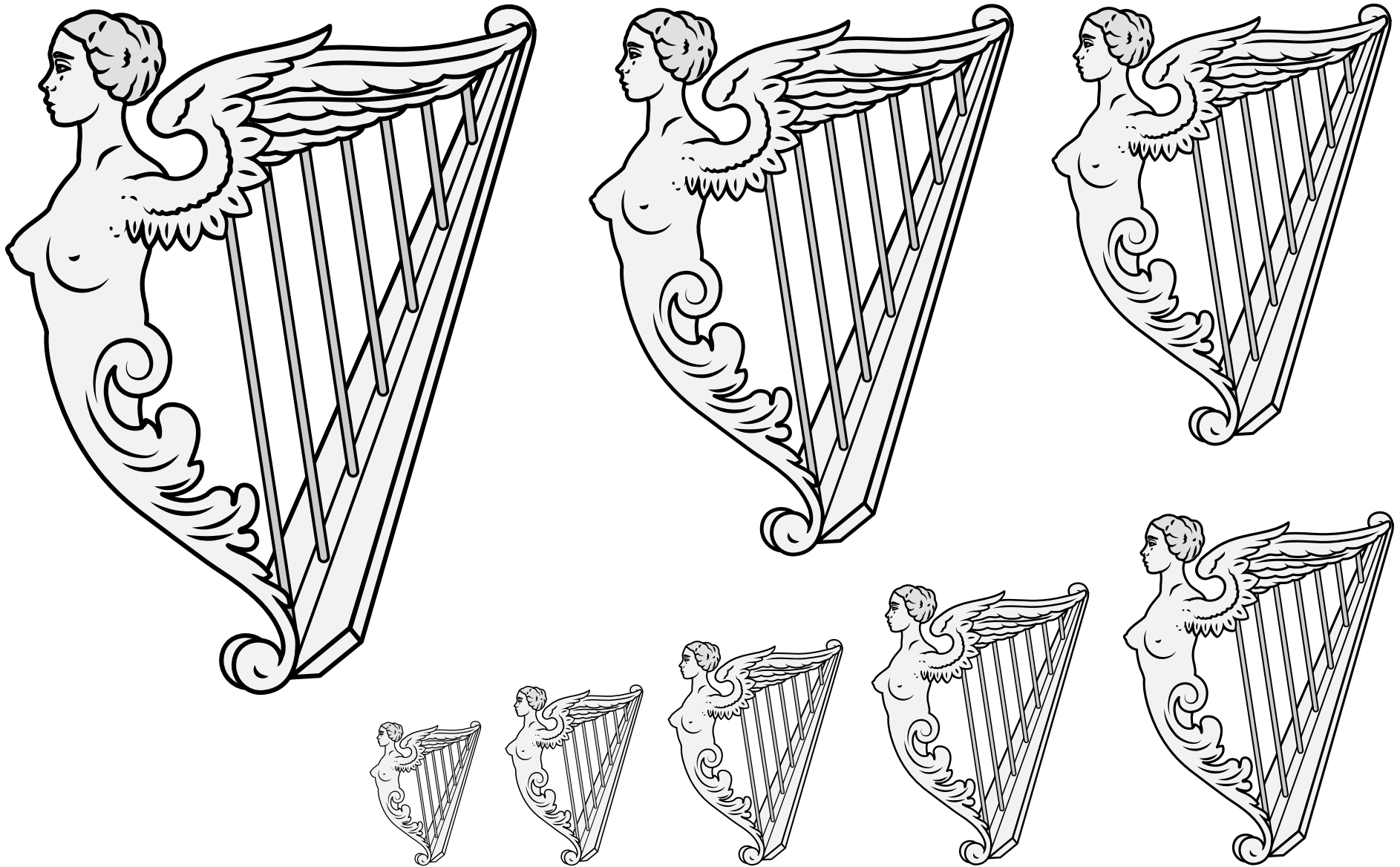

A stringed musical instrument.

Default orientation: upright. No proper coloration.

Source: WappenWiki. Artist: Joakim Spuller. Adapted by Finellach.

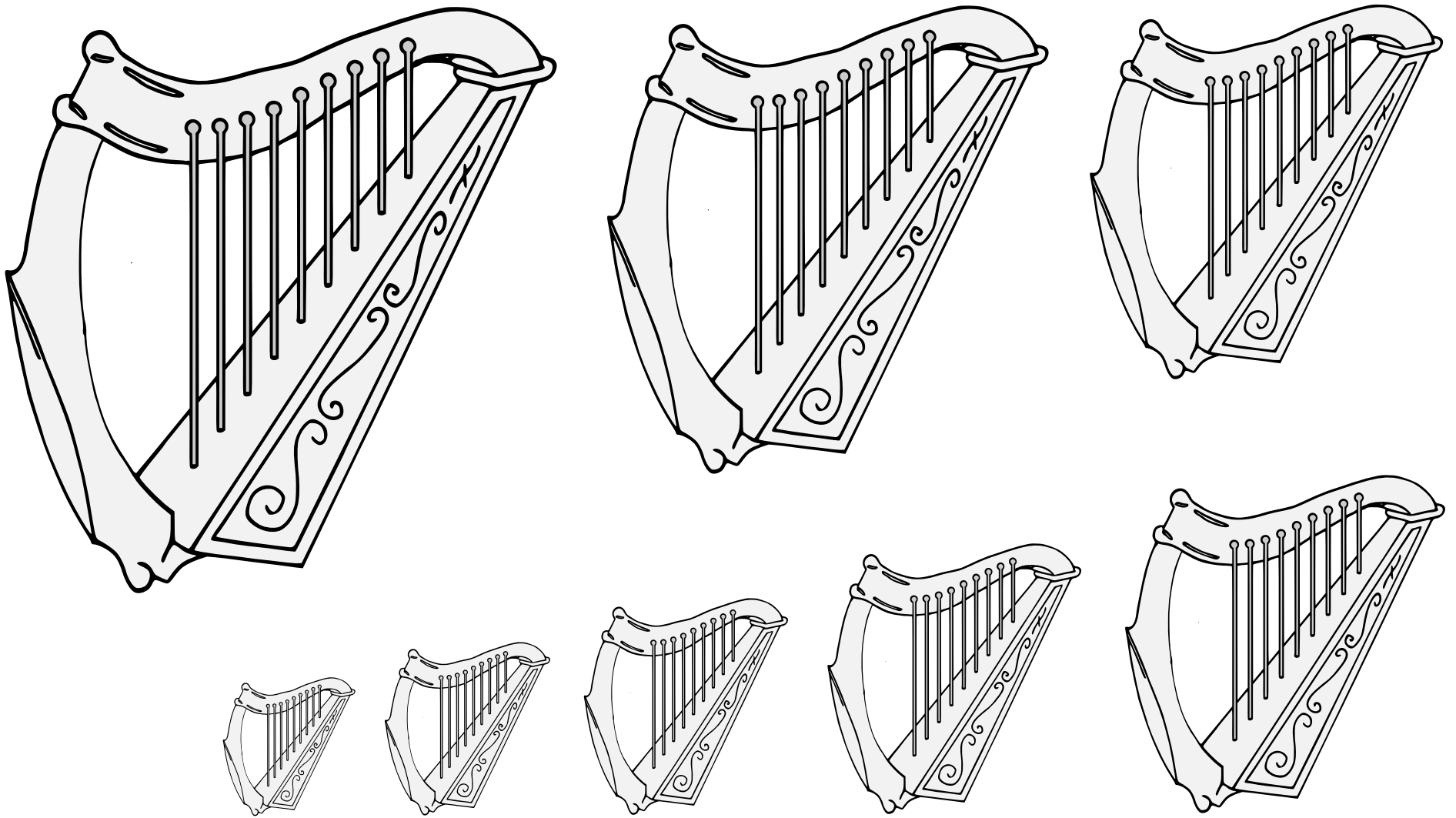

A stringed musical instrument.

Default orientation: upright. No proper coloration.

Source: Heraldic Templates. Artist: Torric inn Björn.

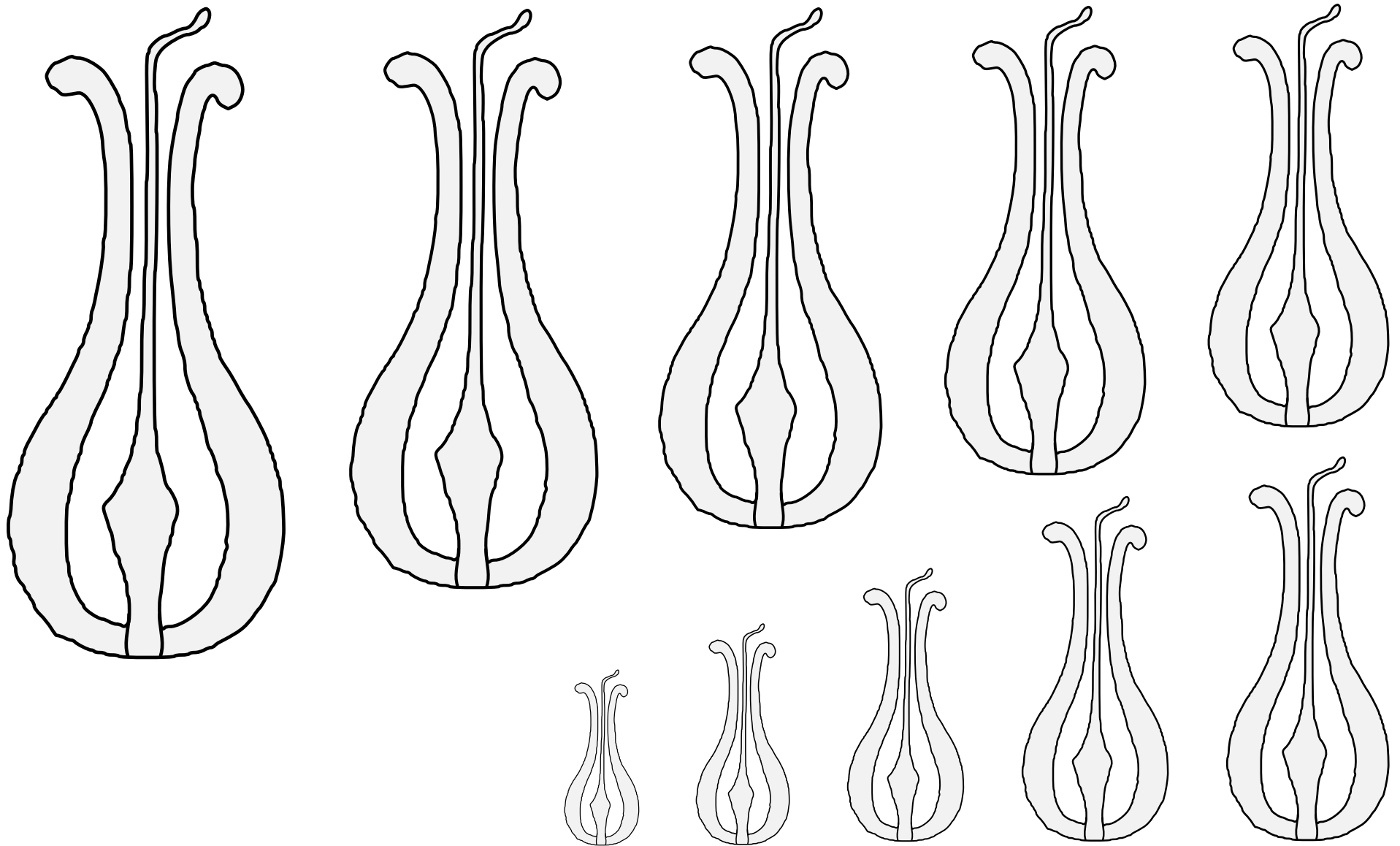

A musical instrument played with one's mouth; also blazoned a "Jew's Harp."

Default orientation: ends to chief. No proper coloration.

Source: Encyclopædia Heraldica. (Volume 3, plate XII.) Artist unknown.

Harp, Mouth (1) 18.104

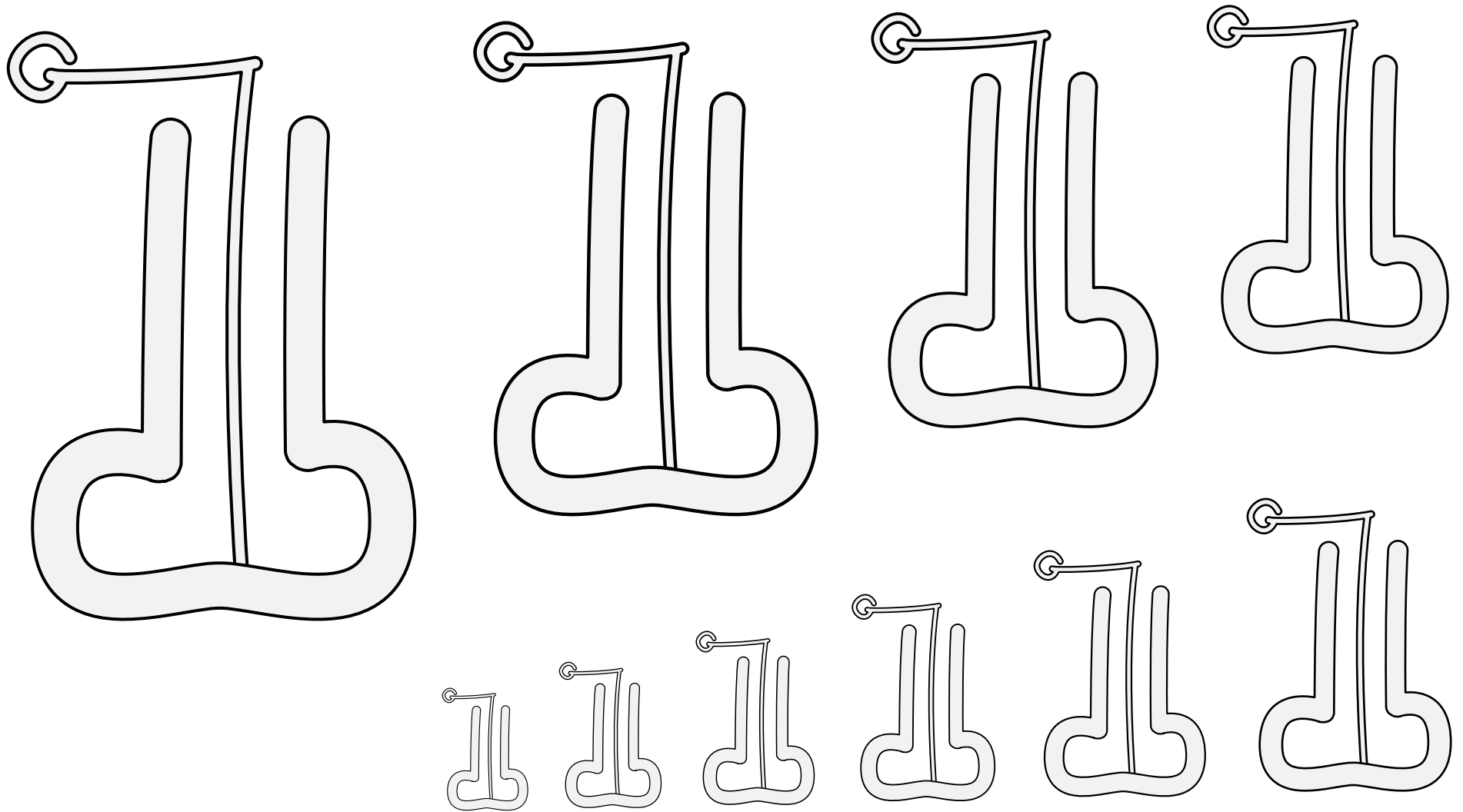

A musical instrument played with one's mouth; also blazoned a "Jew's Harp."

Default orientation: ends to chief. No proper coloration.

Source: Wappenbuch der Arlberg-Bruderschaft. Artist: Vigil Raber. (Page 120.)

Harp, Mouth (2) 18.105

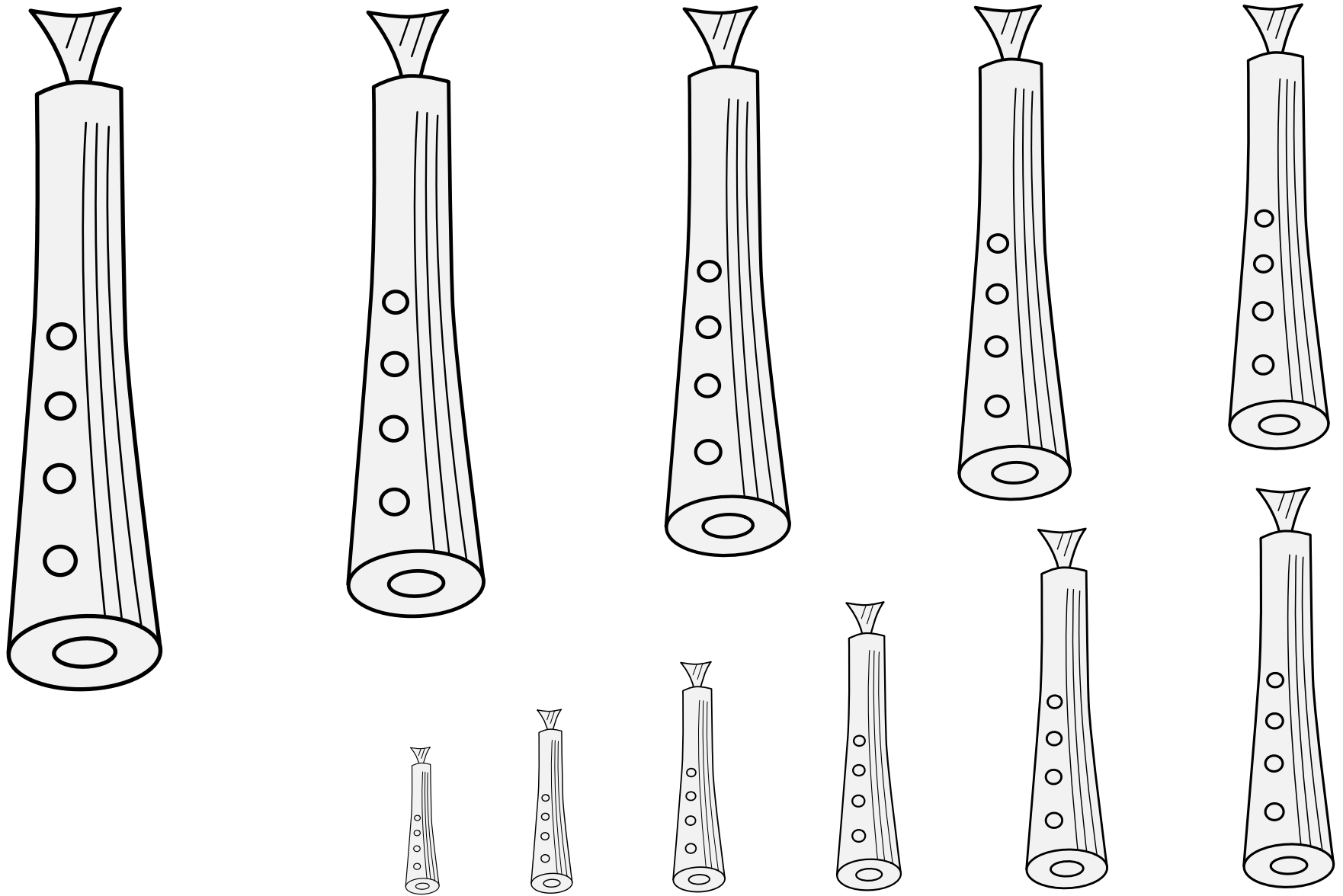

A wind instrument made of wood.

Default orientation: palewise, mouthpiece to chief. Proper coloration: brown wood.

Source: Guillim's Display of Heraldry. Artist unknown. Adapted by Mathghamhain Ua Ruadháin.

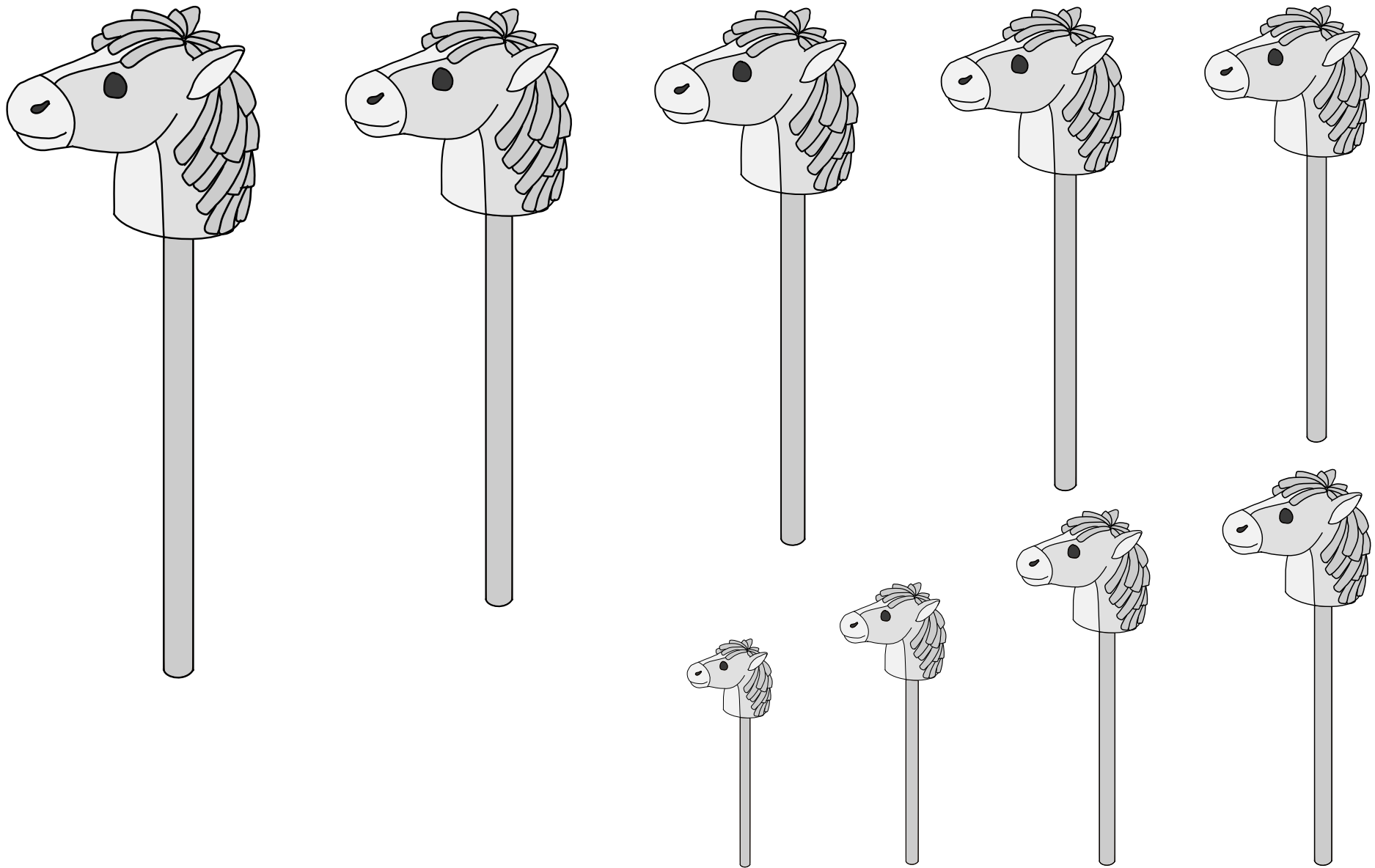

A toy horse's head mounted on a stick, used as a toy.
Default orientation: head to chief, facing dexter. No proper coloration.
Artist: Wylet Fraser.

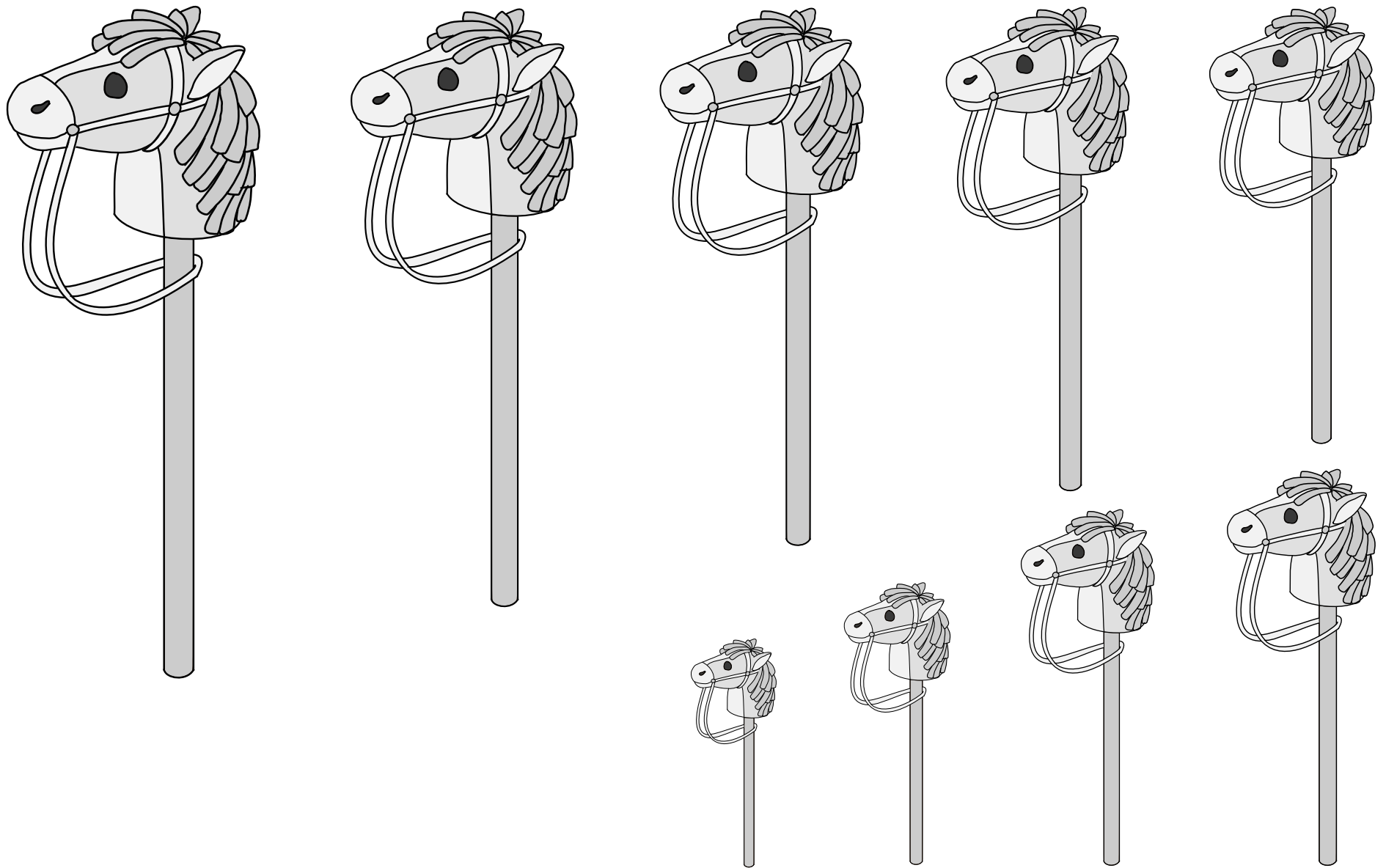

A toy horse's head mounted on a stick, used as a toy.
Default orientation: head to chief, facing dexter. No proper coloration.
Artist: Wylet Fraser.

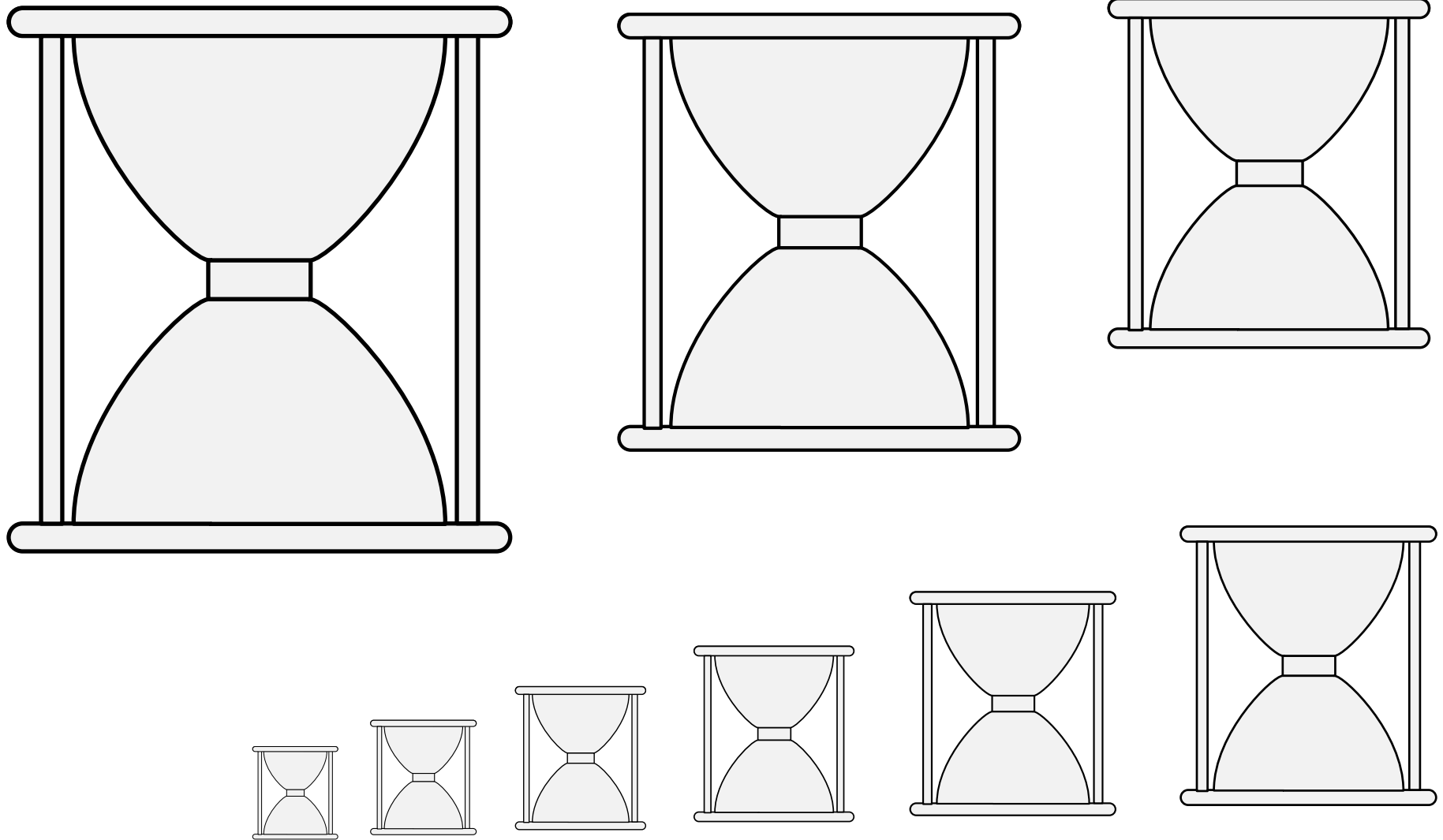

A mechanism for measuring the passage of time.

Default orientation: palewise. No proper coloration.

Source: Pennsic Traceable Art. Artist unknown. Adapted by Mathghamhain Ua Ruadháin.

Hourglass (1) 18.109

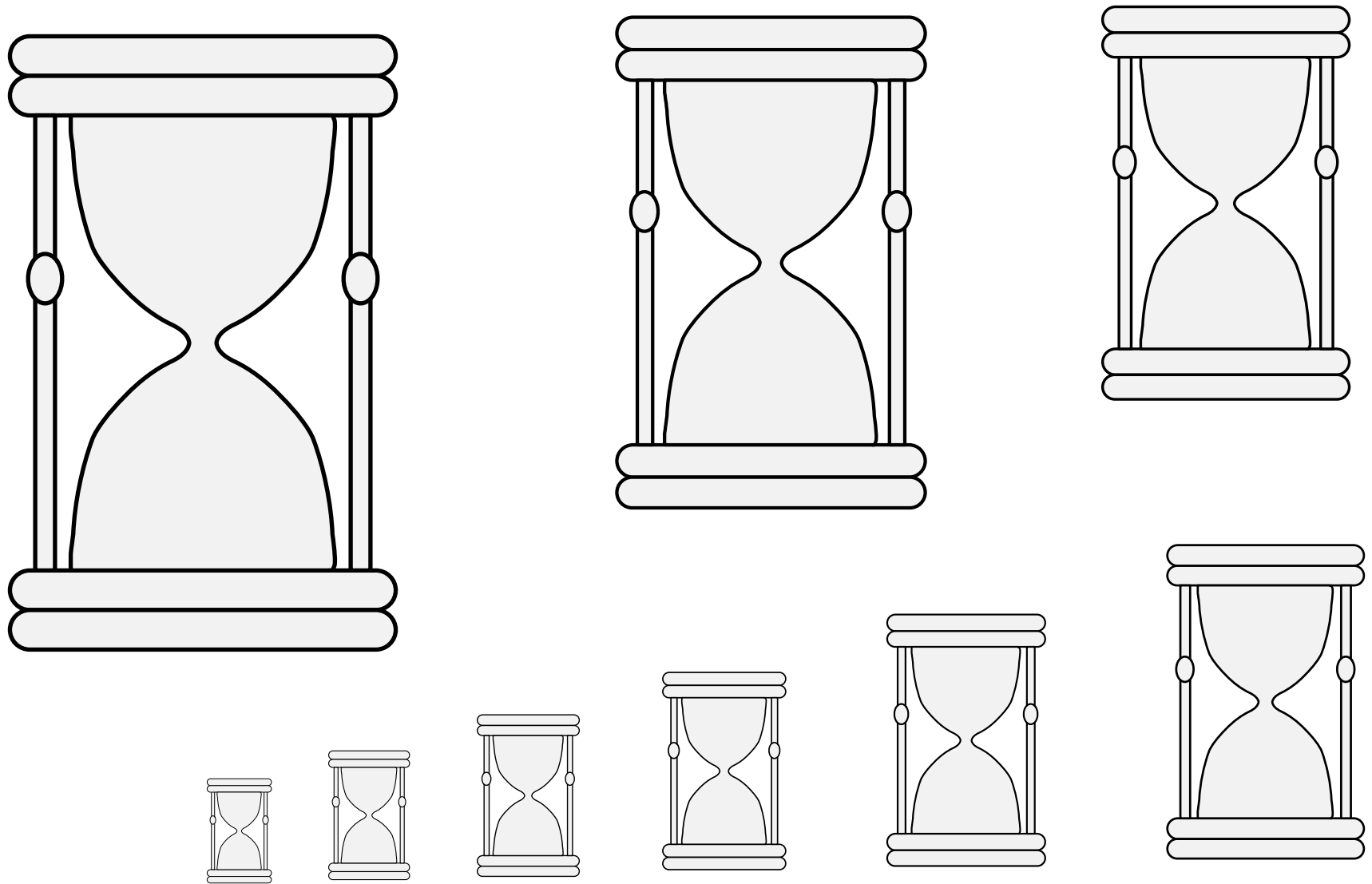

A mechanism for measuring the passage of time.
Default orientation: palewise. No proper coloration.

Source: Pennsic Traceable Art. Artist unknown. Adapted by Mathghamhain Ua Ruadháin.

Hourglass (2) 18.110

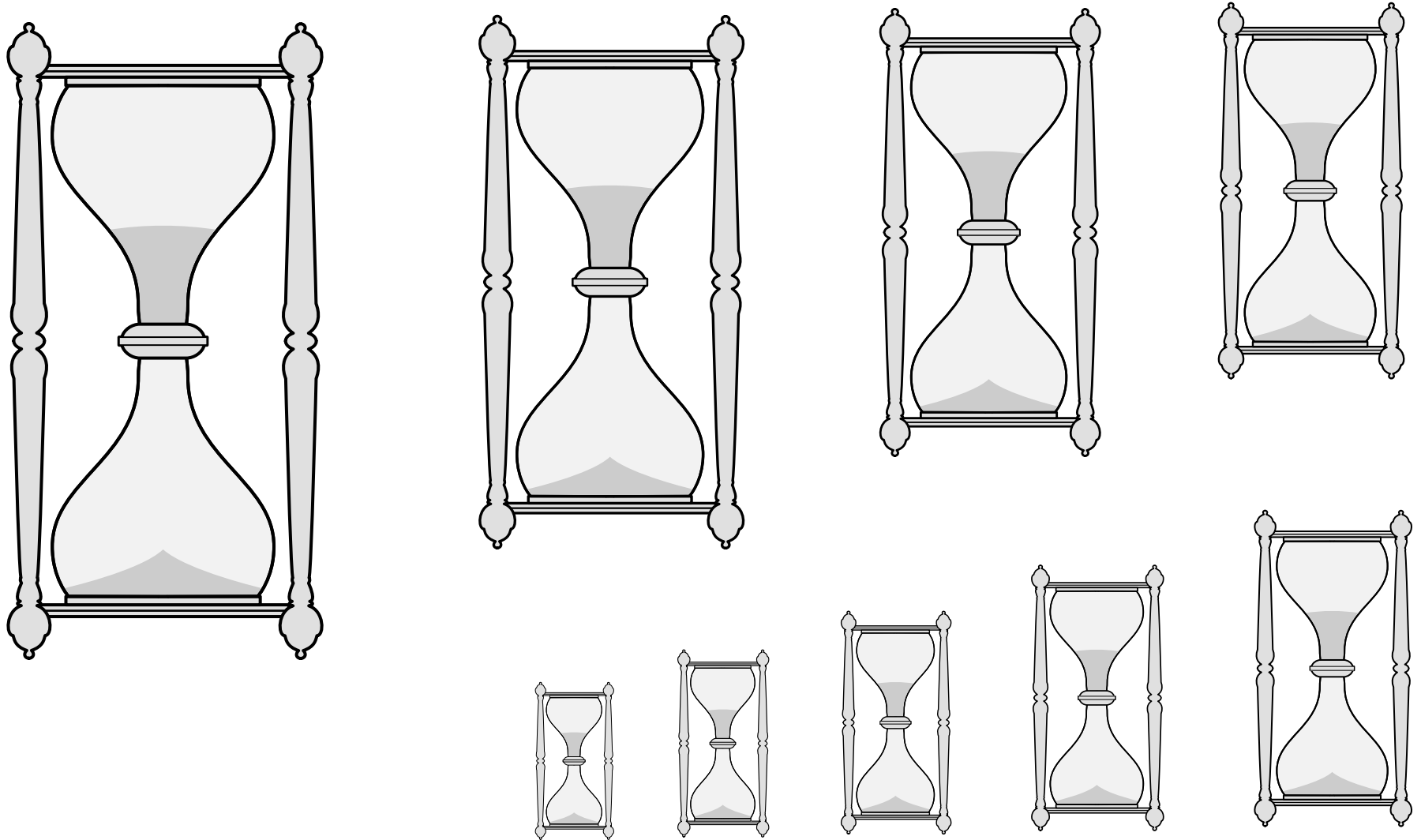

A mechanism for measuring the passage of time.

Default orientation: palewise. No proper coloration.

Source: L'Ancienne France. Artist unknown. (Page 123.)

Hourglass (3) 18.111

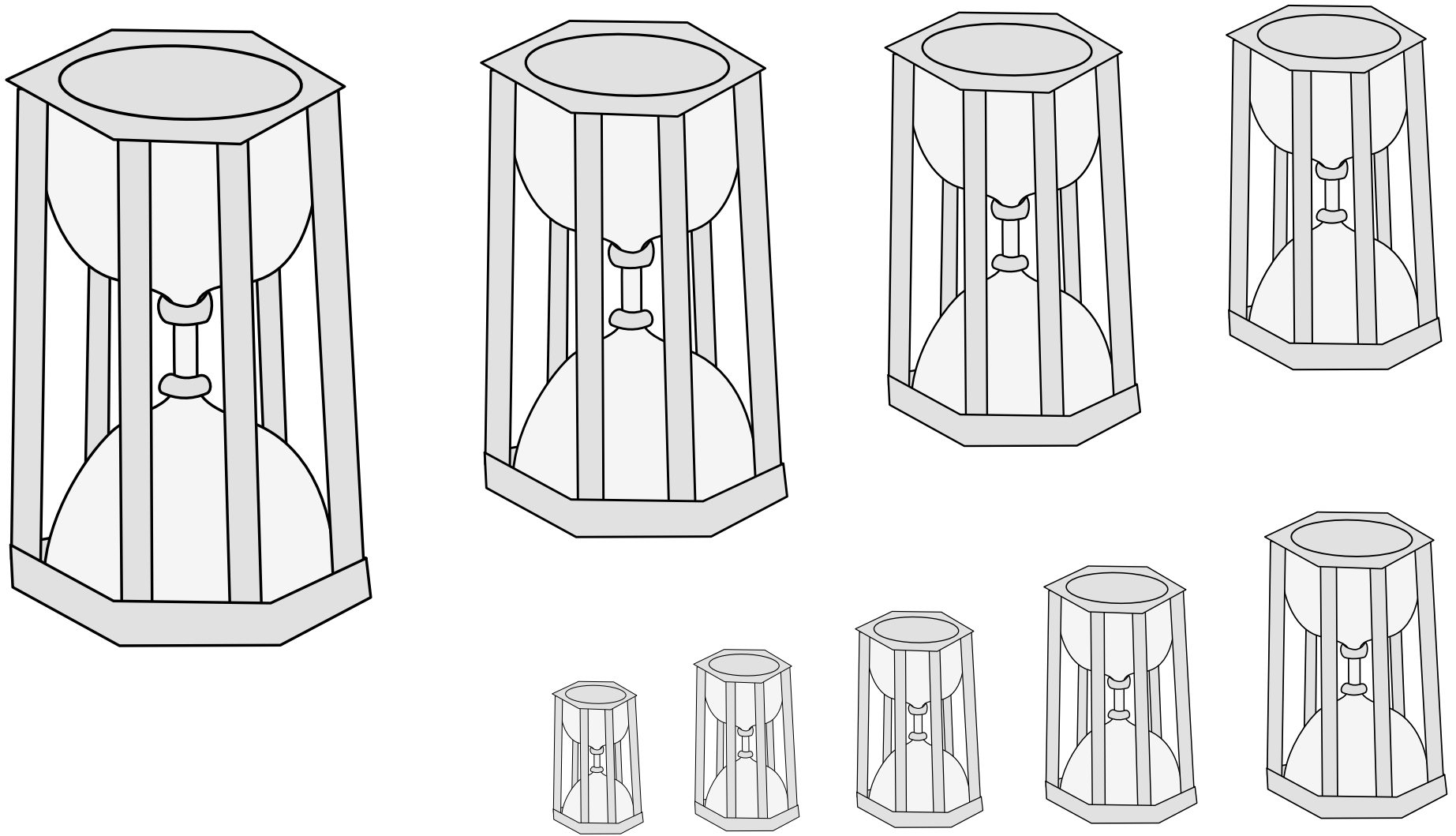

A mechanism for measuring the passage of time.
Default orientation: palewise. No proper coloration.
Source: Chorographia Württemberg. (Folio 33r.)
Artist unknown. Adapted by Iago ab Adam.

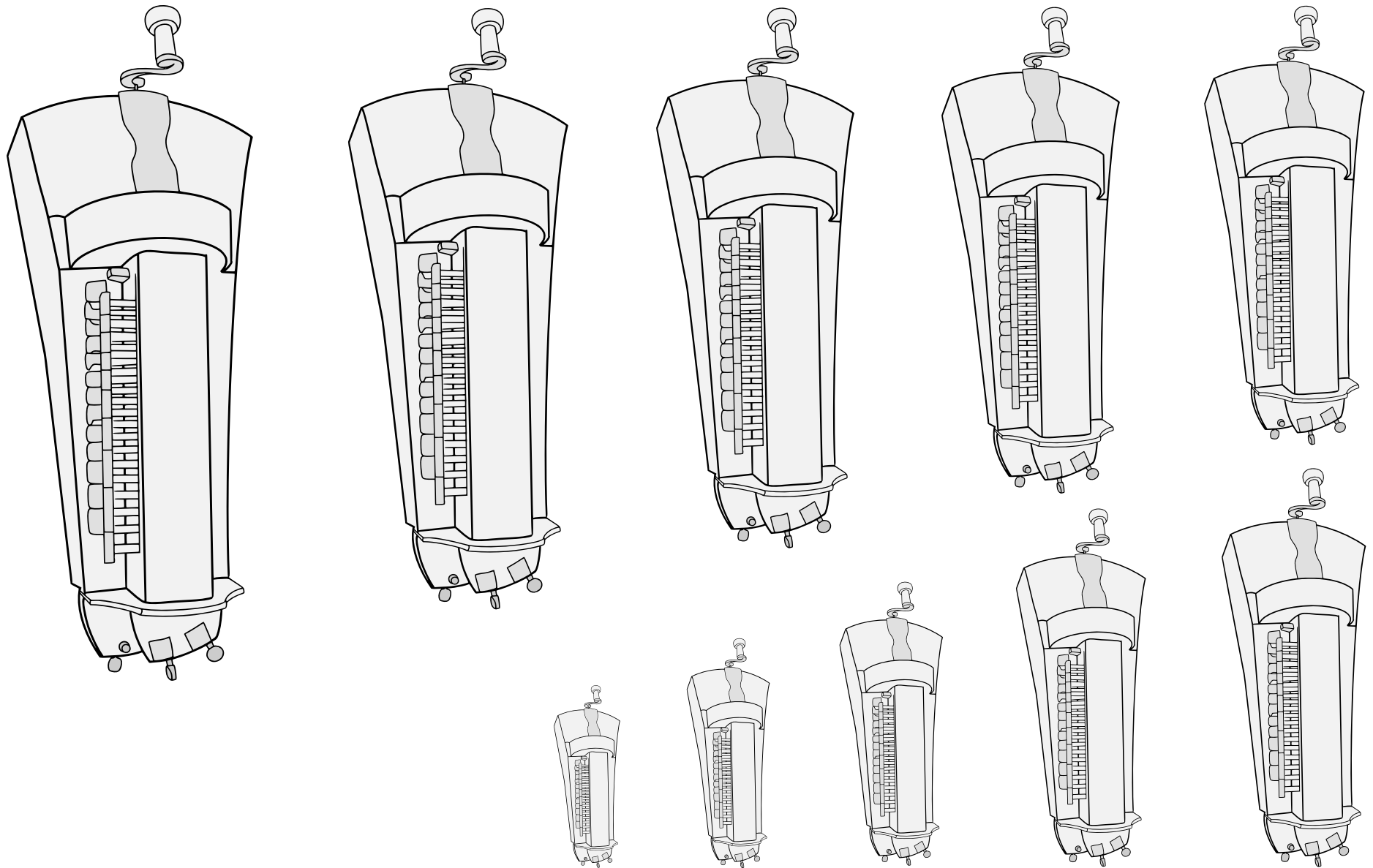

A musical instrument played with a combination of a keyboard and a crank.

No default orientation. No proper coloration.

Artist: Tali Essen of the Isles.

Hurdy-Gurdy 18.113

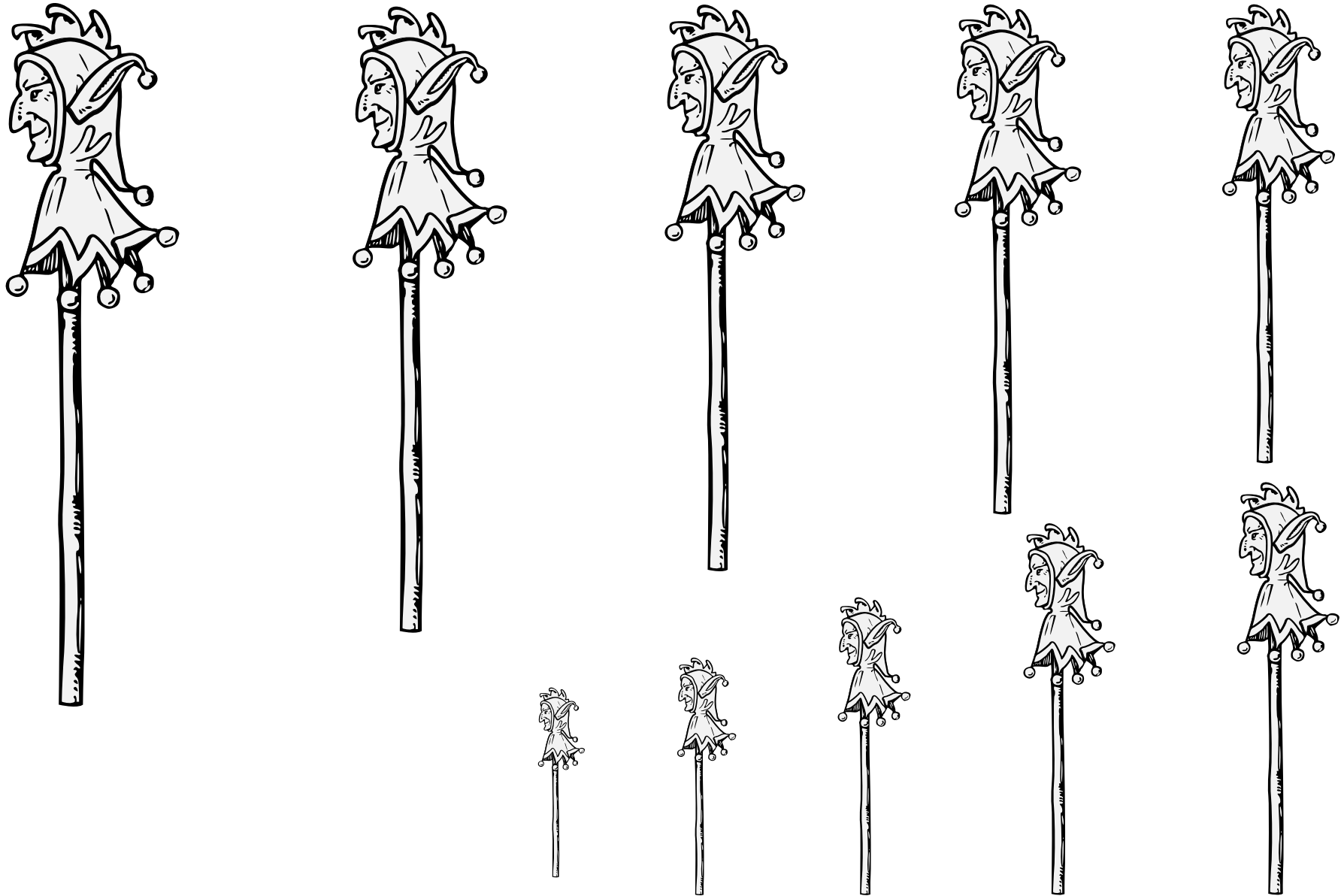

A staff topped with a fool's head, used as a puppet or foil in a jester's entertainment.

Default orientation: head to chief. Proper coloration: brown wood, argent or pink face, explicitly-blazoned vestments.

Source: The Principles of Design. Artist: George Woolliscroft-Rhead.

Jester's Bauble 18.114

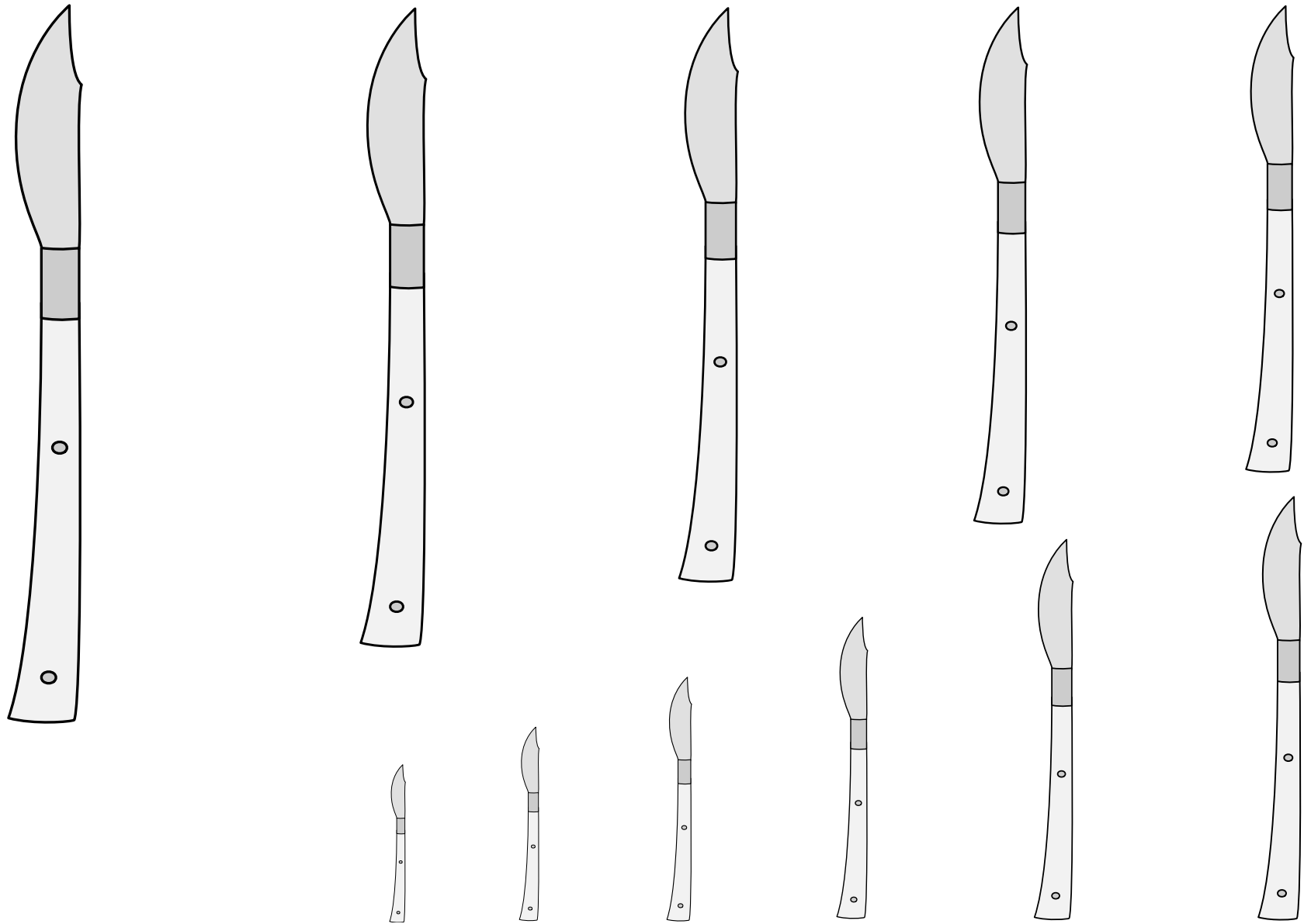

A small knife used to trim quills and scrape parchment.
Default orientation: blade to chief. No proper coloration.
Artist: Mathghamhain Ua Ruadháin.

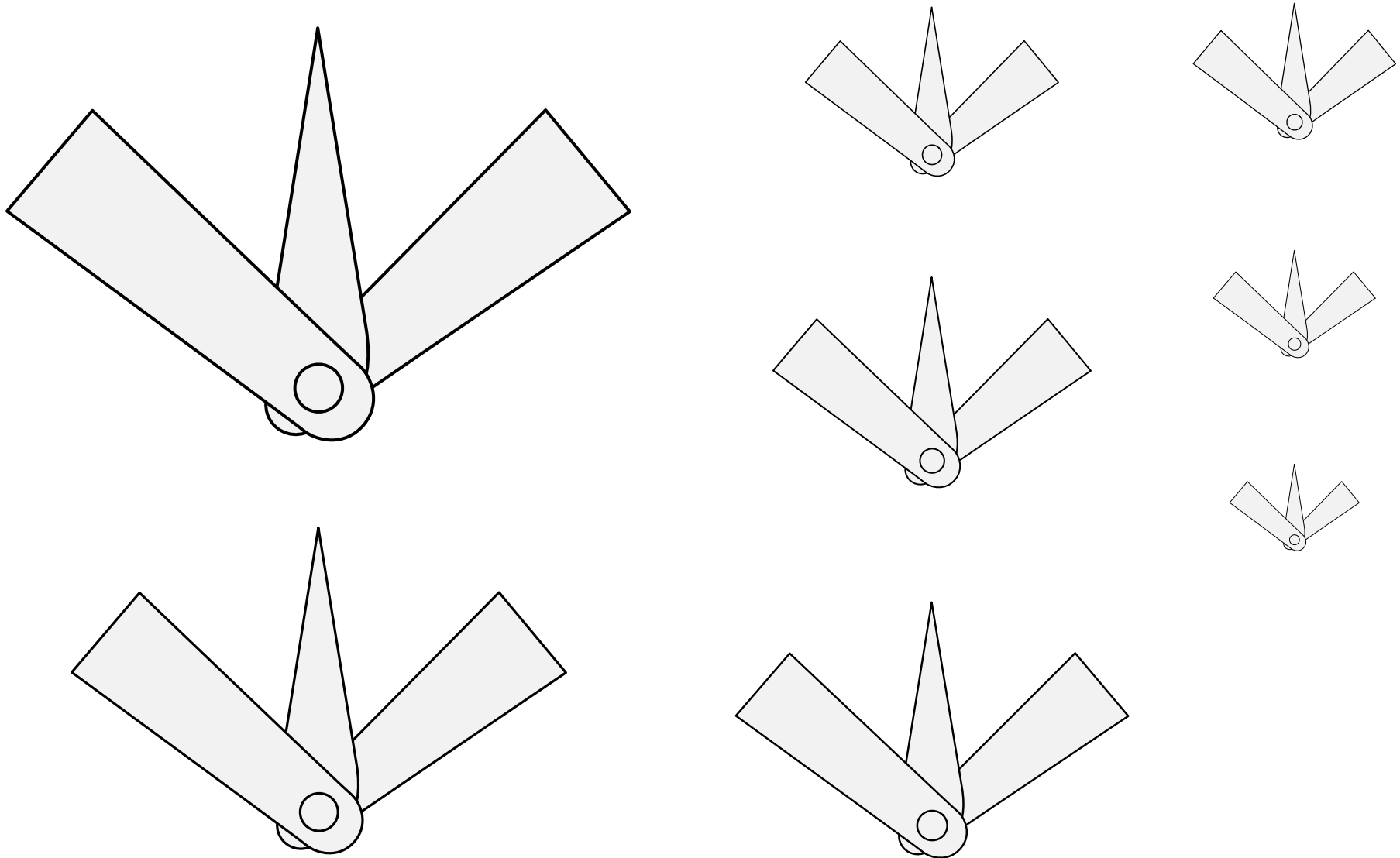

A bloodletting tool, with a sharp double-edged blade and protective flaps that rotate to cover or expose the point.

Default orientation: point to chief. No proper coloration.

Source: Armorial Général de France. Artist unknown. (Arms of the Cutlers of Paris.)

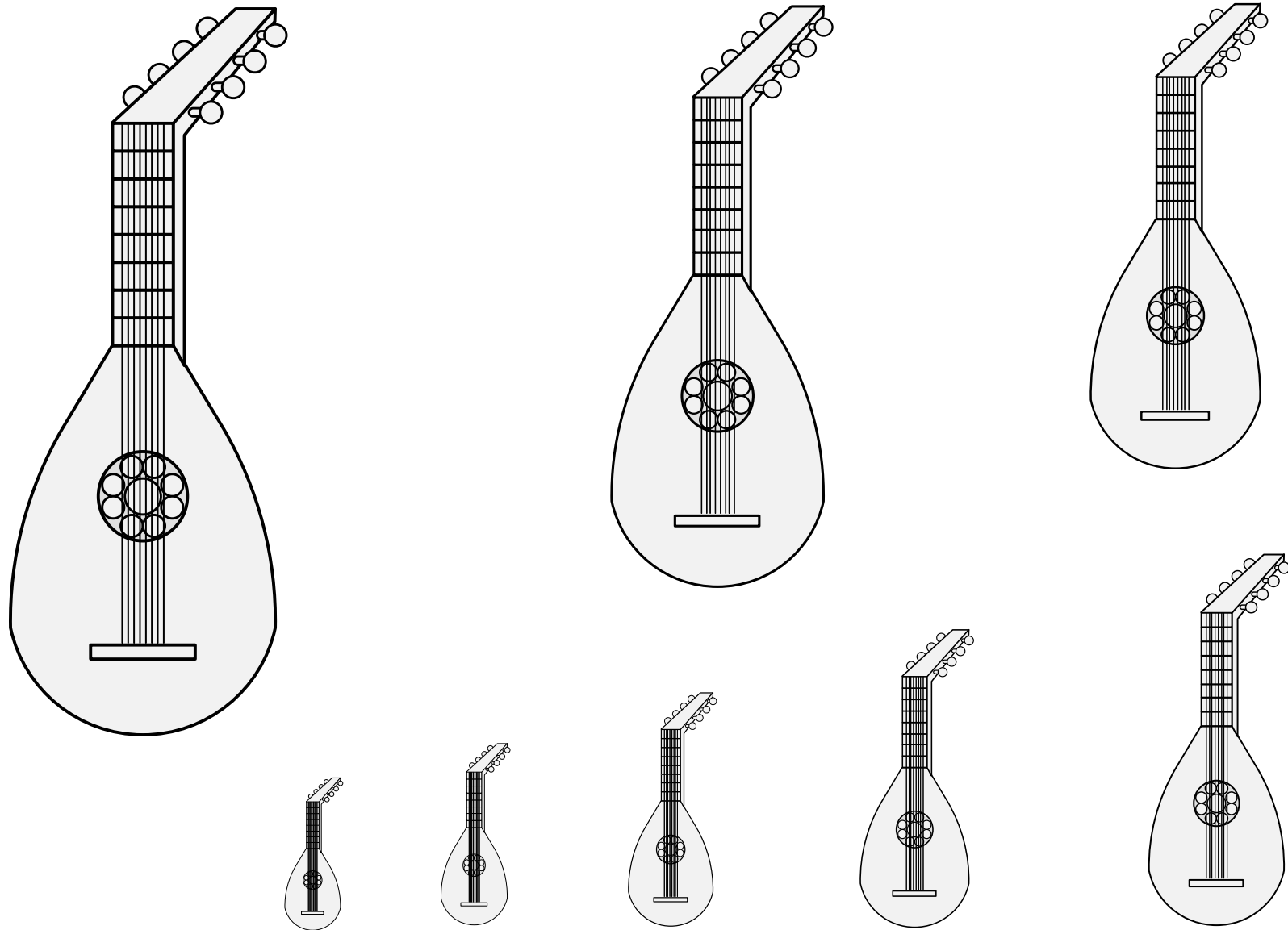

A round-backed string instrument.

Default orientation: neck to chief. No proper coloration.

Source: Viking Answer Lady SVG Images For Heraldists. Artist: Gunnvôr silfráhr.

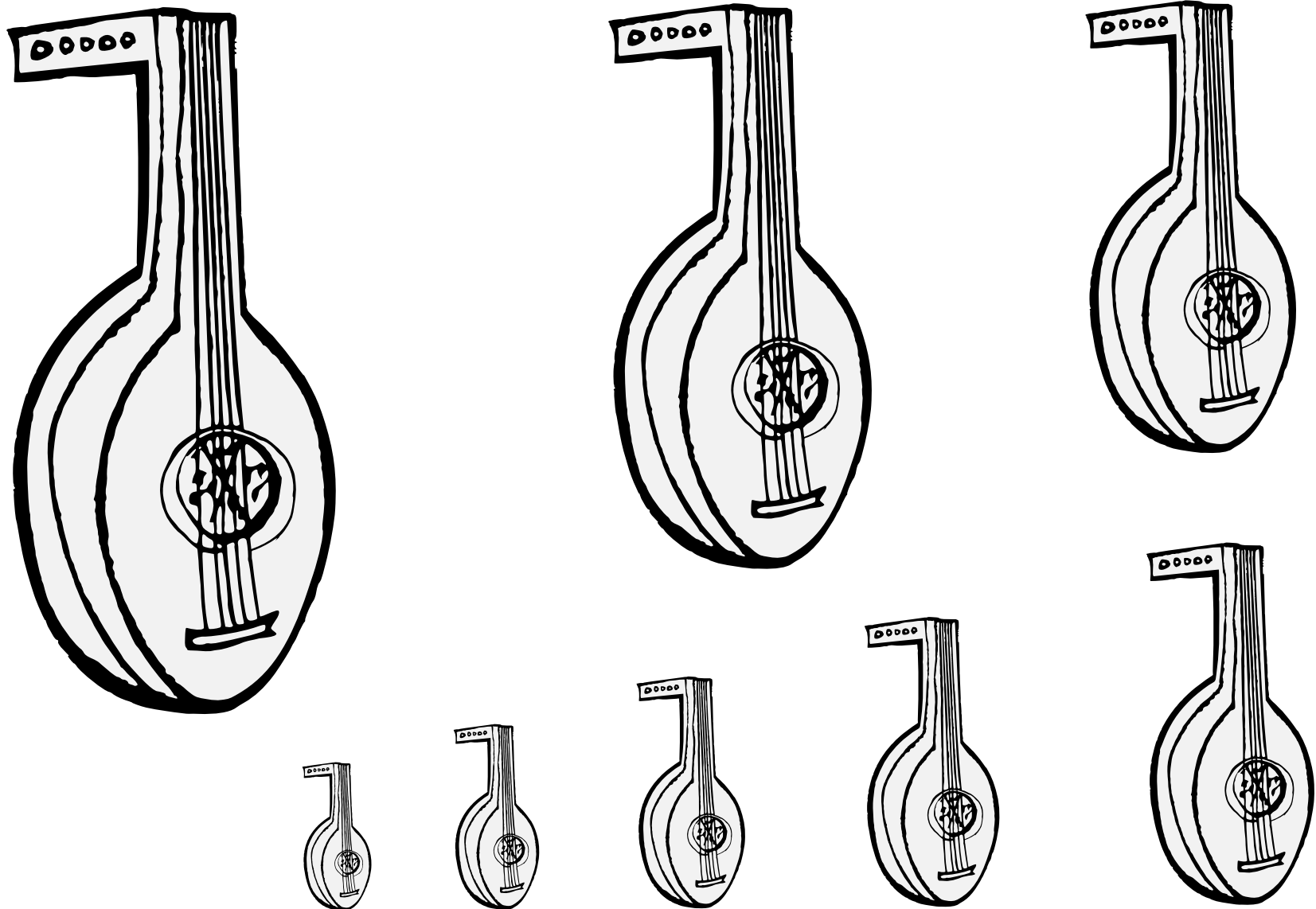

A round-backed string instrument.

Default orientation: neck to chief. No proper coloration.

Source: Hungarian National Archives. Artist unknown.
(Arms of Sebestyén Tinódi, granted 1553.08.25.)

Lute (2) 18.118

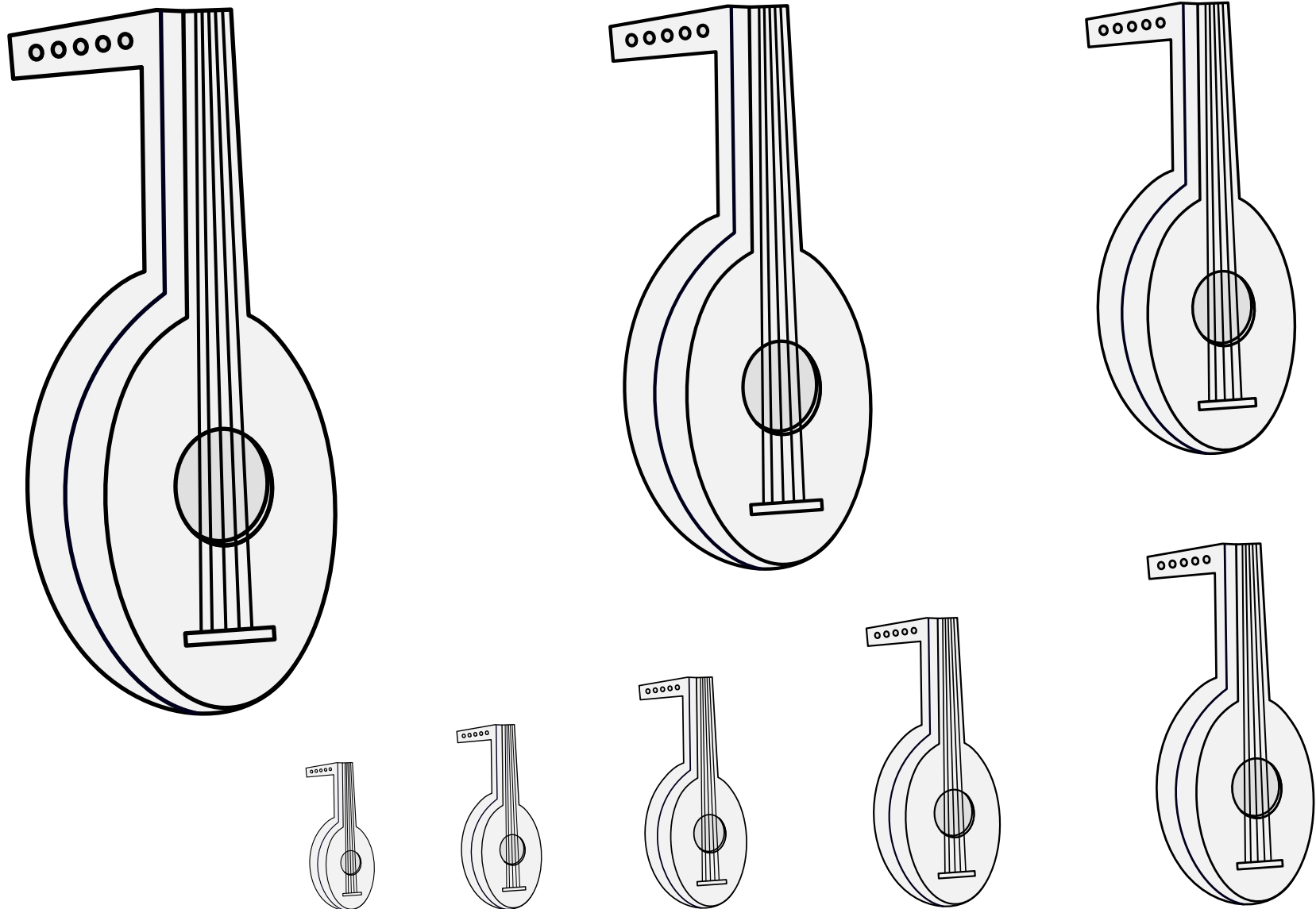

A round-backed string instrument.

Default orientation: neck to chief. No proper coloration.

Source: Hungarian National Archives. Artist unknown.
(Arms of Sebestyén Tinódi, granted 1553.08.25.)

Adapted by Mathghamhain Ua Ruadháin.

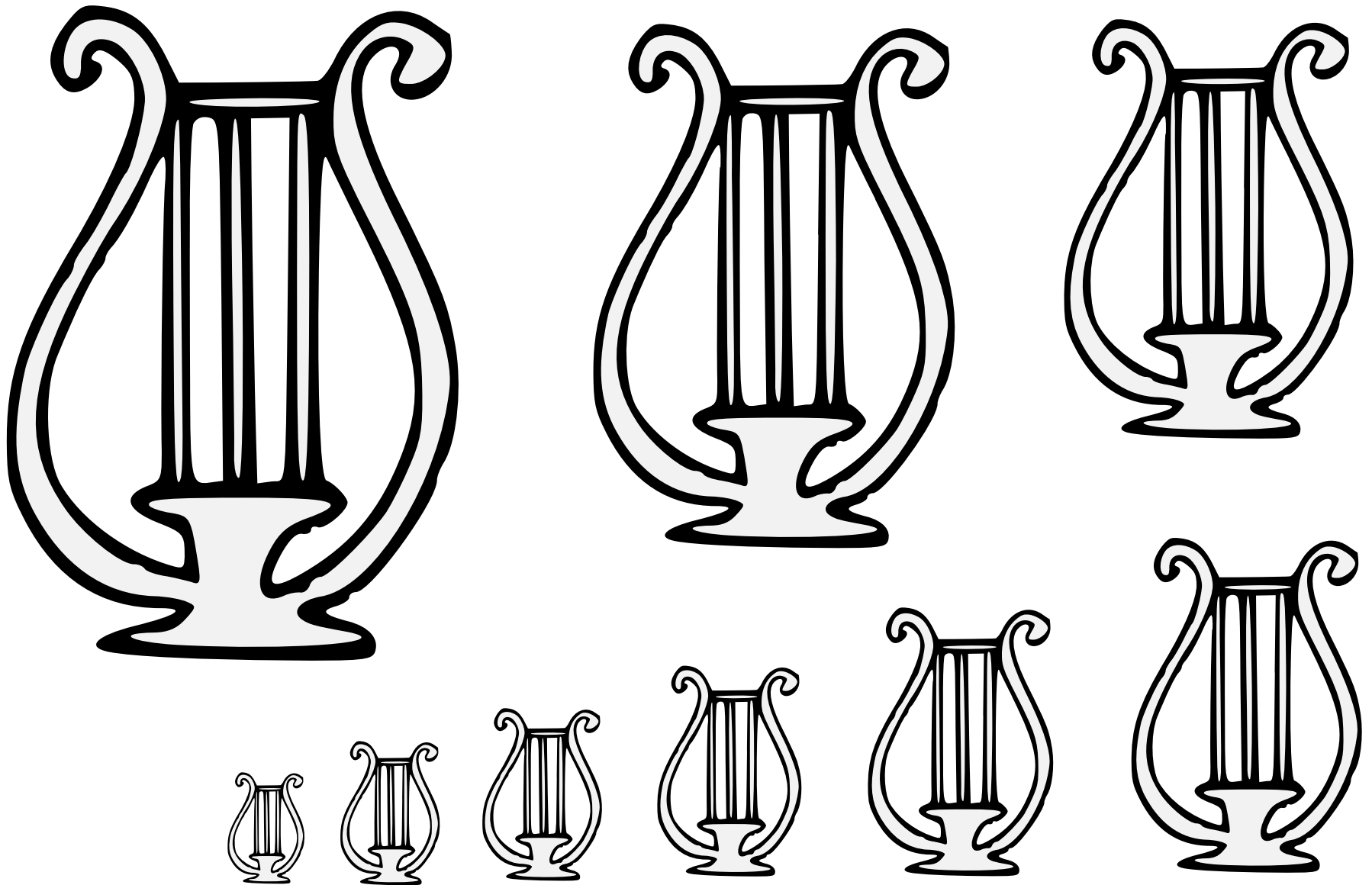

A string instrument.

Default orientation: upright. No proper coloration.

Source: Pennsic Traceable Art. Artist: Roana d'Evreux.

Lyre (1) 18.120

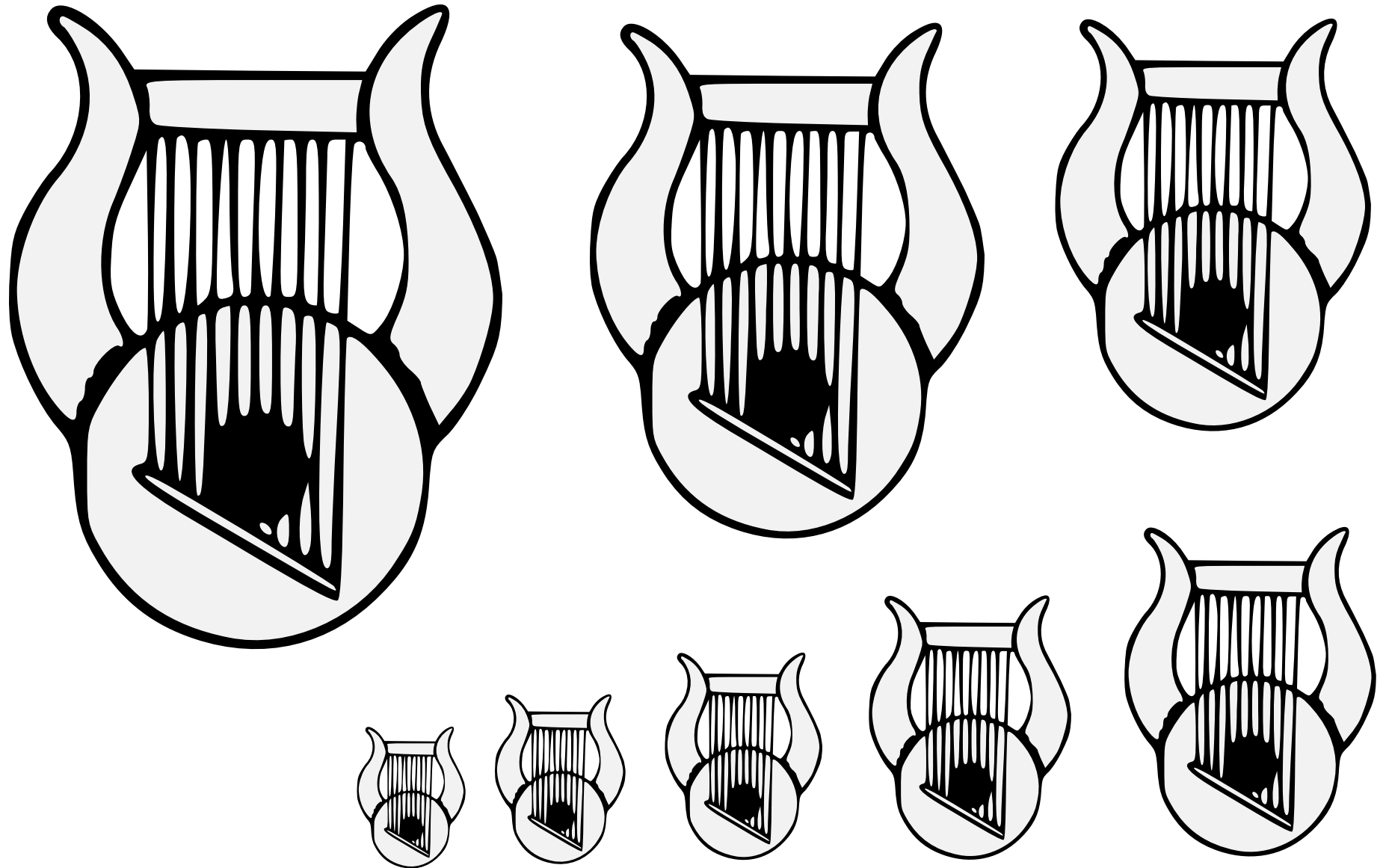

A string instrument.

Default orientation: upright. No proper coloration.

Source: Pennsic Traceable Art. Artist: Unknown.

Lyre (2) 18.121

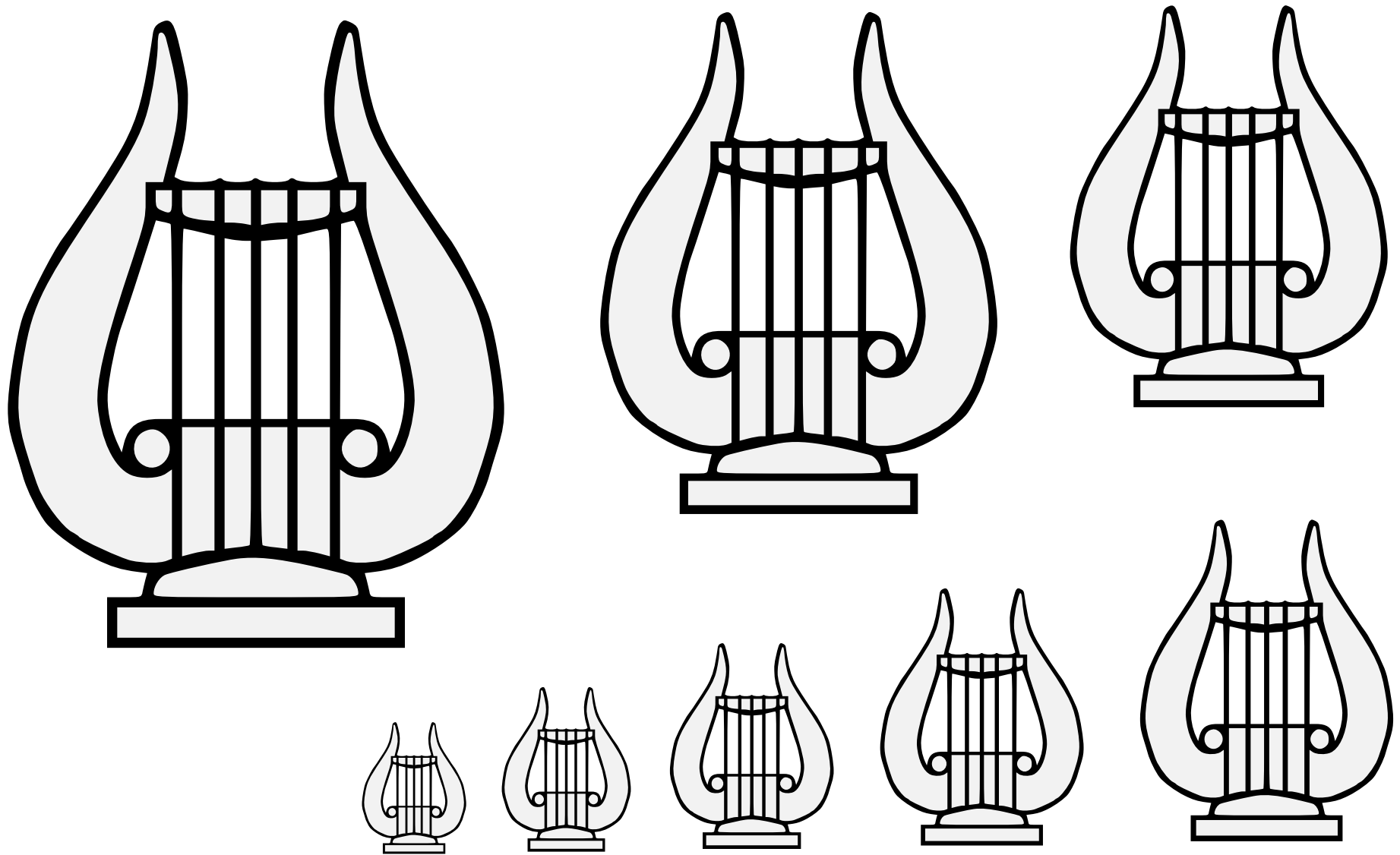

A string instrument.

Default orientation: upright. No proper coloration.

Artist: Jessimond of Emerickeskepe.

Lyre (3) 18.122

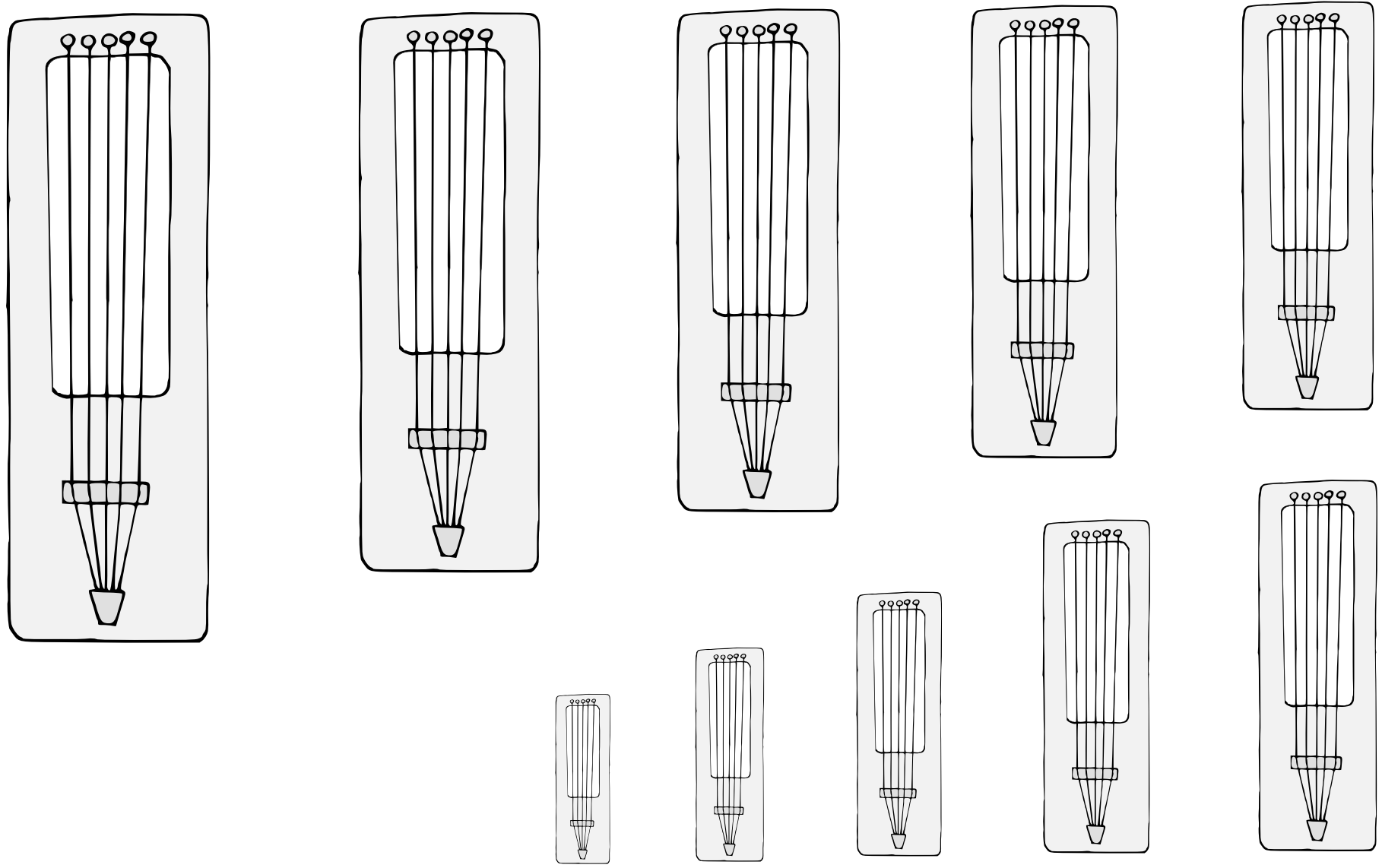

A string instrument.
Default orientation: upright. No proper coloration.
Artist: Elspeth Farre.

Lyre (4) 18.123

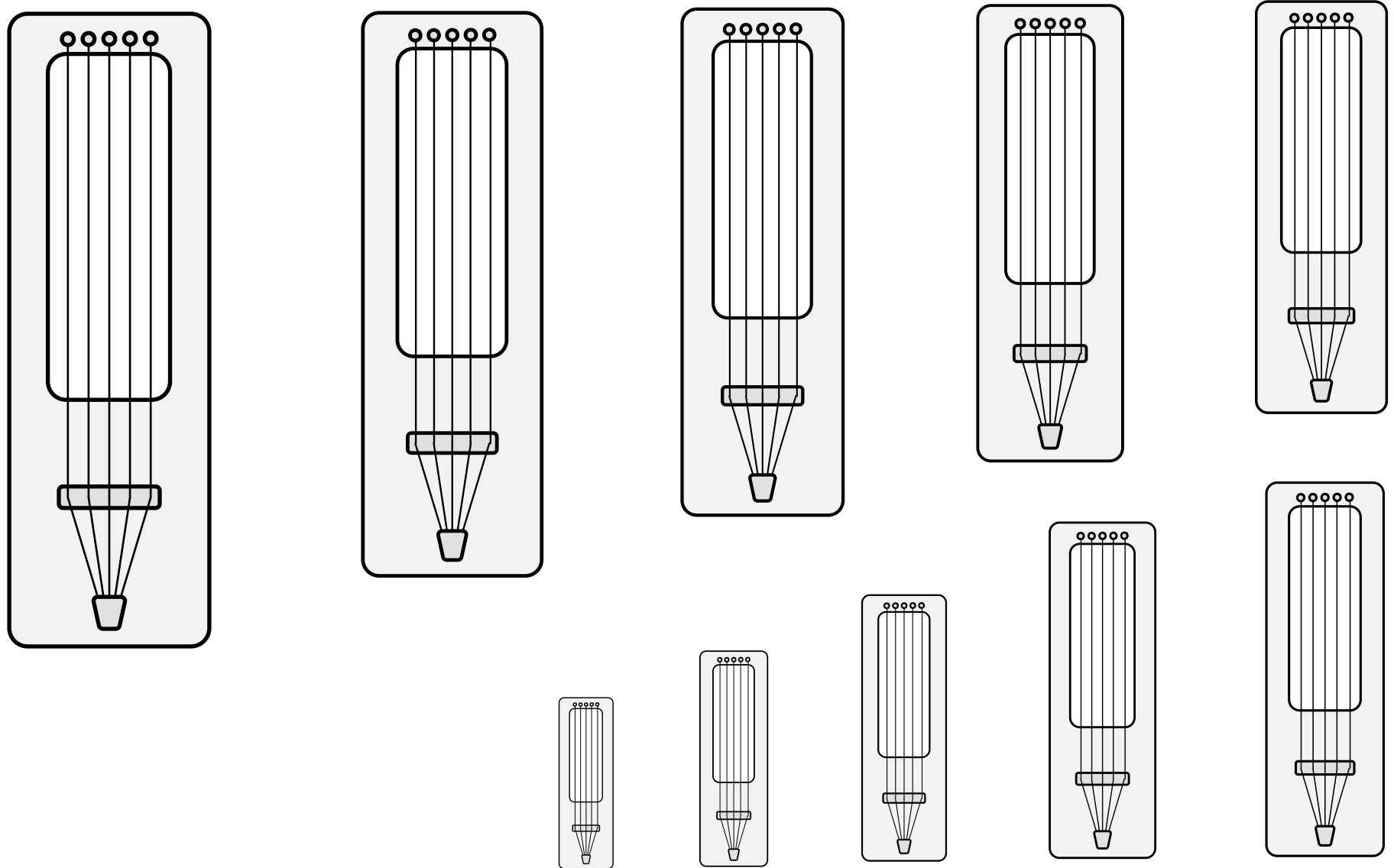

A string instrument.

Default orientation: upright. No proper coloration.

Artist: Elspeth Farre. Adapted by Mathghamhain Ua Ruadháin.

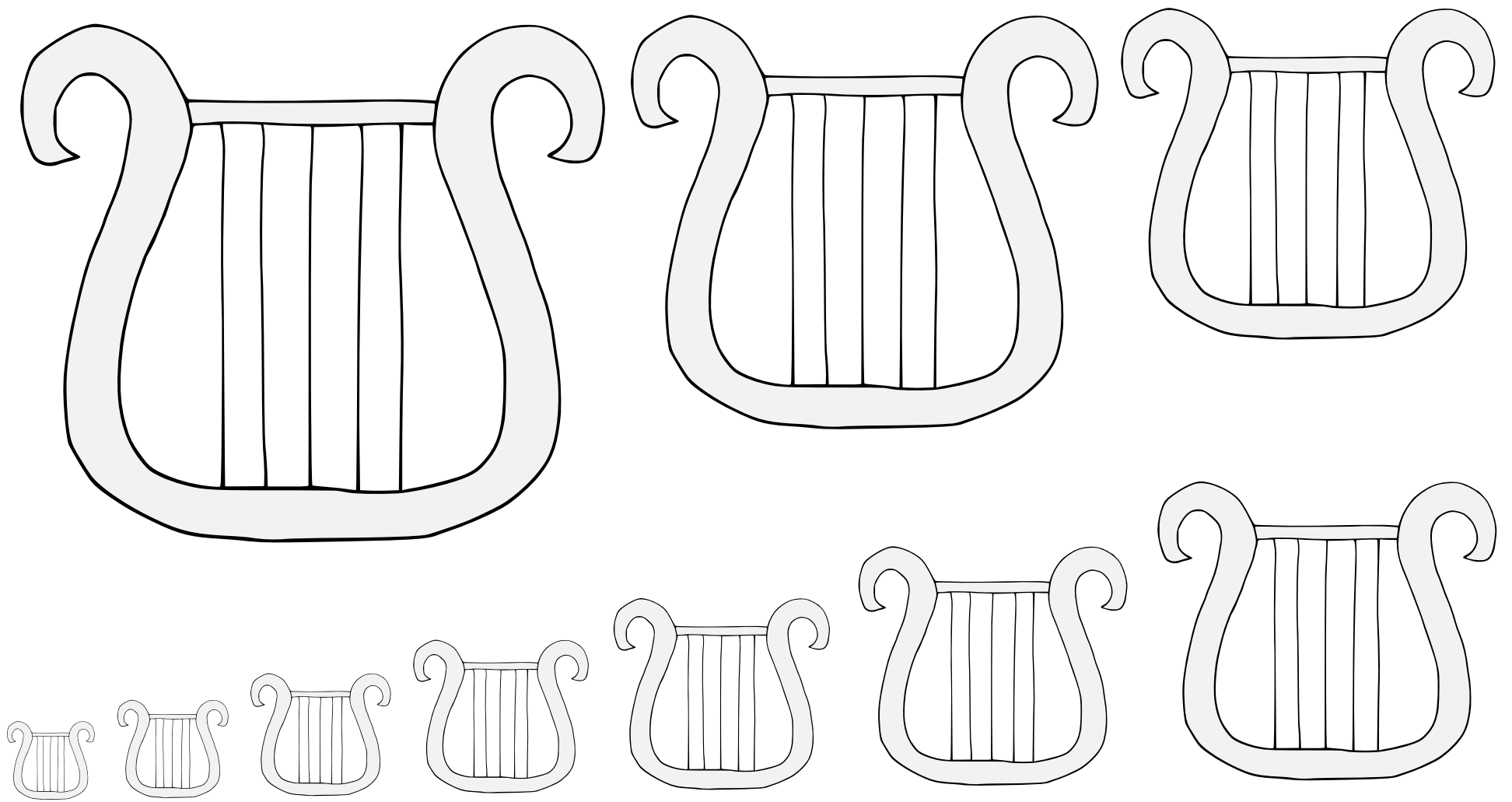

A string instrument.

Default orientation: upright. No proper coloration.

Artist: Elspeth Farre.

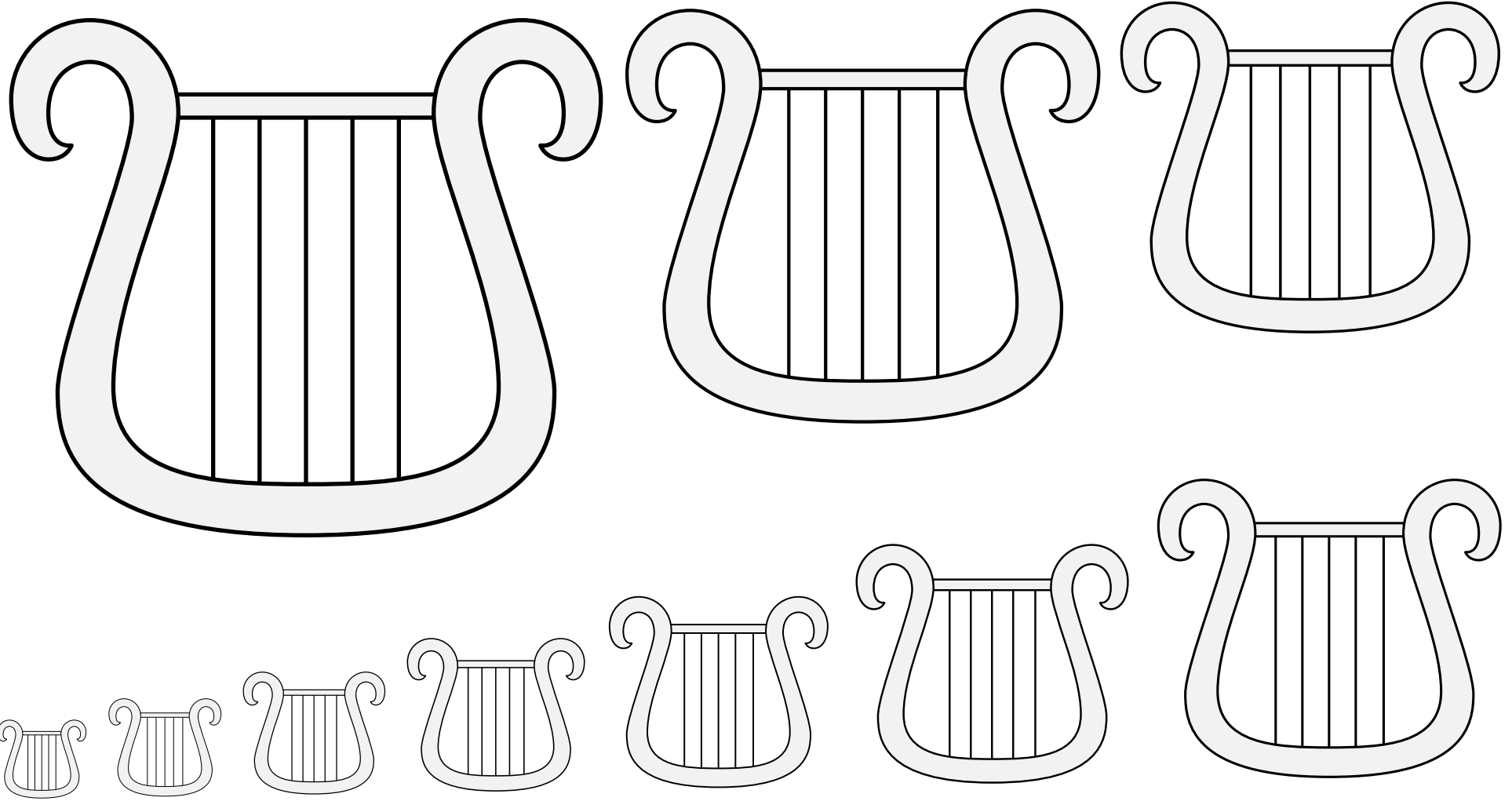

A string instrument.

Default orientation: upright. No proper coloration.

Artist: Elspeth Farre. Adapted by Mathghamhain Ua Ruadháin.

Lyre (7) 18.126

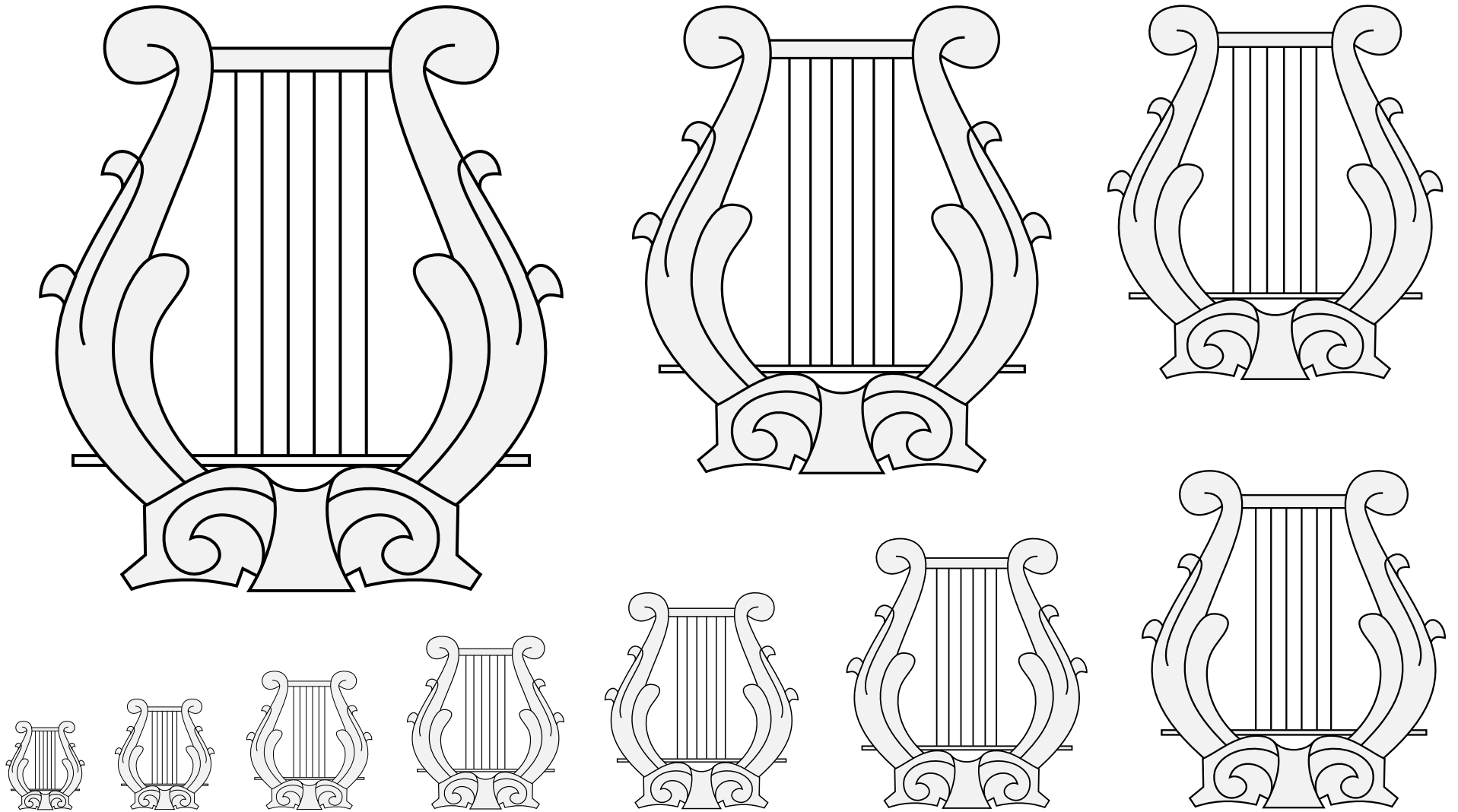

A string instrument.

Default orientation: upright. No proper coloration.

Artist: Gunnvôr silfrahárr.

Lyre (8) • 18.127

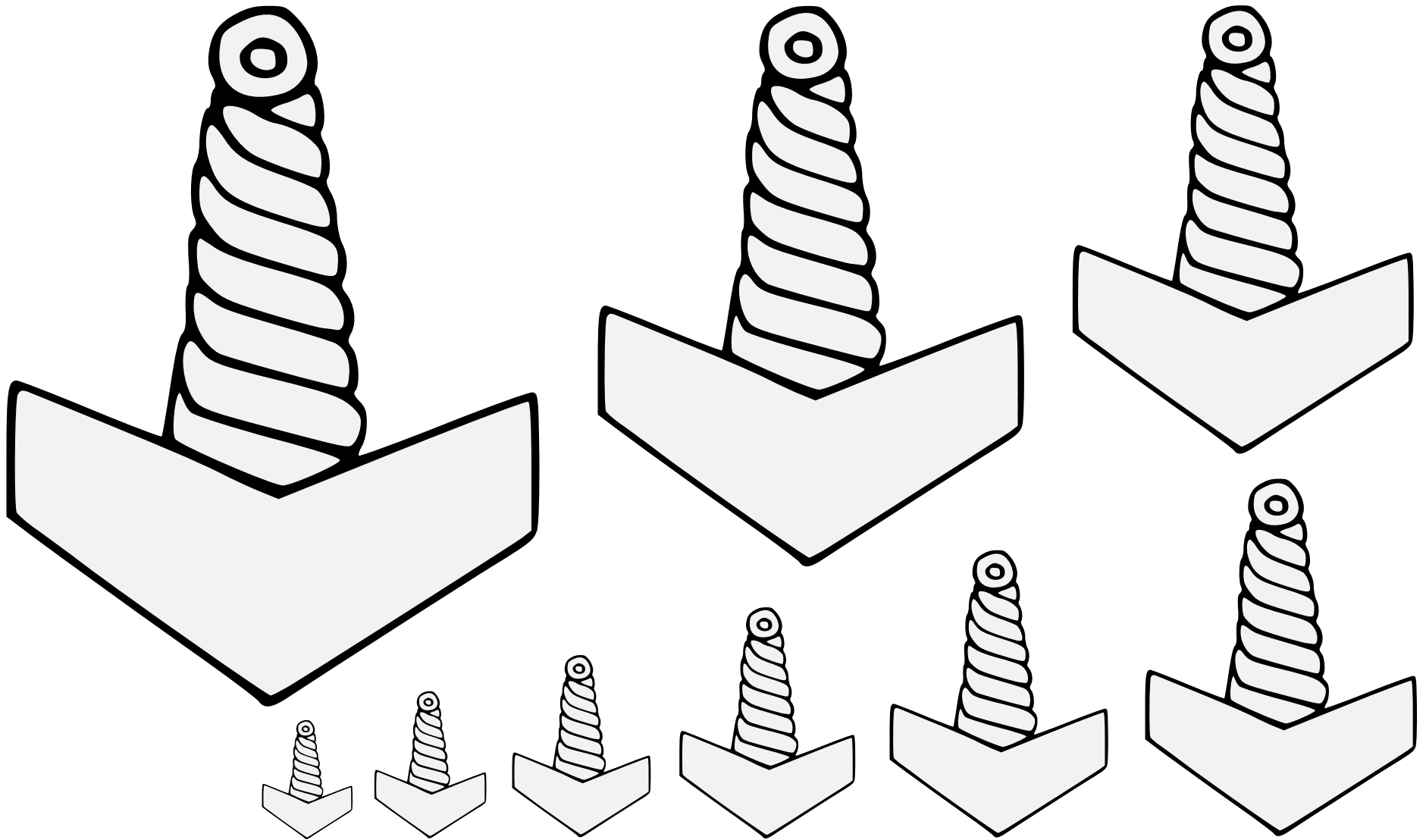

A stylized hammer associated with the Norse thunder god.

Default orientation: head to base. No proper coloration.

Submitters should be aware that this symbol is popular with white supremacists and may prompt additional scrutiny.

Source: Heraldic Templates.

Artist: Torric inn Björn.

Mjolnir or Thor's Hammer (1) 18.128

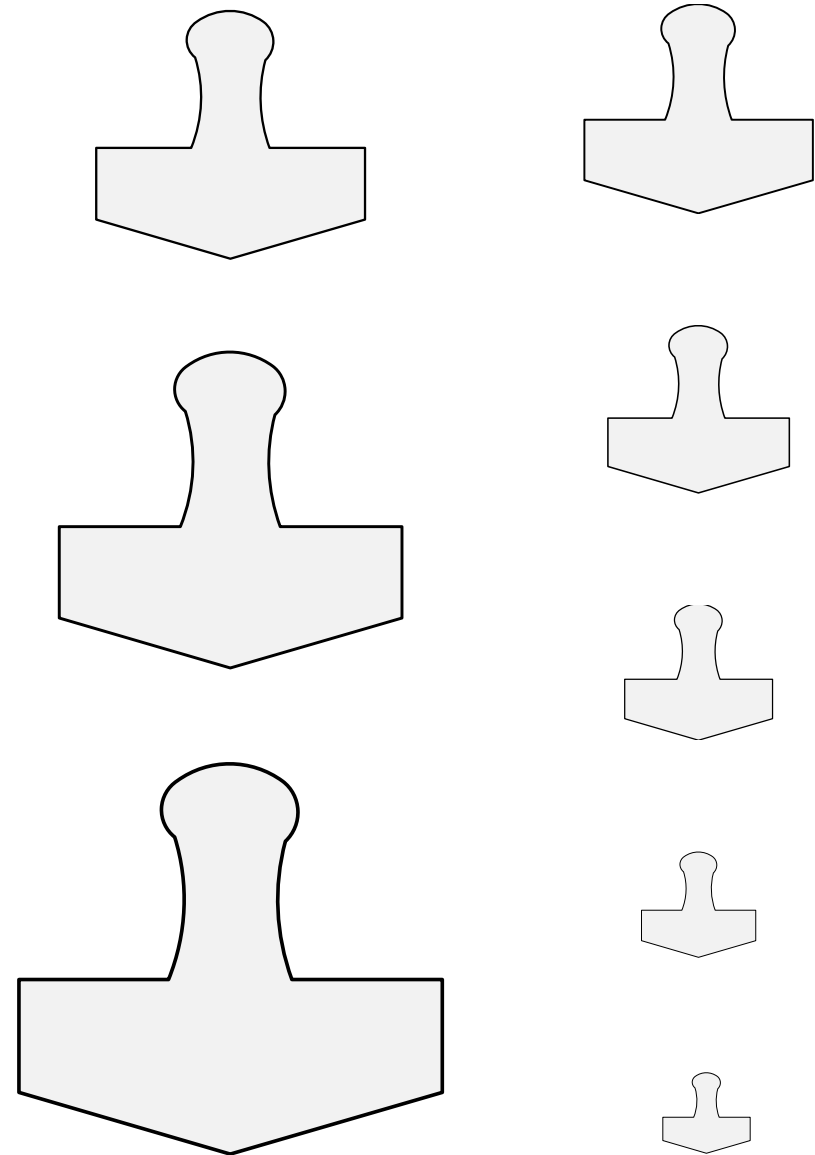
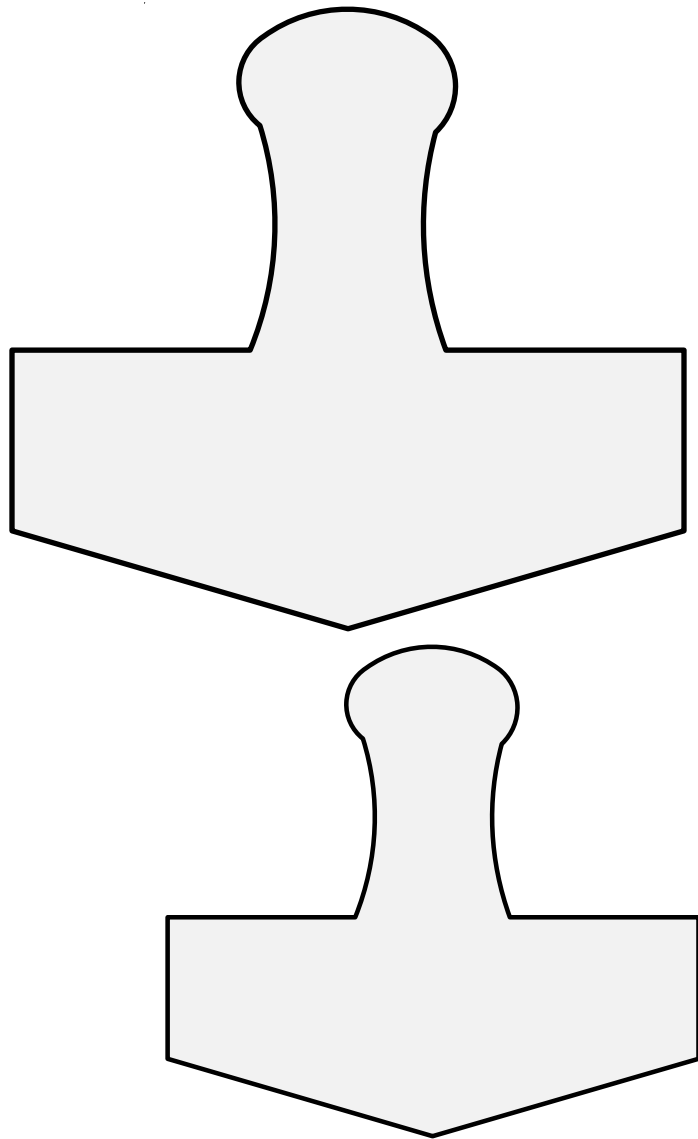

A stylized hammer associated with the Norse thunder god.

Default orientation: head to base. No proper coloration.

Submitters should be aware that this symbol is popular with white supremacists and may prompt additional scrutiny.

Source: Viking Answer Lady SVG Images For
Heralds. Artist: Gunnvôr silfrahárr.

Mjólnir or Thor's Hammer (2) 18.129

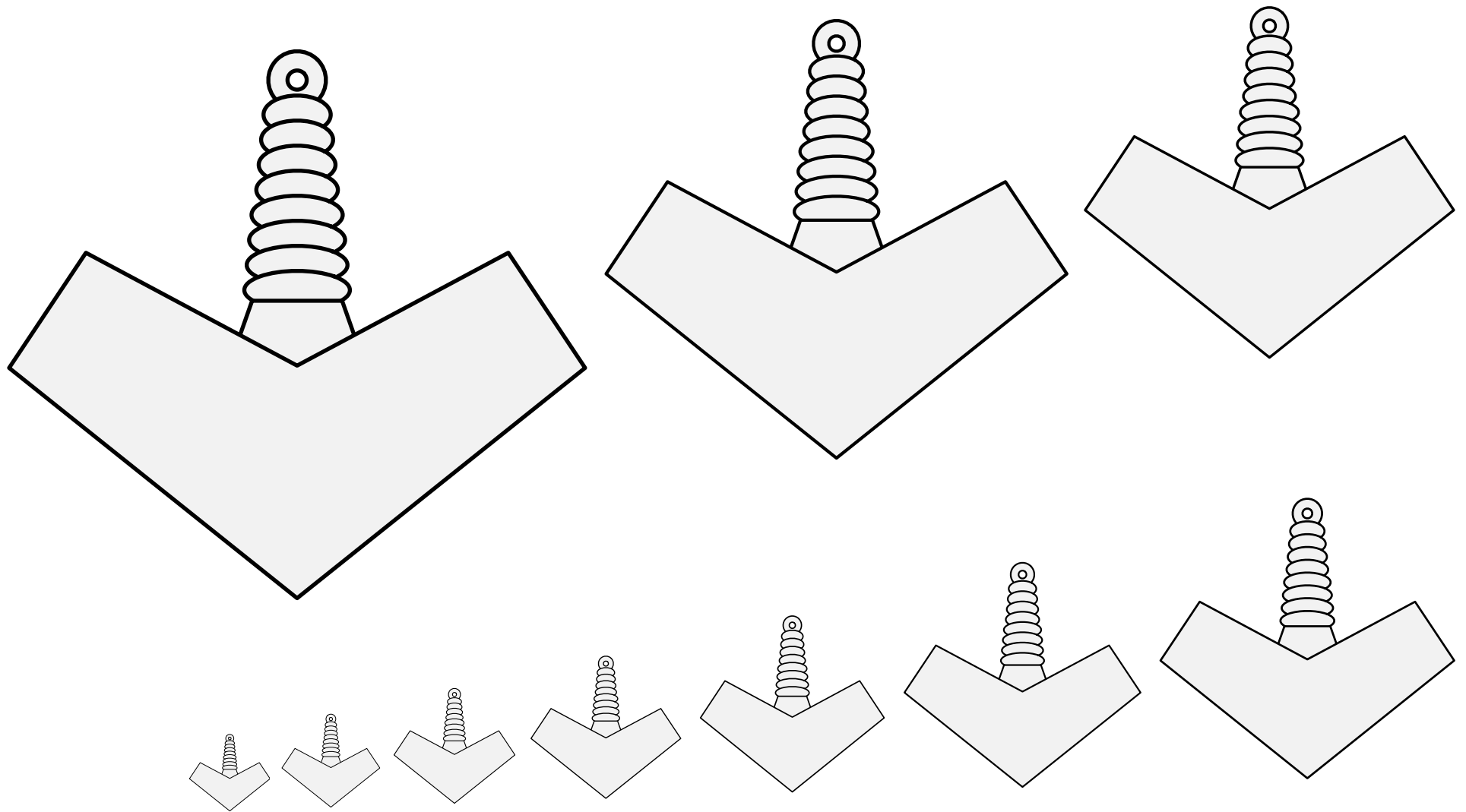

A stylized hammer associated with the Norse thunder god.

Default orientation: head to base. No proper coloration.

Submitters should be aware that this symbol is popular with white supremacists and may prompt additional scrutiny.

Source: Pennsic Traceable Art. Artist: Unknown.

Adapted by Mathghamhain Ua Ruadháin.

Mjolnir or Thor's Hammer (3) 18.130

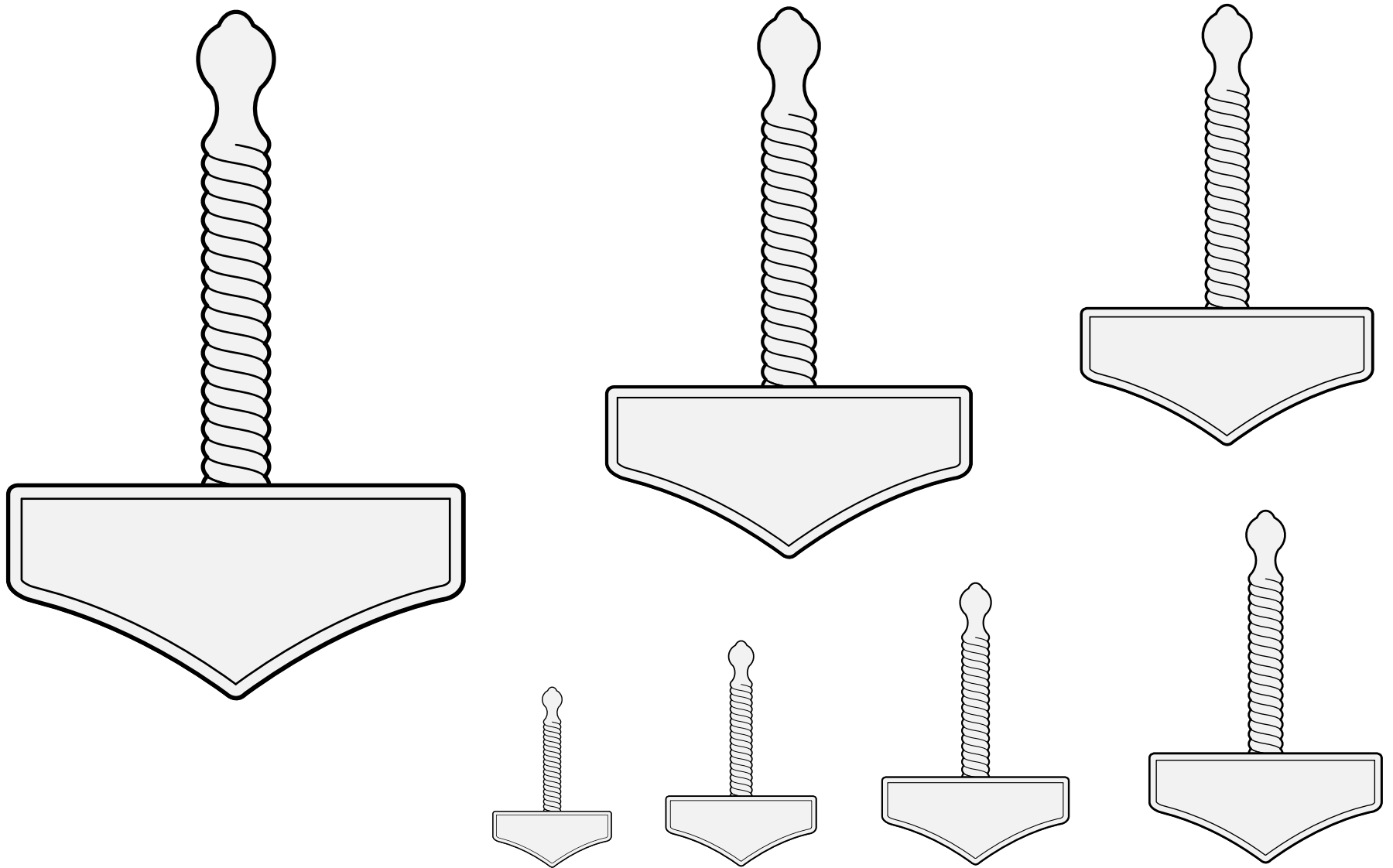

A stylized hammer associated with the Norse thunder god.

Default orientation: head to base. No proper coloration.

Submitters should be aware that this symbol is popular with white supremacists and may prompt additional scrutiny.

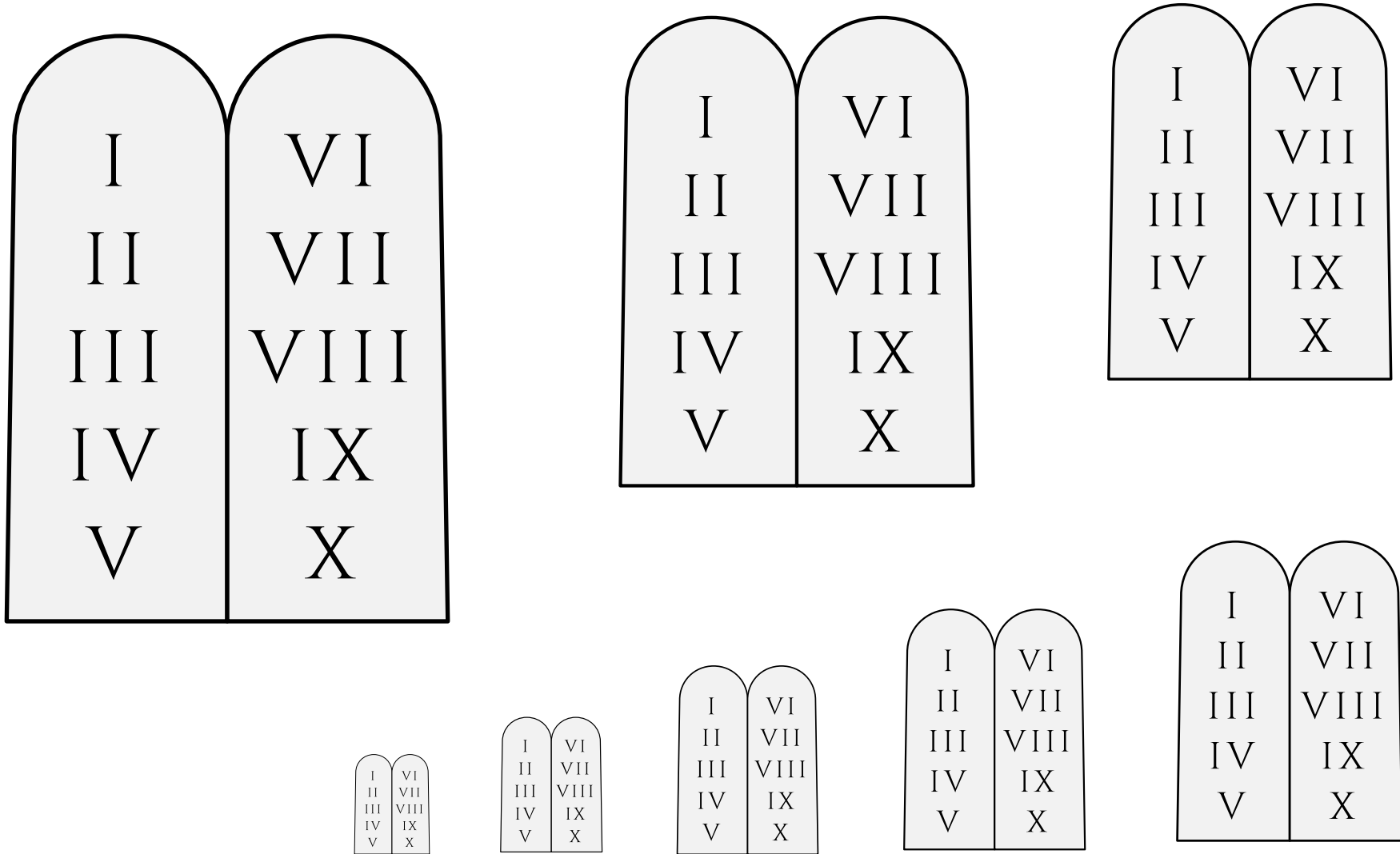

A stone tablet suitable for inscribing important instructions.

Default orientation: upright. No proper coloration.

Adapted from inset tile at the
Cathedral of Saint John the Divine.

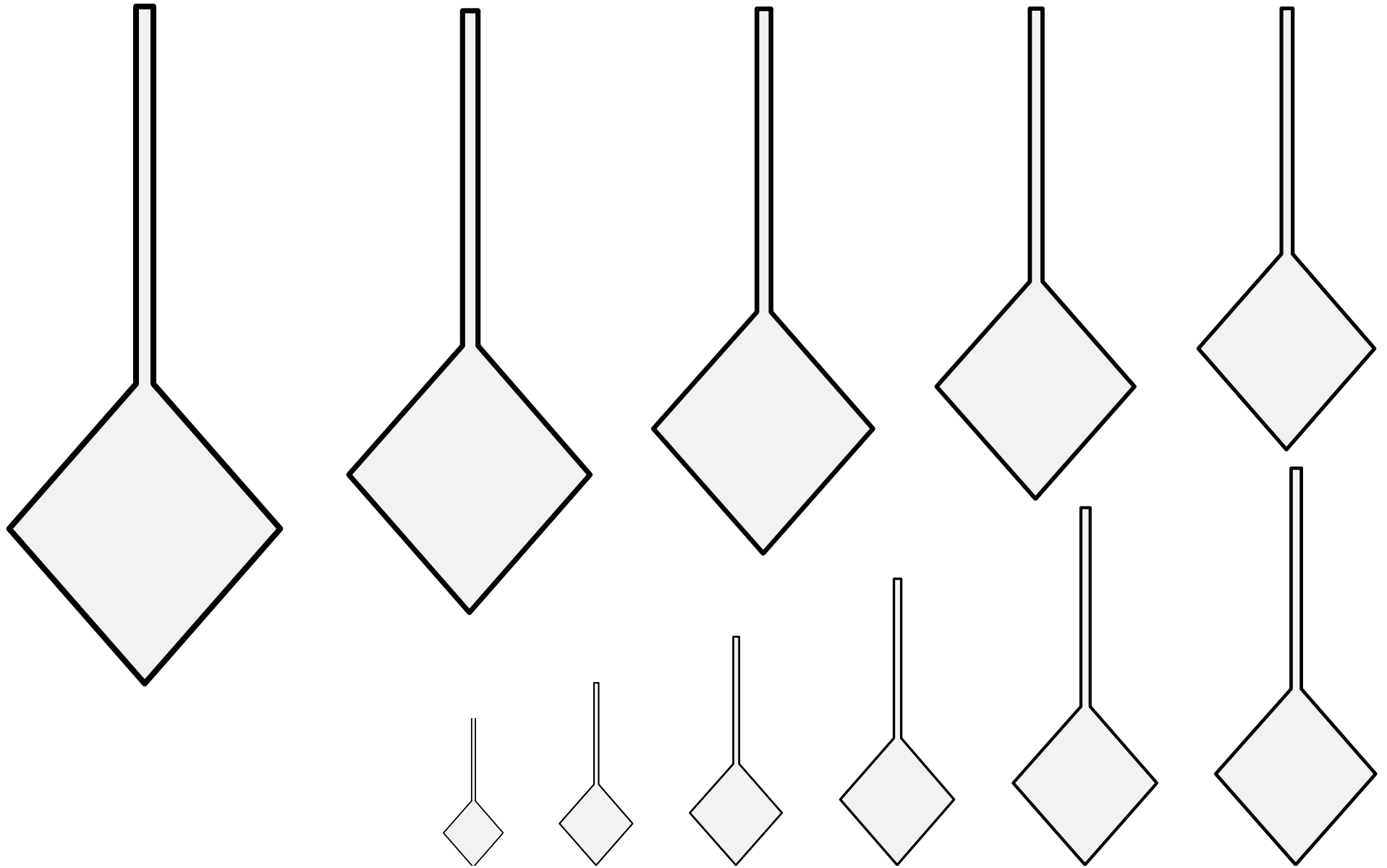

A symbol used to mark the the pitch and timing of a musical note.

Default alignment: upright. No proper coloration.

Source: Pennsic Traceable Art. Artist: Unknown.

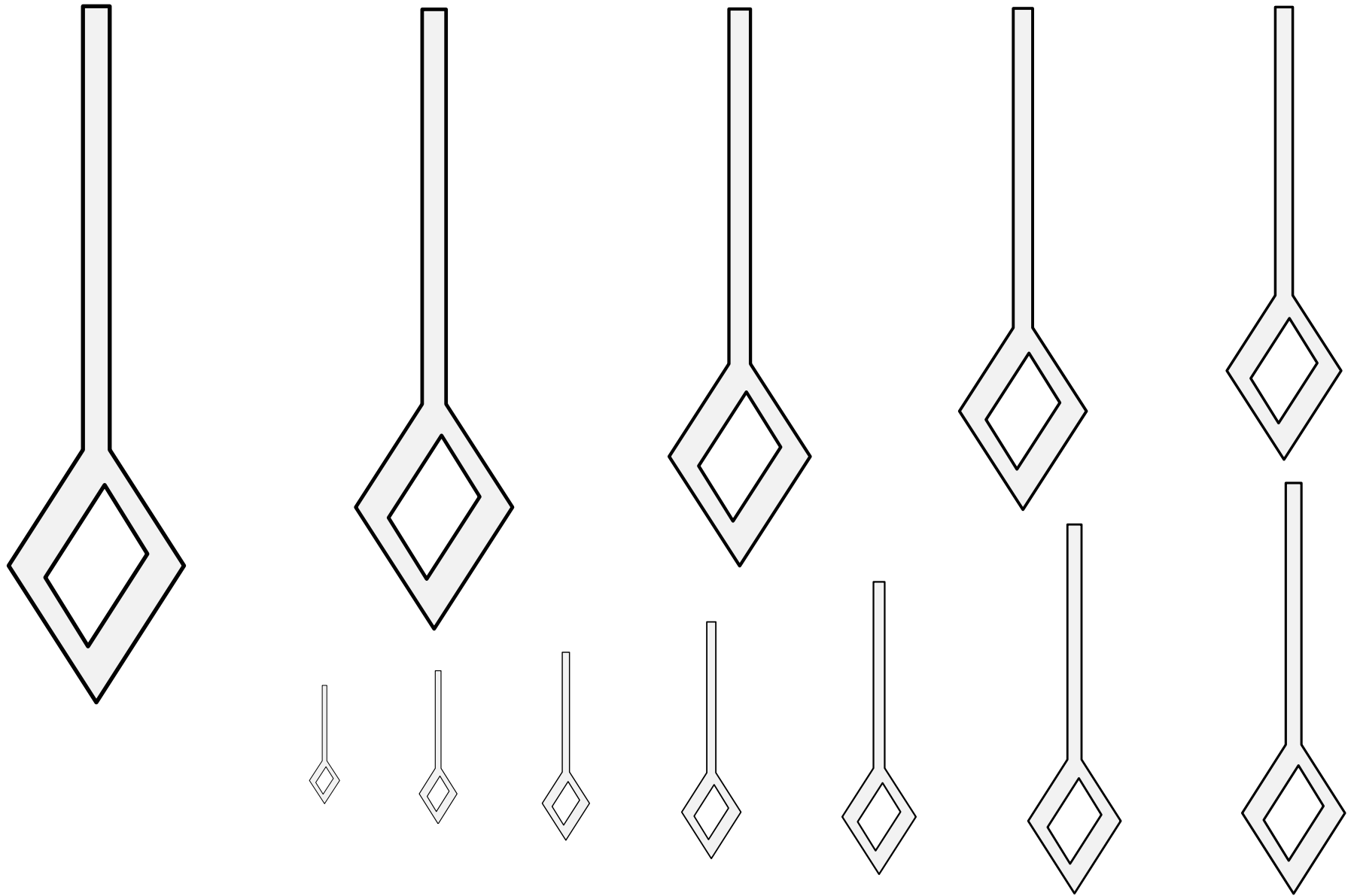

A symbol used to mark the the pitch and timing of a musical note.

Default alignment: upright. No proper coloration.

This form was used to represent a half note in the 15th century.

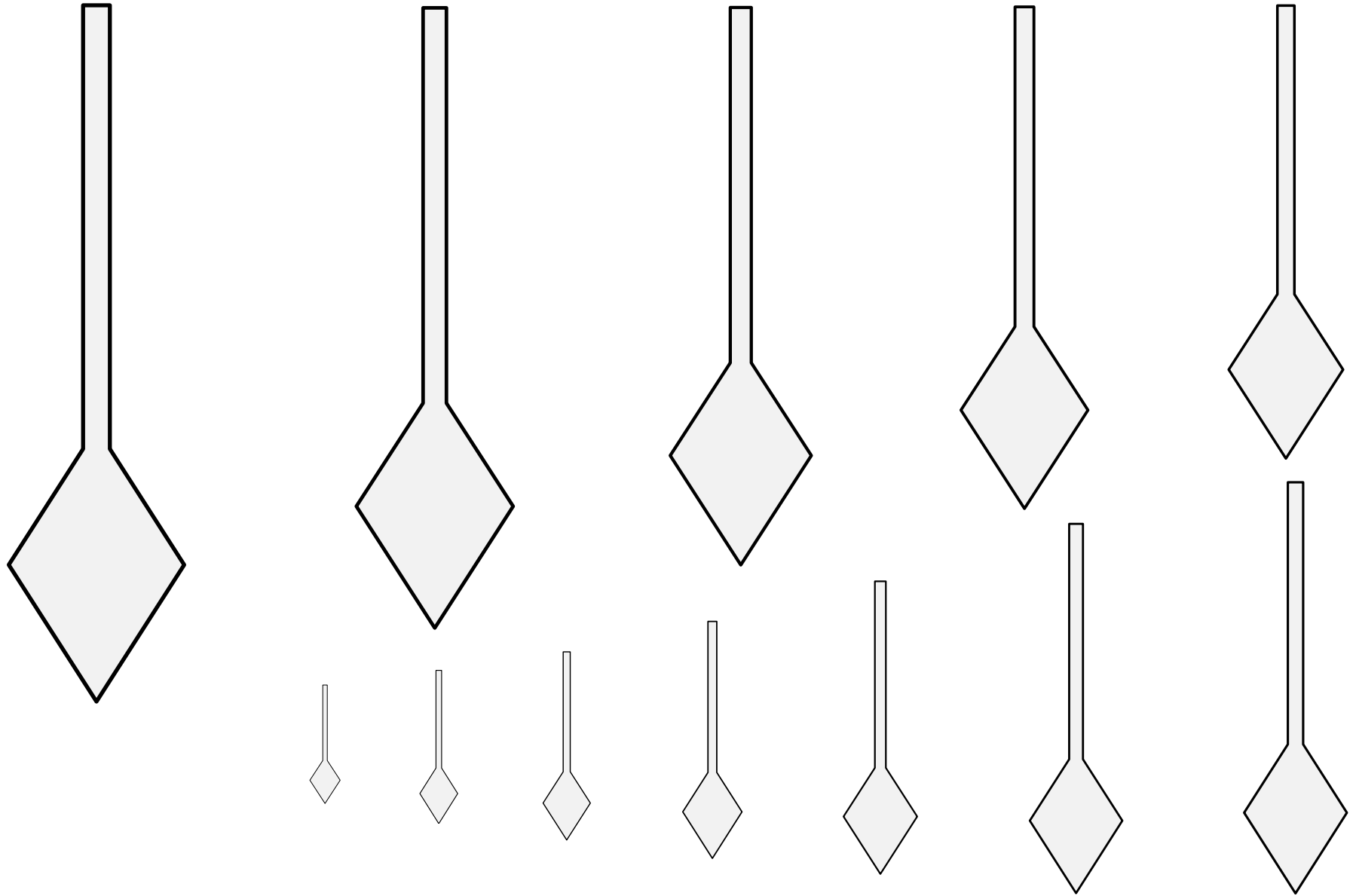

A symbol used to mark the the pitch and timing of a musical note.

Default alignment: upright. No proper coloration.

This form was used to represent a half note in the 14th century and a quarter note in the 15th century.

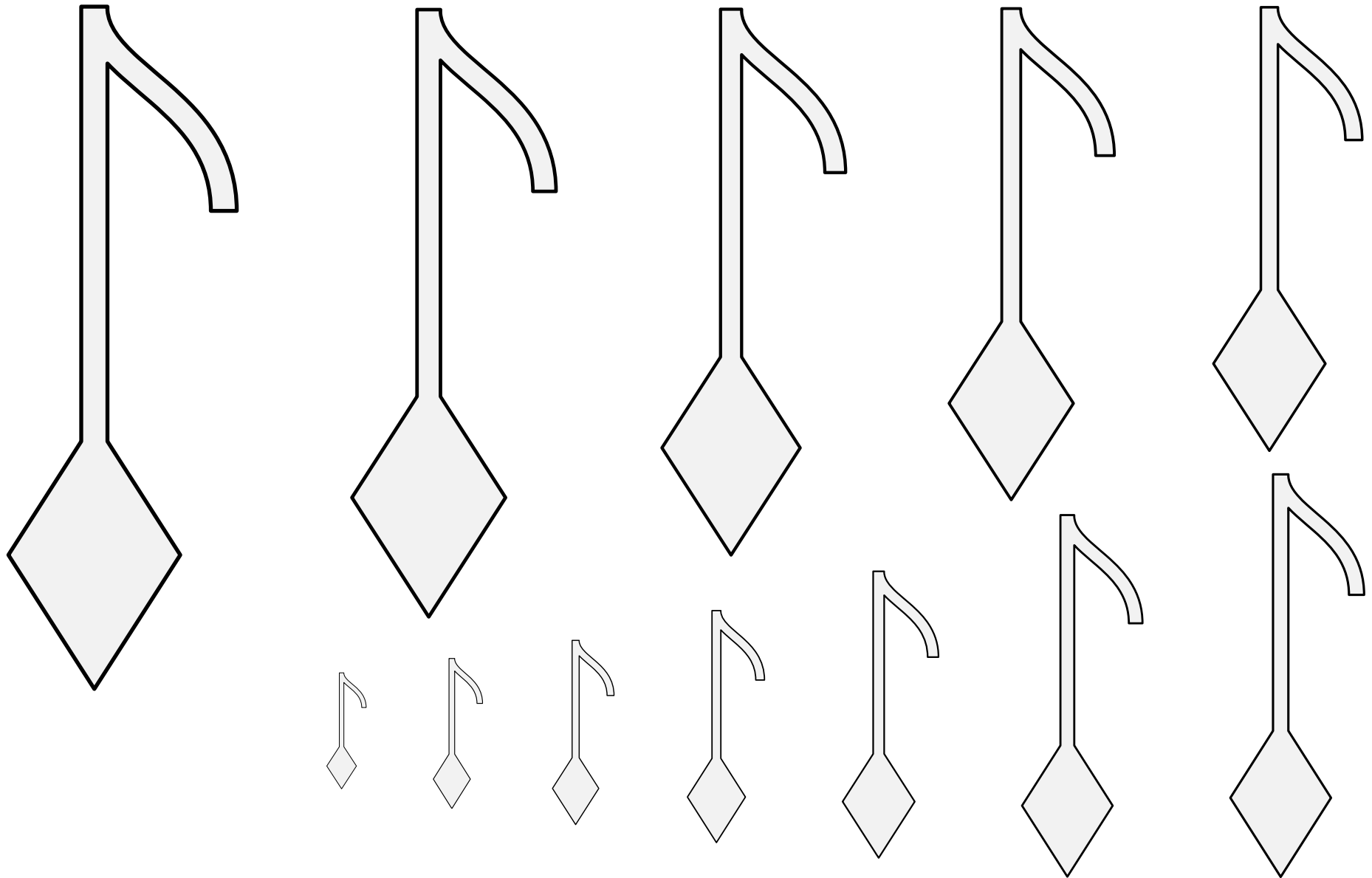

A symbol used to mark the the pitch and timing of a musical note.

Default alignment: upright. No proper coloration.

This form was used to represent a quarter note in the 14th century and an eighth note in the 15th century.

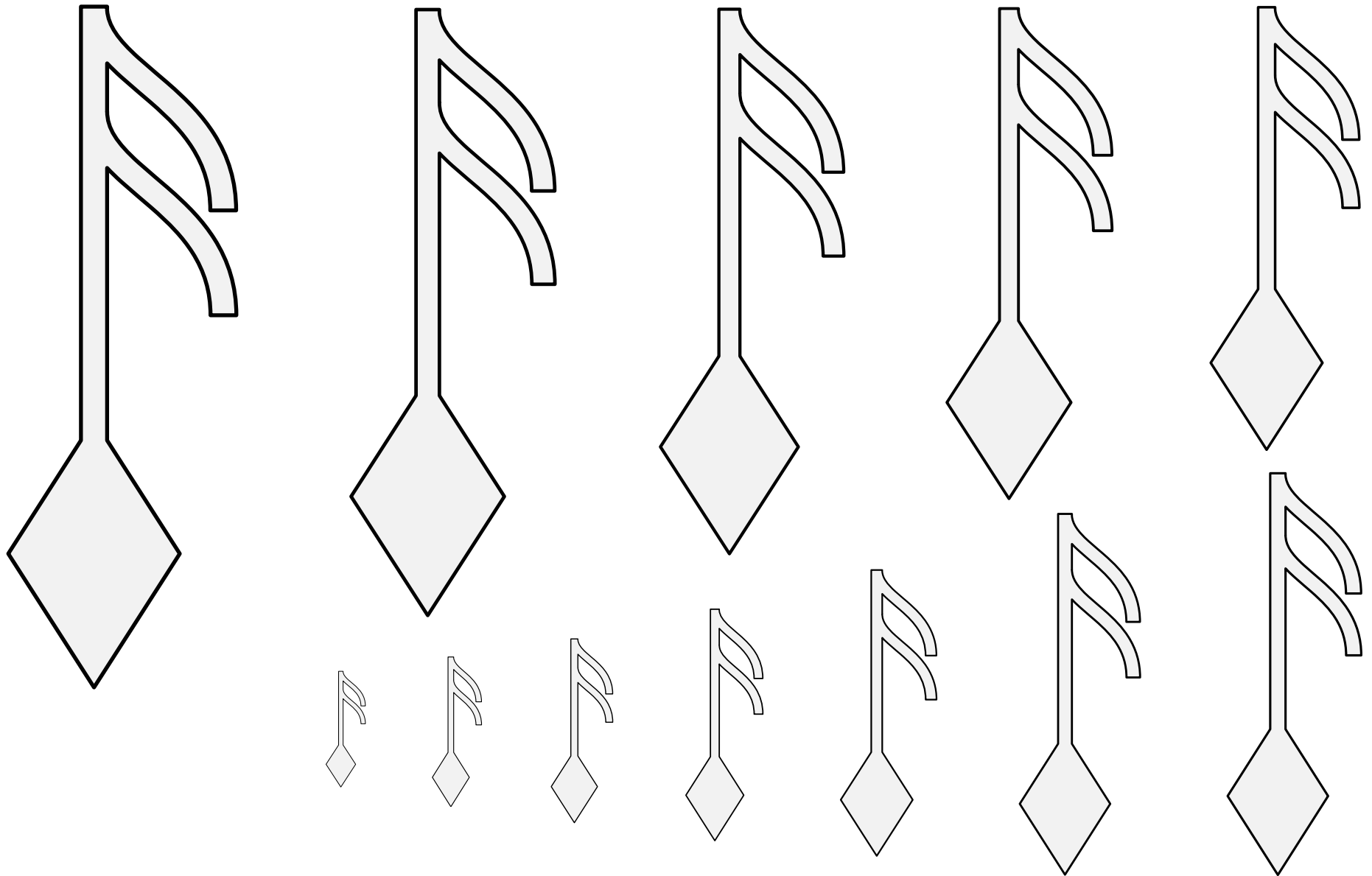

A symbol used to mark the the pitch and timing of a musical note.

Default alignment: upright. No proper coloration.

This form was used to represent an eighth note in the 14th century and a sixteenth note in the 15th century.

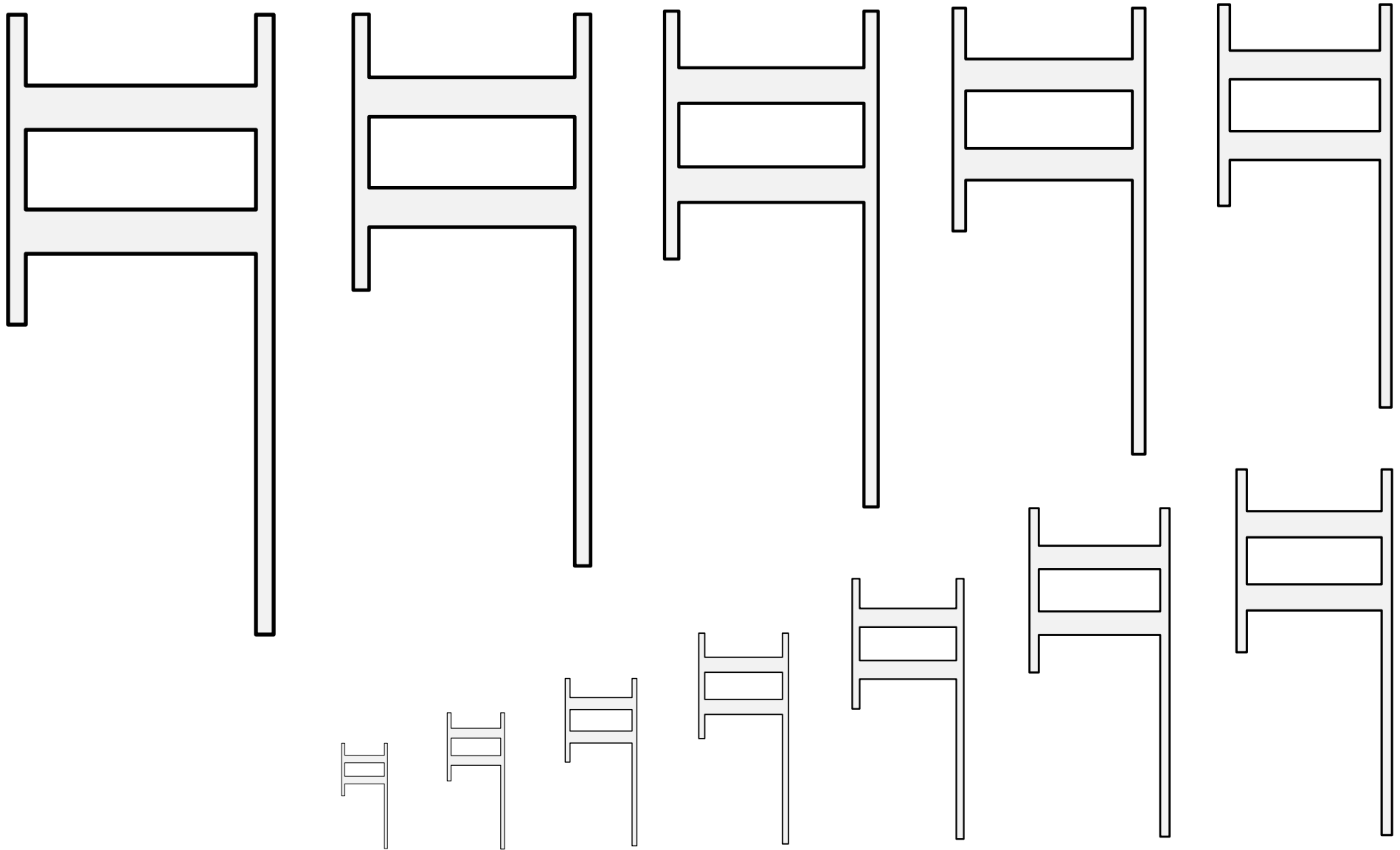

A symbol used to mark the the pitch and timing of a musical note.

Default alignment: upright. No proper coloration.

This form was used to represent a *longa*, or quadruple whole note, in the 15th century.

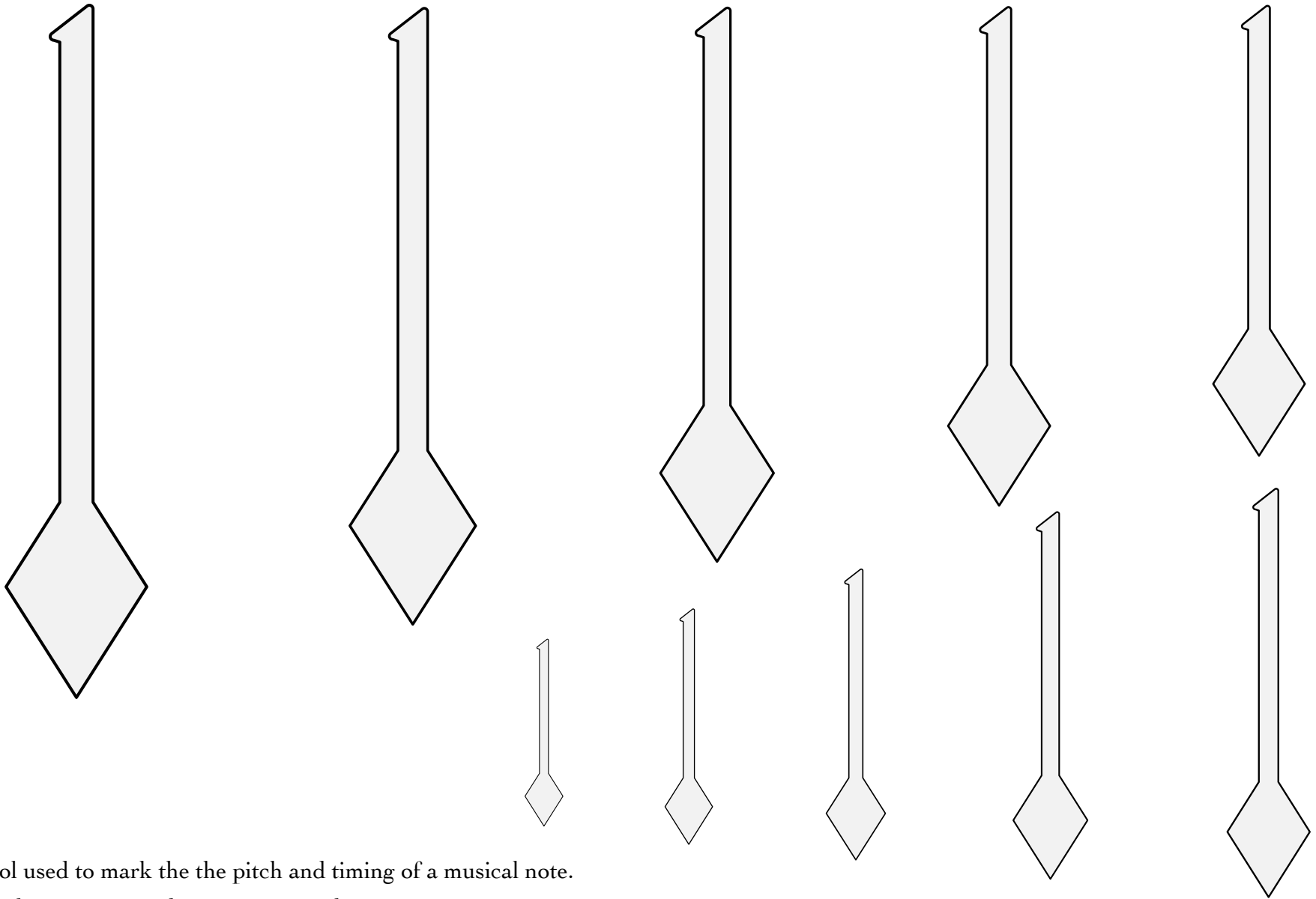

A symbol used to mark the the pitch and timing of a musical note.

Default alignment: upright. No proper coloration.

This form was used to represent a half note in the 14th century and a quarter note in the 15th century.

Source: Frottole Libro Secondo. (1504) Artist unknown.

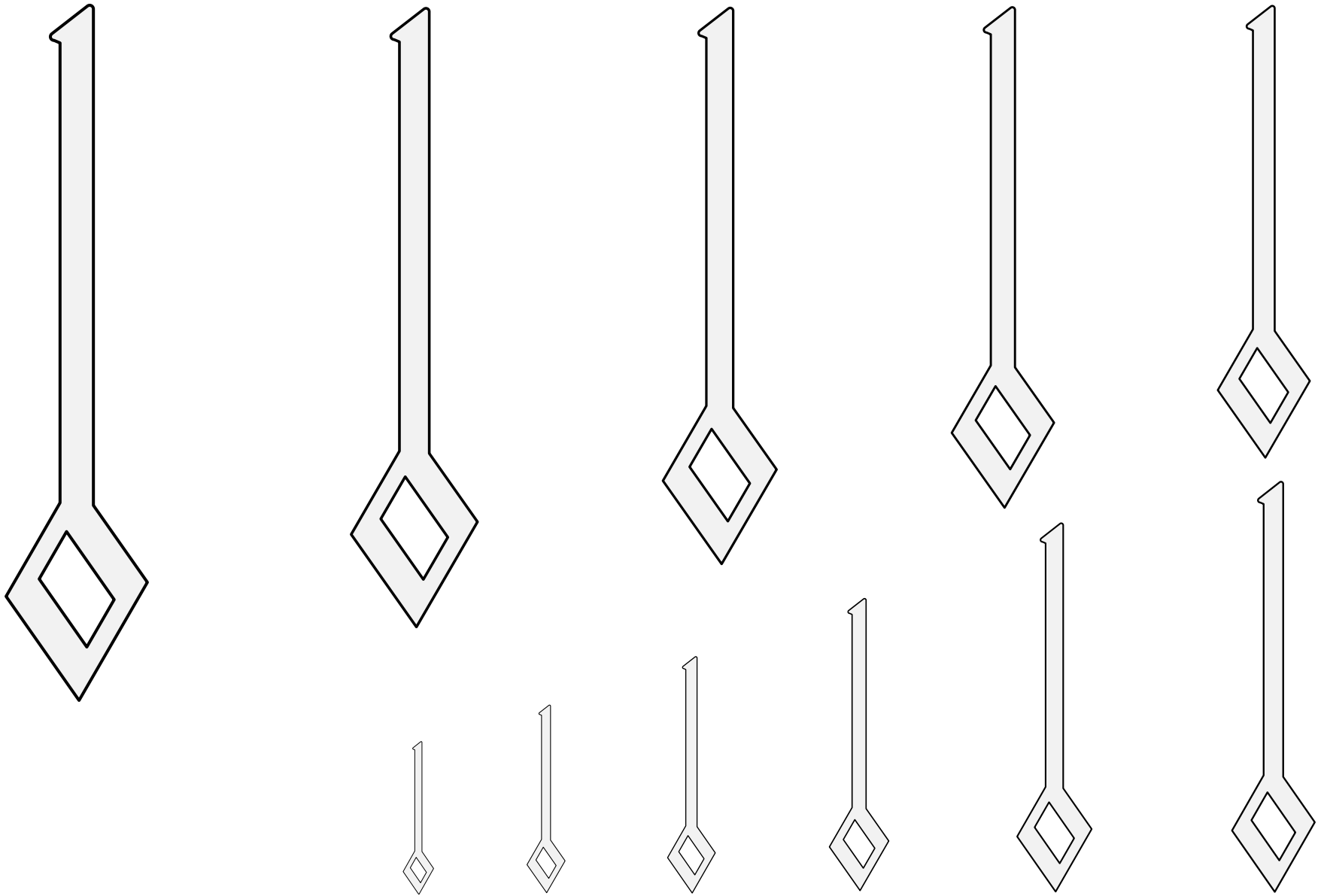

A symbol used to mark the the pitch and timing of a musical note.

Default alignment: upright. No proper coloration.

Source: Frottole Libro Secondo. (1504) Artist unknown.

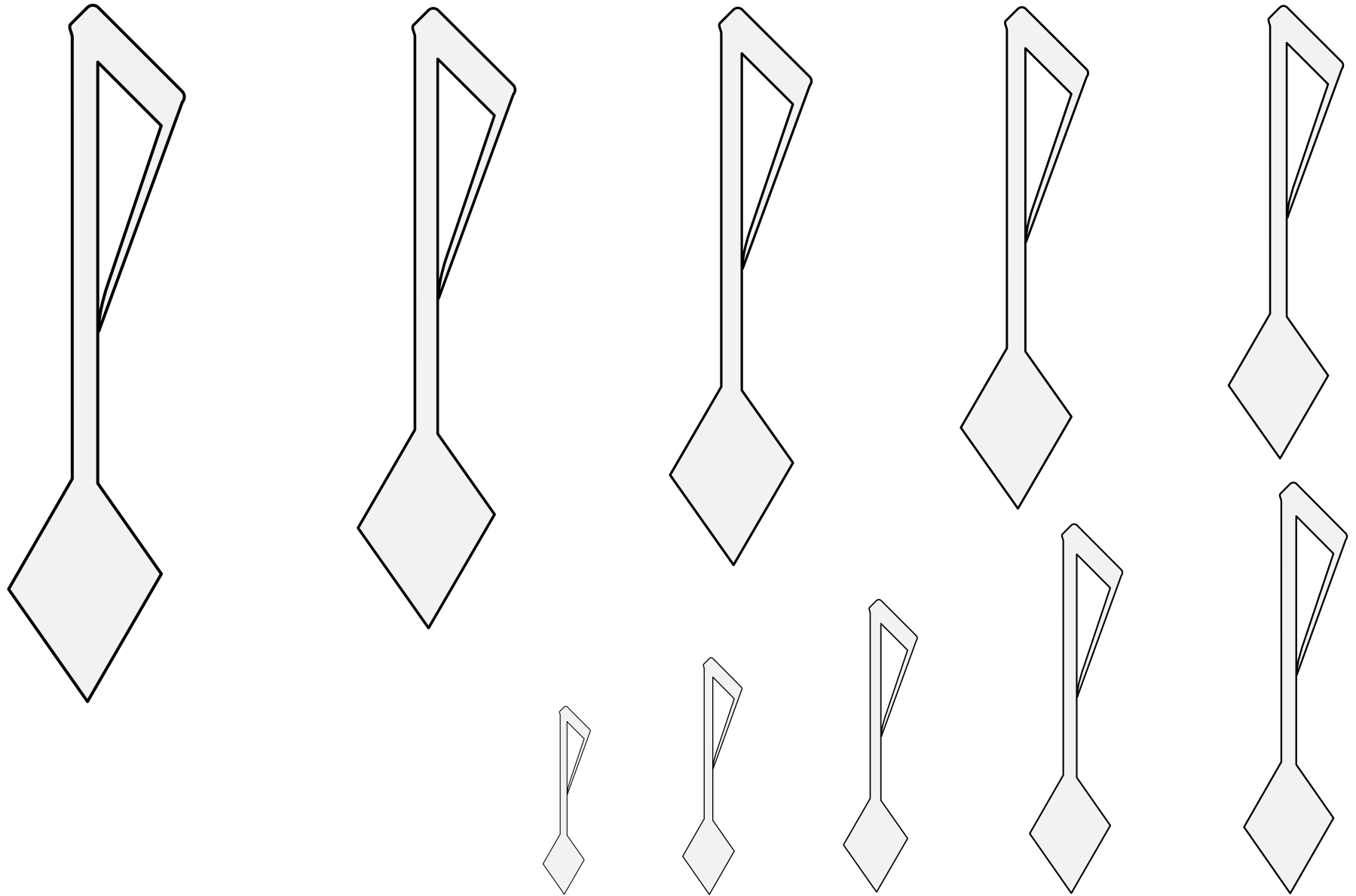

A symbol used to mark the the pitch and timing of a musical note.

Default alignment: upright. No proper coloration.

Source: Frottole Libro Secondo. (1504) Artist unknown.

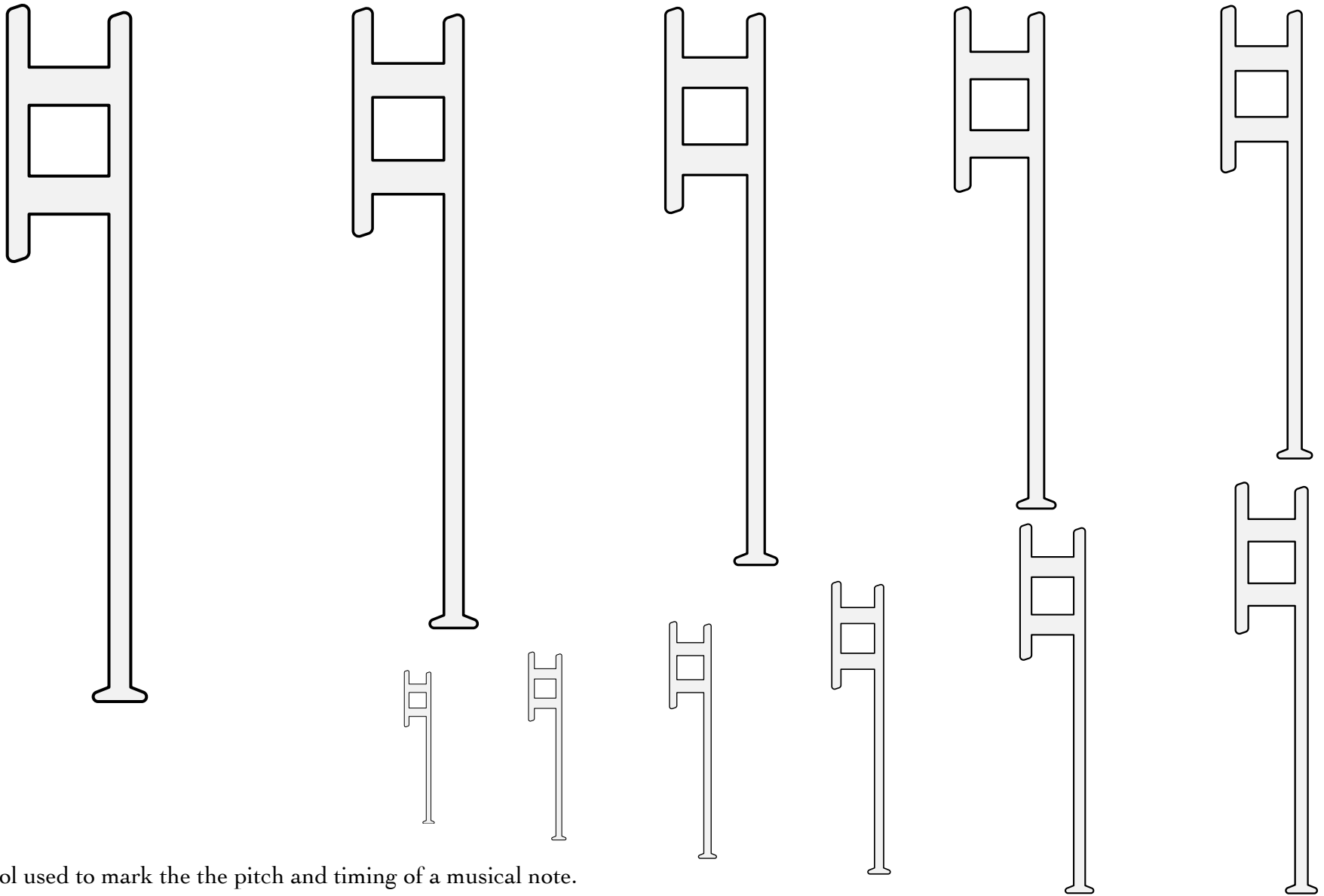

A symbol used to mark the the pitch and timing of a musical note.

Default alignment: upright. No proper coloration.

This form was used to represent a *longa*, or quadruple whole note, in the 15th century.

Source: Frottole Libro Secondo. (1504) Artist unknown.

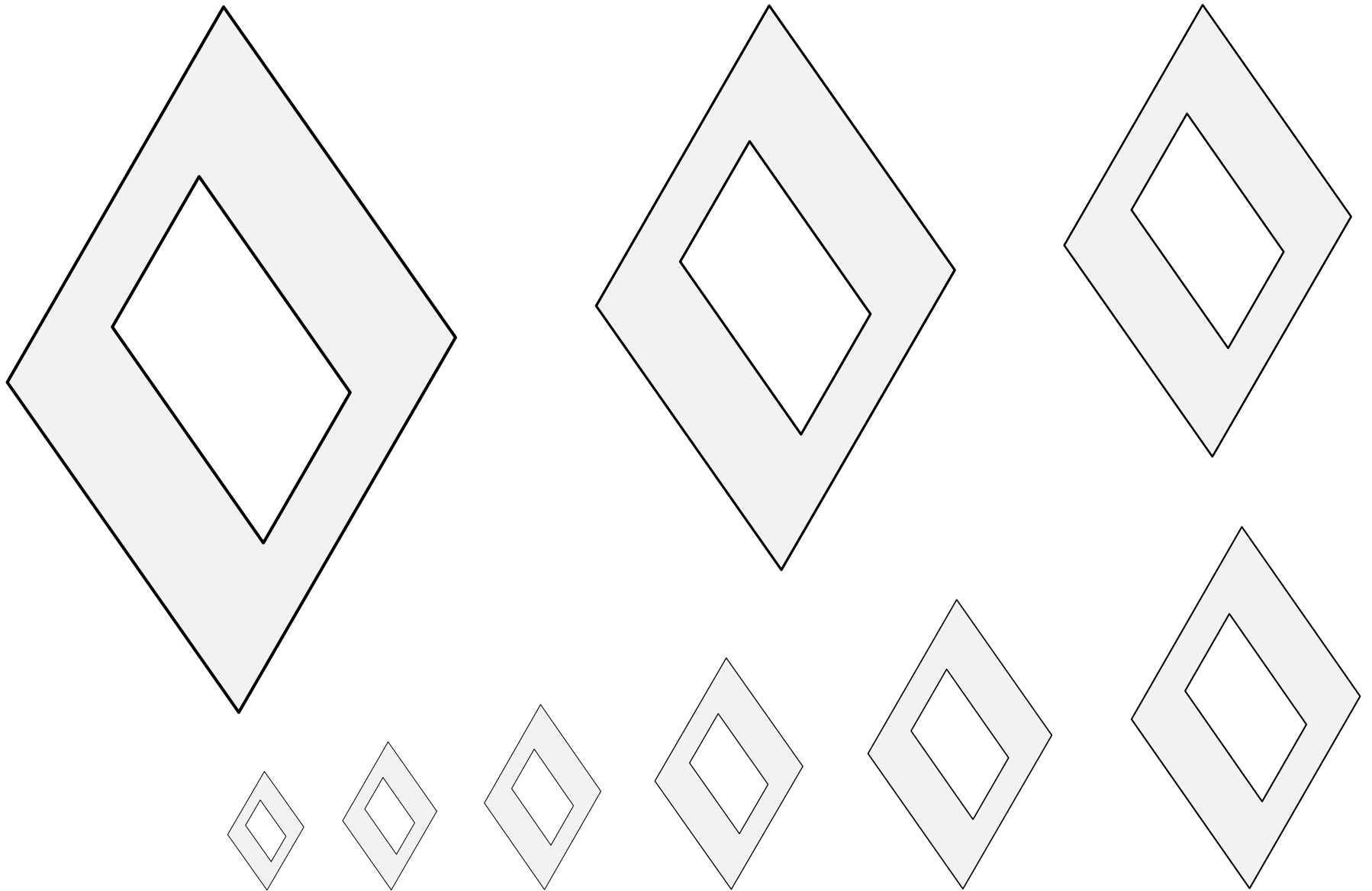

A symbol used to mark the the pitch and timing of a musical note.

Default alignment: upright. No proper coloration.

Source: Frottole Libro Secondo. (1504) Artist unknown.

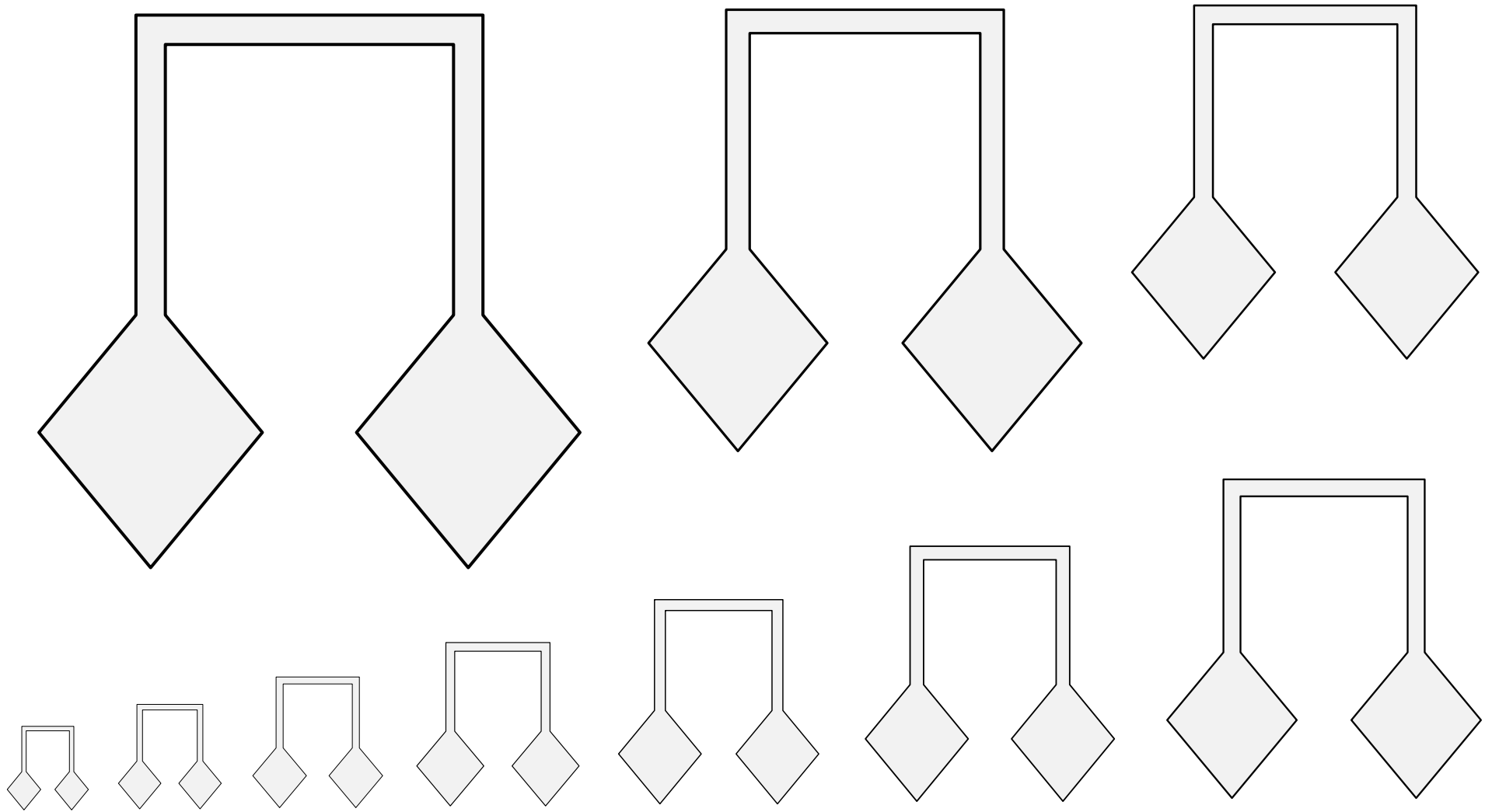

A symbol used to mark the the pitch and timing of a musical note.

Default alignment: upright.
No proper coloration.

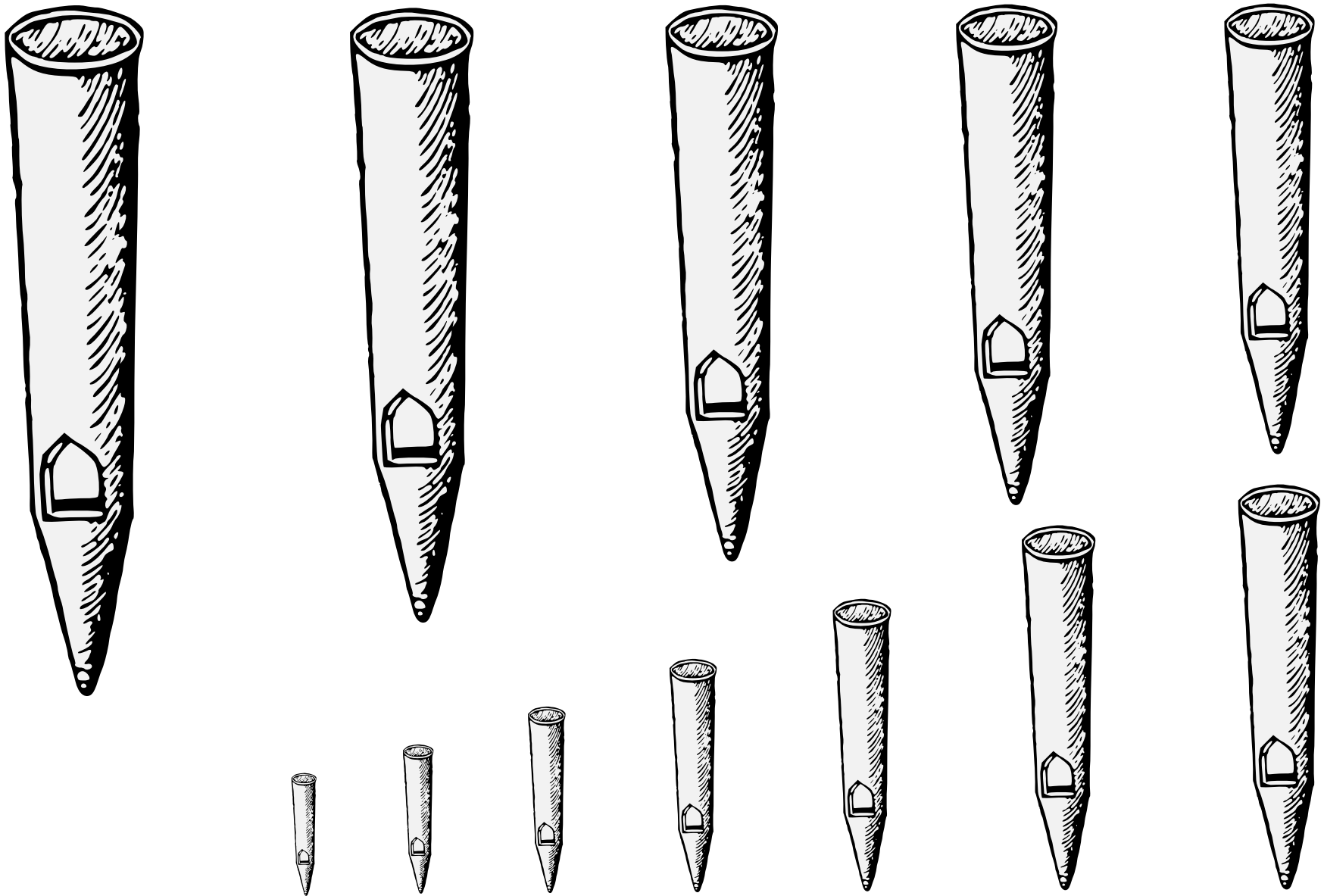

A sounding tube from a keyboard-driven wind instrument.

Default orientation: palewise, open end to chief. No proper coloration.

Source: Guillim's Display of Heraldry. Artist unknown.

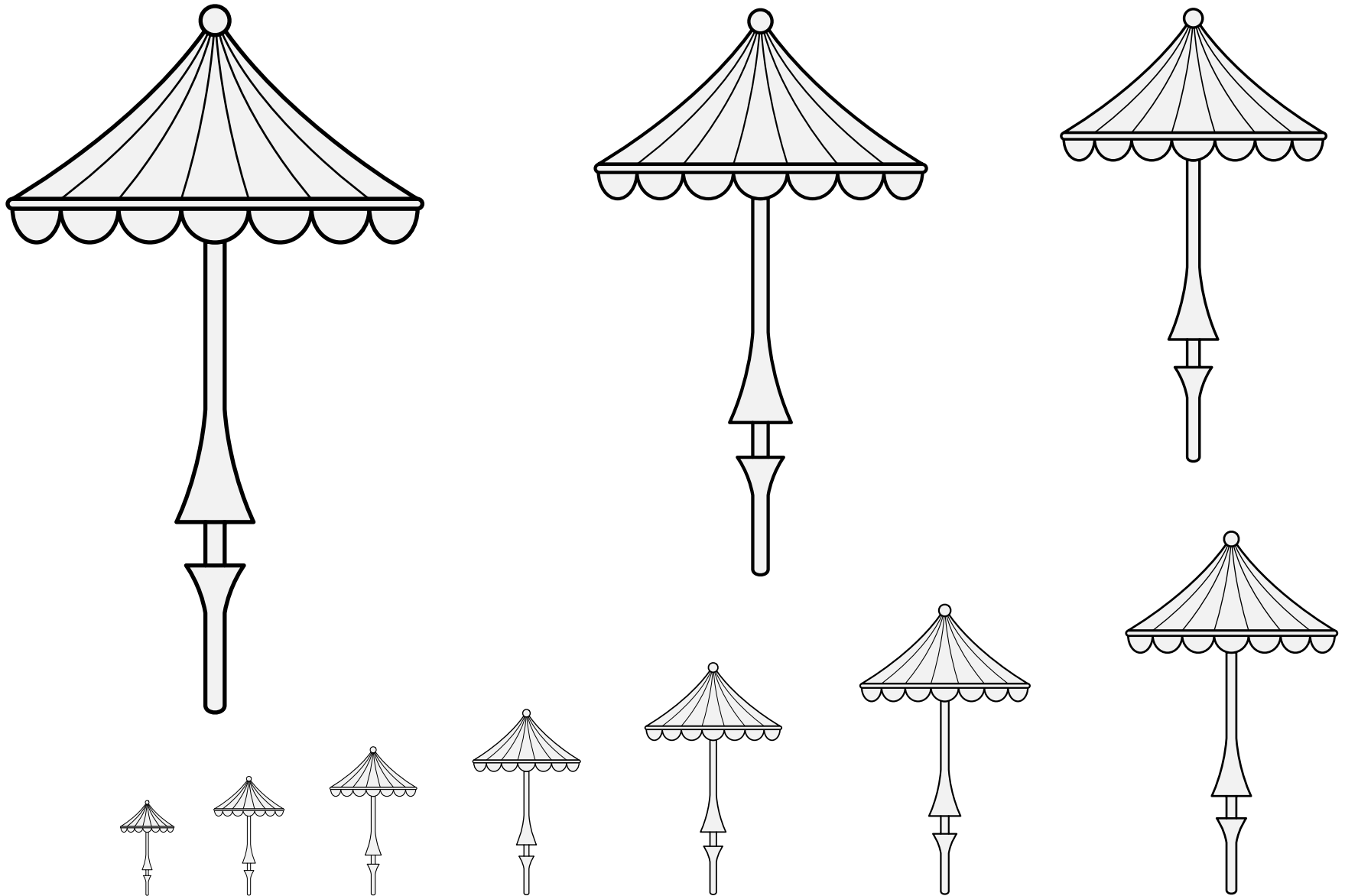

A ceremonial umbrella or parasol. Appears in the arms of the pope.
Default orientation: handle to base. No proper coloration.

Ombrellino (1) 18.146

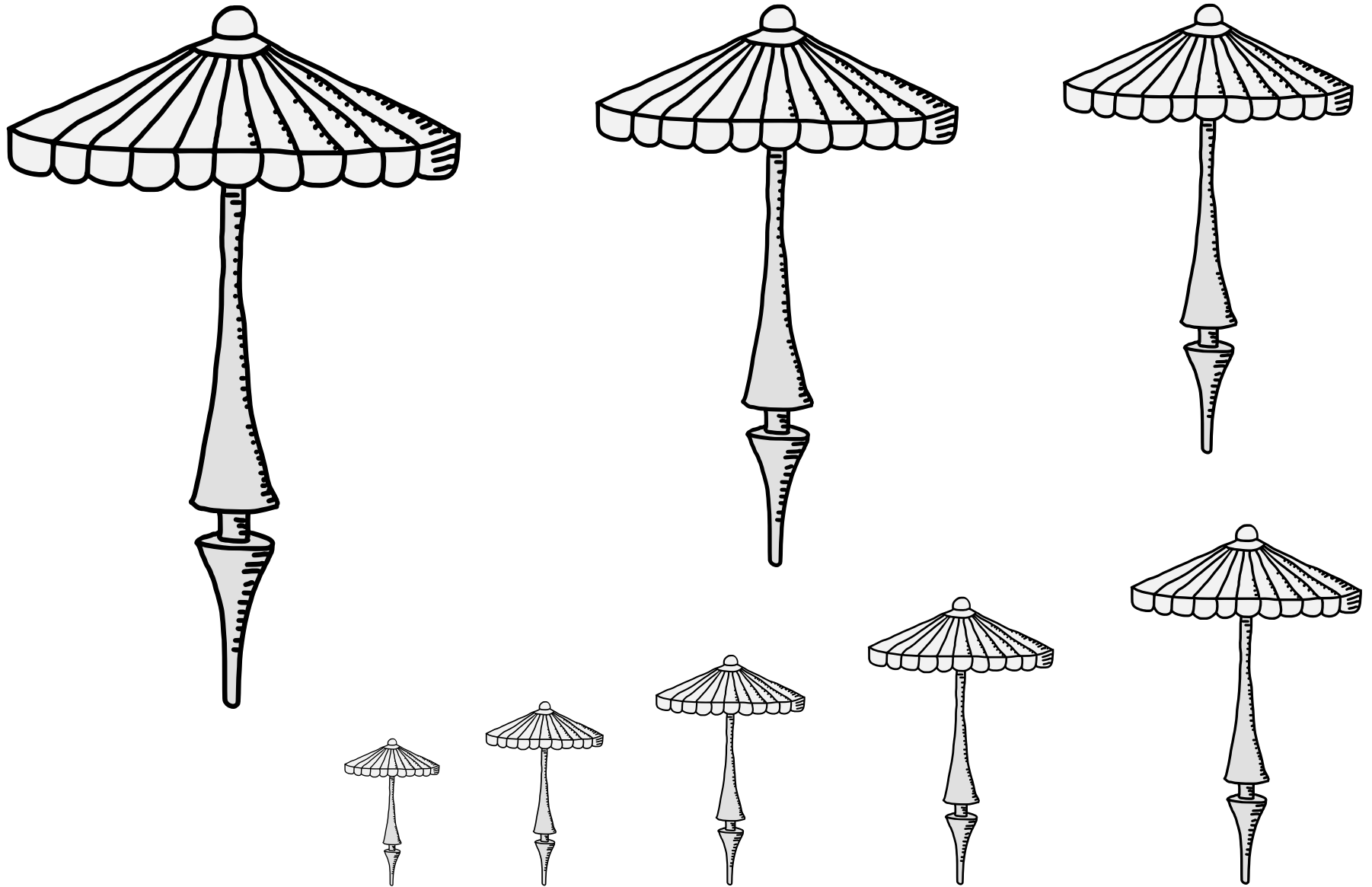

A ceremonial umbrella or parasol. Appears in the arms of the pope.
Default orientation: handle to base. No proper coloration.
Artist: Sadhbh Bheag.

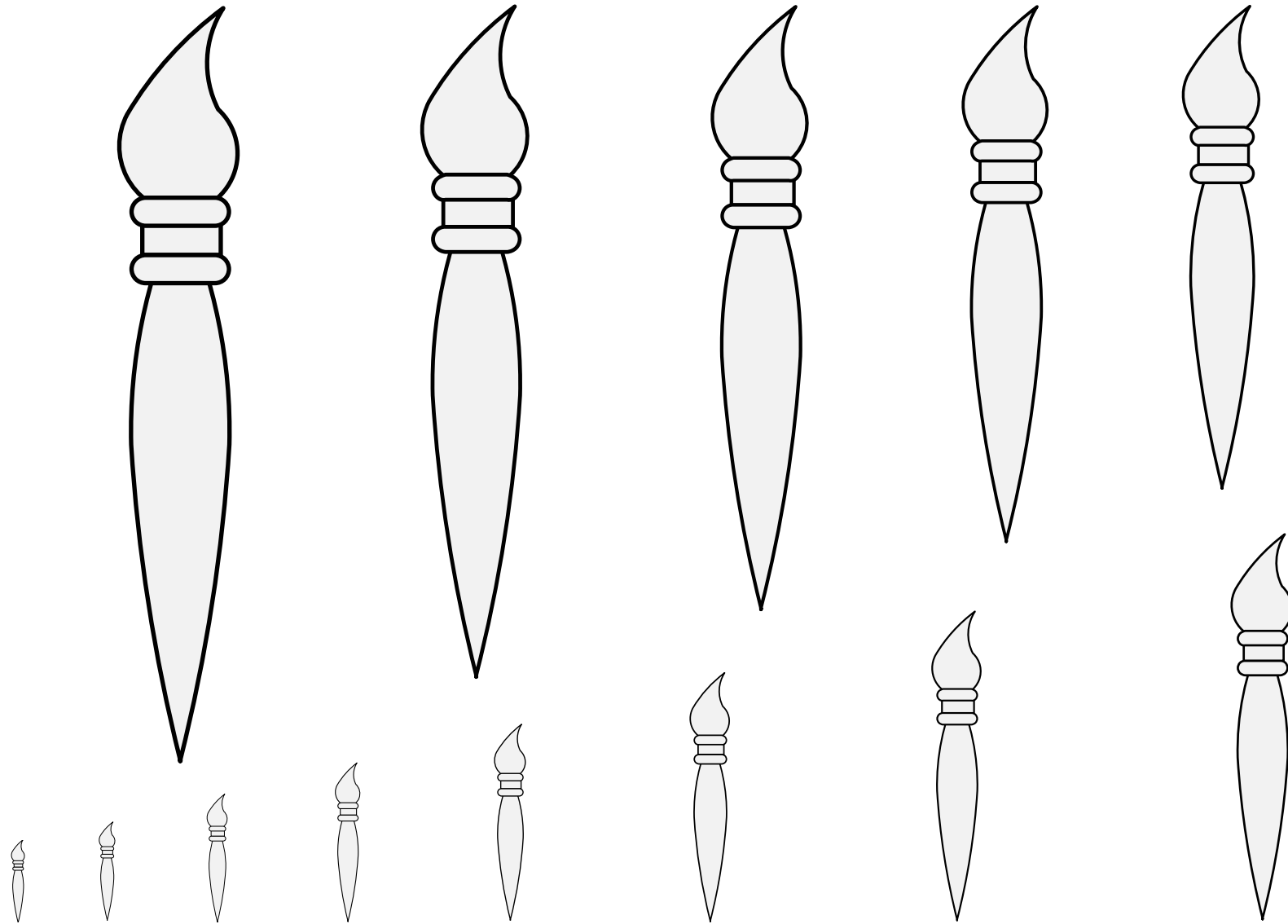

A tool for applying paint.

Default orientation: palewise, brush to chief. Proper coloration: brown wood handle, sable bristles.

Source: Viking Answer Lady SVG Images For Heralds.

Artist: Gunnvôr silfrahárr.

Paintbrush, Artist's (1) 18.148

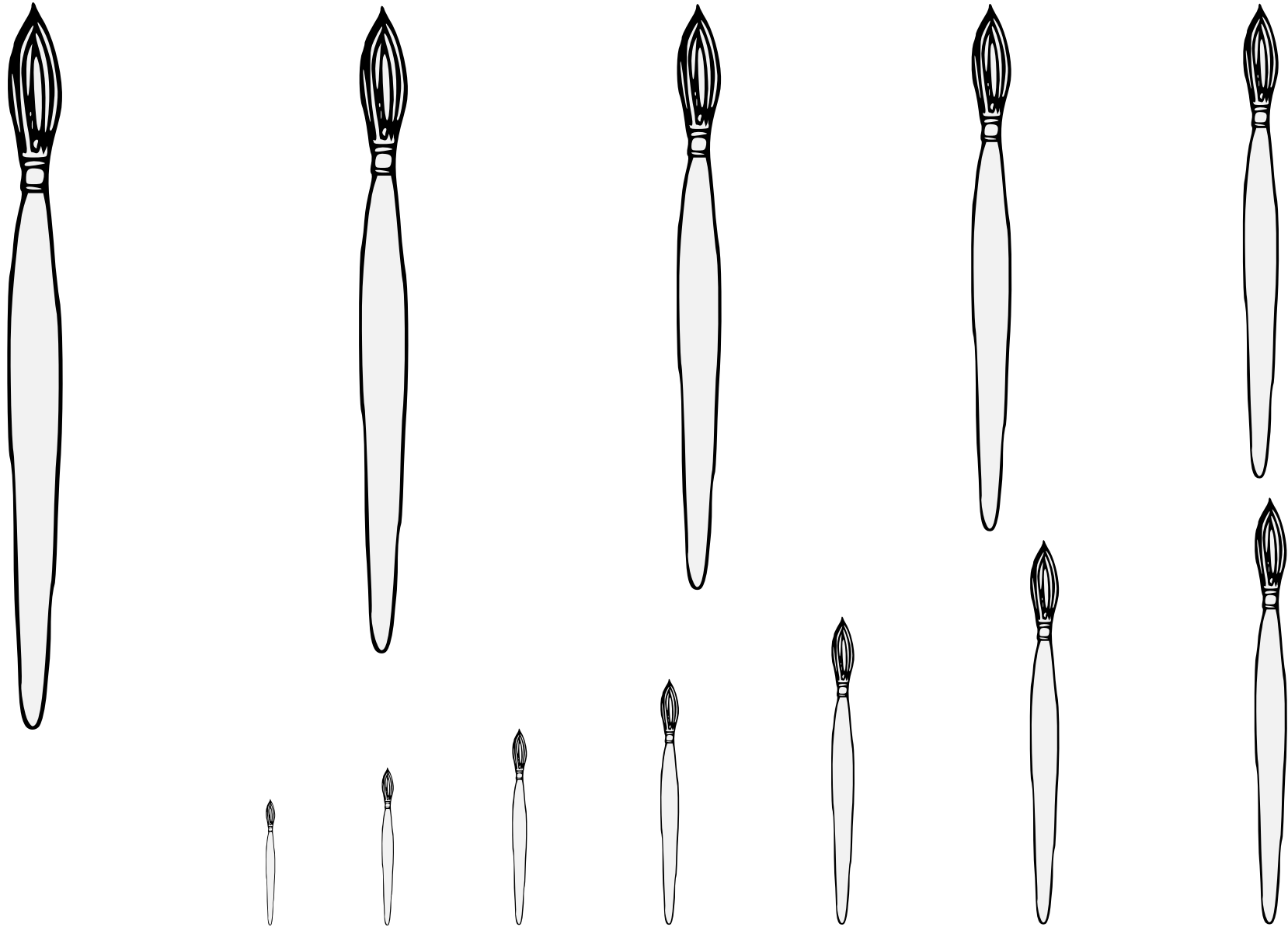

A tool for applying paint.

Default orientation: palewise, brush to chief. Proper coloration: brown wood handle, sable bristles.

Source: Pennsic Traceable Art. Artist unknown.

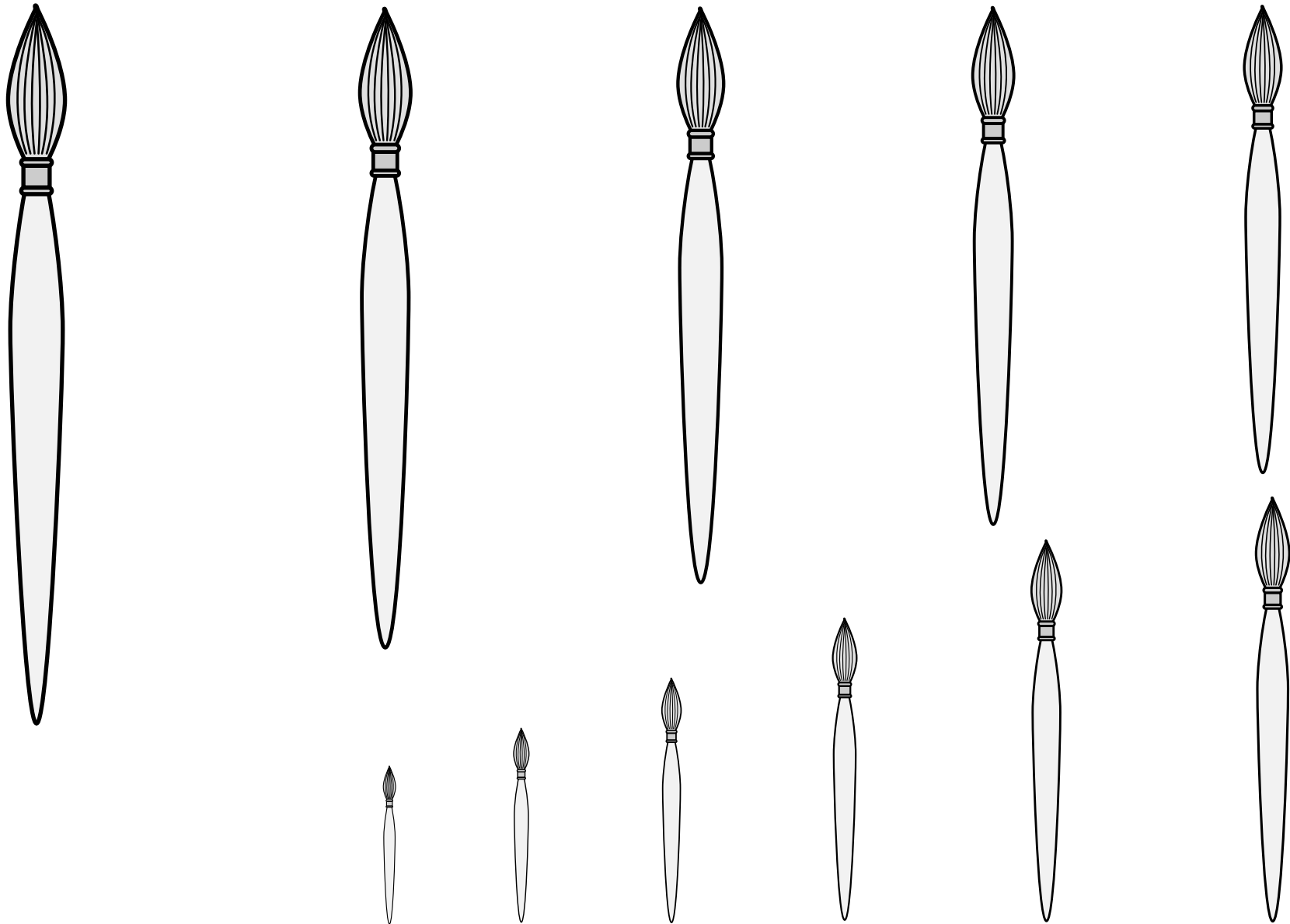

A tool for applying paint.

Default orientation: palewise, brush to chief. Proper coloration: brown wood handle, sable bristles.

Source: Pennsic Traceable Art. Artist unknown.
Adapted by Mathghamhain Ua Ruadháin.

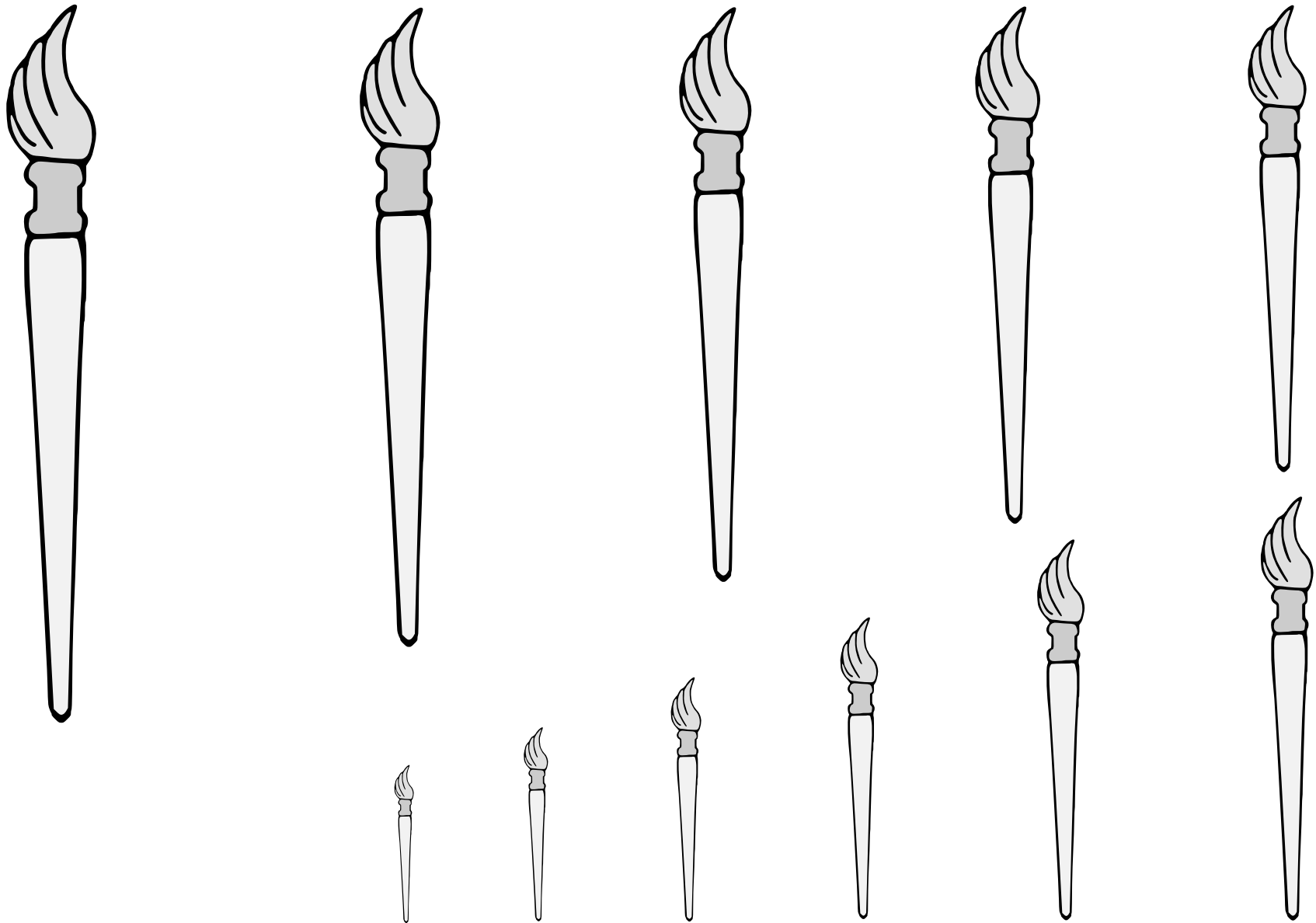

A tool for applying paint.

Default orientation: palewise, brush to chief.

Proper coloration: brown wood handle, sable bristles.

Artist: Jessimond of Emerickeskepe.

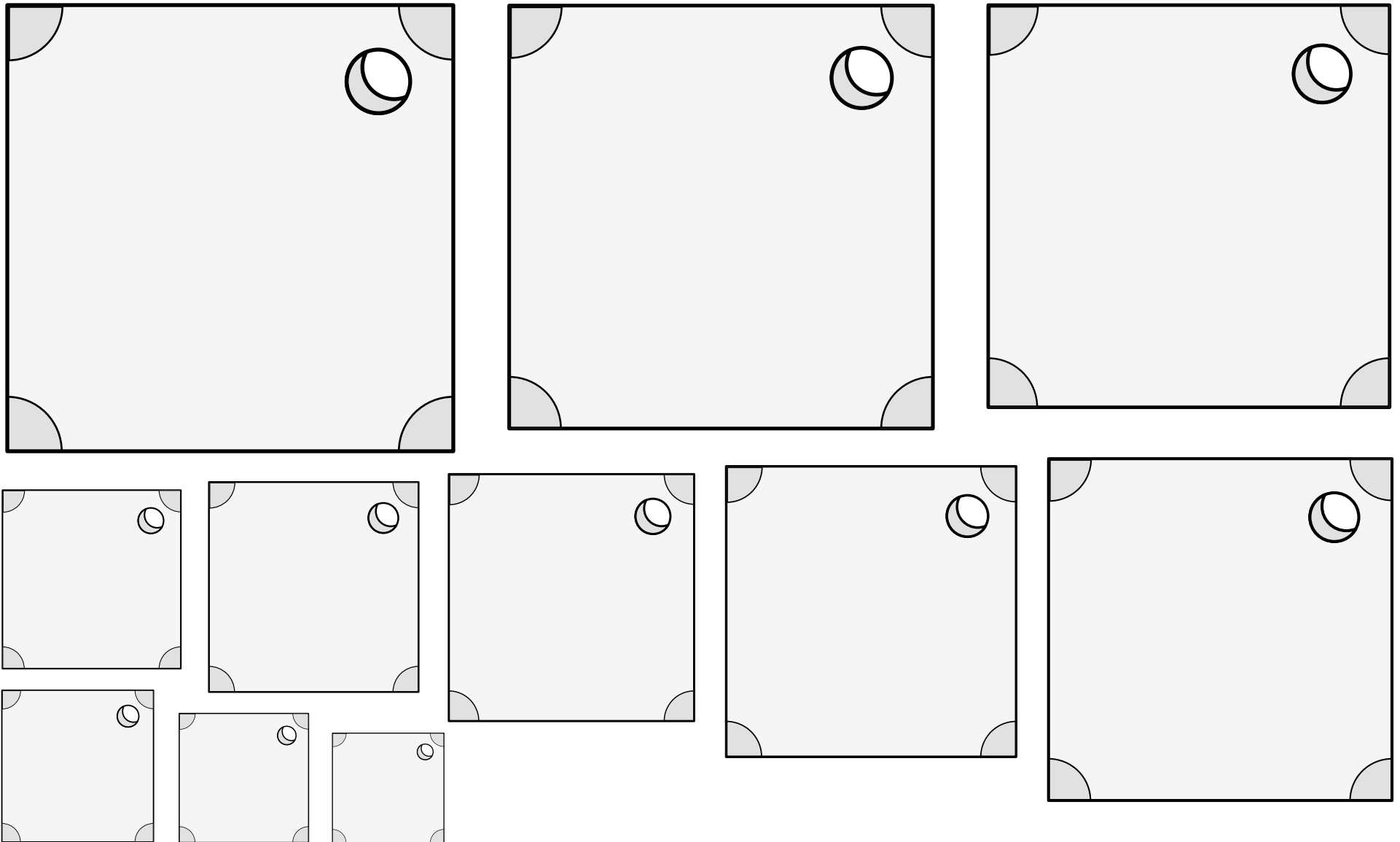

A wooden surface used for mixing paint.

No default orientation. No proper coloration.

Source: A Display of Heraldry. Artist: John Guillim.
(Manuscript folio 106r.) Adapted by Iago ab Adam.

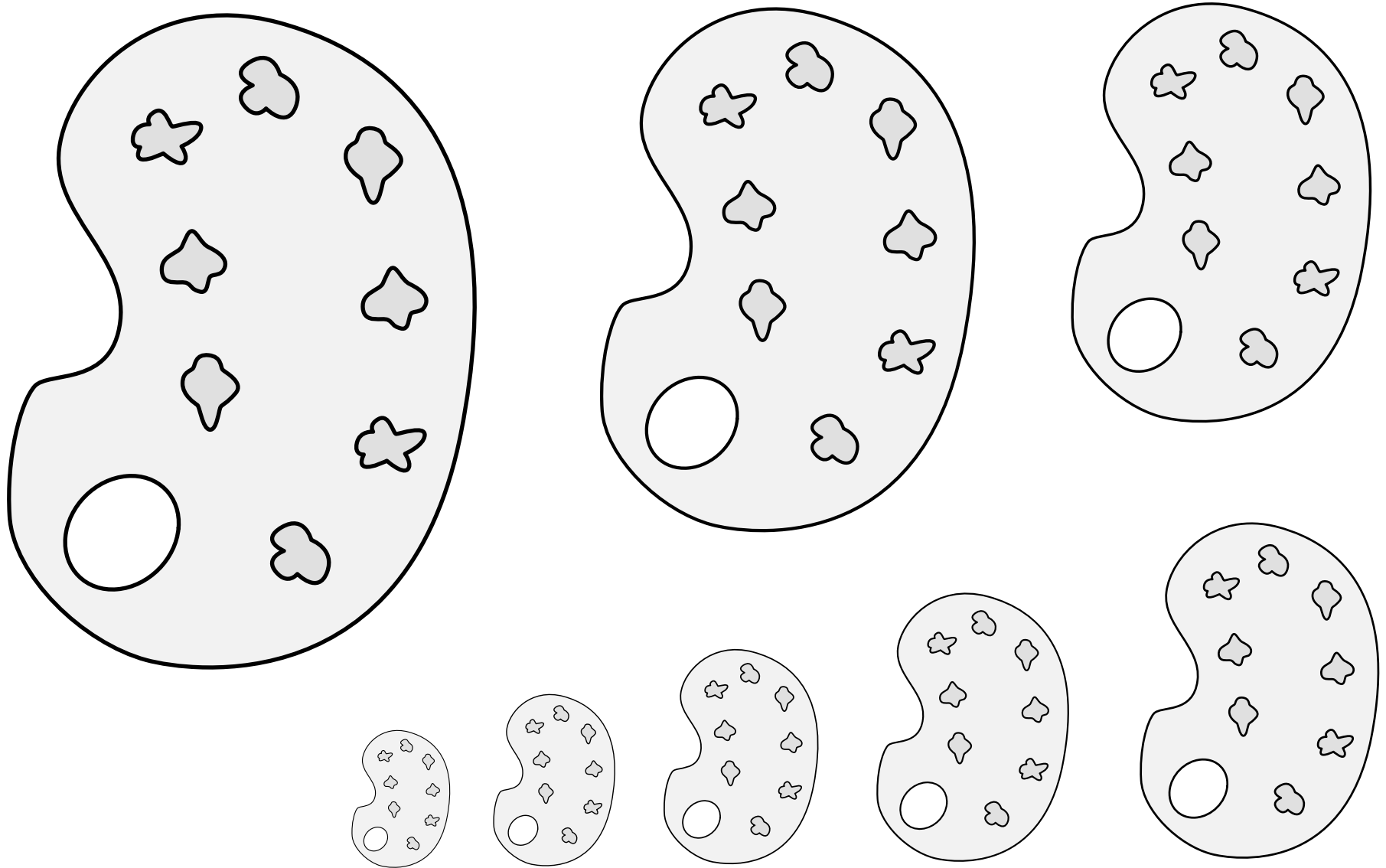

A wooden surface used for mixing paint.

No default orientation. No proper coloration.

Adapted from an engraved portrait
circa 1600 of painter Hans Bol
by Hendrik Hondius the Elder.

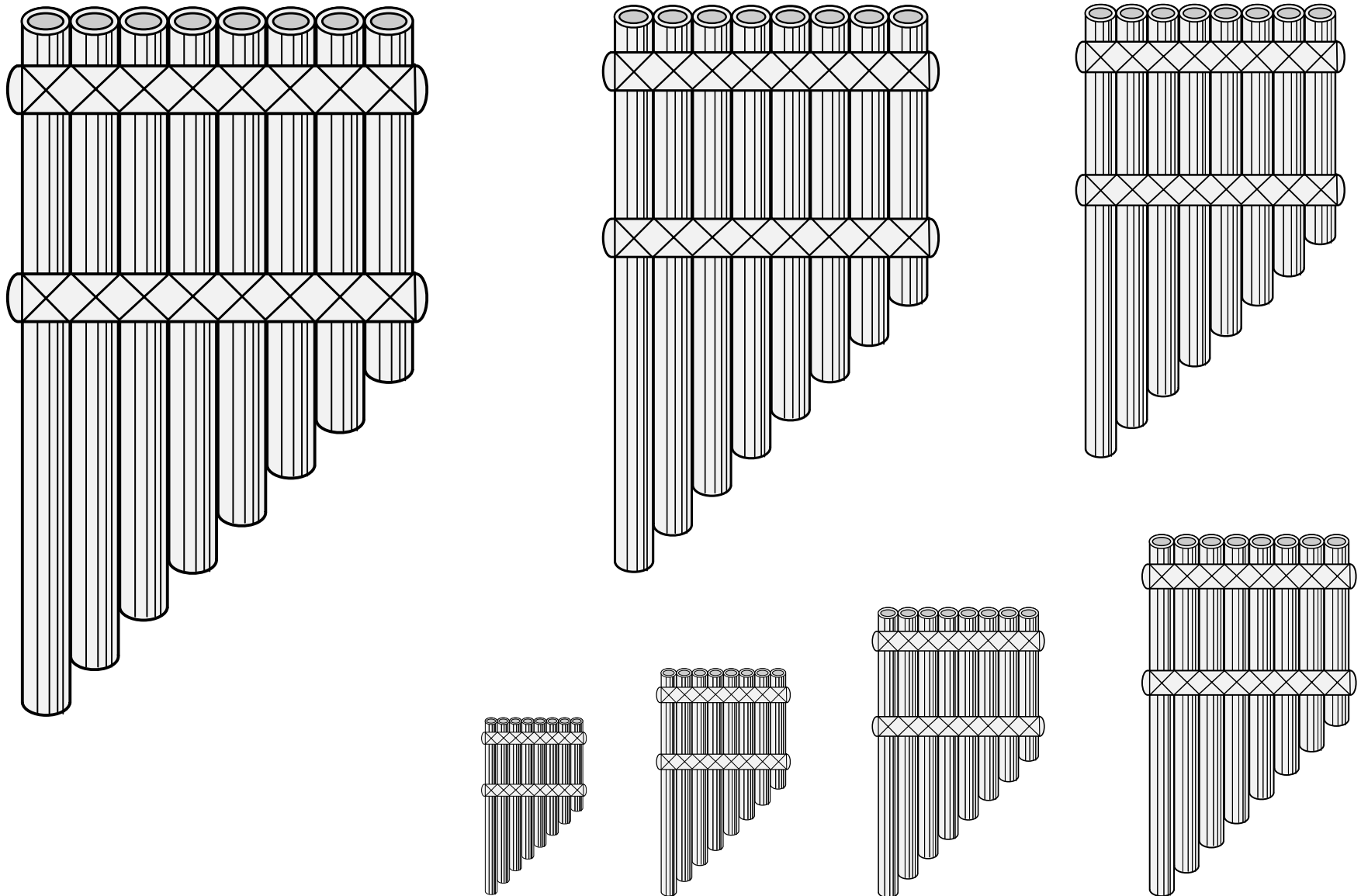

A simple wind instrument.

Default orientation: palewise. No proper coloration.

Source: Viking Answer Lady SVG Images For Heraldists. Artist: Gunnvôr silfrahárr.

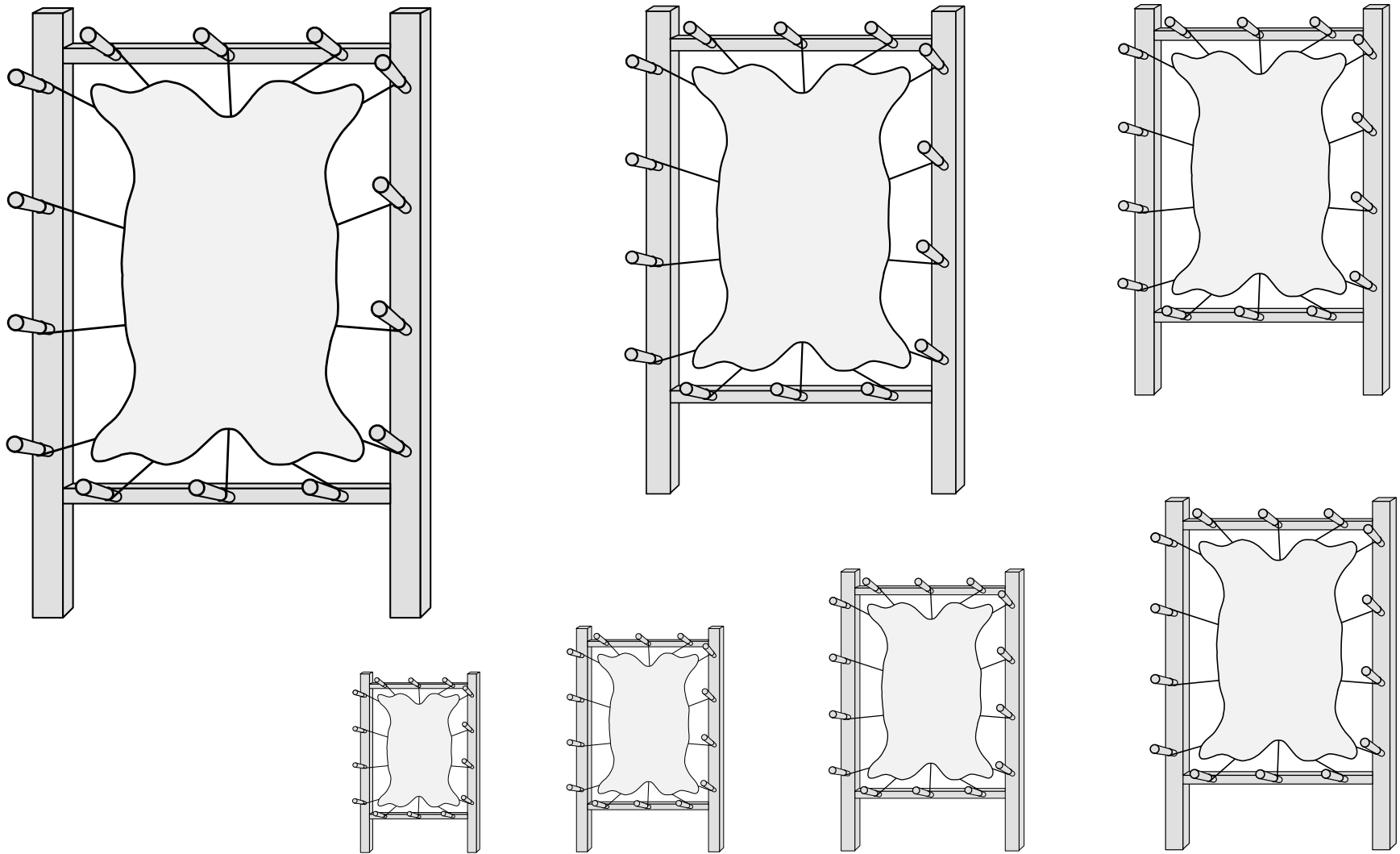

A wooden frame used to stretch hides when preparing parchment, also called a "parchmenter's herse."

Default orientation: legs to base. Proper coloration: brown wood.

Adapted from Hausbuch der Mendelschen Zwölfbrüderstiftung.
(Circa 1425.)

Parchmenter's Frame 18.155

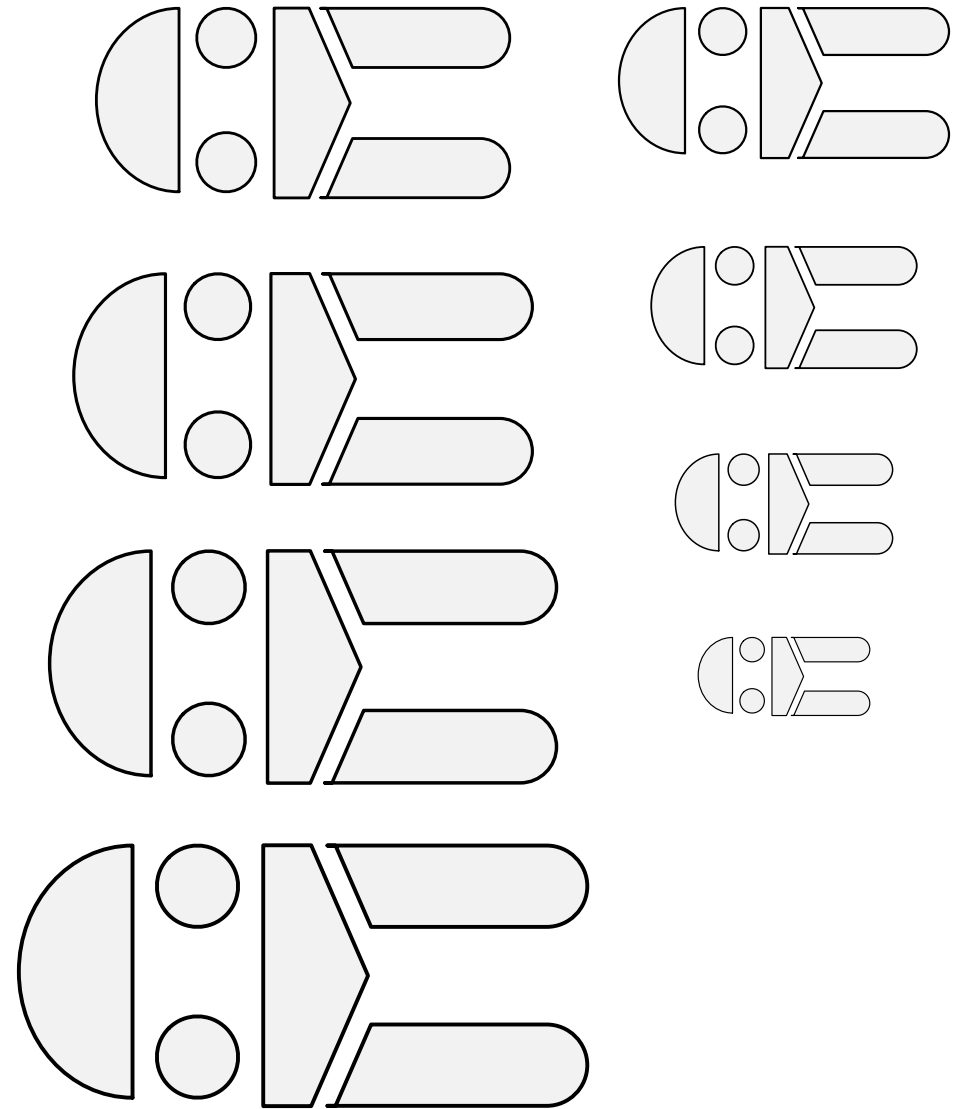
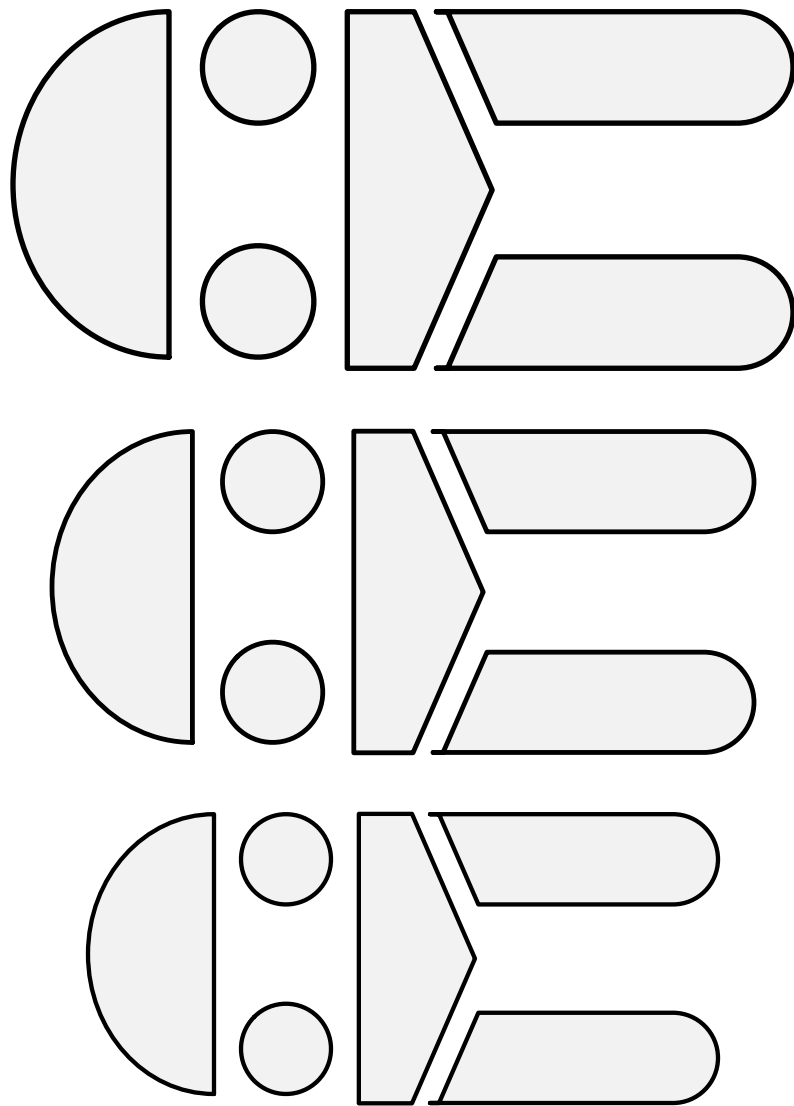

A stylized container with multiple sections for writing implements and accessories, originating in Islamic heraldry.

Default orientation: fesswise. No proper coloration.

Source: Mamluk Emblems Online Corpus. Artist unknown.

(Adapted from a photograph of the facade of a ruined house in Aleppo, dated to before 1497, depicting the emblem of Qānṣūh al-Yaḥyāwī.)

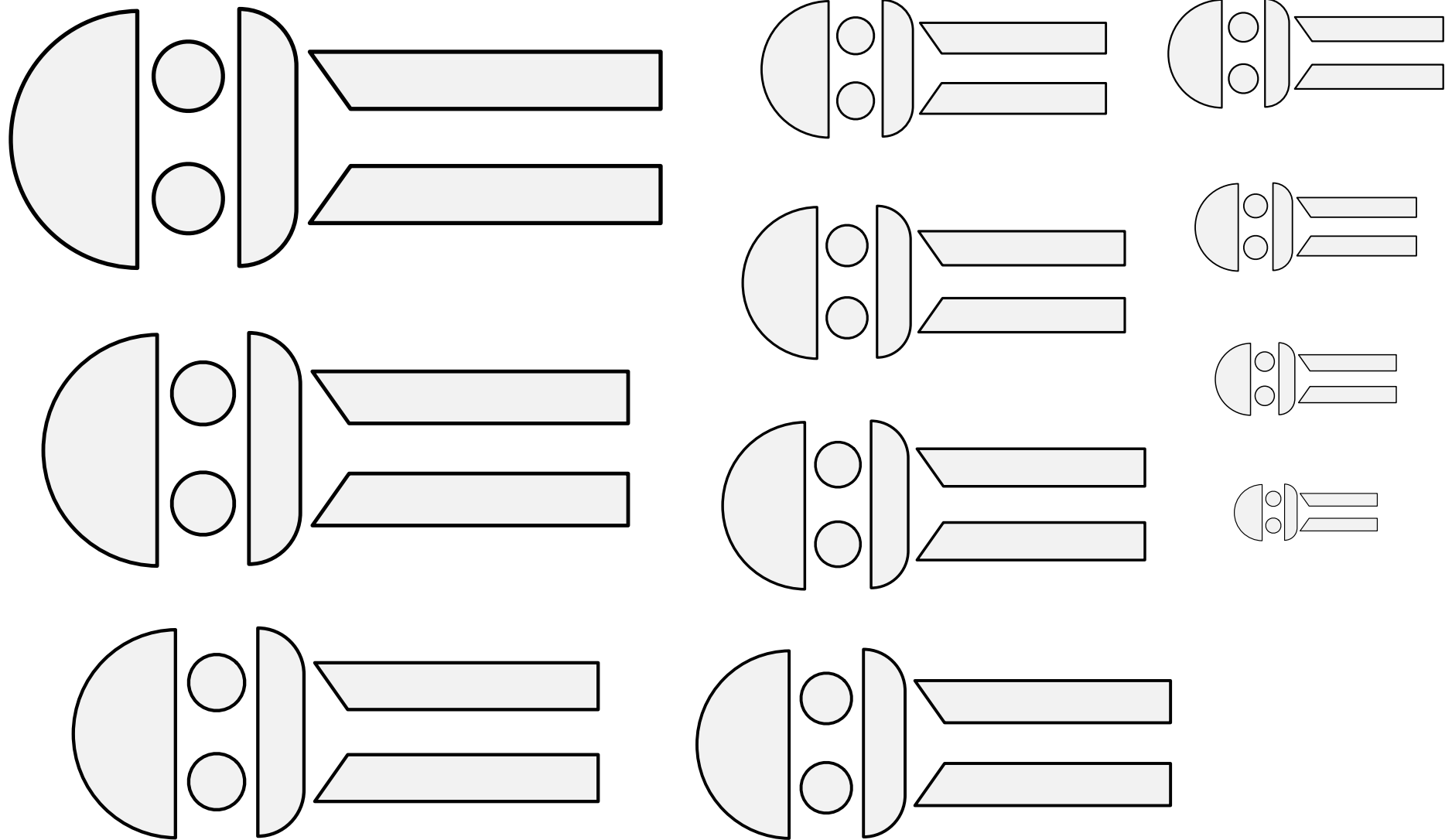

A stylized container with multiple sections for writing implements and accessories, originating in Islamic heraldry.

Default orientation: fesswise. No proper coloration.

Source: Mamluk Emblems Online Corpus. Artist unknown.

(Adapted from a photograph of the Caravanserai of Yūnus al-Dawādār in Gaza City, Palestine, dated to 1387, depicting the emblem of Amir Yunis Ibn ‘Abdallah al-Nawruzi.)

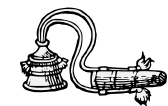
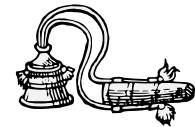
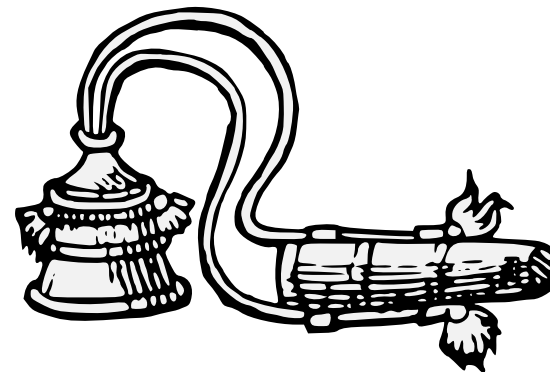
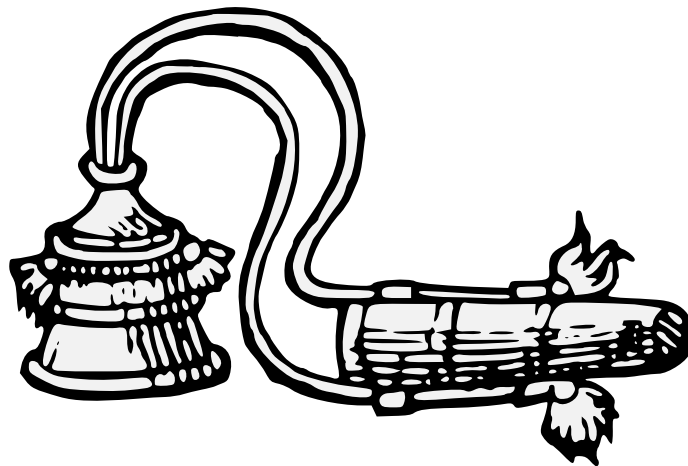
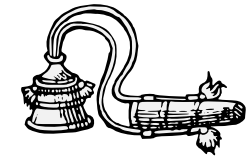
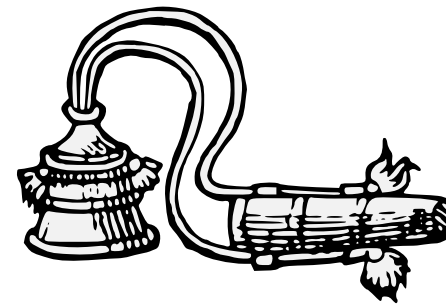
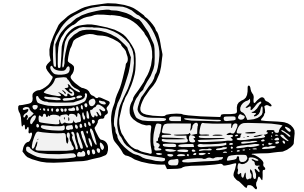
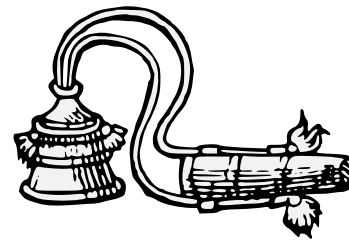
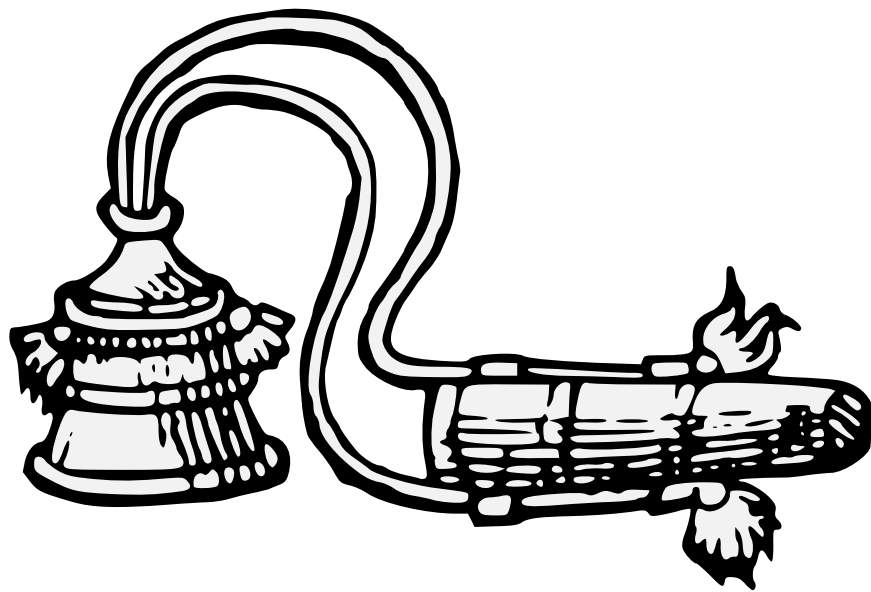

A pen case and attached inkhorn.

No default orientation. No proper coloration.

Source: Guillim's Display of Heraldry. Artist unknown.

Penner and Inkhorn 18.158

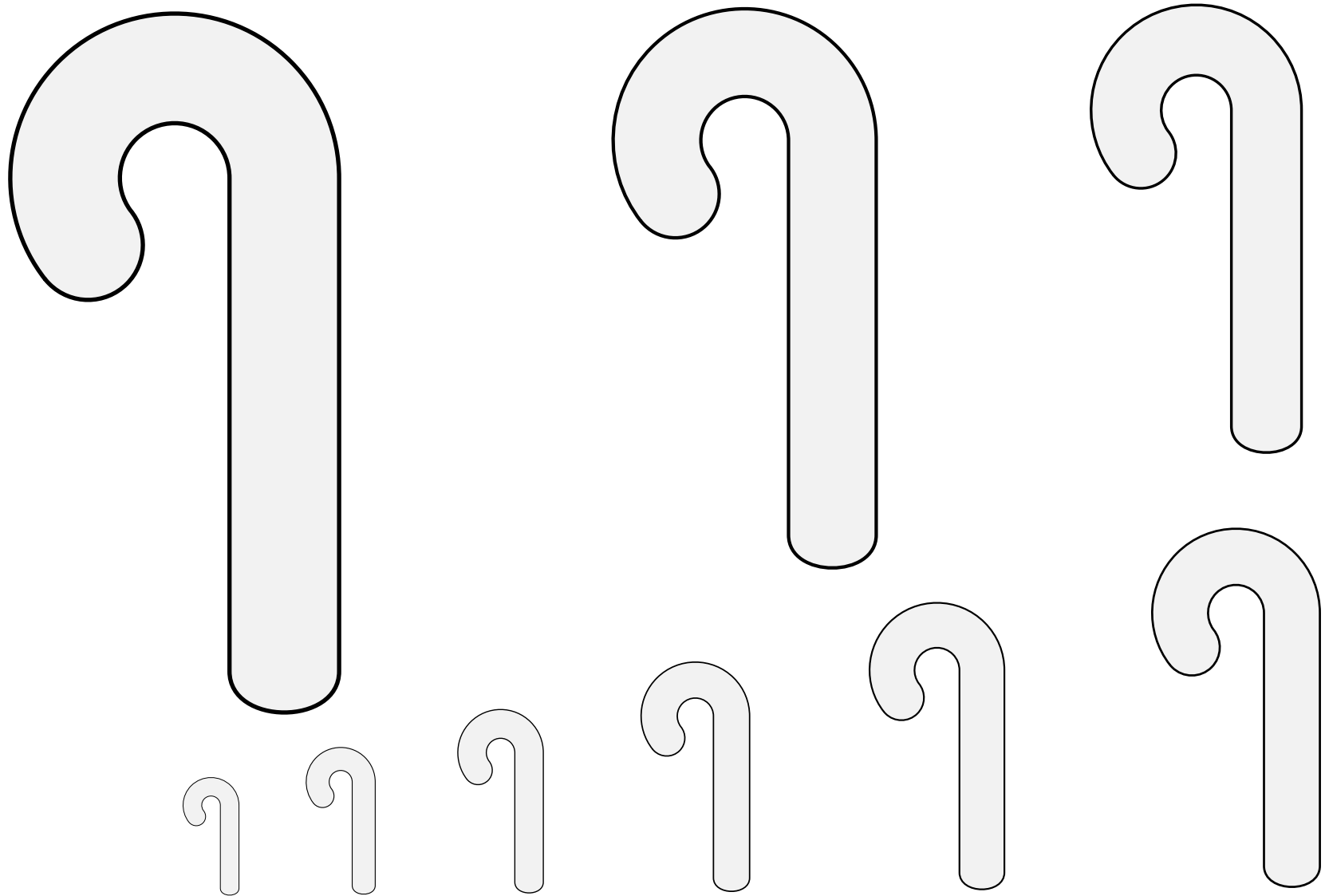

A wooden staff with a curved end used to strike a ball. Found in Islamic heraldry.

Default orientation: curved end to chief. No proper coloration.

Source: Mamluk Emblems Online Corpus. Artist unknown.

(Adapted from a photograph of a ceramic fragment with polo sticks, dated c. 1300 conserved at the Museum of Islamic Art, Cairo.)

Polo Stick 18.159

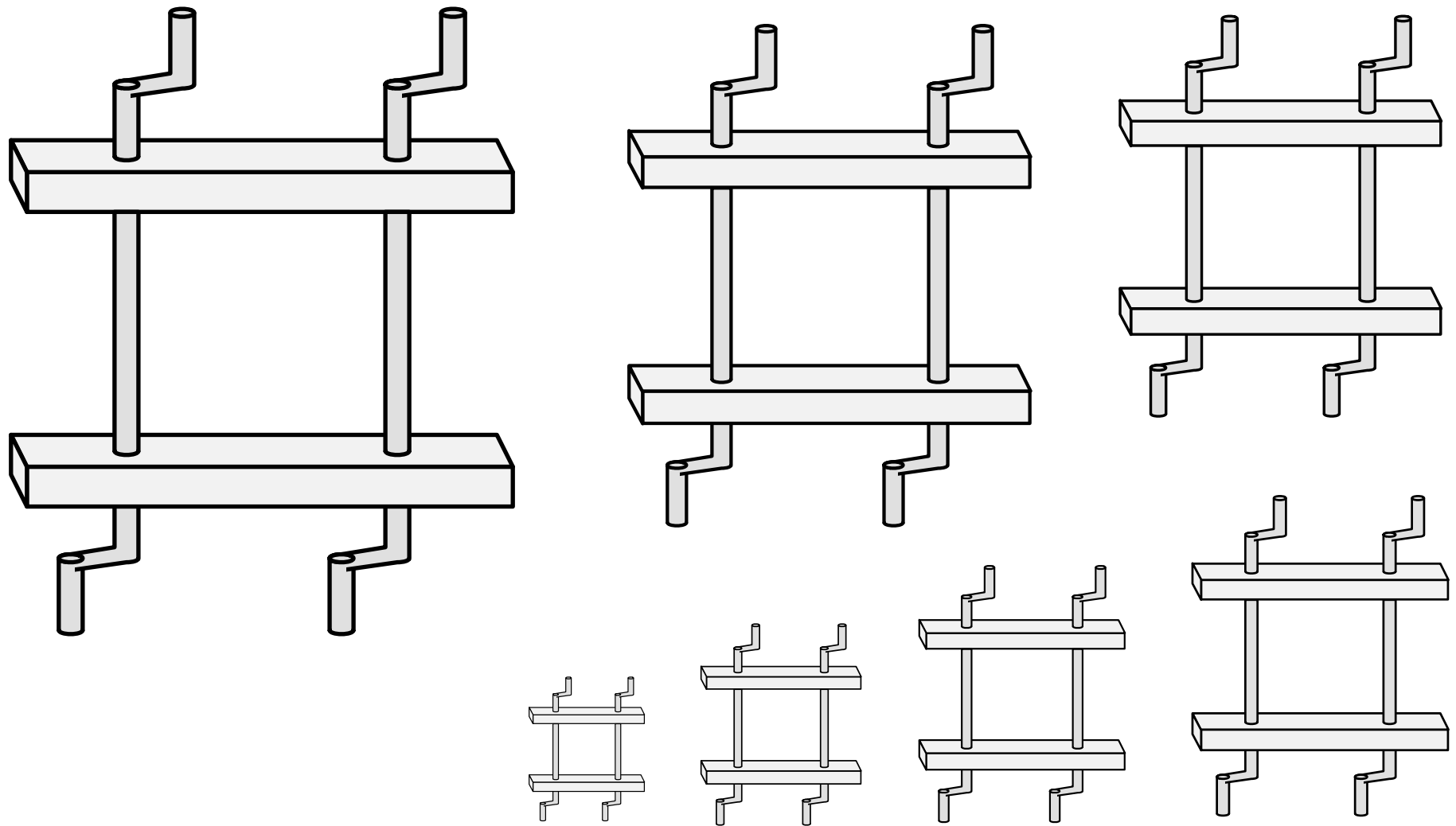

A contraption for squeezing items together.
Default orientation: shafts palewise. No proper coloration.
Source: Flandria Roll. Artist unknown. (Folio 72r.)

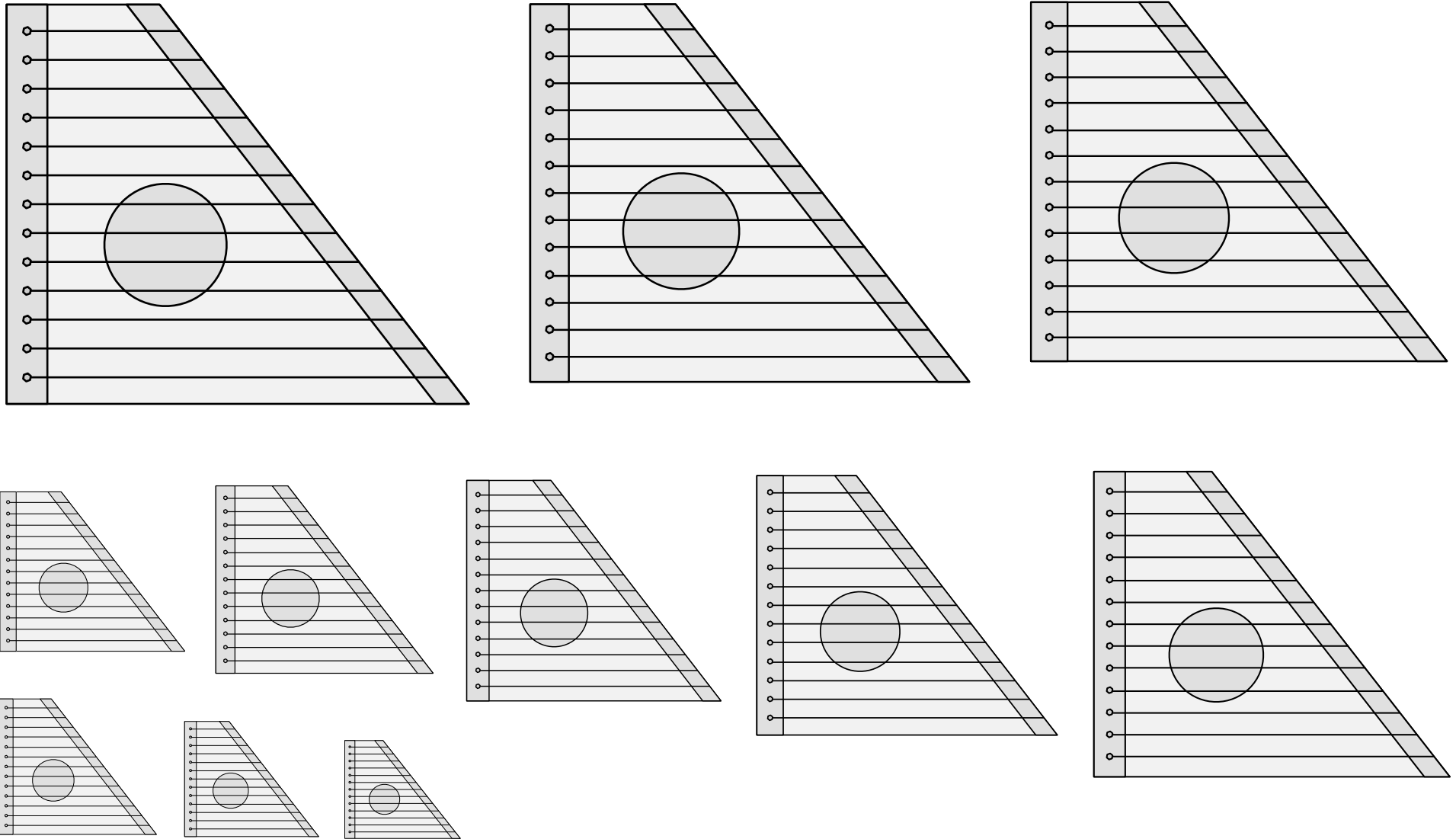

A Renaissance-era string instrument, played by plucking the strings.
Default orientation: unknown. No proper coloration.

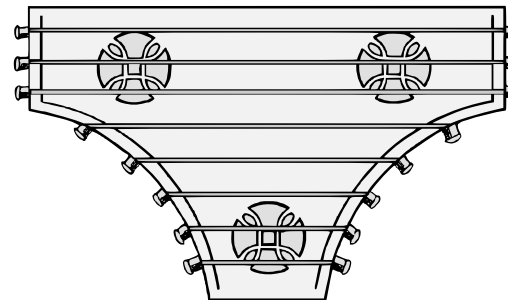
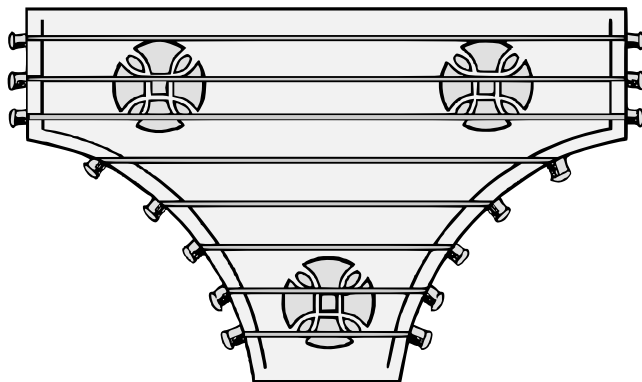
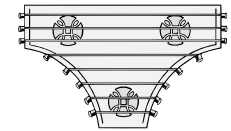
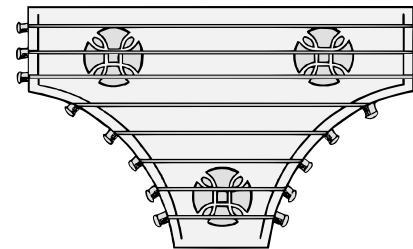
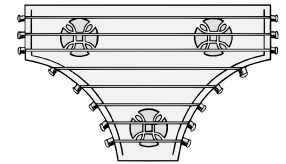
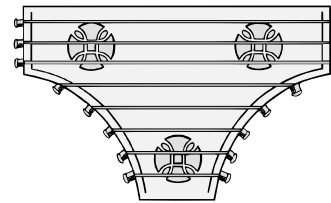
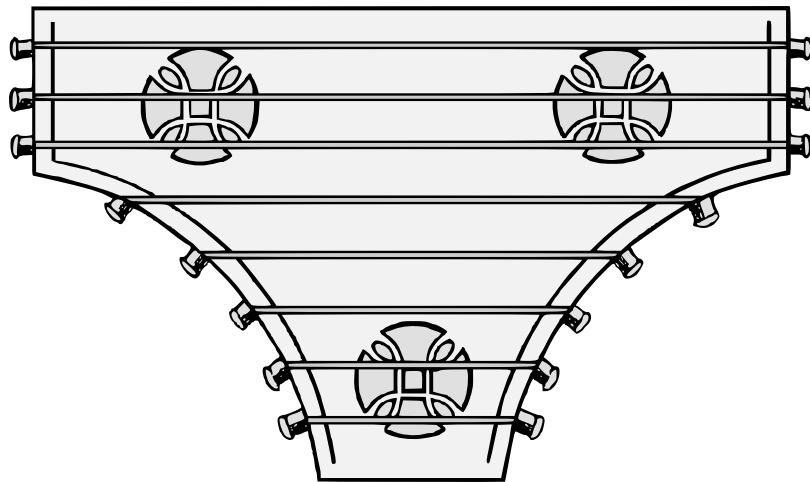

A Renaissance-era string instrument, played by plucking the strings.

Default orientation: unknown. No proper coloration.

Artist: Jessimond of Emerickeskepe.

Psaltery, Pig-Snouted 18.162

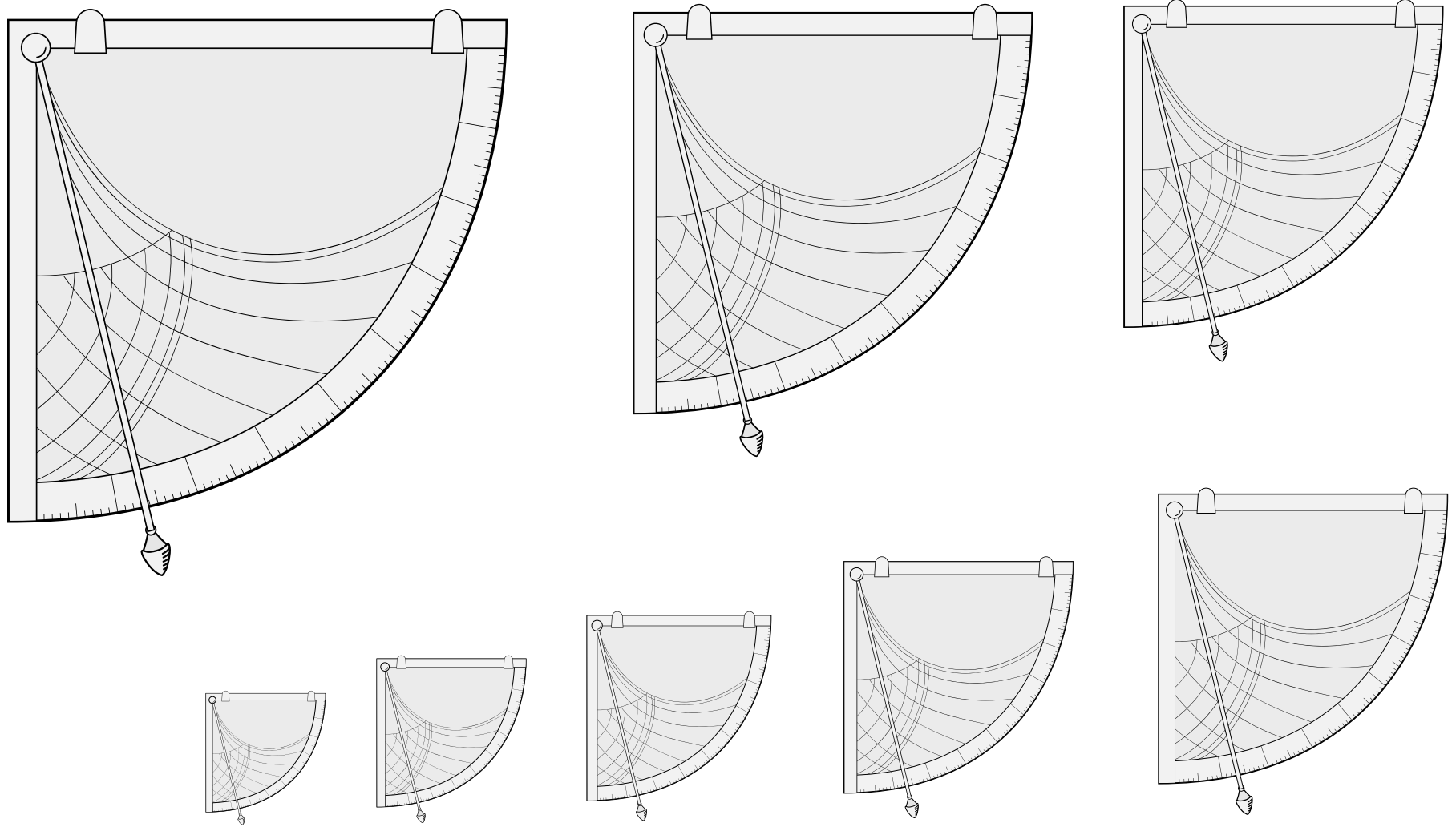

A tool for measuring angles used in astronomy and engineering.

Default orientation: arm pendant to base. No proper coloration.

Source: Pictorial Dictionary of Heraldry. Artist: Bruce Draconarius.

Adapted by Saewynn aet Cnolle.

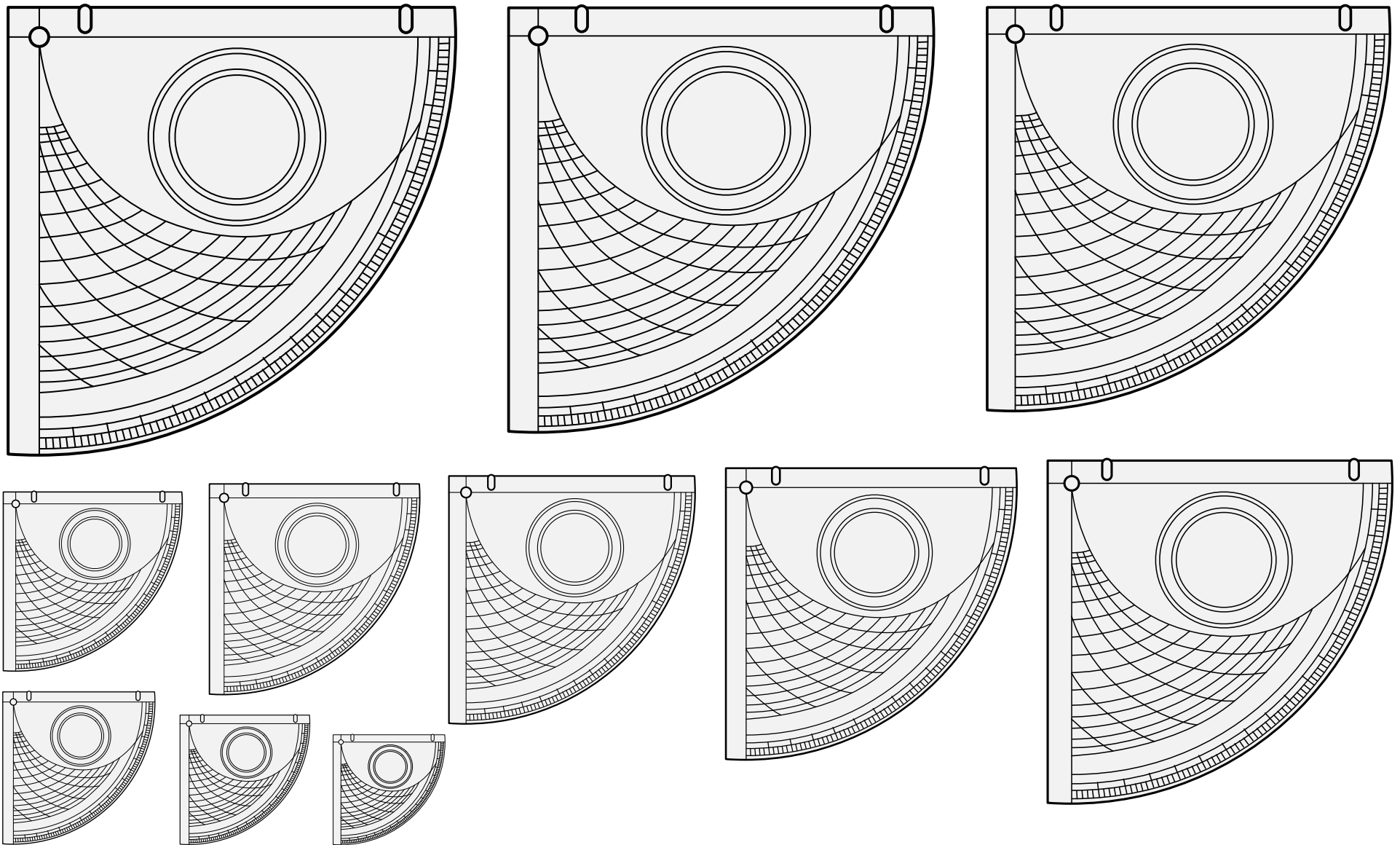

A tool for measuring angles used in astronomy and engineering.

Default orientation: arm pendant to base. No proper coloration.

Source: British Museum. (Accession 1860,0519.1; circa 1400.) Artist unknown.

Quadrant (2) 18.164

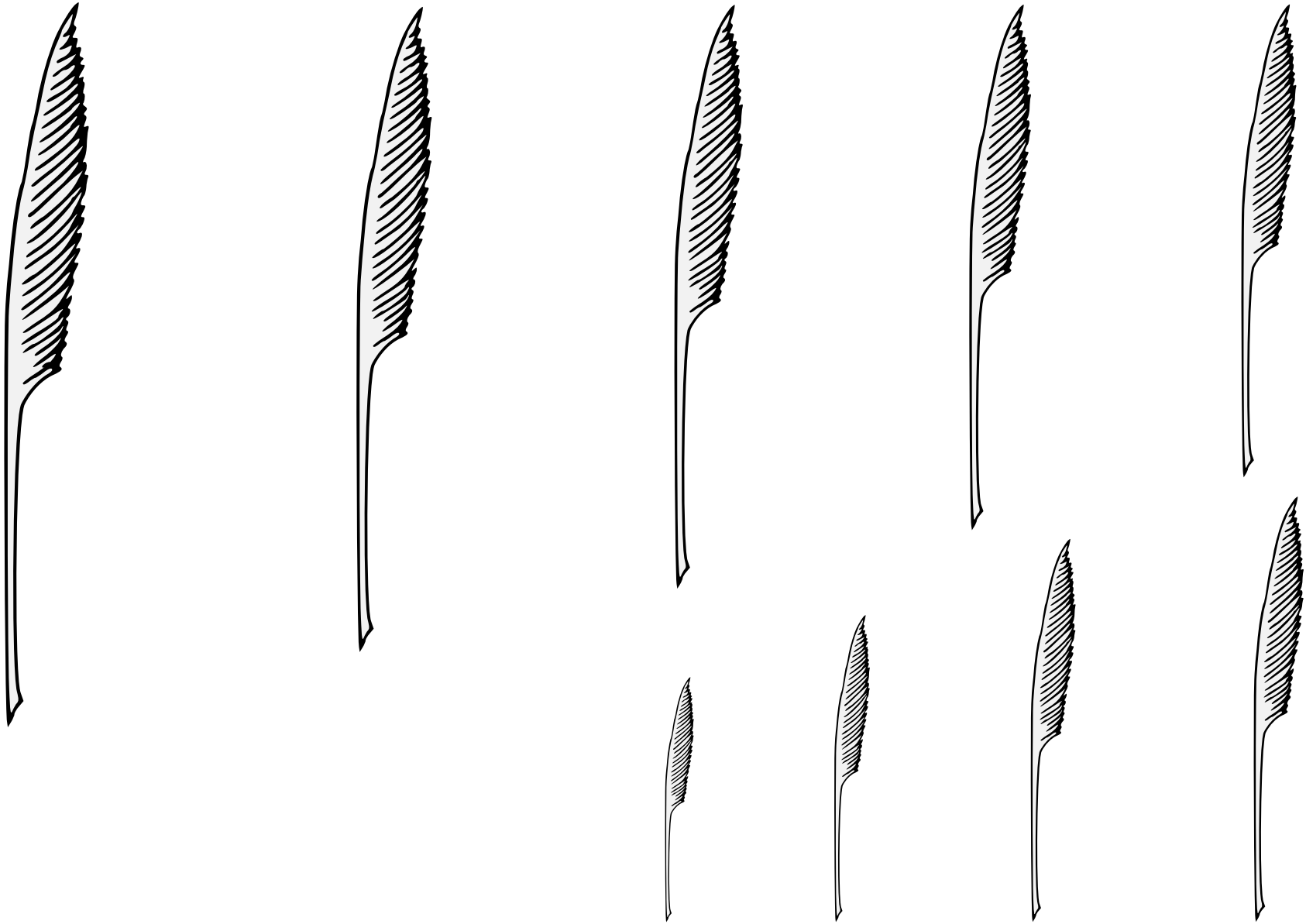

A bird's feather, trimmed to allow use as a writing implement.

Default orientation: palewise, point to base.

Source: Pennsic Traceable Art. Artist unknown.

Adapted by Mathghamhain Ua Ruadháin.

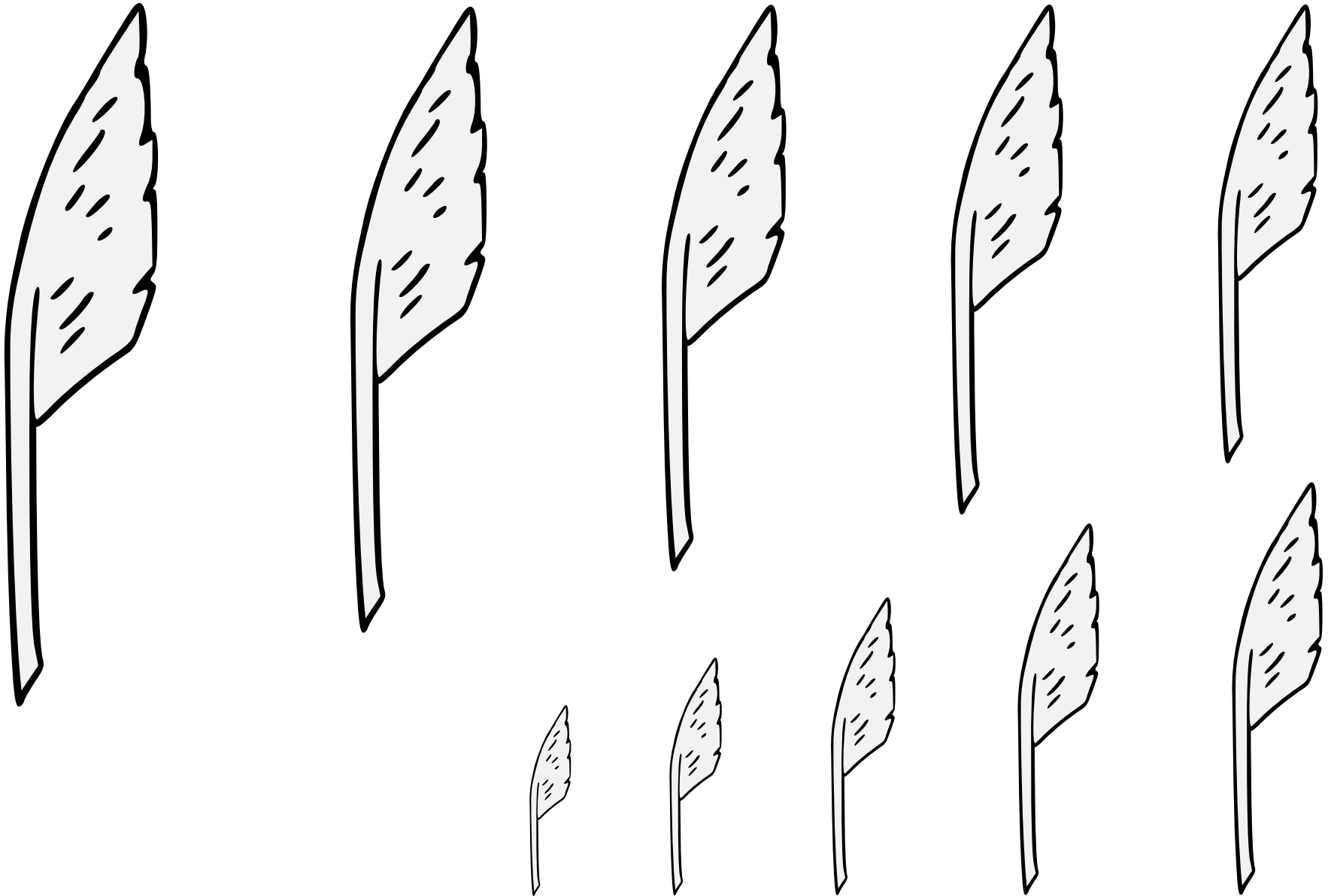

A bird's feather, trimmed to allow use as a writing implement.

Default orientation: palewise, point to base.

Source: Pennsic Traceable Art. Artist unknown.

Adapted by Mathghamhain Ua Ruadháin.

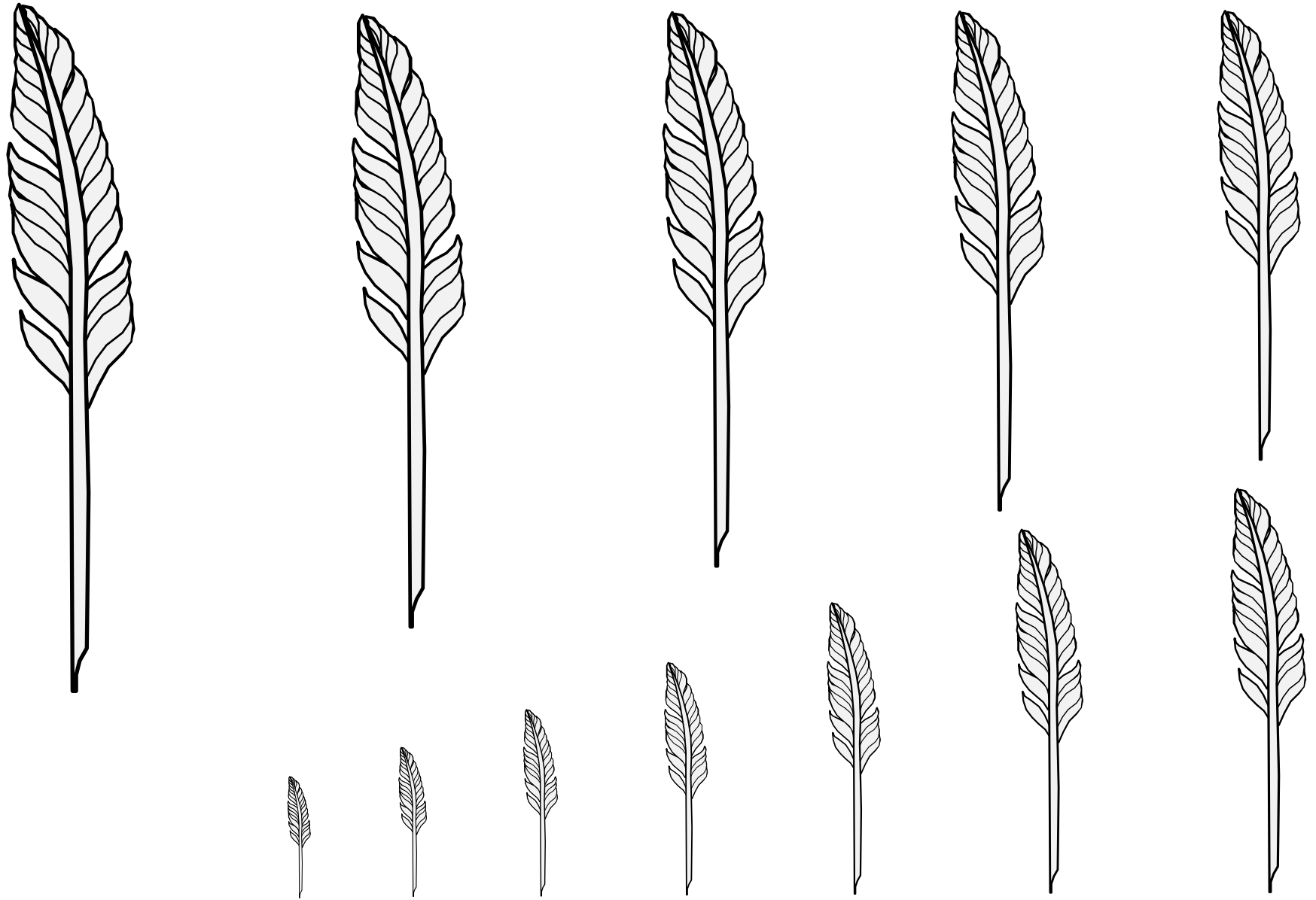

A bird's feather, trimmed to allow use as a writing implement.

Default orientation: palewise, point to base. No proper coloration.

Source: Viking Answer Lady SVG Images For Heraldists. Artist: Gunnvôr silfráhr.

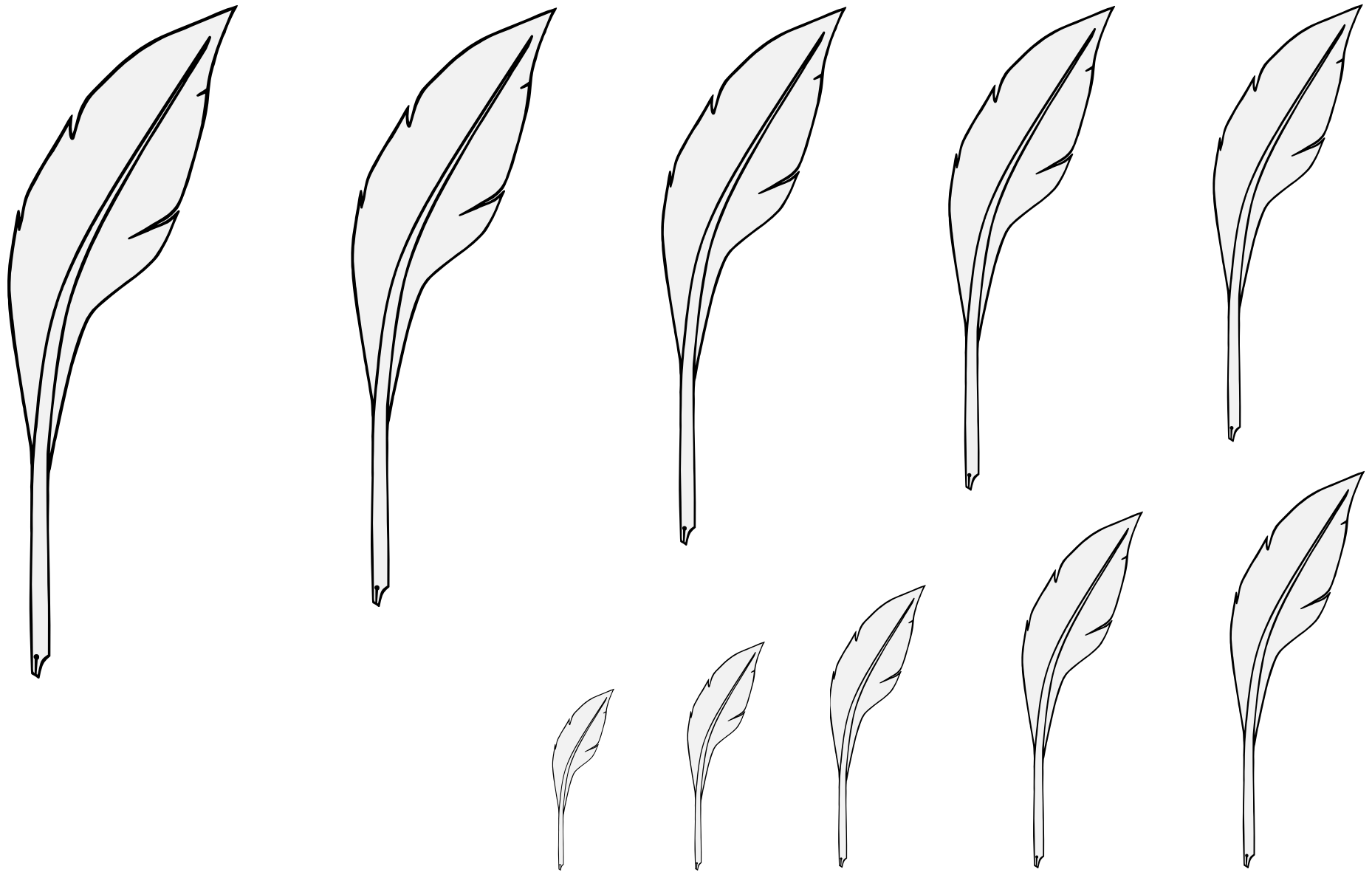

A bird's feather, trimmed to allow use as a writing implement.
Default orientation: palewise, point to base. No proper coloration.
Artist: Jessimond of Emerickeskepe.

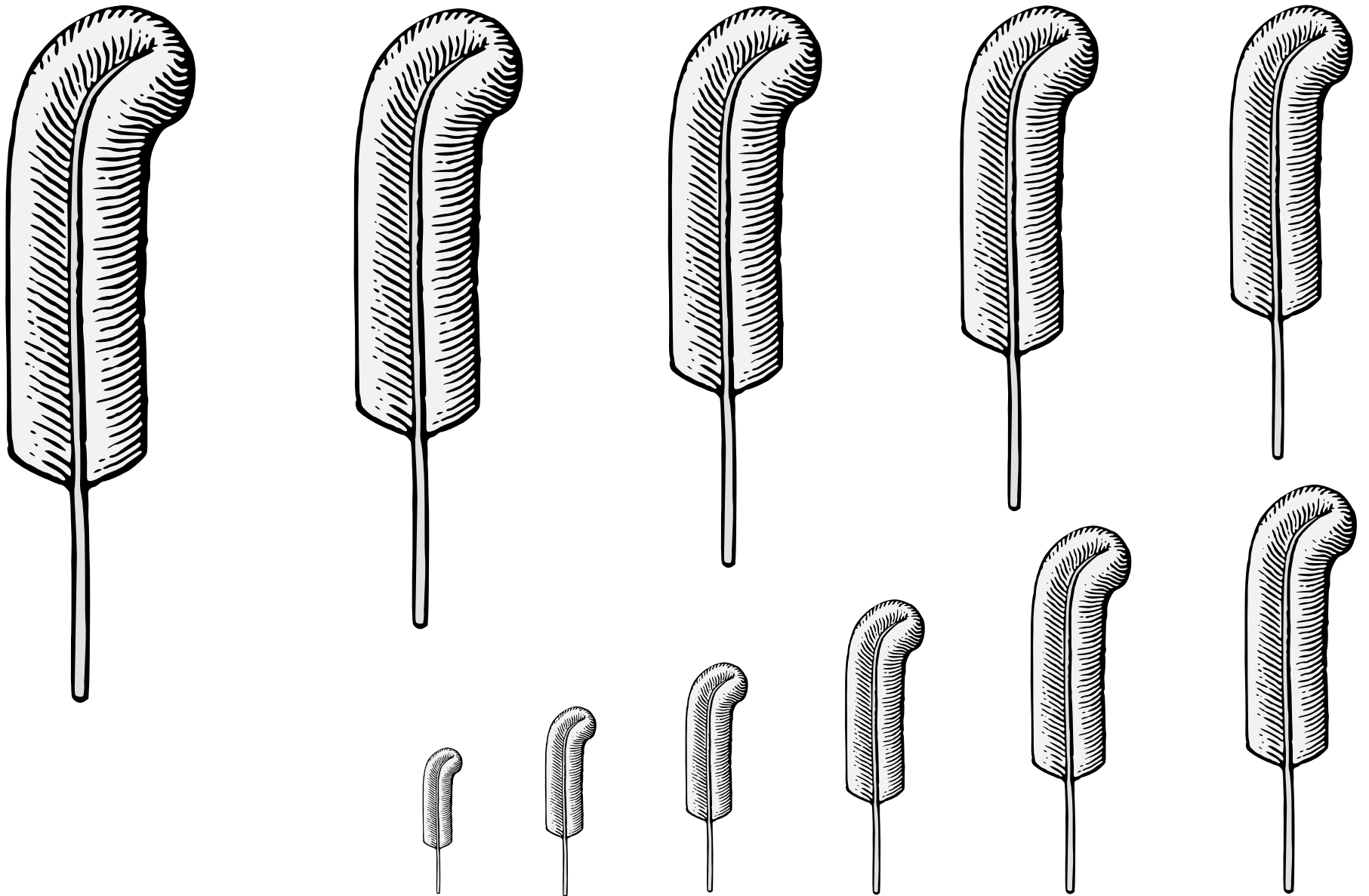

The plumage of a bird.

Default orientation: quill to base. No proper coloration.

Source: Heraldry, Ancient and Modern. Artist unknown.
(Page 307, from the seal of Edward V.)

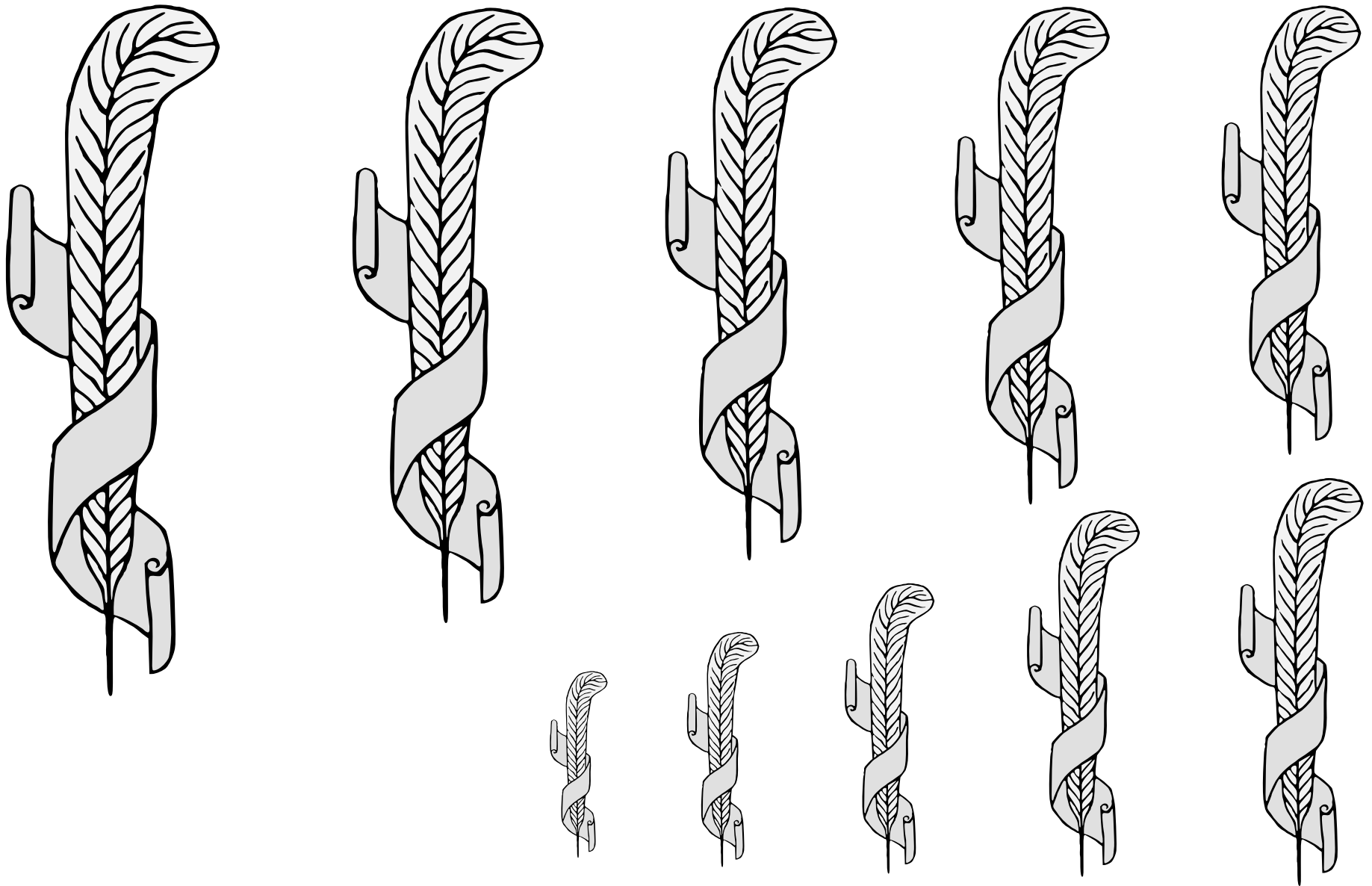

A small piece of parchment, which always appears with another charge piercing it.

No default orientation. No proper coloration.

Source: Two Tudor Books of Arms.

Artist: Robert Cooke. (Page 144.)

Quill Pen Entwined by an Escroll 18.170

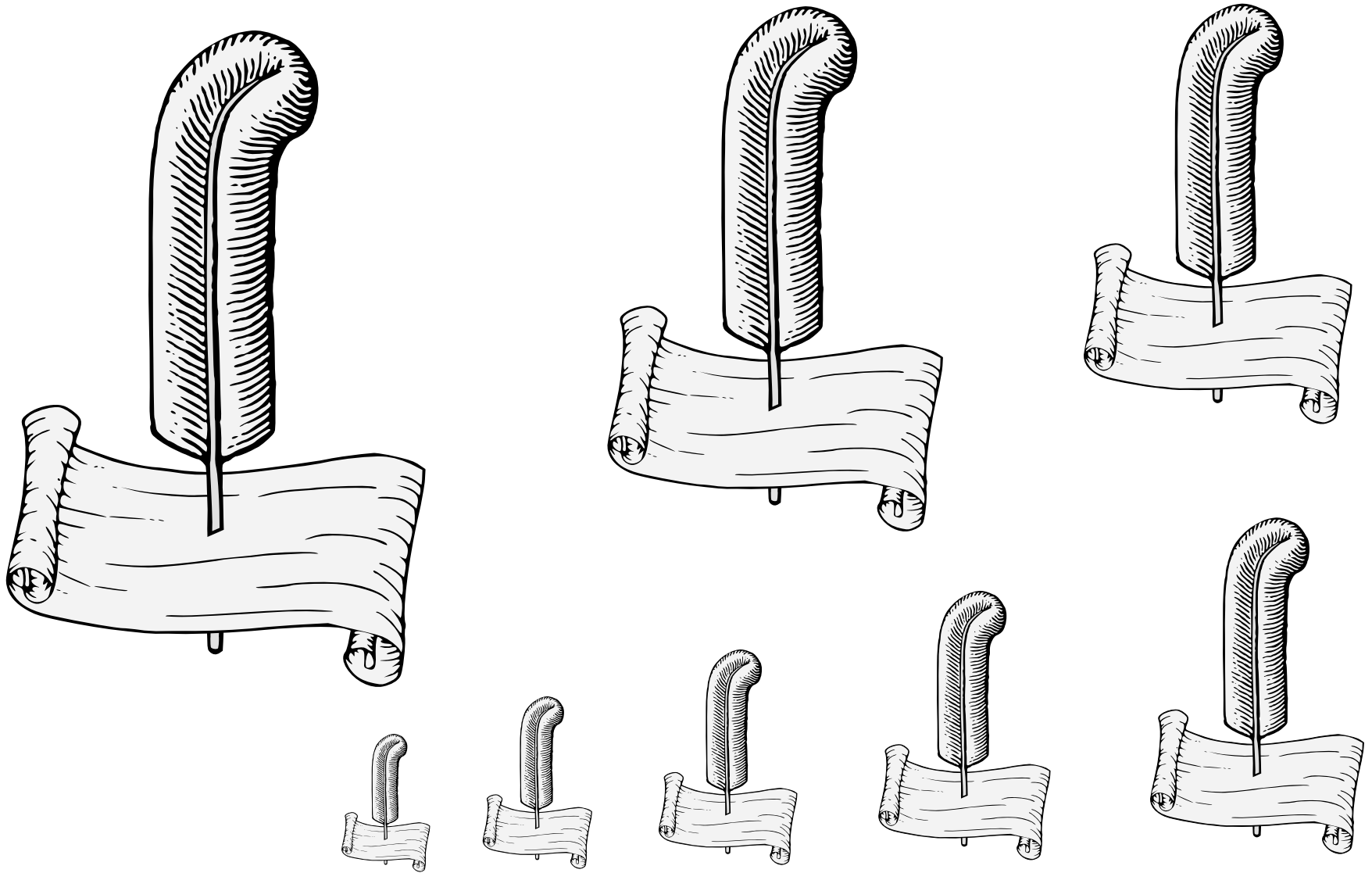

A small piece of parchment, which always appears with another charge piercing it.
Adapted from an image of a scroll and of a feather, both elsewhere in this collection.

Quill Pen Transfixing an Escroll Fesswise (1) 18.171

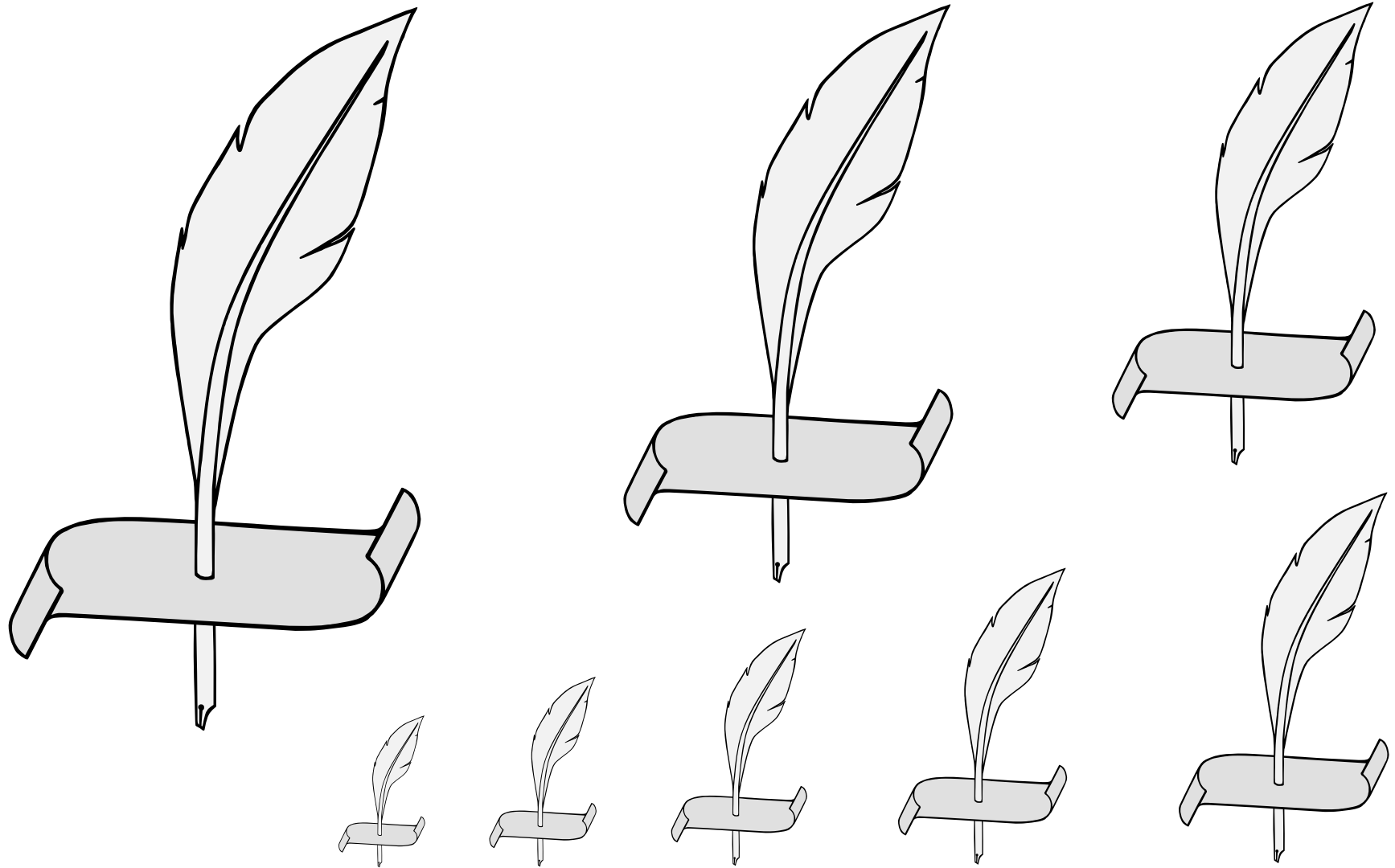

A small piece of parchment, which always appears with another charge piercing it.

No default orientation. No proper coloration.

Artist: Jessimond of Emerickeskepe.

Quill Pen Transfixing an Escroll Fesswise (2) 18.172

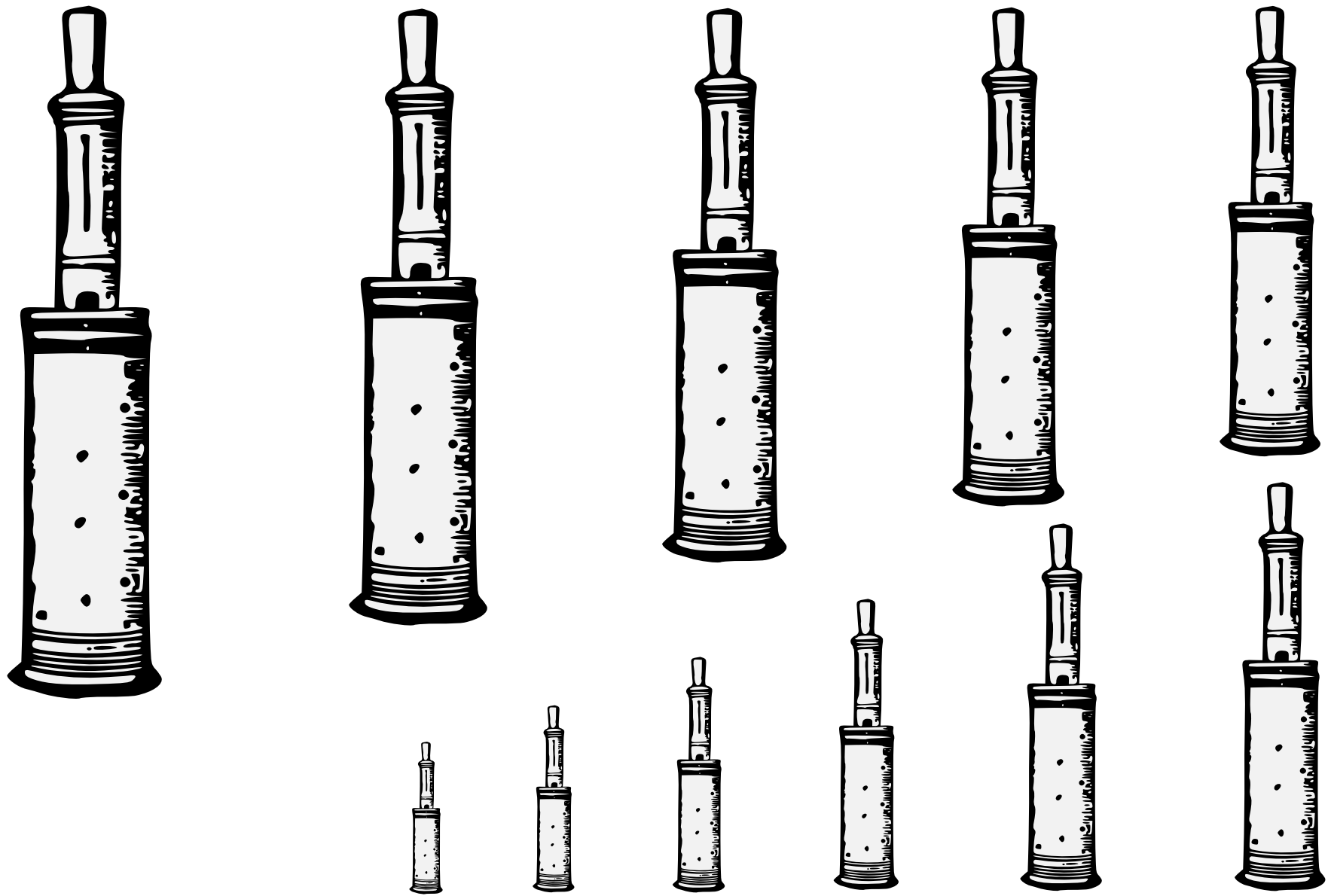

A sixteenth-century base wind instrument.

Default orientation: mouthpiece to chief. No proper coloration.

Source: Encyclopædia Britannica. (11th edition, 1911, Vol. 22, p. 780.) Artist unknown.

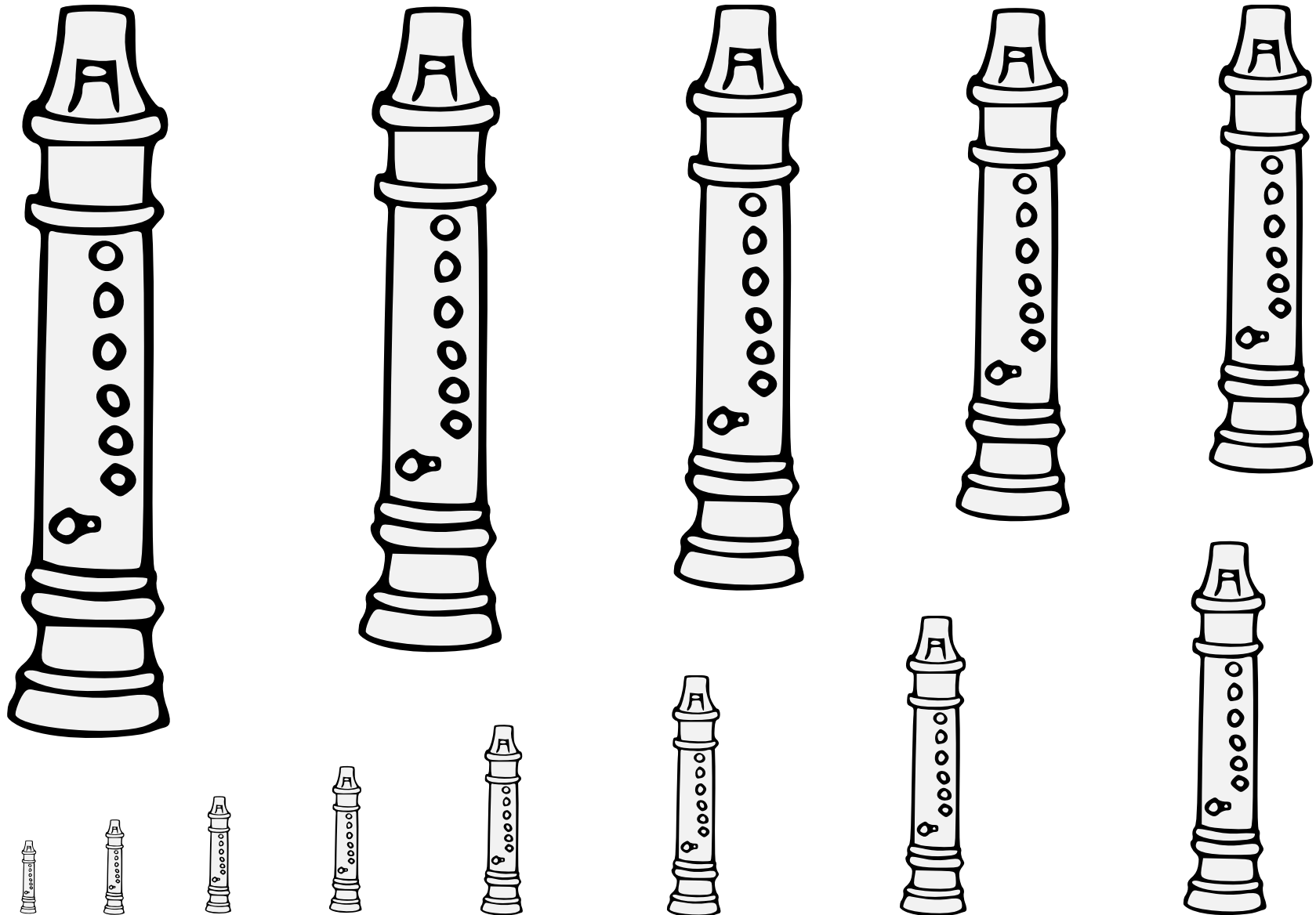

A classic wind instrument constructed of wood.
No default orientation. No proper coloration.
Source: Pennsic Traceable Art. Artist unknown.

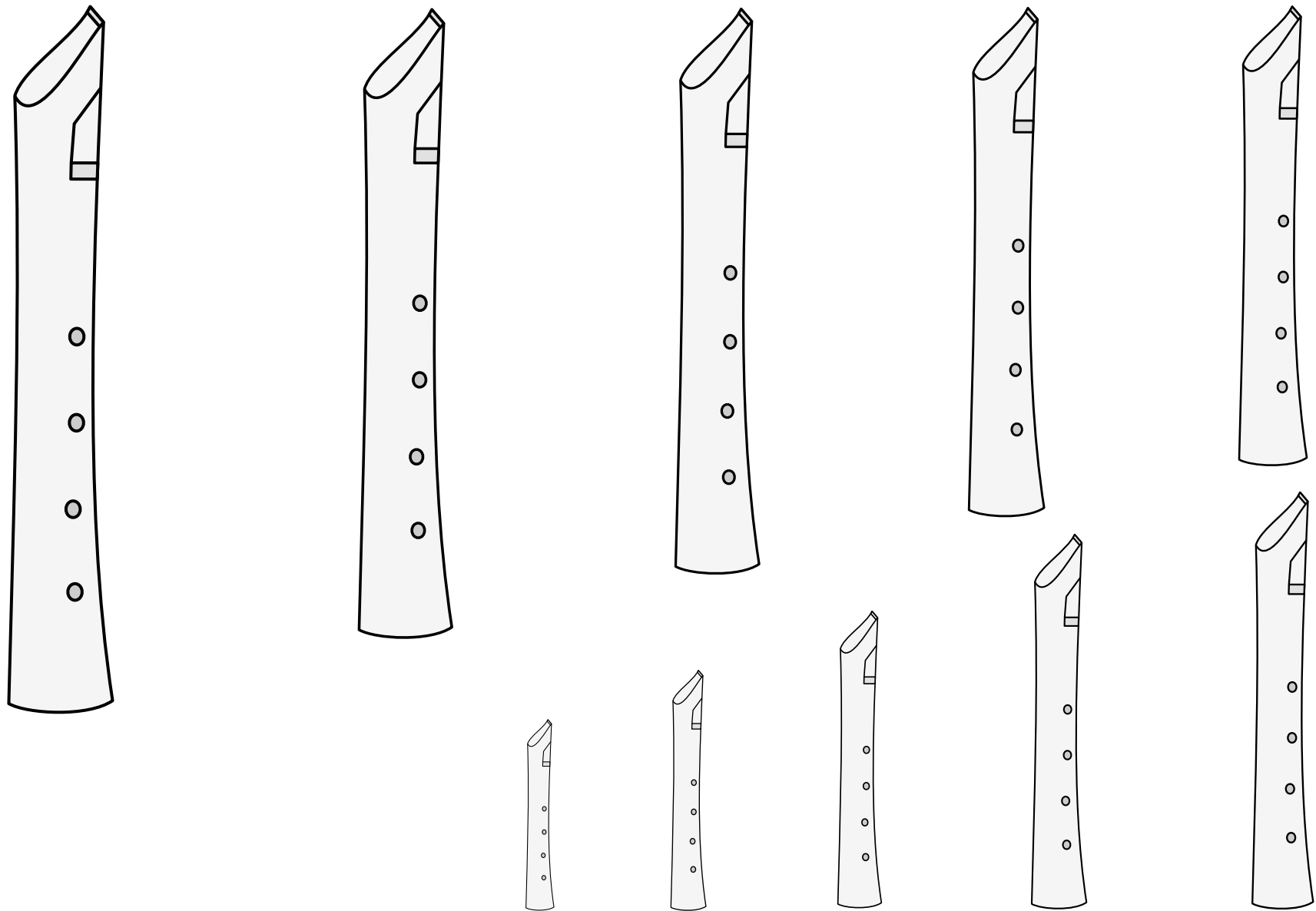

A classic wind instrument constructed of wood.

No default orientation. No proper coloration.

Source: Austrian State Archives. (Entry AT-OeStA/AVA Adel HAA AR 912.36.)

Artist unknown. Adapted by Iago ab Adam.

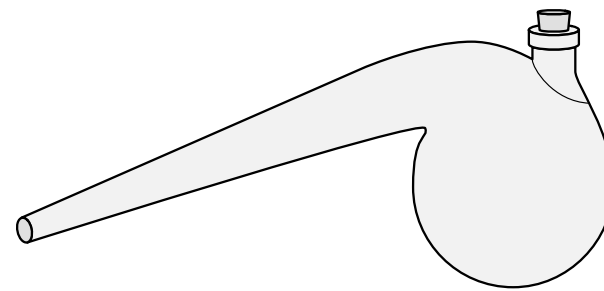
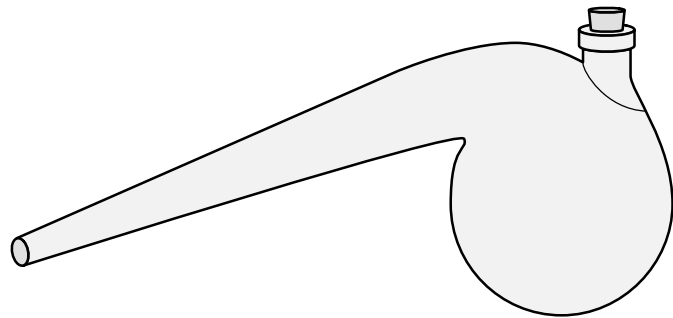
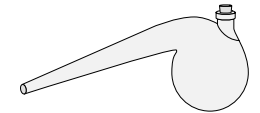
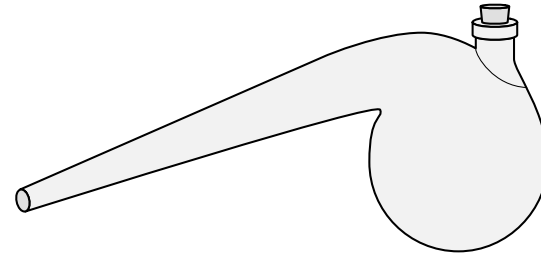
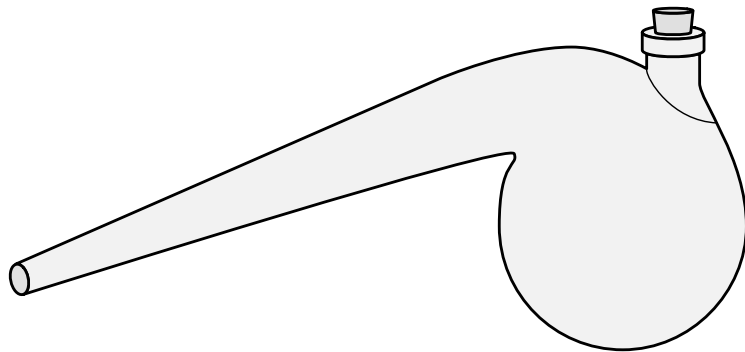
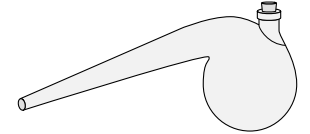
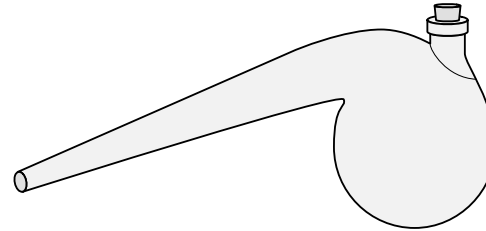
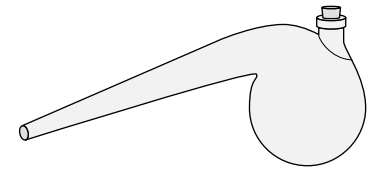
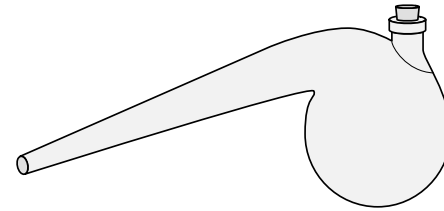
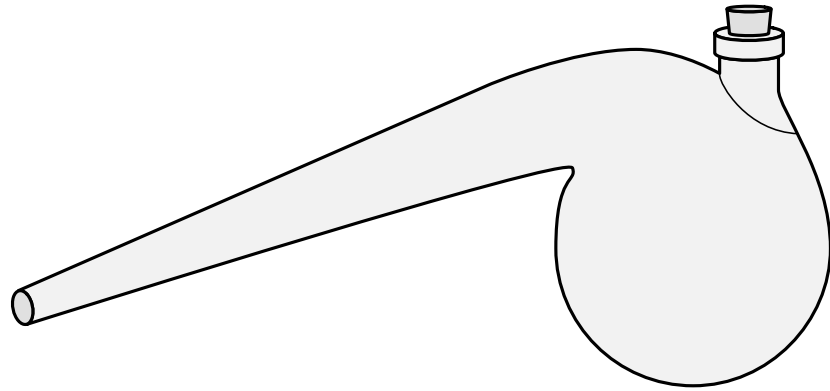

A glass container used for heating liquids and collecting their distillates.
Default orientation: outlet to dexter. No proper coloration.

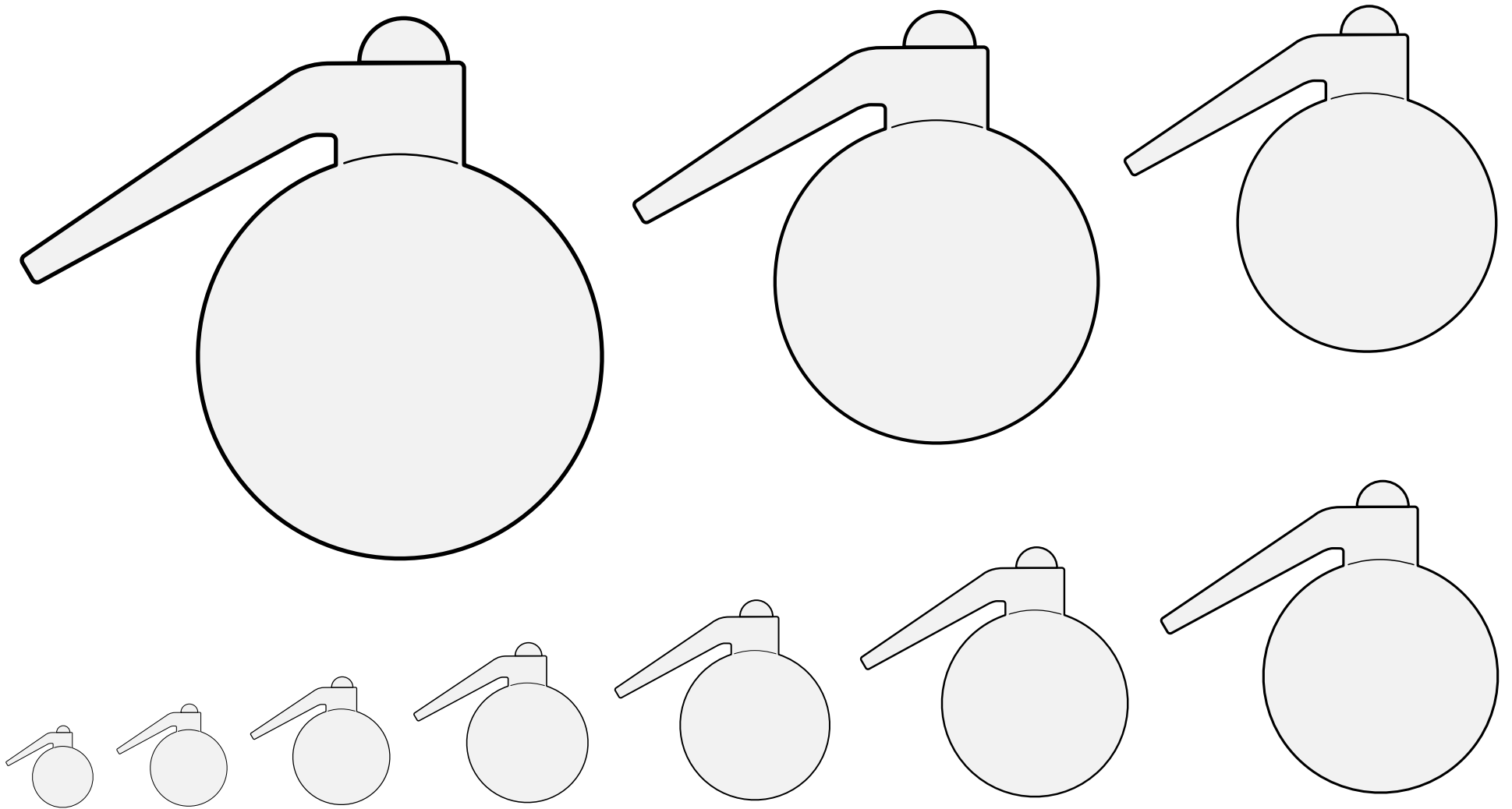

A glass container used for heating liquids and collecting their distillates.
Default orientation: outlet to dexter. No proper coloration.

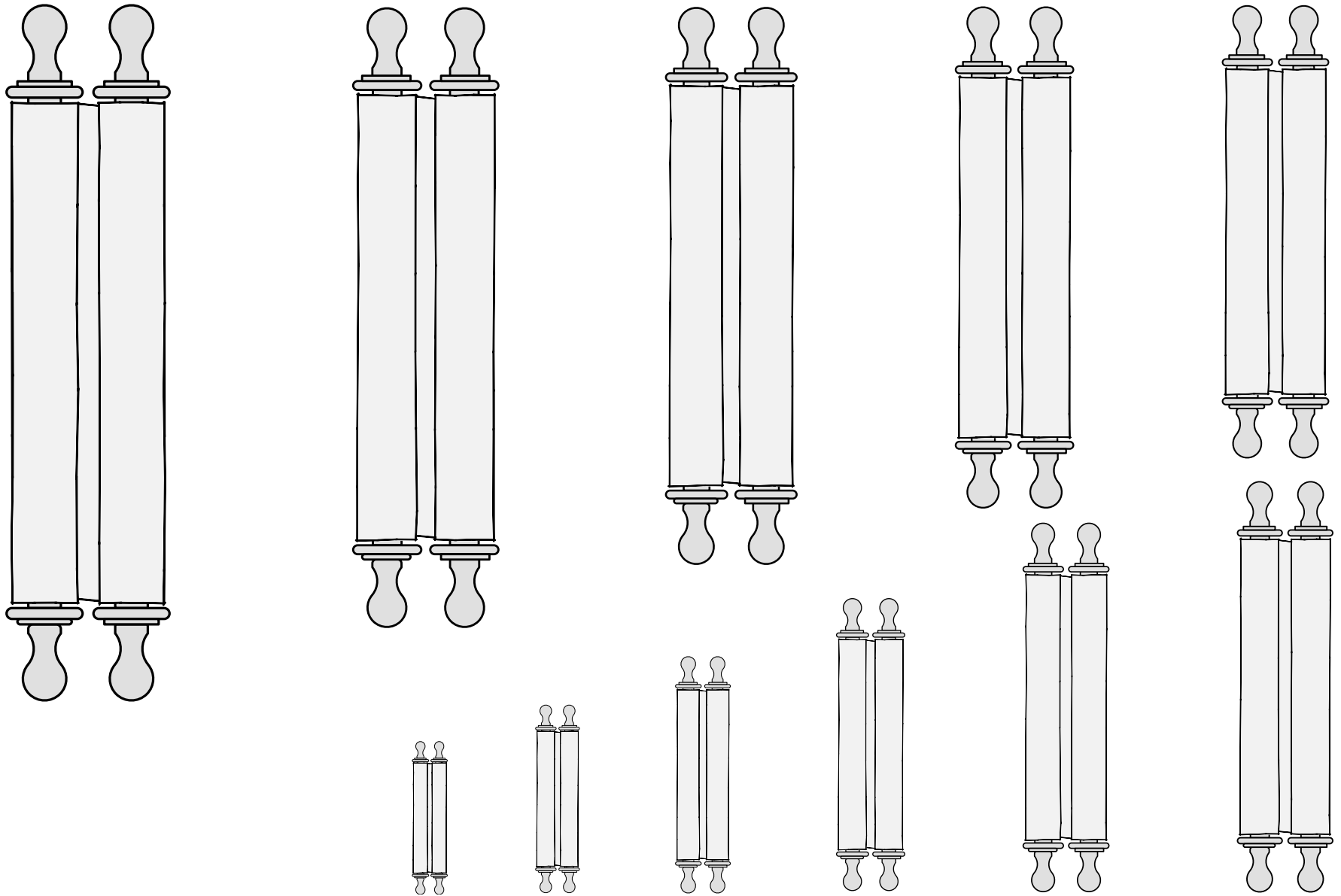

A rolled document, sometimes wrapped around wooden shafts.
Default orientation: palewise.

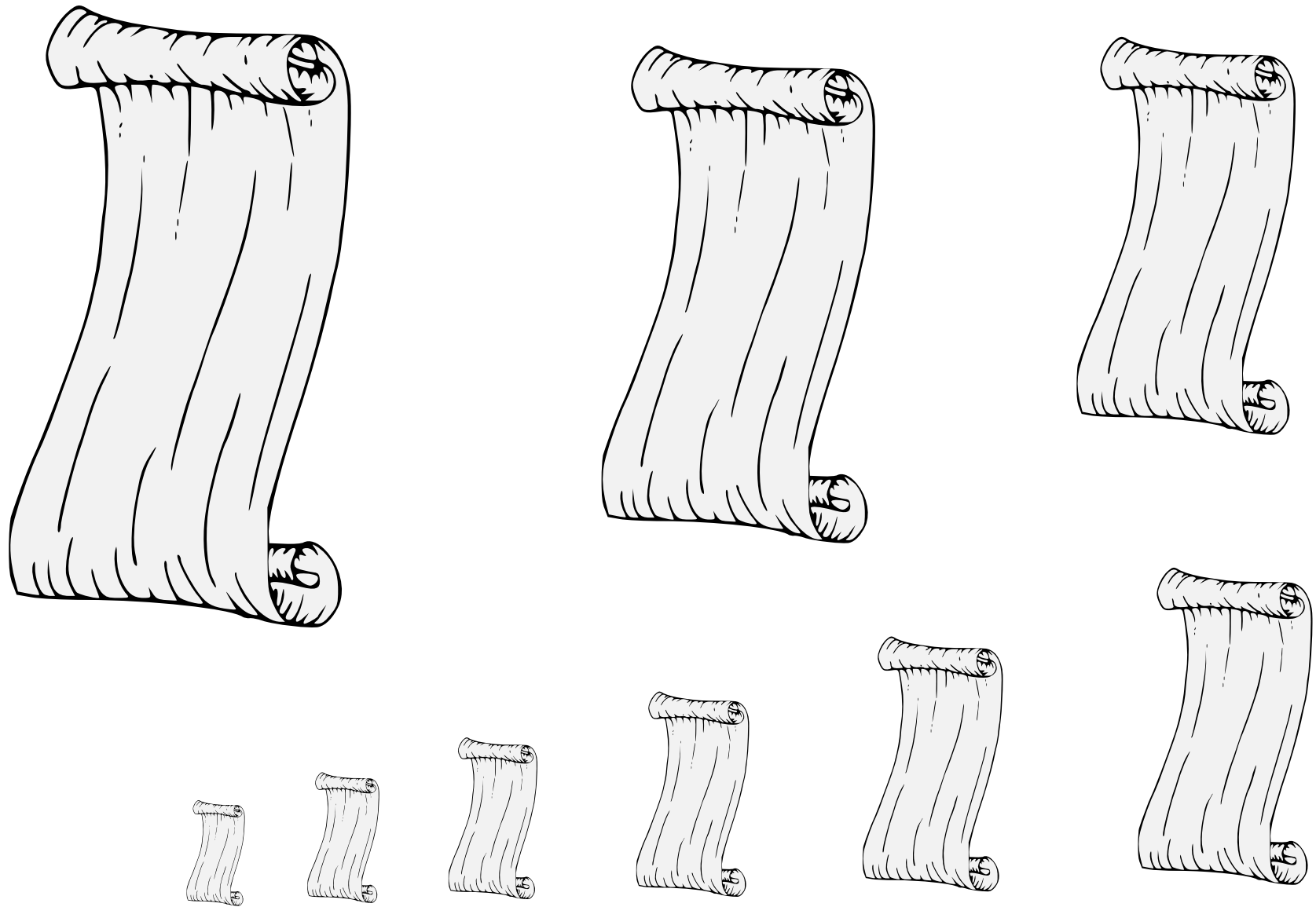

A rolled document, sometimes wrapped around wooden shafts.

An open scroll has a section exposed for reading.

No default orientation.

Source: Heraldic Templates. Artist: Torric inn Björn.

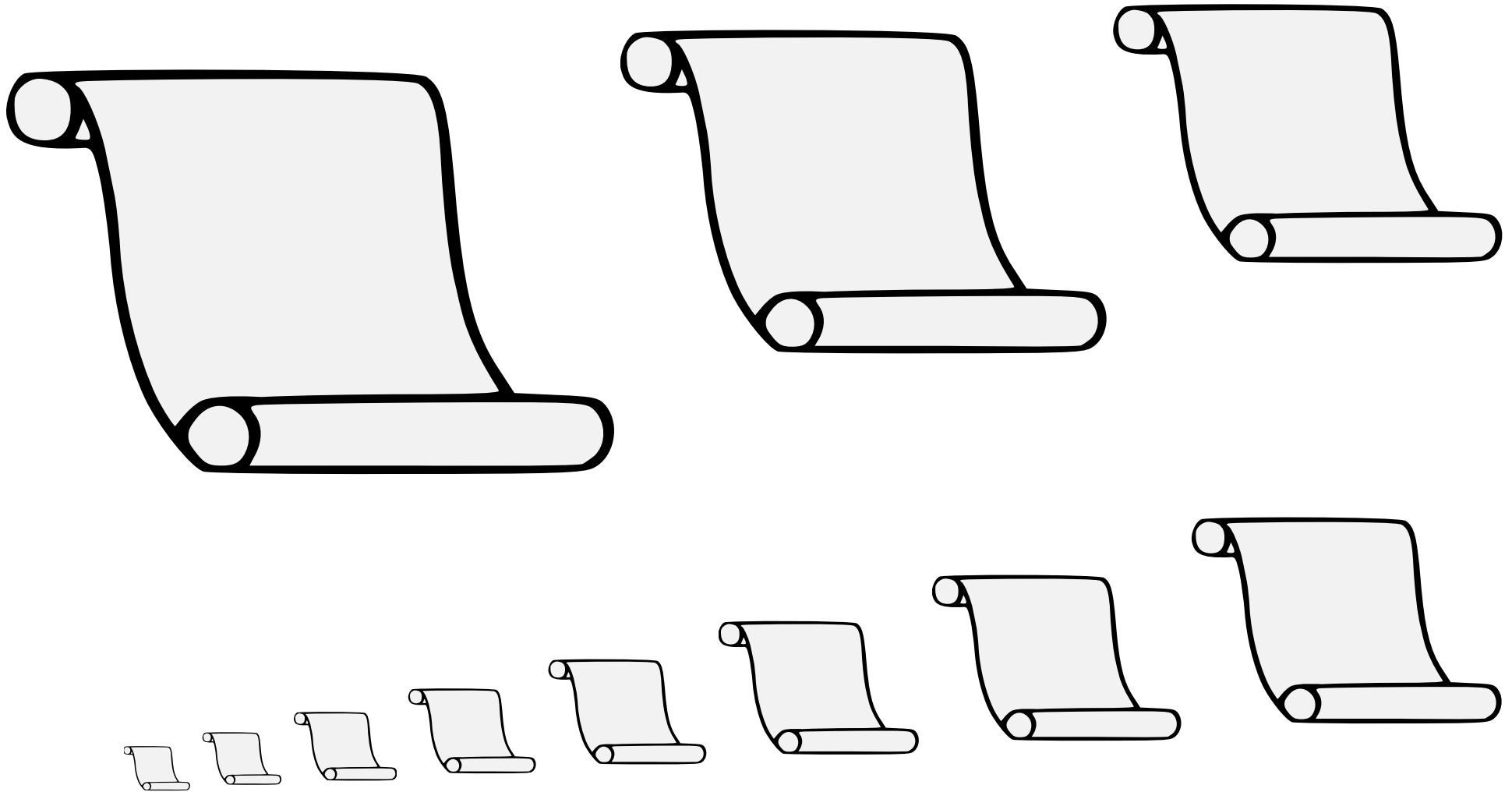

A rolled document, sometimes wrapped around wooden shafts.

An open scroll has a section exposed for reading.

No default orientation.

Source: Pennsic Traceable Art. Artist unknown.

Scroll, Open (2) 18.180

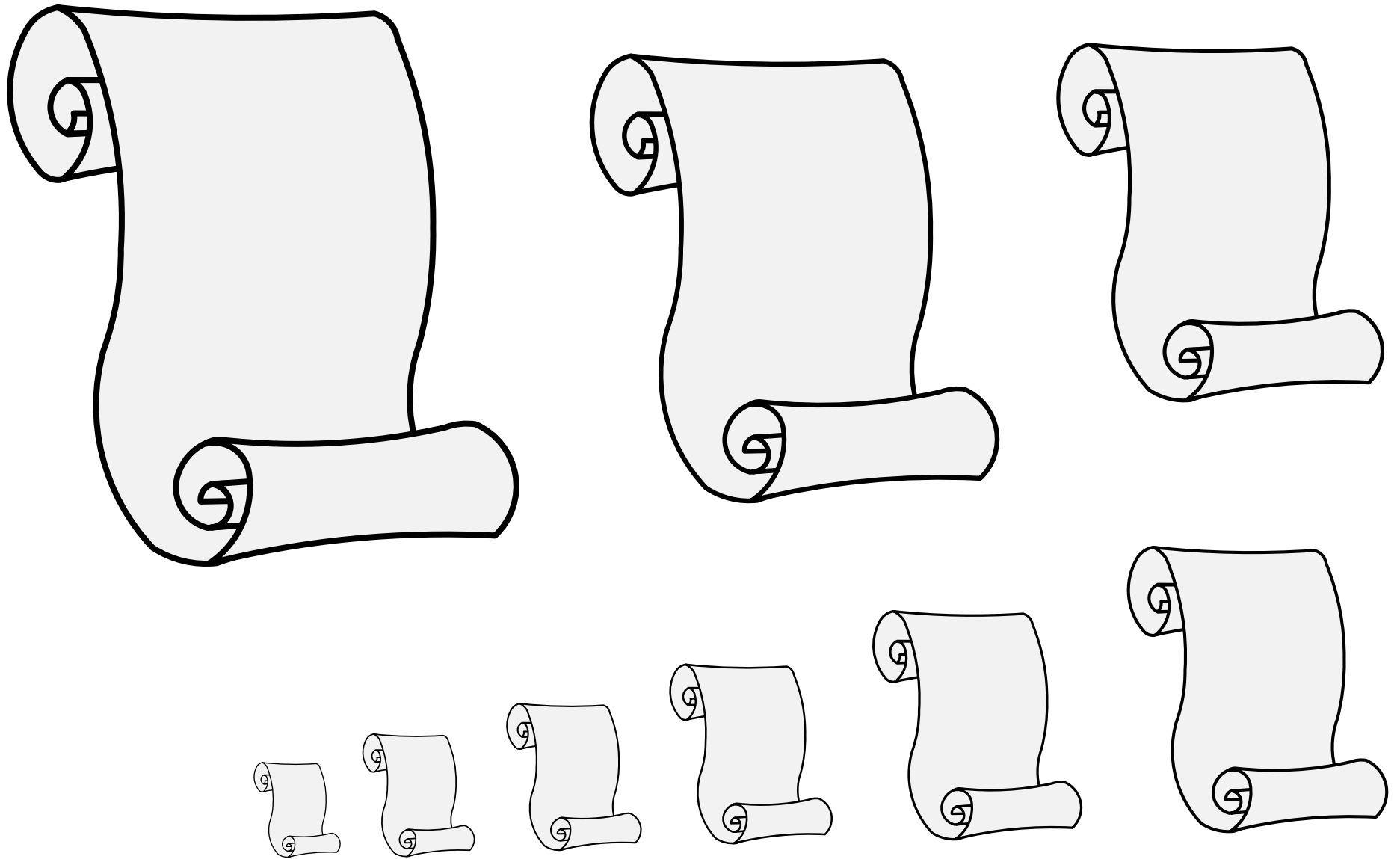

A rolled document, sometimes wrapped around wooden shafts.

An open scroll has a section exposed for reading.

No default orientation.

Source: Viking Answer Lady SVG Images For Heraldry. Artist: Gunnvör silfráhr.

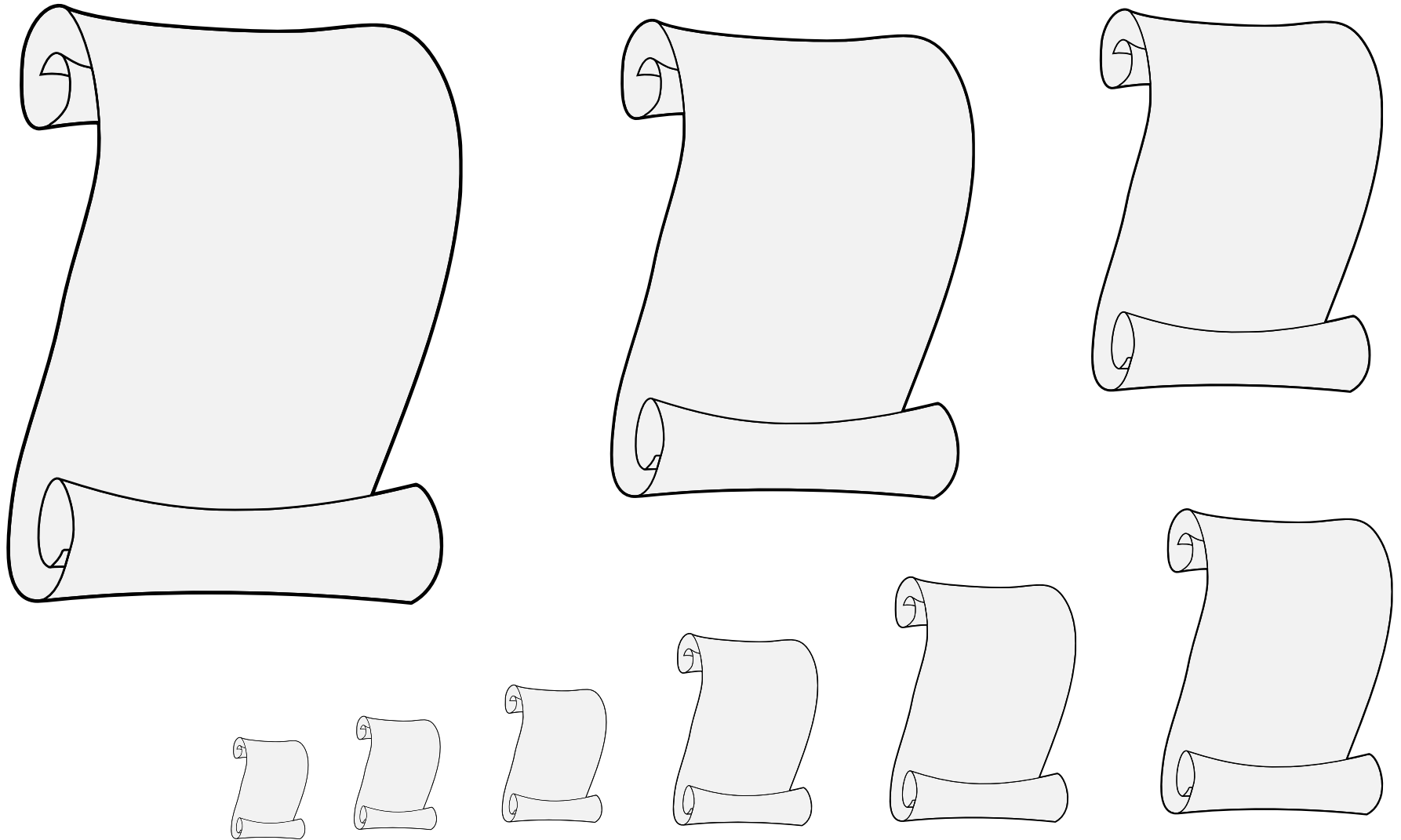

A rolled document, sometimes wrapped around wooden shafts.

An open scroll has a section exposed for reading.

No default orientation. No proper coloration.

Source: SVG Heraldry Components. Artist: Nicholas de Estleche.

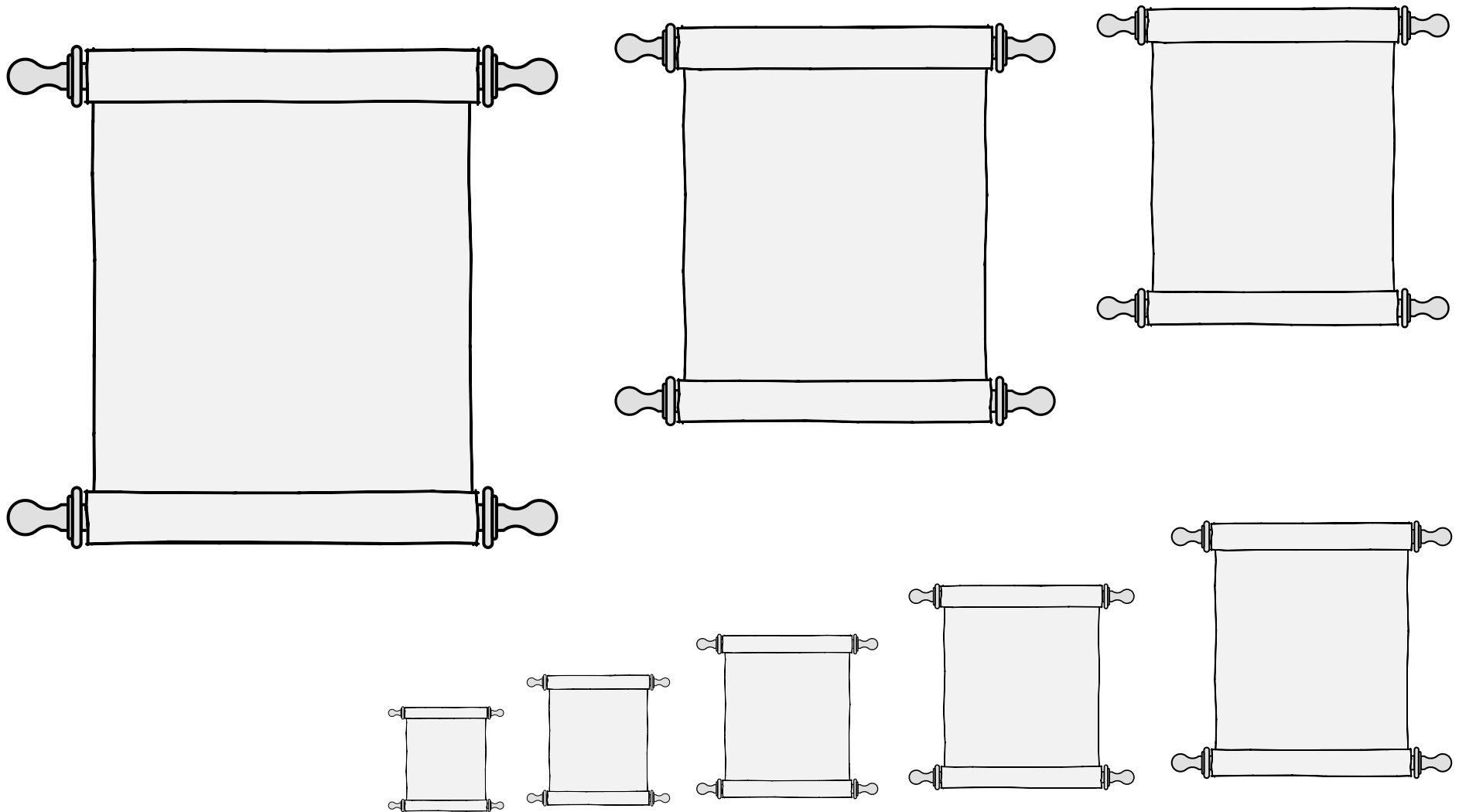

A rolled document, sometimes wrapped around wooden shafts.

An open scroll has a section exposed for reading.

No default orientation. No proper coloration.

Scroll, Open (5) • 18.183

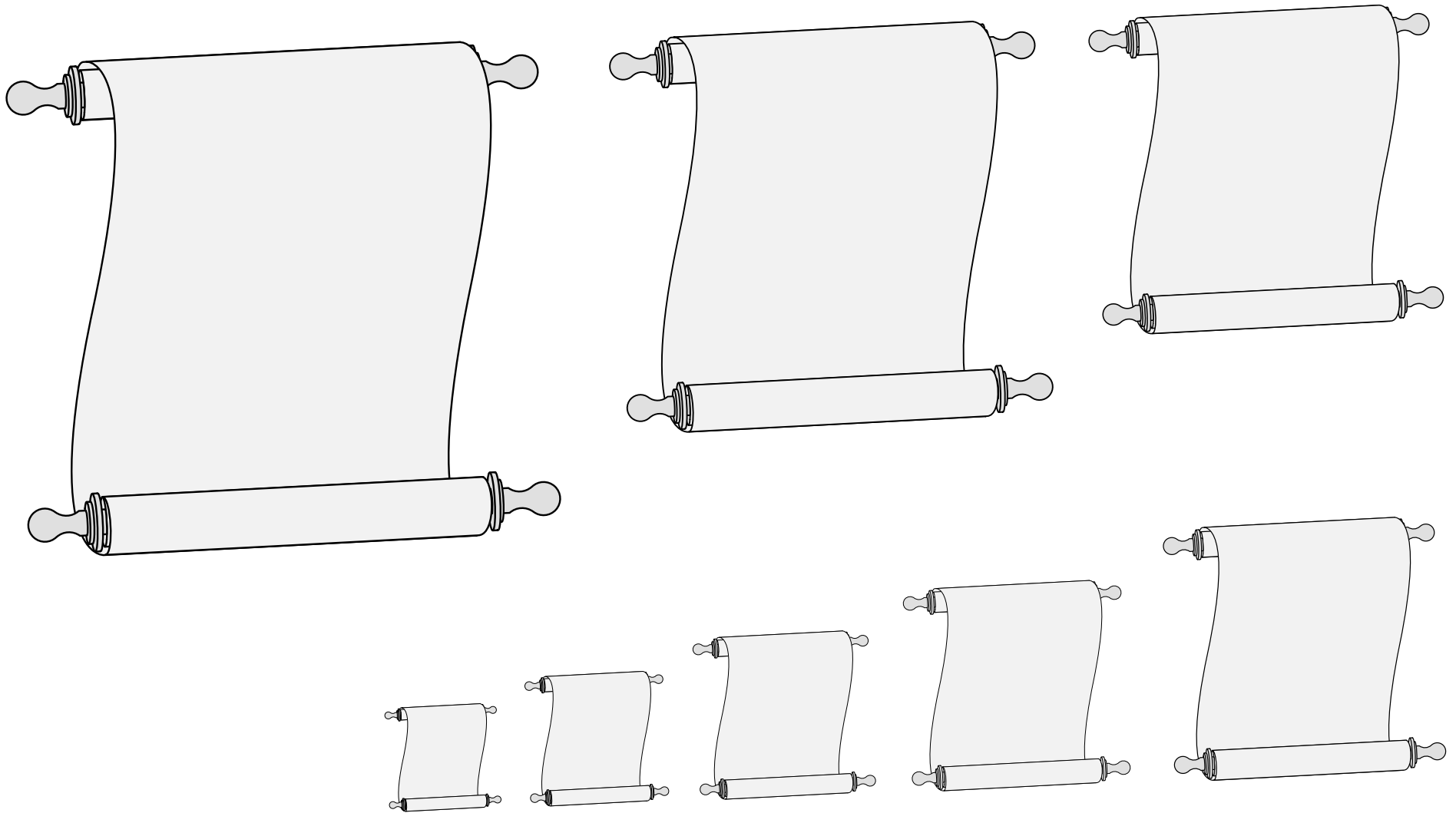

A rolled document, sometimes wrapped around wooden shafts.

An open scroll has a section exposed for reading.

No default orientation. No proper coloration.

Scroll, Open (6) 18.184

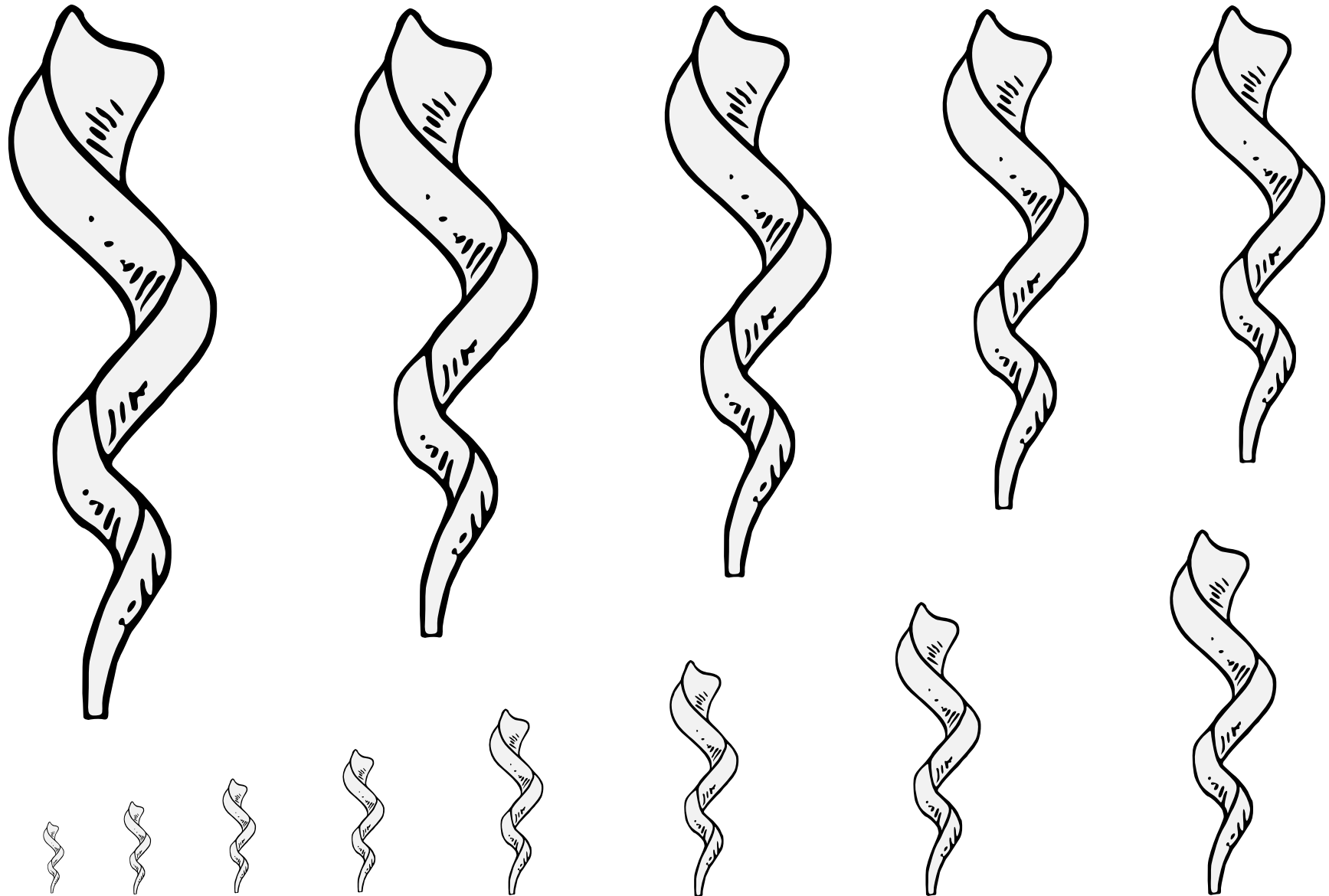

A ram's horn used as a musical instrument, especially in Jewish religious ceremonies.

Default alignment: fesswise, bell to dexter.

Source: Pennsic Traceable Art. Artist: Roana d'Evreux.

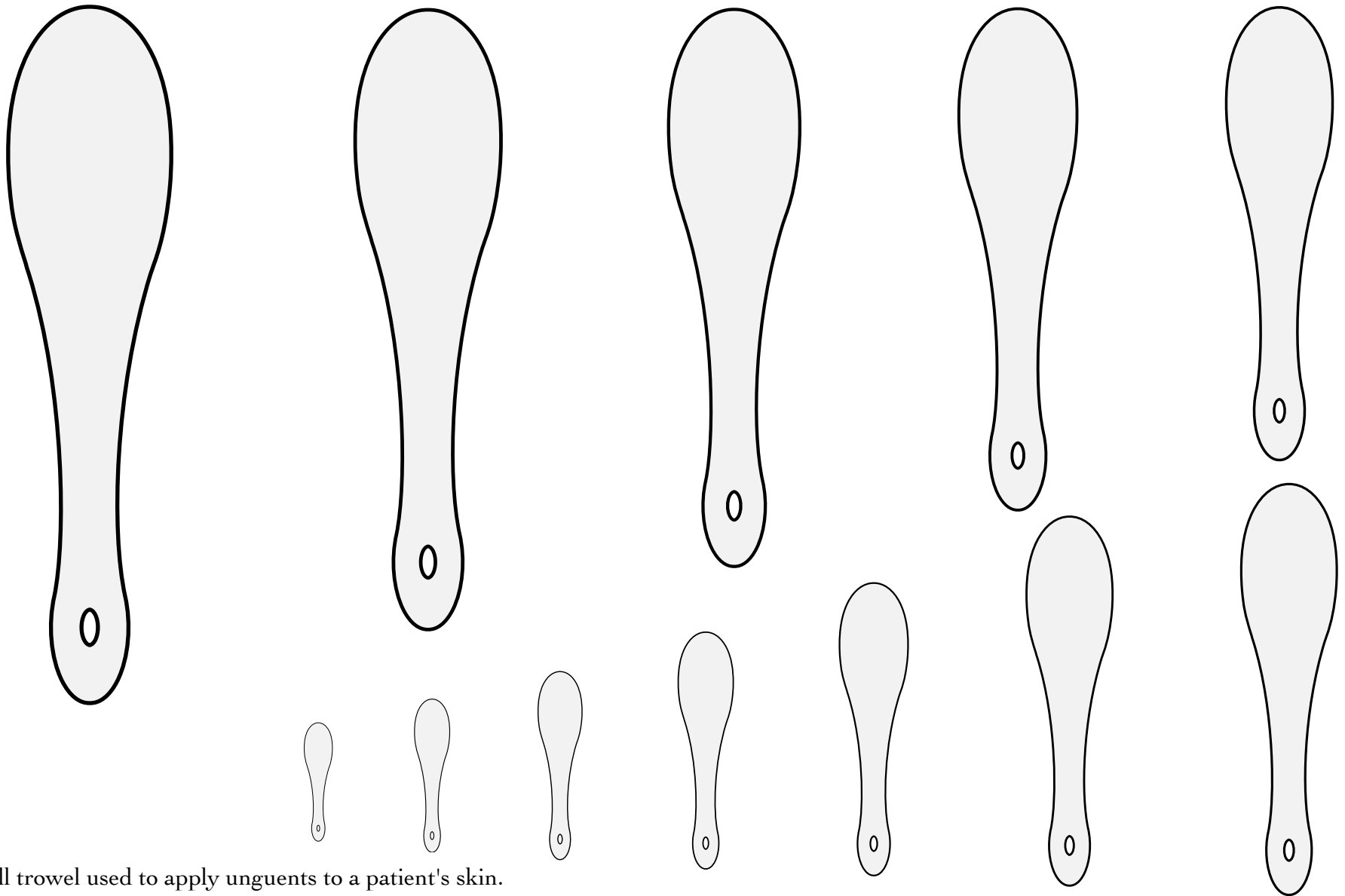

A small trowel used to apply unguents to a patient's skin.

Default orientation: handle to base. No proper coloration.

A spatula appears in the arms of the Company of Barbers and Surgeons, granted 1569.

Source: Les Blasons des Communautés d'Apothecaires au XVIIe Siècle. Artist unknown.

Spatula, Apothecary's 18.186

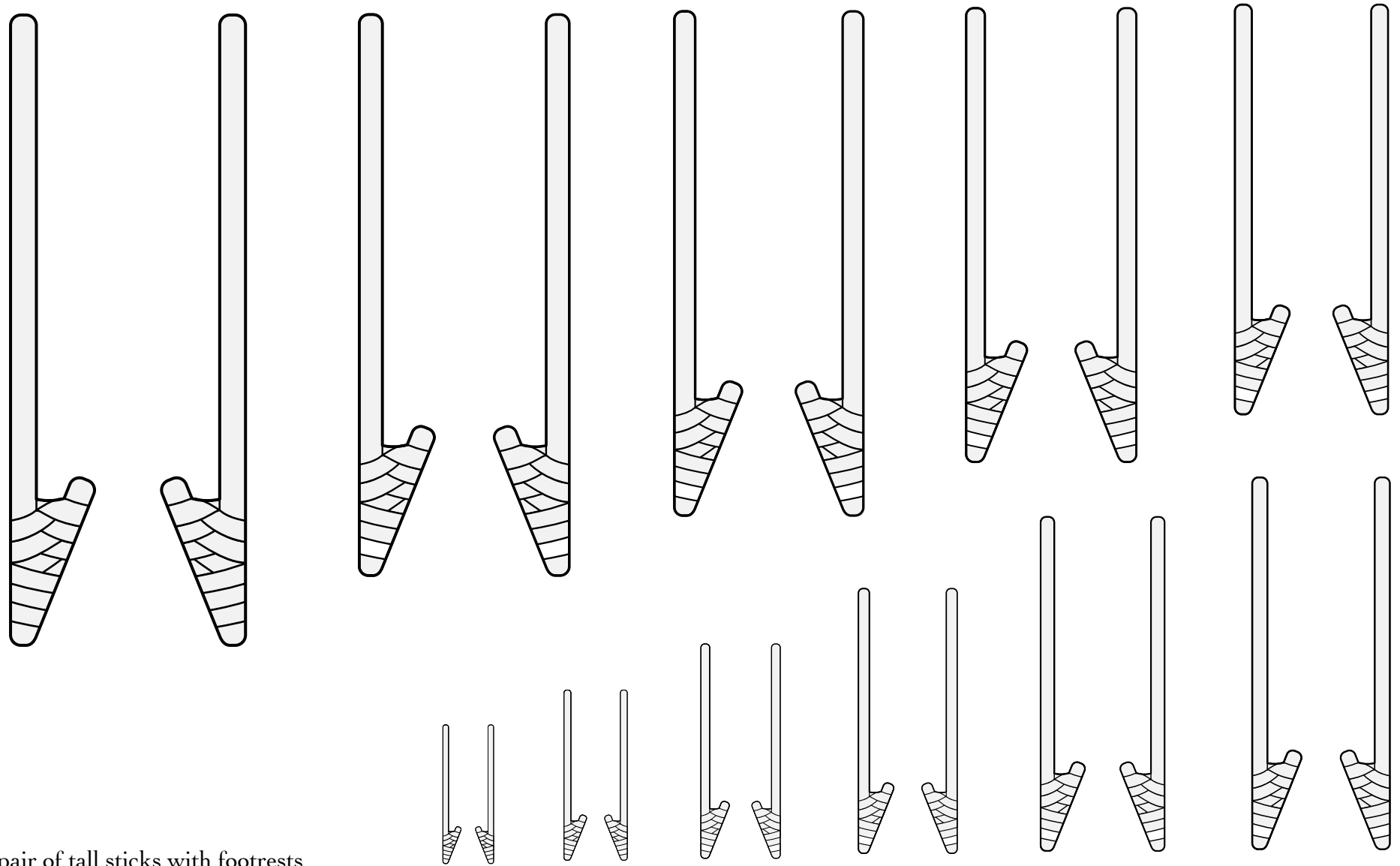

A pair of tall sticks with footrests typically used for entertainment.

Default orientation: upright. No proper coloration.

Source: Stemmario Trivulziano. Artist: Gian Antonio da Tradate. (Page 210, arms of di Scanzoli.)

Stilts, Pair of (1) 18.187

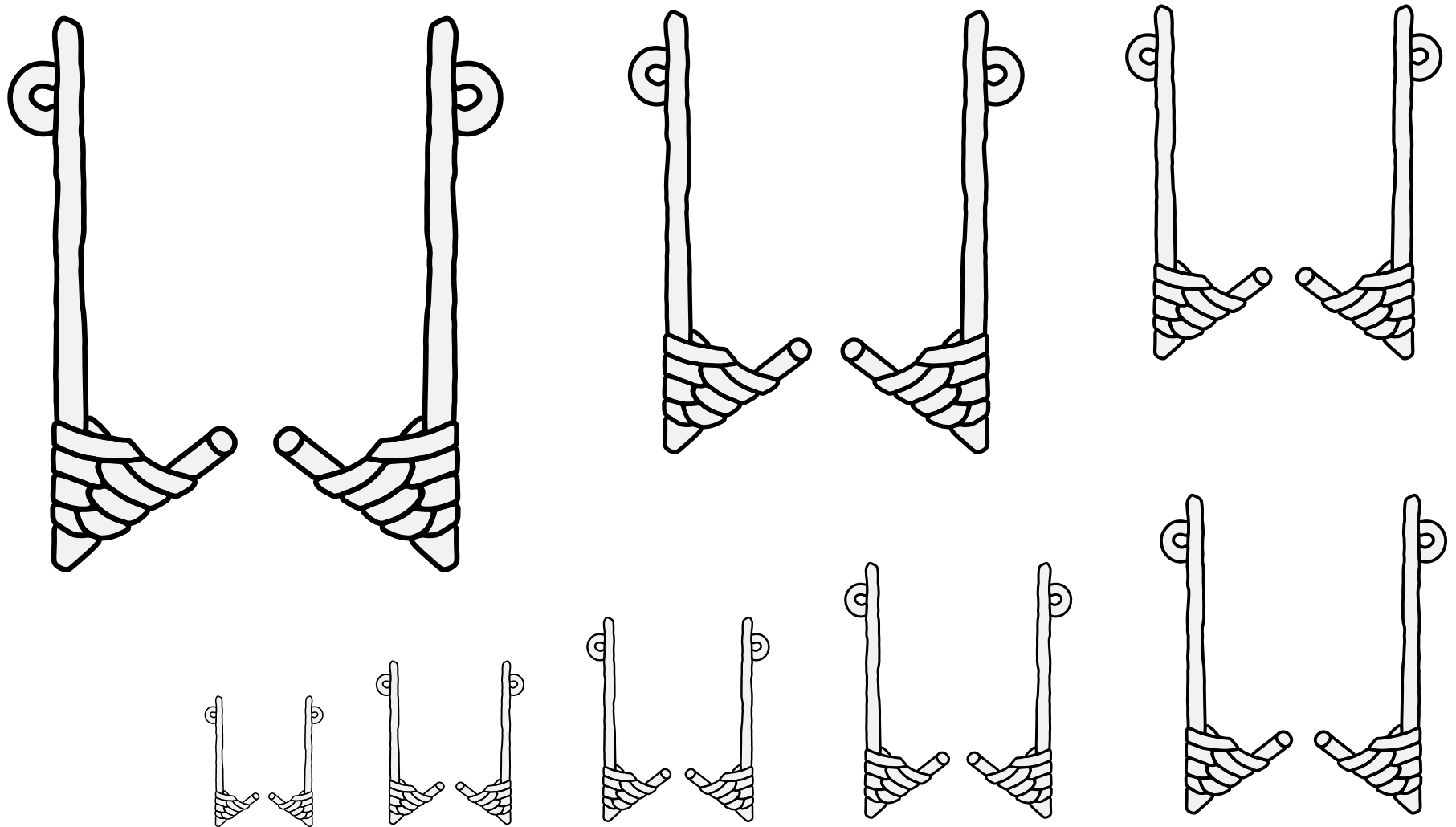

A pair of tall sticks with footrests typically used for entertainment.

Default orientation: upright. No proper coloration.

Source: Wappenbuch der Arlberg-Bruderschaft.
Artist: Vigil Raber. (Page 365.)

Stilts, Pair of (2) 18.188

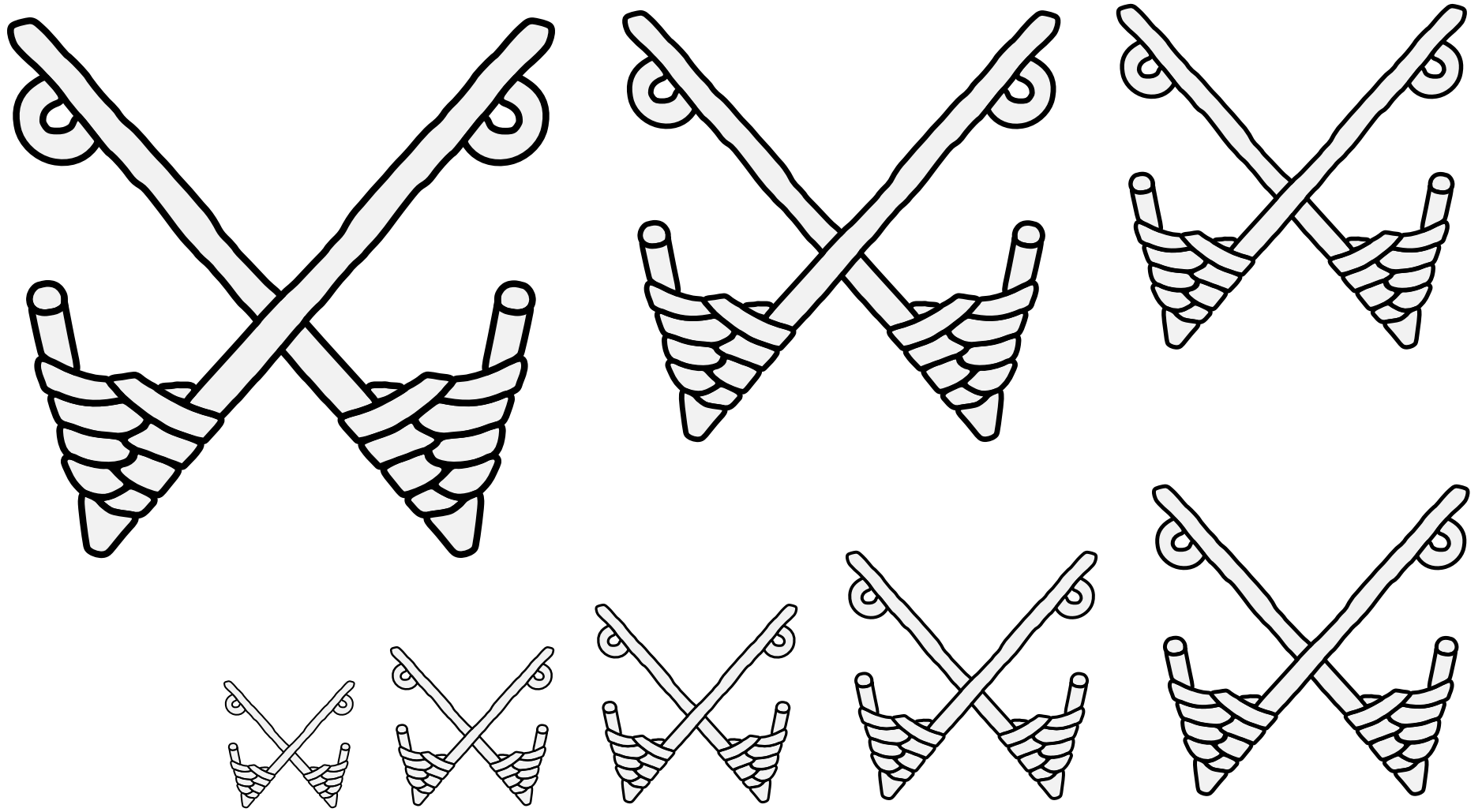

A pair of tall sticks with footrests typically used for entertainment.

Default orientation: upright. No proper coloration.

Source: Wappenbuch der Arlberg-Bruderschaft.

Artist: Vigil Raber. (Page 365.)

Stilts, Pair of, In Saltire 18.189

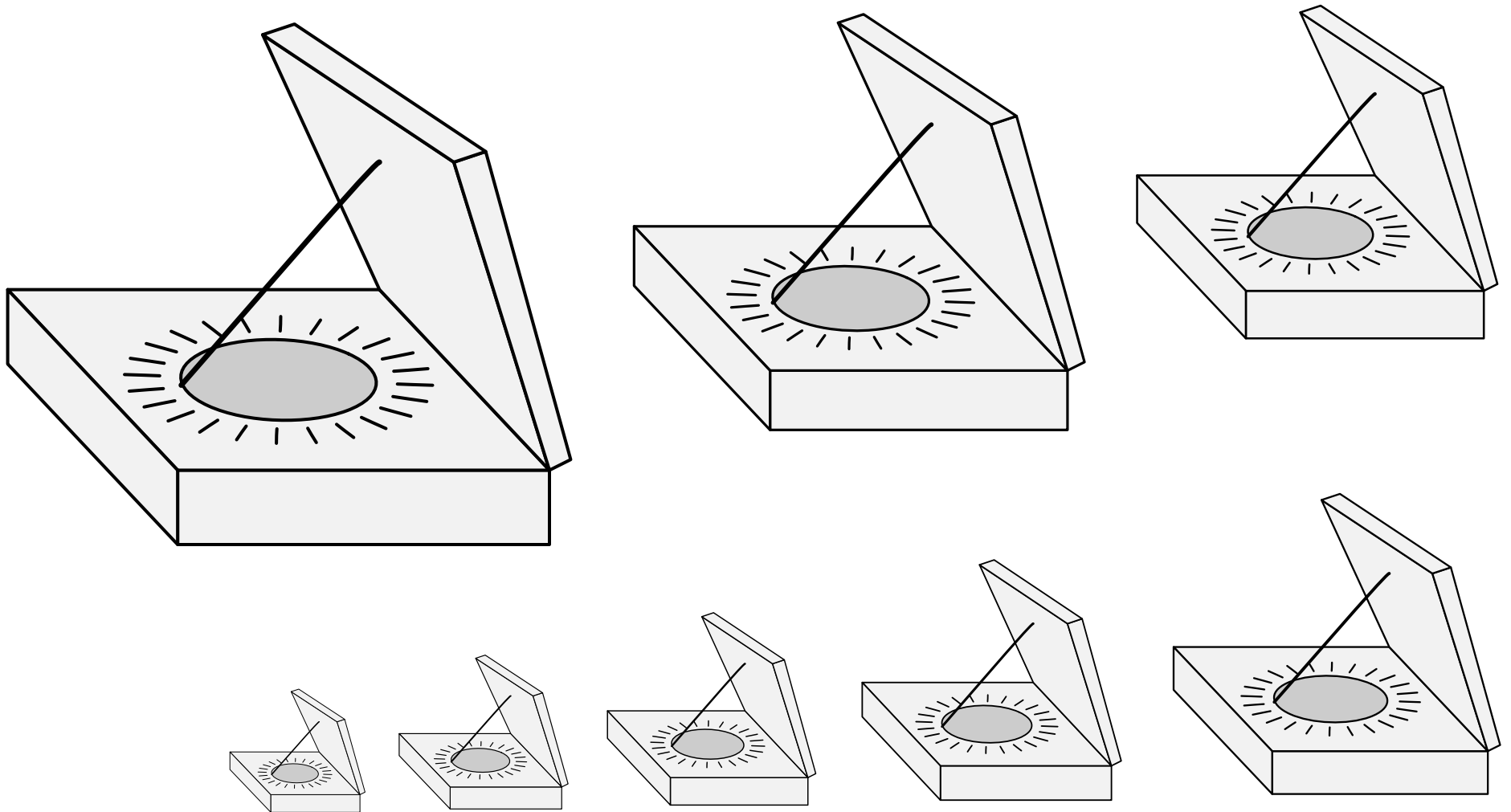

A mechanism of telling time by measuring the angle of the sun's shadow. Several very different varieties of sundial were used in period.

Default orientation: upright. No proper coloration.

Source: Österreichisches Staatsarchiv. (Arms of Ulrich Schniep.)

Artist unknown.

Sundial, Diptych • 18.190

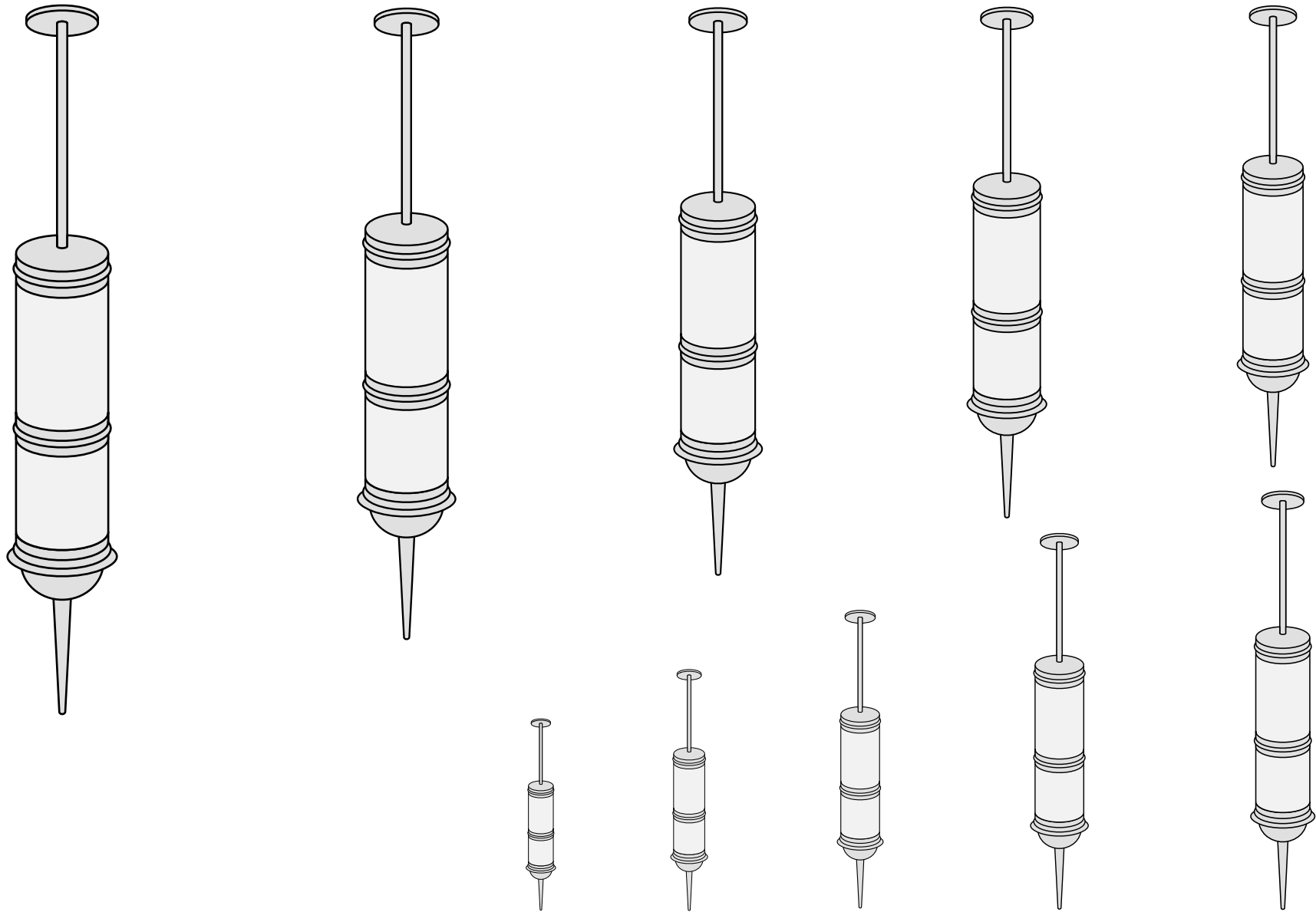

A mechanism for precisely dispensing fluids.
No default orientation. No proper coloration.
Livre de Rebus en Blasons. (BNF Français 5658.)

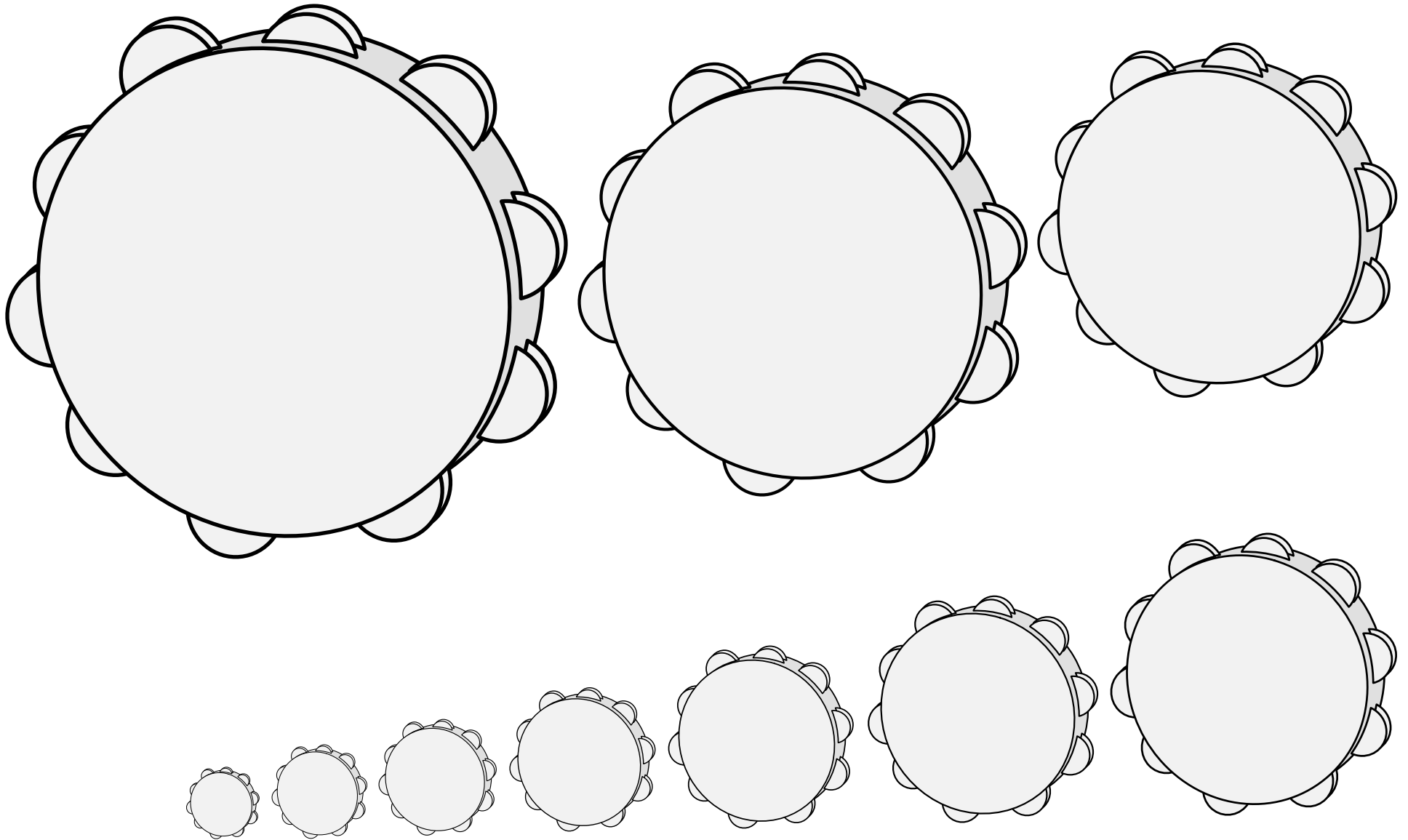

A percussion instrument consisting of a drum with attached zills.
Default orientation: affronty. No proper coloration.

Tambourine 18.192

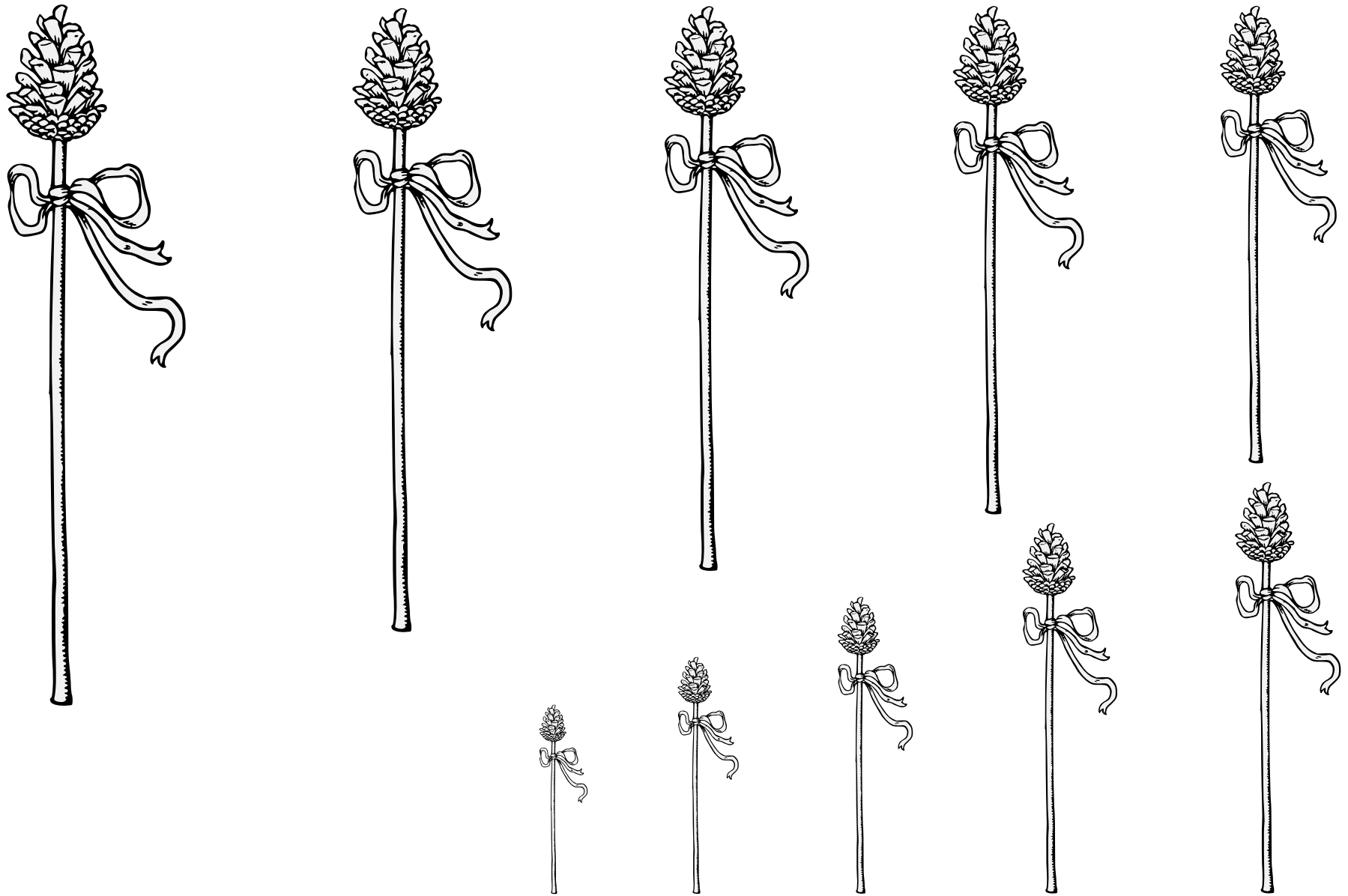

A staff topped with a pinecone or similarly shaped finial, used as a symbol of Dionysus.

Default orientation: head to chief. Proper coloration: brown wood, wreathed vert.

Source: The Principles of Design. Artist: George Woolliscroft-Rhead.



A long tubular wind instrument. May be blazoned a “straight trumpet.”
Default orientation: bell to chief. No proper coloration.

Trumpet (1) 18.194

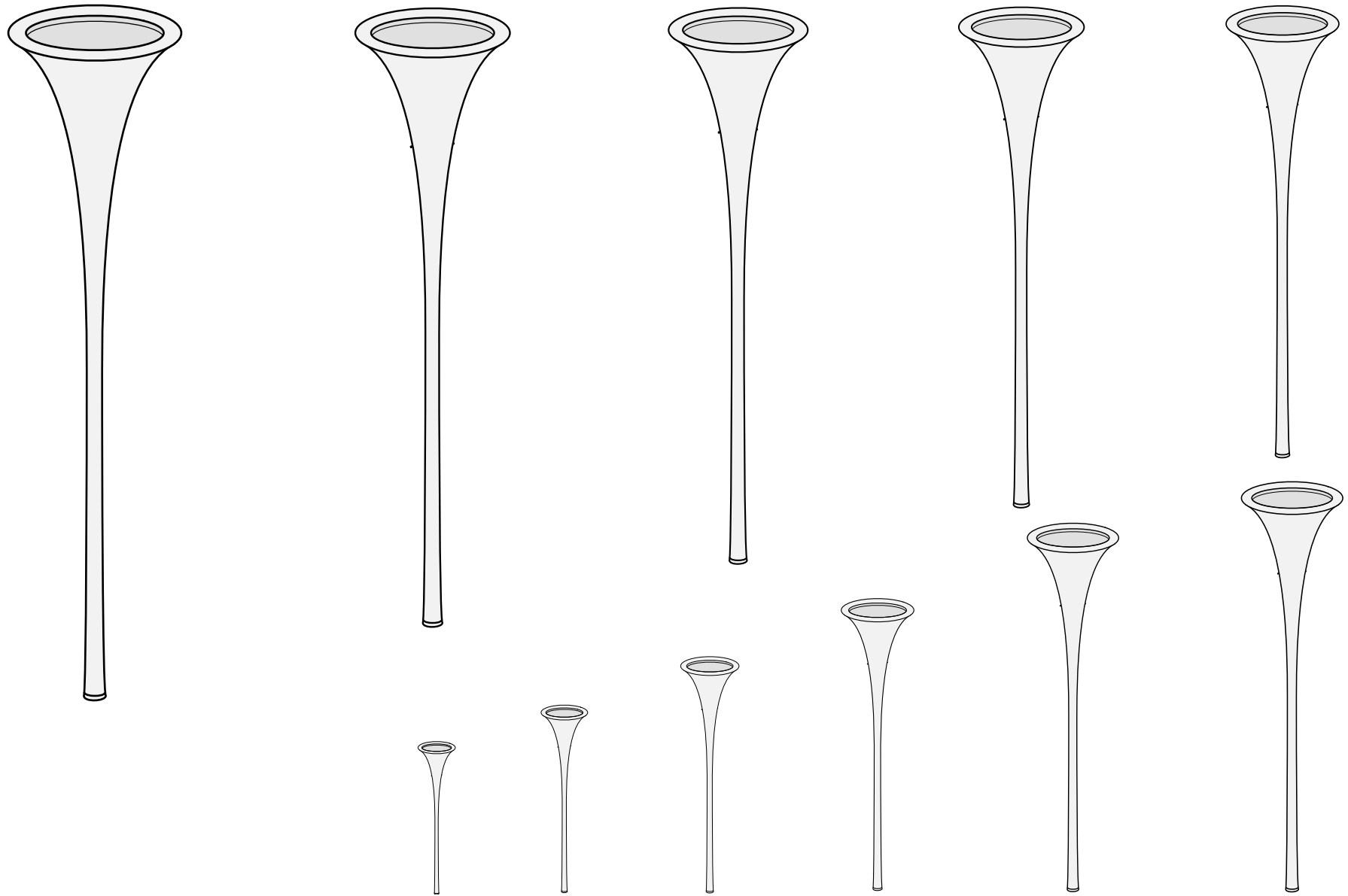

A long tubular wind instrument. May be blazoned a “straight trumpet.”

Default orientation: bell to chief. No proper coloration.

Source: Chronicle of the Council of Constance. Artist unknown. (Folio 39r.)

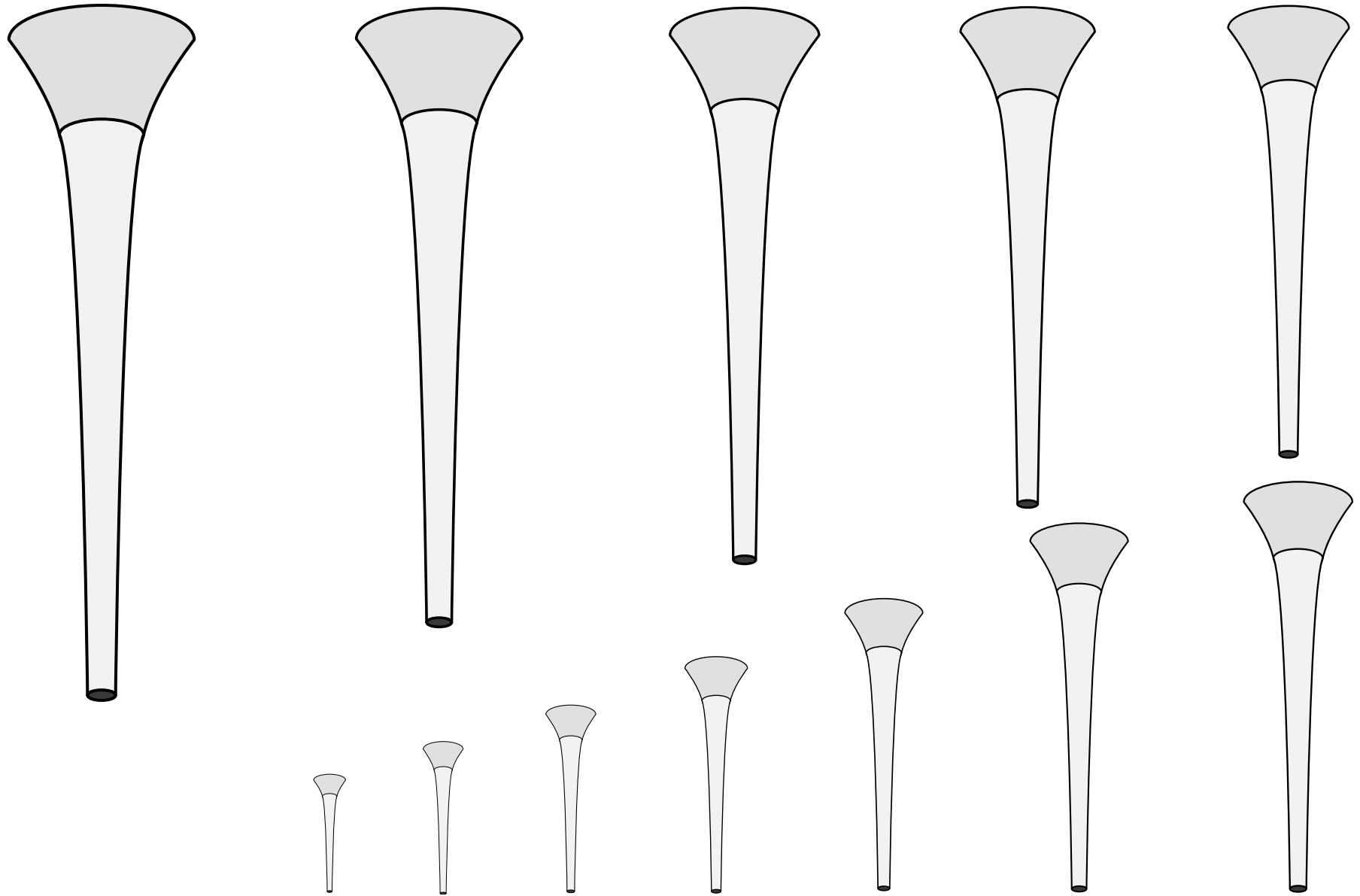

A long tubular wind instrument. May be blazoned a “straight trumpet.”

Default orientation: bell to chief. No proper coloration.

Source: Neustifter Wappenbuch. Artist: Vigil Raber. (Page 12.)

Trumpet (3) 18.196

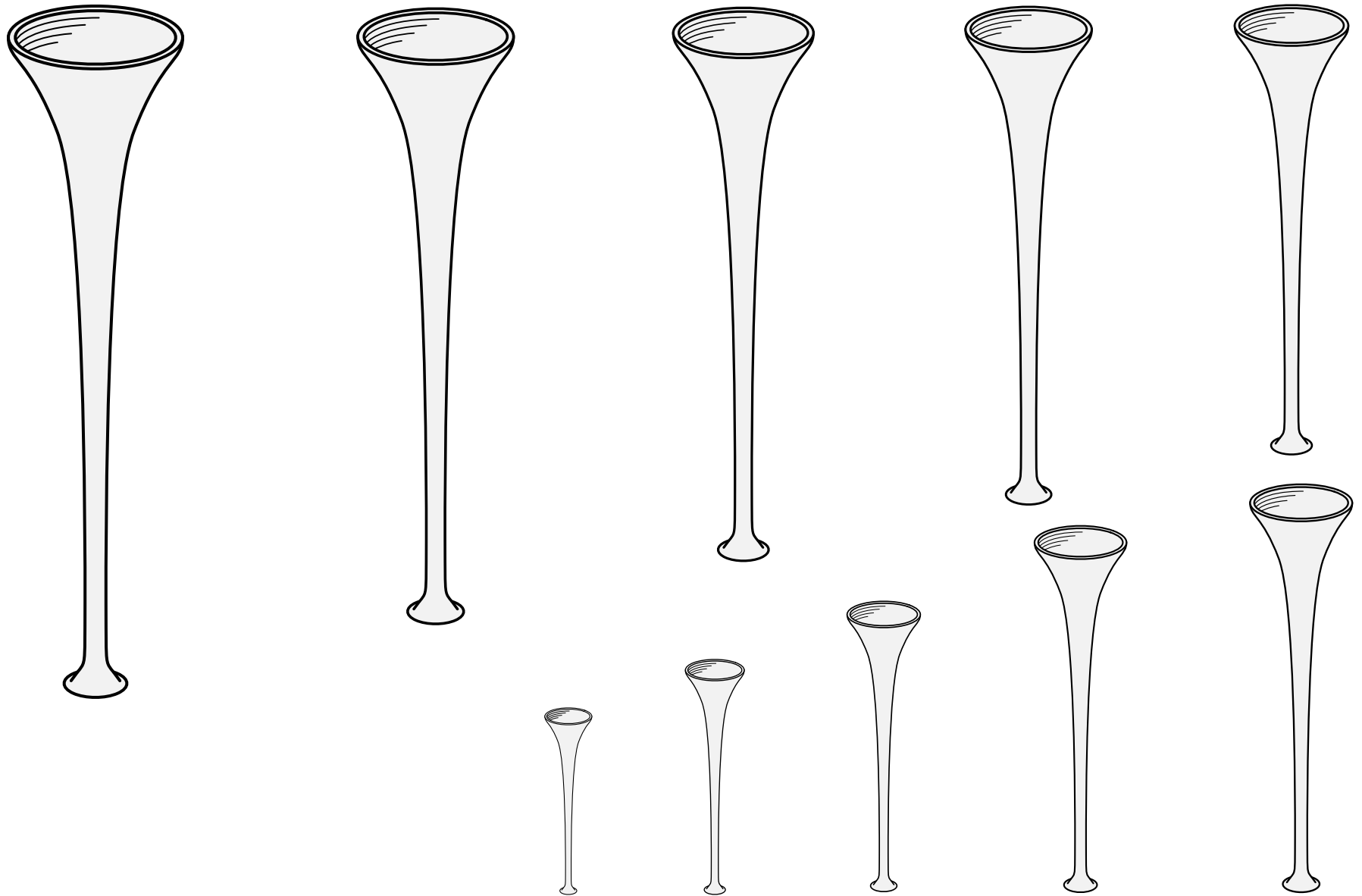

A long tubular wind instrument. May be blazoned a “straight trumpet.”
Default orientation: bell to chief. No proper coloration.

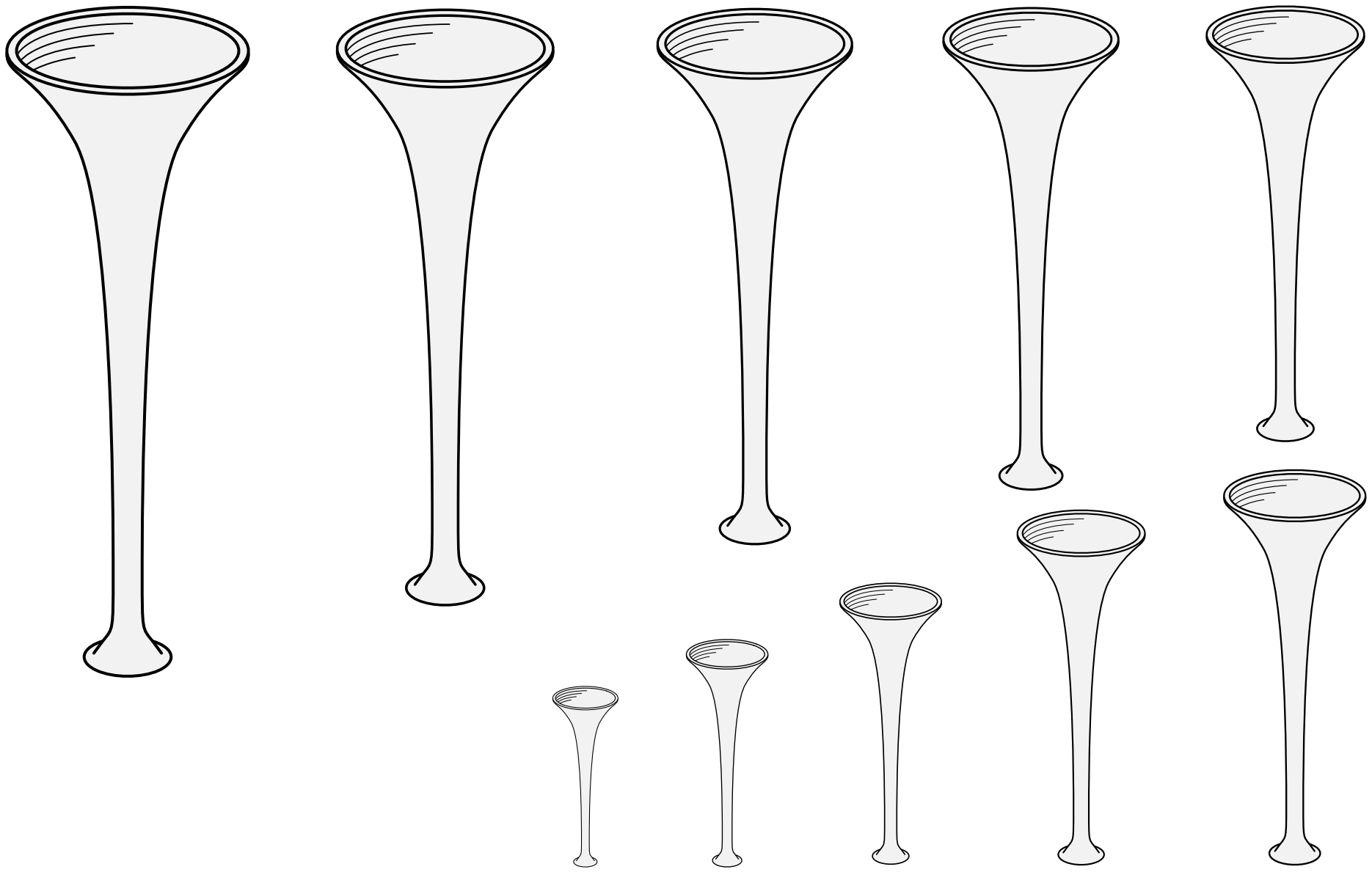

A long tubular wind instrument. May be blazoned a “straight trumpet.”
Default orientation: bell to chief. No proper coloration.

Trumpet (5) 18.198

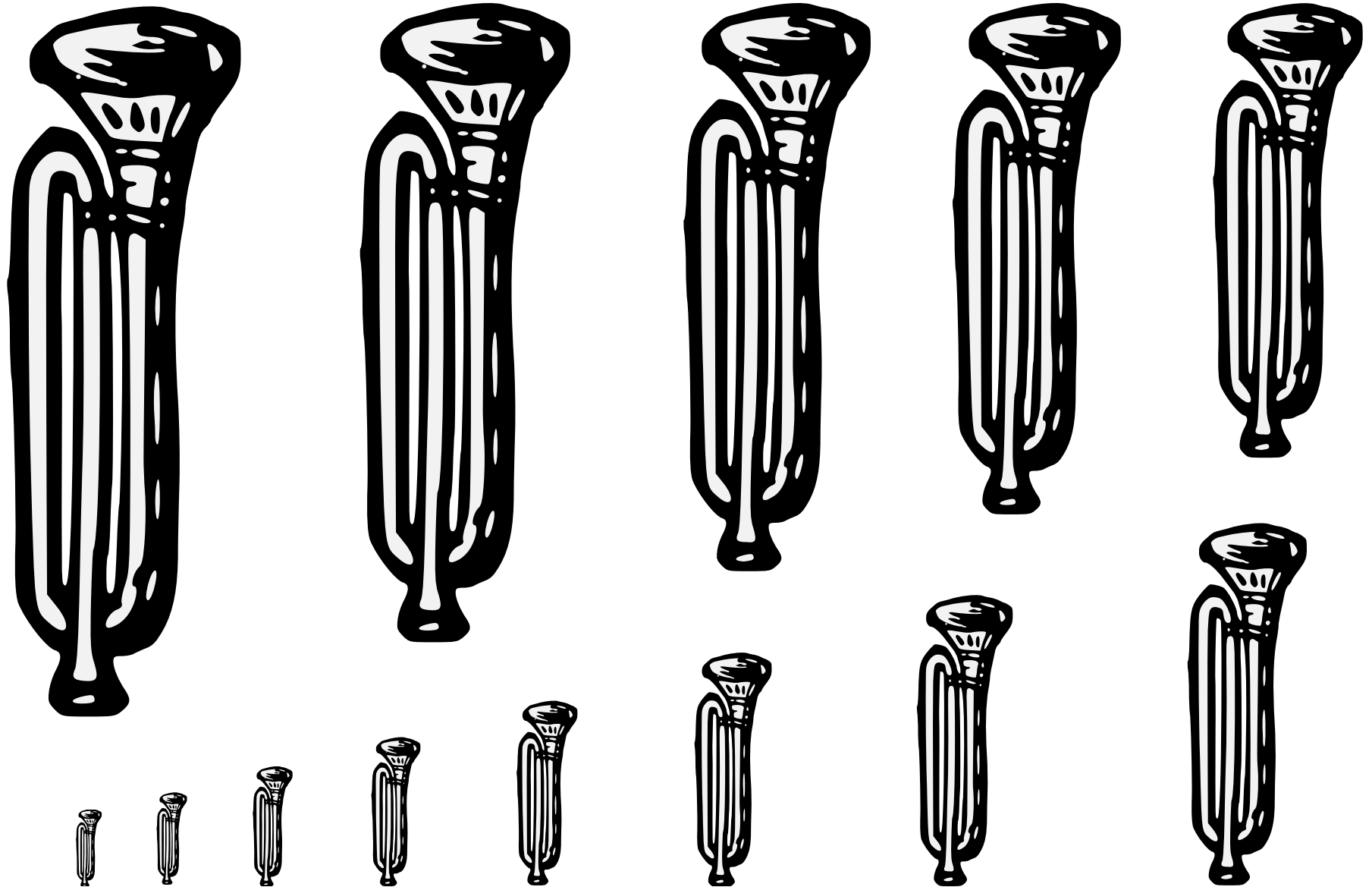

A tubular wind instrument bent into a compact shape.
Default orientation: bell to chief. No proper coloration.
Source: Guillim's Display of Heraldry. Artist unknown.

Trumpet, Baroque Folded (1) 18.199

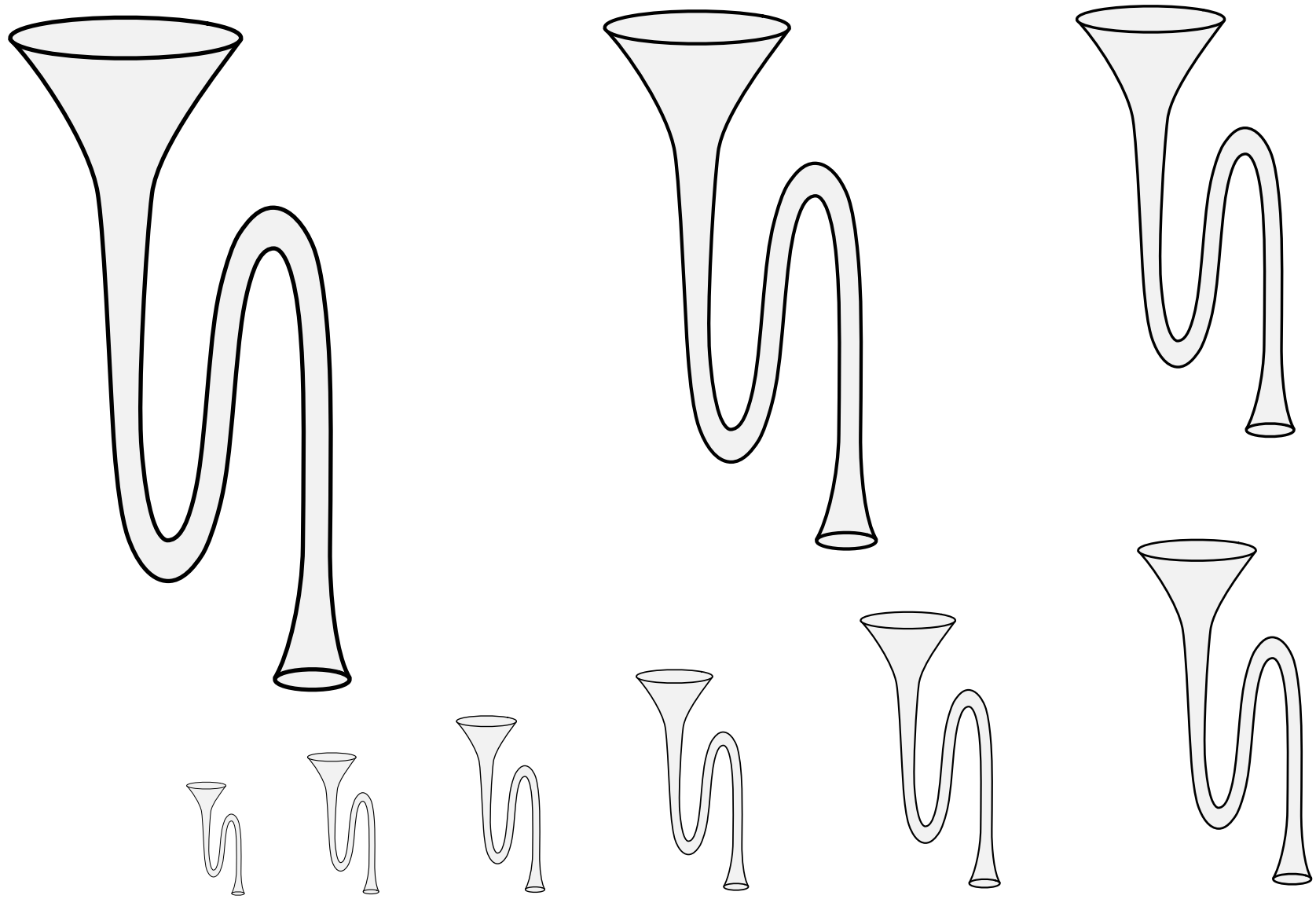

A tubular wind instrument bent into a compact shape.

Default orientation: bell to chief. No proper coloration.

Source: Nobiliario de Armas de Valencia, Aragón y Cataluña. Artist unknown. (Folio 2r.)

Trumpet, Baroque Folded (2) 18.200

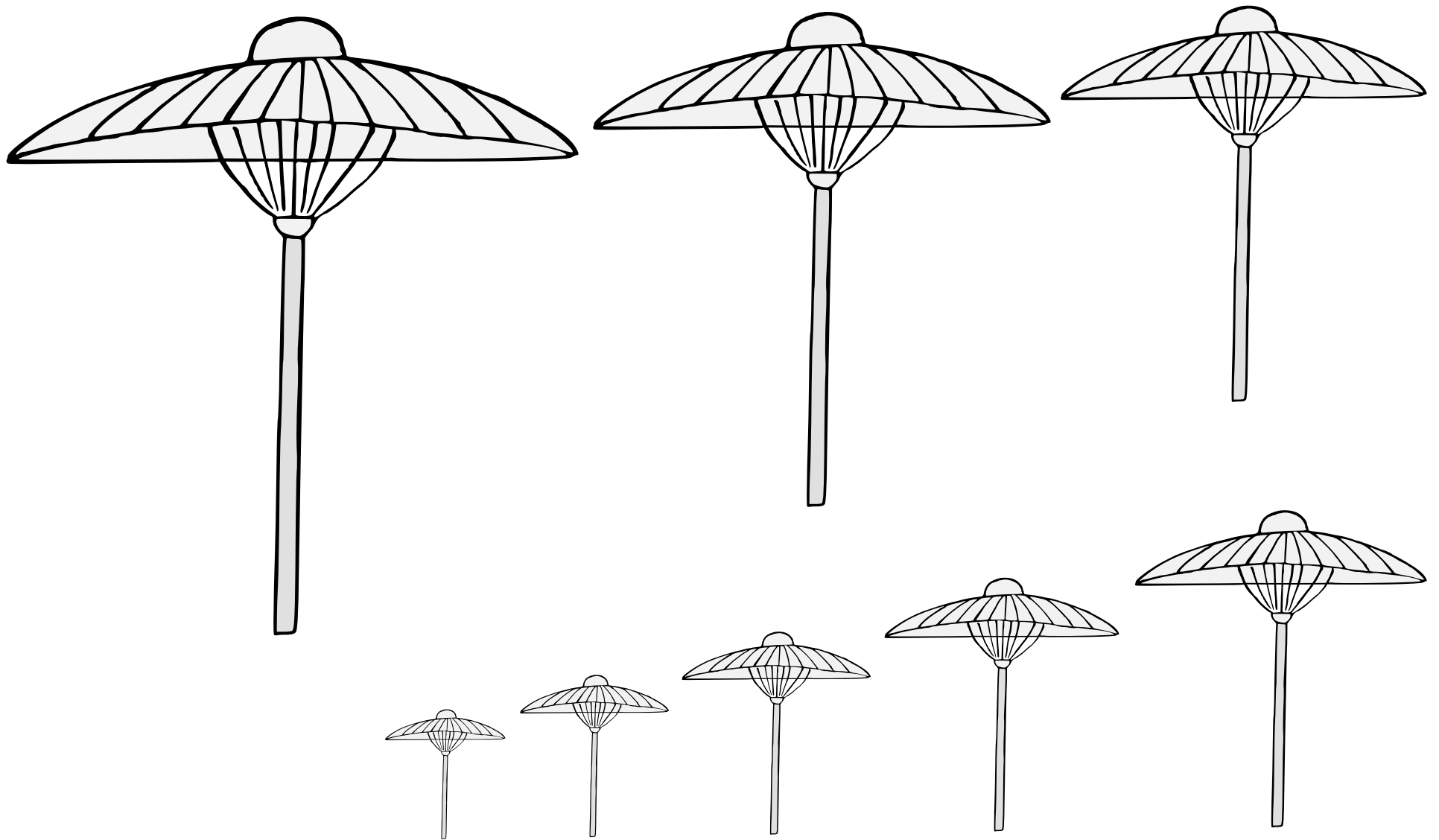

A shade to protect against the sun or rain.
Default orientation: handle to base. No proper coloration.
Source: Kenmon Shokamon. Artist unknown. (Page 41.)

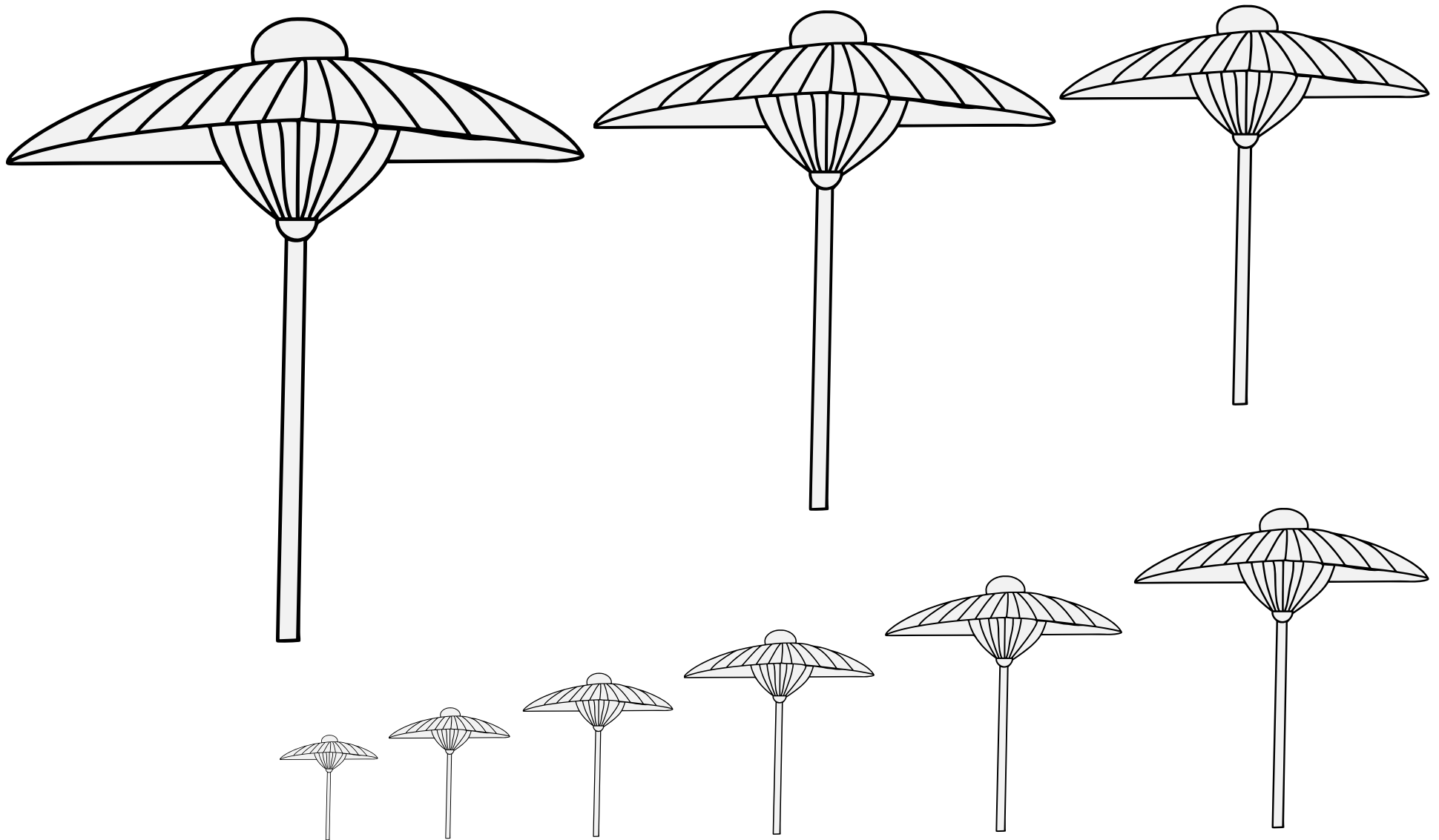

A shade to protect against the sun or rain.

Default orientation: handle to base. No proper coloration.

Source: Kenmon Shokamon. Artist unknown. (Page 41.)

Adapted by Jessimond of Emerickeskepe.

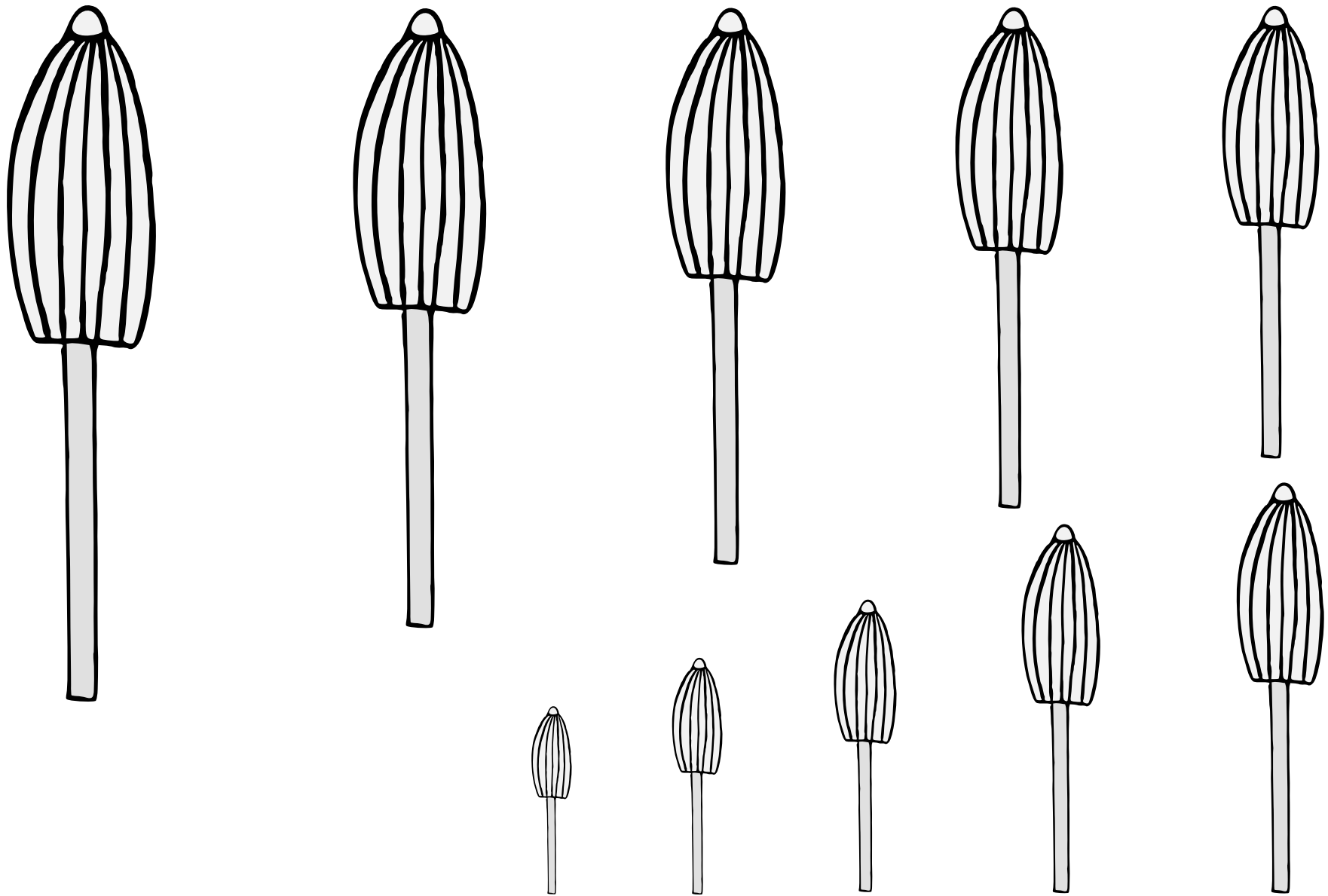

A shade to protect against the sun or rain.

Default orientation: handle to base. No proper coloration.

Source: Kenmon Shokamon. Artist unknown. (Page 41.)

Umbrella, Closed (1) 18.203

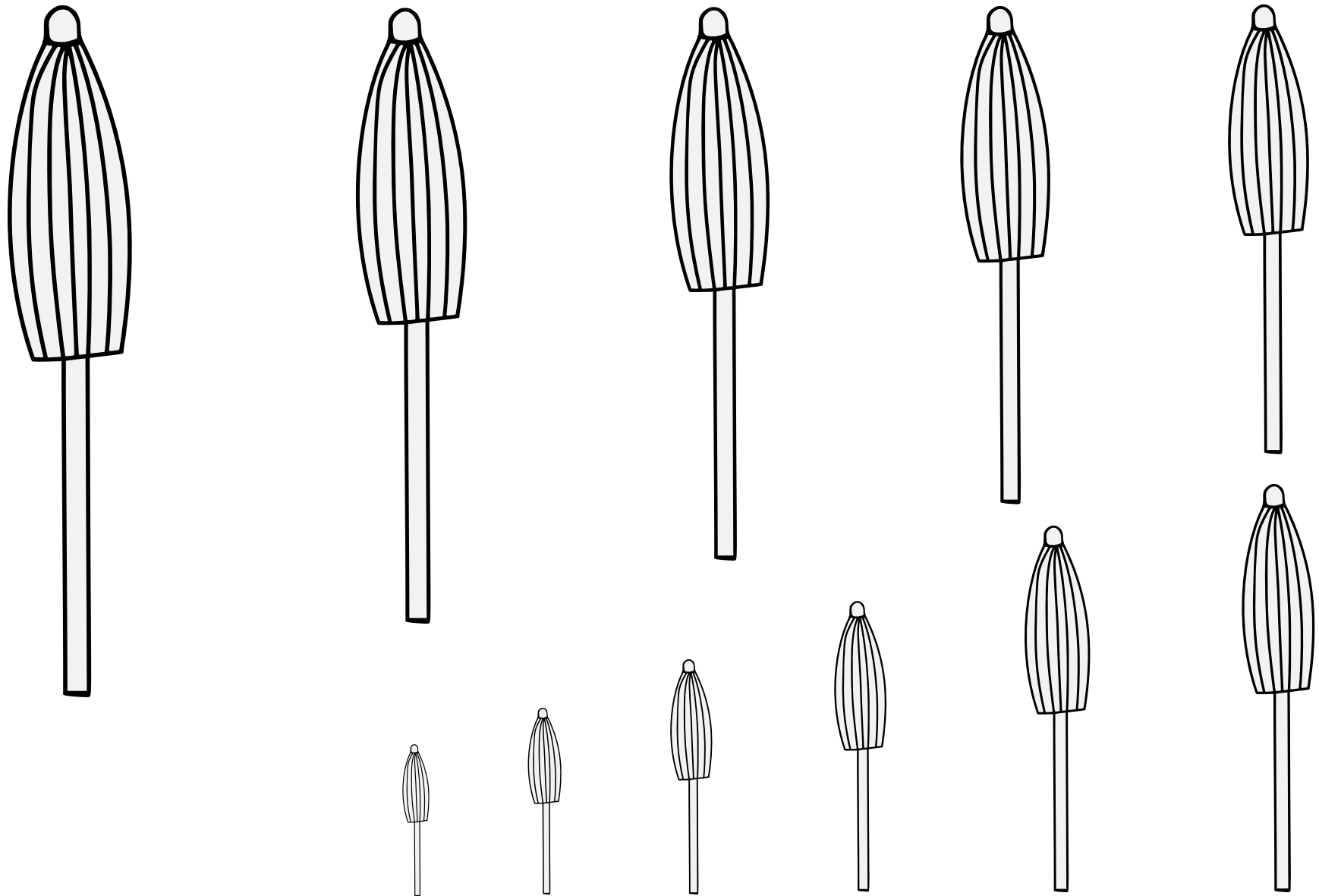

A shade to protect against the sun or rain.

Default orientation: handle to base. No proper coloration.

Source: Kenmon Shokamon. Artist unknown. (Page 41.)

Adapted by Jessimond of Emerickeskepe.

Umbrella, Closed (2) 18.204

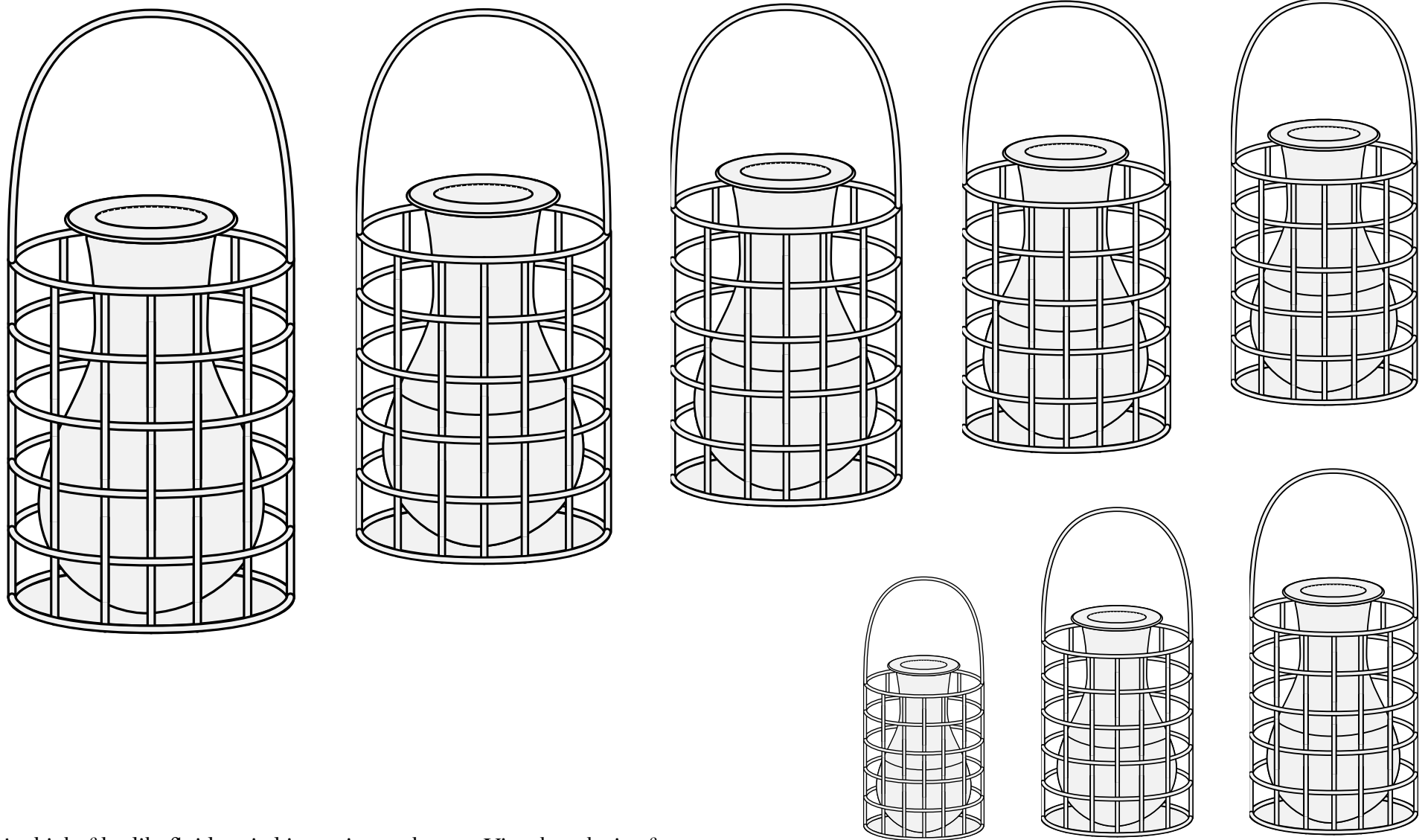

A phial of bodily fluid carried in a wire enclosure. Visual analysis of a patient's urine was an important diagnostic tool in medieval medicine.

Default orientation: upright. No proper coloration.

Source: Heraldry For the Local Historian and Genealogist. Artist unknown. (Arms of Dr Louys Caerlyon, 1483.)

Urinal In A Basket 18.205

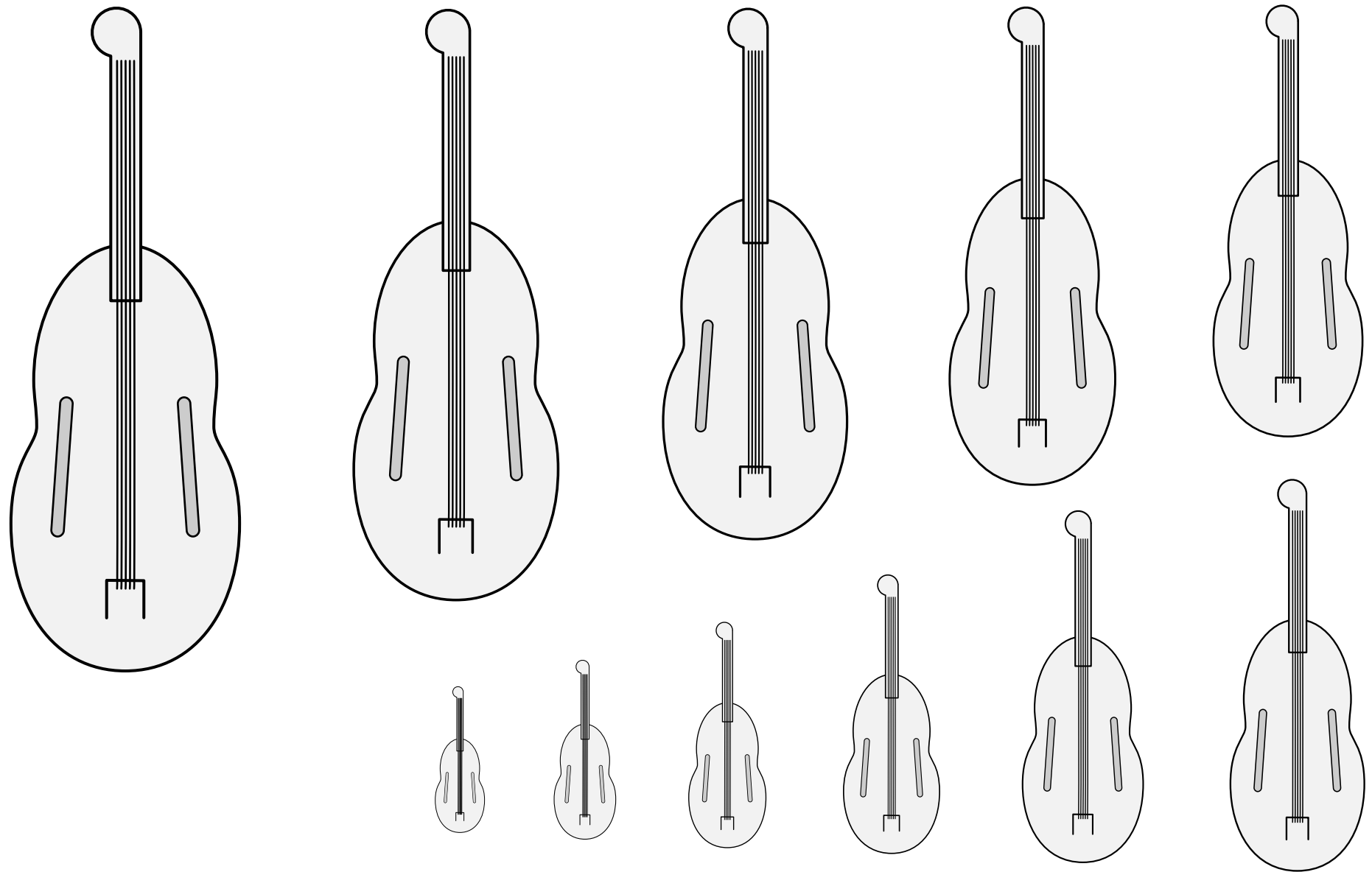

A stringed instrument similar to a violin.

Default orientation: palewise, frets to chief. Proper coloration: brown wood.

Source: The History of Music. Artist unknown.
(Page 258, adapted from a French psalter circa 1400.)

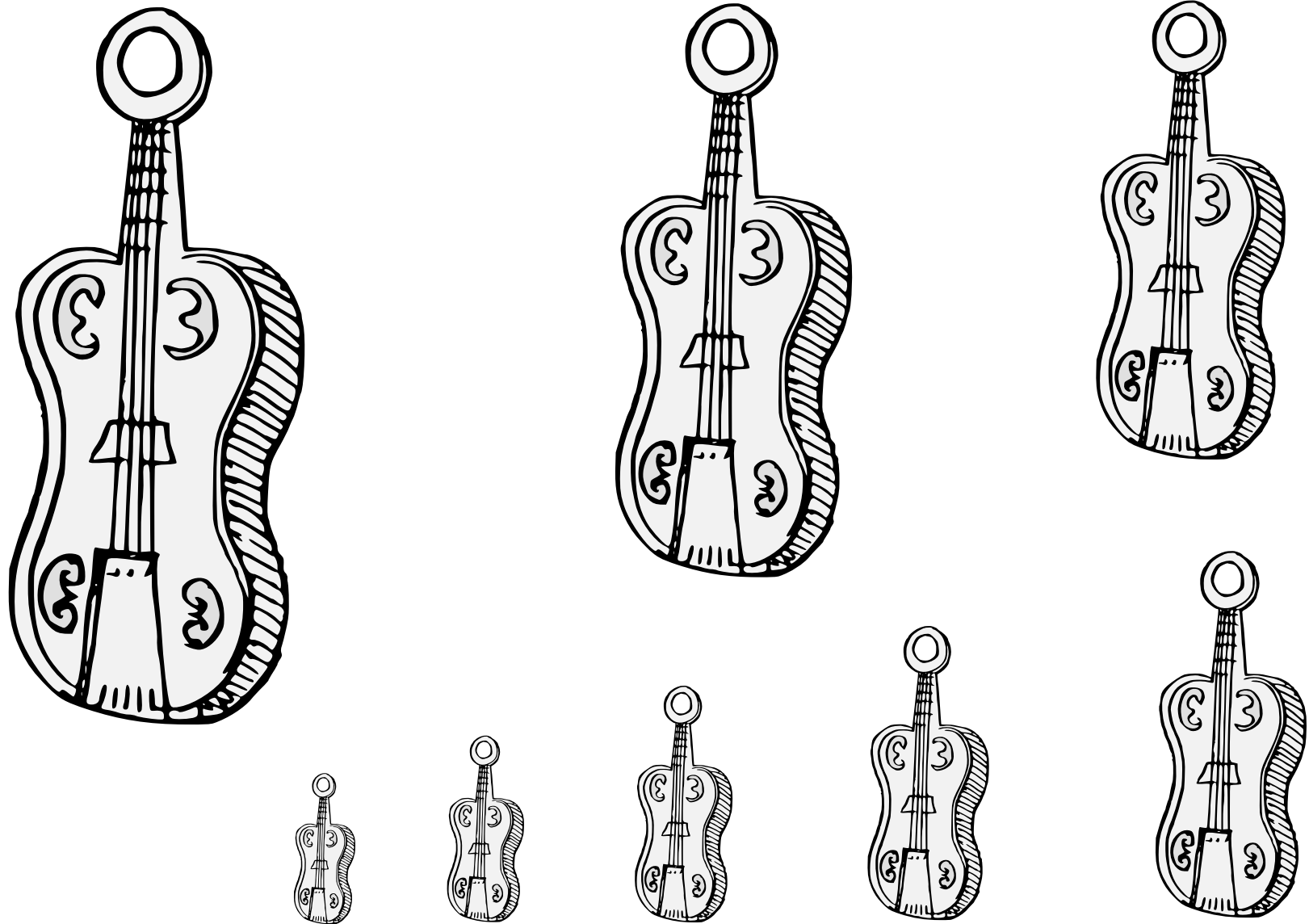

A string instrument.

Default orientation: palewise, frets to chief. No proper coloration.

Source: Aegidius Tschudi's Armorial. Artist unknown.

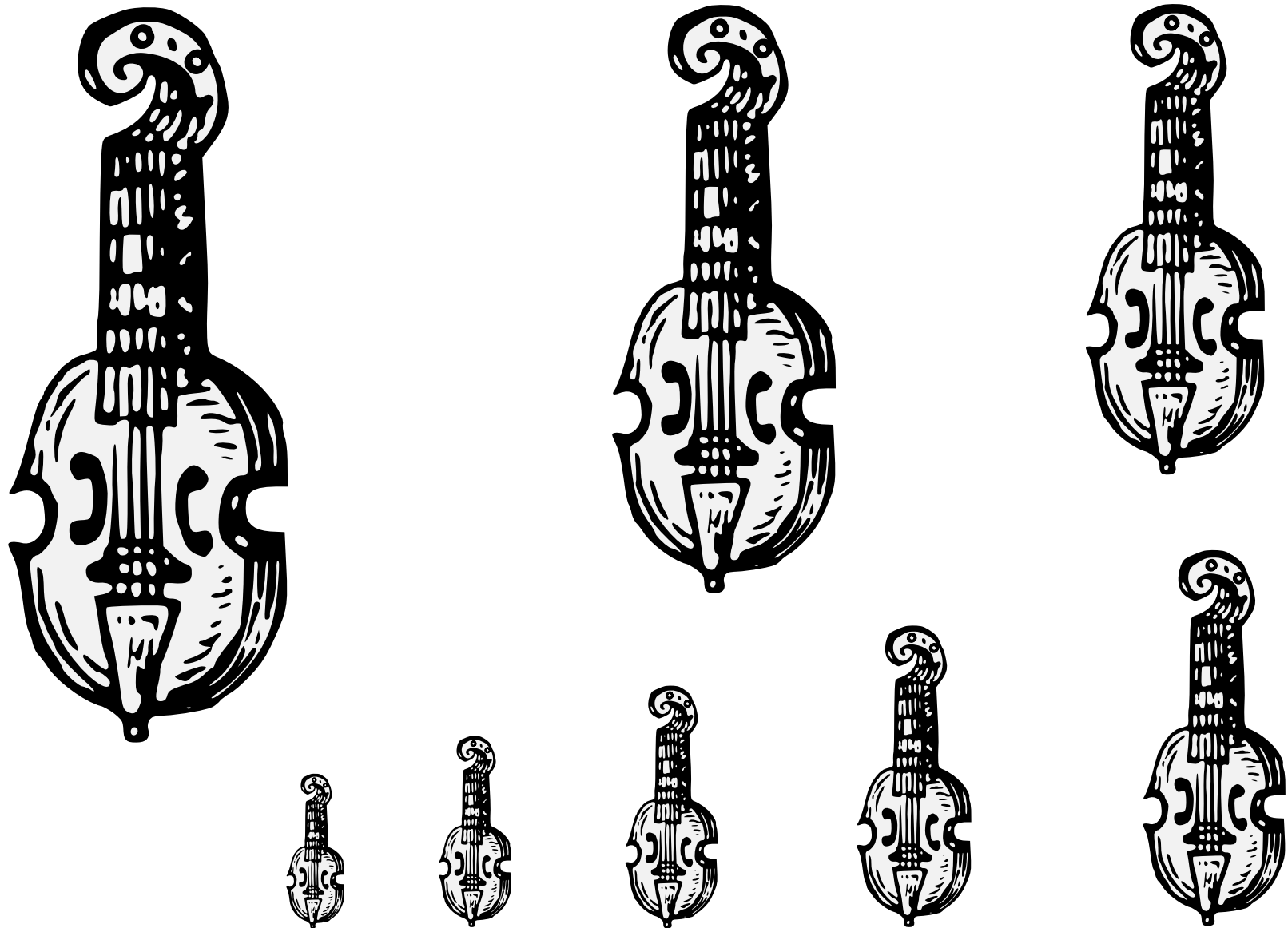

A string instrument.

Default orientation: palewise, frets to chief. No proper coloration.

Source: Guillim's Display of Heraldry. Artist unknown.

Violin 18.208

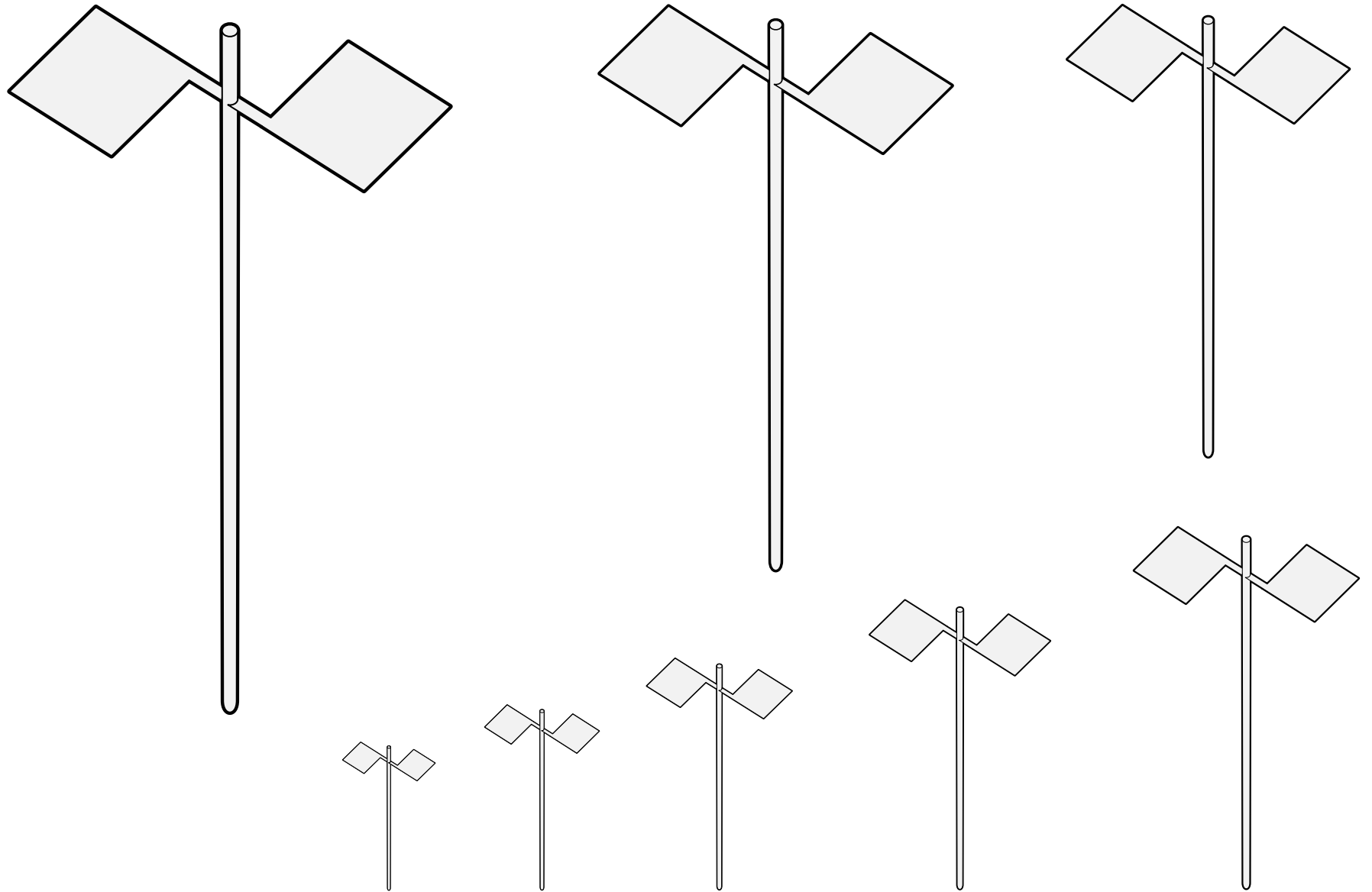

A spinning toy with a central shaft and lateral blades that catch the air.

Default orientation: upright. No proper coloration.

Source: Hamilton Field Hours. Artist unknown. (Folio 19r.)

Whirlingig (1) 18.209

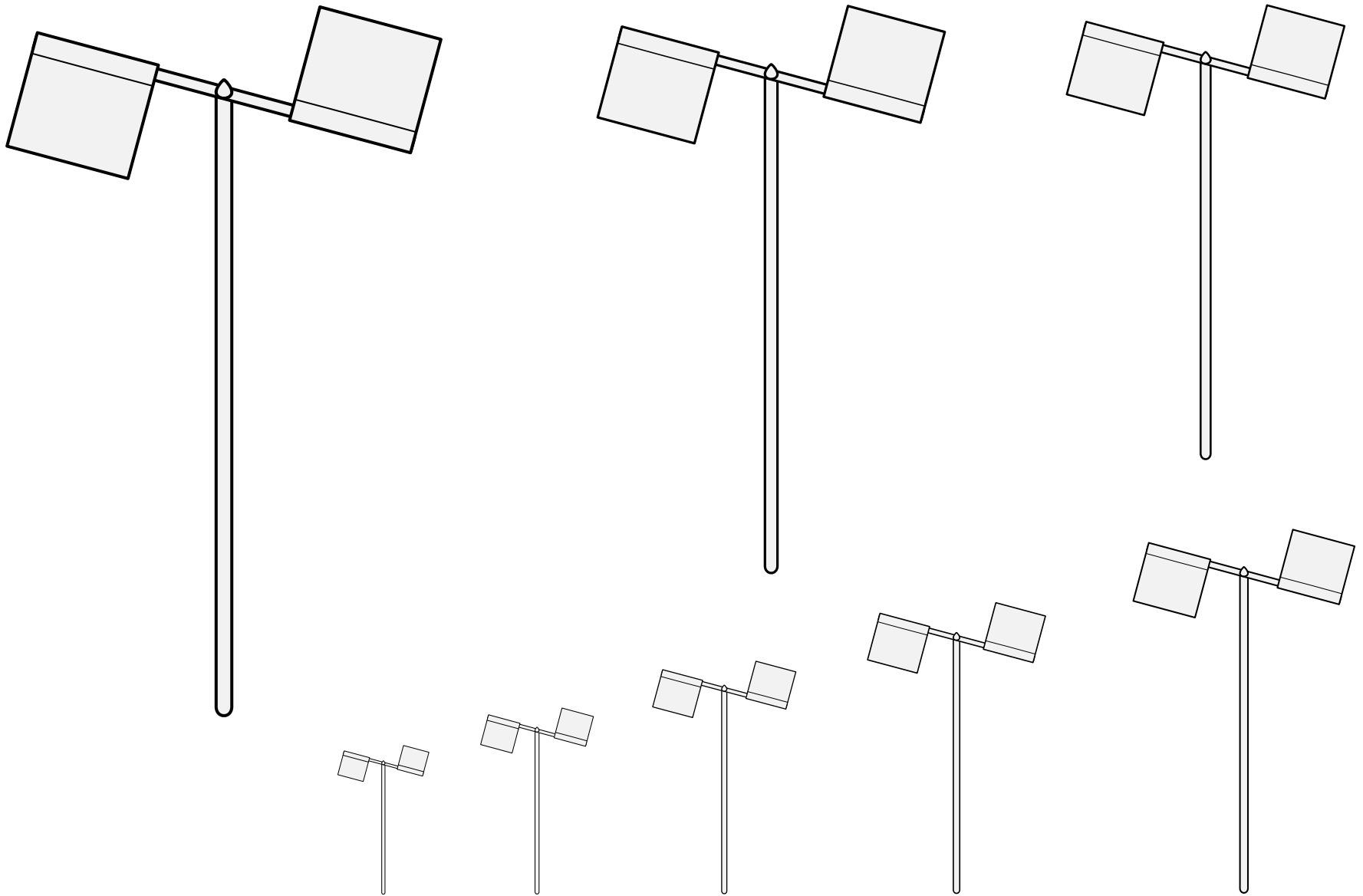

A spinning toy with a central shaft and lateral blades that catch the air.

Default orientation: upright. No proper coloration.

Source: Morgan Library MS M.1004. Artist unknown. (Fol 156v.)

Whirlingigig (2) 18.210

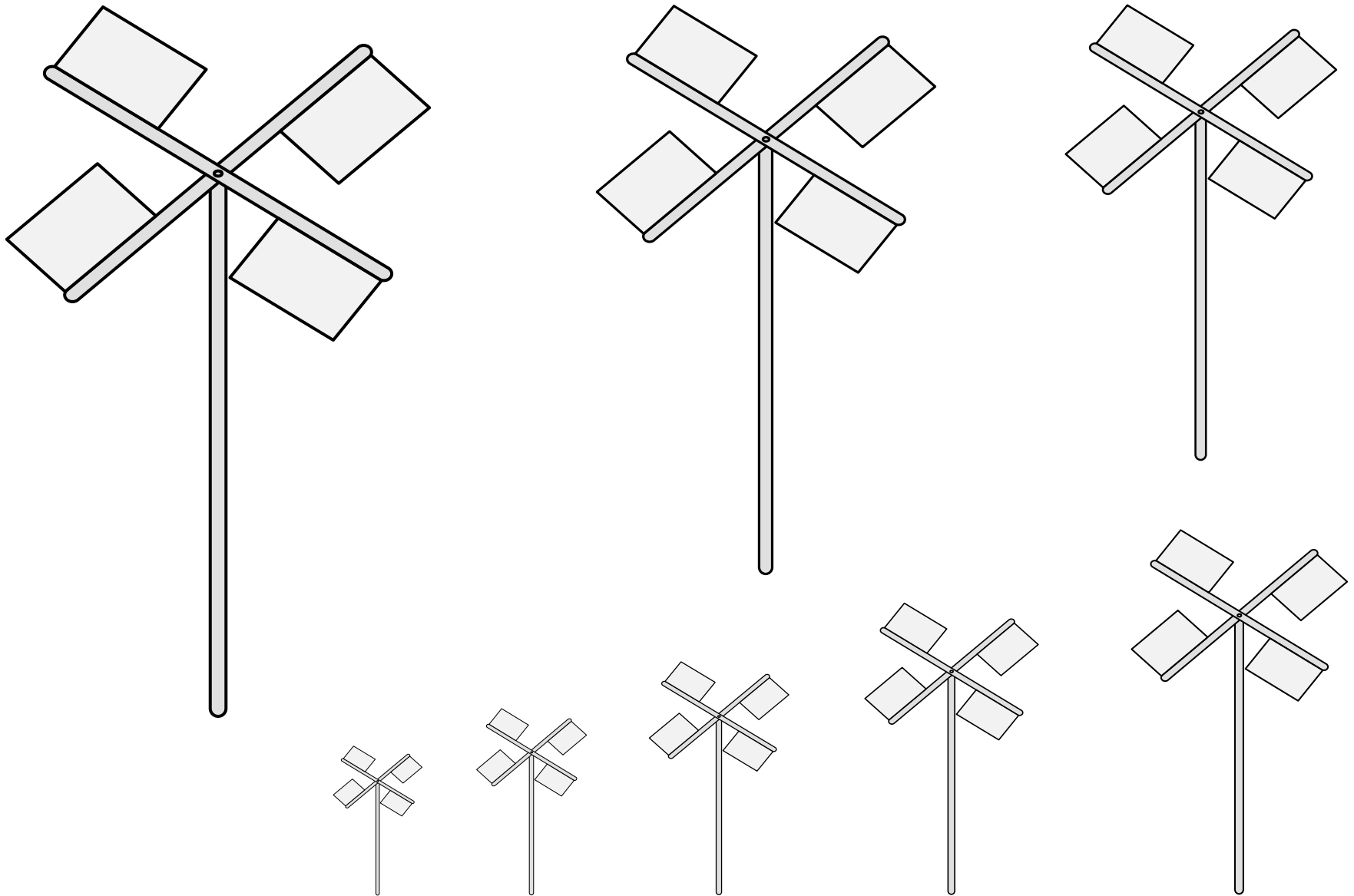

A spinning toy with a central shaft and lateral blades that catch the air.

Default orientation: upright. No proper coloration.

Source: Morgan Library MS M.919. Artist unknown. (Folio 131v.)

Whirligig (3) 18.211

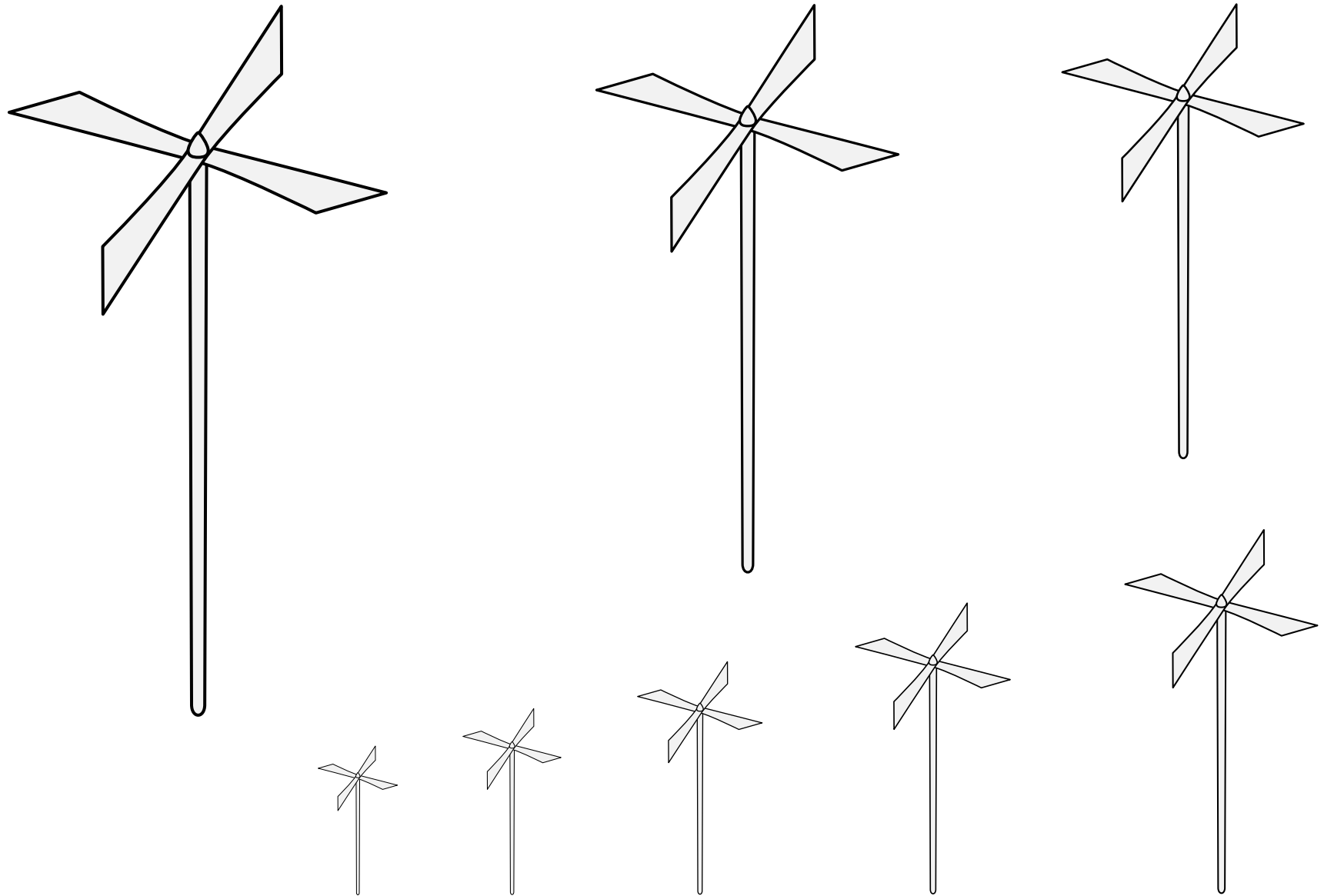

A spinning toy with a central shaft and lateral blades that catch the air.

Default orientation: upright. No proper coloration.

Source: Morgan Library MS G.7. Artist unknown. (Folio 222r.)

Whirlingig (4) • 18.212

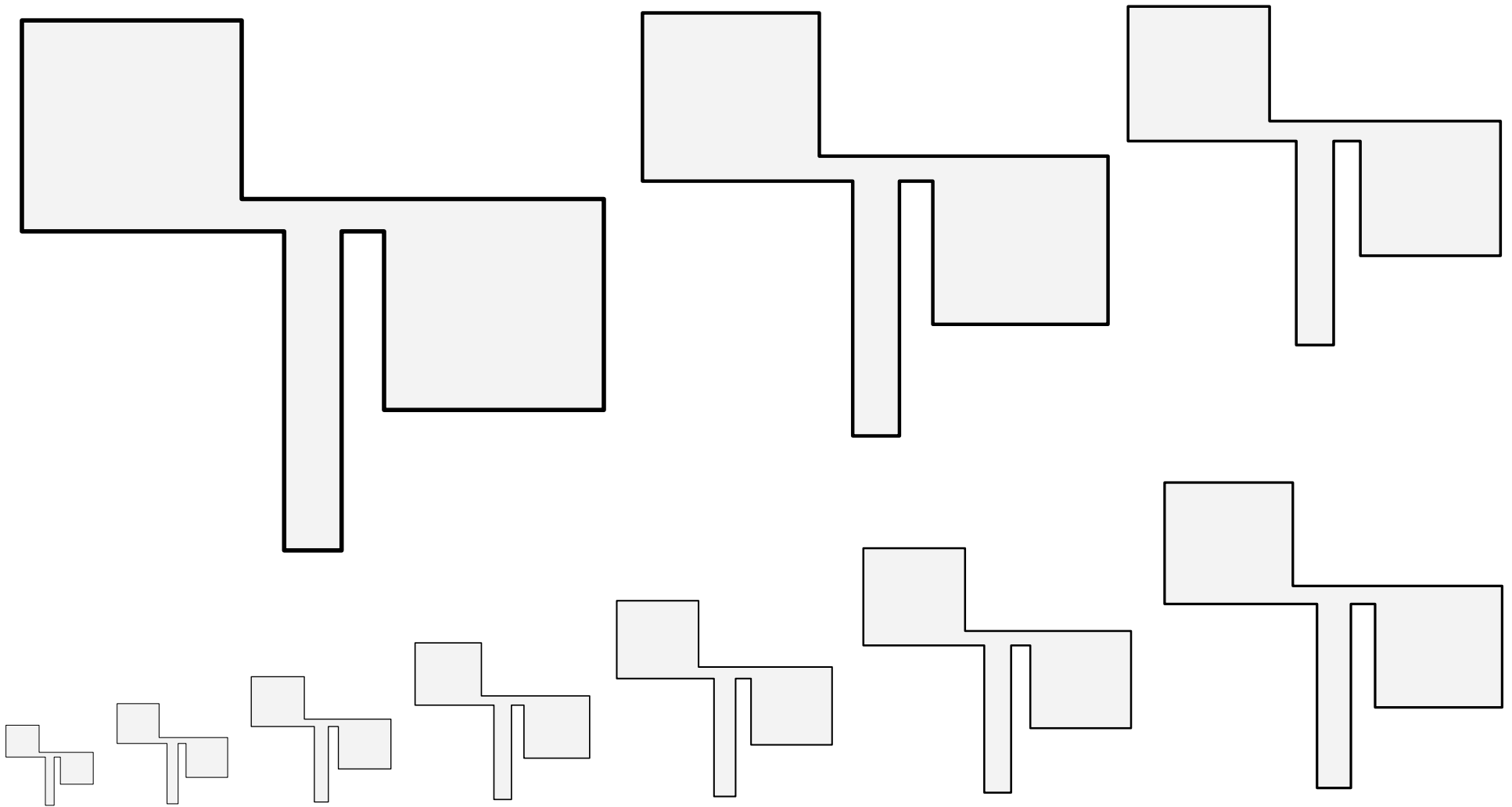

A spinning toy with a central shaft and lateral blades that catch the air.

Default orientation: upright. No proper coloration.

Source: Livre de la Recherche et du Recueil des Nobles du Bailliage de Saint-Mihiel et de Clermont. Artist: Didier Richier. (Folio 82v.) Adapted by Iago ab Adam.

Whirligig (5) 18.213

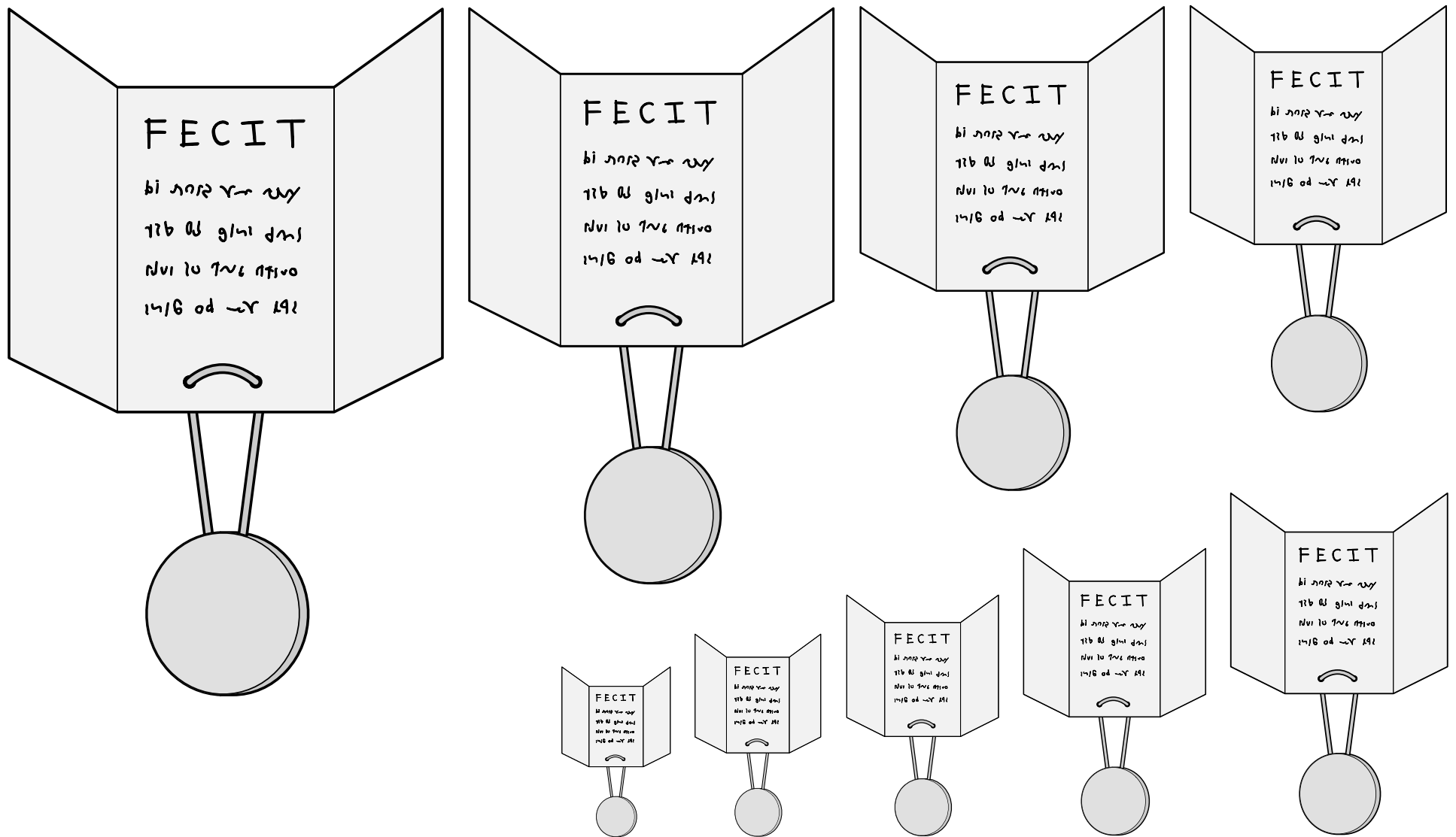

An official written proclamation.

Default orientation: upright. No proper coloration.

Source: Insegne di Vari Principi et Case Illustri d'Italia.

Artist: Giacomo Fontana. (Folio 57r.)

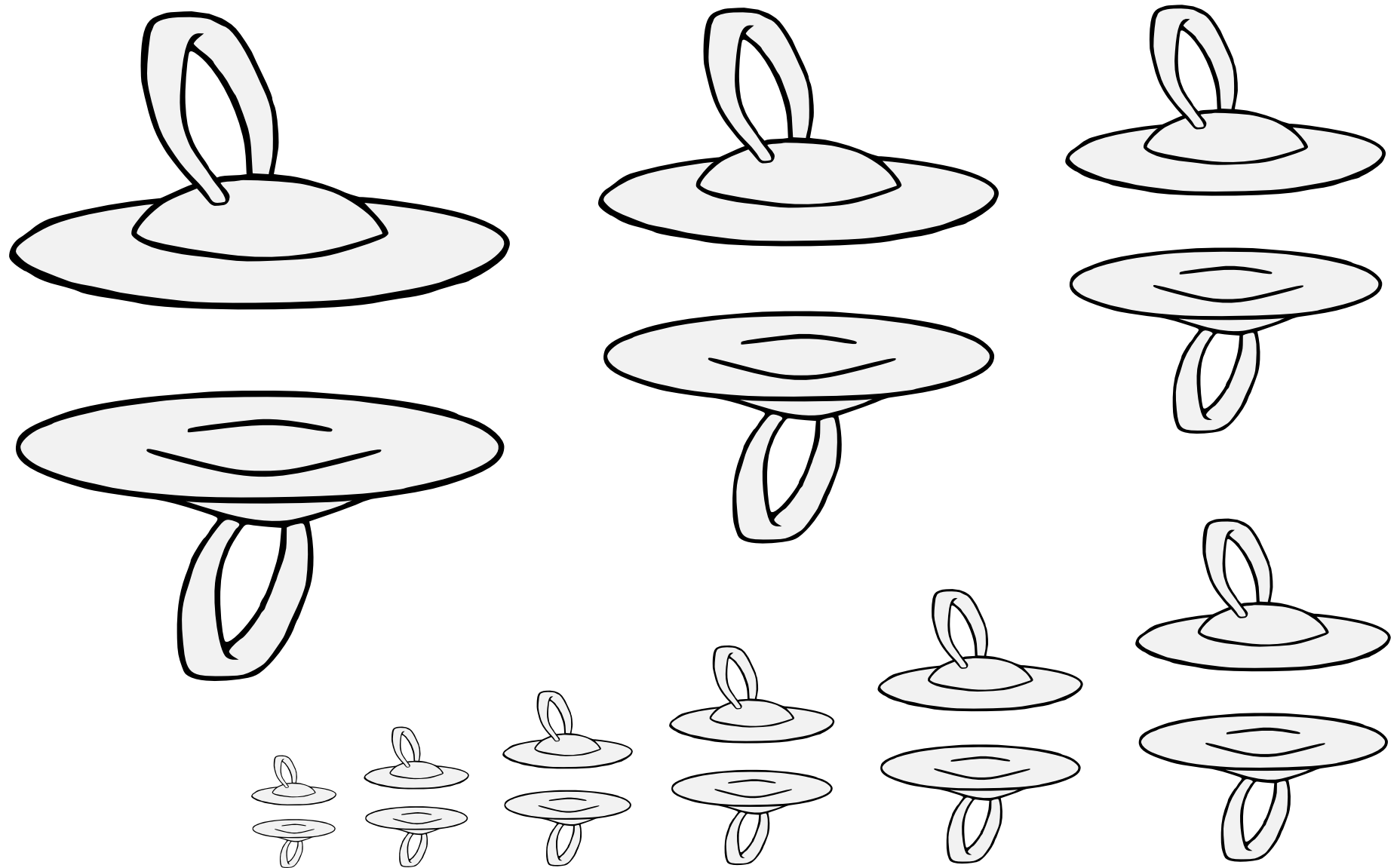

Small cymbals worn on one's fingers.

Default orientation: strap to chief, or a pair facing each other. No proper coloration.

Artist: Jessimond of Emerickeskepe.

Zills, Pair of 18.215

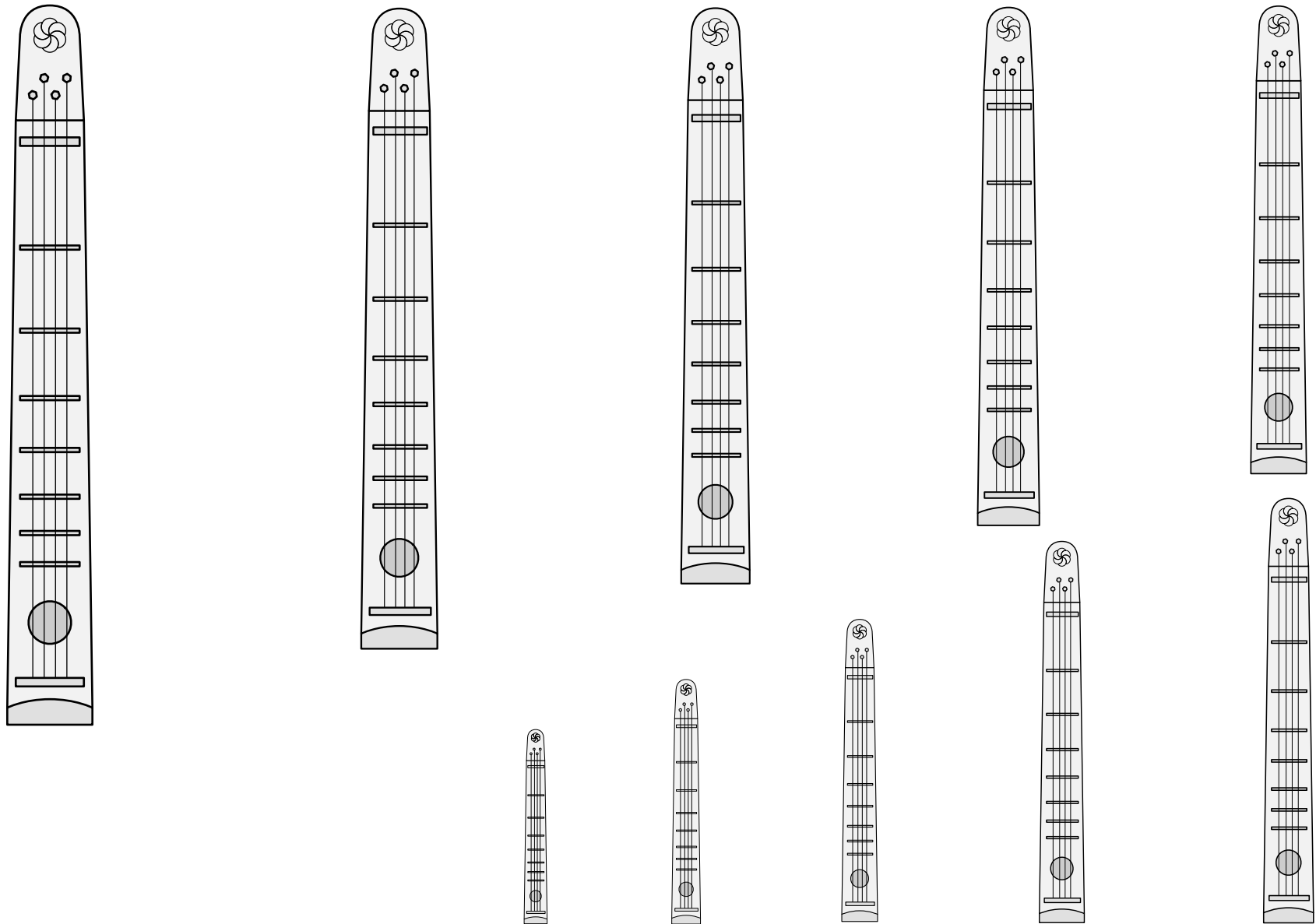

A Renaissance-era string instrument, played by strumming or hammering the strings.