

❧ Book of Traceable Heraldic Art ❧

Volume 19:

Farming

Including Agricultural Products,
Hunting, & Animal Husbandry

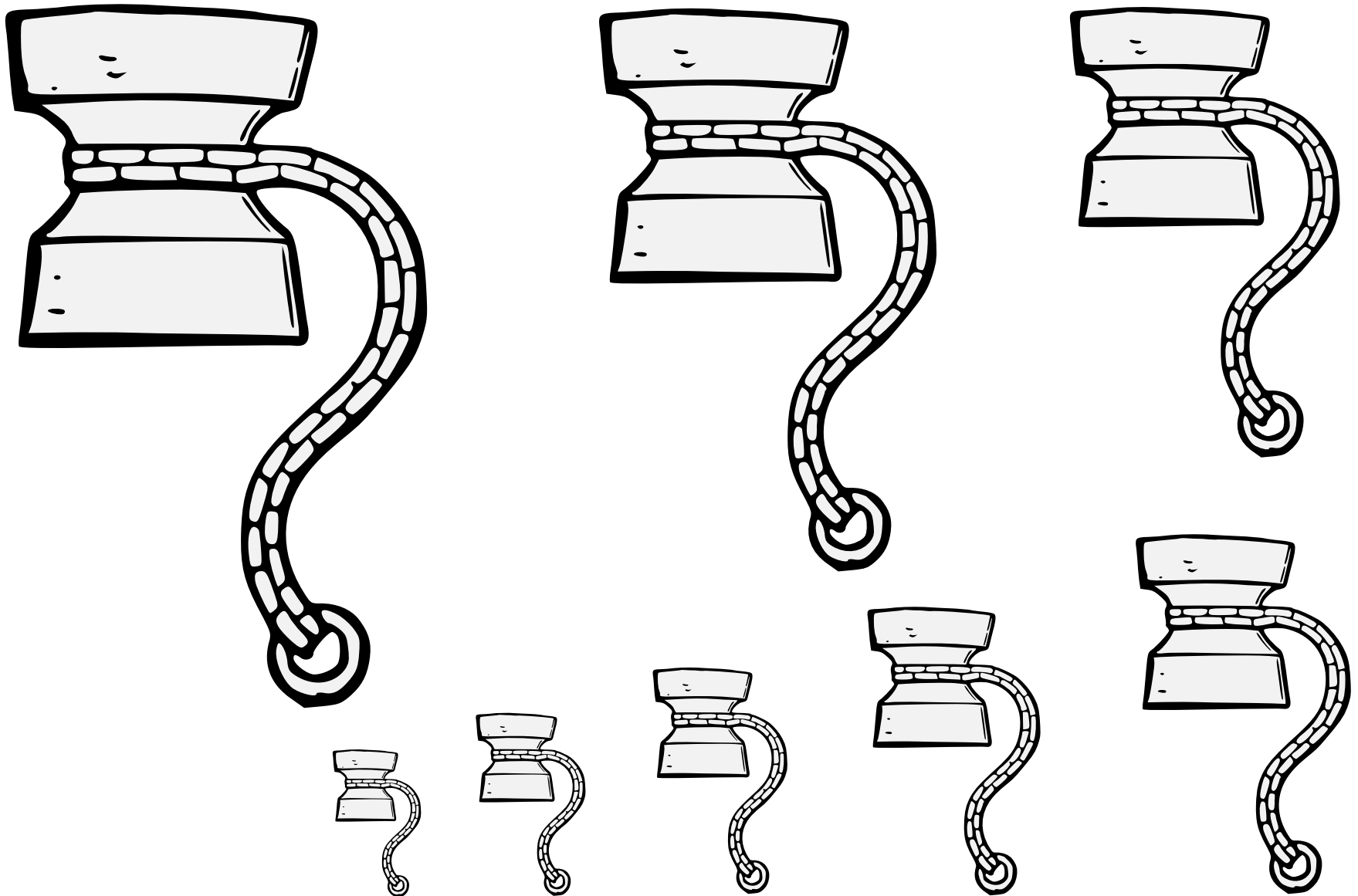

An anchoring plinth and chain to which a captured ape could be attached.

Default orientation: clog palewise. No proper coloration.

Source: A Complete Guide to Heraldry. Artist: Graham Johnston.

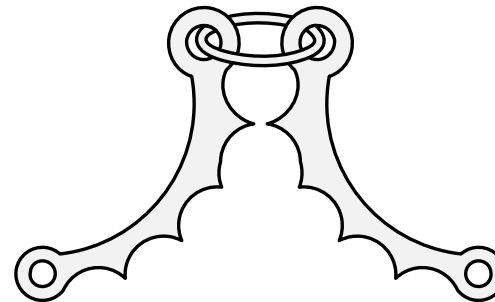
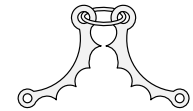
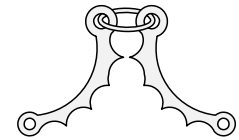
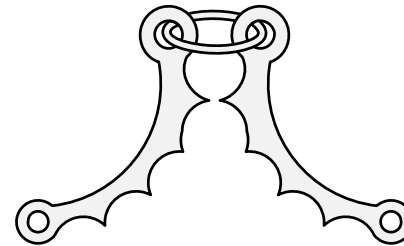
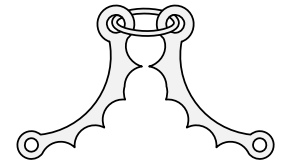
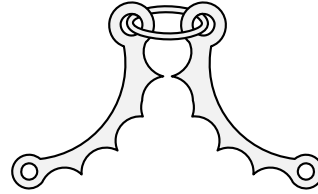
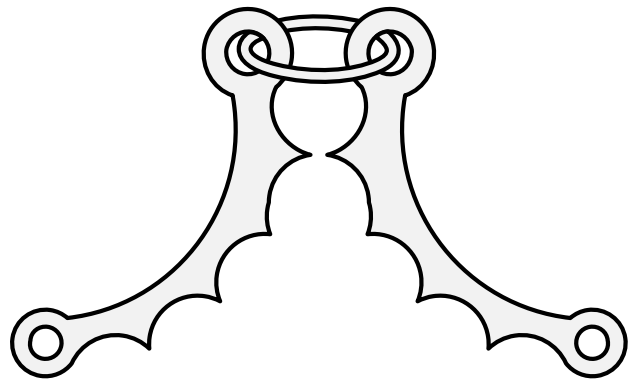
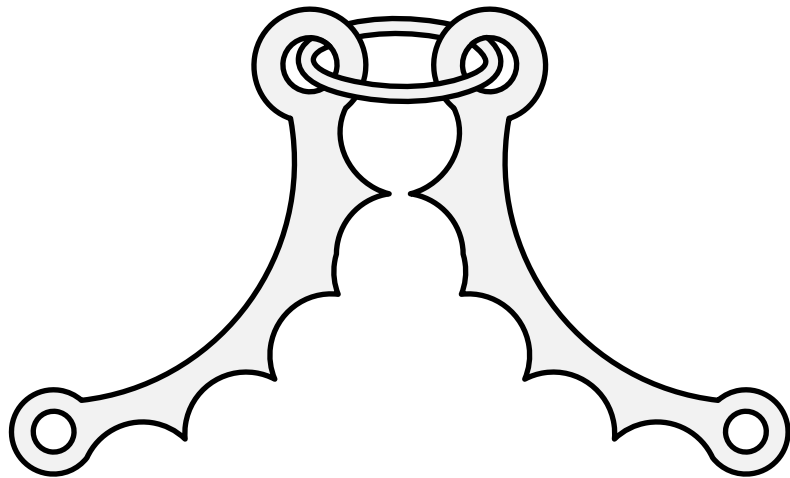

A mechanism for pinching the nose of a feisty horse to quiet it.

Default orientation: hinge to chief. No proper coloration.

Source: Bergshammar Armorial. Artist unknown.

Adapted by Mathghamhain Ua Ruadháin.

Barnacles, Pair of (1) 19.3

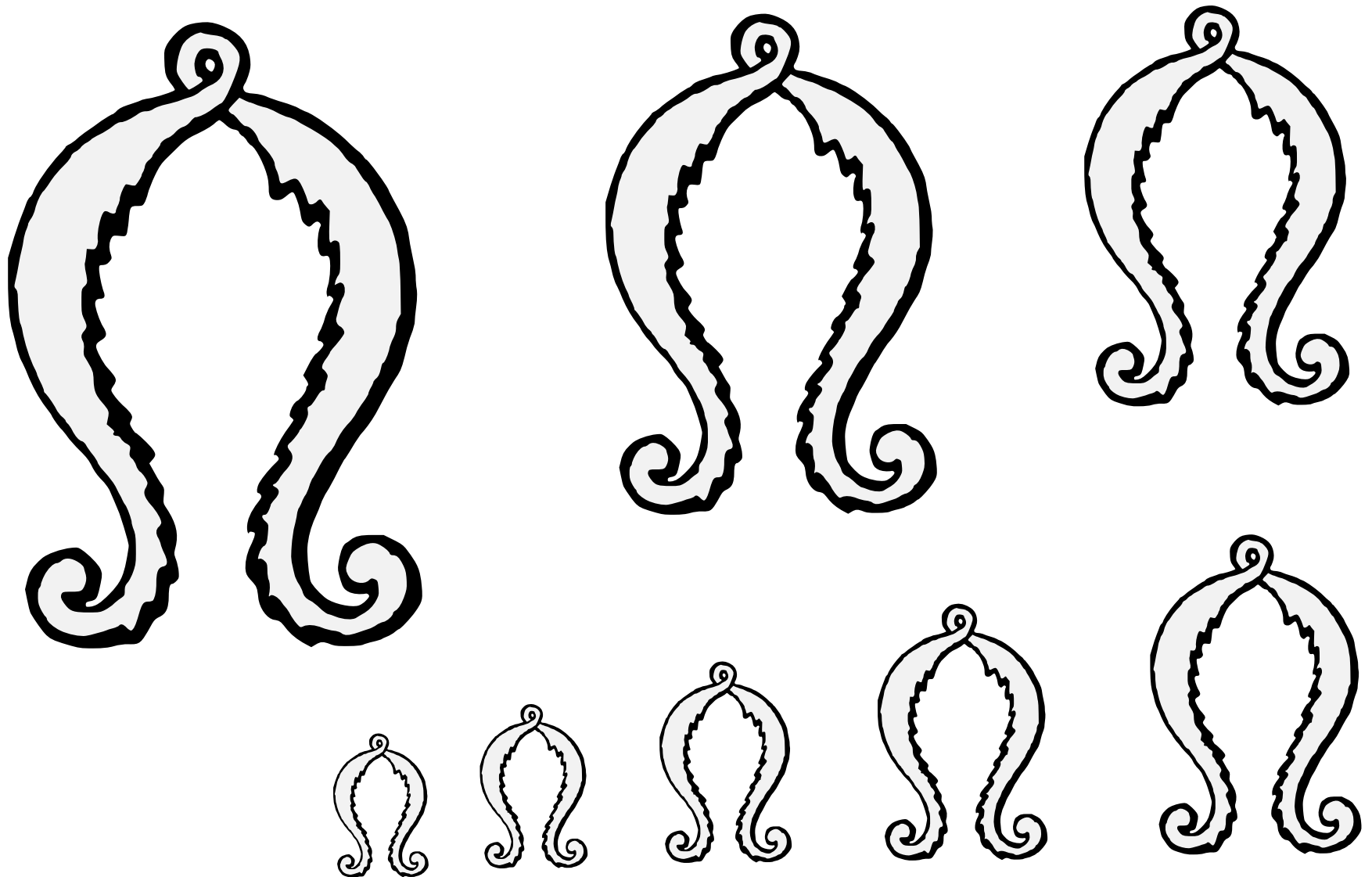

A mechanism for pinching the nose of a feisty horse to quiet it.
Default orientation: hinge to chief. No proper coloration.
Source: A Treatise on Heraldry British and Foreign. Artist unknown.

Barnacles, Pair of (2) 19.4

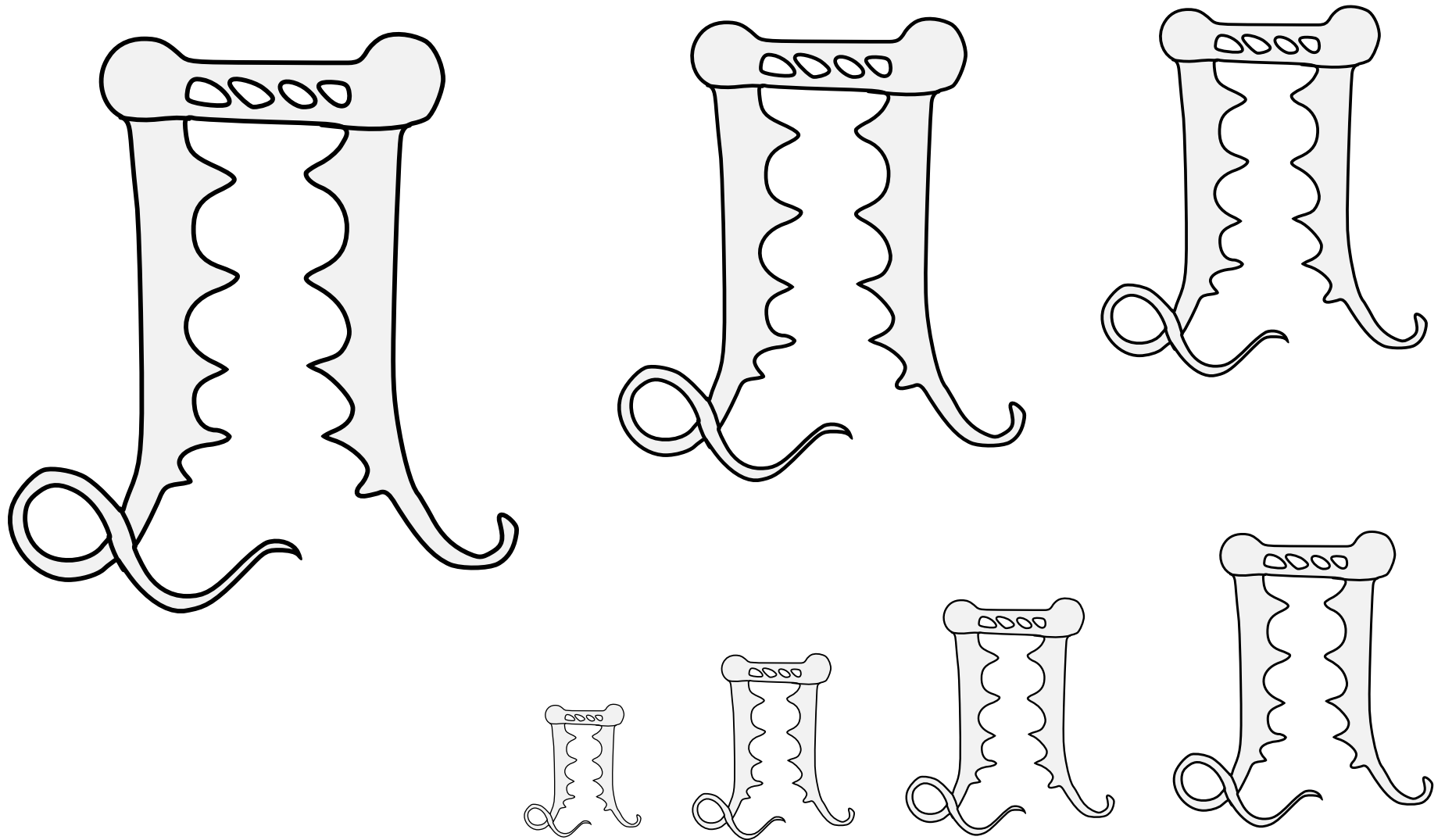

A mechanism for pinching the nose of a feisty horse to quiet it.

Default orientation: hinge to chief. No proper coloration.

Source: Two Tudor Books of Arms. Artist: Robert Cooke.
(From page 151, arms of Wylim Barnake.)

Barnacles, Pair of (3) 19.5

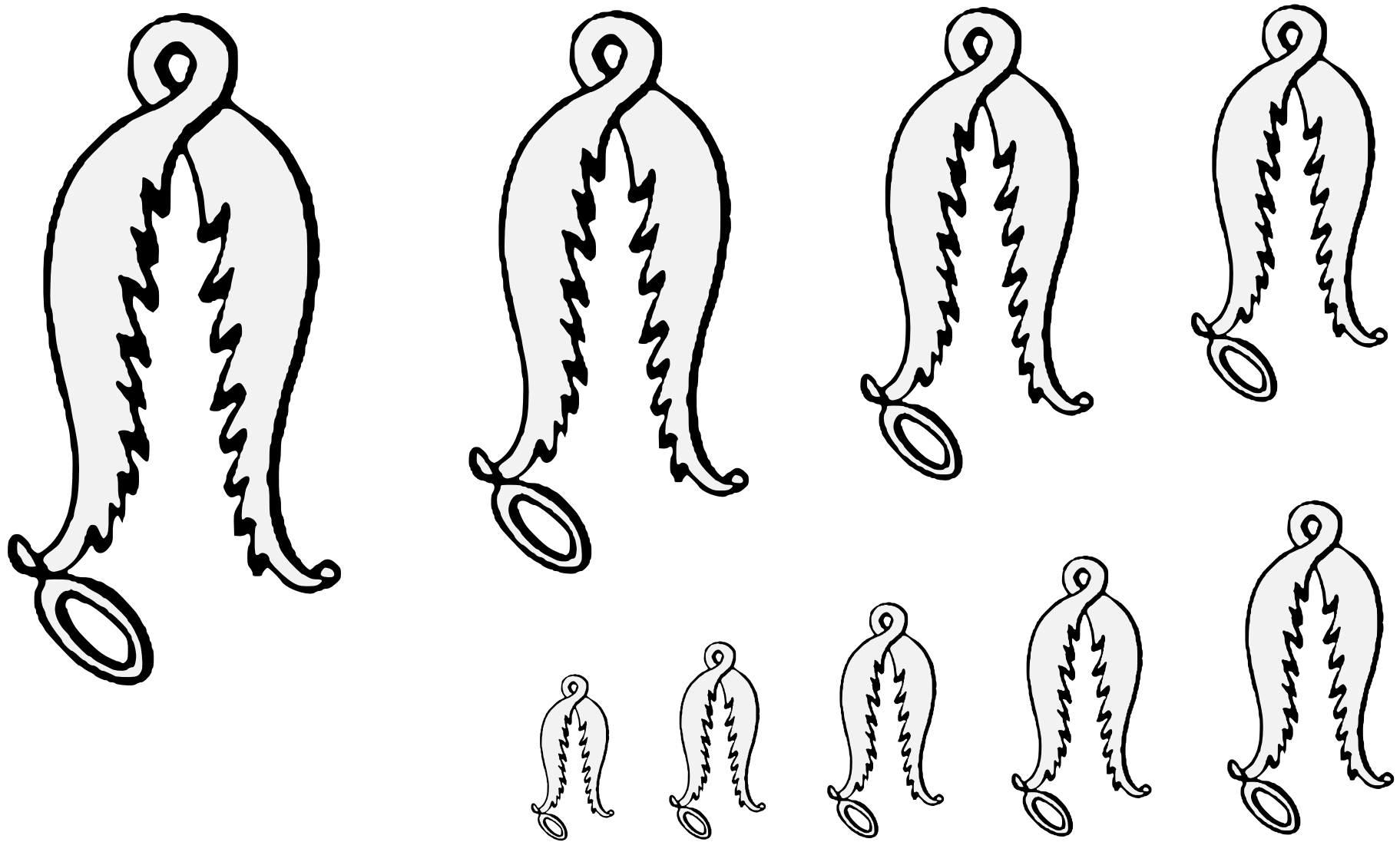

A mechanism for pinching the nose of a feisty horse to quiet it.
Default orientation: hinge to chief. No proper coloration.
Source: Encyclopædia Heraldica. (Volume 3, plate IX.) Artist unknown.

Barnacles, Pair of (4) 19.6



A mechanism for pinching the nose of a feisty horse to quiet it.

Default orientation: hinge to chief. No proper coloration.

Source: Encyclopædia Heraldica.
(Volume 3, plate IX.) Artist unknown.

Barnacles, Pair of, Extended 19.7

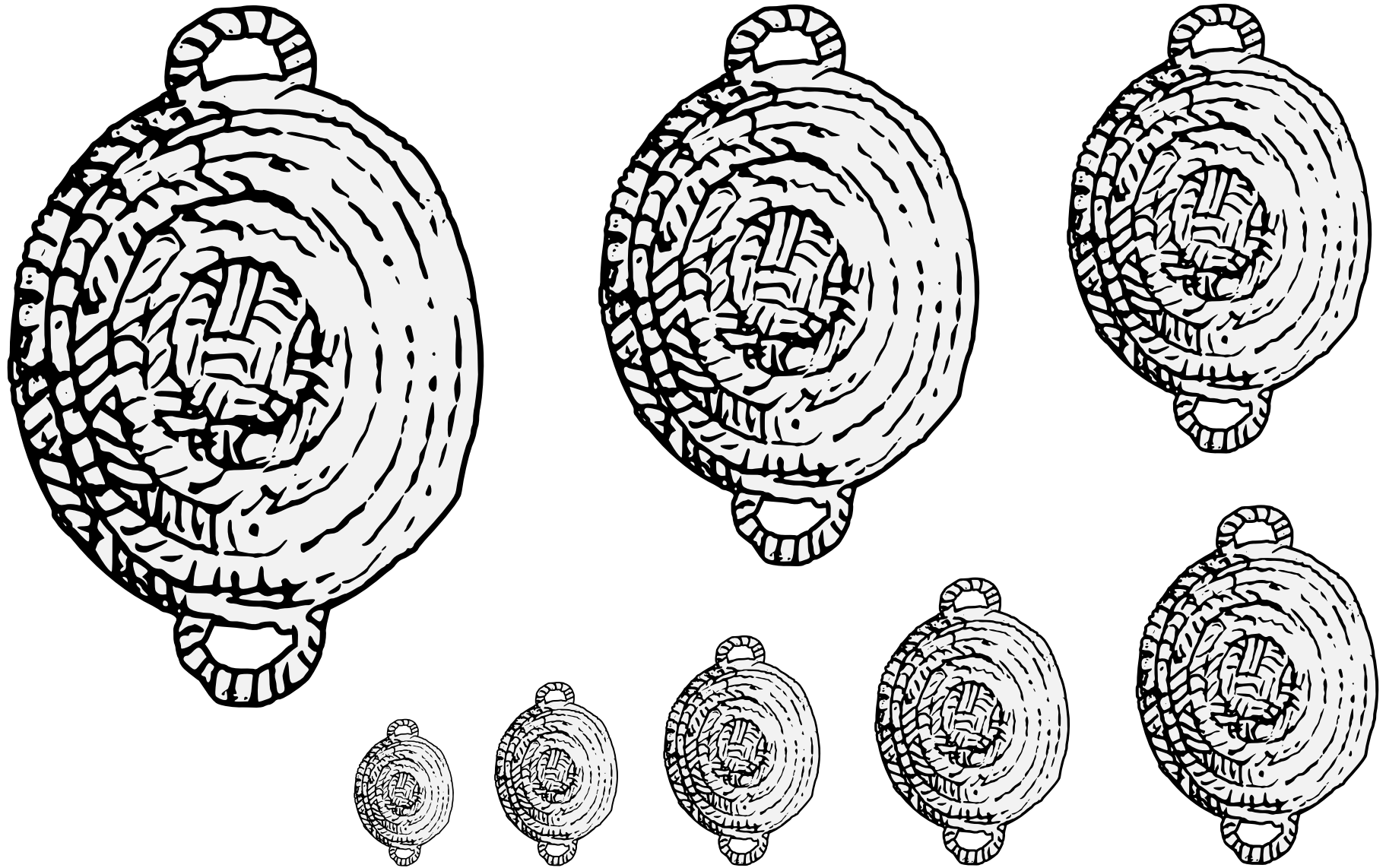

A hand-held breeze-maker used to separate grains of wheat from their accompanying chaff.

Default orientation: handle to chief. No proper coloration.

Source: Wappenbuch der Arlberg-Bruderschaft.
Artist: Vigil Raber. (Page 323.)

Basket, Winnowing 19.8

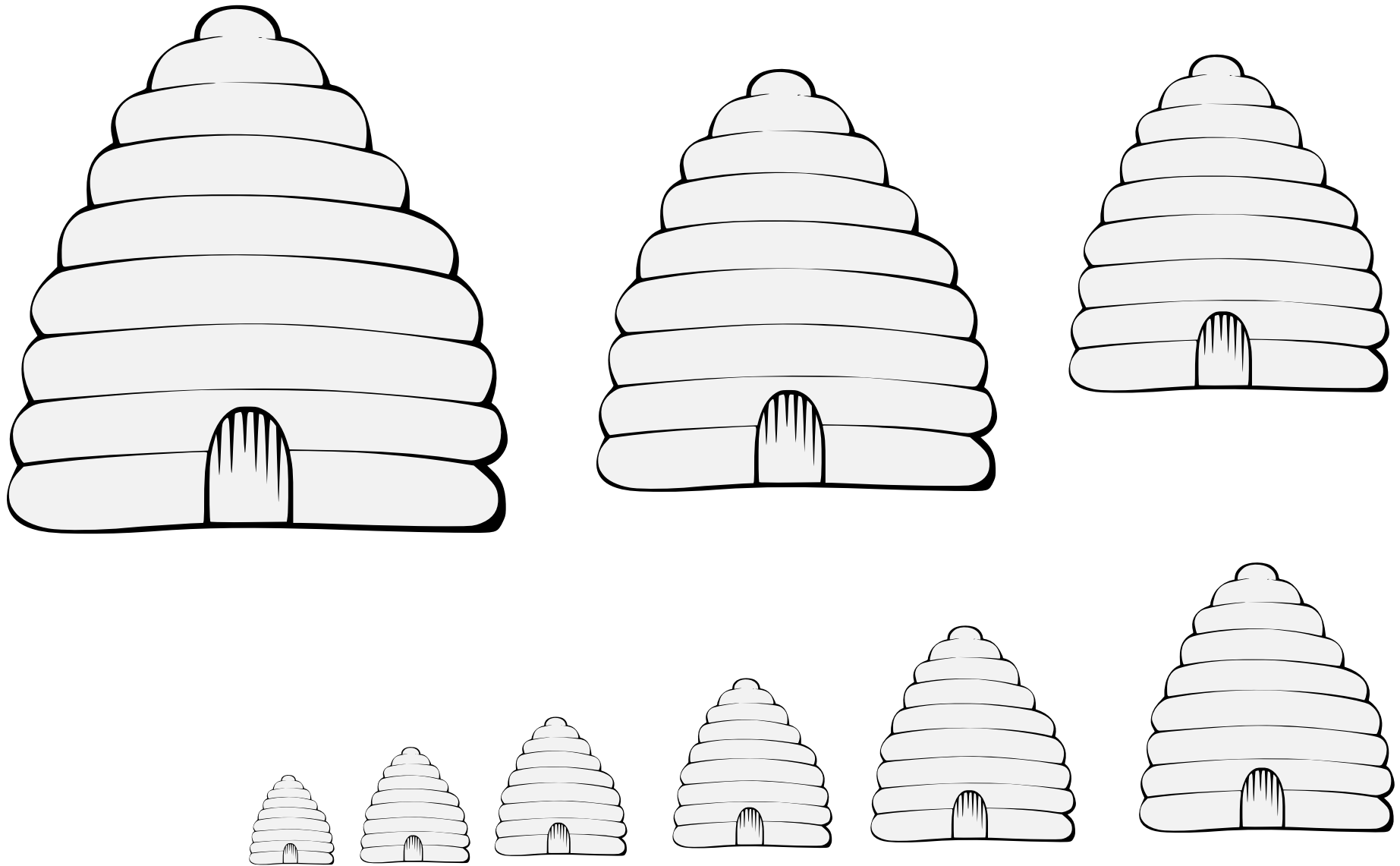

The home formed by a colony of bees.

Default orientation: upright. No proper coloration.

Source: Pennsic Traceable Art Archives. Artist: Ian Raven of Tadcaster.

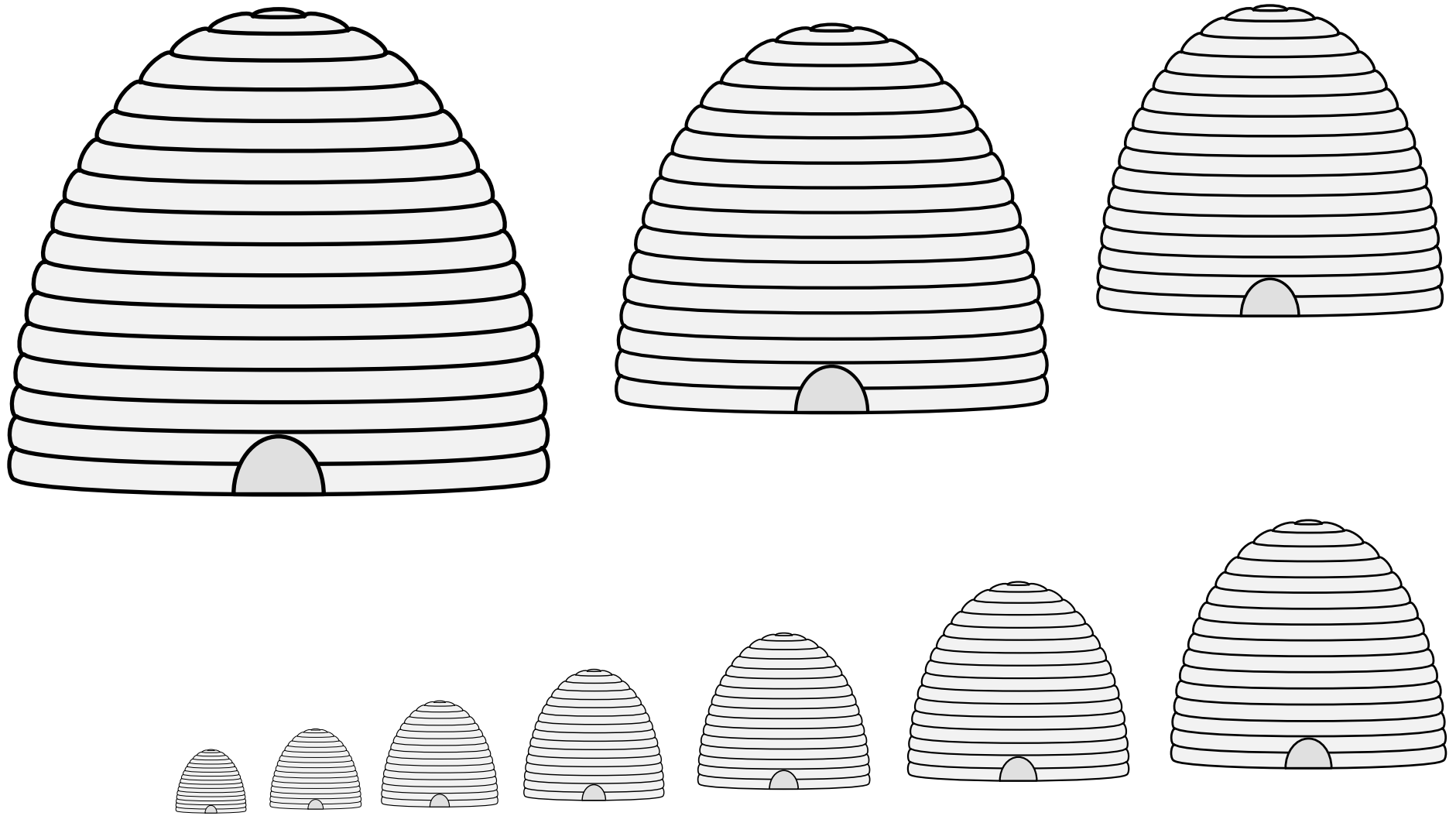

Medieval beekeepers used inverted baskets called "skeps" to house their hives.
Default orientation: upright. No proper coloration.

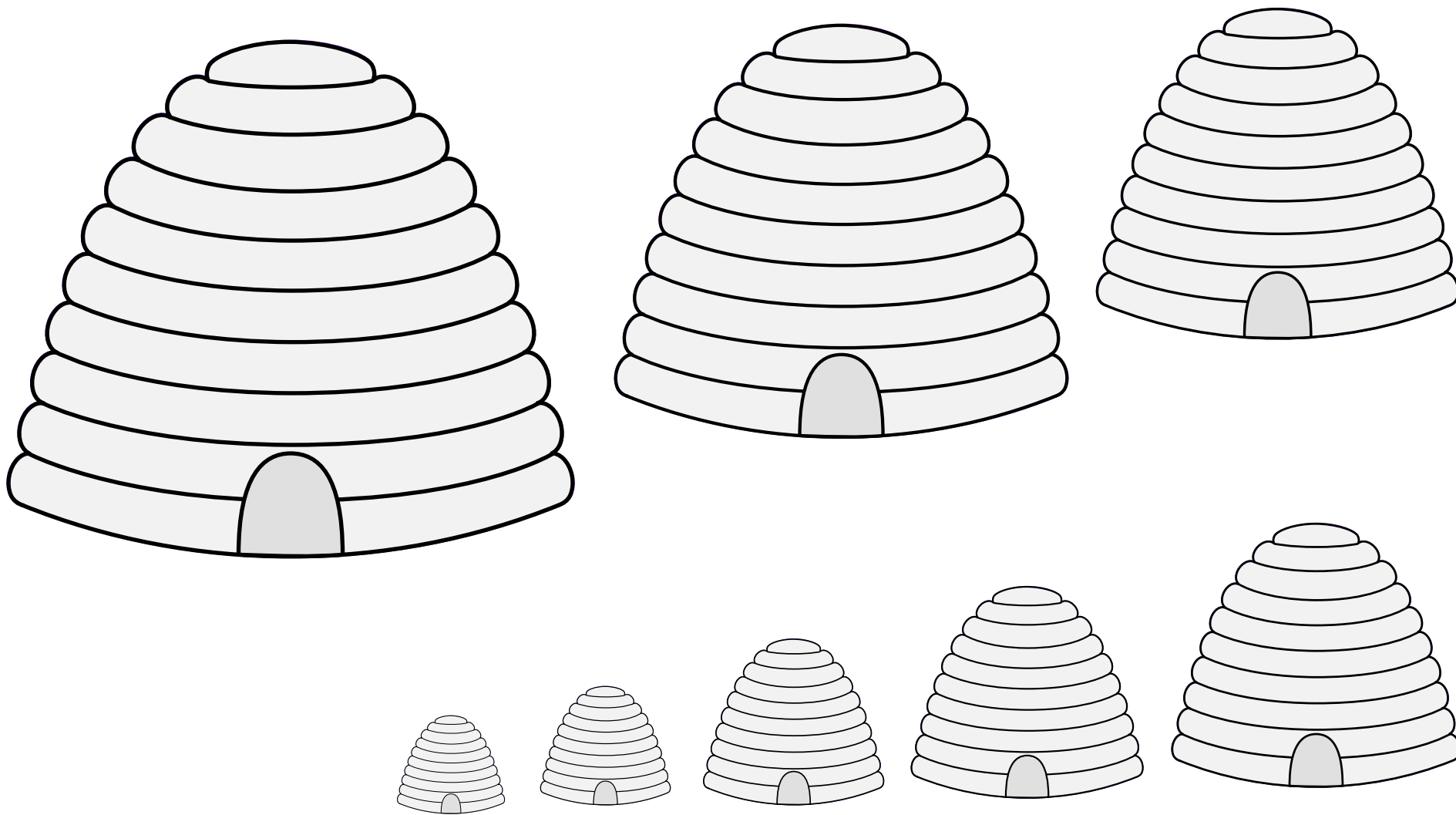

Medieval beekeepers used inverted baskets called “skeps” to house their hives.
Default orientation: upright. No proper coloration.

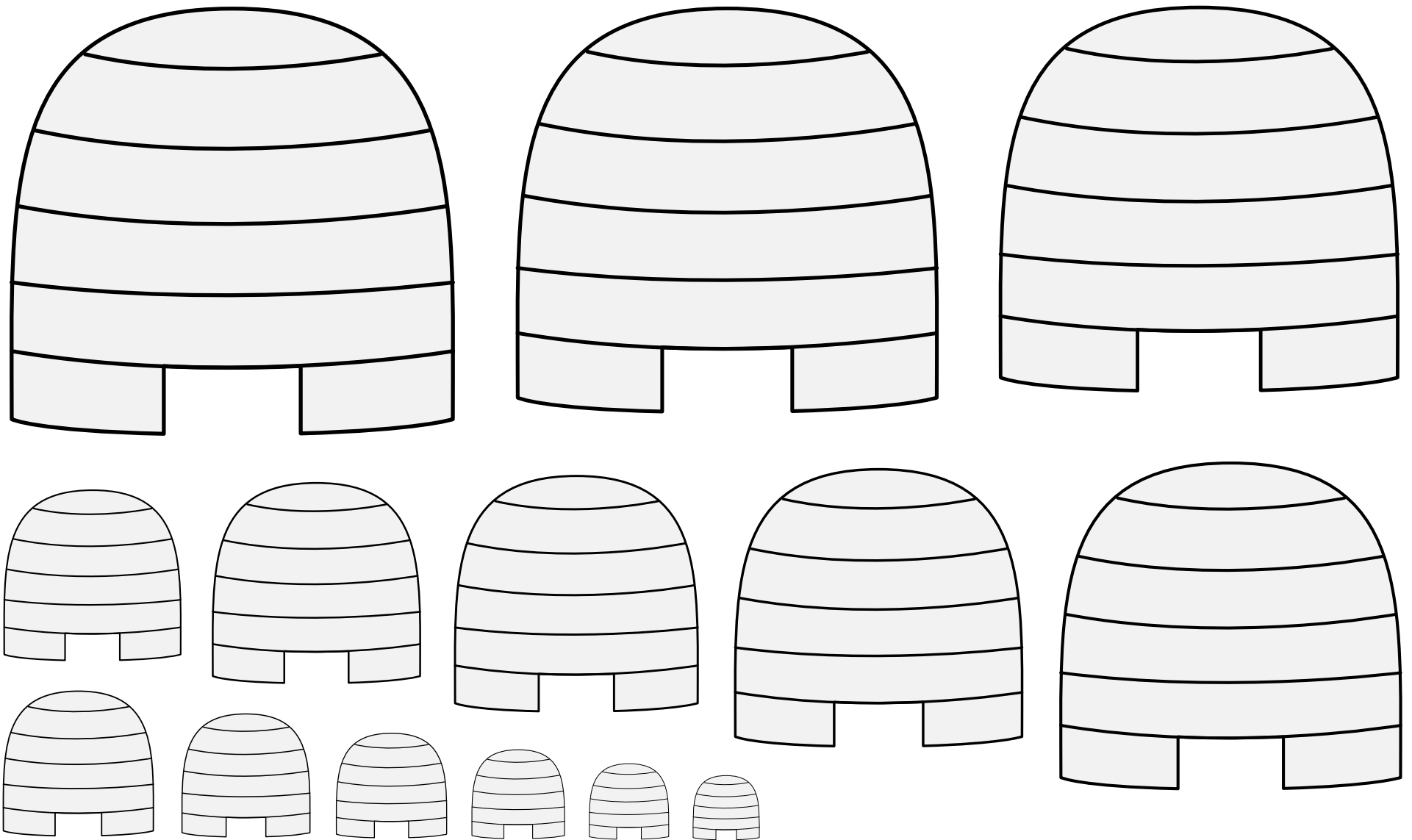

Medieval beekeepers used inverted baskets called “skeps” to house their hives.

Default orientation: upright. No proper coloration.

Source: Wappenbuch der Arlberg-Bruderschaft. Artist: Vigil Raber. (Page 226.)

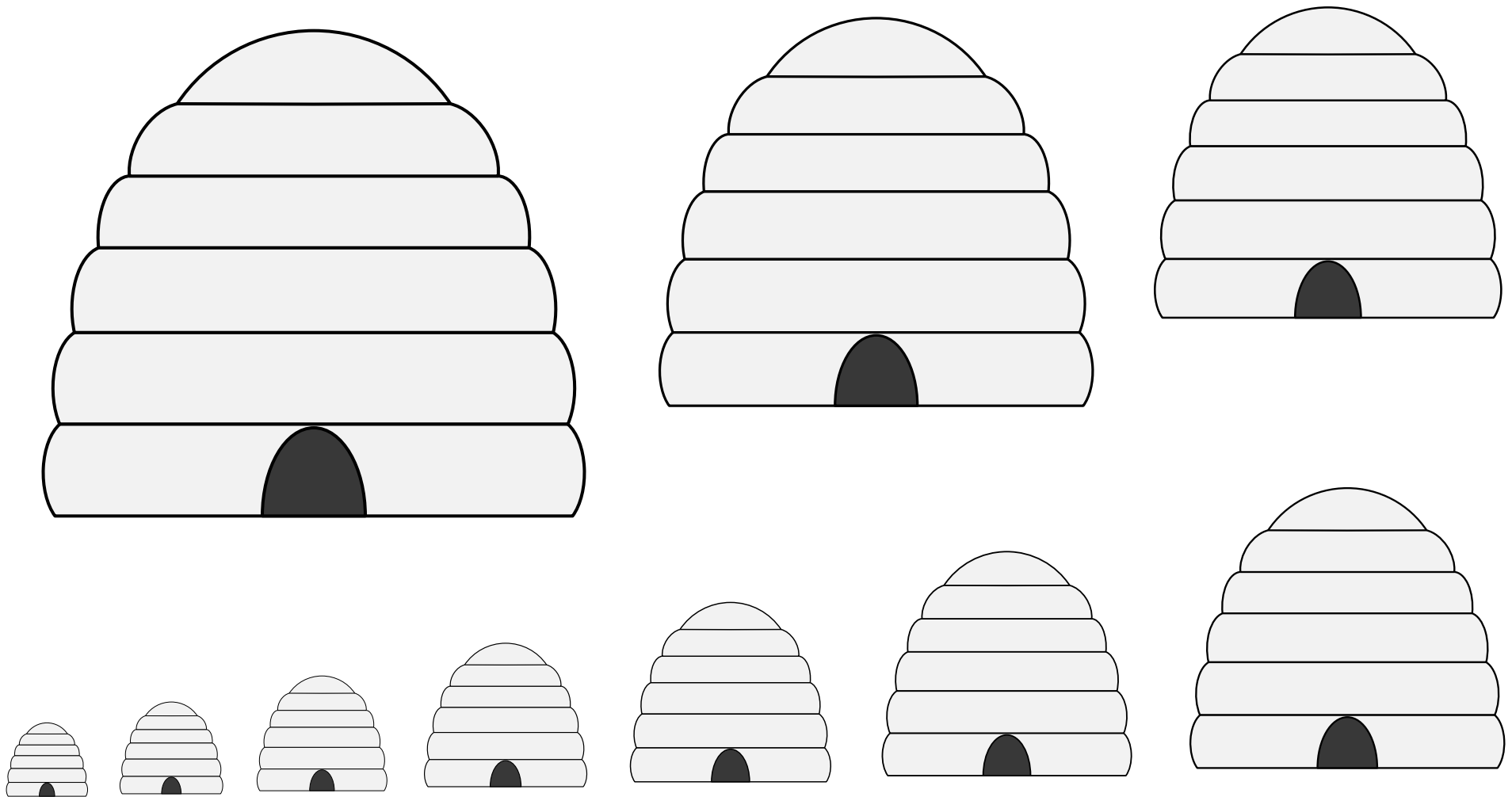

Medieval beekeepers used inverted baskets called “skeps” to house their hives.

Default orientation: upright. No proper coloration.

Source: Viking Answer Lady SVG Images For Heraldry.

Artist: Gunnvôr silfrhárr.

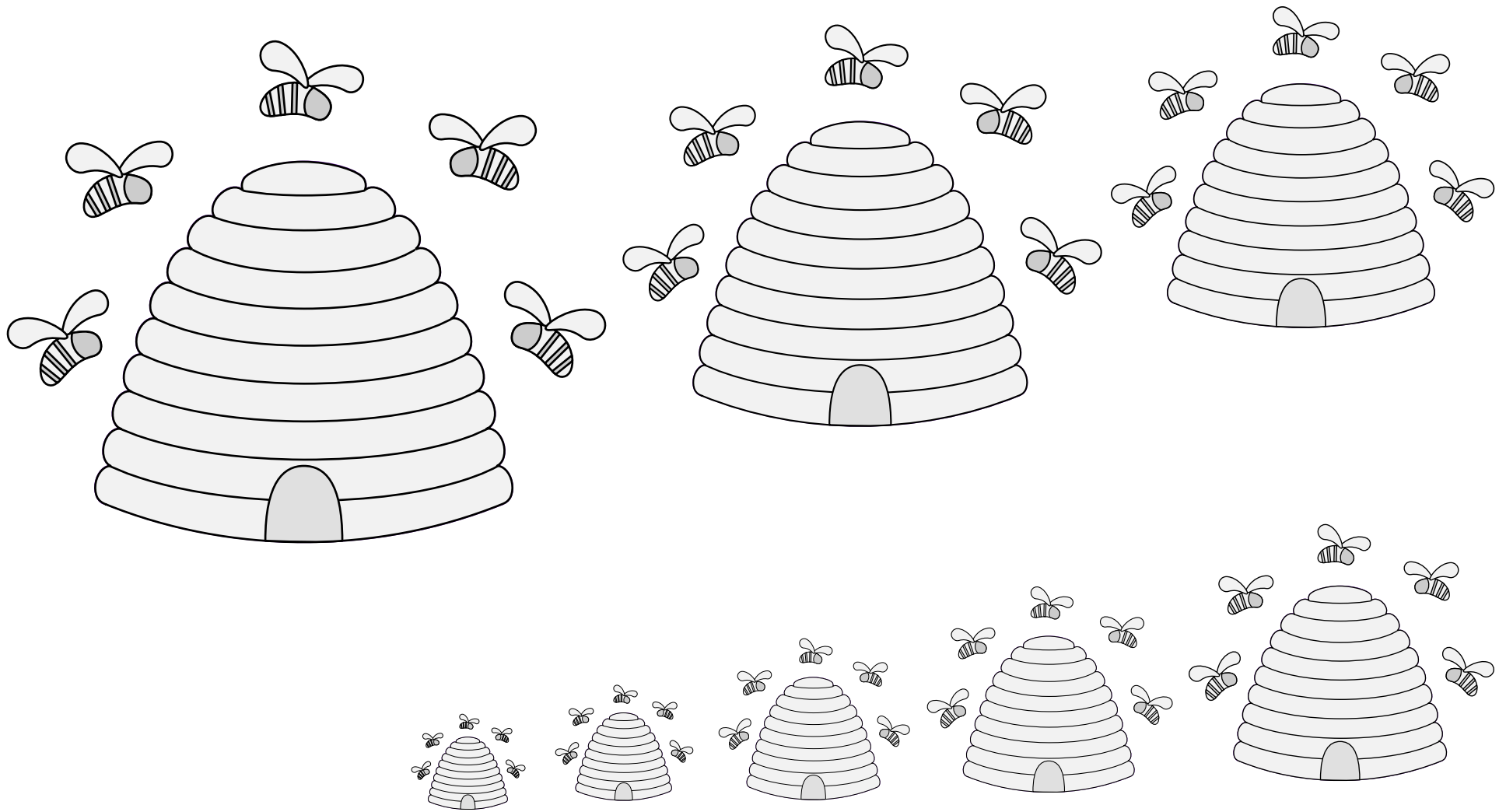

Medieval beekeepers used inverted baskets called “skeps” to house their hives.

Default orientation: upright. No proper coloration.

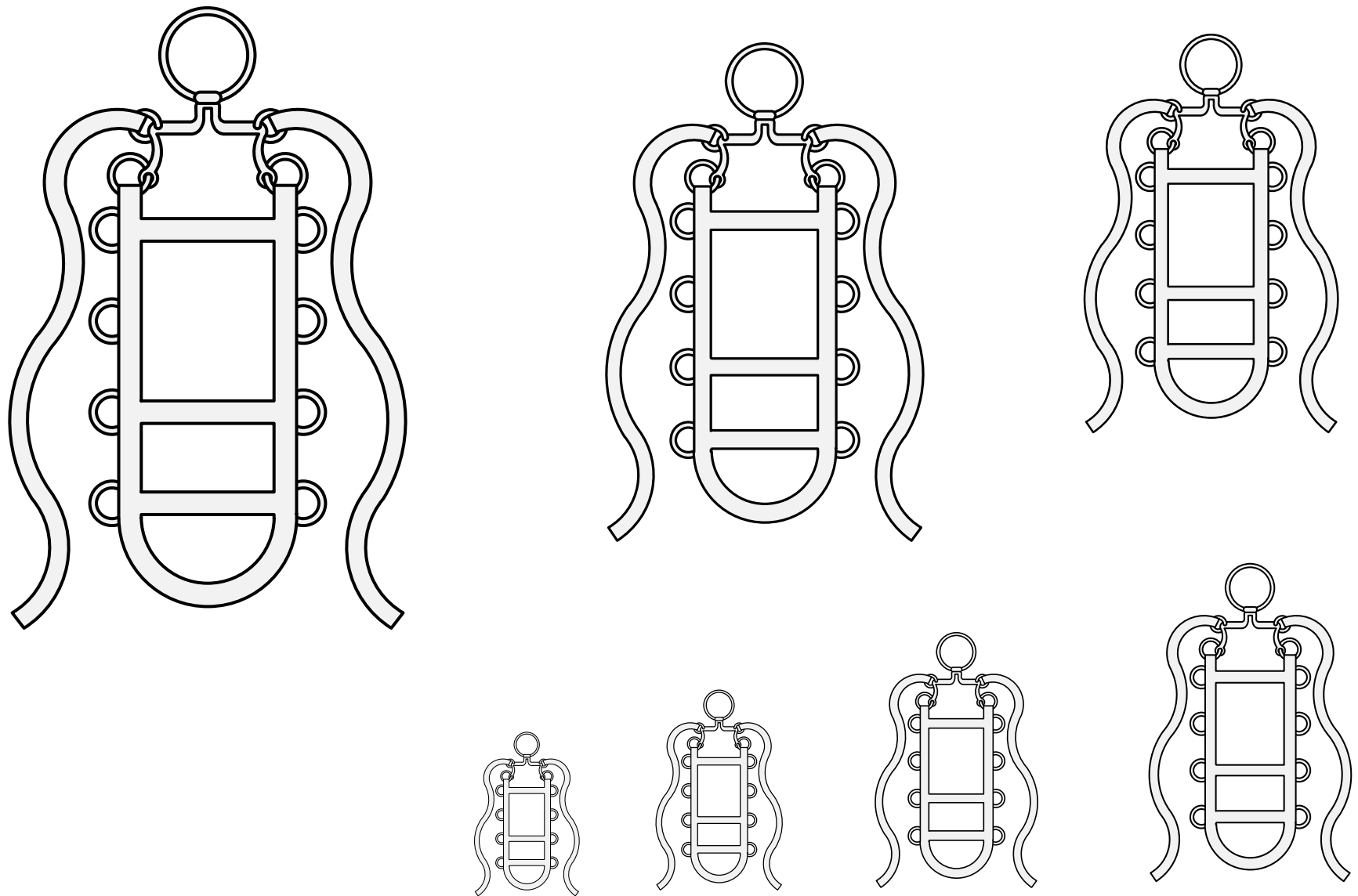

A harness for controlling a horse's head.

Default orientation: bit to chief. No proper coloration

Source: Viking Answer Lady SVG Images For Heraldists. Artist: Gunnvôr silfrhárr.

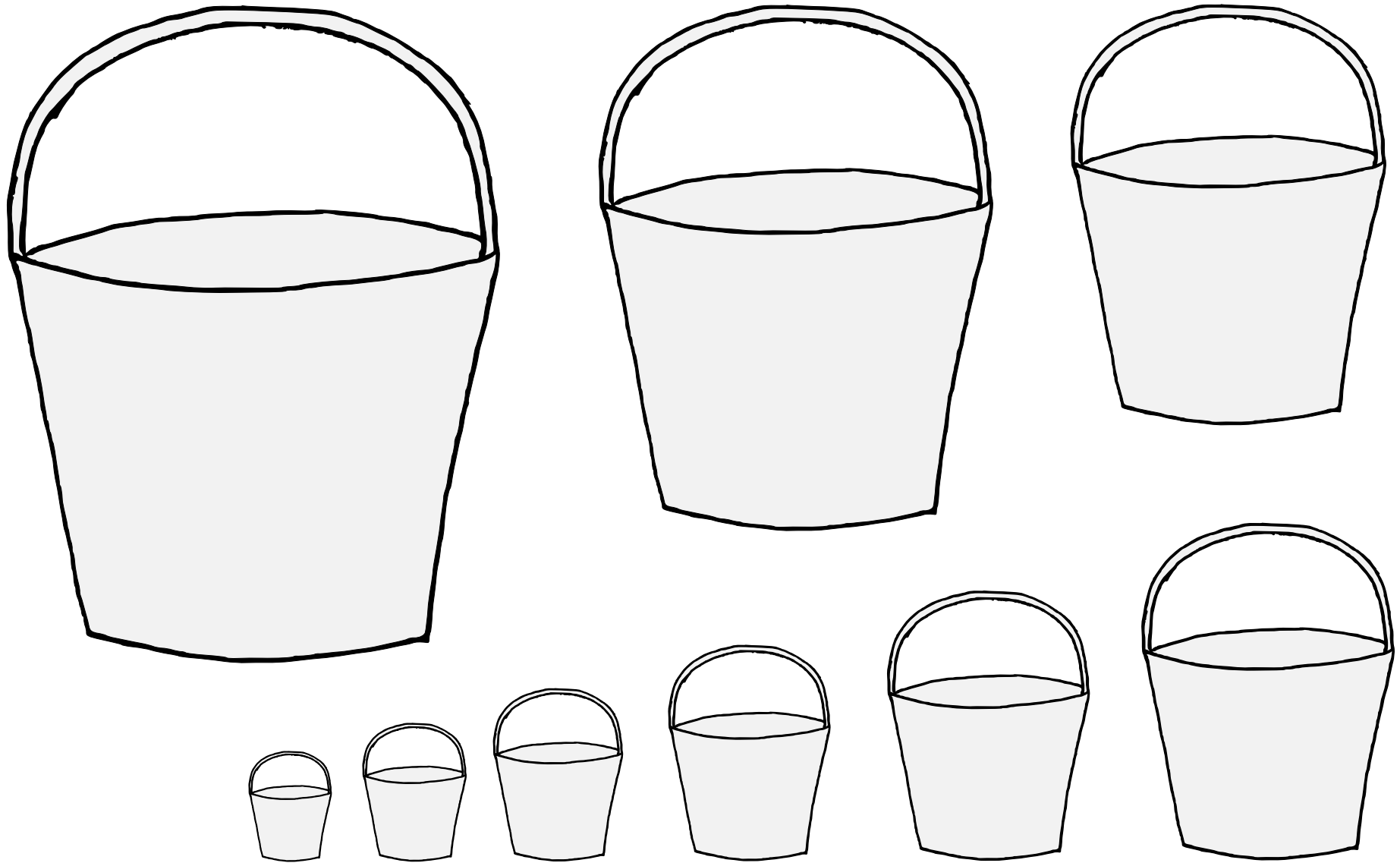

A container for carrying water, with a flat bottom and a curved handle.
Default orientation: handle to chief. Proper coloration: brown wood.
Source: Pennsic Bored-Artist Collection. Artist: Kjalvor Sæbjarnardottir.

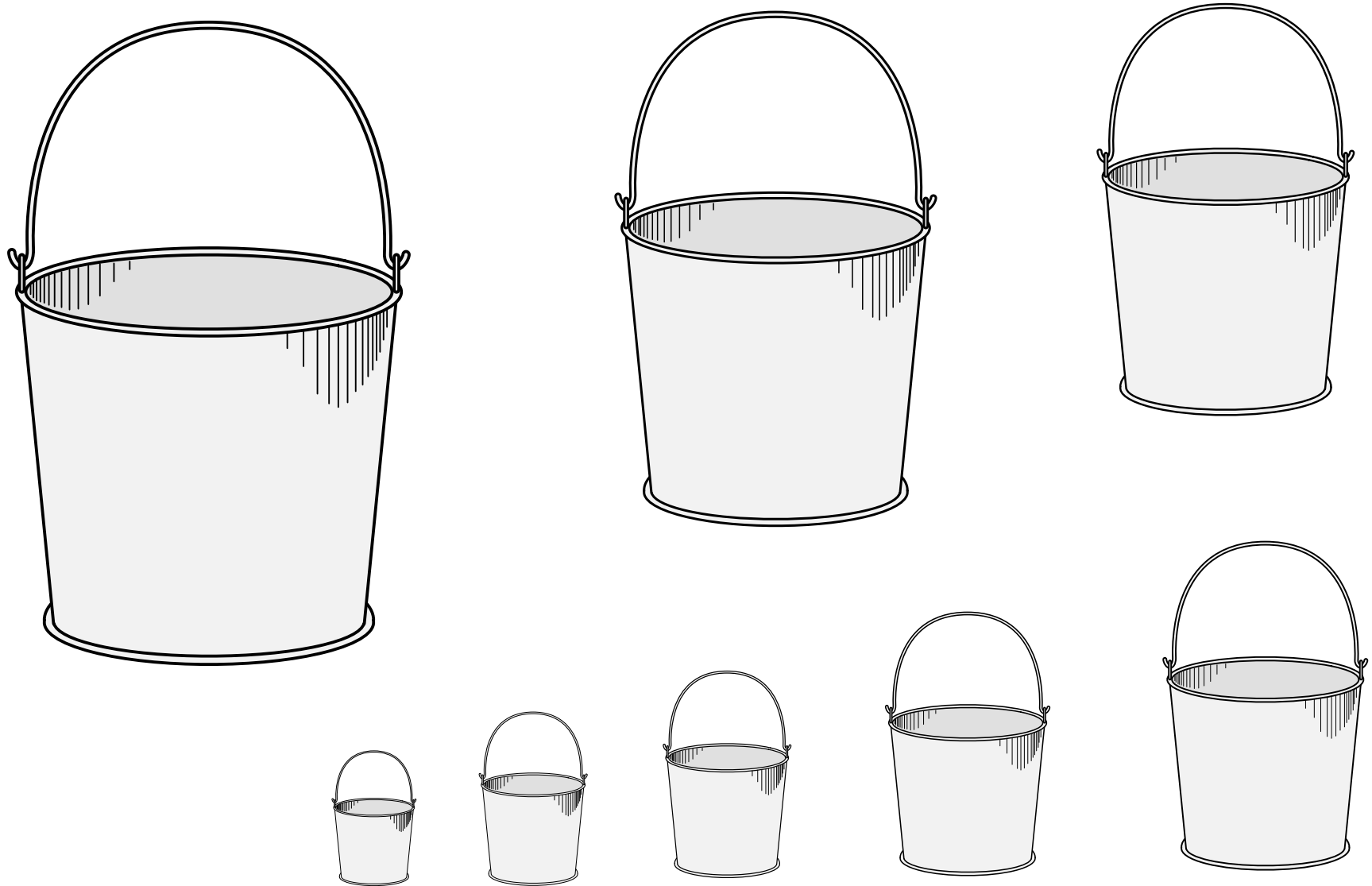

A container for carrying water, with a flat bottom and a curved handle.
Default orientation: handle to chief. Proper coloration: brown wood.

Bucket (2) 19.17

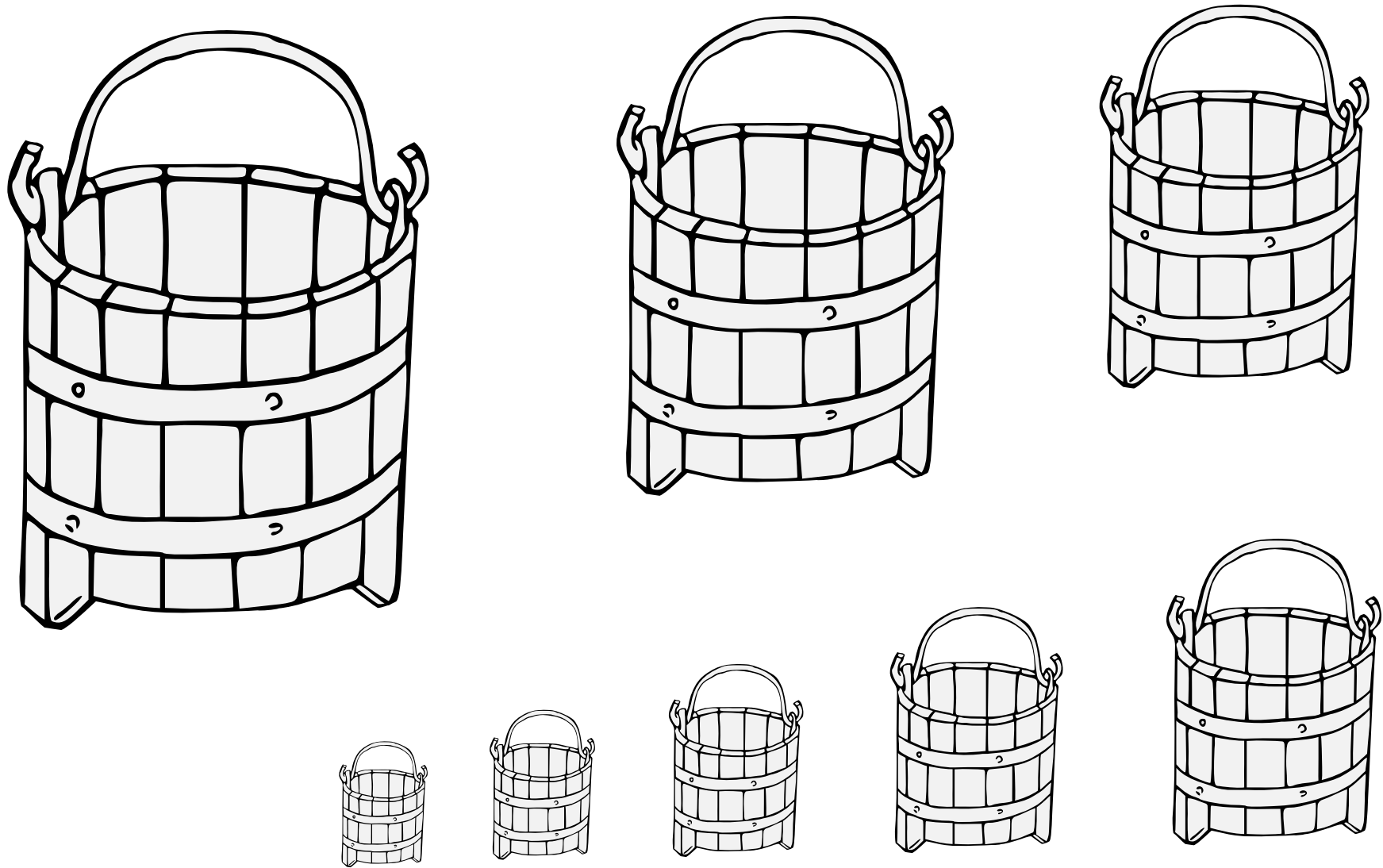

A container for carrying water, with a flat bottom and a curved handle.
Default orientation: handle to chief. Proper coloration: brown wood.
Artist: Vémundr Syvursson.

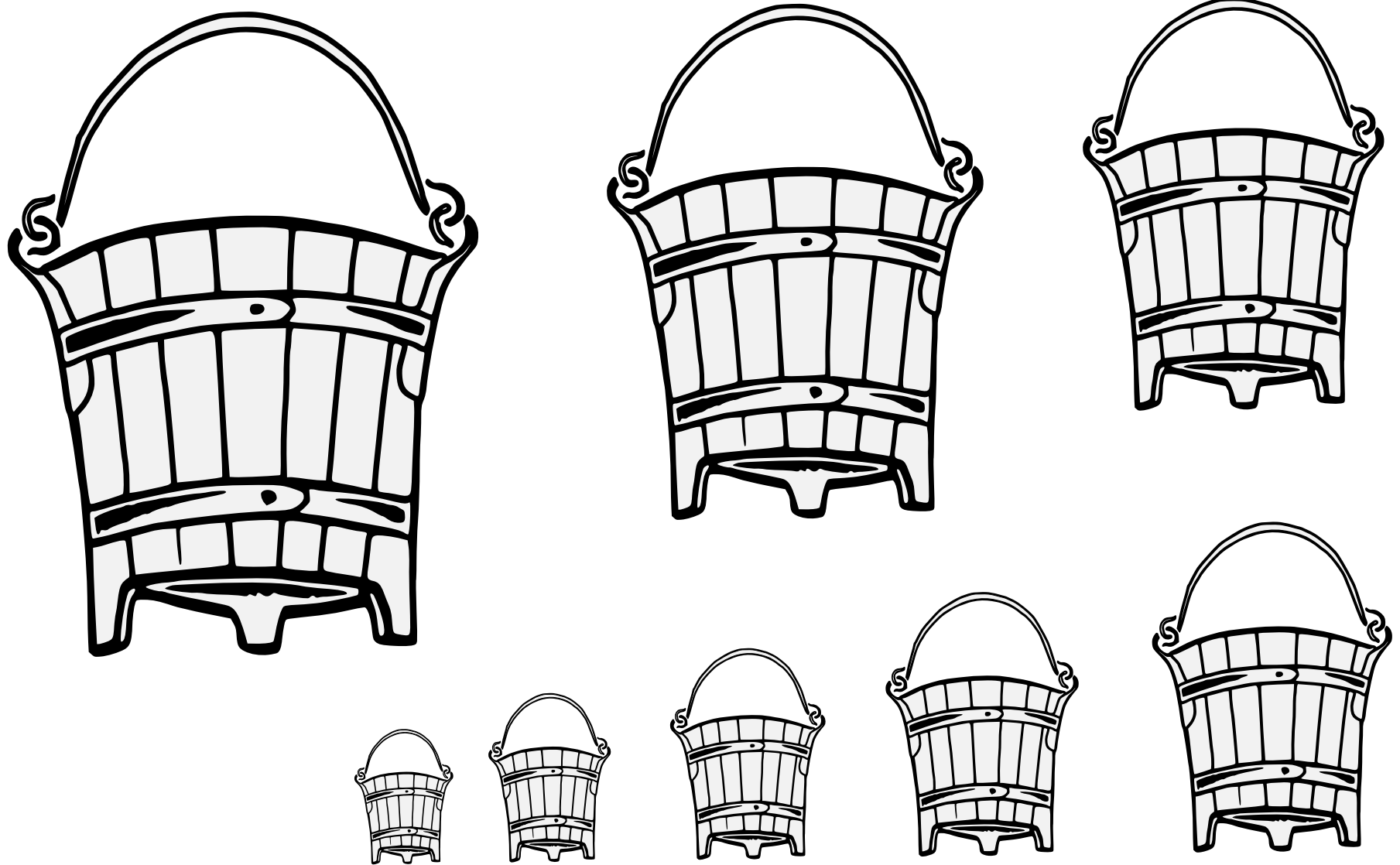

A container for carrying water, with a flat bottom and a curved handle.

Default orientation: handle to chief. Proper coloration: brown wood.

Source: Some Feudal Lords and Their Seals. Artist unknown.

Bucket (4) 19.19

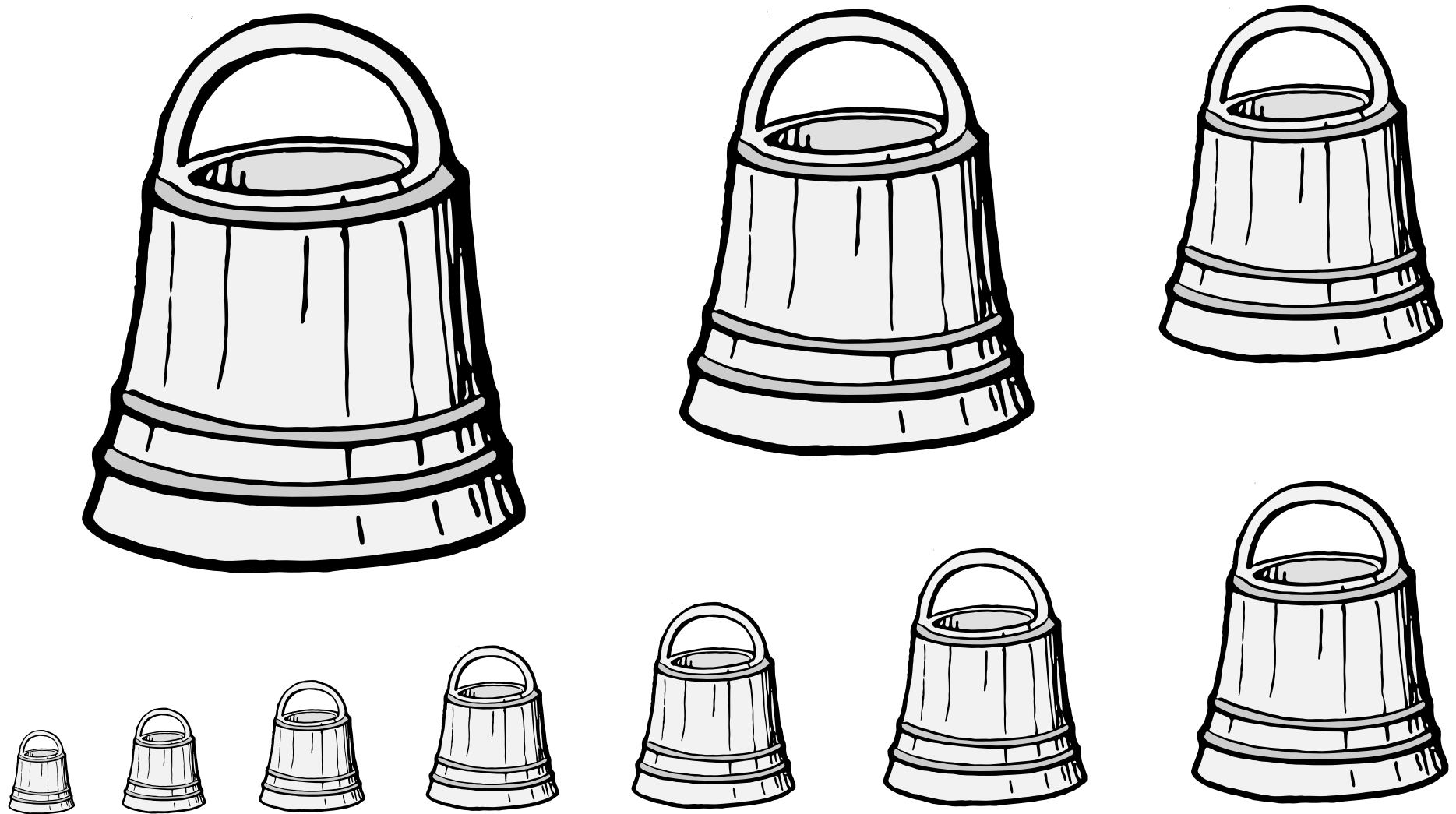

A container for carrying water, with a flat bottom and a curved handle.

Default orientation: handle to chief. Proper coloration: brown wood.

Source: Die Wappenbücher vom Arlberg. Artist: Otto Hupp. (Page 25.)

Bucket (5) 19.20

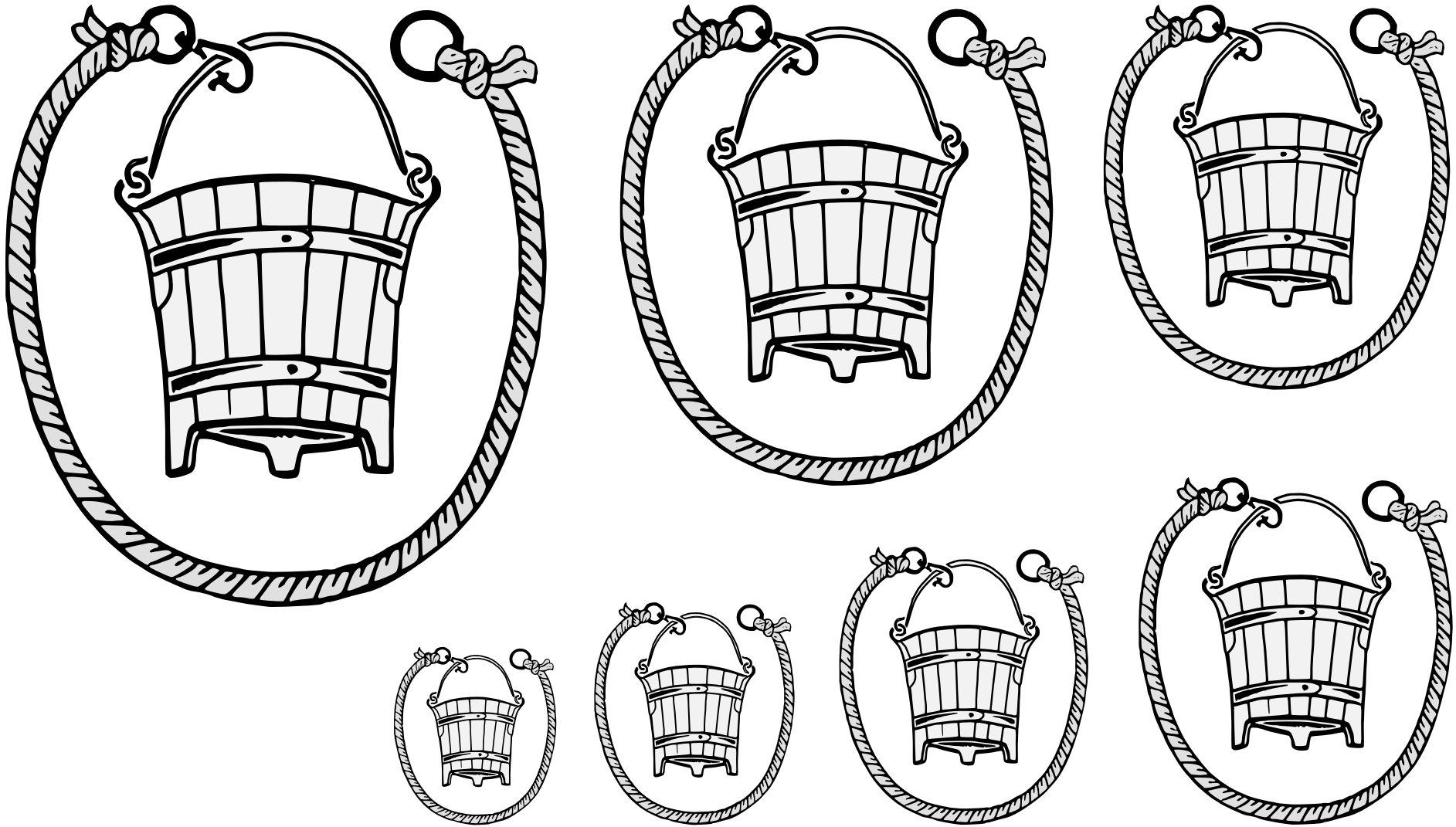

A container for carrying water, with a flat bottom and a curved handle.

Default orientation: handle to chief. Proper coloration: brown wood.

Source: Some Feudal Lords and Their Seals. Artist unknown.

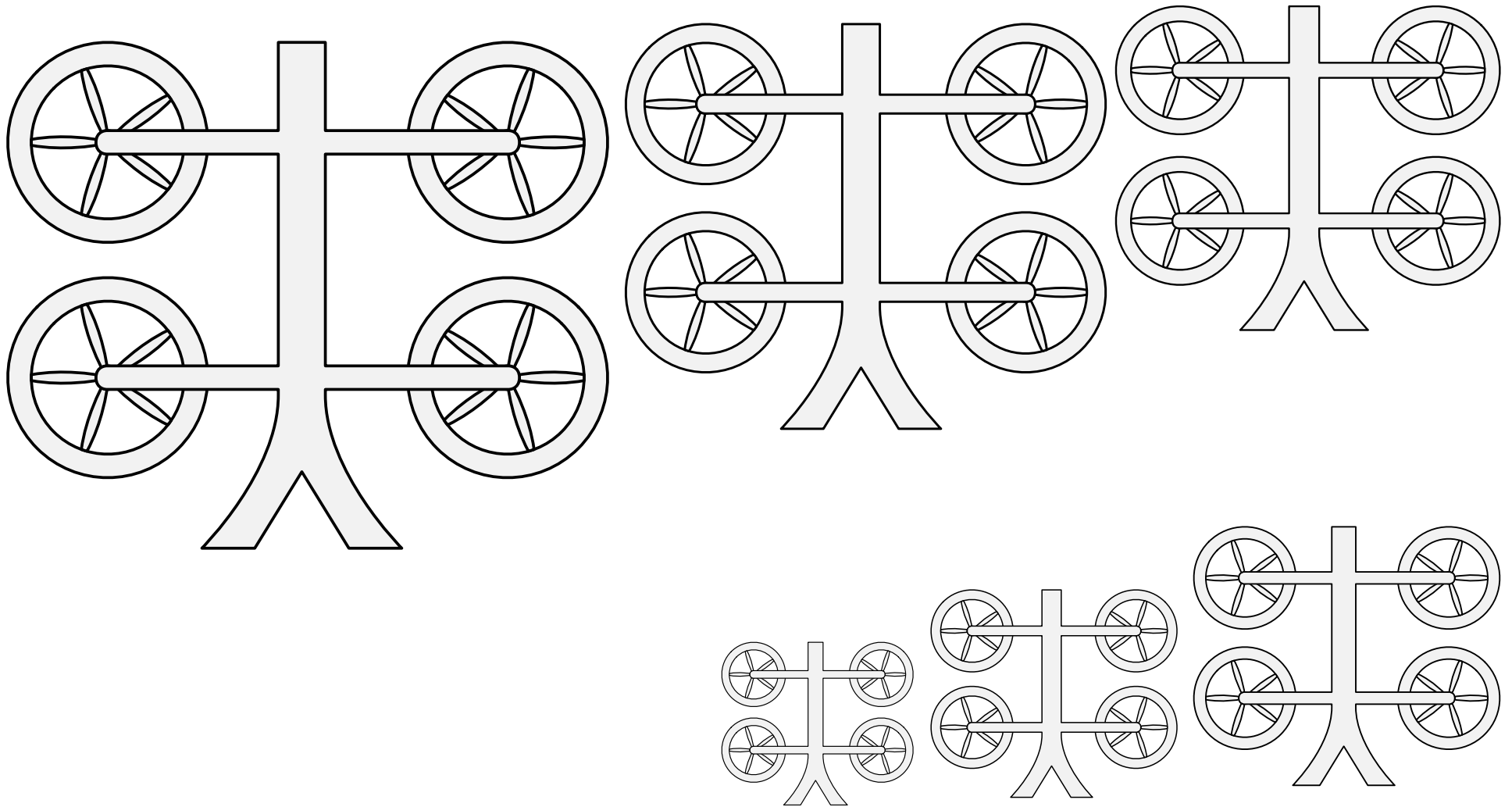

The wheels and connecting framework from the underside of a horse-drawn carriage

Default orientation: chassis palewise. No proper coloration.

Source: Wappenbuch Conrads von Grünenberg. Artist unknown.
(Page 23, arms of Carrara.)

Carriage Frame (1) 19.22

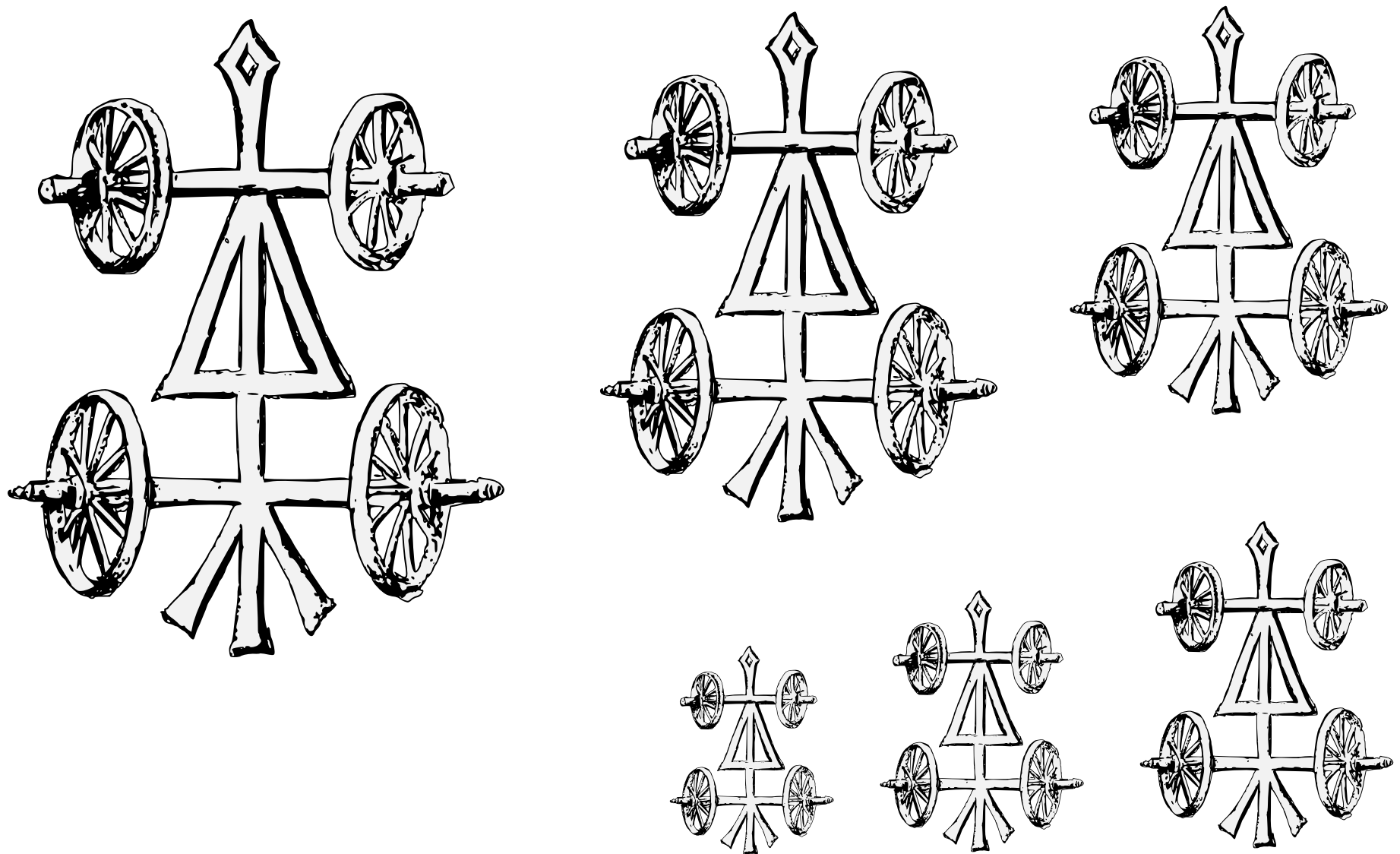

The wheels and underbody of a passenger cart.

Default orientation: tergiant, axles fesswise. Proper coloration: brown wood.

Source: Rylands MS 2. Artist unknown. (Page 33.)

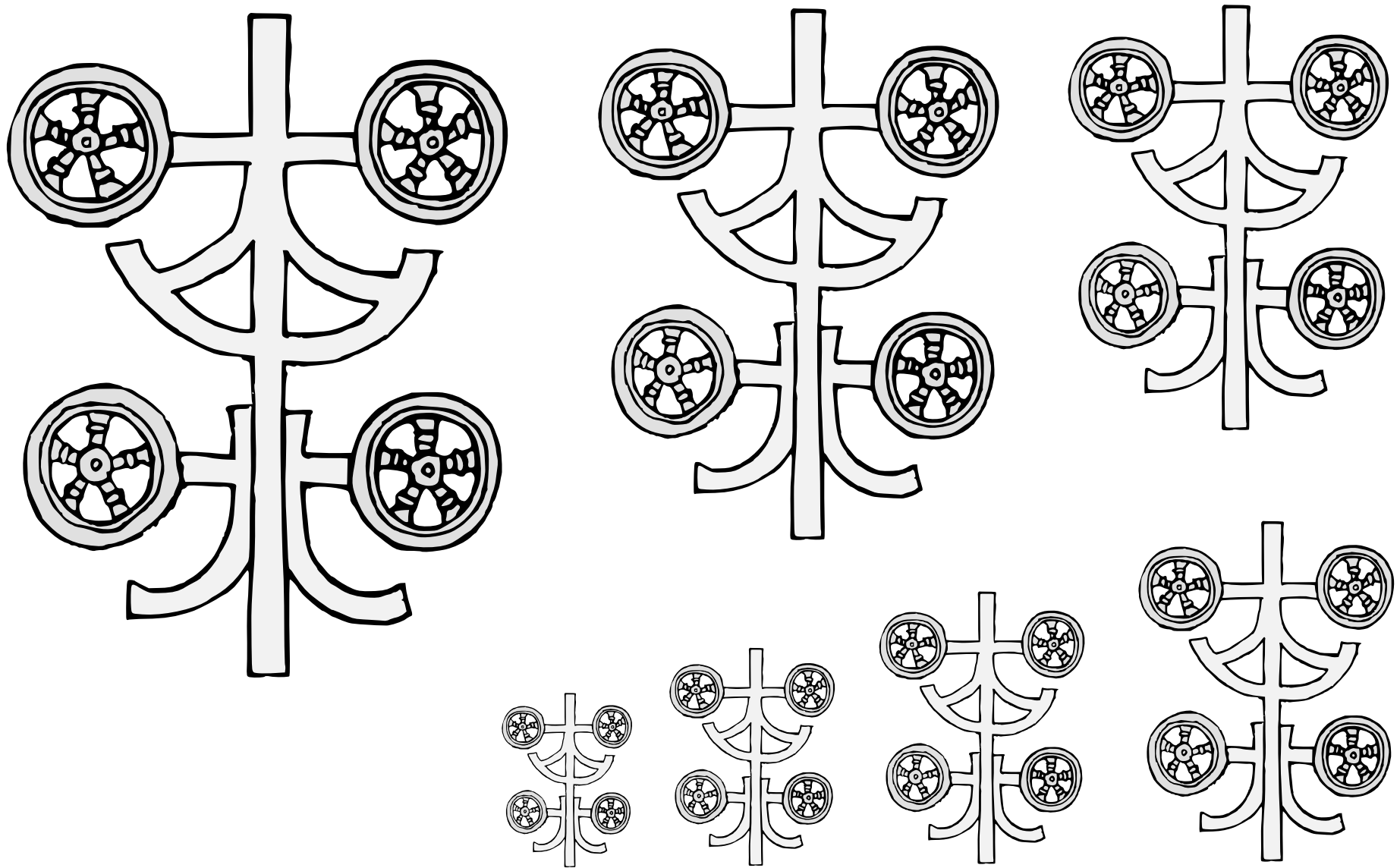

The wheels and connecting framework from the underside of a horse-drawn carriage.

Default orientation: chassis palewise, axles fesswise. Proper coloration: brown wood.

Source: Stemmario Trivulziano. Artist: Gian Antonio da Tradate.
(Page 87, arms of de Carara.)

Carriage Frame (3) 19.24

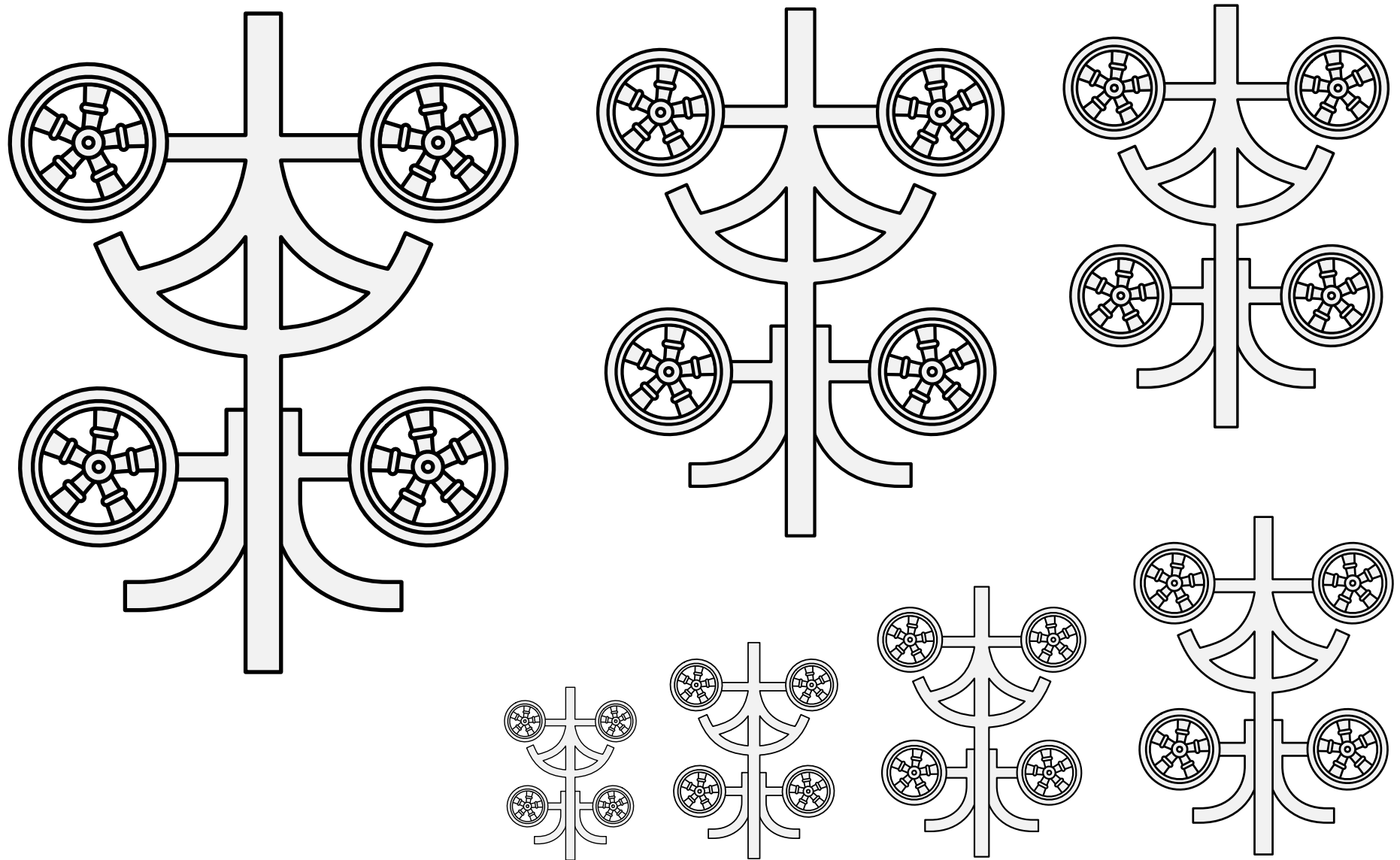

The wheels and connecting framework from the underside of a horse-drawn carriage.

Default orientation: chassis palewise, axles fesswise. Proper coloration: brown wood.

Source: Stemmario Trivulziano. Artist: Gian Antonio da Tradate.
(Page 87, arms of de Carara.) Adapted by Mathghamhain Ua Ruadháin.

Carriage Frame (4) 19.25

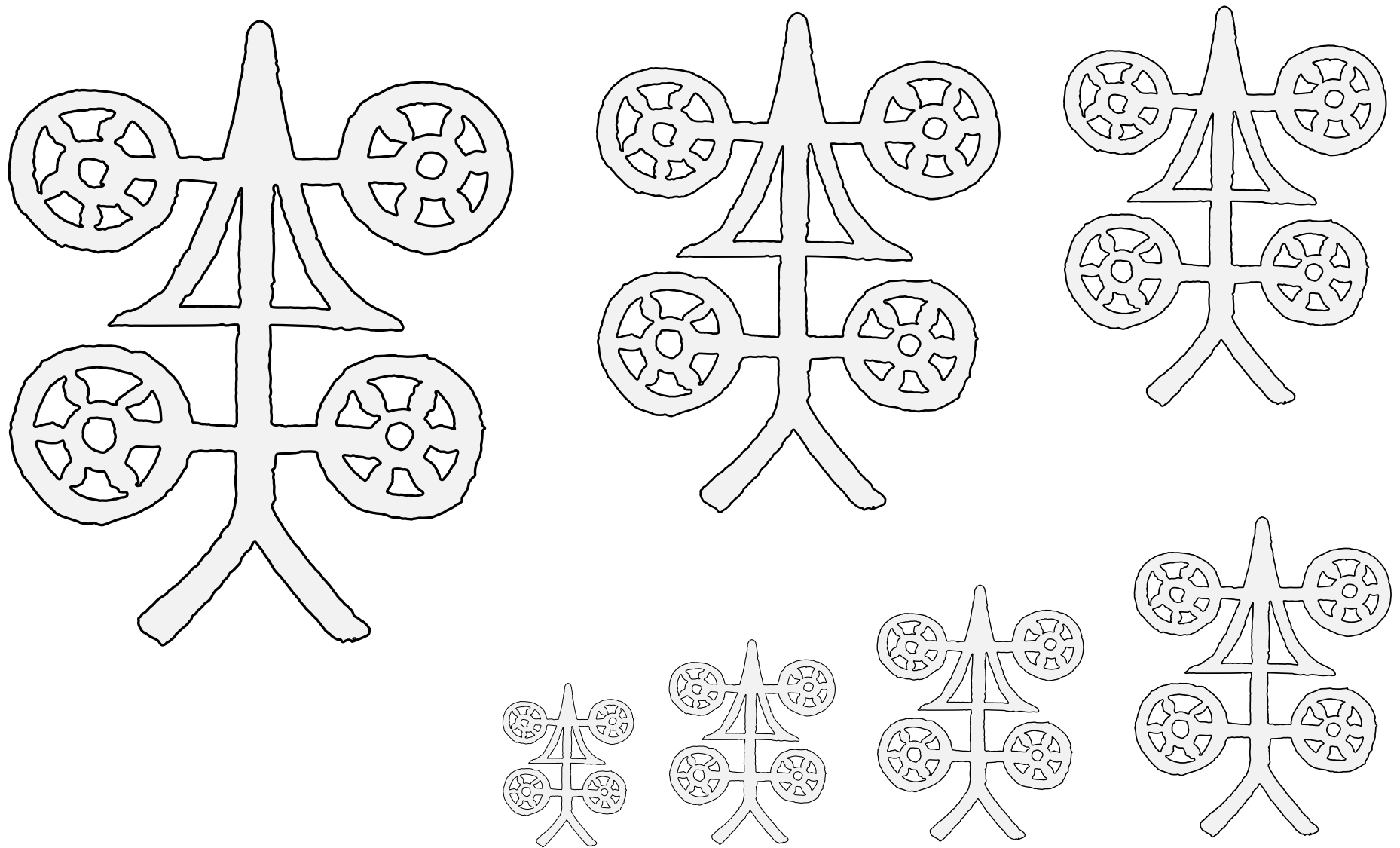

The wheels and connecting framework from the underside of a horse-drawn carriage.

Default orientation: chassis palewise. No proper coloration.

Source: Lambeth MS774. Artist unknown. (Folio 52v.)

Carriage Frame (5) 19.26

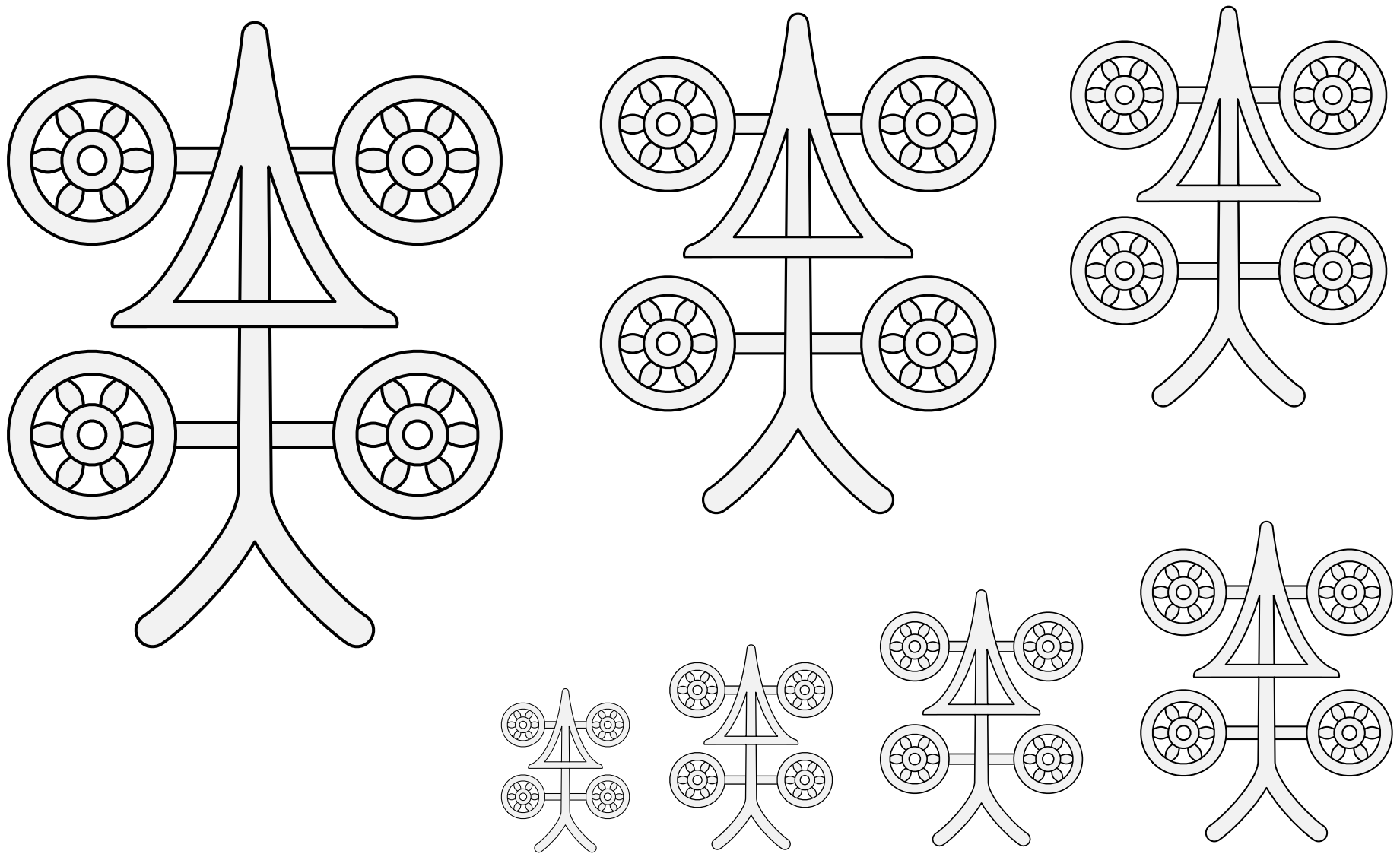

The wheels and connecting framework from the underside of a horse-drawn carriage.

Default orientation: chassis palewise. No proper coloration.

Source: Lambeth MS774. Artist unknown. (Folio 52v.)

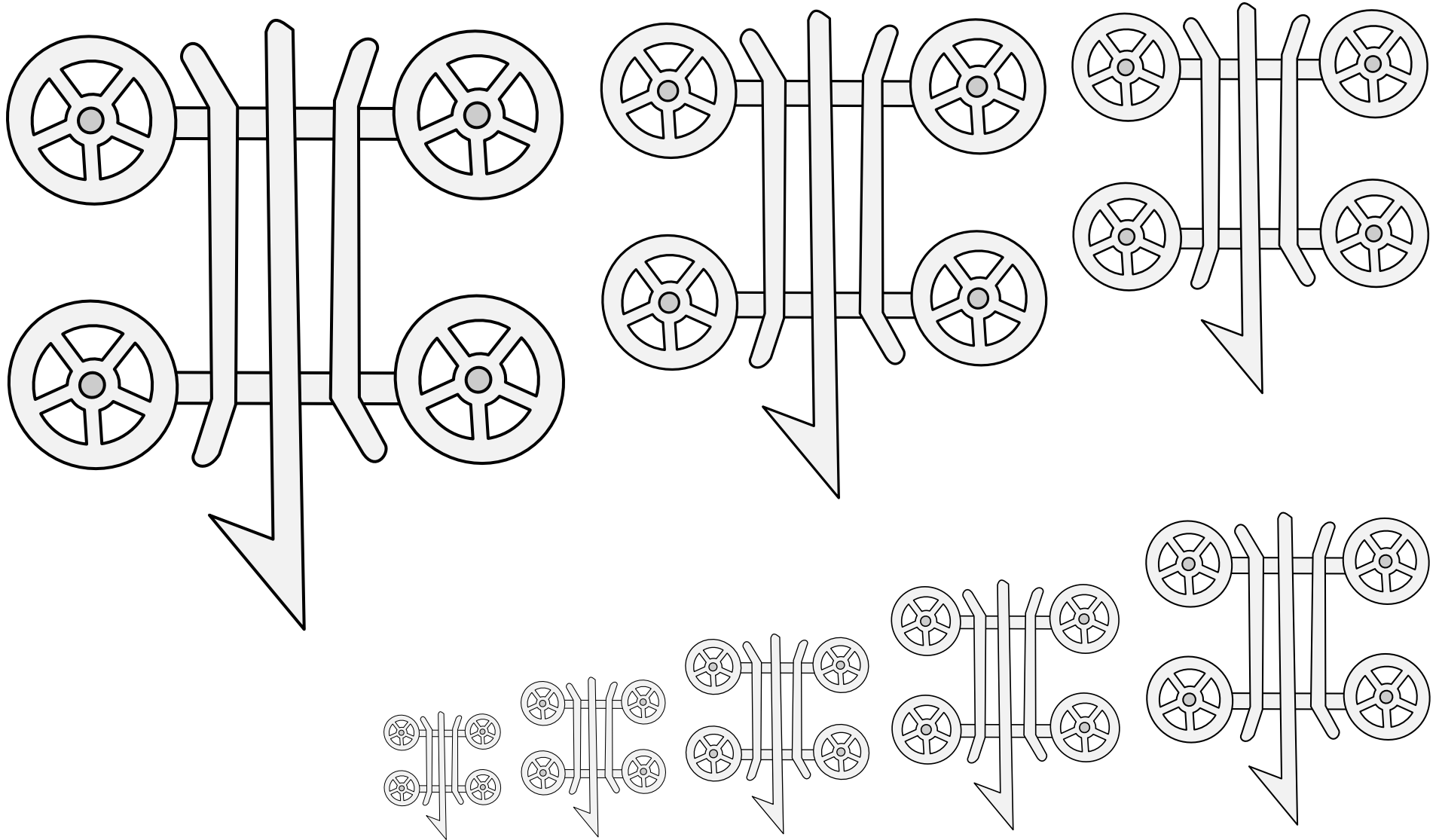

The wheels and connecting framework from the underside of a horse-drawn carriage.

Default orientation: chassis palewise. No proper coloration.

Source: Wikimedia Commons. Artist: Arch from Wikimedia.

Adapted from Gorrevod Armorial.

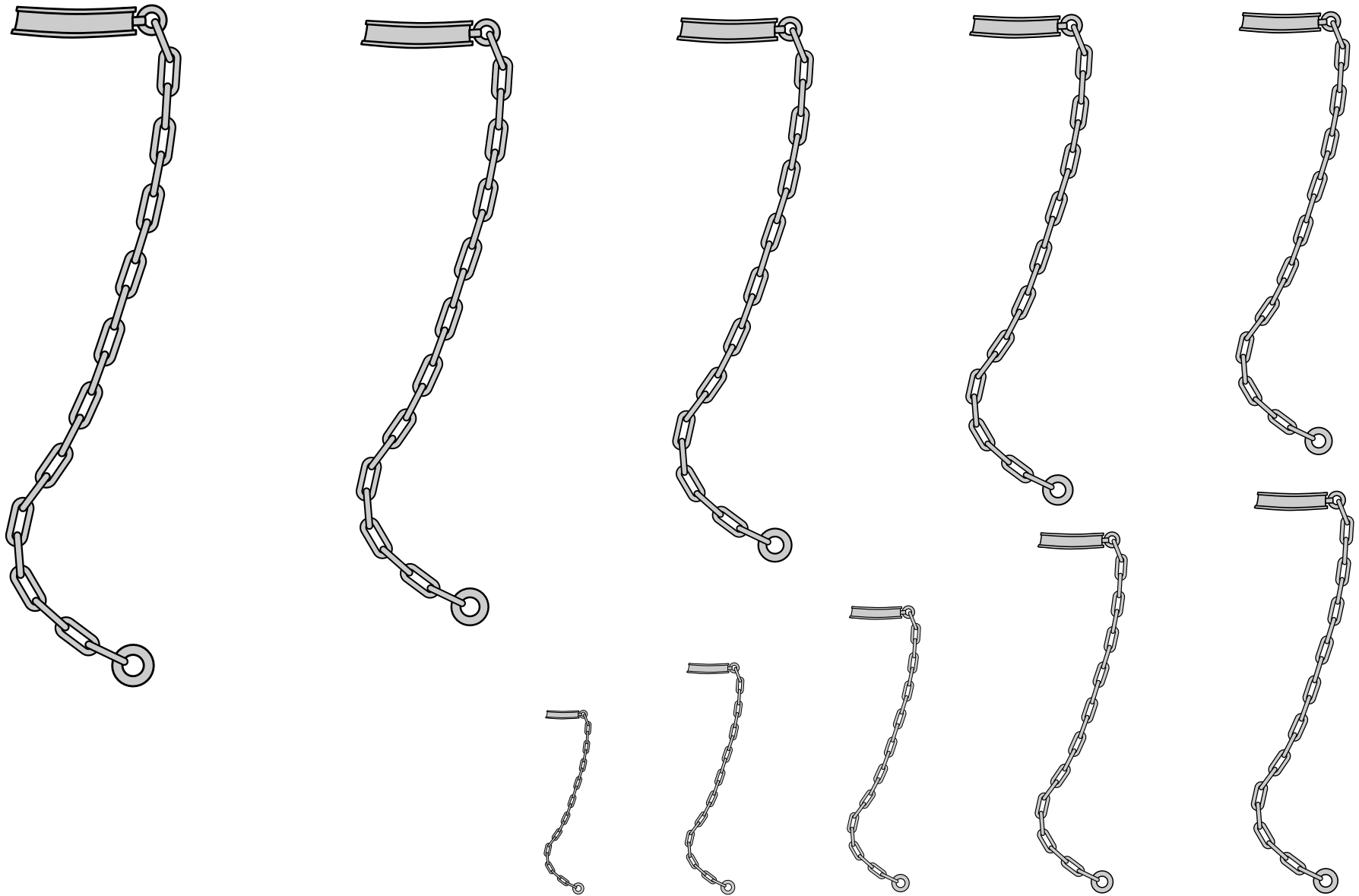

A flexible form of confinement for wild animals.

No default orientation. No proper coloration.

Source: WappenWiki. Artist: Joakim Spuller. Adapted by Finellach.

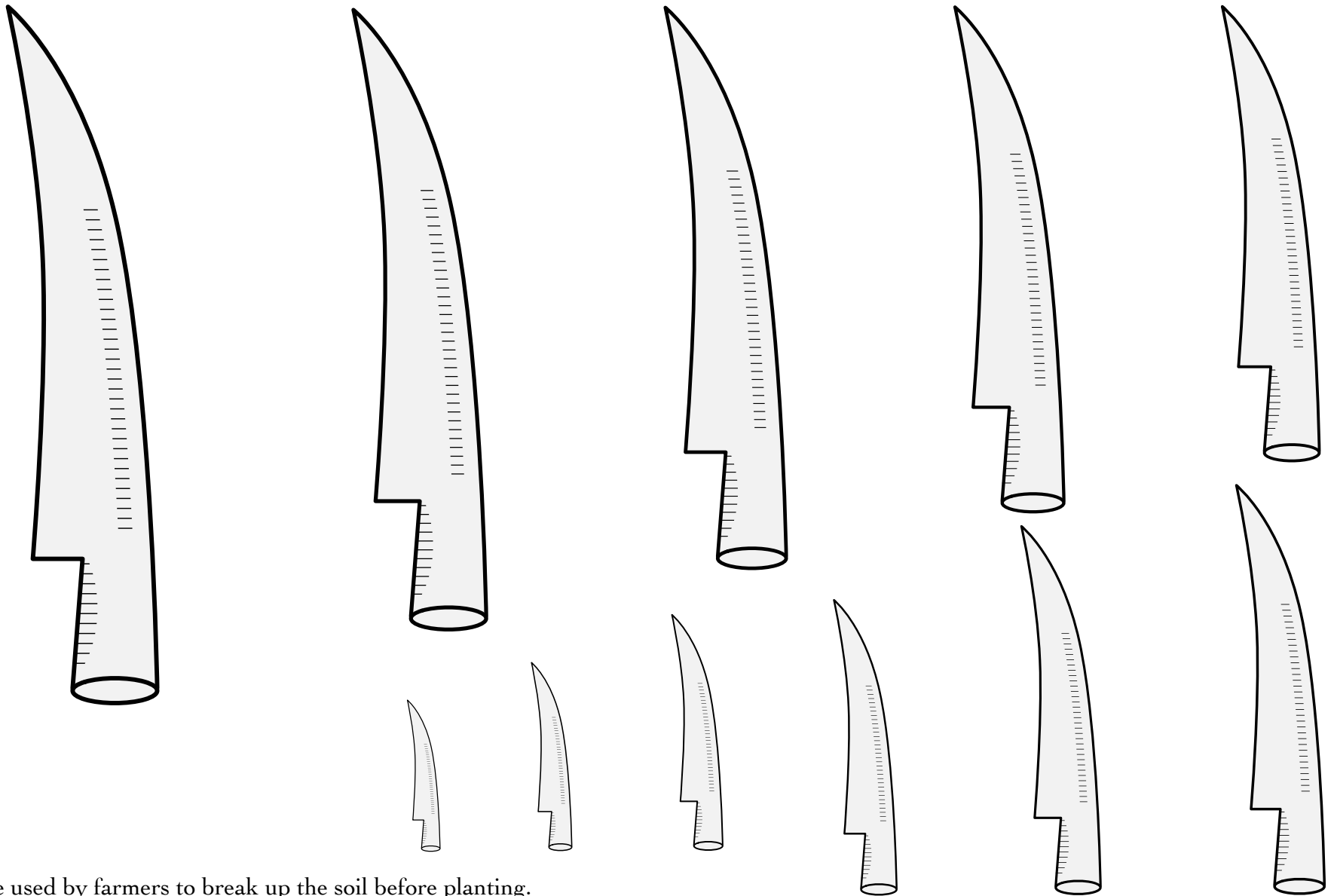

A blade used by farmers to break up the soil before planting.
The coultre makes an initial cut in the soil, which is then turned over by the ploughshare.

Default orientation: point to chief, cutting to dexter. No proper coloration.

Source: Siebmacher's Wappenbuch of 1605. Artist: Johann Siebmacher.
(Arms of Bissing, folio 163.) Adapted by Mathghamhain Ua Ruadháin.

Coultre (1) 19.30

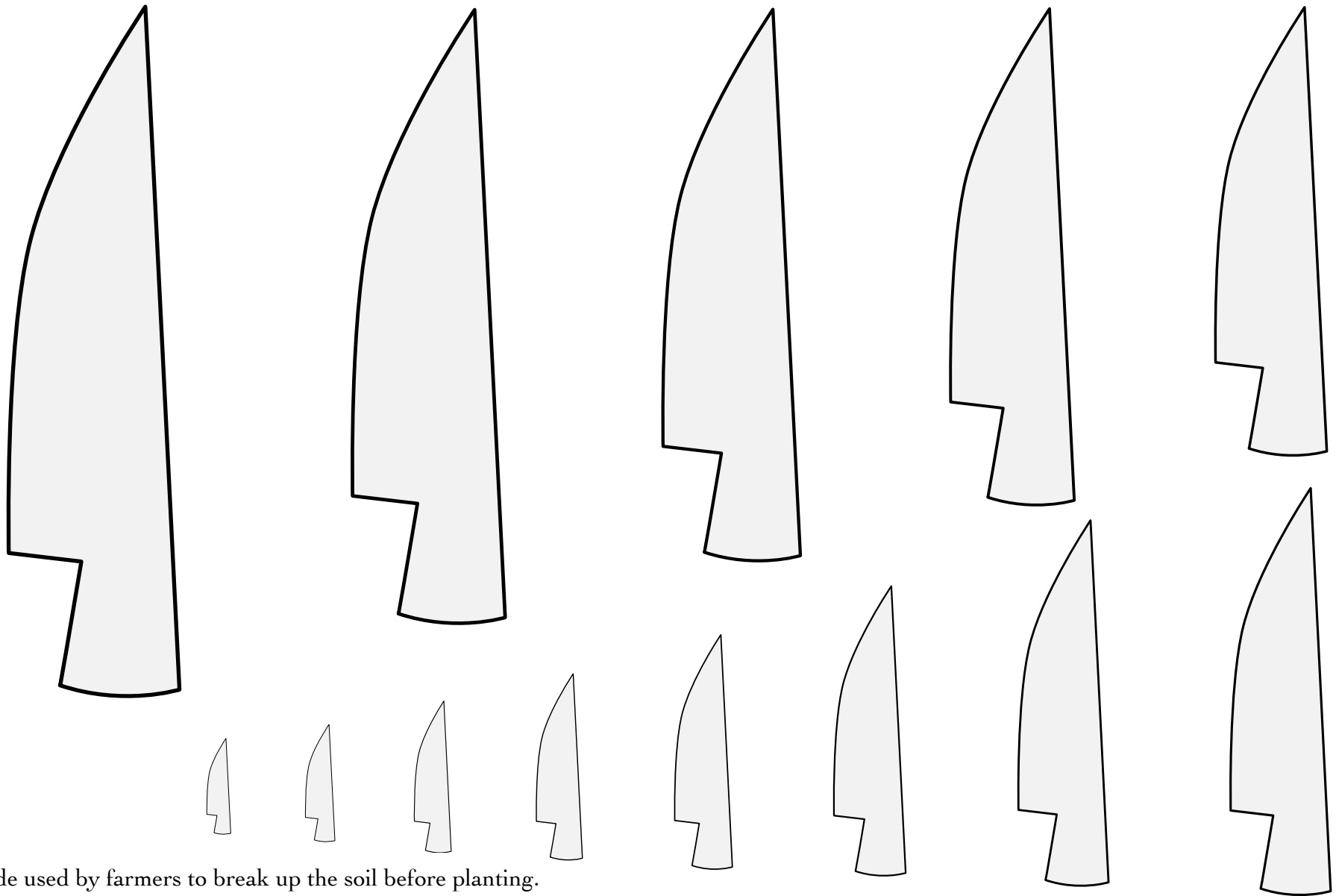

A blade used by farmers to break up the soil before planting.
The coultre makes an initial cut in the soil, which is then turned over by the ploughshare.

Default orientation: point to chief, cutting to dexter. No proper coloration.

Source: Siebmacher's Wappenbuch of 1605.

Artist: Johann Siebmacher. (Arms of Köhler, folio 169.)

Coultre (2) 19.31

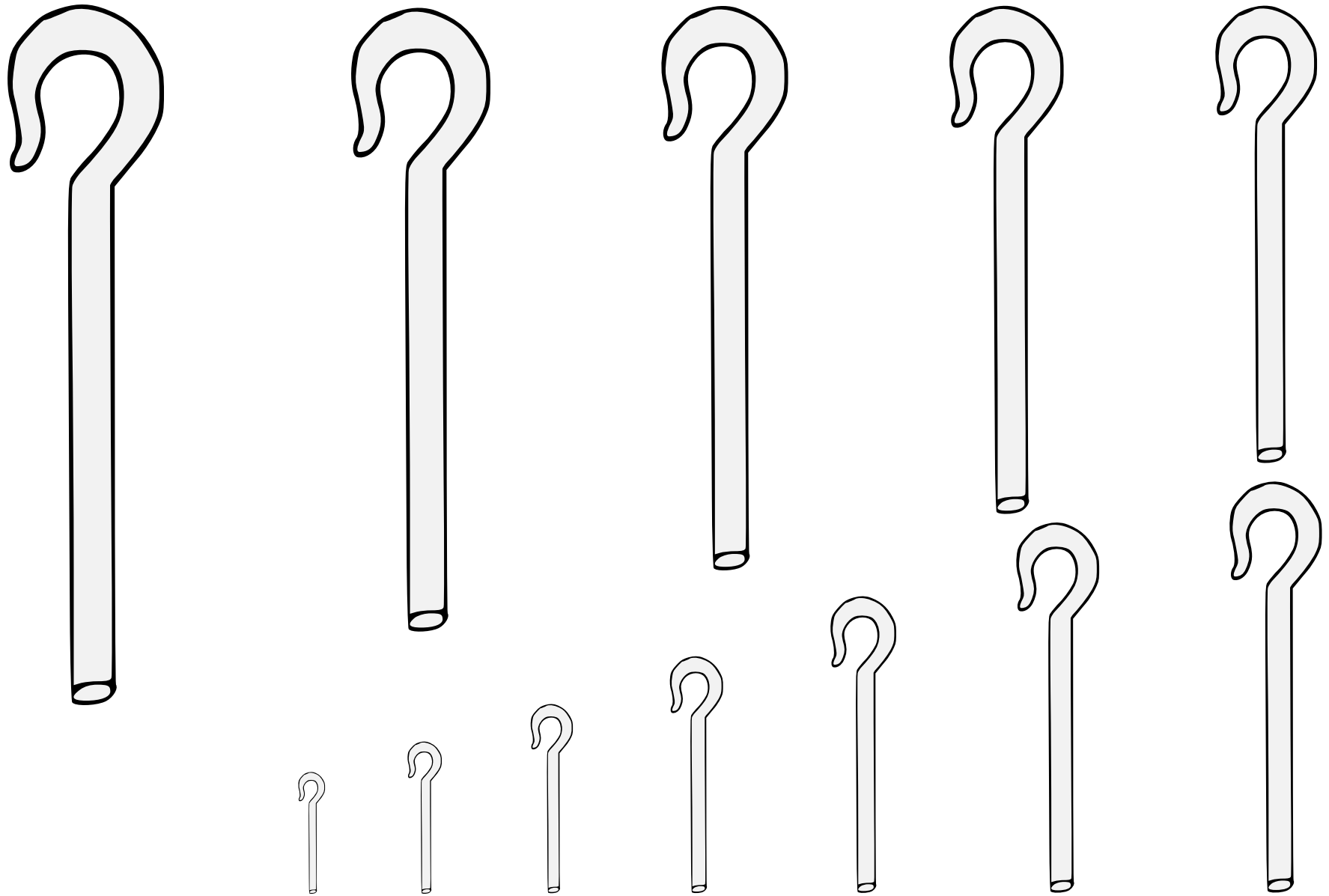

A staff with a bent end.

Default orientation: palewise, handle to dexter chief. No proper coloration.

Source: Pennsic Traceable Art. Artist unknown.

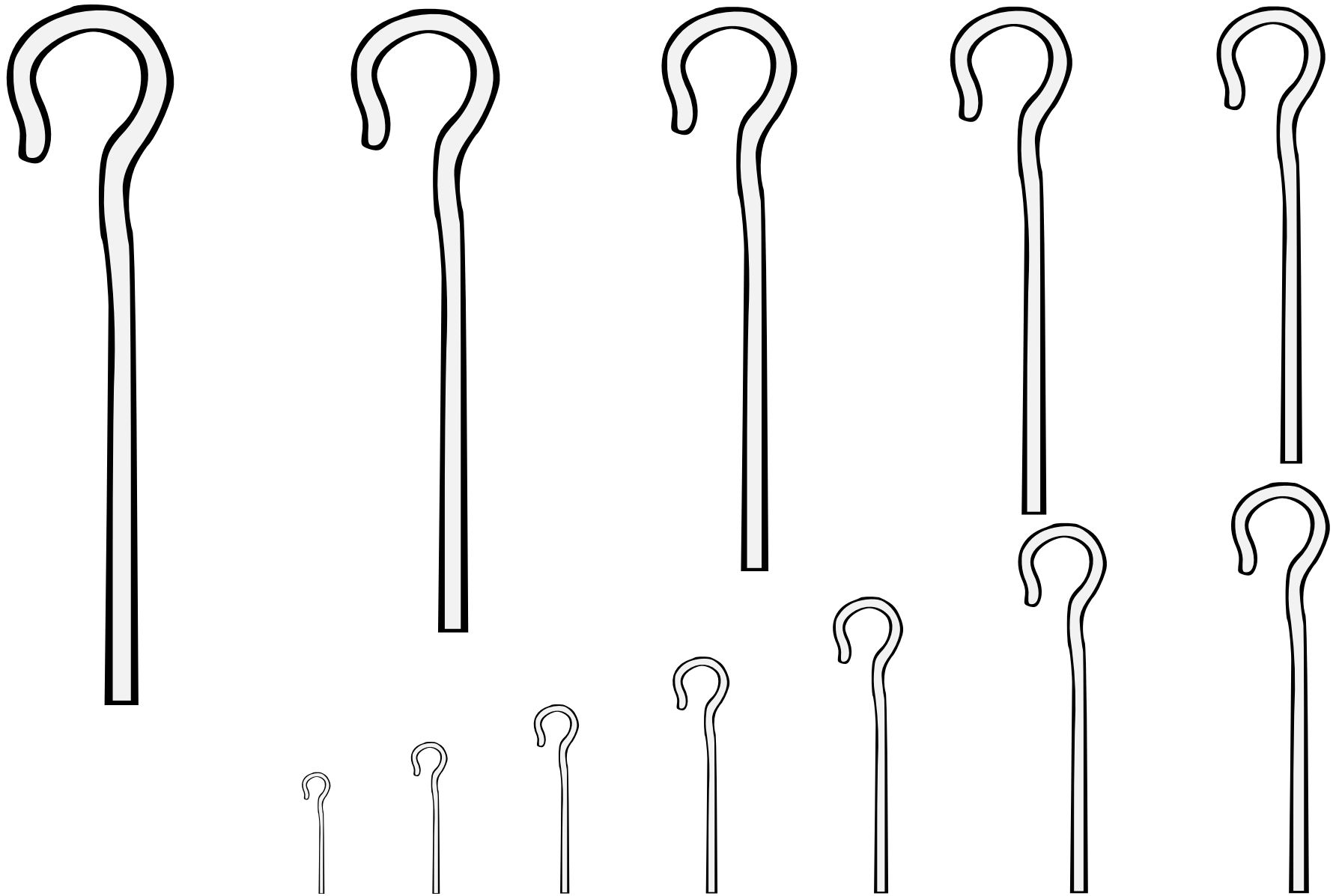

A staff with a bent end.

Default orientation: palewise, handle to dexter chief. No proper coloration.

Source: Pennsic Traceable Art. Artist unknown.

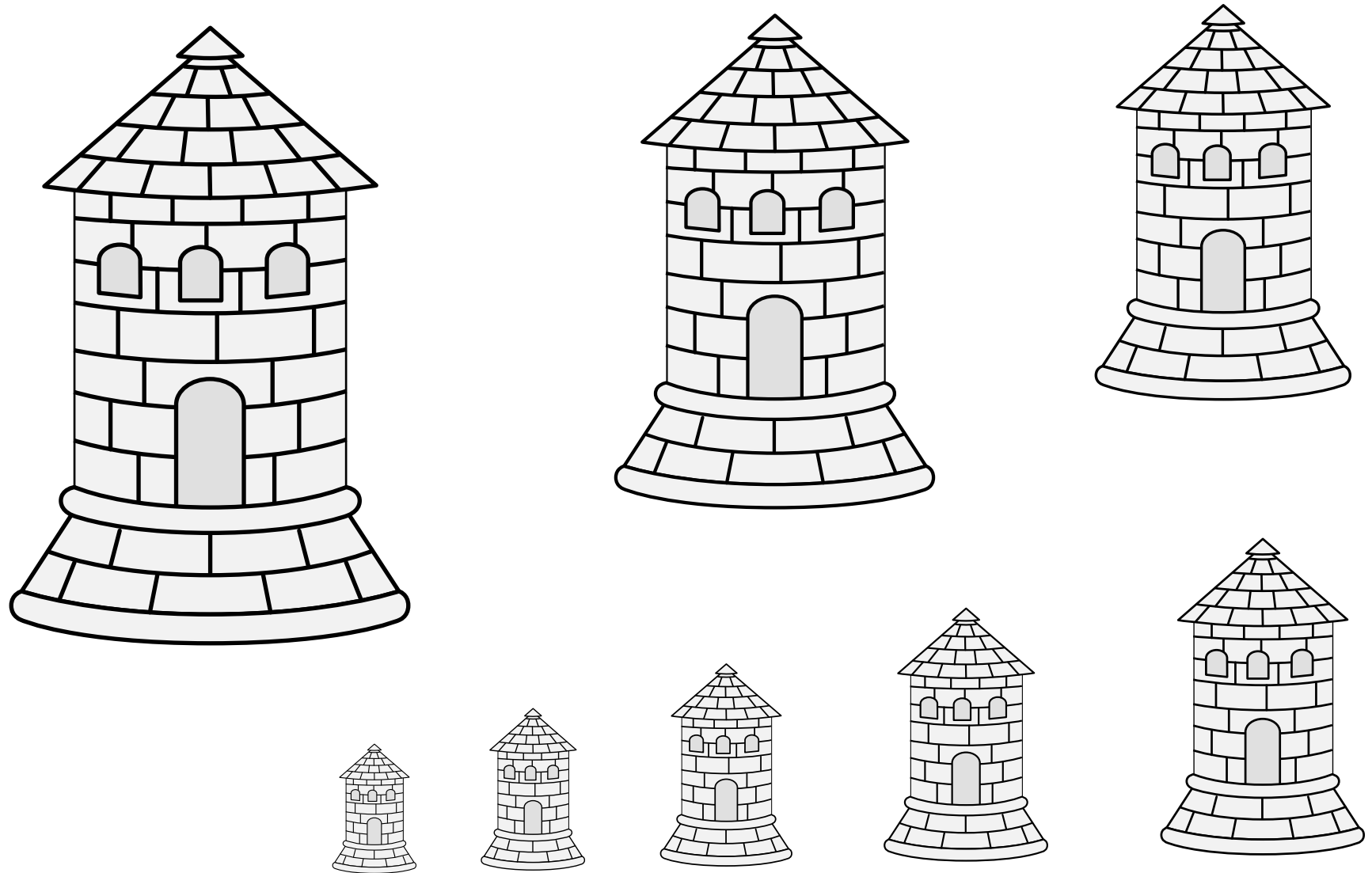

A small building designed as a home for domesticated pigeons. Typically drawn as a stone tower.

Default orientation: upright. No proper coloration.

Adapted from a depiction of the arms of Sapcote in a stained-glass panel in Bampton Church, Devon.

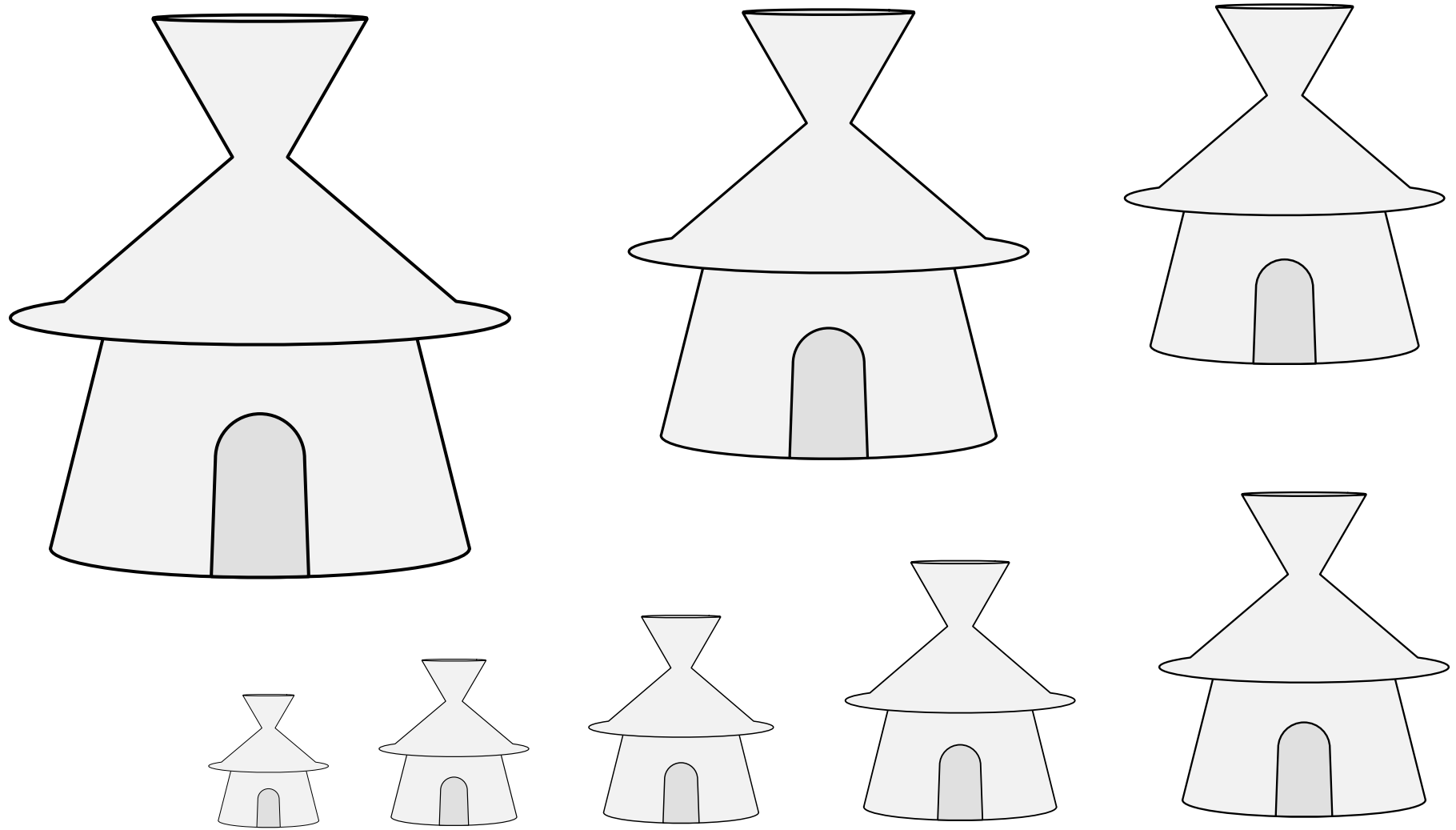

A small building designed as a home for domesticated pigeons. Typically drawn as a stone tower.

Default orientation: upright. No proper coloration.

Source: Recueil de Généalogies Anglaises, Accompagnées d'Armoiries. Artist unknown.

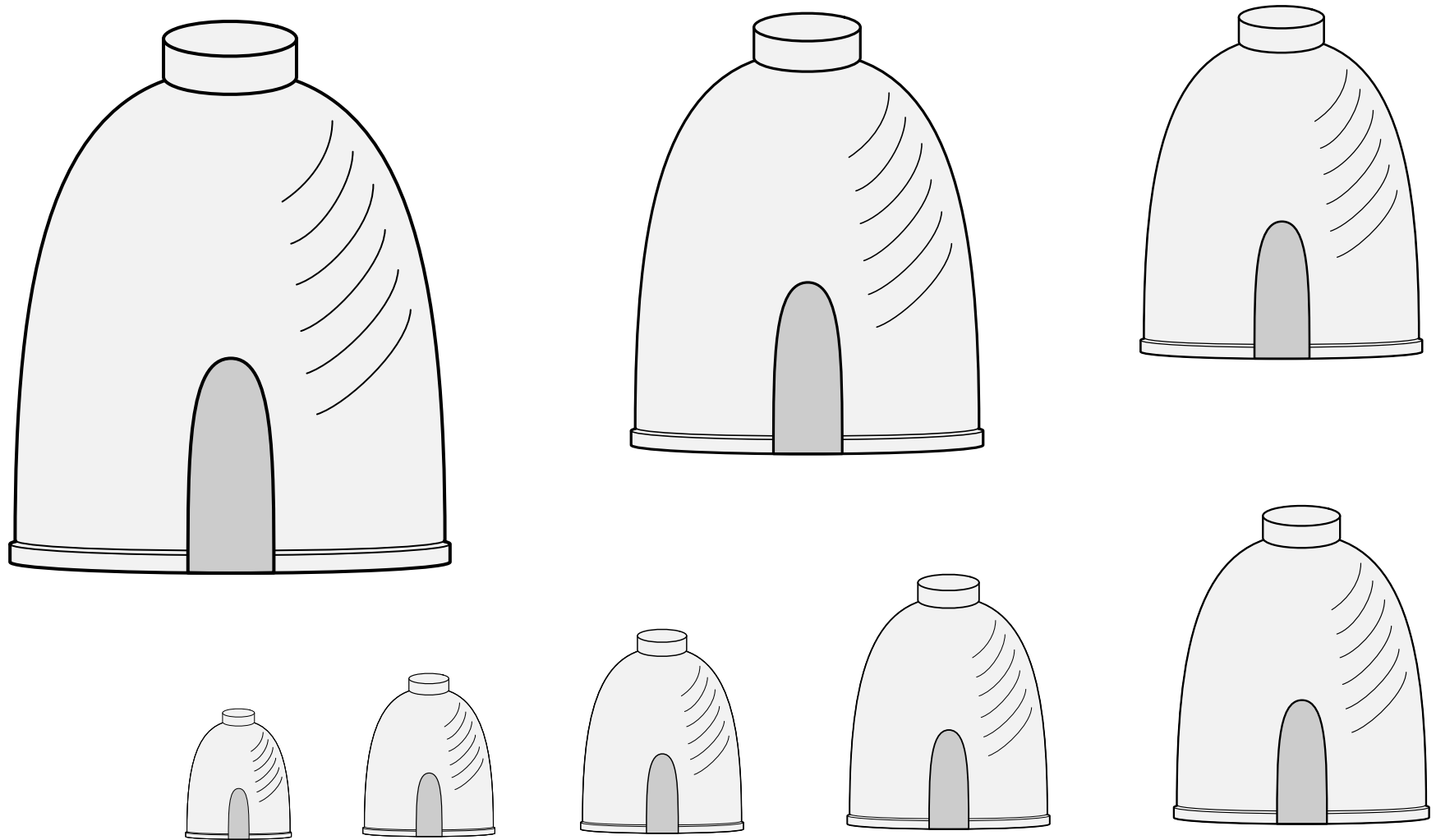

A small building designed as a home for domesticated pigeons. Typically drawn as a stone tower.

Default orientation: upright. No proper coloration.

Source: Insignia Anglica. Artist unknown. (Arms of Sapcotes.)

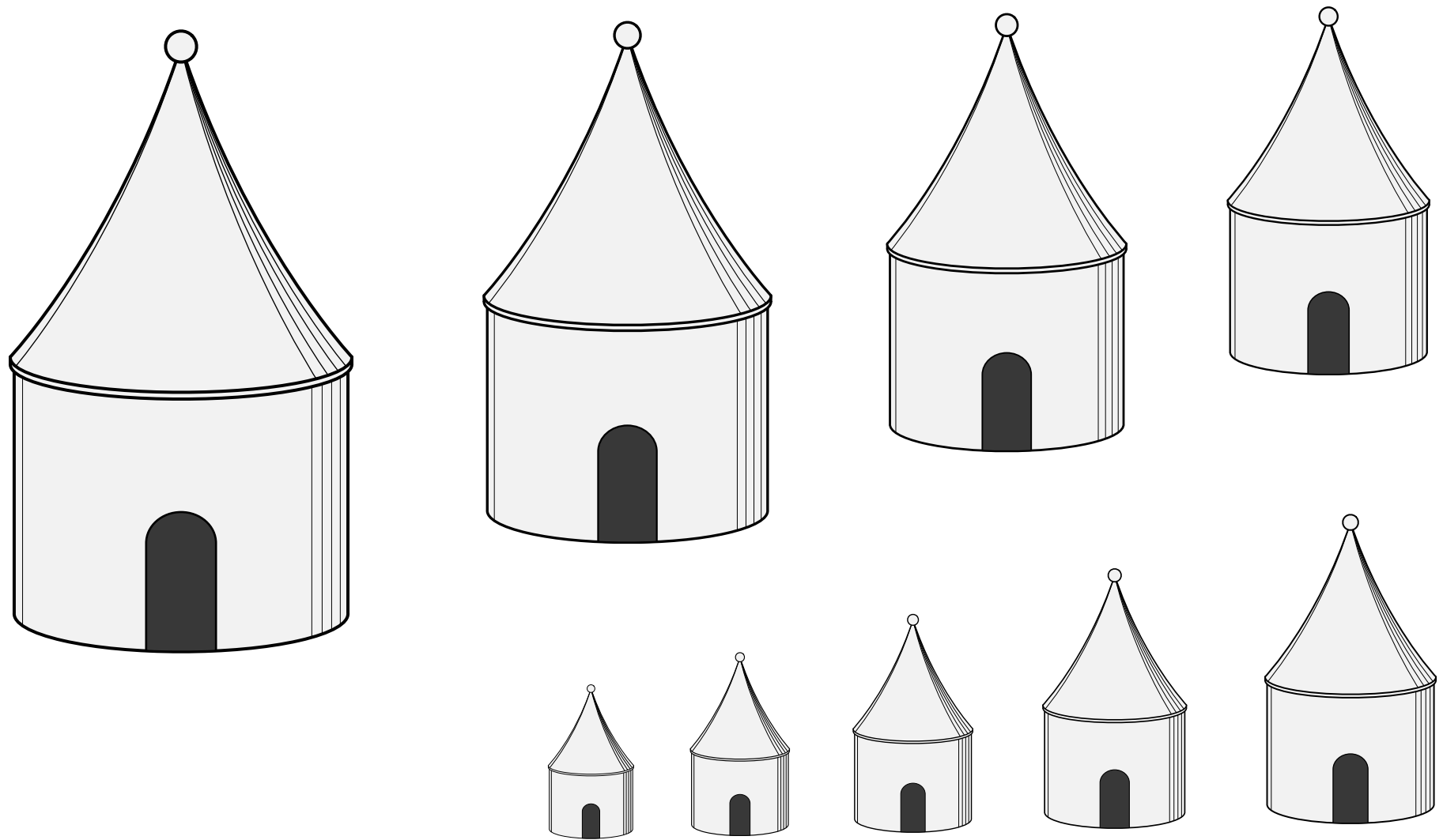

A small building designed as a home for domesticated pigeons. Typically drawn as a stone tower.

Default orientation: upright. No proper coloration.

Source: A Glossary of Terms Used in Heraldry. Artist: James or Irene Parker.

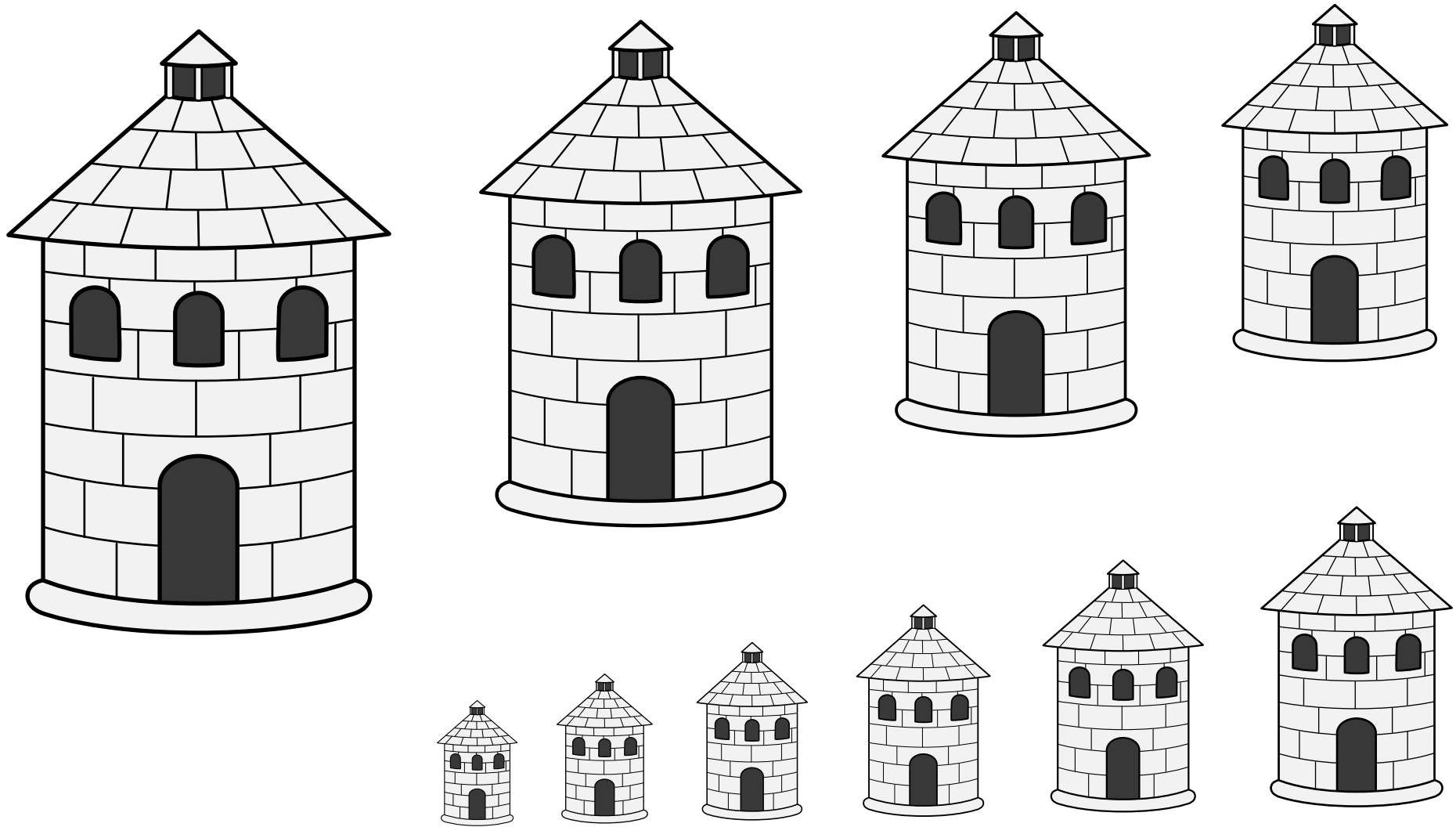

A small building designed as a home for domesticated pigeons. Typically drawn as a stone tower.
Default orientation: upright. No proper coloration.

Dovecote (5) 19.38

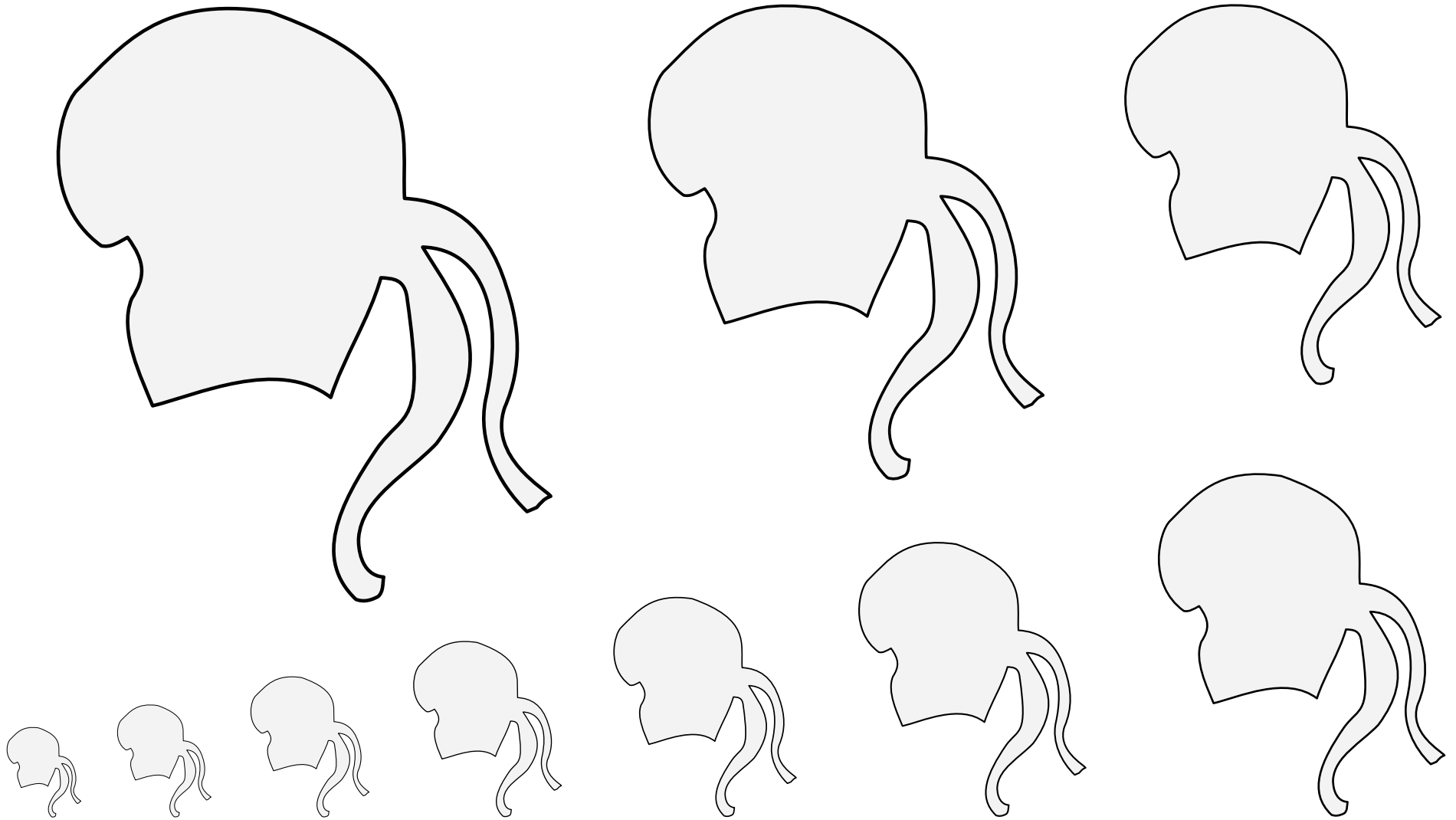

A small piece of fabric designed to cover the eyes of a domesticated hunting bird to keep it calm and quiet.

No default orientation. No proper coloration.

Source: BnF MS Fr 5240. Artist unknown. Adapted by Iago ab Adam.

Falcon's Hood 19.39

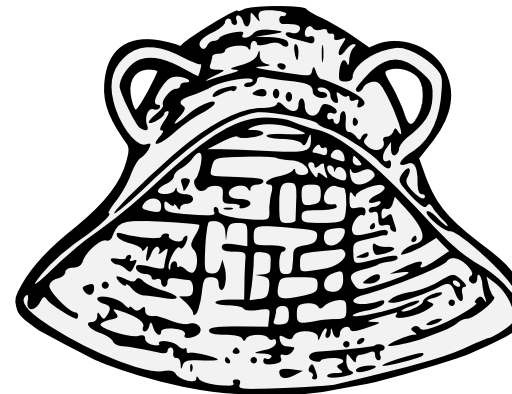
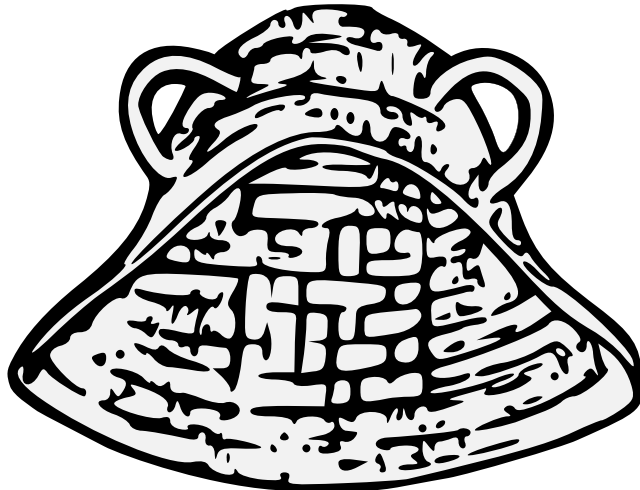
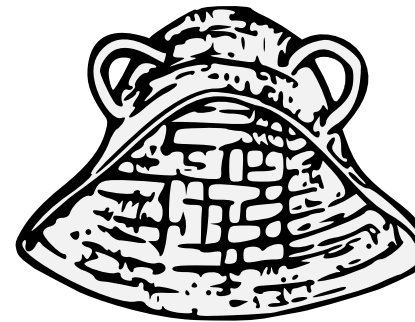
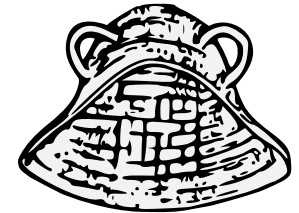
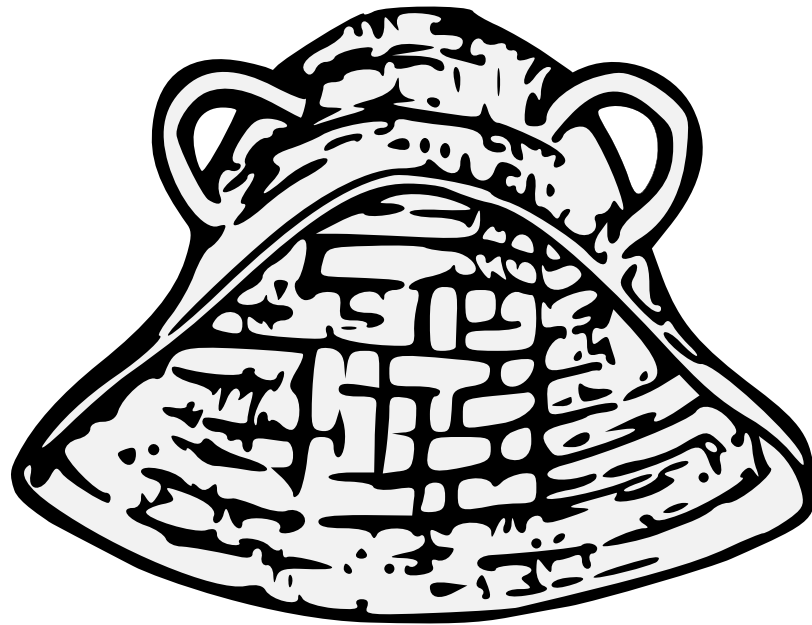

A hand-held breeze-maker used to separate grains of wheat from their accompanying chaff.

Default orientation: handle to chief. No proper coloration.

Adapted from the arms of de Septvans, as recorded in a 14th C. monumental brass in Chartham, Kent.

Fan, Winnowing (1) 19.40

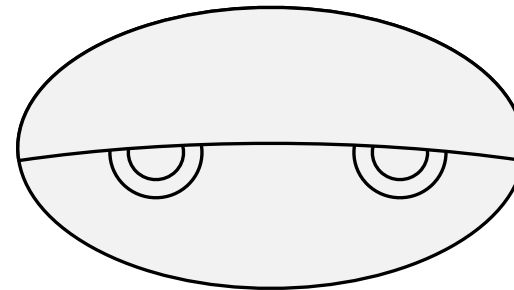
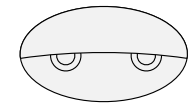
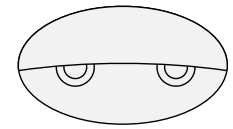
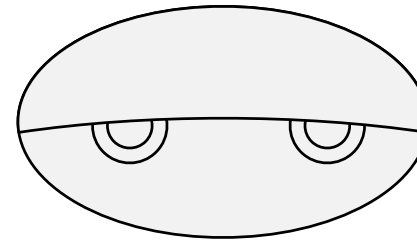
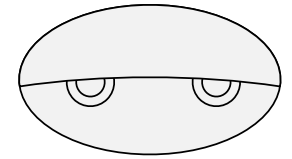
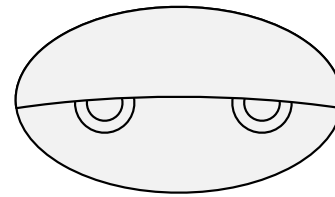
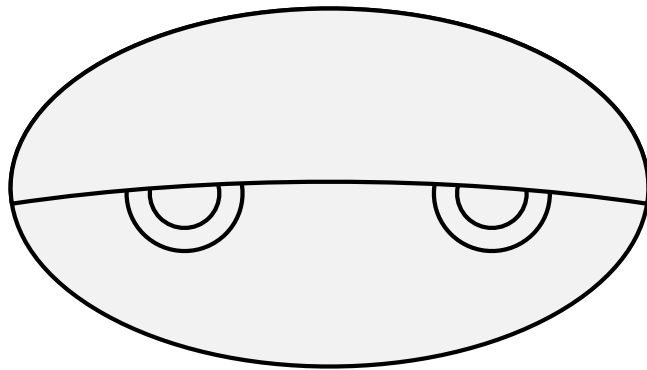
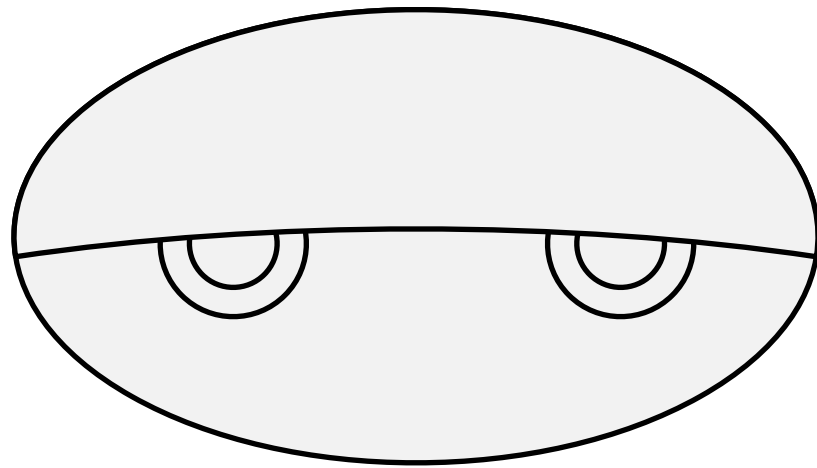

A hand-held breeze-maker used to separate grains of wheat from their accompanying chaff.

Default orientation: handle to chief. No proper coloration.

Source: English Arms A. Artist unknown. (Page 195.)

Fan, Winnowing (2) 19.41

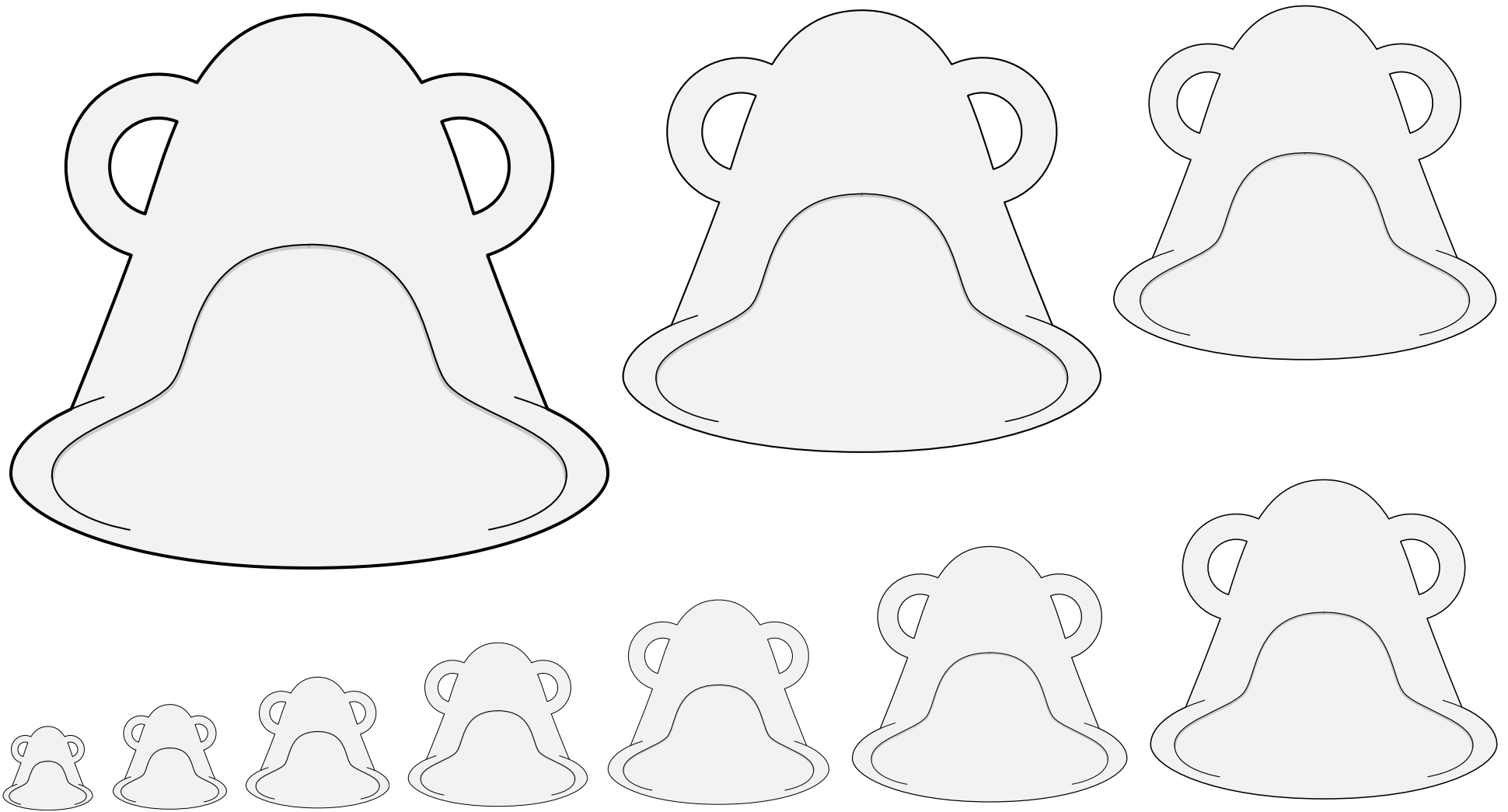

A hand-held breeze-maker used to separate grains of wheat from their accompanying chaff.

Default orientation: handle to chief. No proper coloration.

Fan, Winnowing (3) 19.42

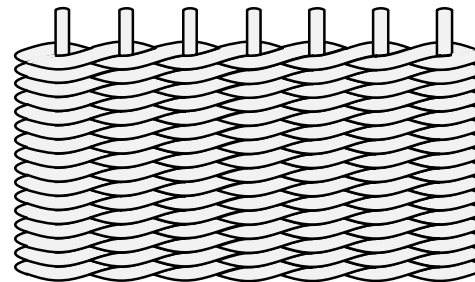
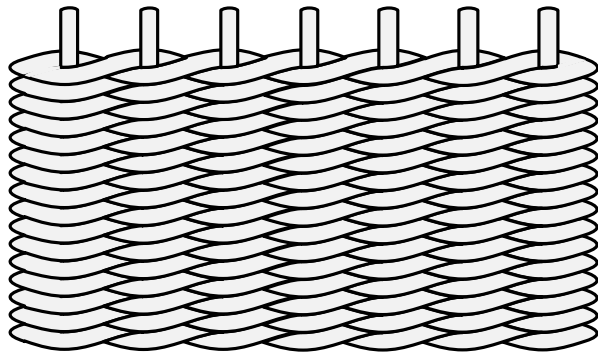
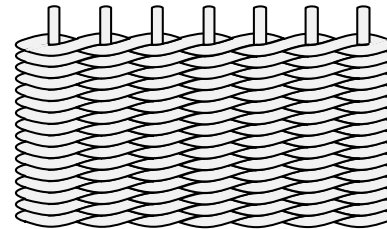
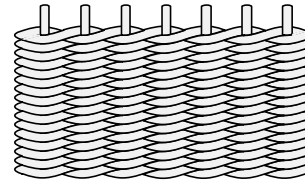
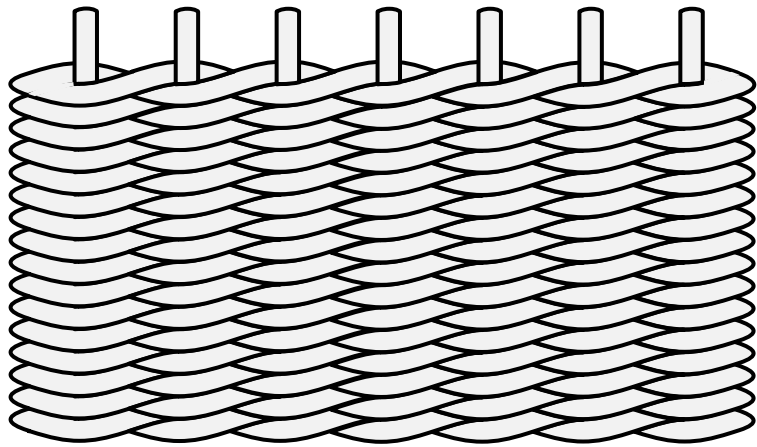

A barrier made of woven twigs. May also be blazoned a “weir.”

Default orientation: fesswise. No proper coloration.

Source: Scheibler Armorial. Artist unknown.

Adapted by Mathghamhain Ua Ruadháin.

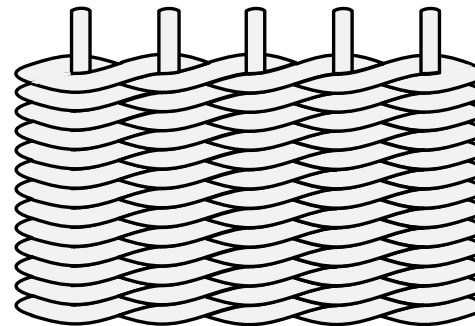
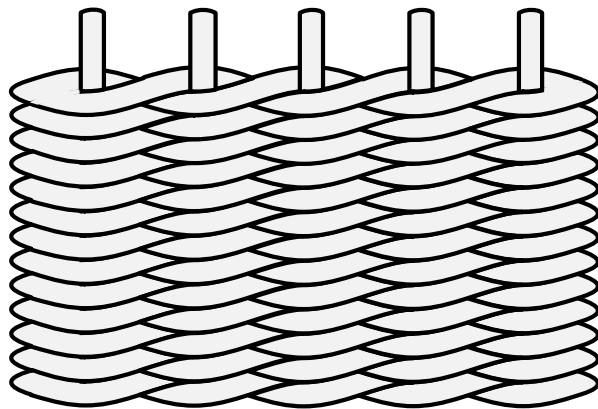
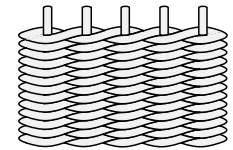
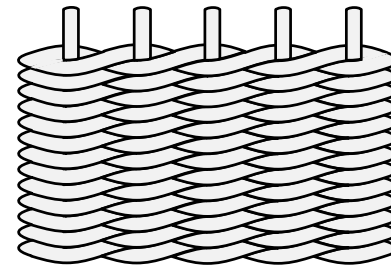
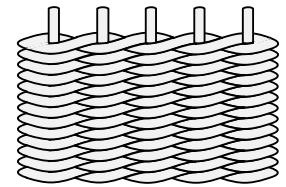
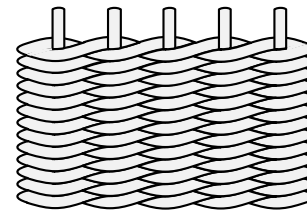
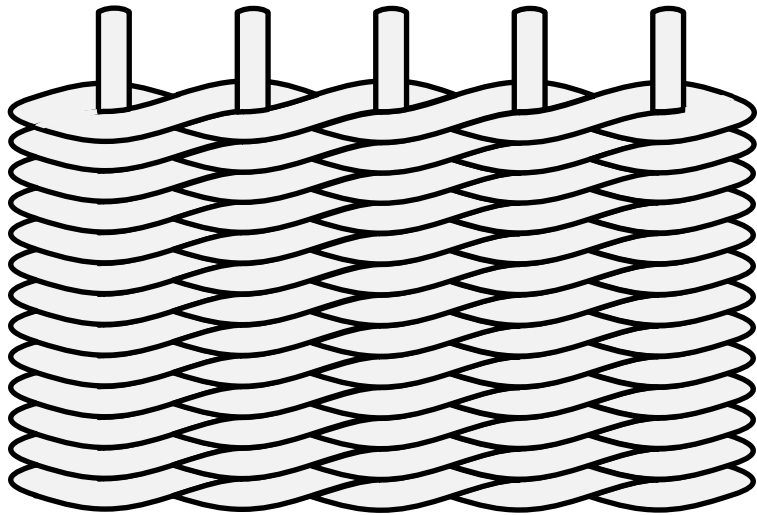

A barrier made of woven twigs. May also be blazoned a “weir.”

Default orientation: fesswise. No proper coloration.

Source: Scheibler Armorial. Artist unknown.

Adapted by Mathghamhain Ua Ruadháin.

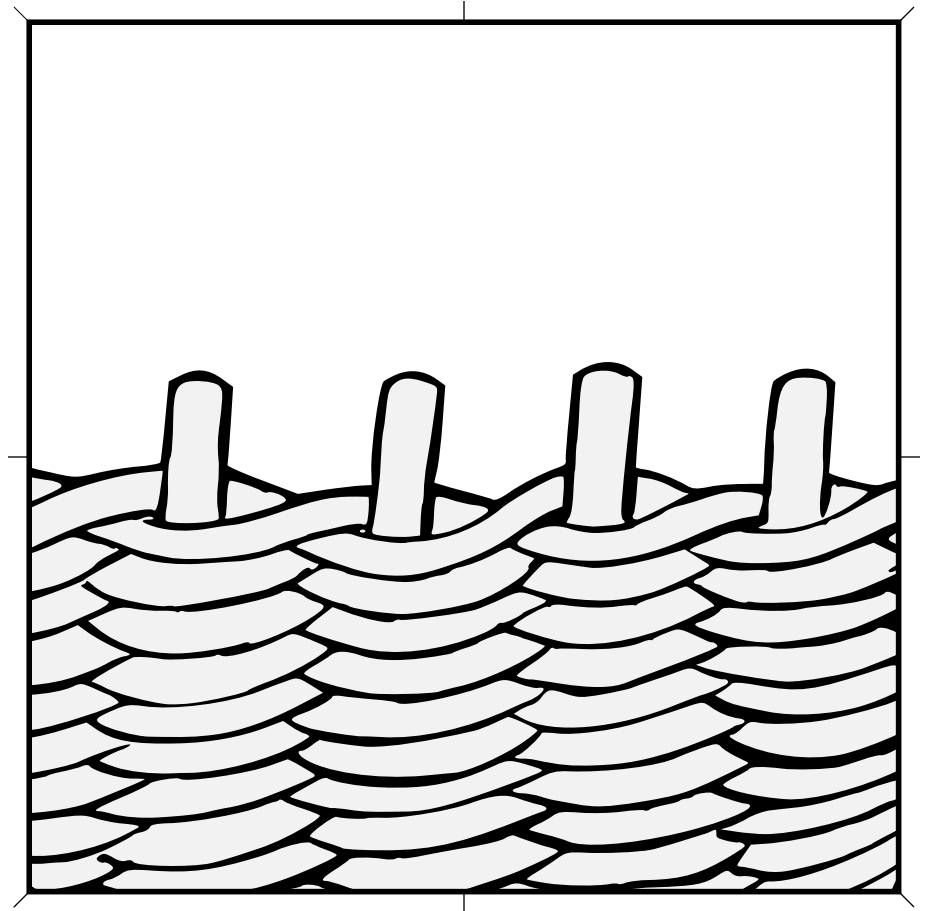
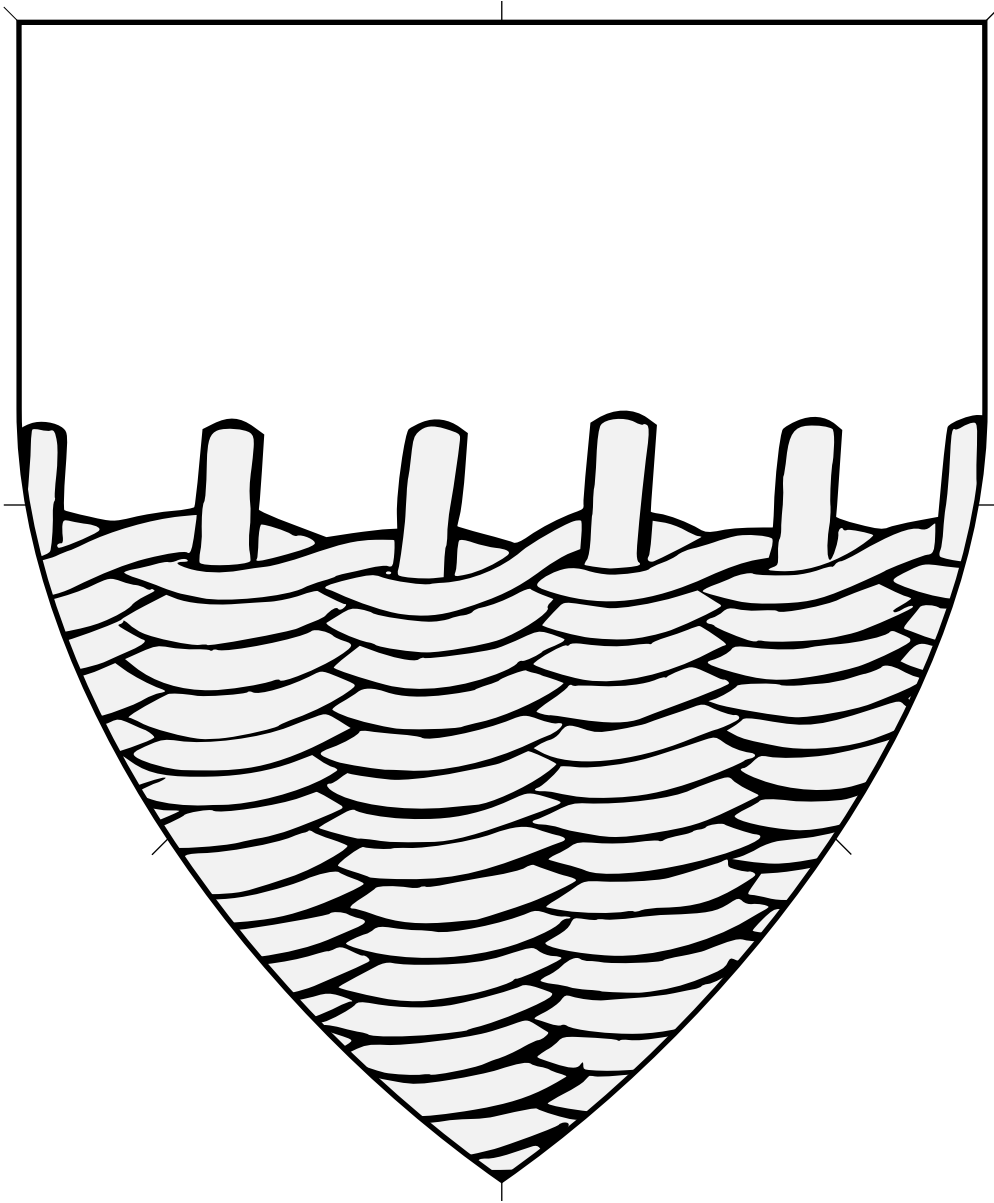

A barrier made of woven twigs. May also be blazoned a “weir.”

Default orientation: fesswise throughout. No proper coloration.

Source: Scheibler Armorial.

Artist unknown. (Arms of Zaunrieder.)

Fence, Wicker, Issuant From Base (1) 19.45

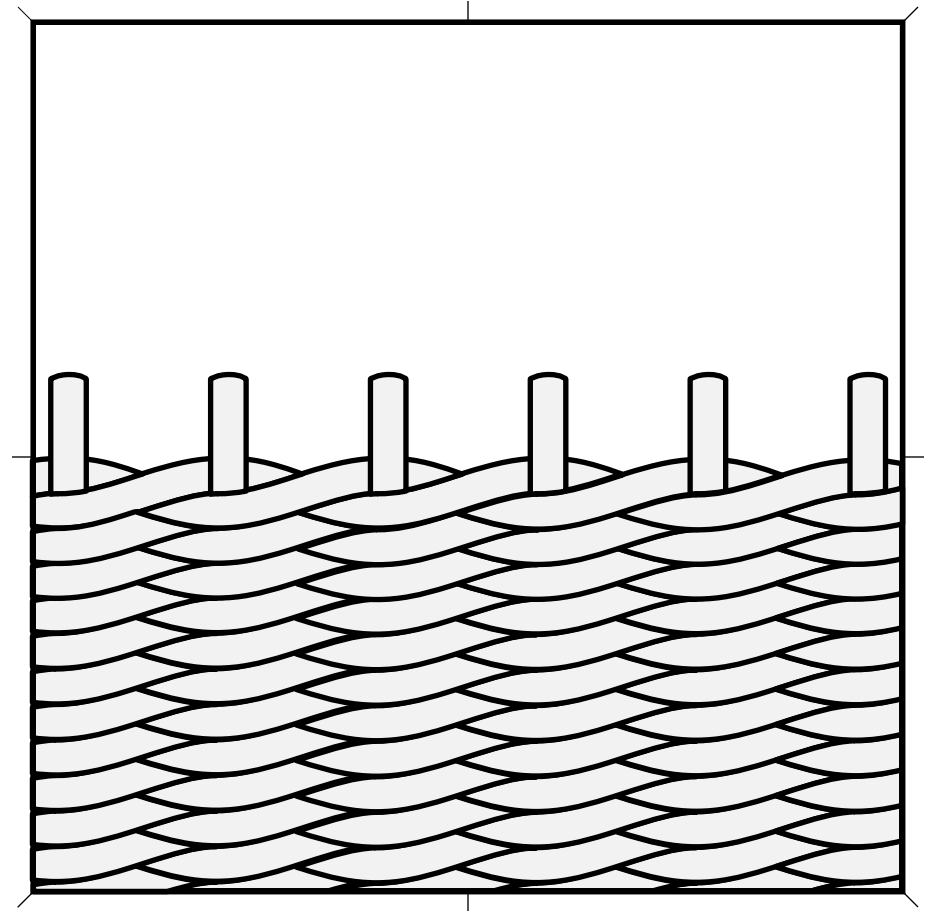
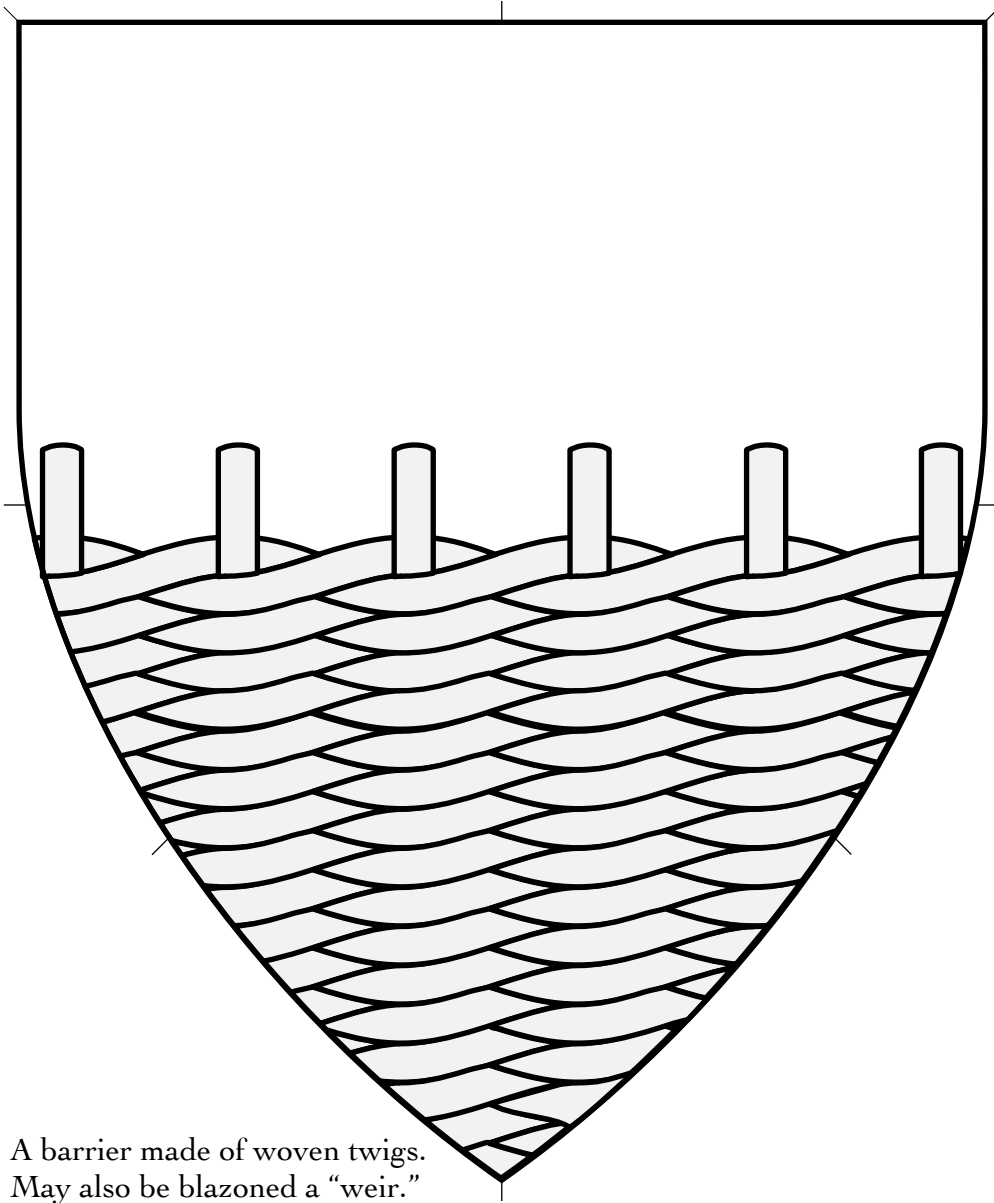

A barrier made of woven twigs.
May also be blazoned a “weir.”

Default orientation: fesswise throughout. No proper coloration.

Source: Scheibler Armorial. Artist unknown. (Arms of Zaurieder.)

Adapted by Mathghamhain
Ua Ruadháin.

Fence, Wicker, Issuant From Base (2) 19.46

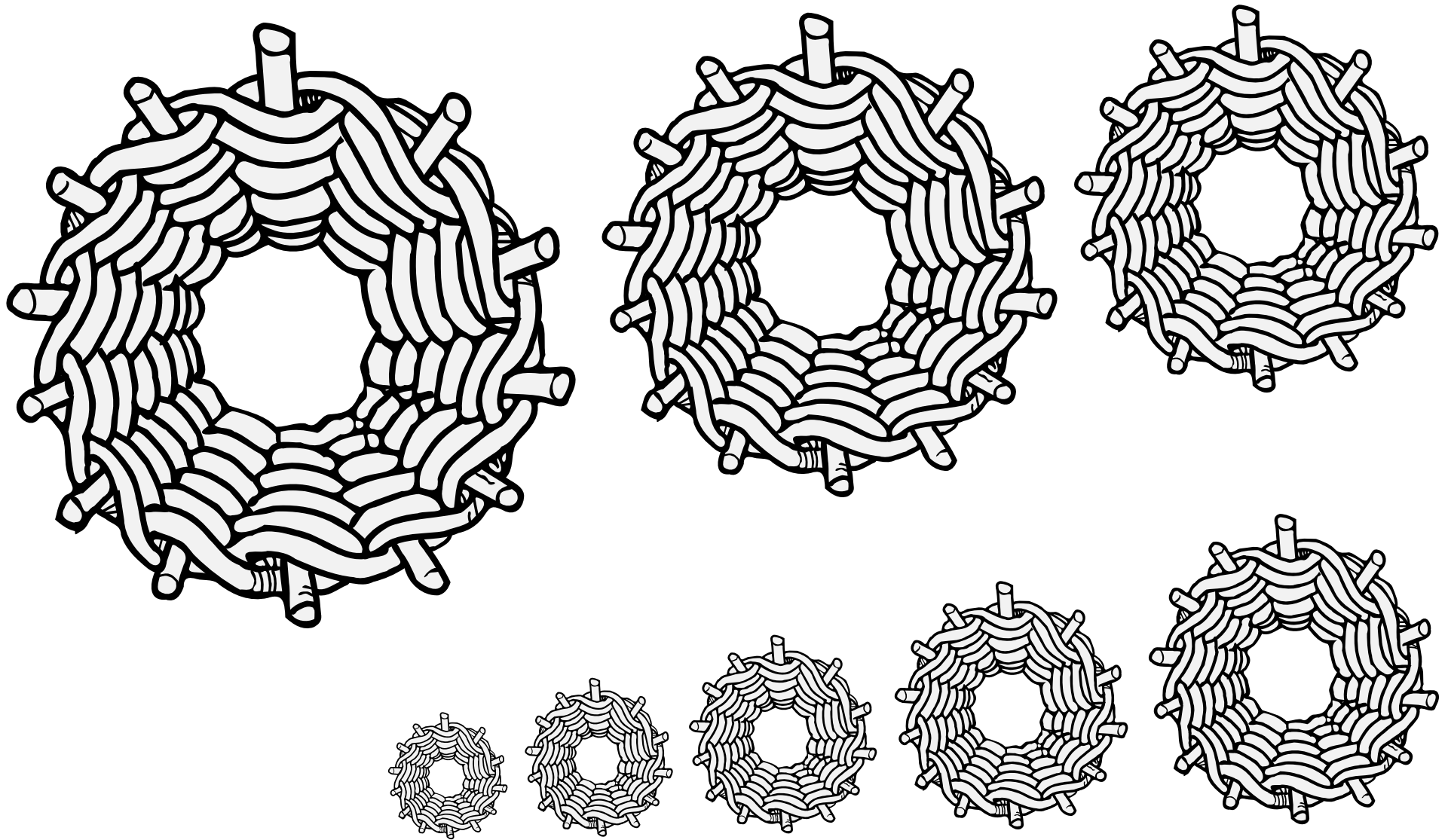

A barrier made of woven twigs. May also be blazoned a “weir.”

Default orientation: fesswise. No proper coloration.

Source: Botenbuch der Bruderschaft St. Christoph auf dem Arlberg.
Artist unknown. Adapted by Vémundr Syvursson.

Fence, Circular Wicker 19.47



A curved piece of metal with a loop, used as an anchor for a wolf trap.

In German heraldry it was also known as a "Wolfsangel," although that name can also refer to the hook that would be attached and baited, which we would blazon a crampon.

Fer-a-loup (1) 19.48

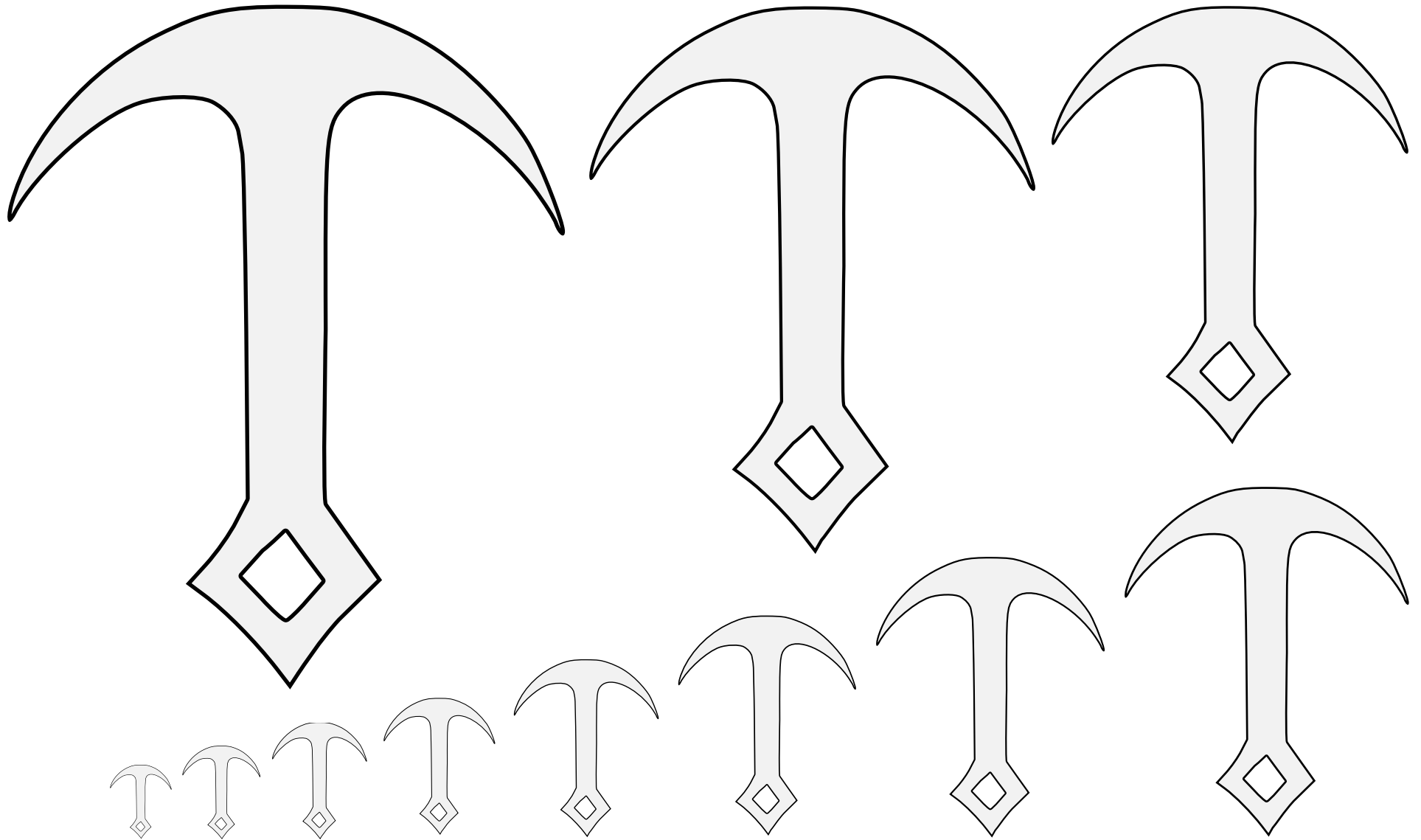

A curved piece of metal with a loop, used as an anchor for a wolf trap.

In German heraldry it was also known as a "Wolfsangel," although that name can also refer to the hook that would be attached and baited, which we would blazon a crampon.

Source: Wappenbuch des Landkreises Hannover. Artist: Gustav Völker.

Fer-a-loup (2) 19.49

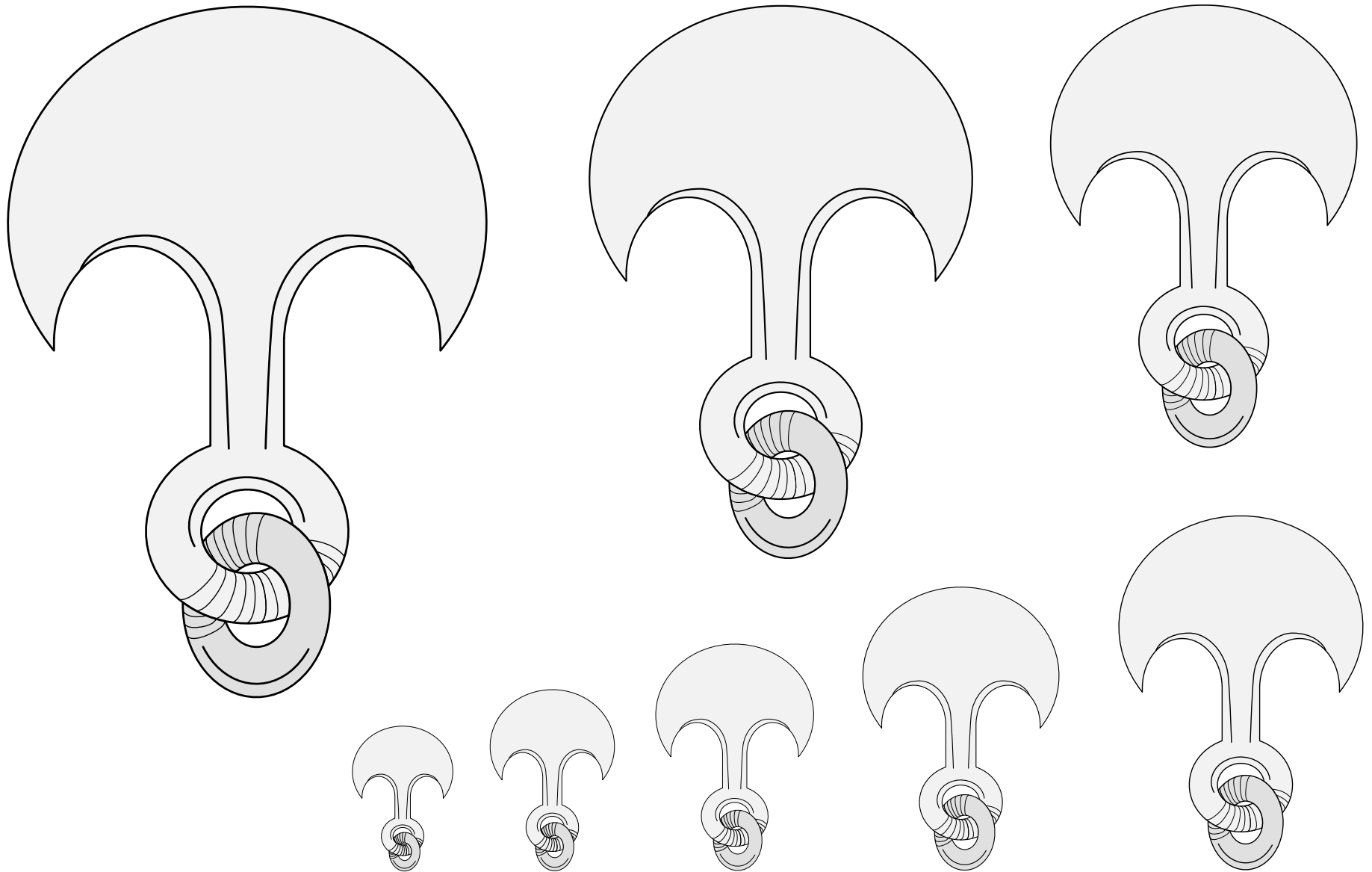

A curved piece of metal with a loop, used as an anchor for a wolf trap.

In German heraldry it was also known as a "Wolfsangel," although that name can also refer to the hook that would be attached and baited, which we would blazon a crampon.

Source: Wappenbuch der Arlberg-Bruderschaft. Artist: Vigil Raber. (Folio 5.)

Fer-a-loup (3) 19.50

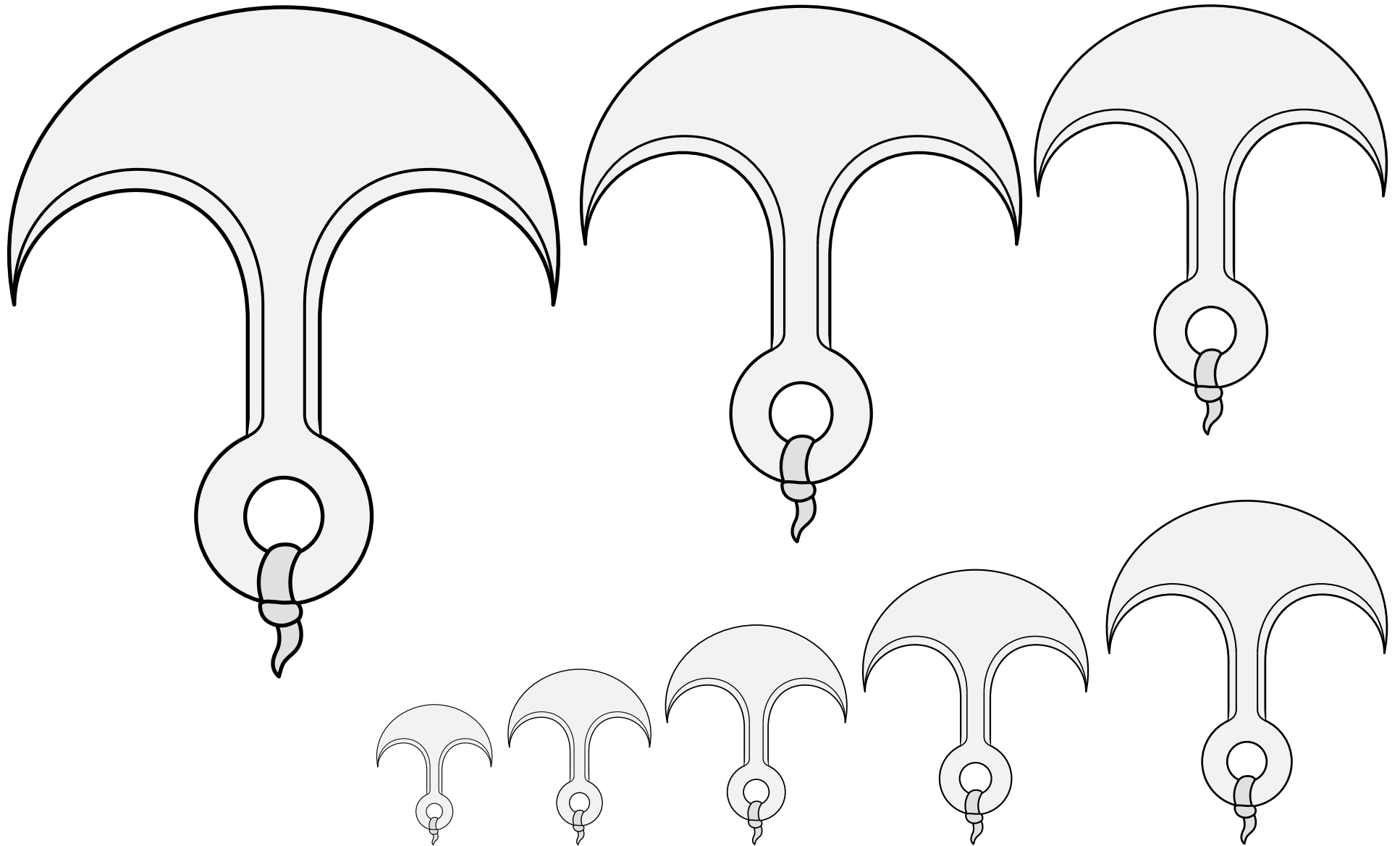

A curved piece of metal with a loop, used as an anchor for a wolf trap.

In German heraldry it was also known as a "Wolfsangel," although that name can also refer to the hook that would be attached and baited, which we would blazon a crampon.

Source: WappenWiki. Artist: Joakim Spuller.

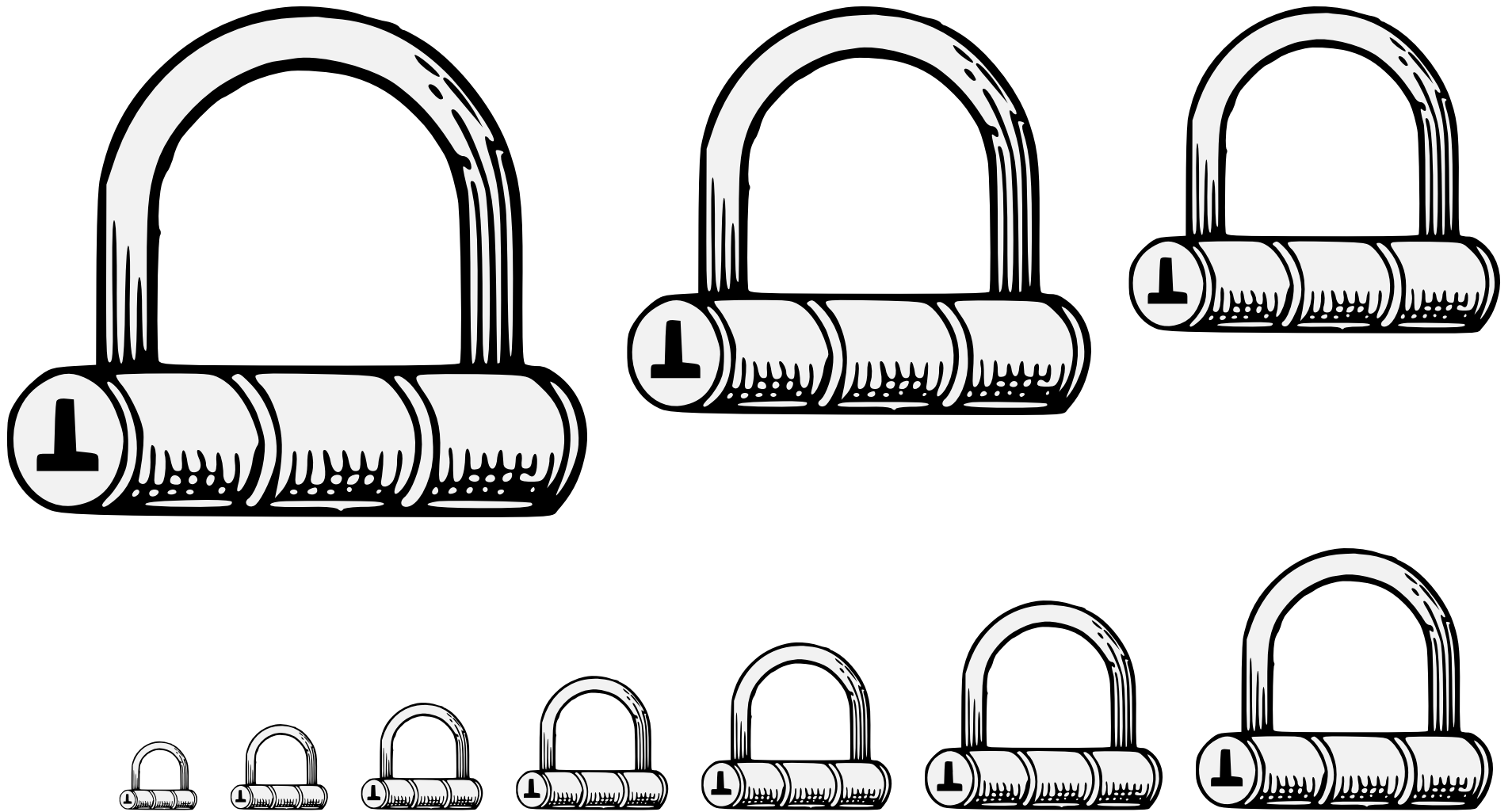

A lock similar to a padlock but intended to lock around a horse's leg to restrain it.

Default orientation: open, bolt to base, keyhole to dexter. No proper coloration.

Source: A Complete Guide to Heraldry.

Artist: Graham Johnston.

Fetterlock, Closed (1) 19.52

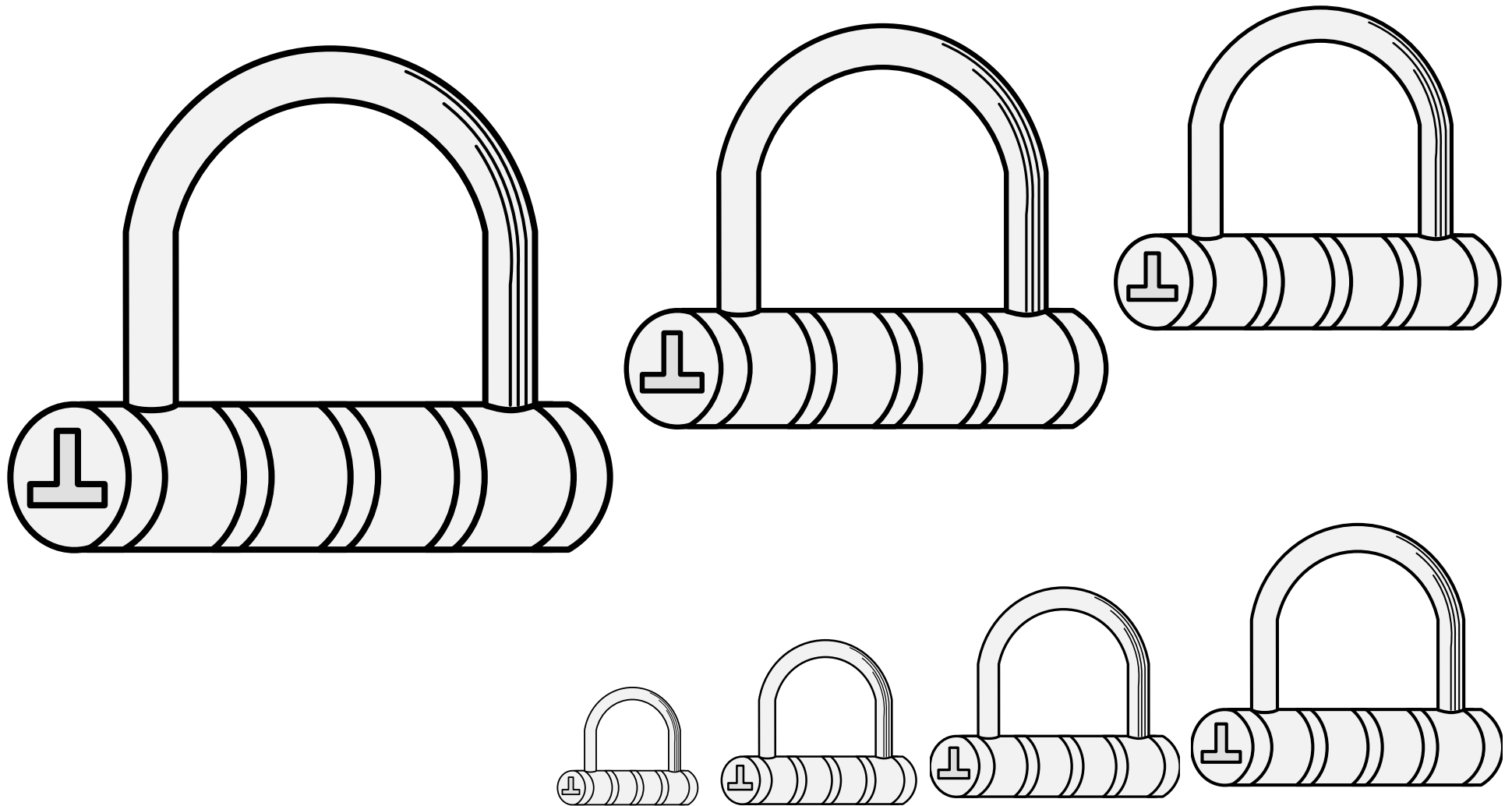

A lock similar to a padlock but intended to lock around a horse's leg to restrain it.

Default orientation: open, bolt to base, keyhole to dexter. No proper coloration.

Source: Viking Answer Lady SVG Images For Heraldry.

Artist: Gunnvôr silfrhárr.

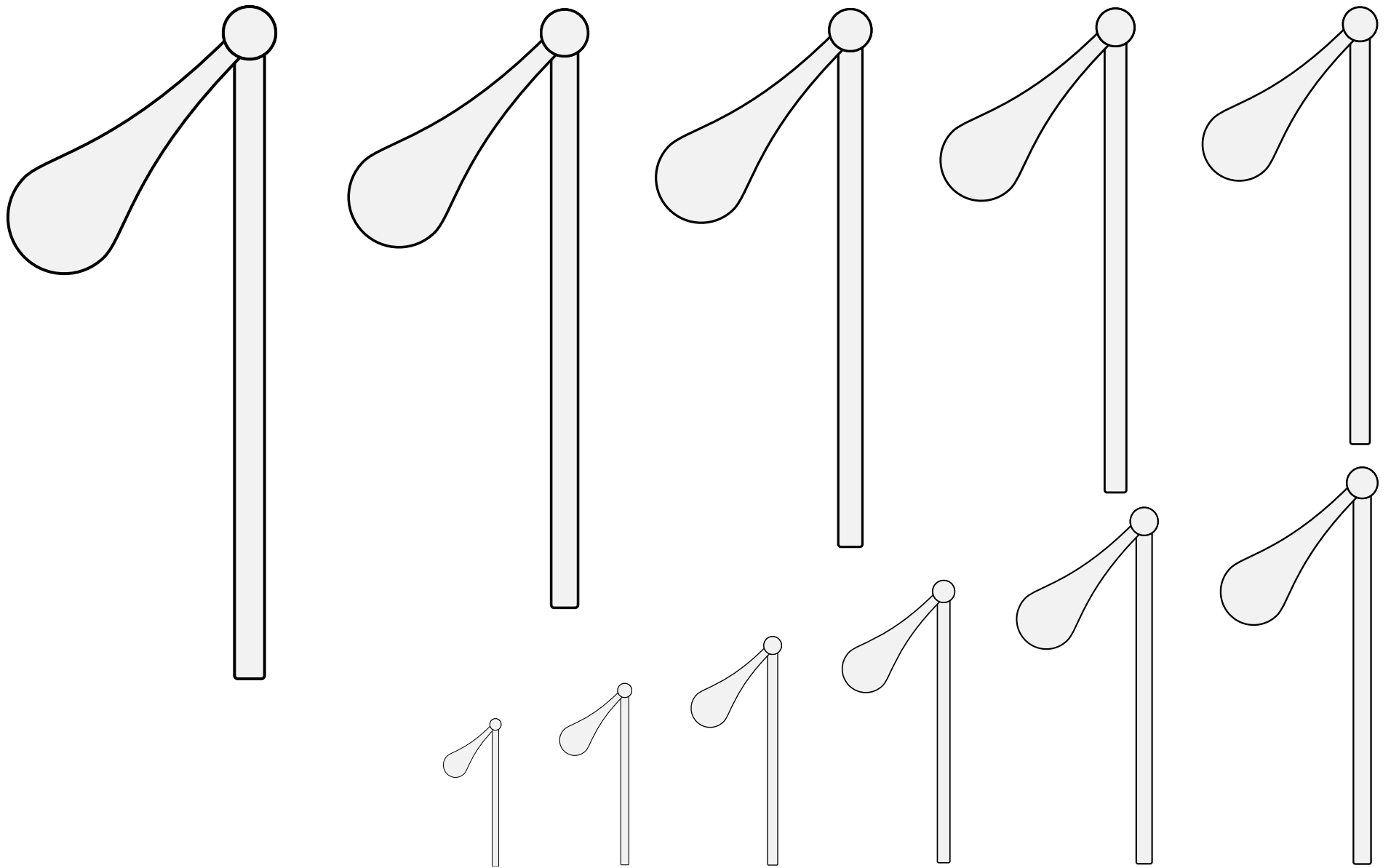

A tool for beating crops to separate the grain from the chaff.
Default orientation: handle to base. No proper coloration.
Source: Zurich Roll. Artist unknown.

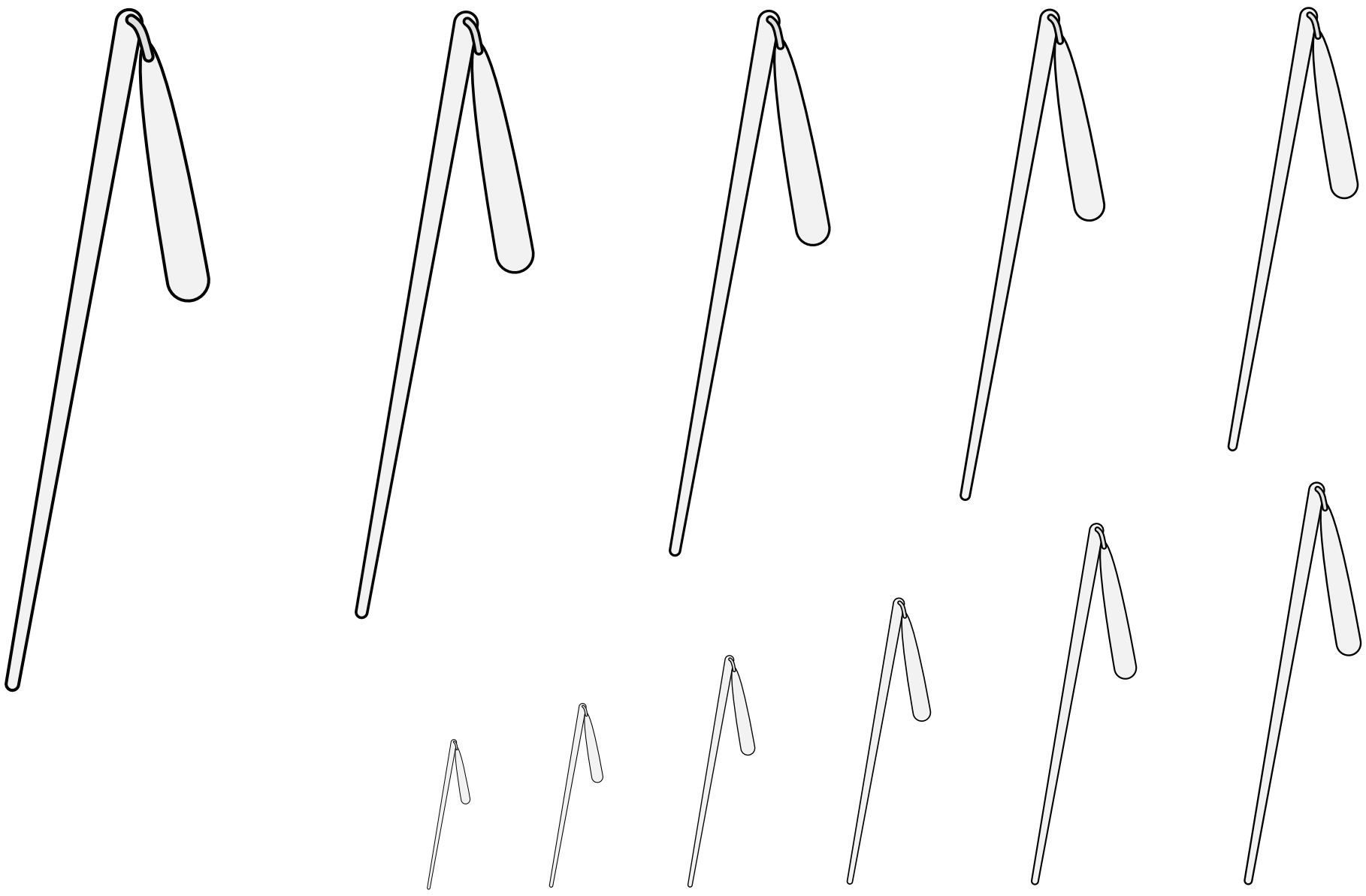

A tool for beating crops to separate the grain from the chaff.
Default orientation: handle to base. No proper coloration.

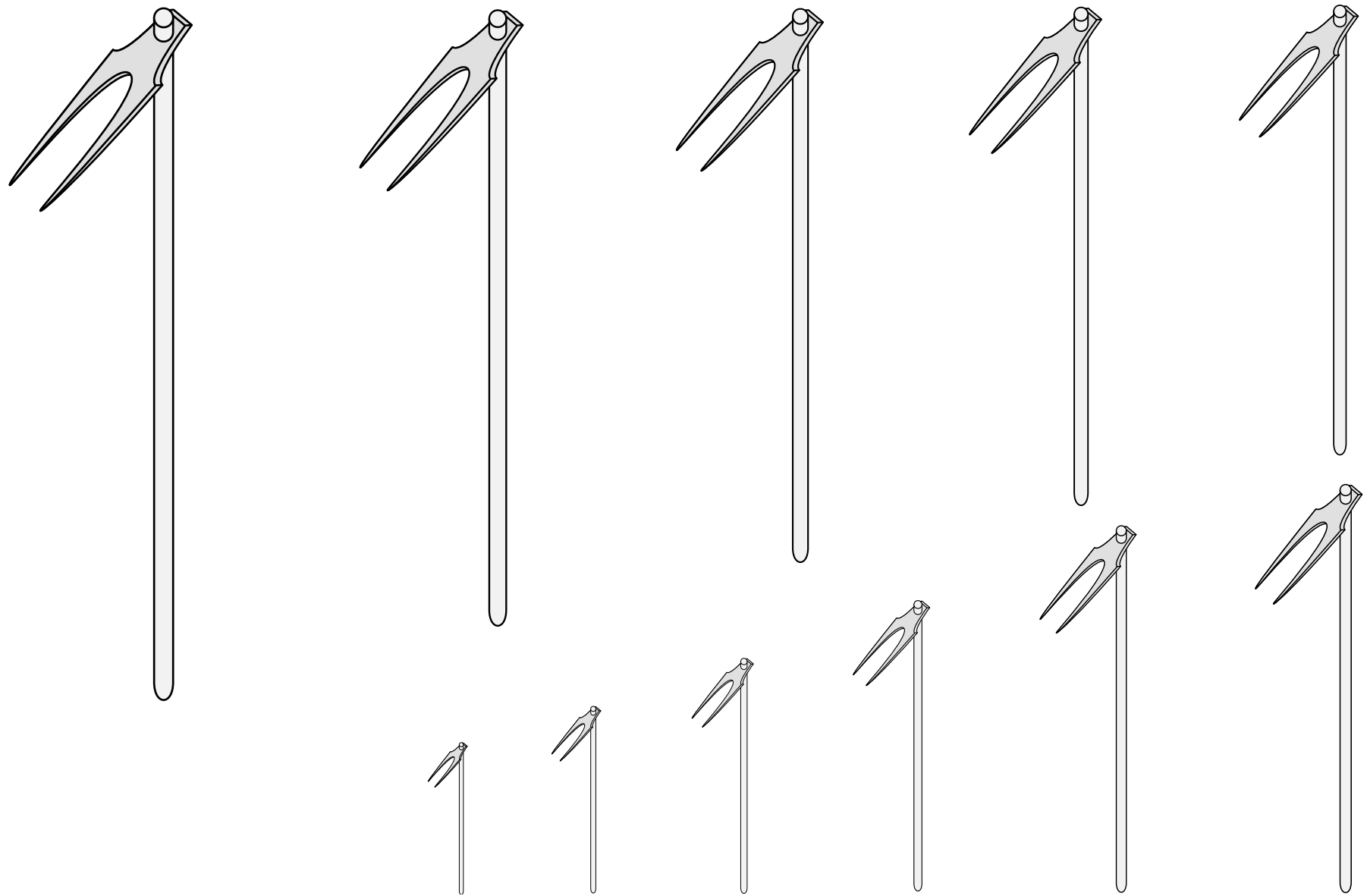

A farming implement used to break up grass and earth before sowing crops.

Default orientation: blade to chief, as of the March 2021 Cover Letter. No proper coloration.

Source: Austrian State Archives. Artist unknown. (Arms of Casstner, 1594.)

Fork Hoe 19.56

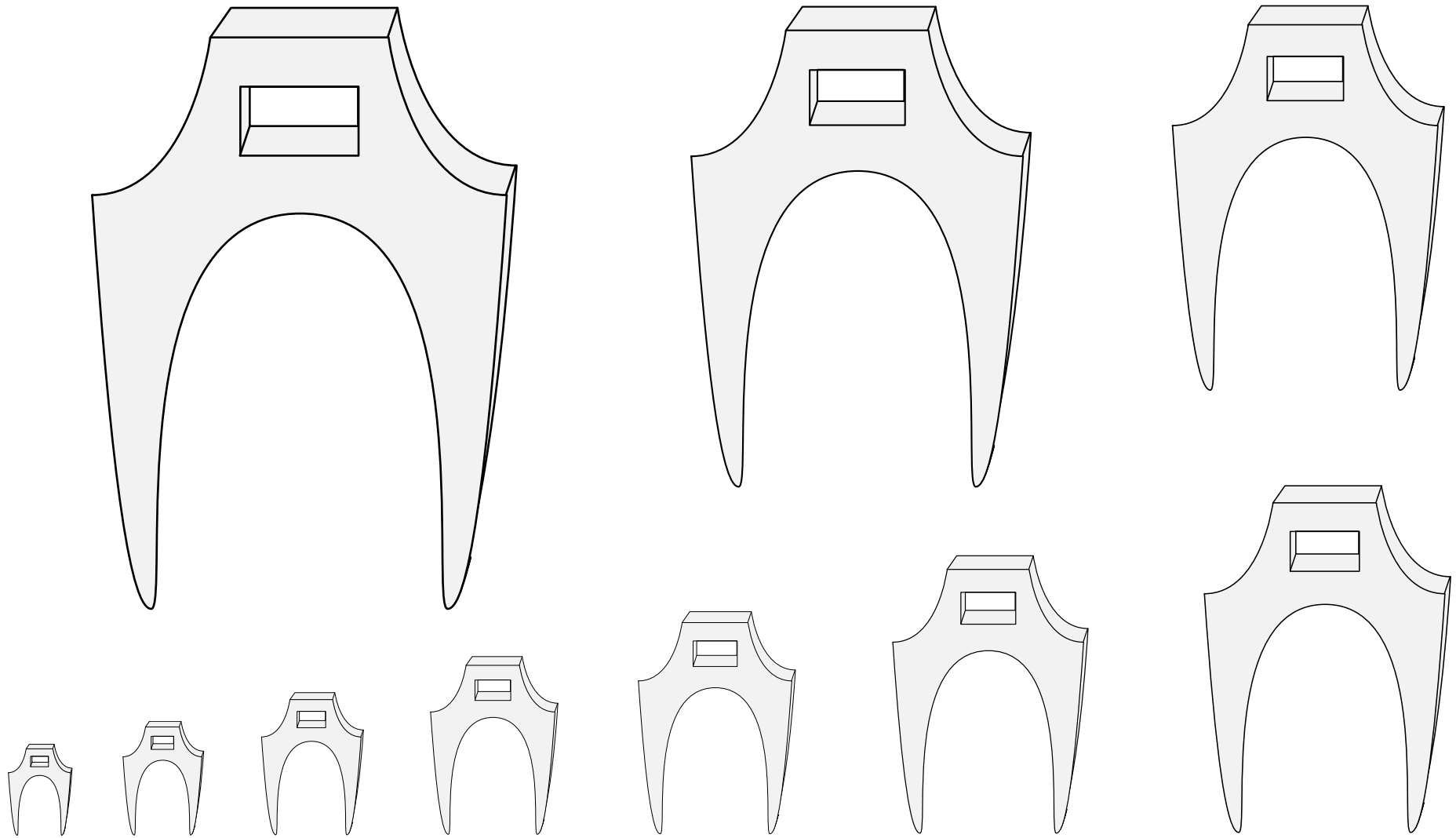

A farming implement used to break up grass and earth before sowing crops.

Default orientation: blade to chief, as of the March 2021 Cover Letter. No proper coloration.

Source: Austrian State Archives. Artist unknown.
(Arms of Weickhardt, 1593.)

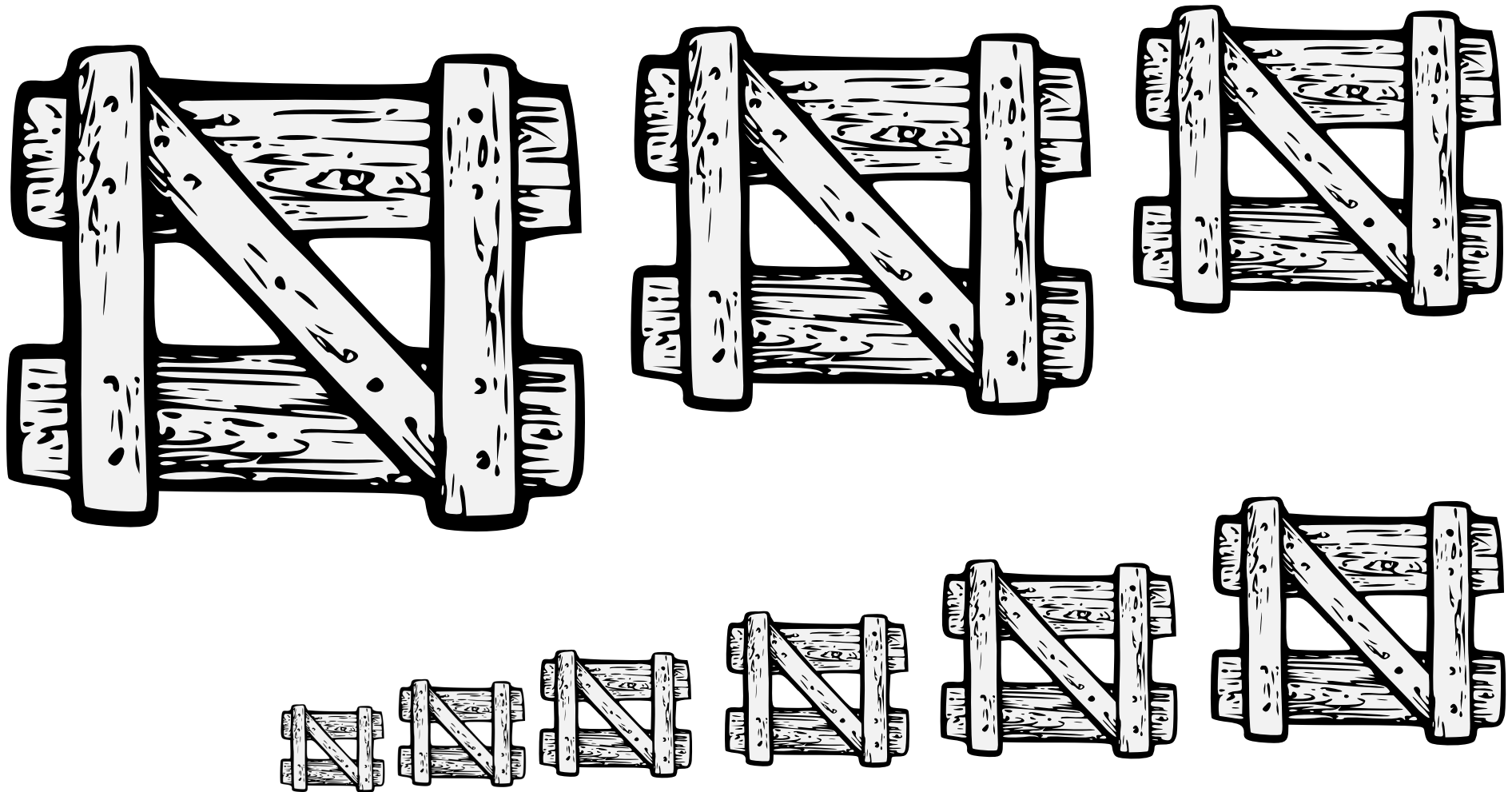

A moveable barrier. Drawn as a set of planks nailed together.

Default orientation: fesswise. Proper coloration: brown wood.

The period German arms of von Haxthausen (depicted in Siebmacher page 186) feature this charge, blazoned a “Wagenflechte,” which seems to be the name for a moveable panel or flap used to close a gap in the woven wicker side wall of a wagon.

Source: Heraldik-Wiki. Artist: Dorado. License: Public domain.

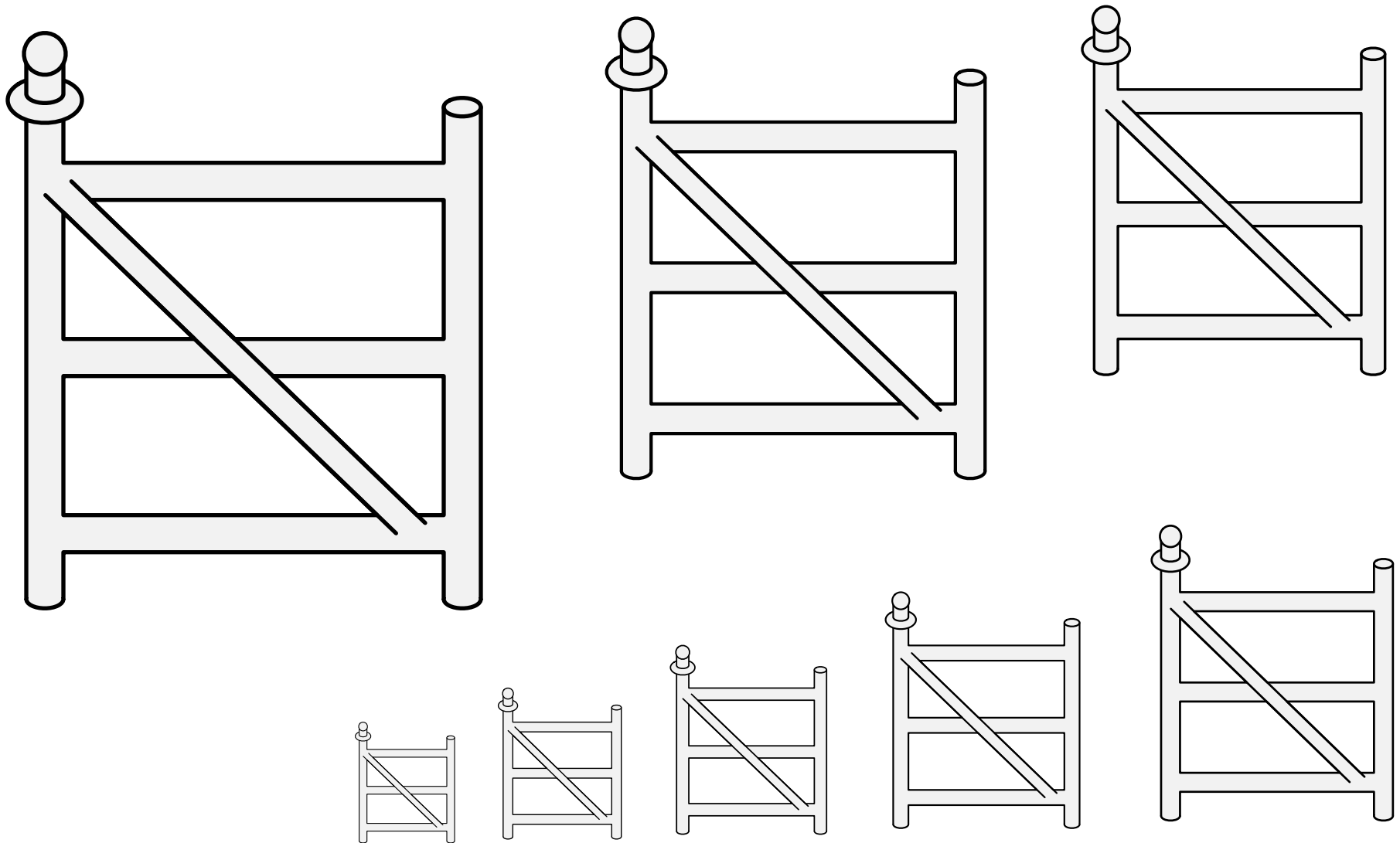

A moveable barrier. Drawn as a set of planks nailed together.

Default orientation: fesswise. Proper coloration: brown wood.

The period German arms of von Haxthausen (depicted in Siebmacher page 186) feature this charge, blazoned a “Wagenflechte,” which seems to be the name for a moveable panel or flap used to close a gap in the woven wicker side wall of a wagon.

Source: Wappenbuch der Arlberg-Bruderschaft. Artist: Vigil Raber. (Folio 84r.)

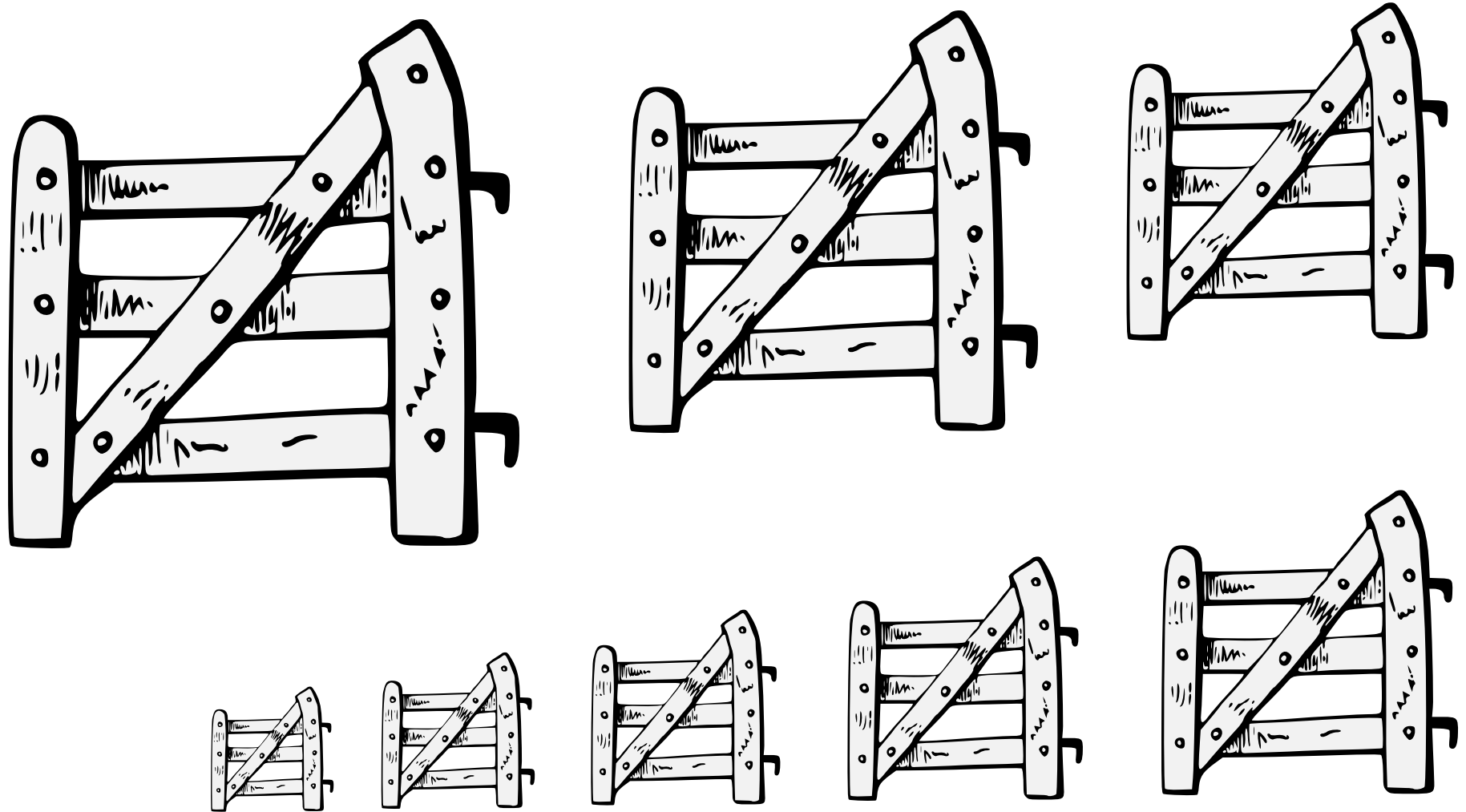

A moveable barrier. Drawn as a set of planks nailed together.

Default orientation: fesswise. Proper coloration: brown wood.

Source: A Glossary of Terms Used in Heraldry. Artist: James or Irene Parker.

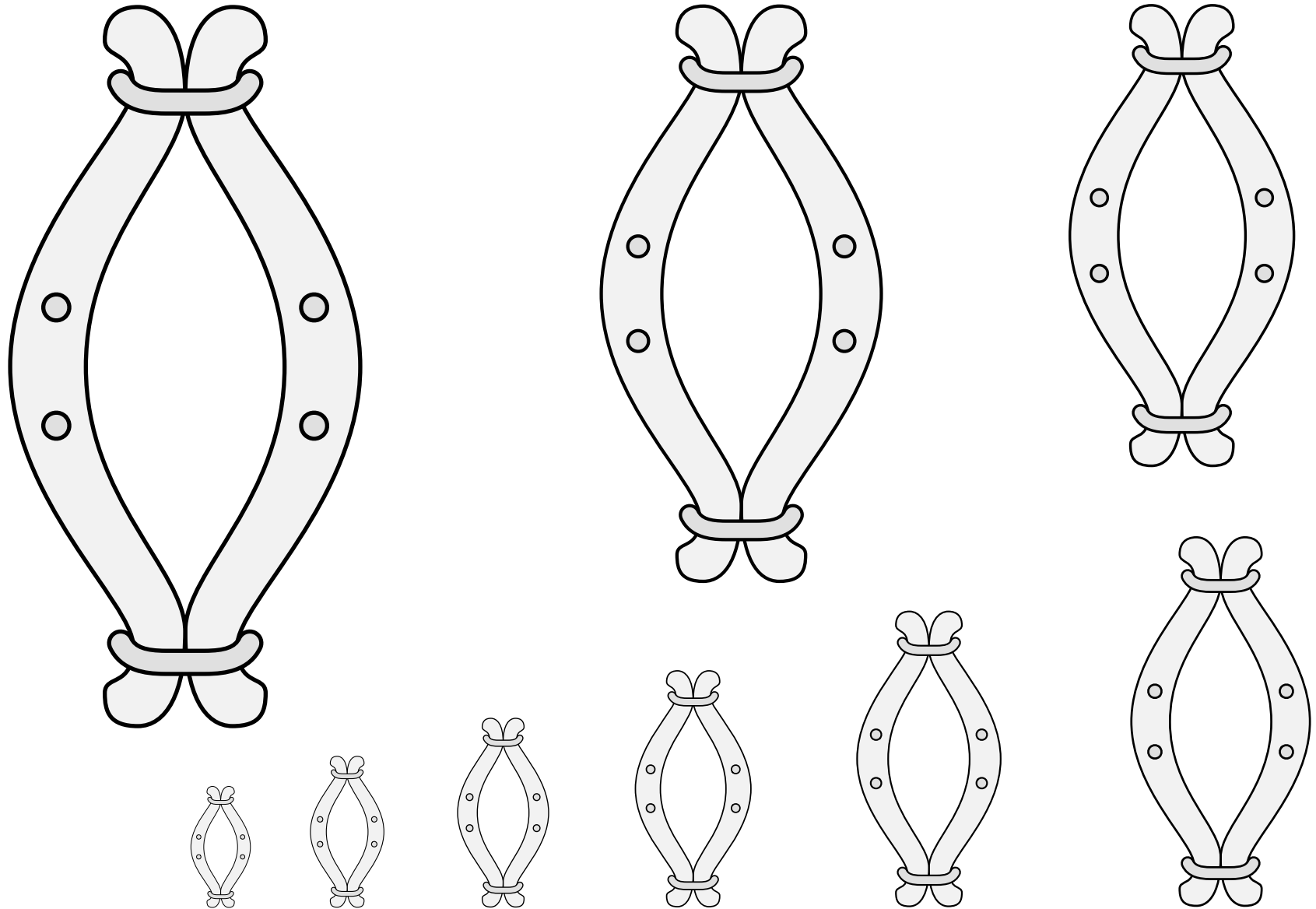

A two-piece collar fastened around the neck of a horse to pull a cart or plow.

Default orientation: palewise. No proper coloration.

Source: Banners, Standards, and Badges. Artist: Thomas Willement.
(Page 265, badge of Marcam.)

Names, Pair of (1) 19.61

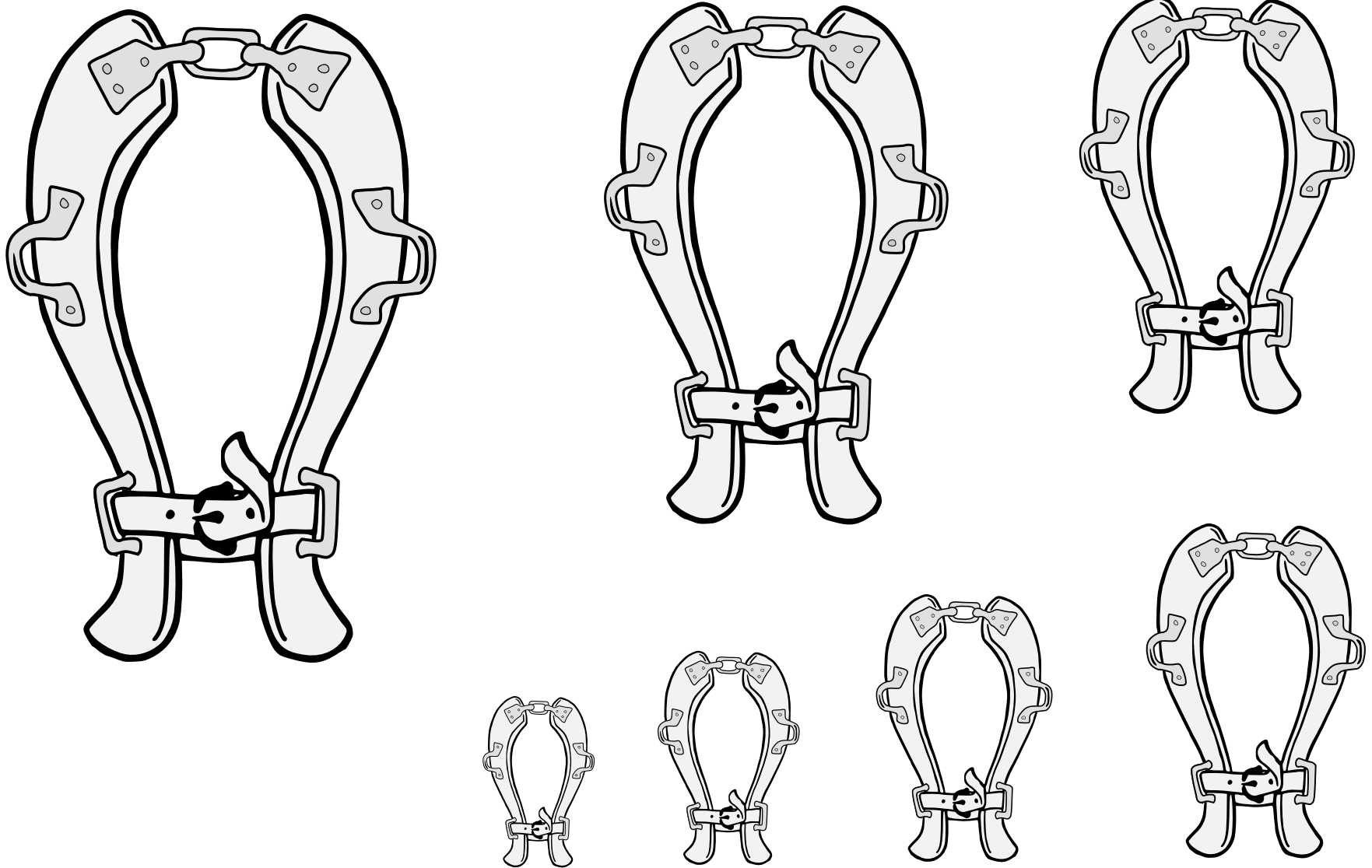

A two-piece collar fastened around the neck of a horse to pull a cart or plow.

Default orientation: palewise. No proper coloration.

Source: Some Feudal Lords and Their Seals. Artist unknown.

Names, Pair of (2) 19.62

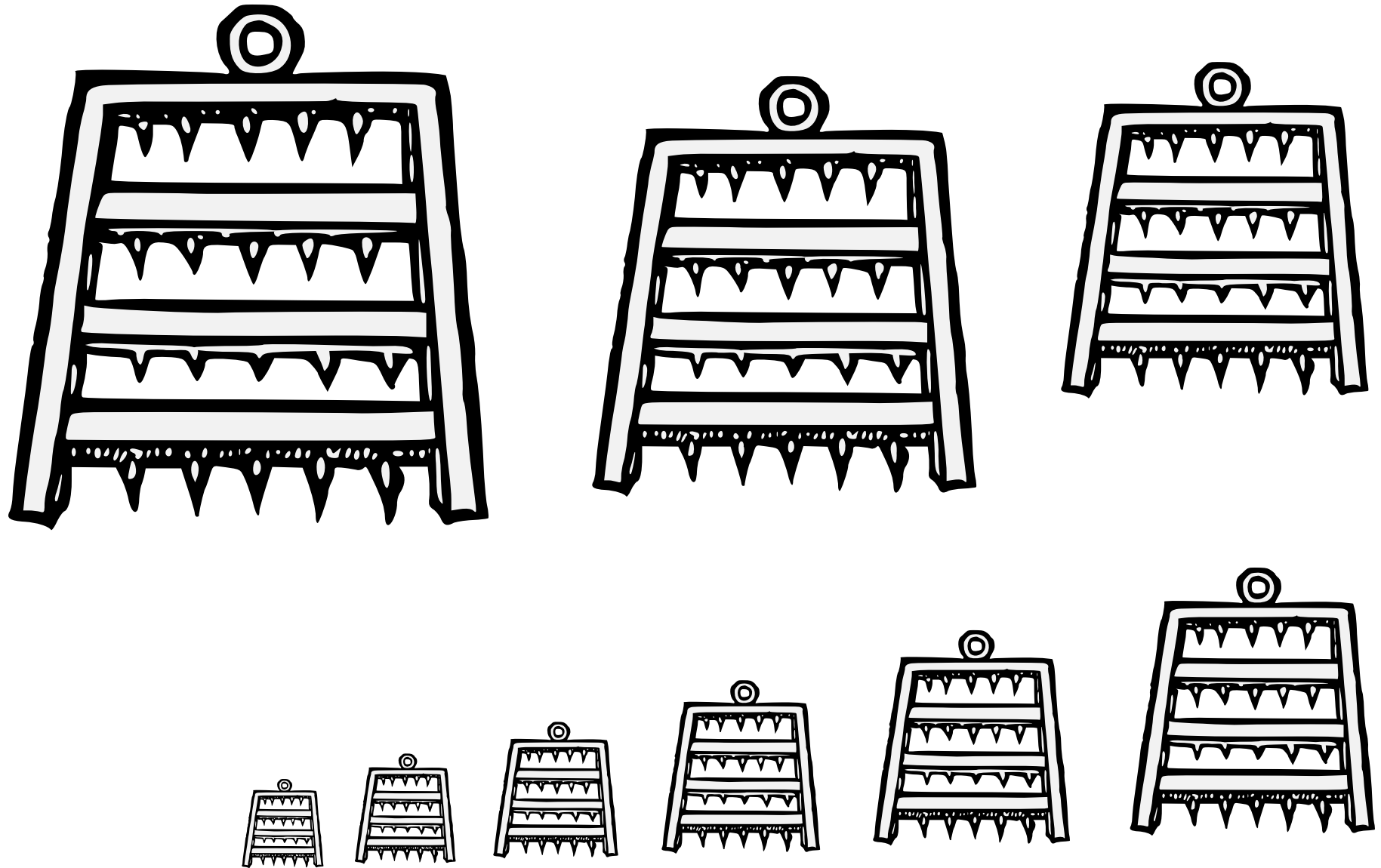

An implement used by farmers, pulled across the field to till the soil.

Default orientation: pulling loop to chief. No proper coloration.

Source: Workes of Armorie. Artist: John Bossewell.

Harrow (1) 19.63

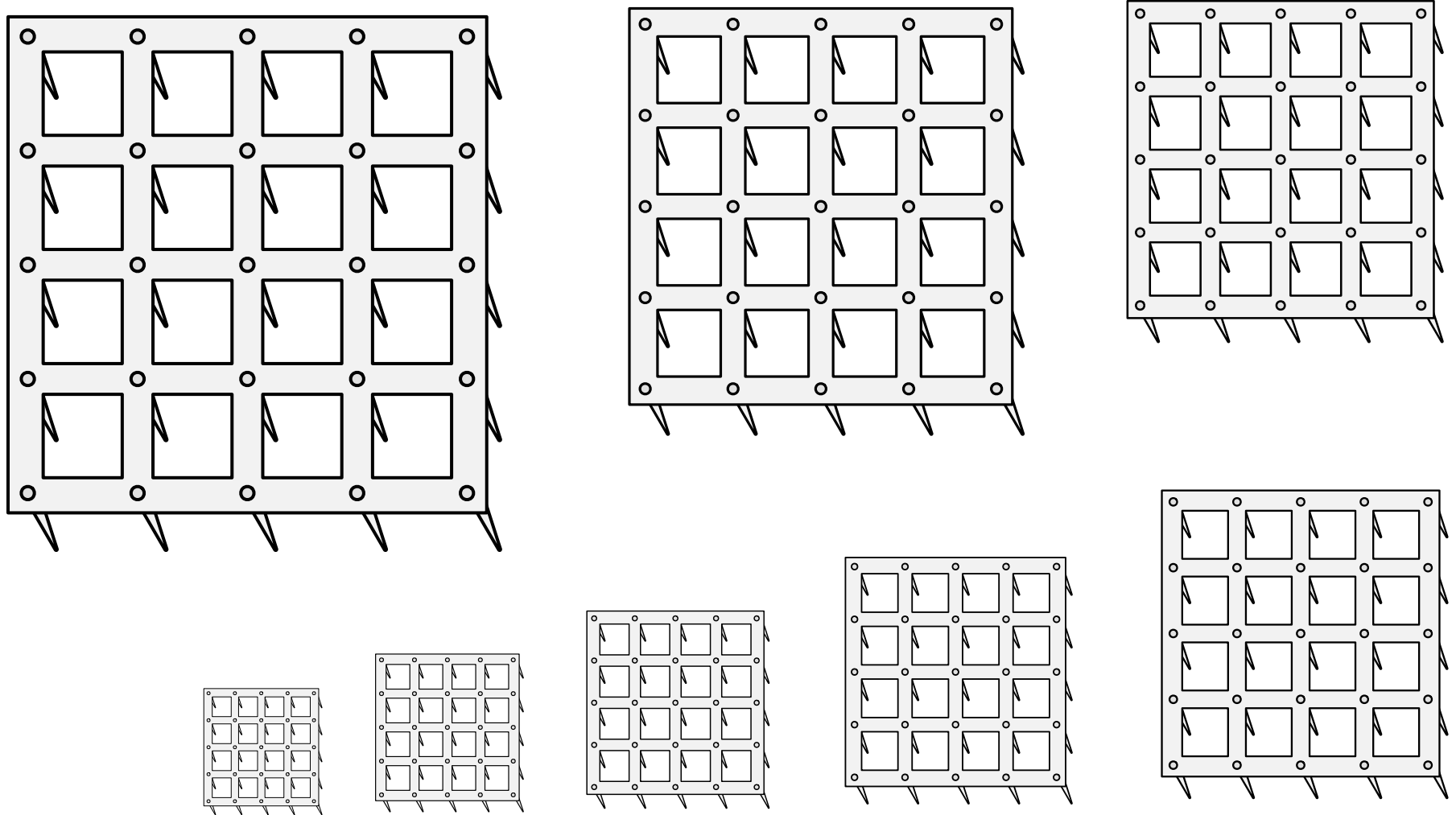

An implement used by farmers, pulled across the field to till the soil.

Default orientation: pulling loop to chief. No proper coloration.

Source: Encyclopædia Heraldica. (Volume 3, plate IX.) Artist unknown.

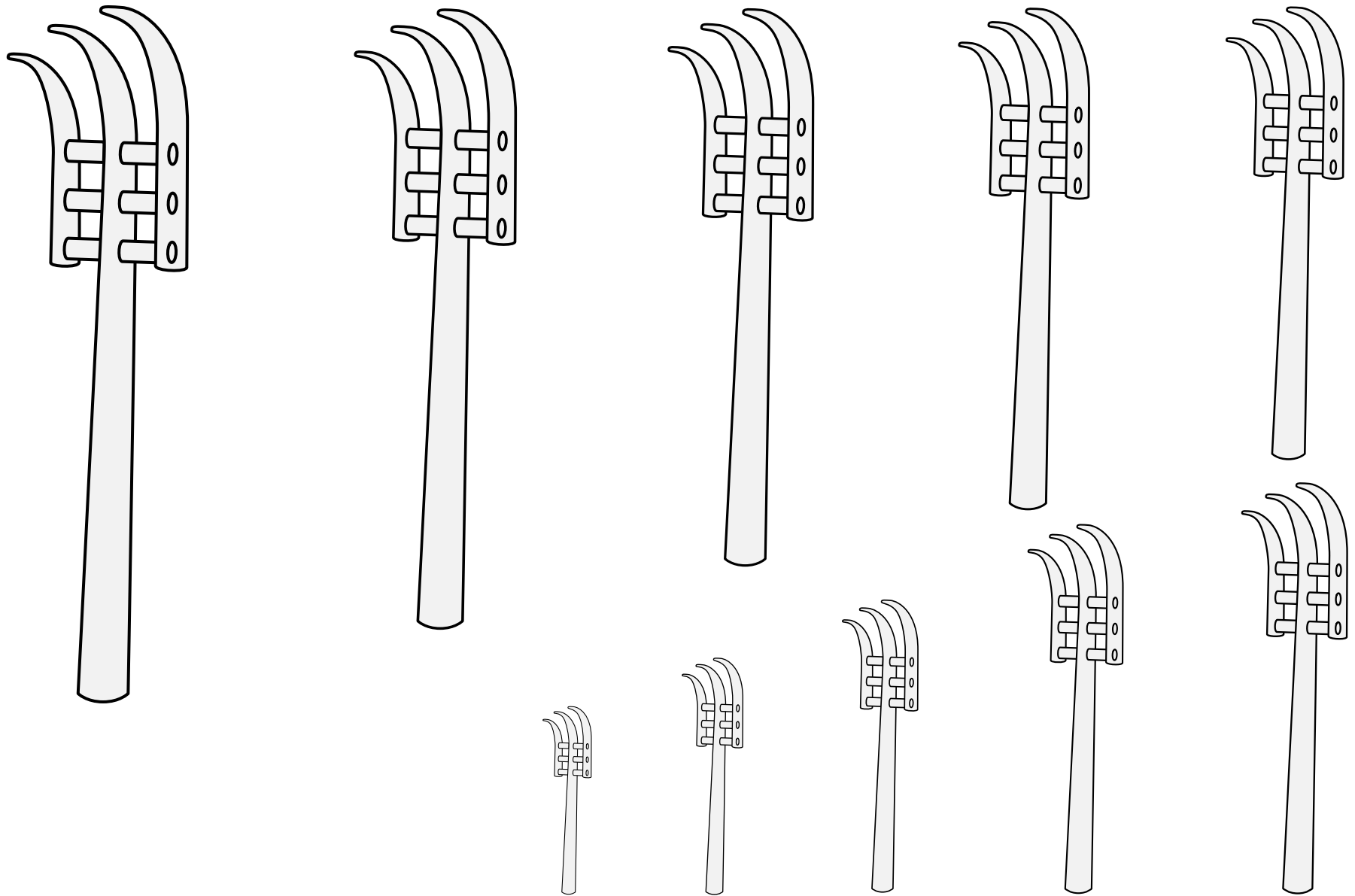

An agricultural tool for lifting dried grass.

Default orientation: handle to base. Proper coloration: brown wood.

Source: Münchner Handschrift. Artist: Unknown. (Folio 53r.)

Hayfork (1) 19.65

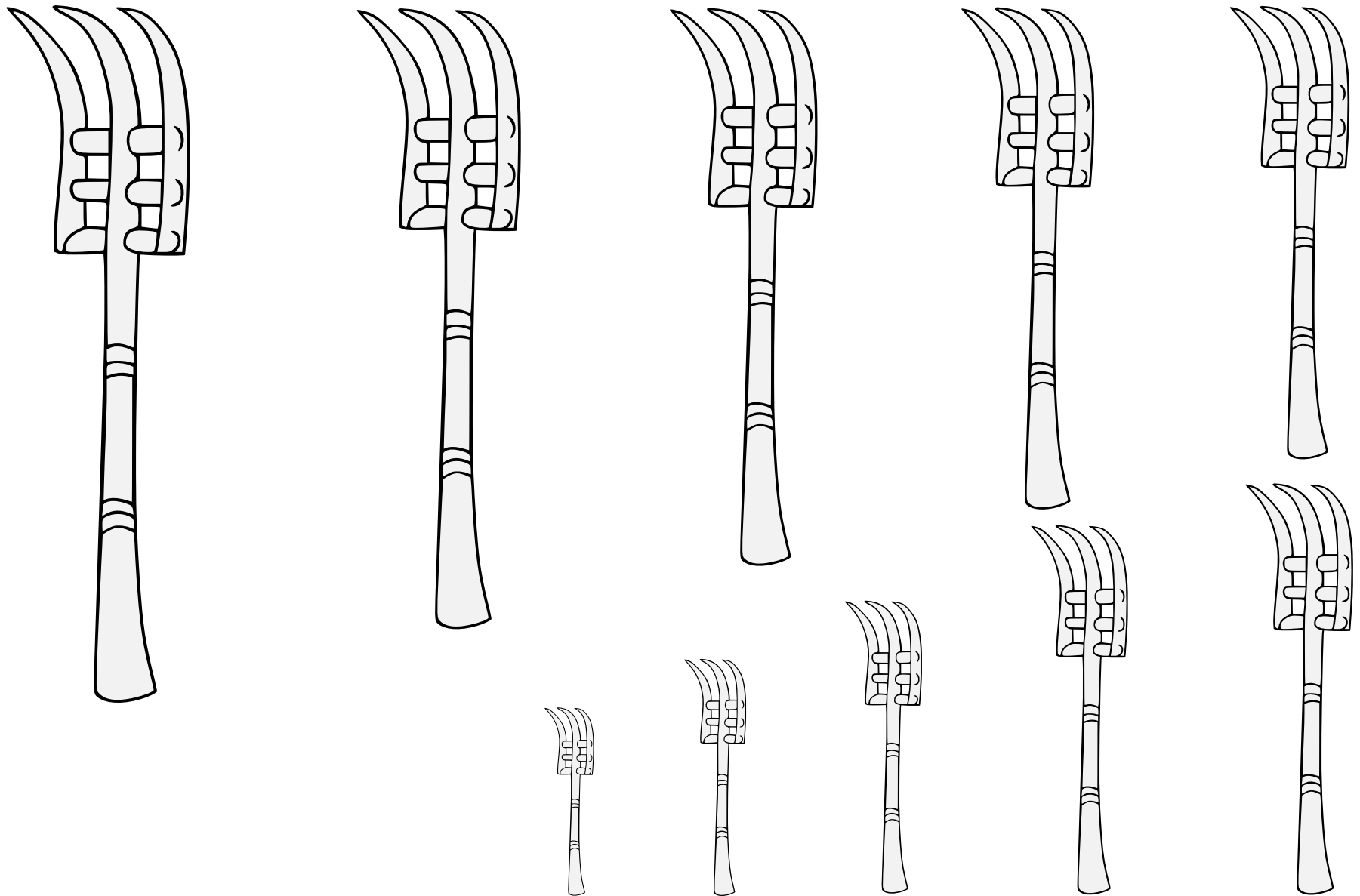

An agricultural tool for lifting dried grass.

Default orientation: handle to base. Proper coloration: brown wood.

Source: Münchner Handschrift. Artist: Unknown. (Folio 53r.)

Adapted by Owen Tegg.

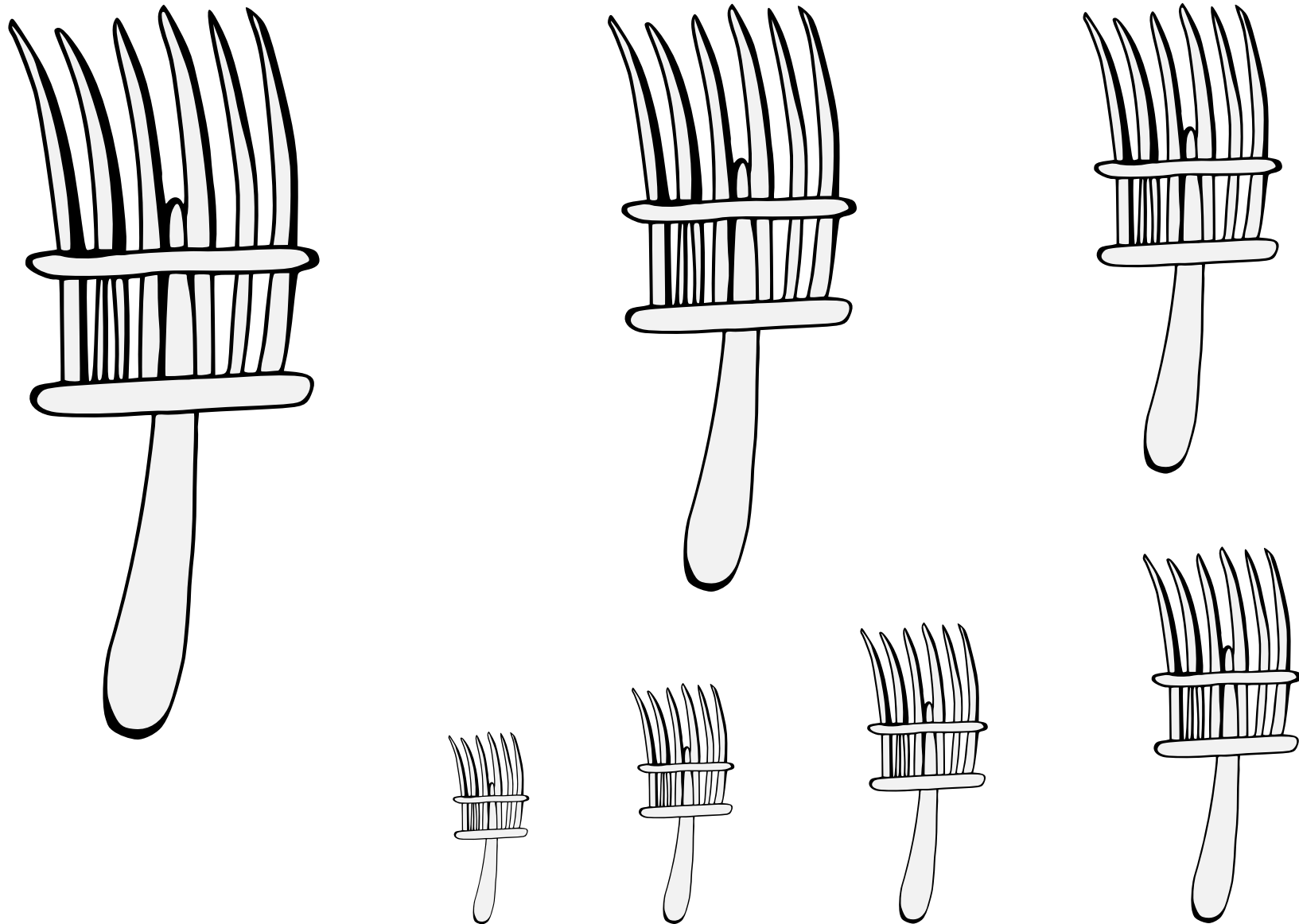

An agricultural tool for lifting dried grass.

Default orientation: handle to base. Proper coloration: brown wood.

Source: The Tudor Pattern Book. Artist unknown. Adapted by Owen Tegg.

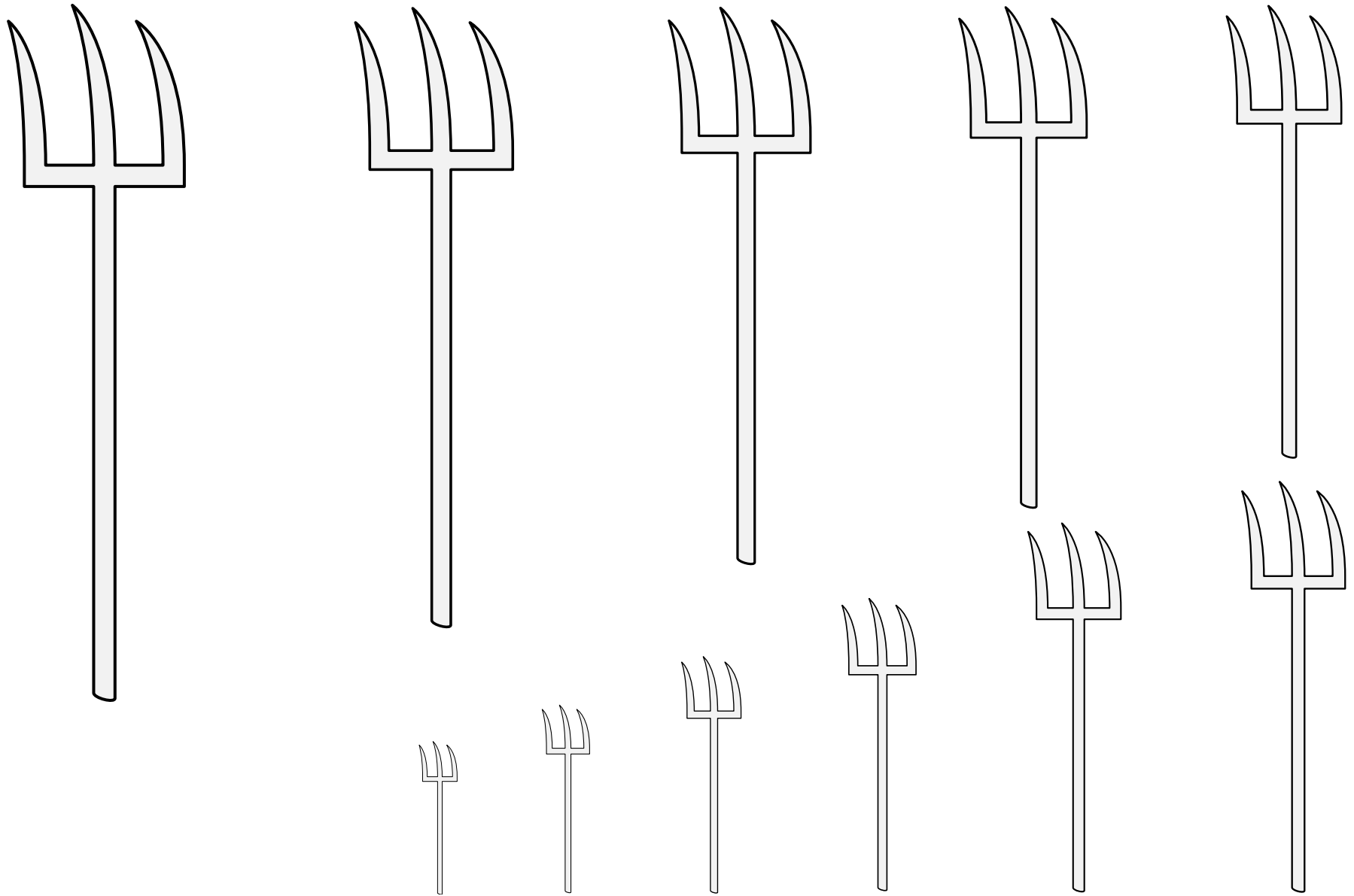

An agricultural tool for lifting dried grass.

Default orientation: handle to base. Proper coloration: brown wood.

Source: Neustifter Wappenbuch. Artist: Vigil Raber. (Page 58.)

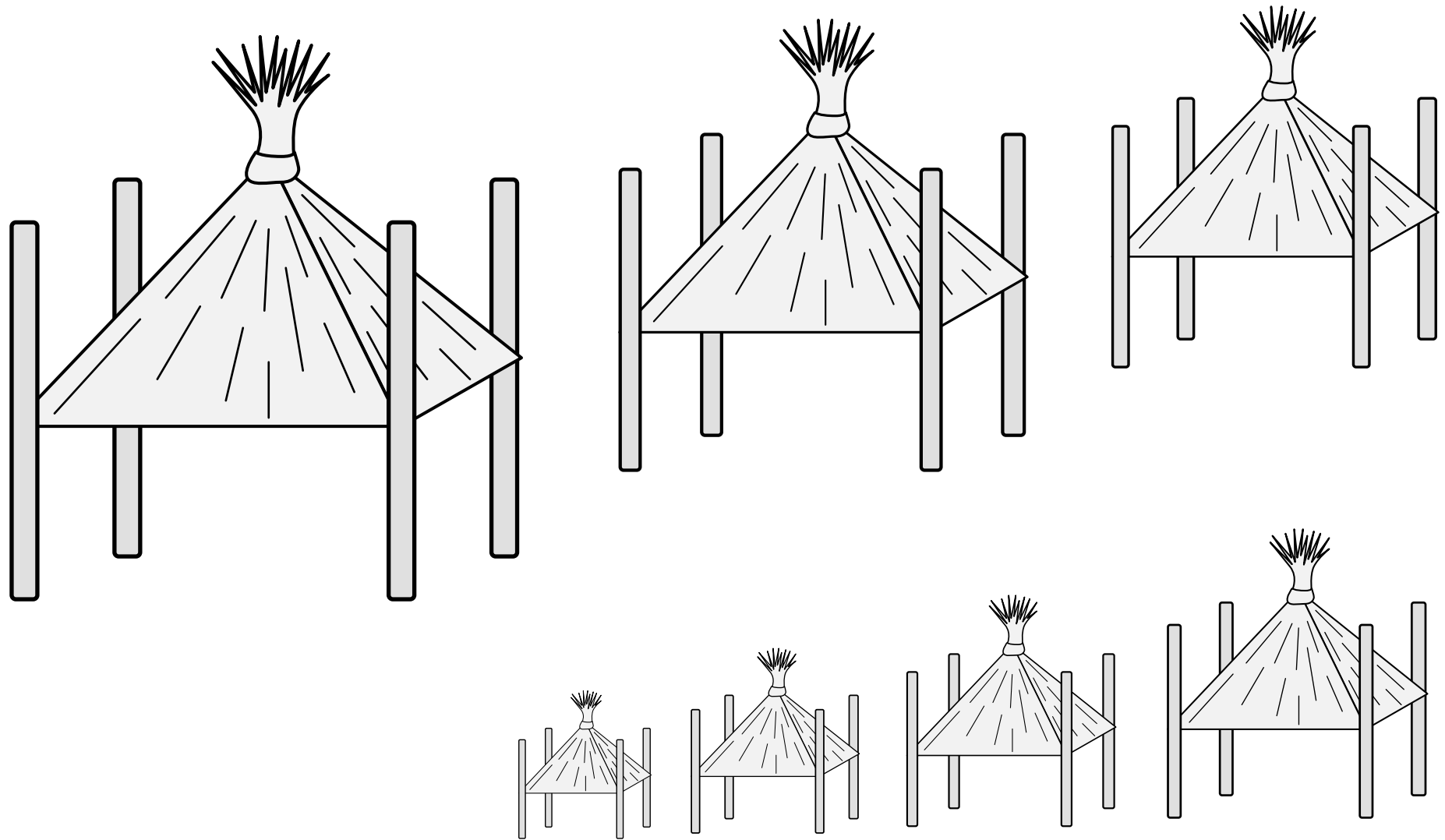

A simple shed used to cover piles of hay to keep them out of the rain while they are drying.

Default orientation: upright. No proper coloration.

Source: Bellenville Armorial. Artist unknown. (Folio 68v.)

Hay House (1) 19.69

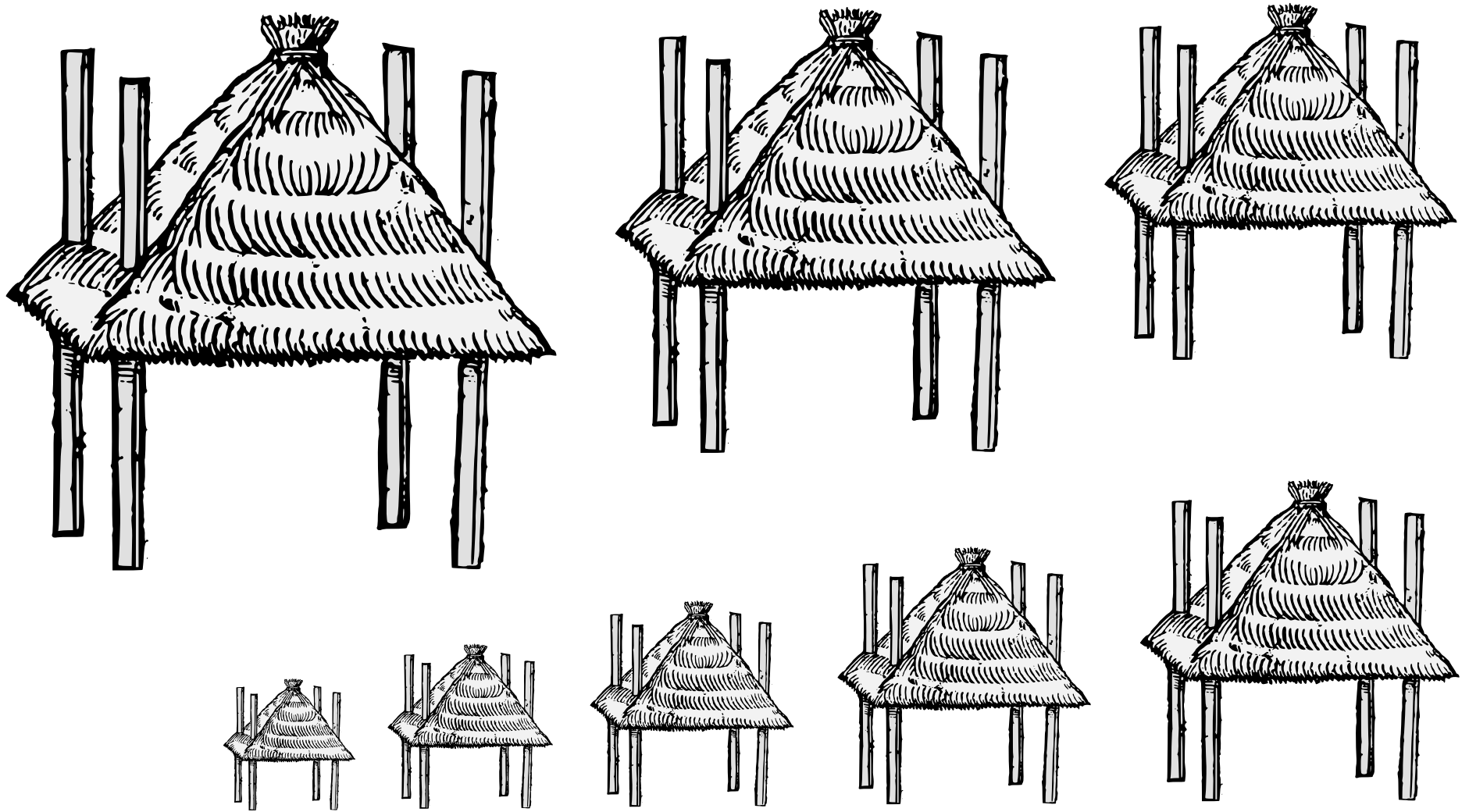

A simple shed used to cover piles of hay to keep them out of the rain while they are drying.

Default orientation: upright. No proper coloration.

Source: Arma Regni Poloniae. Artist unknown.
(Herb of Acervorum or Leszczyc, p. 107.)

Hay House (2) 19.70

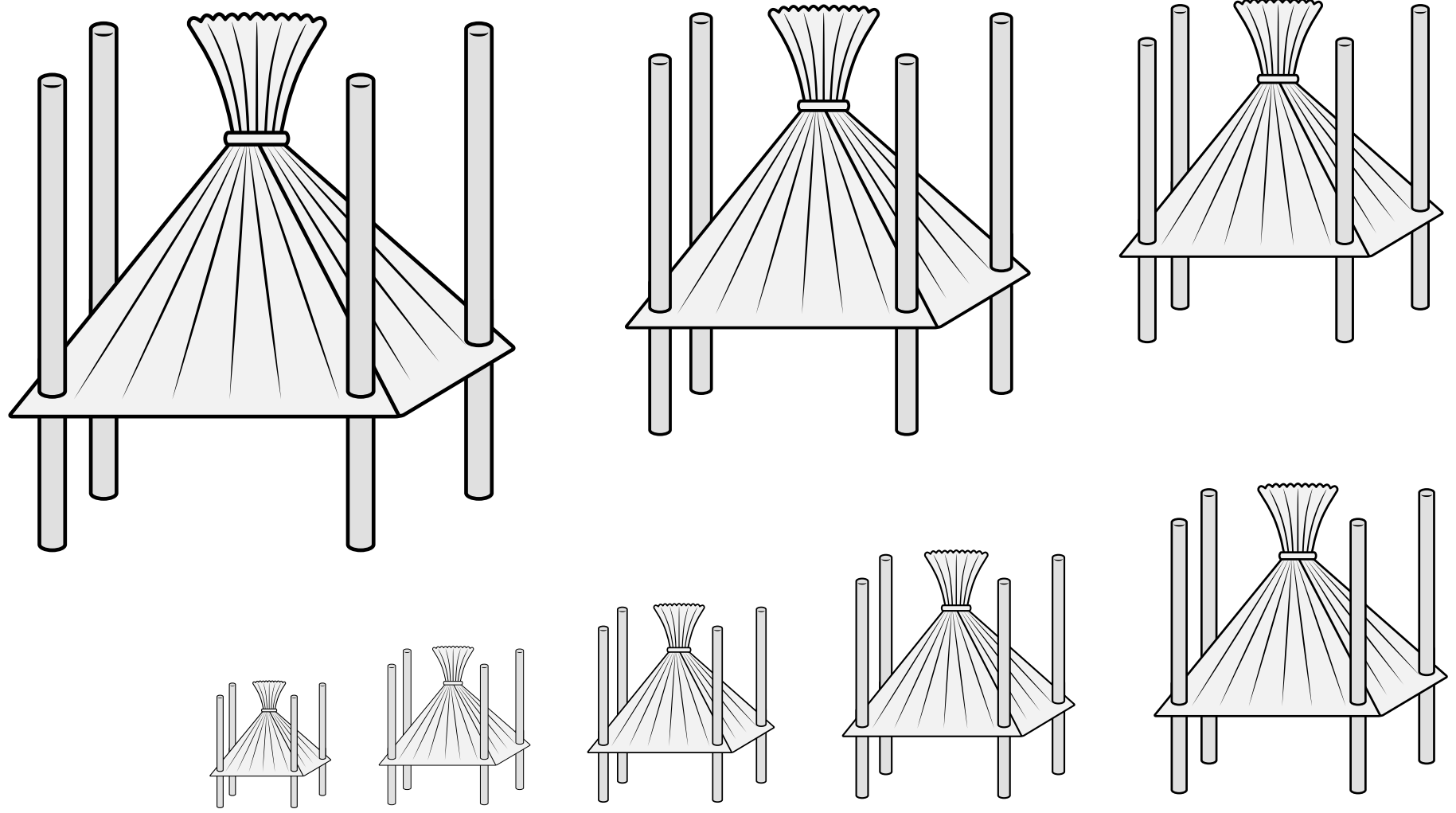

A simple shed used to cover piles of hay to keep them out of the rain while they are drying.

Default orientation: upright. No proper coloration.

Source: WappenWiki. Artist: Joakim Spuller.

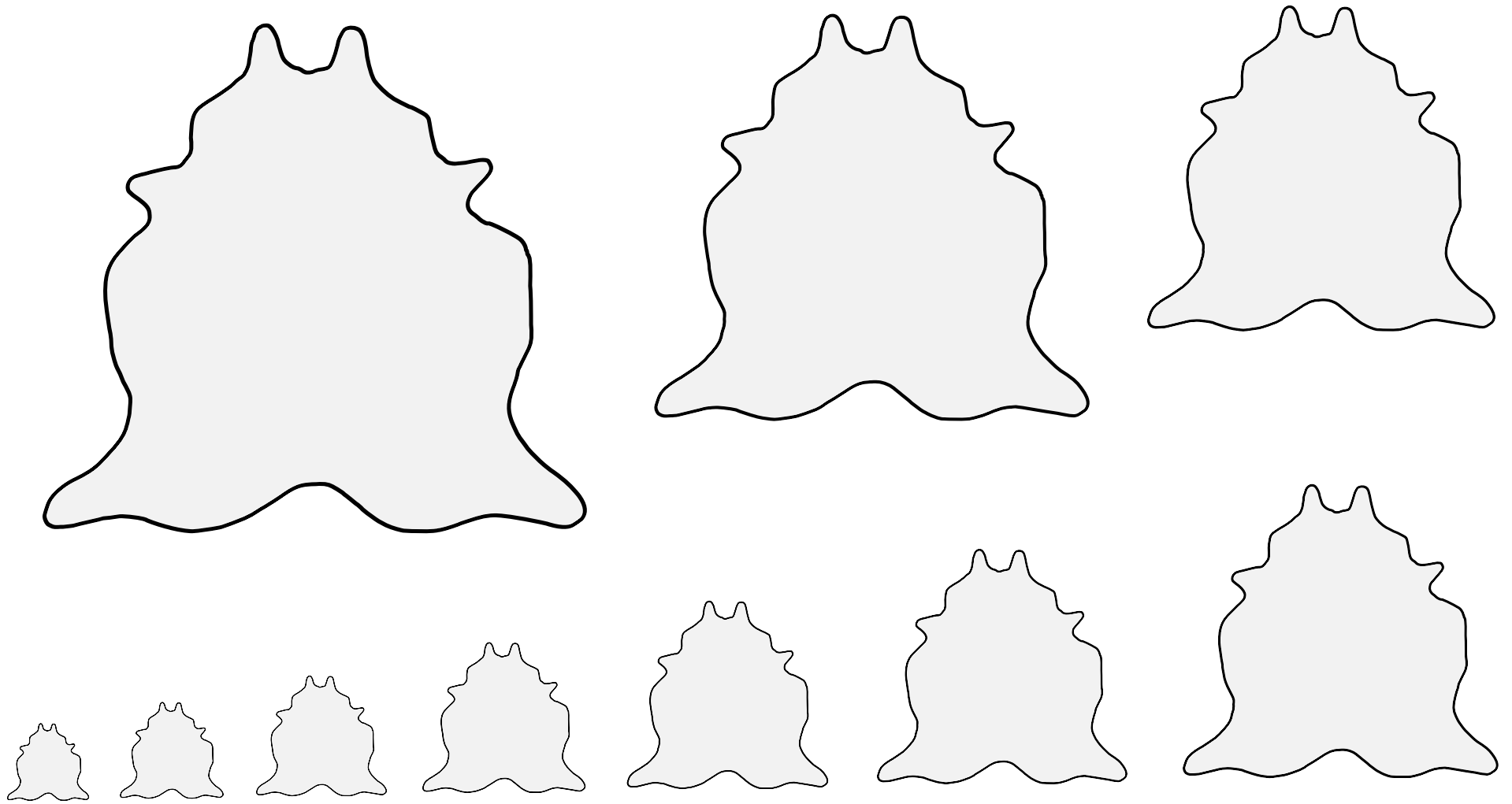

The skin of a cow, removed in a single piece for use in manufacturing leather or parchment.
Default orientation: head to chief. No proper coloration.

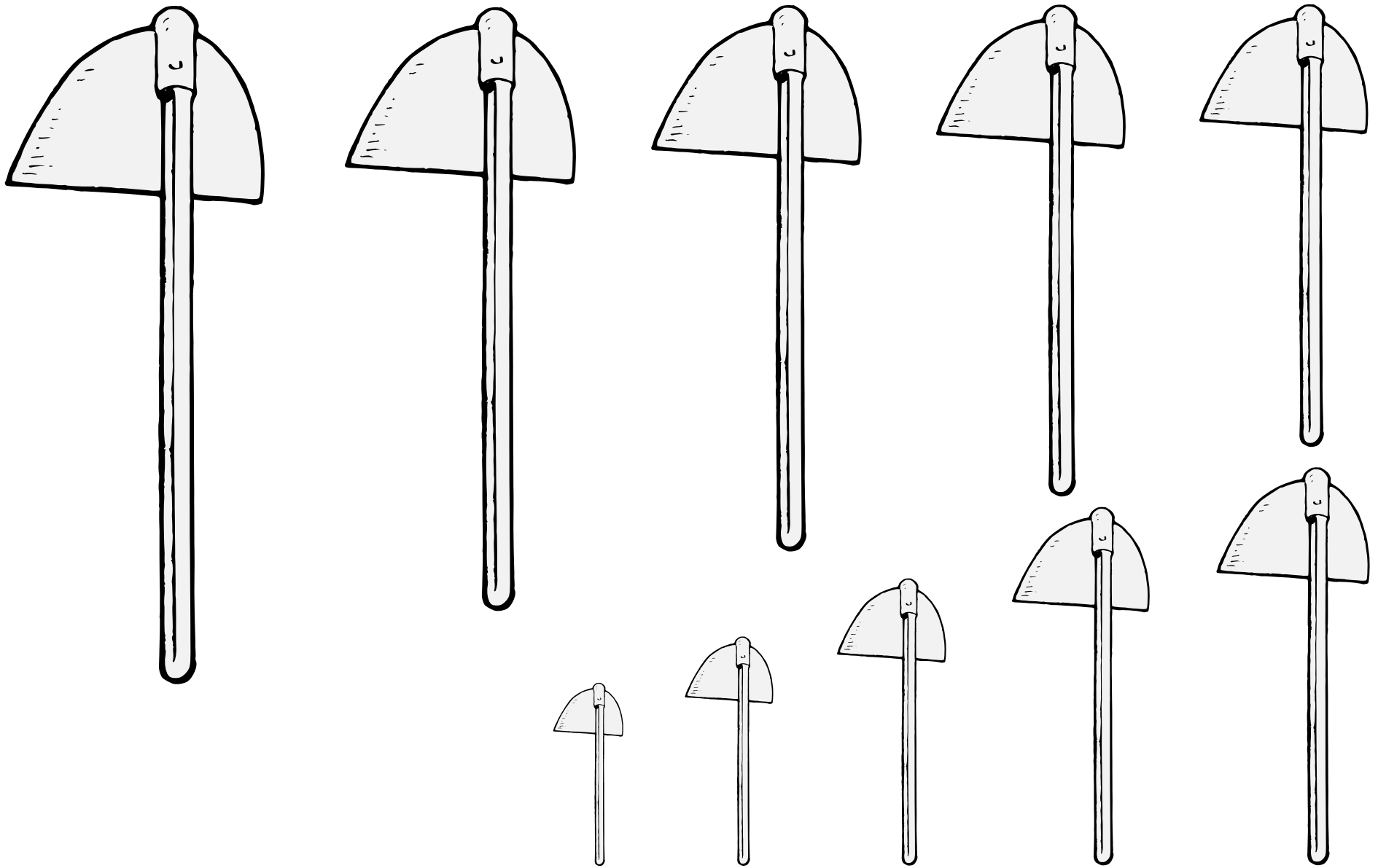

A farming implement used to break up grass and earth before sowing crops.

Default orientation: blade to chief, as of the March 2021 Cover Letter. No proper coloration.

Source: Wappenbuch des Landkreises Hannover. Artist: Gustav Völker.

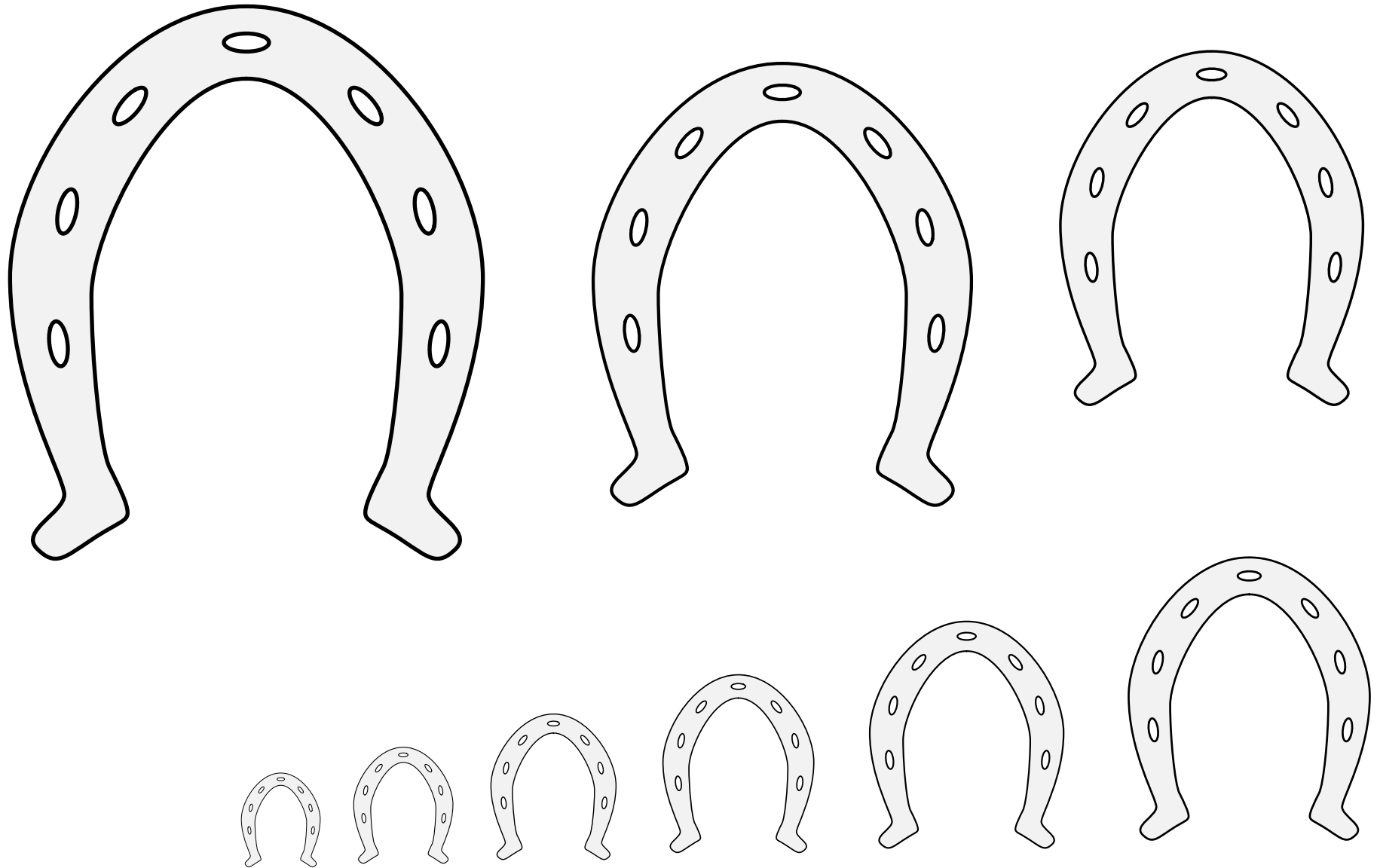

A curved piece of metal attached to a horse's hooves to protect them.

Default orientation: opening to base. No proper coloration.

Source: Pennsic Traceable Art. Artist unknown.

Adapted by Mathghamhain Ua Ruadháin.

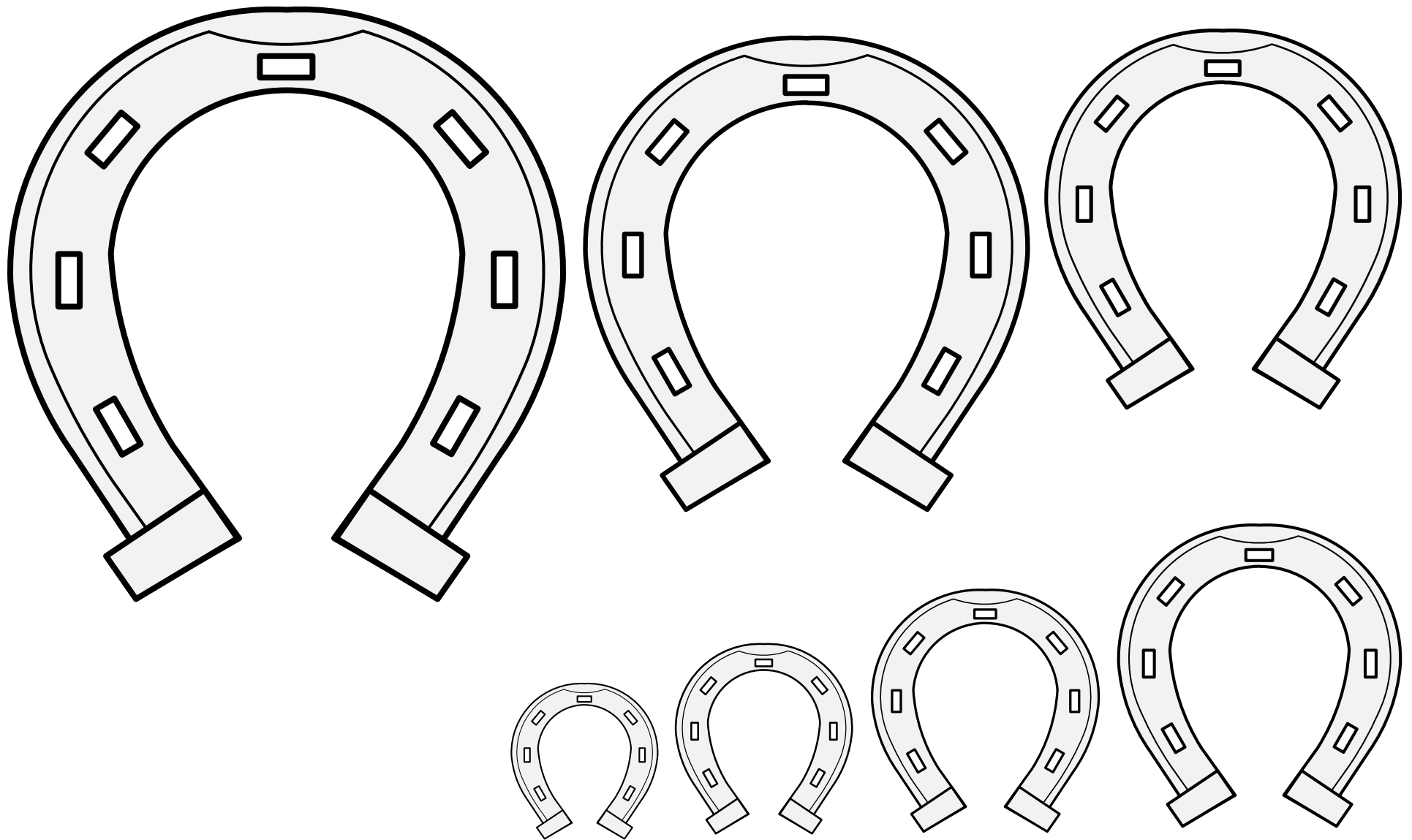

A curved piece of metal attached to a horse's hooves to protect them.

Default orientation: opening to base. No proper coloration.

Source: Viking Answer Lady SVG Images For Heraldists. Artist: Gunnvör silfrhárr.

Horseshoe (2) 19.75

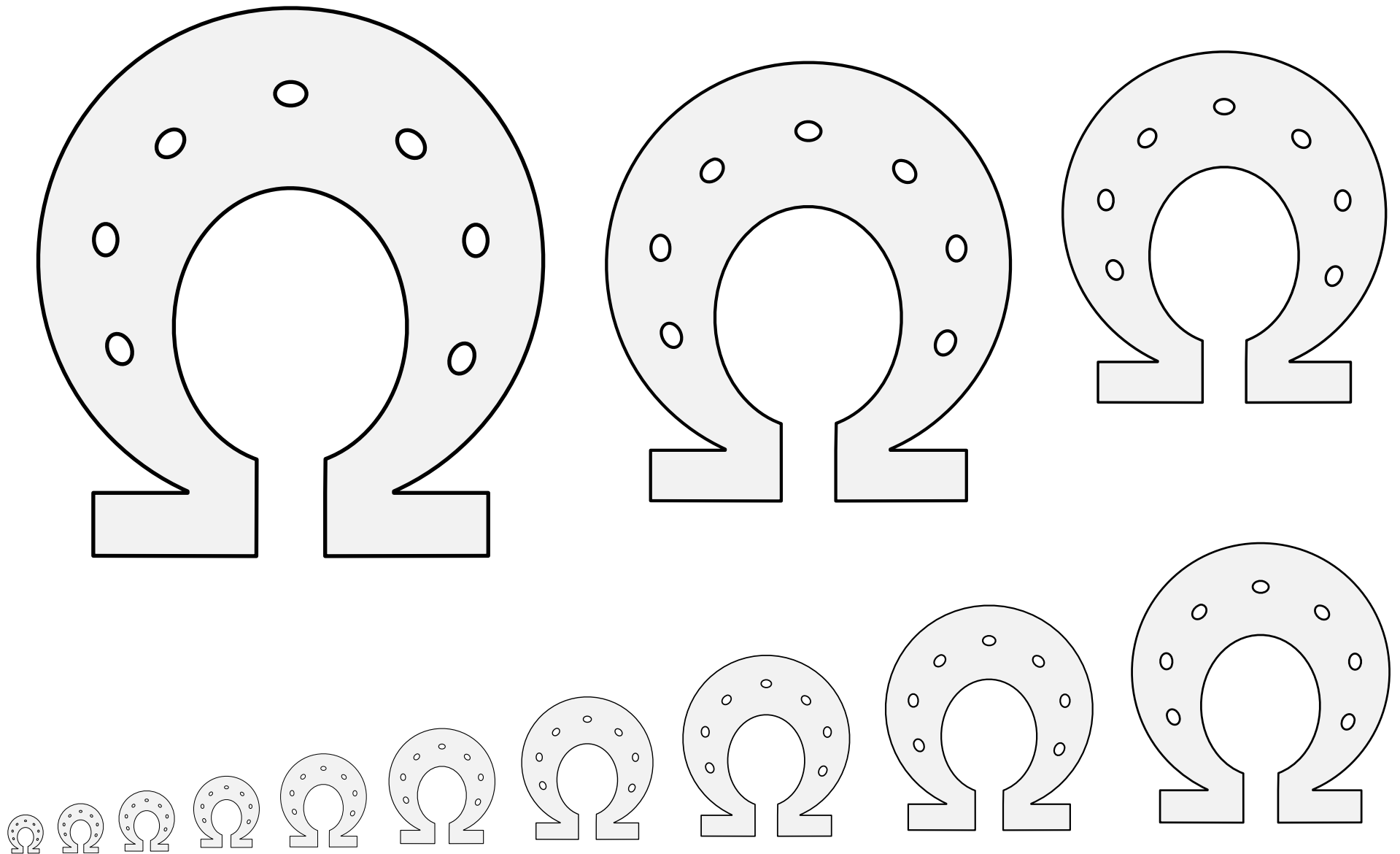

A curved piece of metal attached to a horse's hooves to protect them.

Default orientation: opening to base. No proper coloration.

Source: Guillim's Display of Heraldry. Artist unknown. Adapted by Mathghamhain Ua Ruadháin.

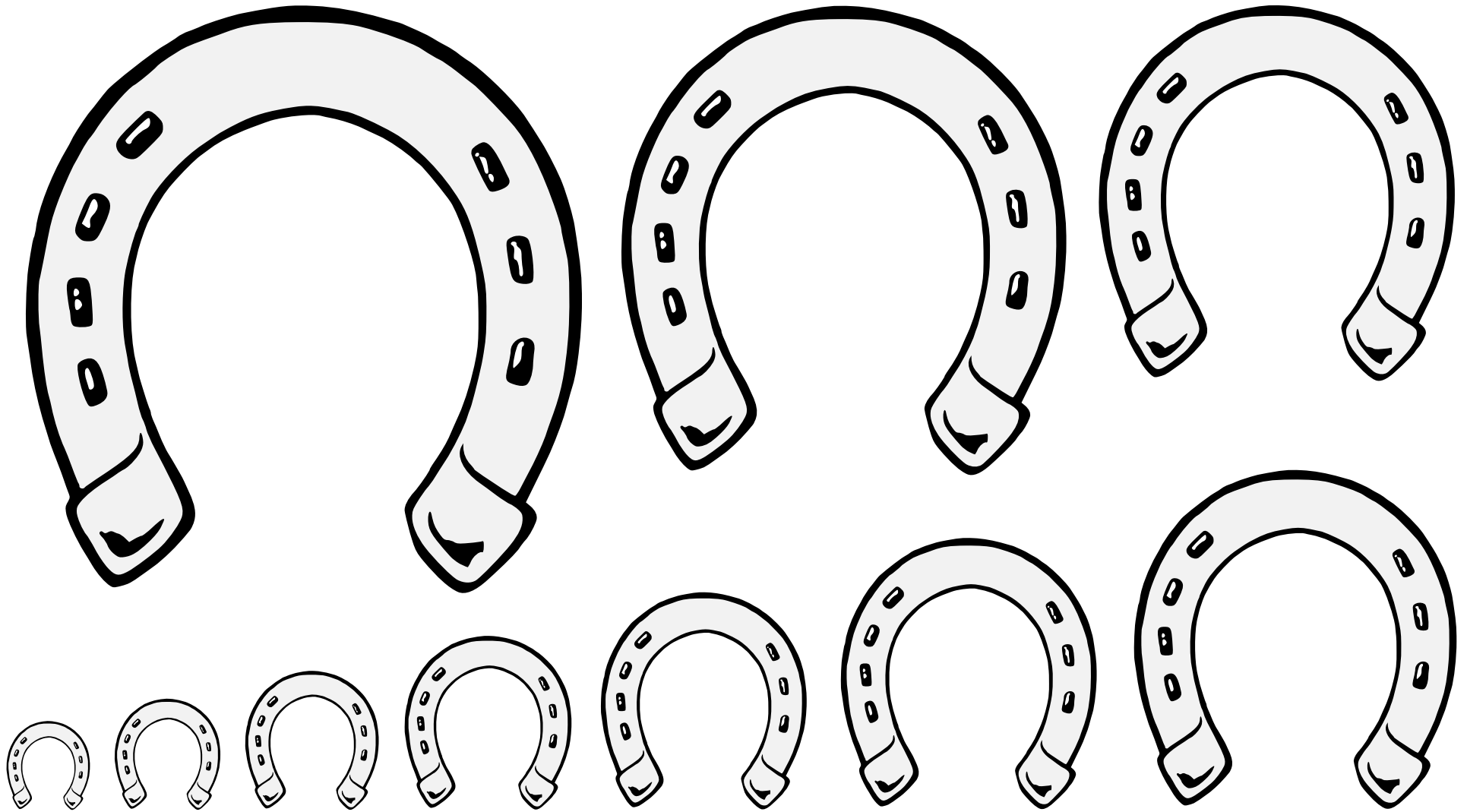

A curved piece of metal attached to a horse's hooves to protect them.

Default orientation: opening to base. No proper coloration.

Source: Some Feudal Lords and Their Seals. Artist unknown.

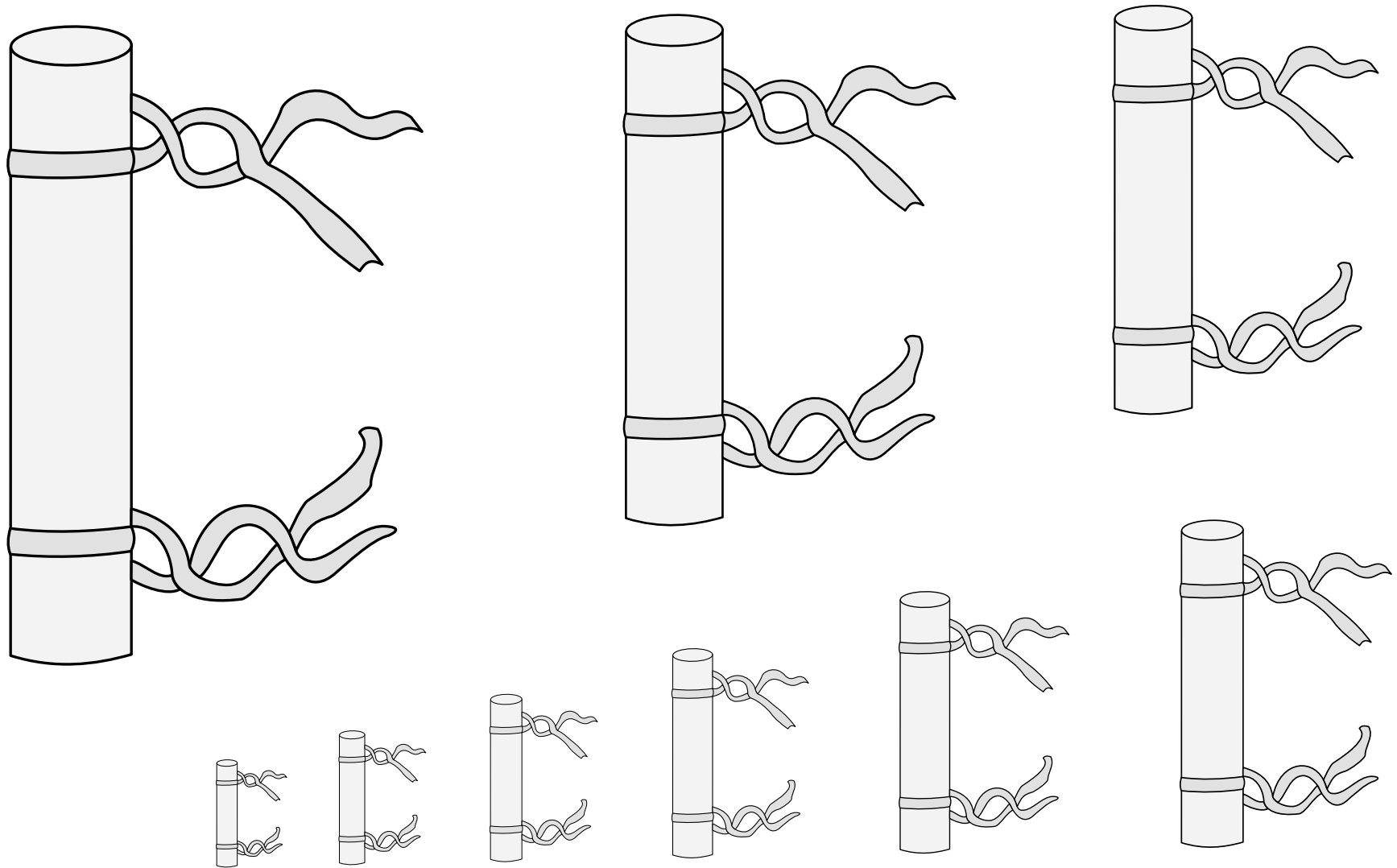

A device which may be attached to two working dogs to manage them as a pair.

Default orientation unknown. No proper coloration.

Source: Armorial Français et Plus Particulièrement Poitevin.
Artist unknown. (Folio 81r.) Adapted by Iago ab Adam.

Hound Couple Palewise 19.78

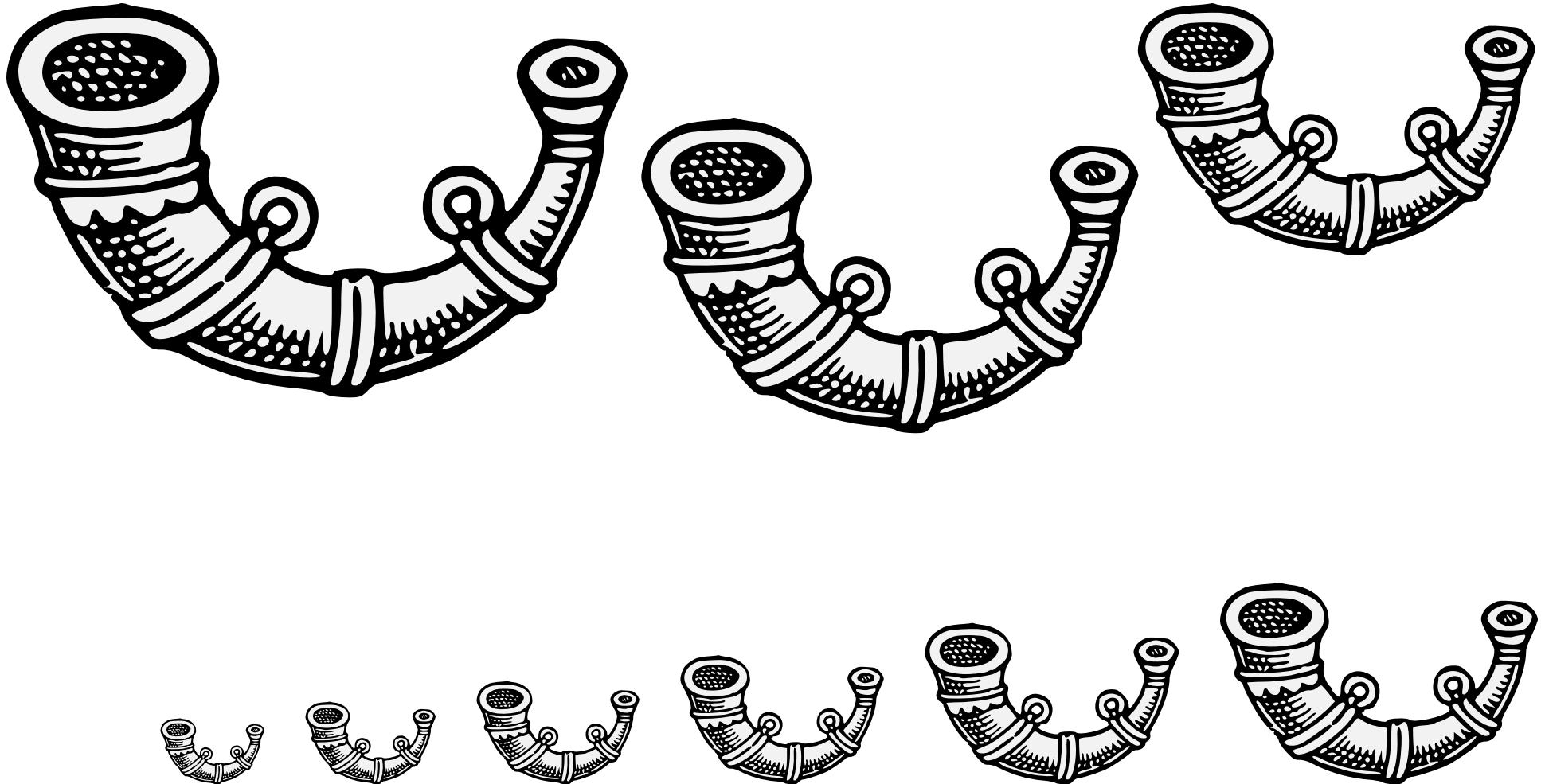

An animal's horn, adapted to make a loud sound.

May be pictured hanging from a loop of rope, or with the encircling bands tinctured differently.

Default orientation: curved to base, opening to dexter. No proper coloration.

Source: A Complete Guide to Heraldry. Artist: Graham Johnston.

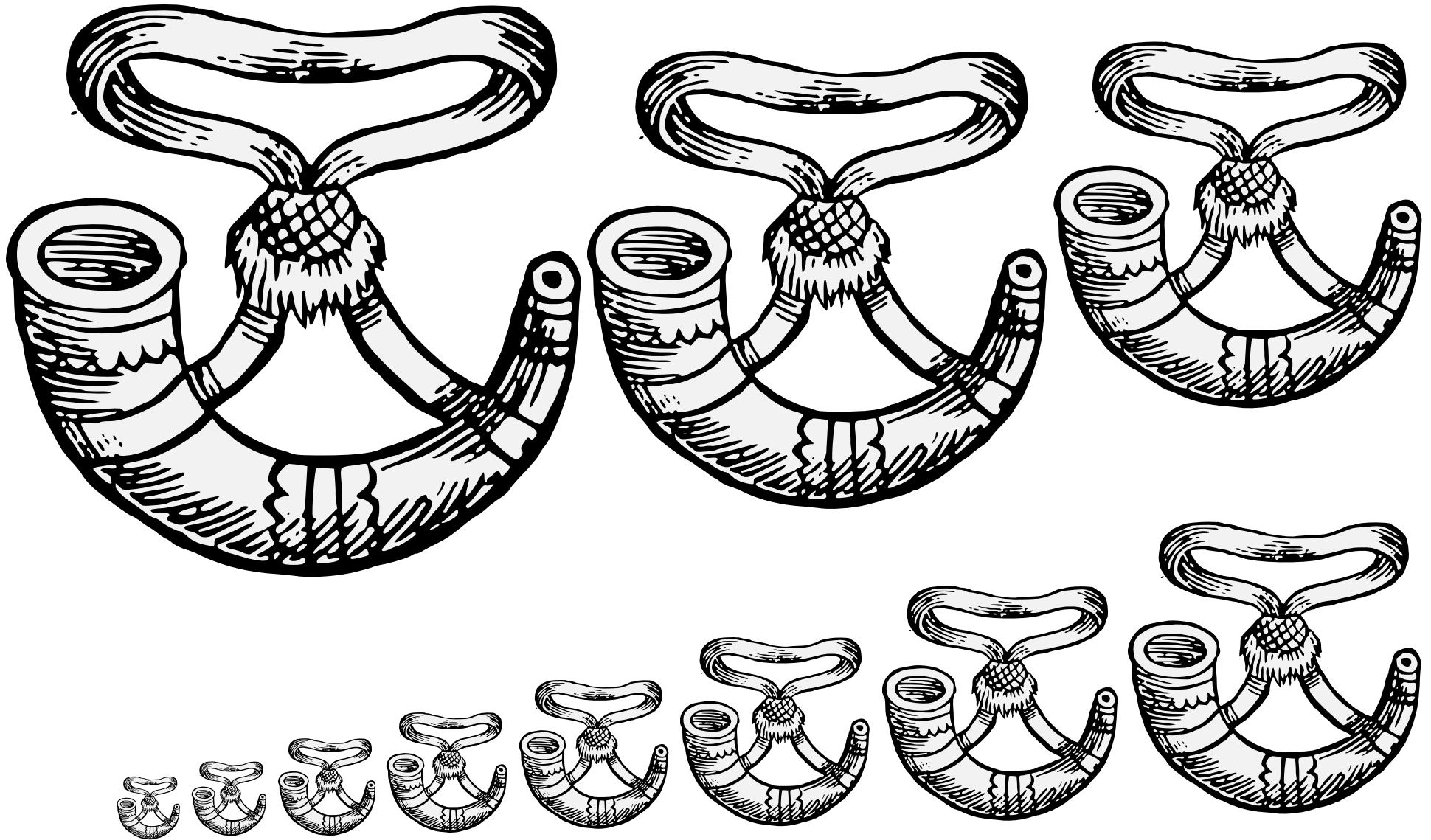

An animal's horn, adapted to make a loud sound.

May be pictured hanging from a loop of rope, or with the encircling bands tintured differently.

Default orientation: curved to base, opening to dexter. No proper coloration.

Source: Guillim's Display of Heraldry. Artist unknown.

Hunting Horn (2) 19.80

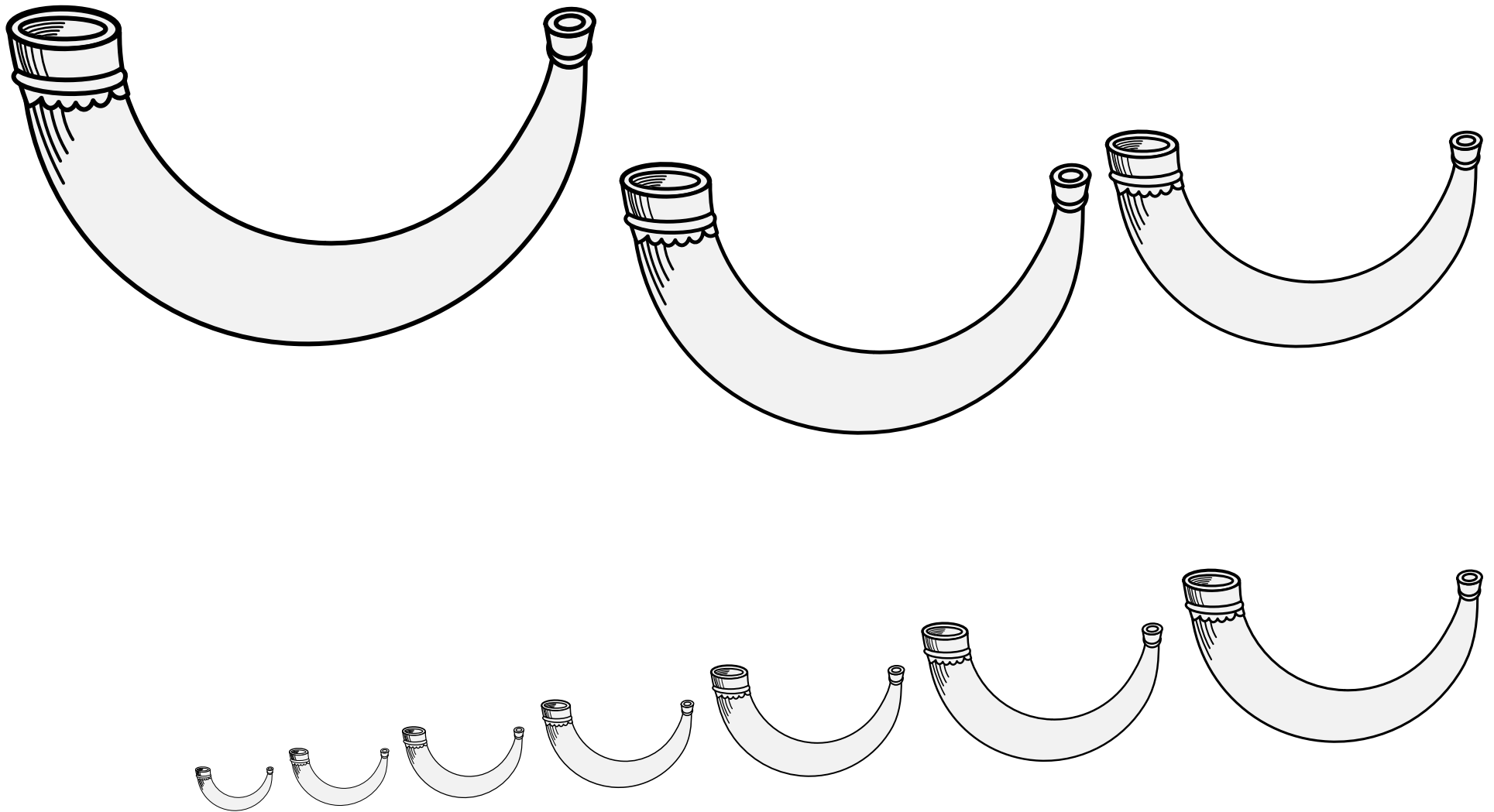

An animal's horn, adapted to make a loud sound.

May be pictured hanging from a loop of rope, or with the encircling bands tintured differently.

Default orientation: curved to base, opening to dexter. No proper coloration.

Source: Viking Answer Lady SVG Images
For Heraldists. Artist: Gunnvör silfrhárr.

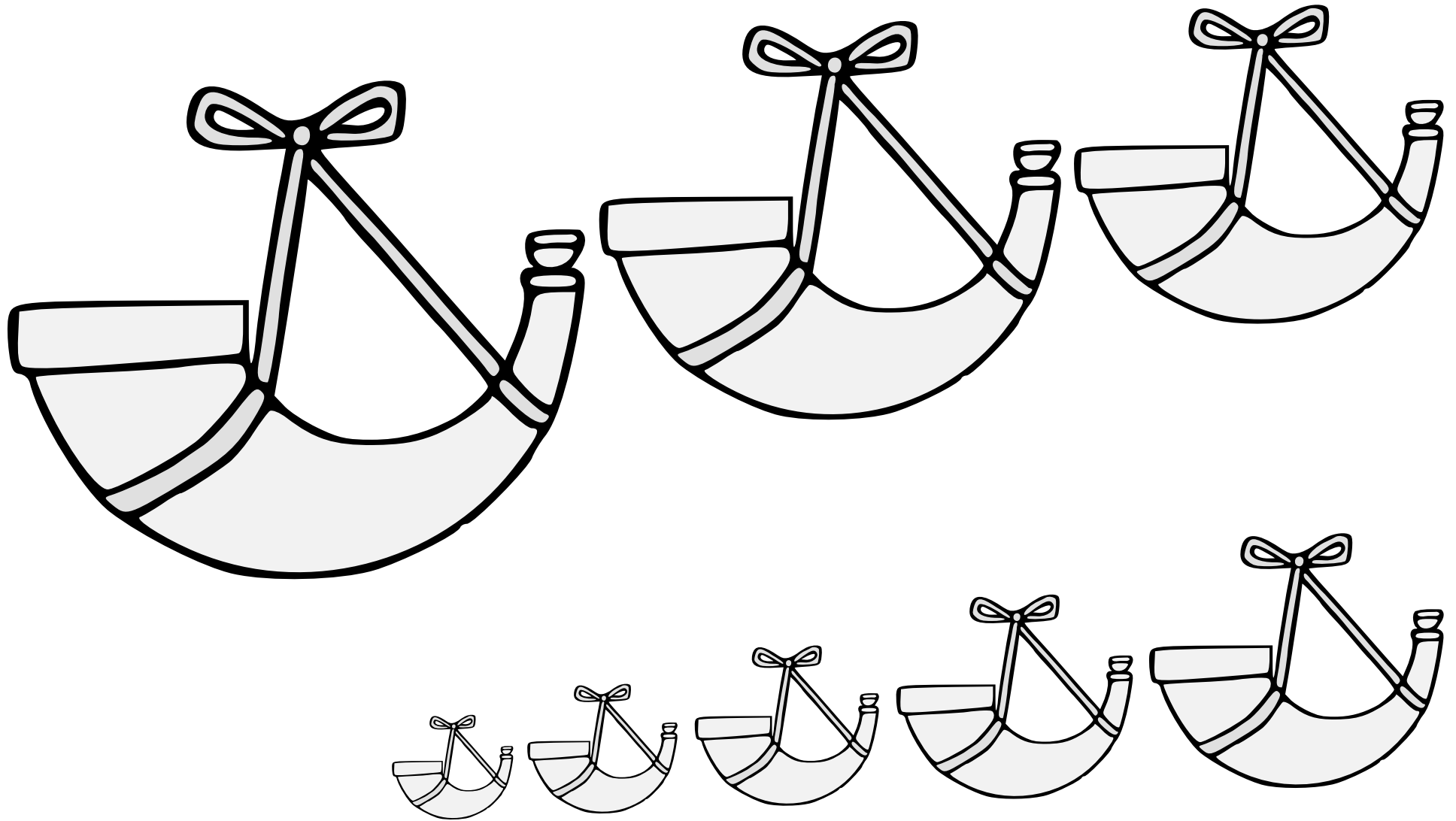

An animal's horn, adapted to make a loud sound.

May be pictured hanging from a loop of rope, or with the encircling bands tintured differently.

Default orientation: curved to base, opening to dexter. No proper coloration.

Source: Pennsic Traceable Art. Artist: Roana d'Evreux.

Hunting Horn (4) 19.82

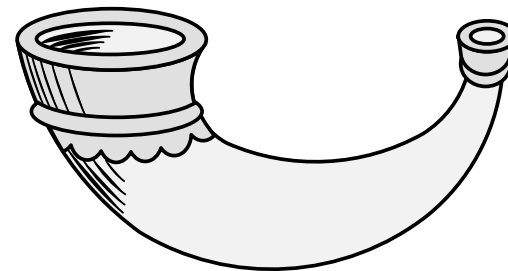
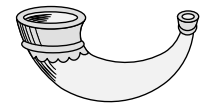
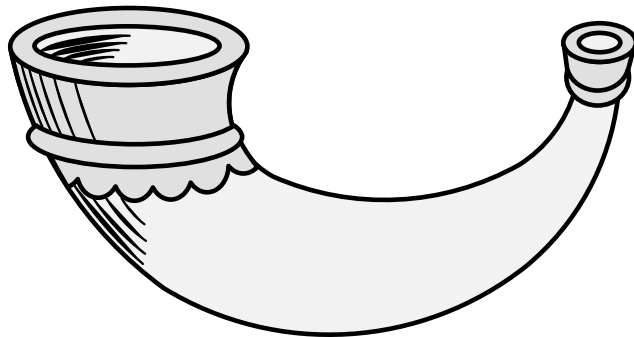
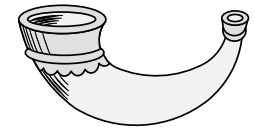
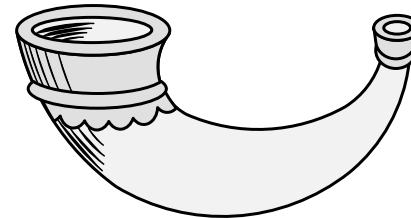
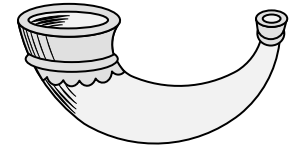
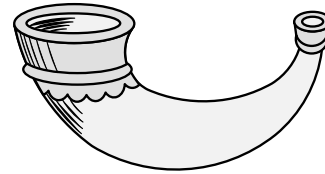
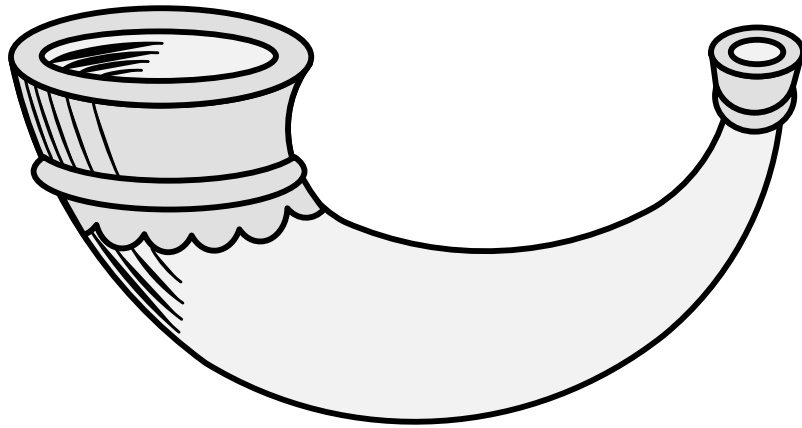

An animal's horn, adapted to make a loud sound.

May be pictured hanging from a loop of rope, or with the encircling bands tintured differently.

Default orientation: curved to base, opening to dexter. No proper coloration.

Source: Viking Answer Lady SVG Images For Heraldists. Artist: Gunnvôr silfrárr.

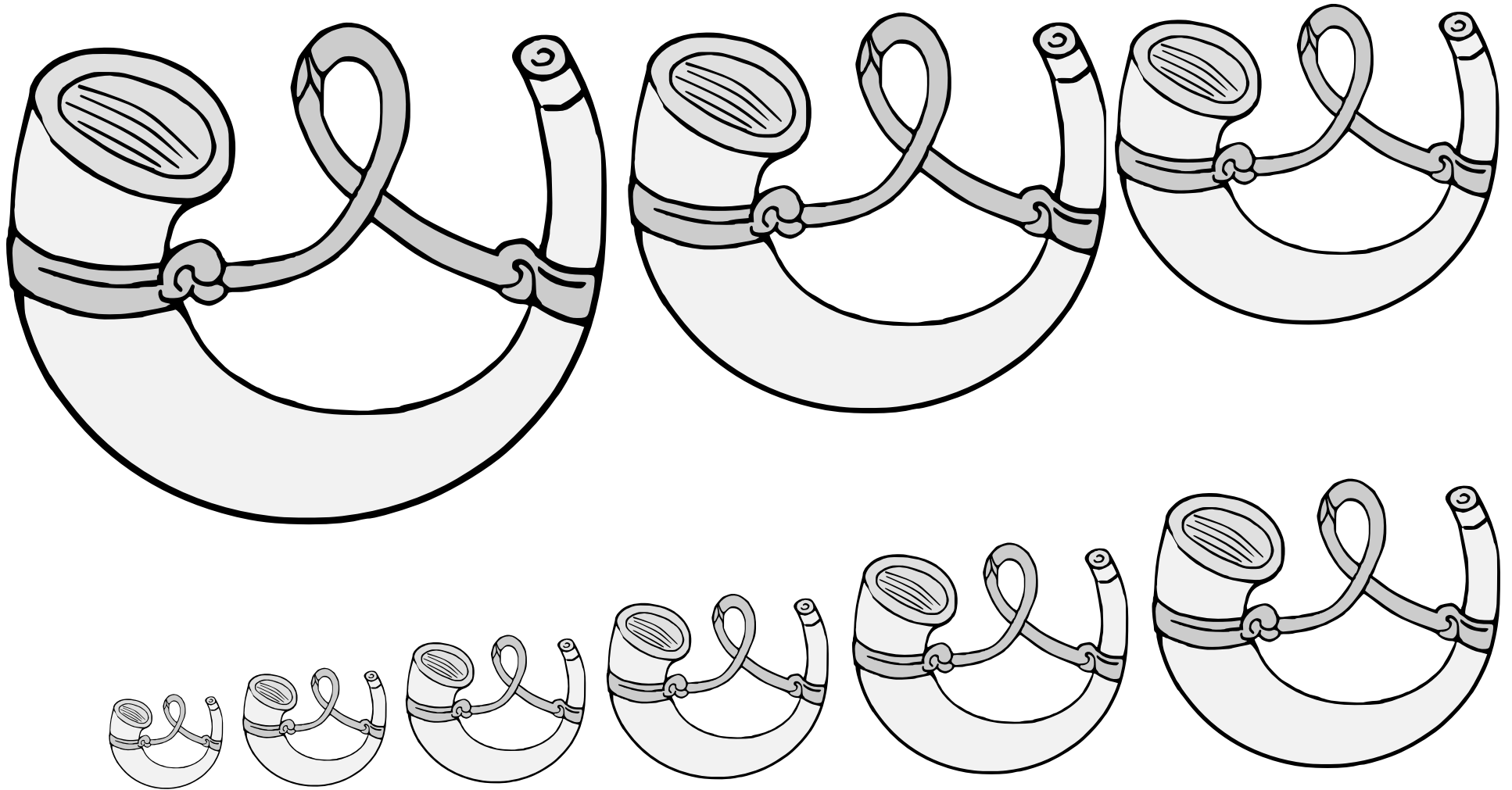

An animal's horn, adapted to make a loud sound.

May be pictured hanging from a loop of rope, or with the encircling bands tintured differently.

Default orientation: curved to base, opening to dexter. No proper coloration.

Source: Wappenbuch der Arlberg-Bruderschaft. Artist: Vigil Raber.

Adapted by Jessimond of Emerickeskepe.

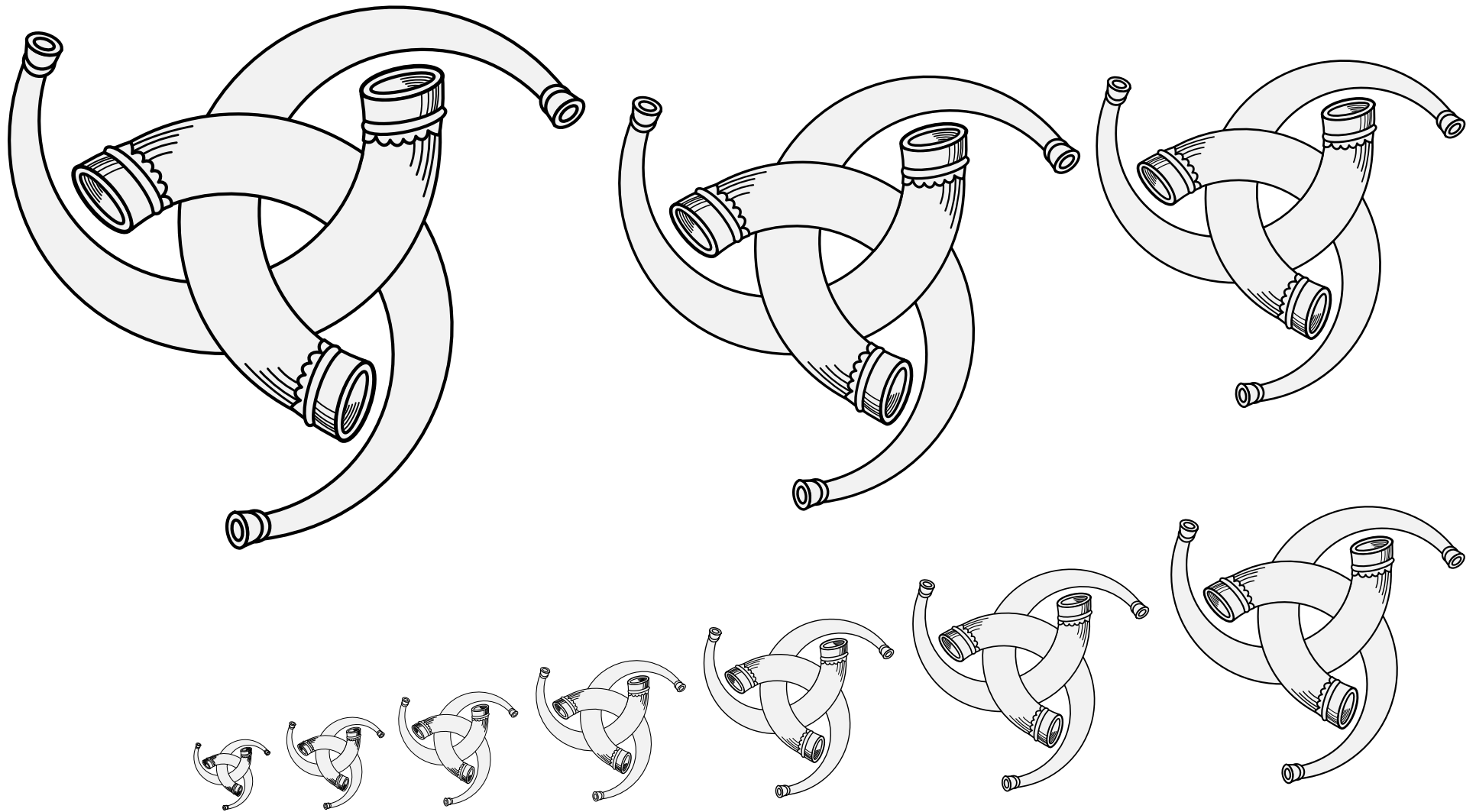

An animal's horn, adapted to make a loud sound.

May be pictured hanging from a loop of rope, or with the encircling bands tinctured differently.

Default orientation: curved to base, opening to dexter. No proper coloration.

Source: Viking Answer Lady SVG Images
For Heraldry. Artist: Gunnvör silfrahárr.

Hunting Horns, Three, Interlaced 19.85

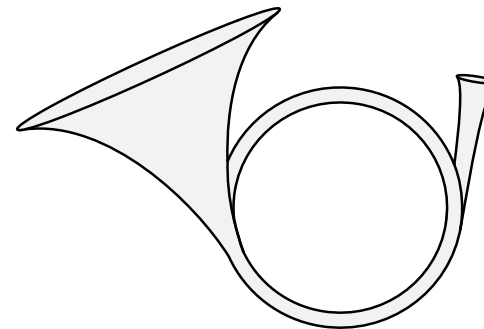
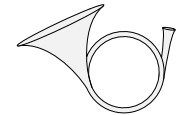
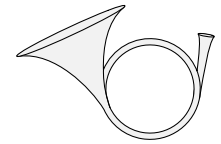
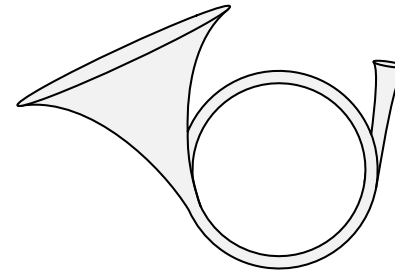
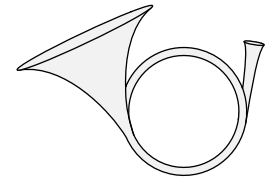
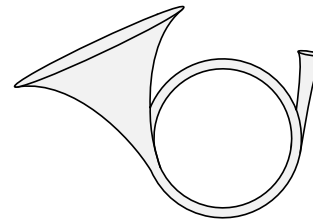
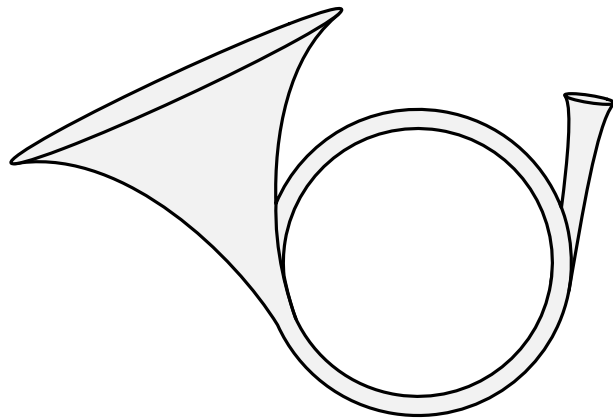
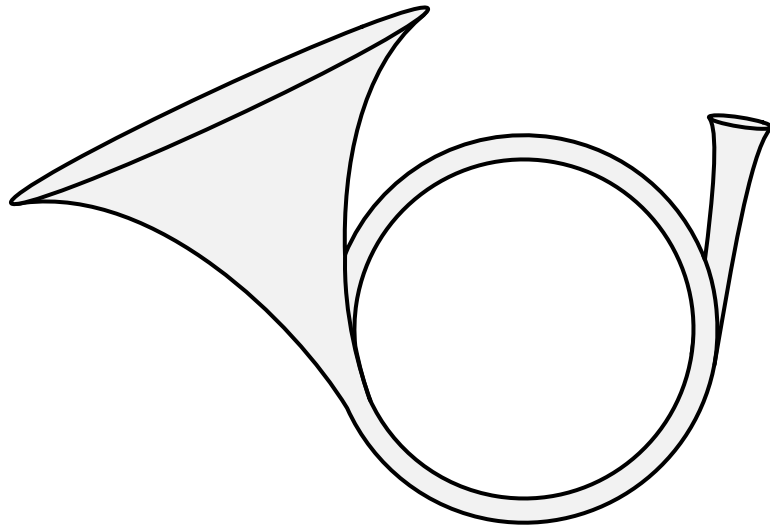

A wind instrument. Similar to a straight trumpet, but coiled.
Default orientation: bell to chief. No proper coloration.

Hunting Horn, Spiral 19.86

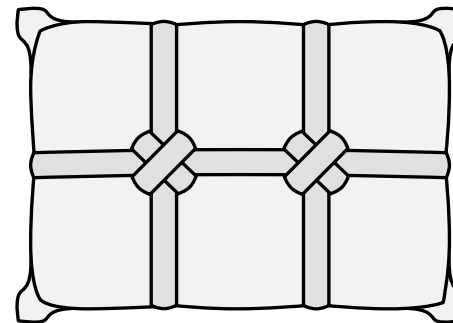
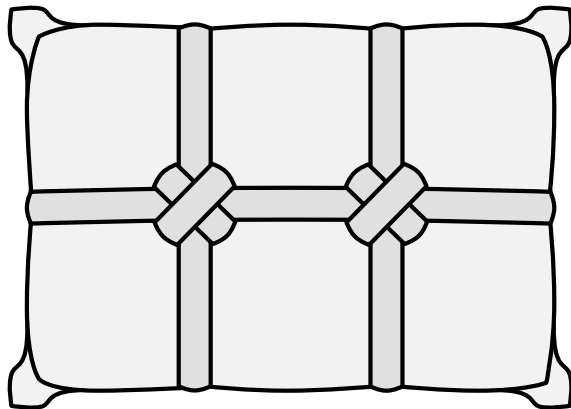
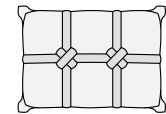
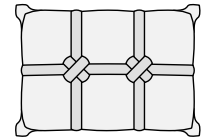
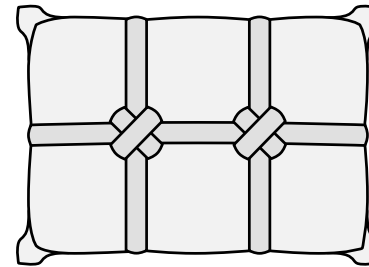
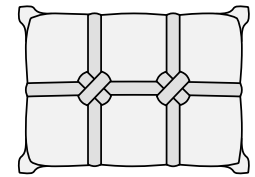
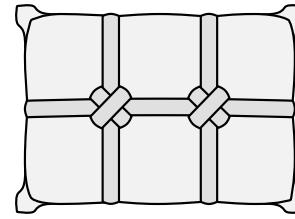
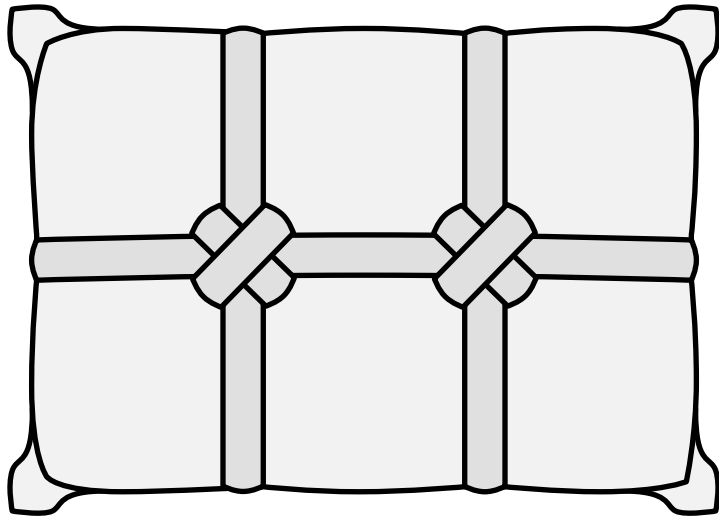

A bag of madder roots tied up with rope.

Default orientation: fesswise. No proper coloration.

Adapted from depictions of the arms of the Dyers' Company.

Madder, Bag of (1) 19.87

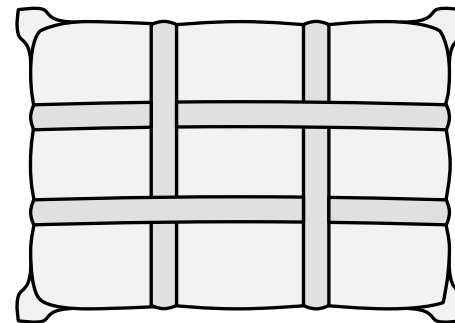
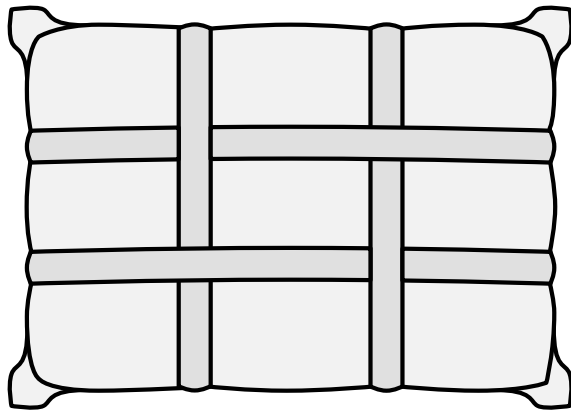
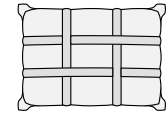
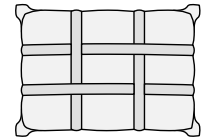
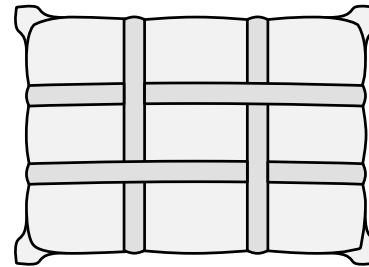
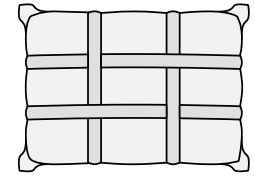
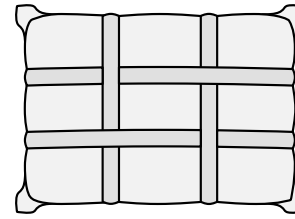
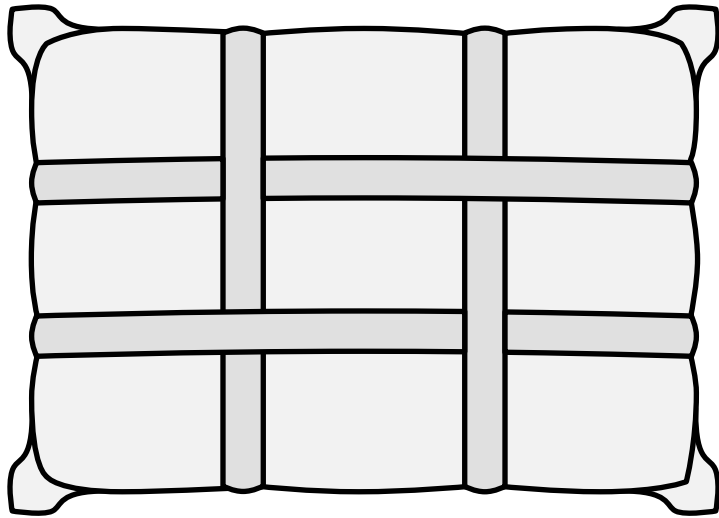

A bag of madder roots tied up with rope.

Default orientation: fesswise. No proper coloration.

Adapted from depictions of the arms of the Dyers' Company.

Madder, Bag of (2) 19.88

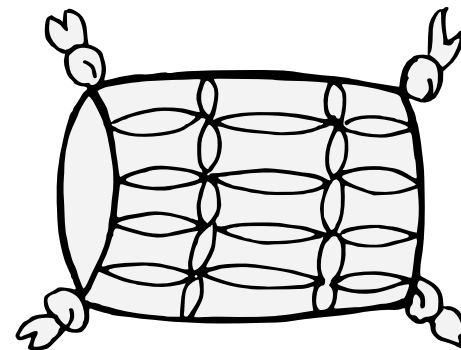
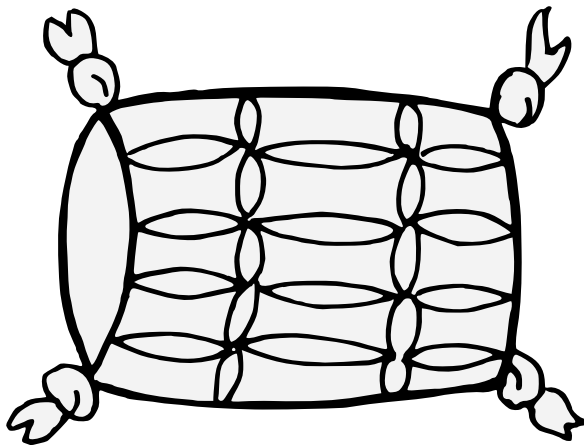
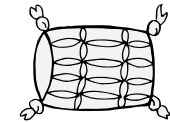
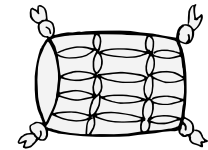
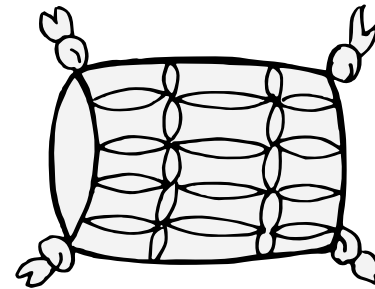
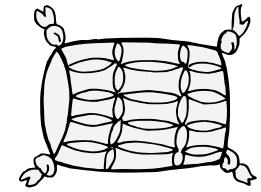
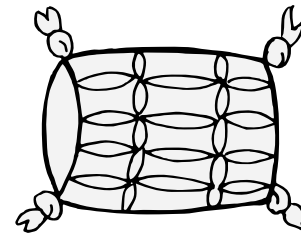
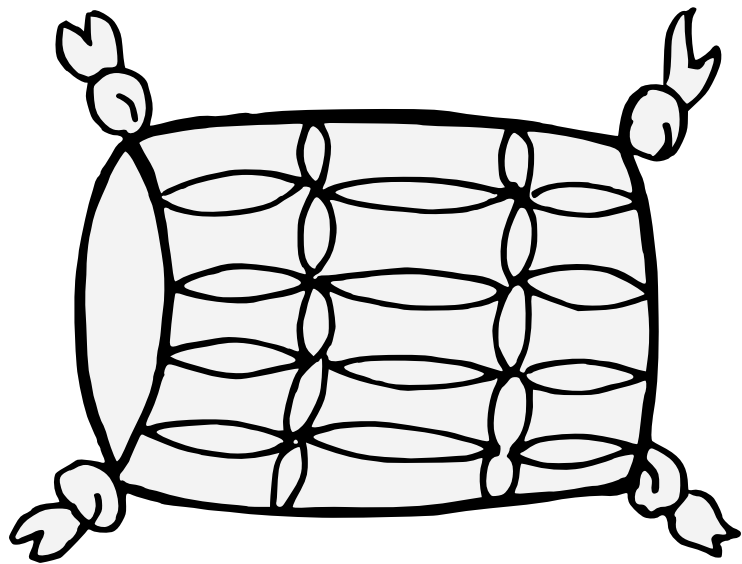

A bag of madder roots tied up with rope.

Default orientation: fesswise. No proper coloration.

Source: The Armes of All the Cheife Corporatons.

Adapted by Iago ab Adam.

(From the arms of the Dyers' Company.)

Madder, Bag of (3) 19.89

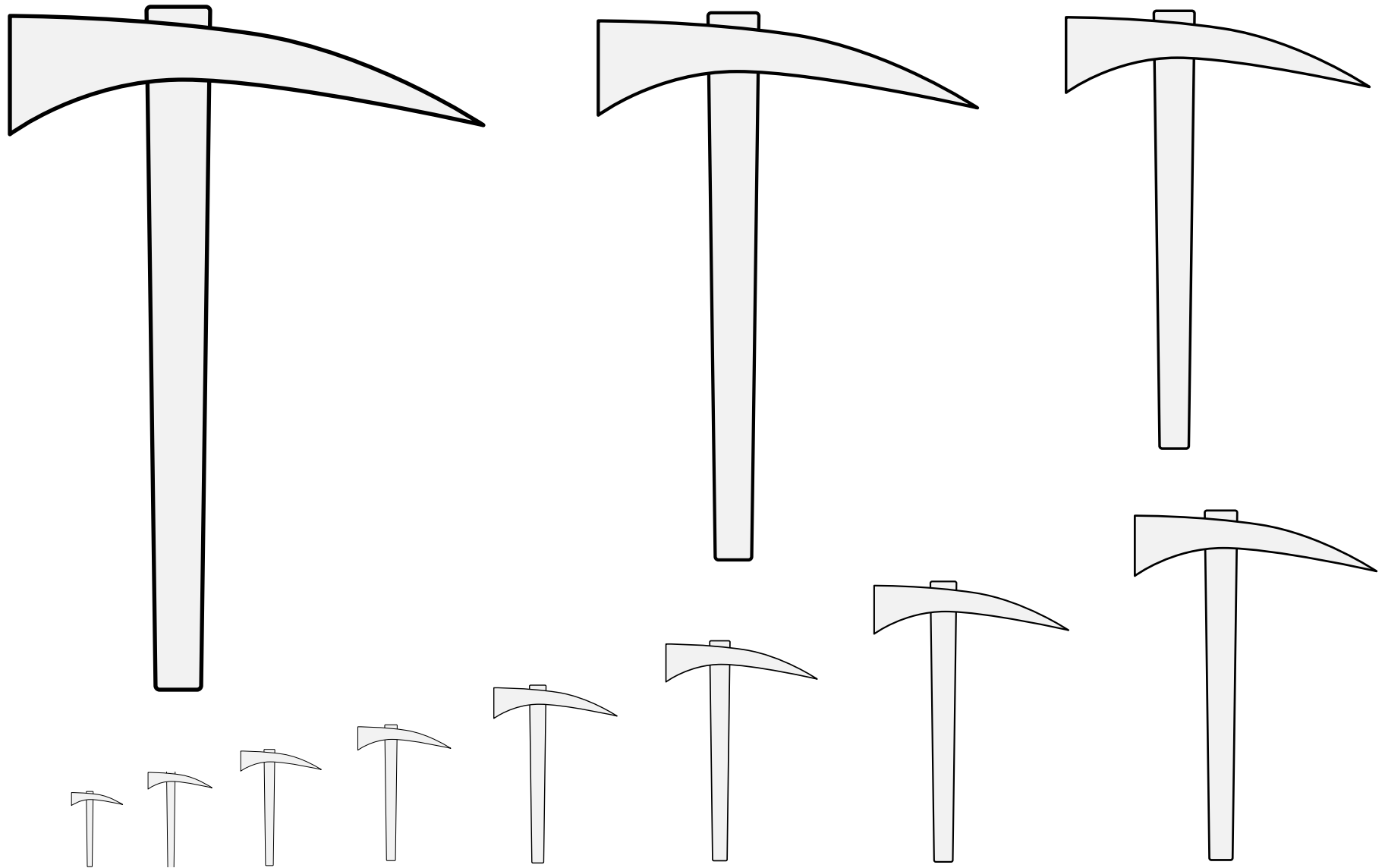

A specialized farming implement used to break up grass and earth before sowing crops.

No default orientation. No proper coloration.

Source: Pennsic Heralds' Point Artists. Artist unknown. Adapted by Mathghamhain Ua Ruadháin.

Mattock 19.90

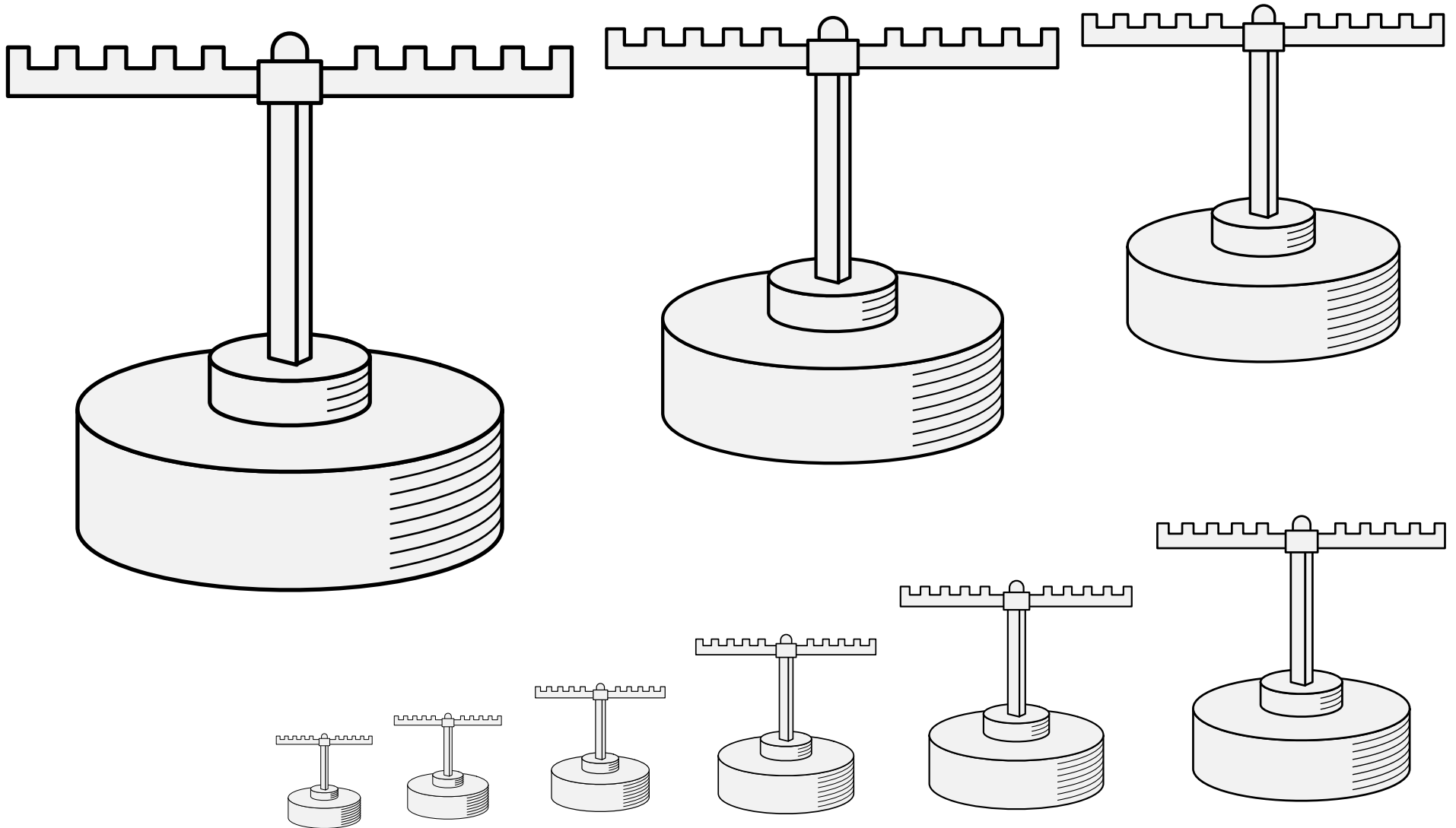

A grinding stone attached to a wooden pole that allows it to be turned, grinding grain to flour.

Default orientation: horizontal stone with axle to chief. Proper coloration: gray or argent stone.

Source: Siebmacher's Wappenbuch of 1605. Artist: Johann Siebmacher.
(Arms of Uhrmuhl, page 98.)

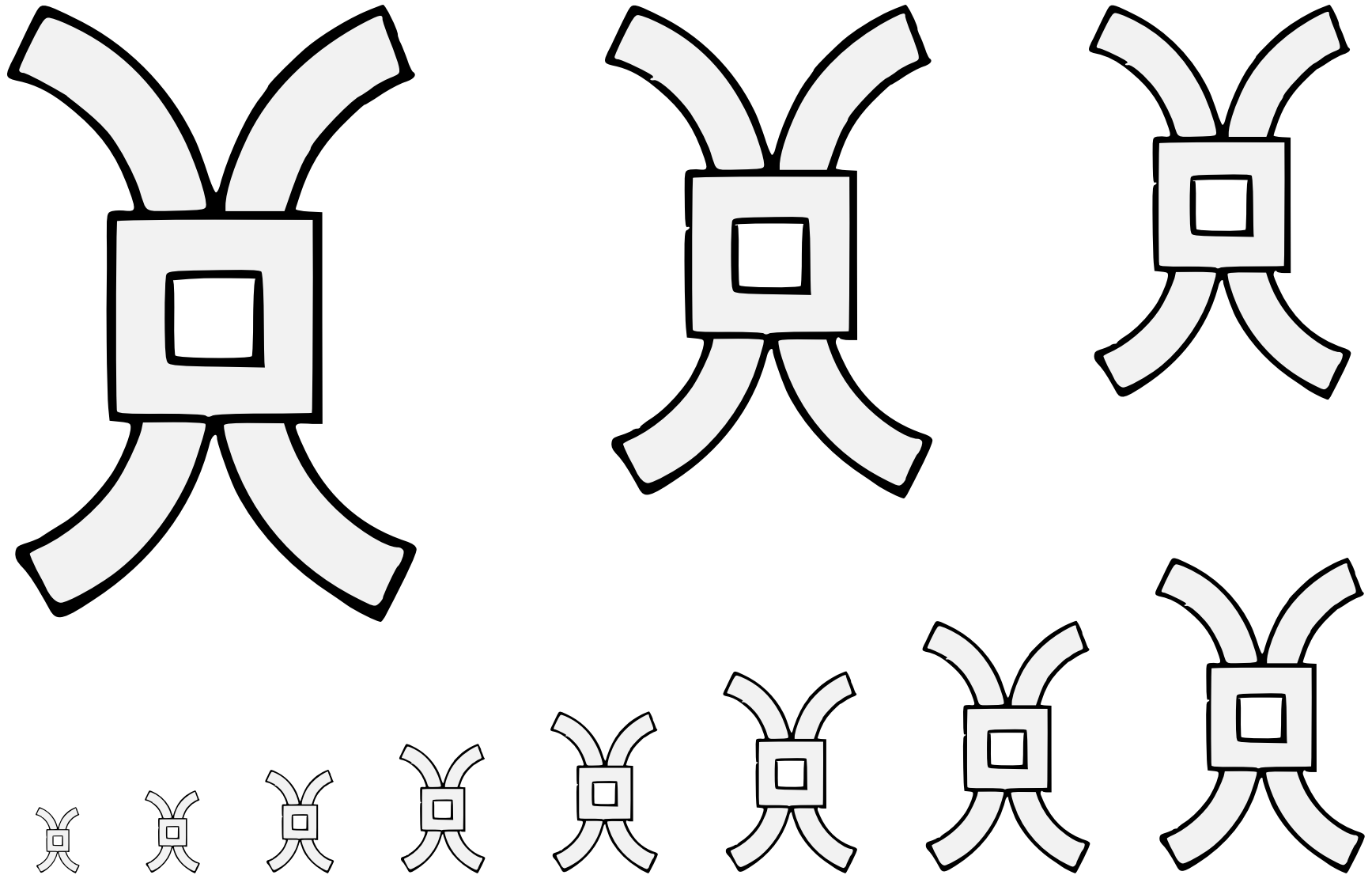

A fastener plate for a millstone.

Default orientation: palewise. No proper coloration.

Source: A Complete Guide to Heraldry. Artist: Graham Johnston.

Millrind (1) 19.92

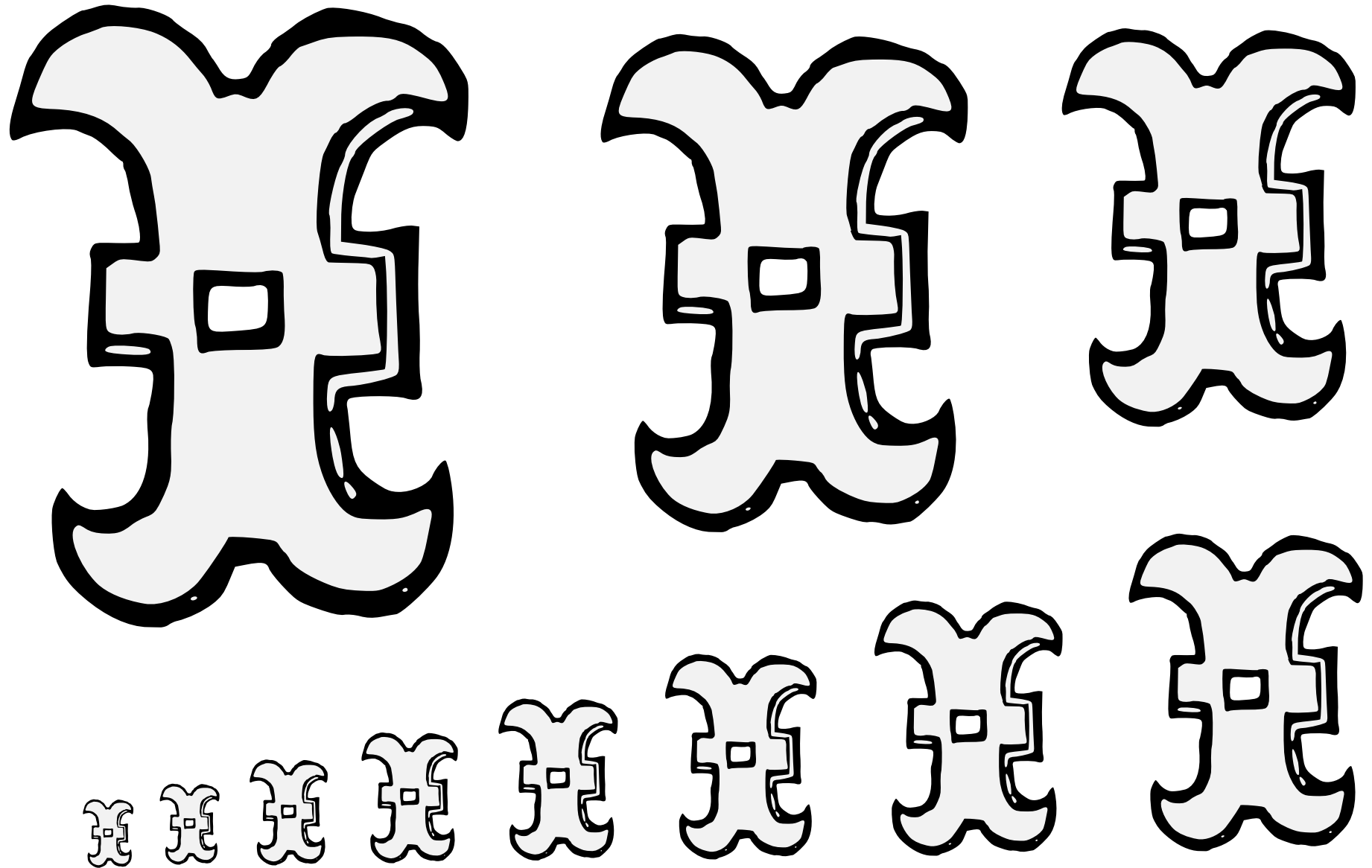

A fastener plate for a millstone.

Default orientation: palewise. No proper coloration.

Source: Guillim's Display of Heraldry. Artist unknown.

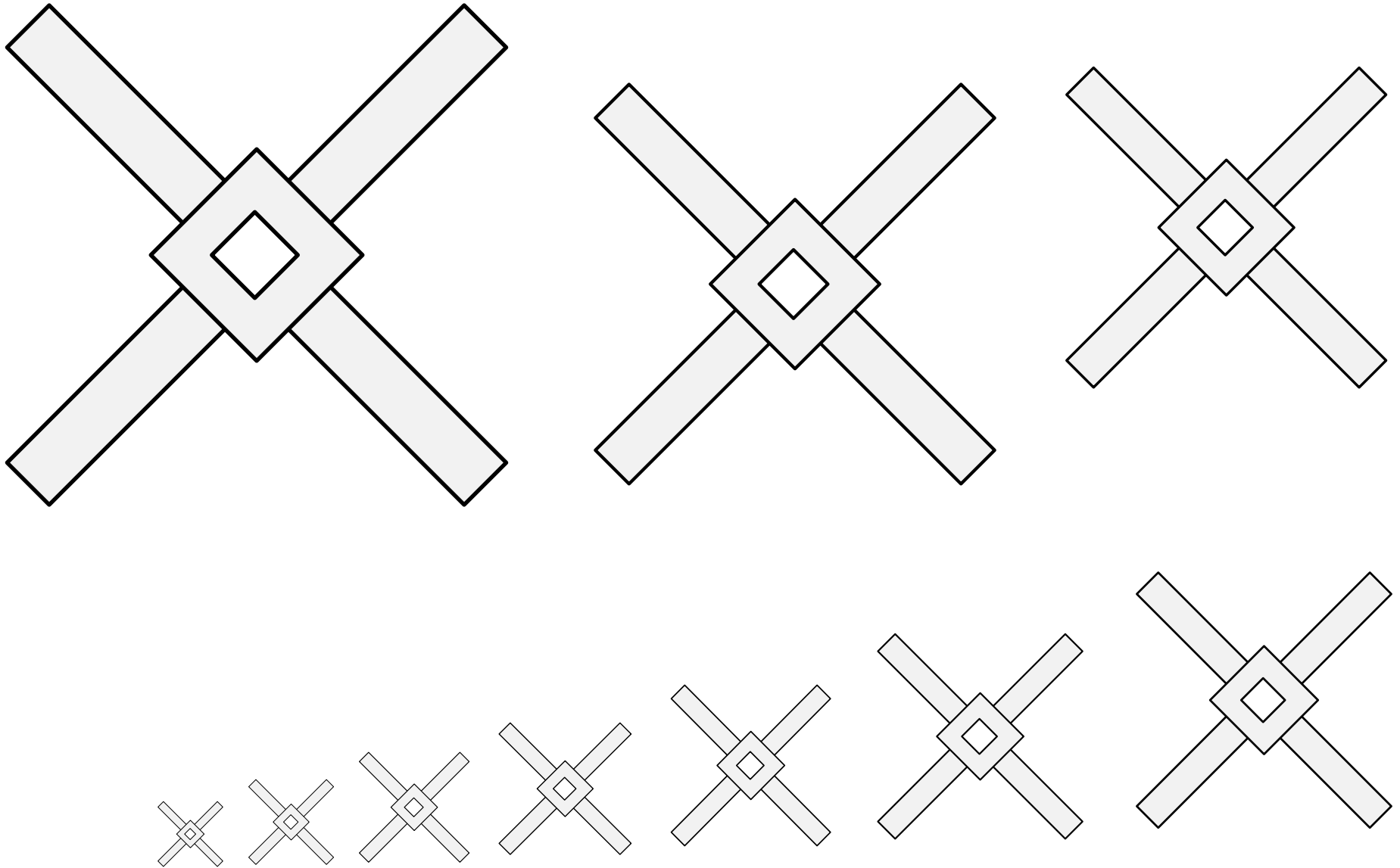

A fastener plate for a millstone.

Default orientation: saltirewise. No proper coloration.

Source: Bergshammar Armorial. Artist unknown. Adapted by Mathghamhain Ua Ruadháin.

Millrind (3) 19.94

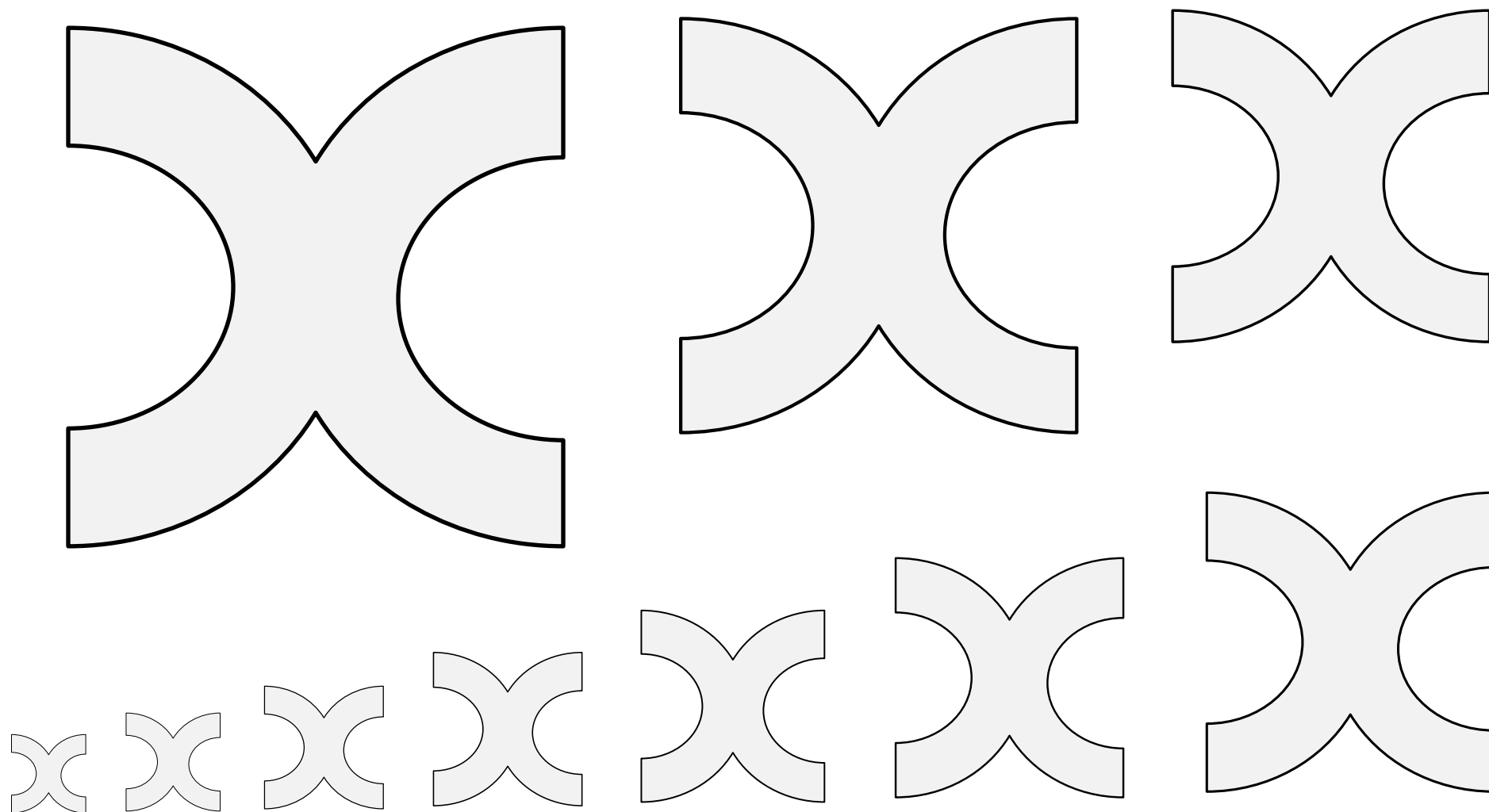

A fastener plate for a millstone.

Default orientation: saltirewise. No proper coloration.

Source: Jacques Prévert Ms. 57. Artist unknown. (Page 12.)

Millrind (4) 19.95

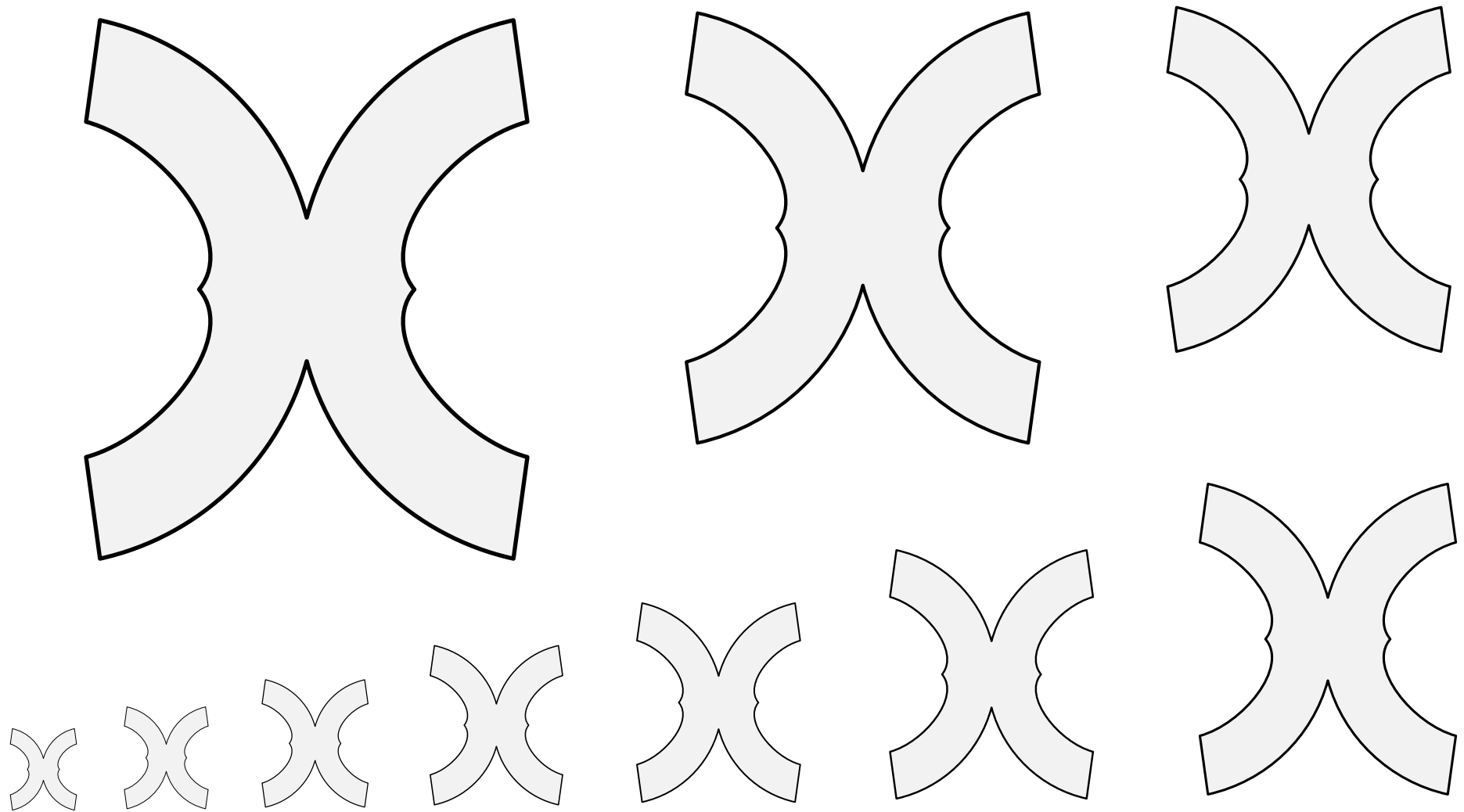

A fastener plate for a millstone.

Default orientation: saltirewise. No proper coloration.

Source: English Arms A. Artist unknown. (Page 159.)

Millrind (5) 19.96

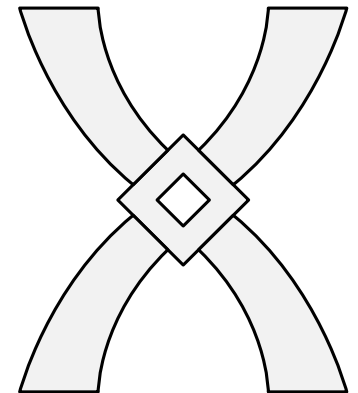
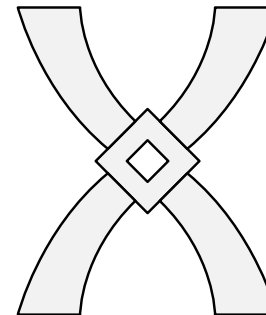
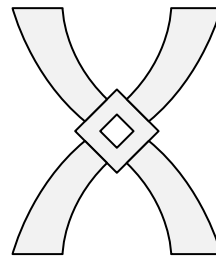
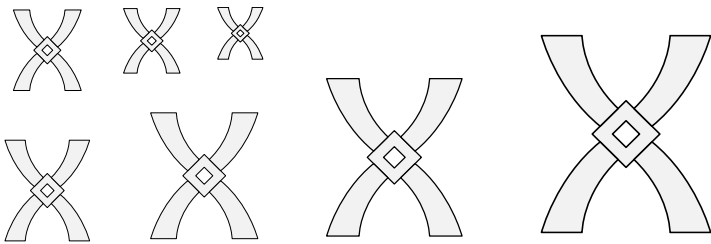
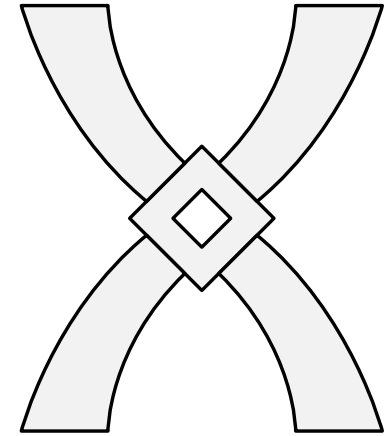
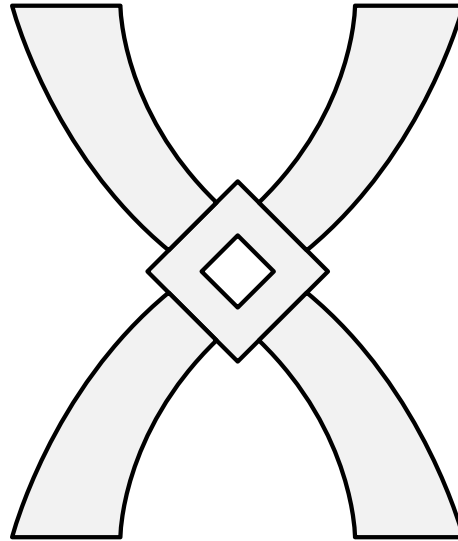
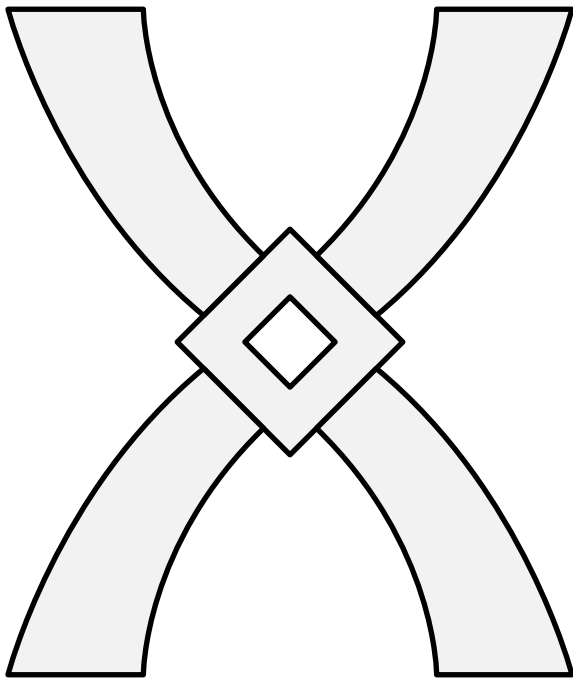

A fastener plate for a millstone.
Default orientation: saltirewise. No proper coloration.

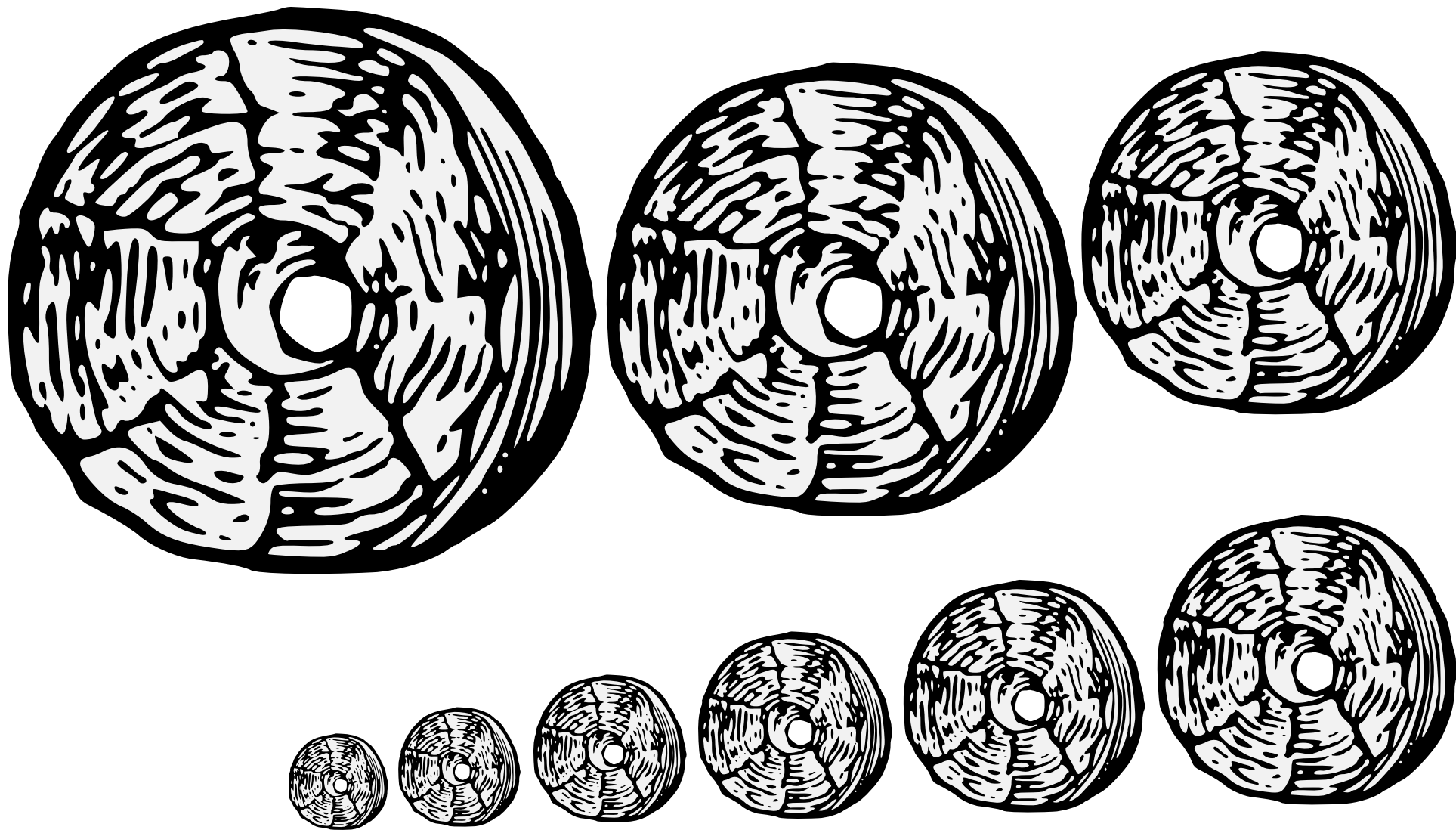

A circular grinding wheel.

Default orientation: affronty. No proper coloration.

Source: Guillim's Display of Heraldry. Artist unknown.

Millstone (1) 19.98

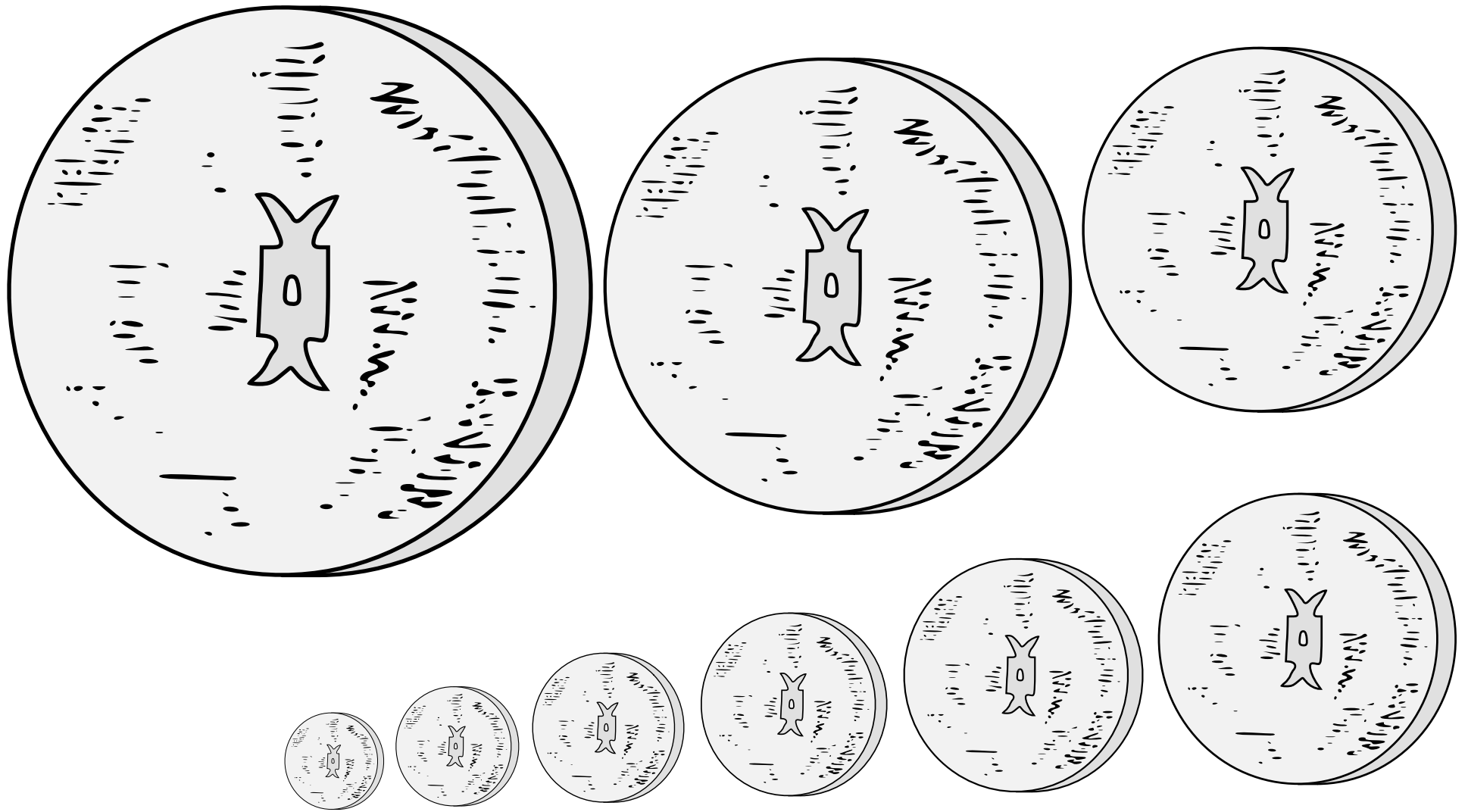

A circular grinding wheel.

Default orientation: affronty. No proper coloration.

Source: A Glossary of Terms Used in Heraldry. Artist: James or Irene Parker.

Millstone (2) 19.99

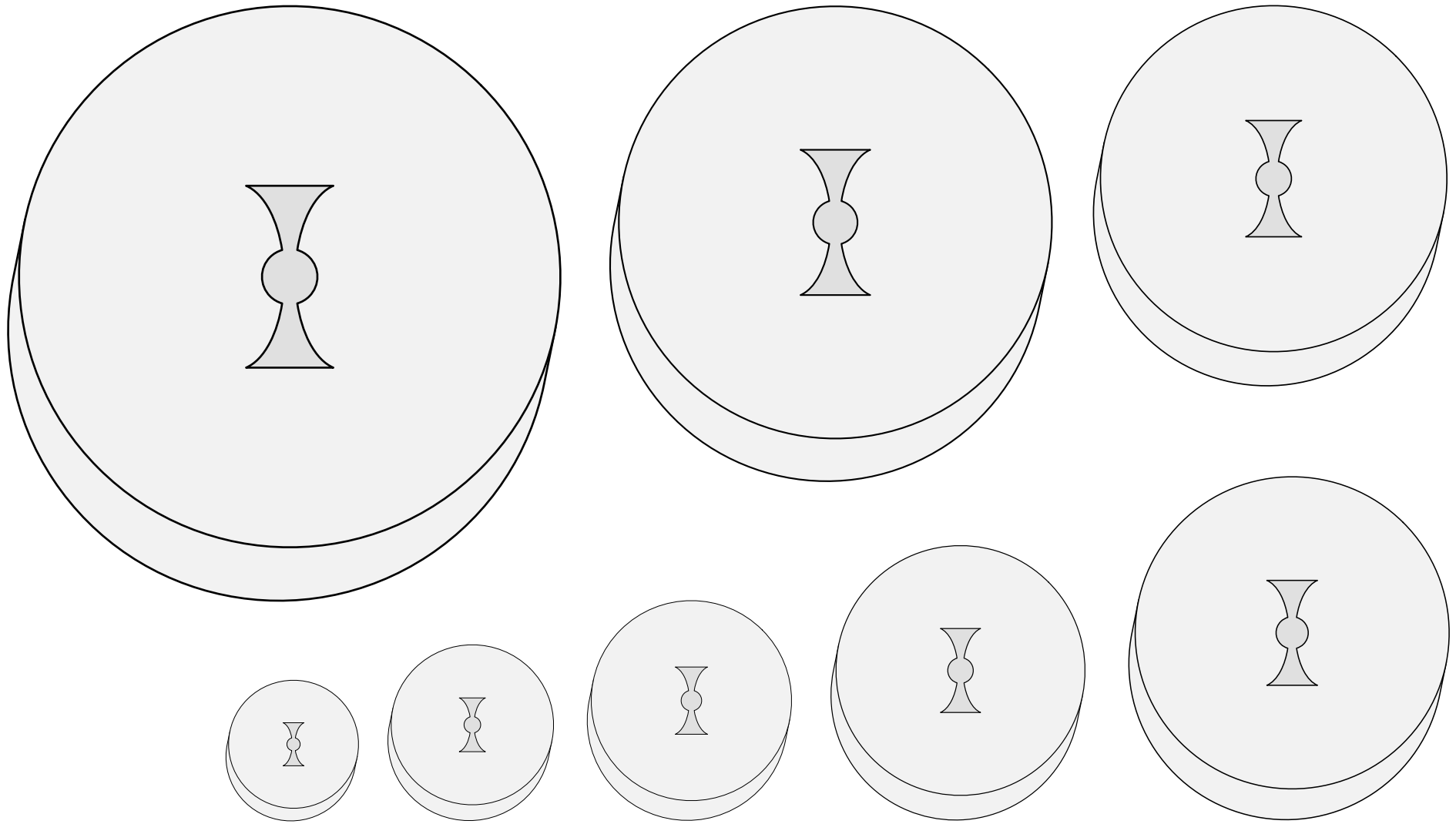

A circular grinding wheel.

Default orientation: affronty. No proper coloration.

Source: Nobiliario de Armas de Valencia, Aragón y Cataluña. Artist unknown.

Millstone (3) 19.100

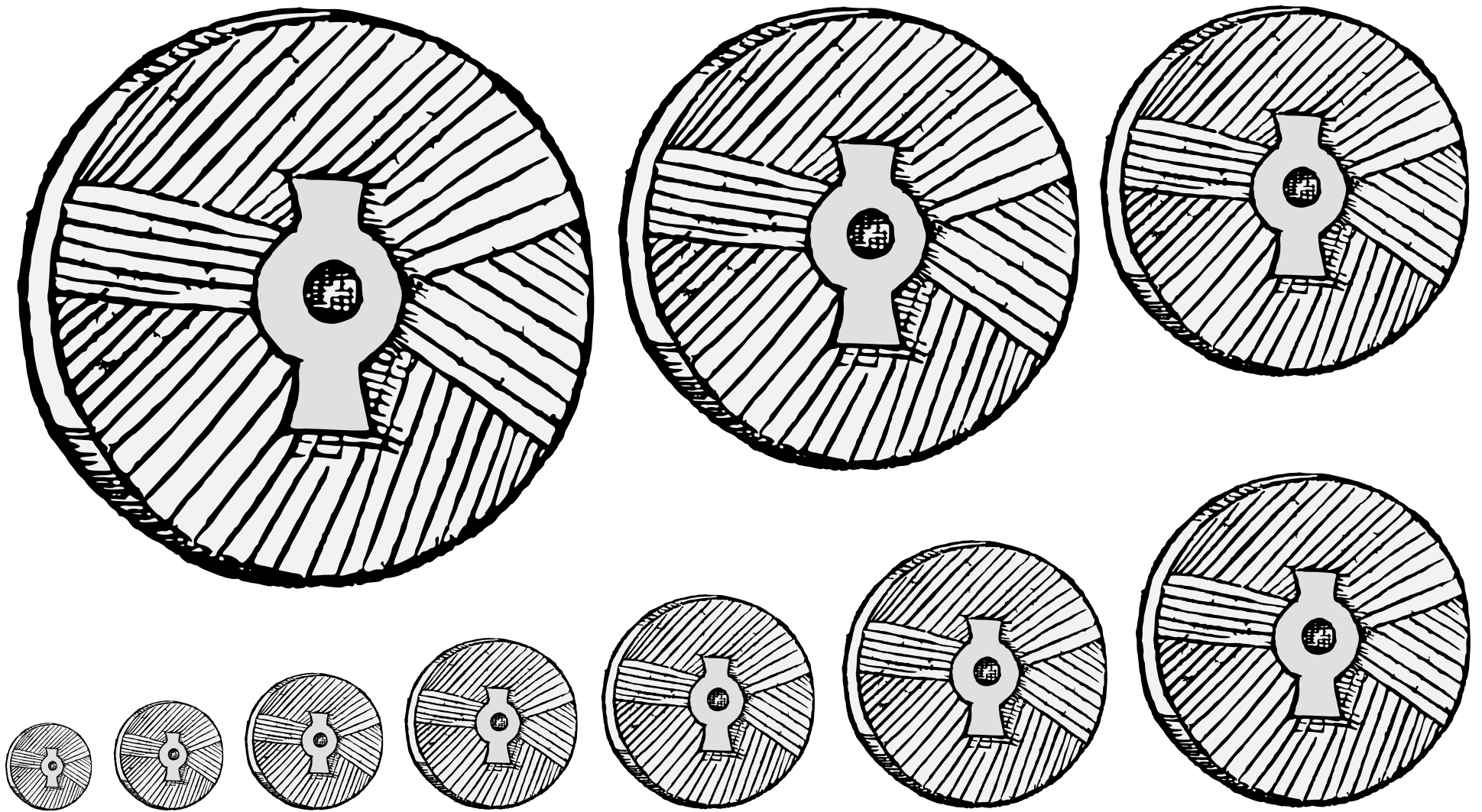

A circular grinding wheel.

Default orientation: affronty. No proper coloration.

Source: Arma Regni Poloniae. Artist unknown. (Herb of Ruczaba, p. 148.)

Millstone (4) 19.101

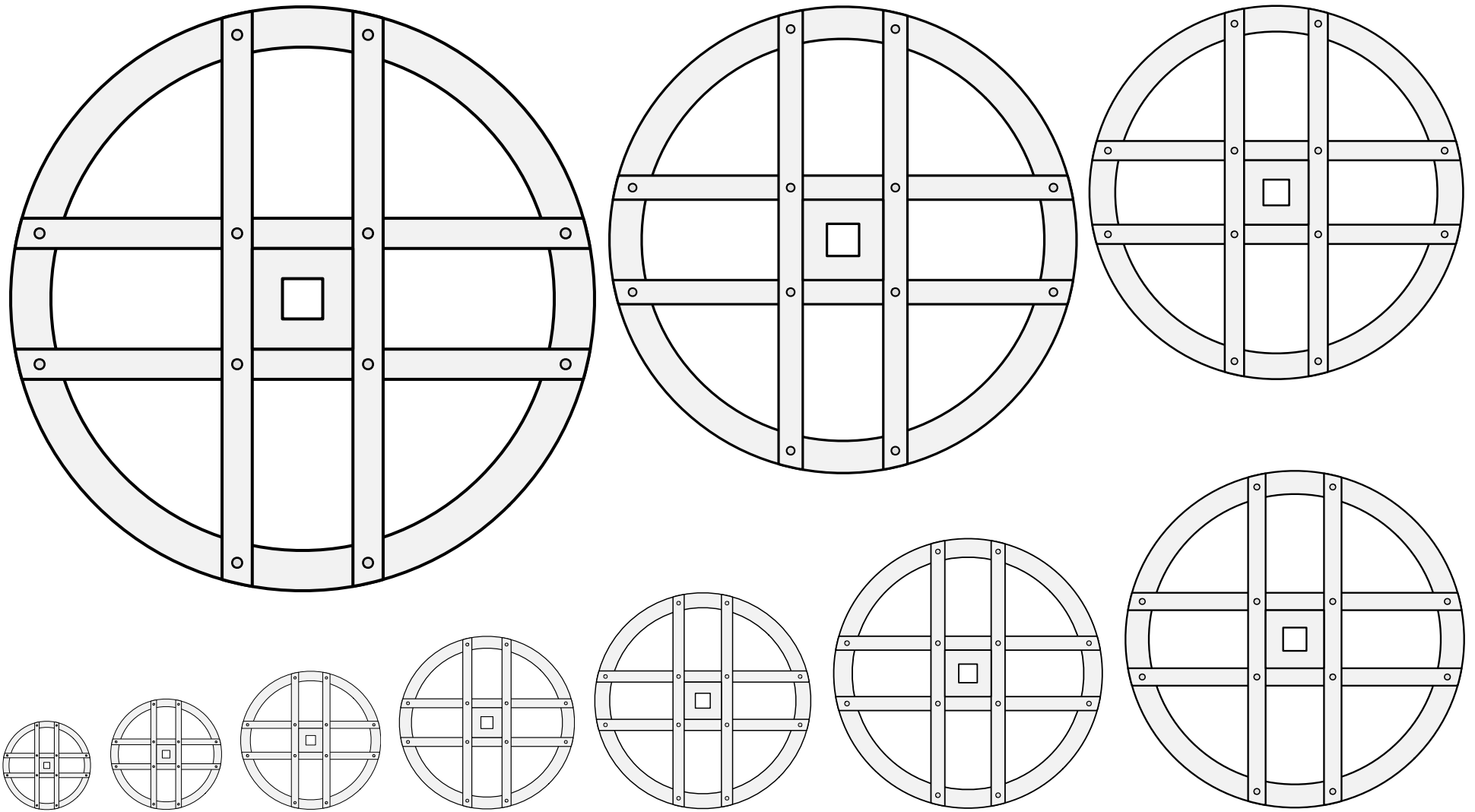

A circular water wheel used to power a mill.

Default orientation: in annulo. No proper coloration.

Source: De Re Metallica. Artist unknown. (Figure 189.)

Adapted by Mathghamhain Ua Ruadháin.

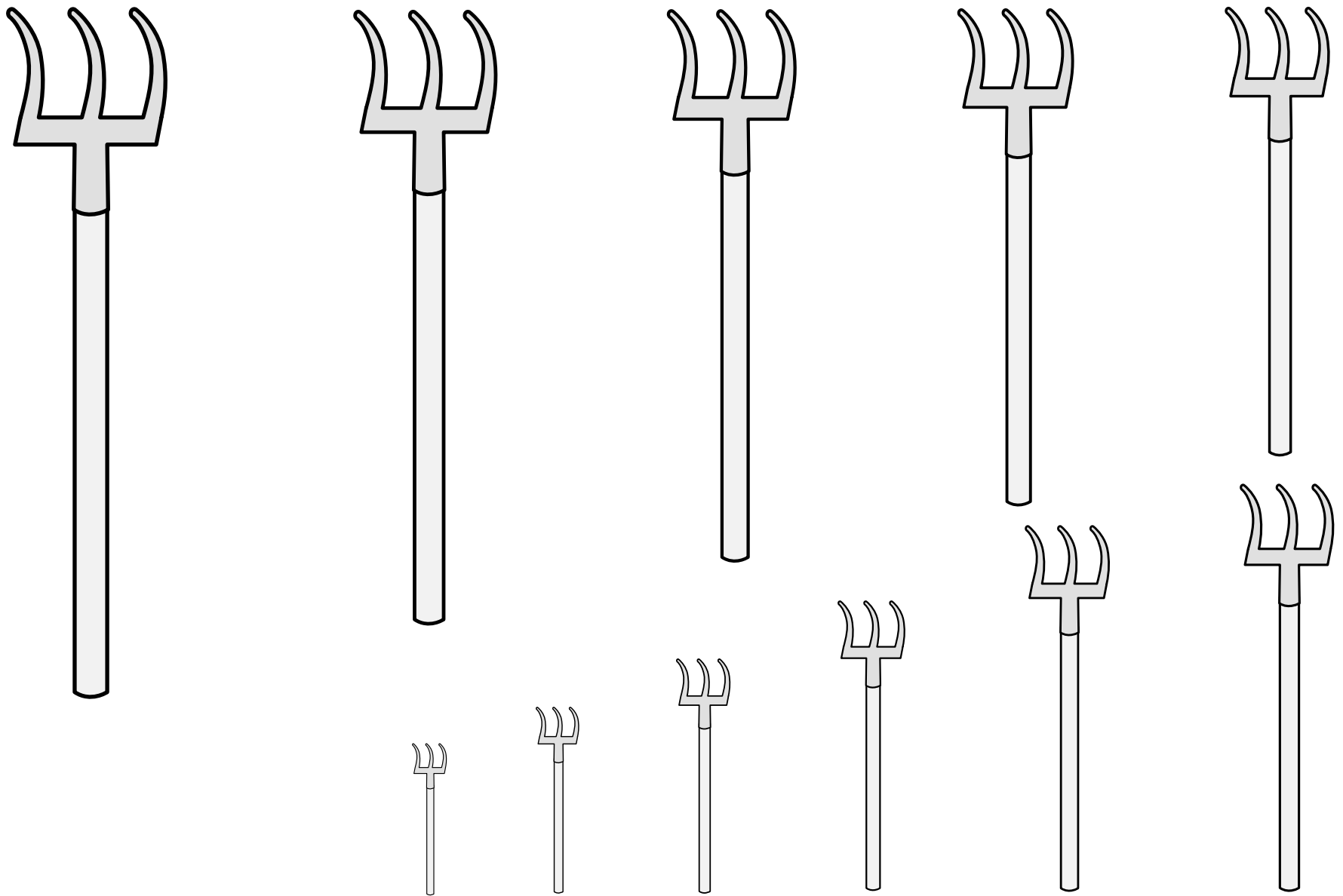

A long-handled tool for moving hay.

Default orientation: tines to chief. Proper coloration: brown wood.

Source: Rylands MS 2. Artist unknown. (Page 139.)

Pitchfork • 19.103

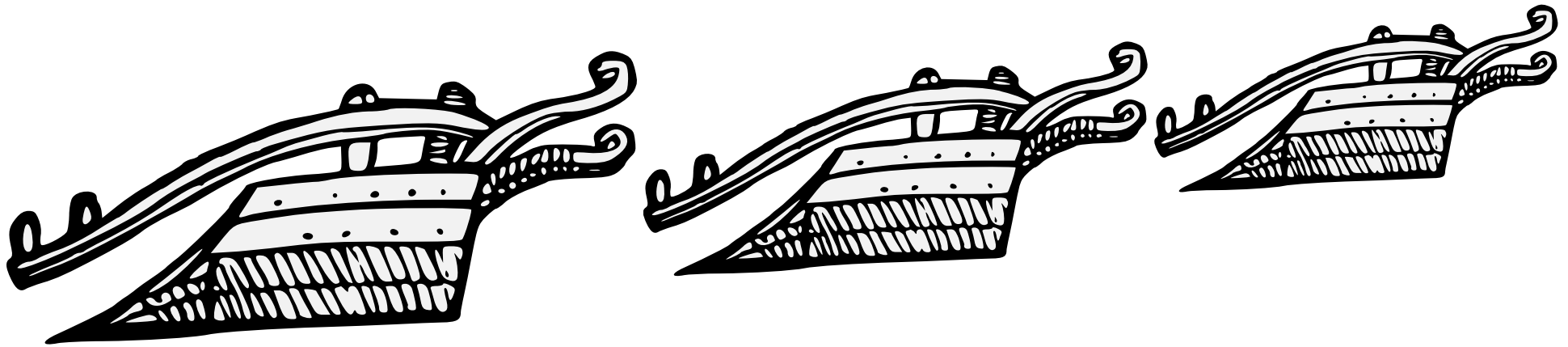

A farmer's implement for breaking up soil and turning it over before planting crops.

Default orientation: fesswise, pulling to dexter. No proper coloration.

Source: Workes of Armorie. Artist: John Bossewell.

Plow (1) 19.104

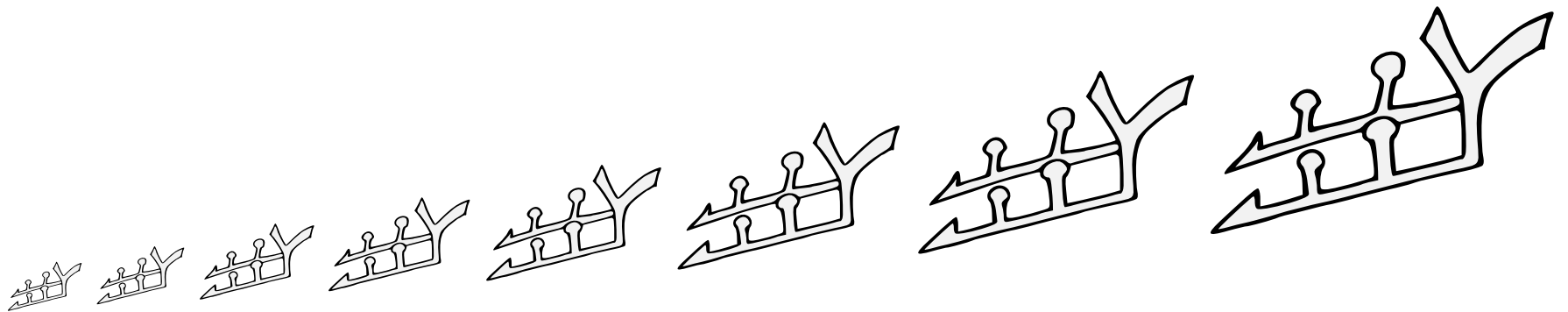
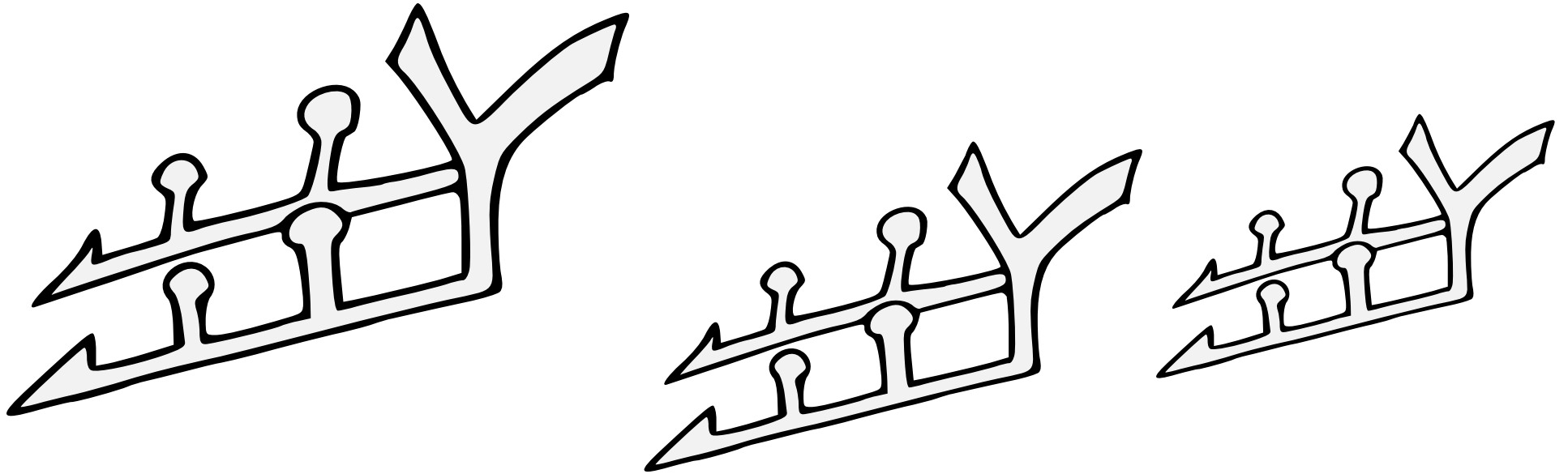

A farmer's implement for breaking up soil and turning it over before planting crops.

Default orientation: fesswise, pulling to dexter. No proper coloration.

Source: Pennsic Traceable Art. Artist: Roana d'Evreux.

Plow (2) 19.105

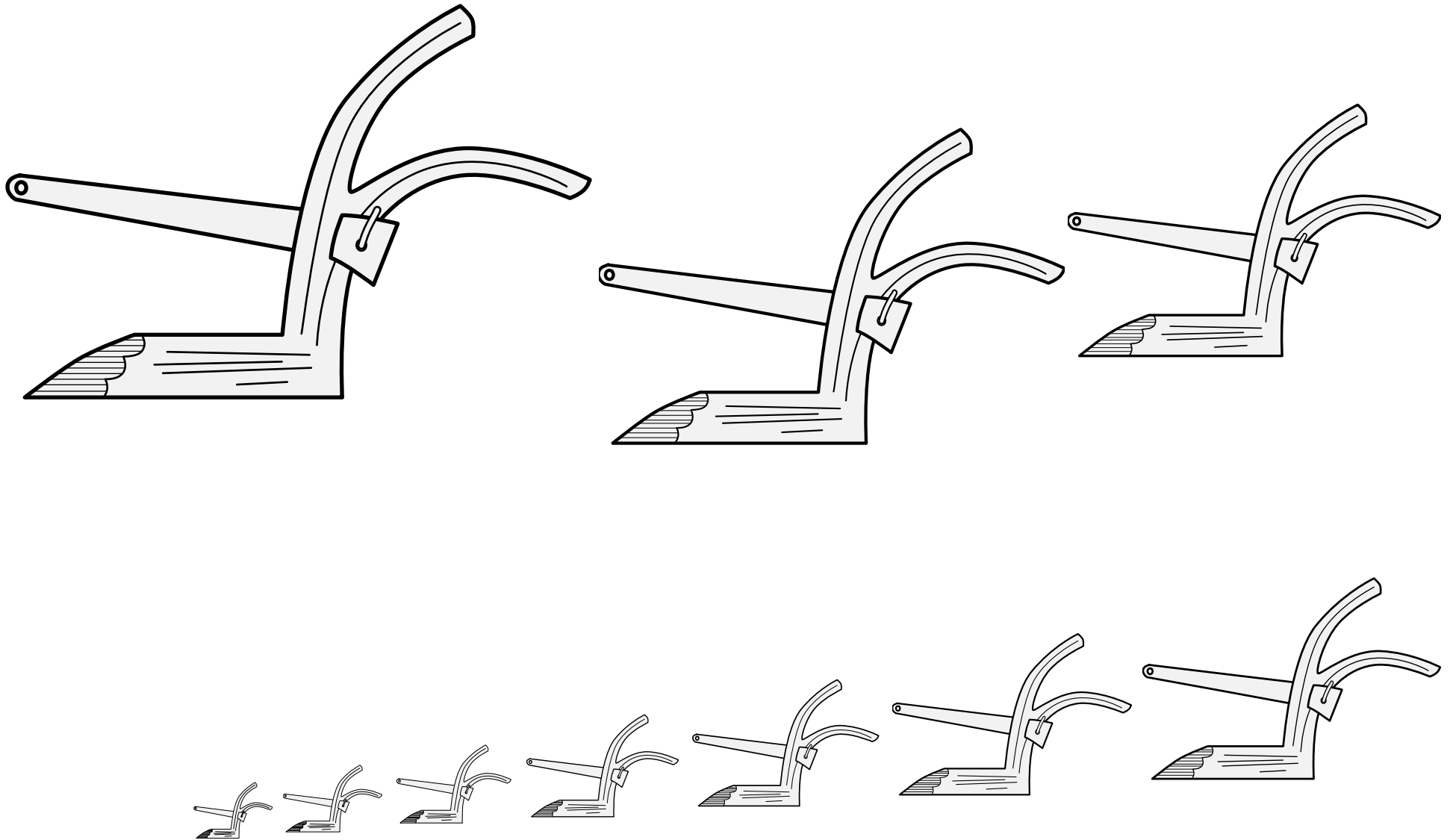

A farmer's implement for breaking up soil and turning it over before planting crops.

Default orientation: fesswise, pulling to dexter. No proper coloration.

Adapted from an illustration in British Library's Cotton MS Tiberius B V/1, early 12th C.

Plow (3) 19.106

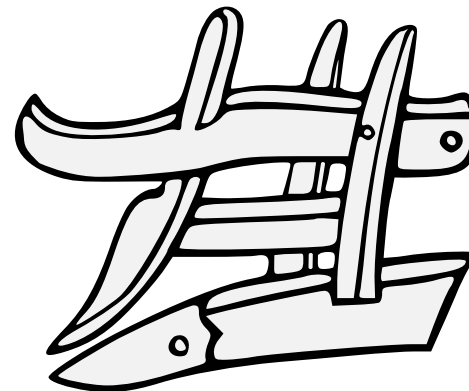
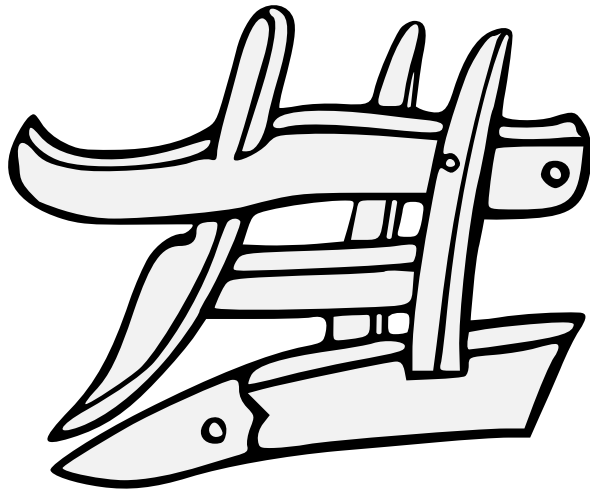
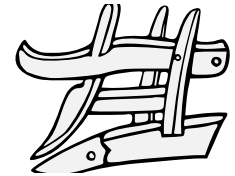
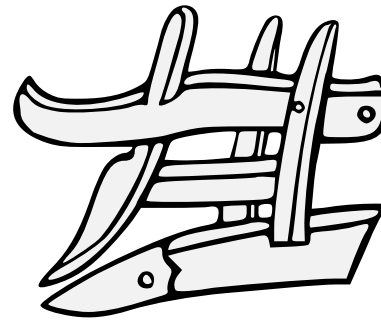
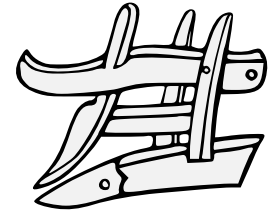
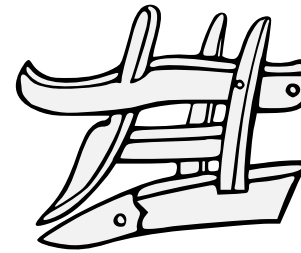
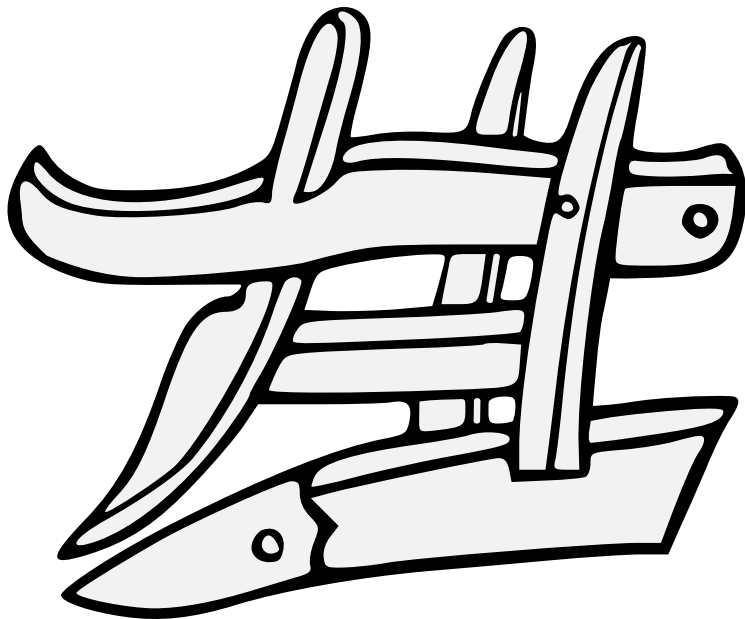

A farmer's implement for breaking up soil and turning it over before planting crops.

Default orientation: fesswise, pulling to dexter. No proper coloration.

Source: Two Tudor Books of Arms. Artist: Robert Cooke. (Page 61.)

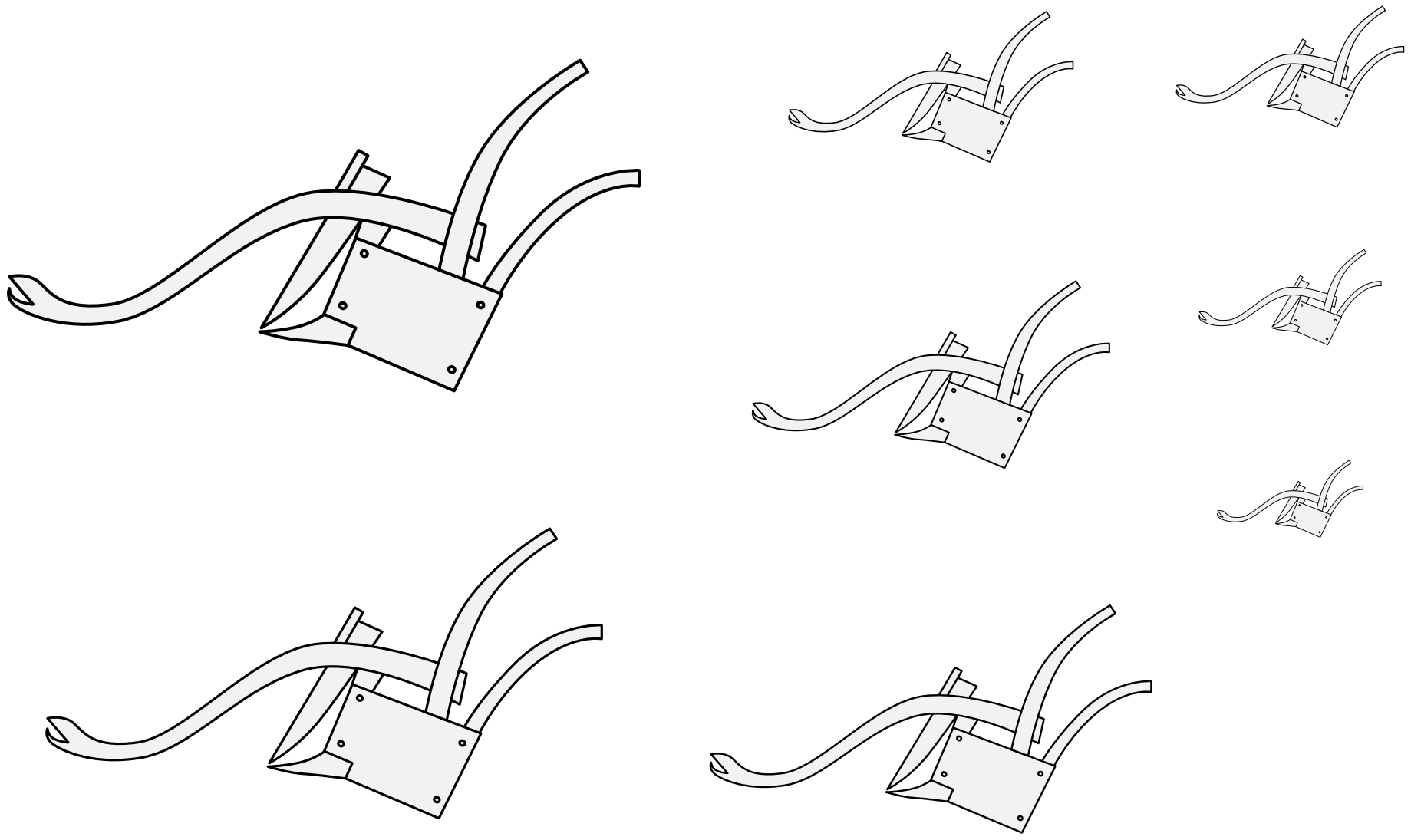

A farmer's implement for breaking up soil and turning it over before planting crops.
Default orientation: fesswise, pulling to dexter. No proper coloration.
Source: A Cyclopedia of Costume. Artist unknown. (Volume I, page 119.)

Plow (5) 19.108

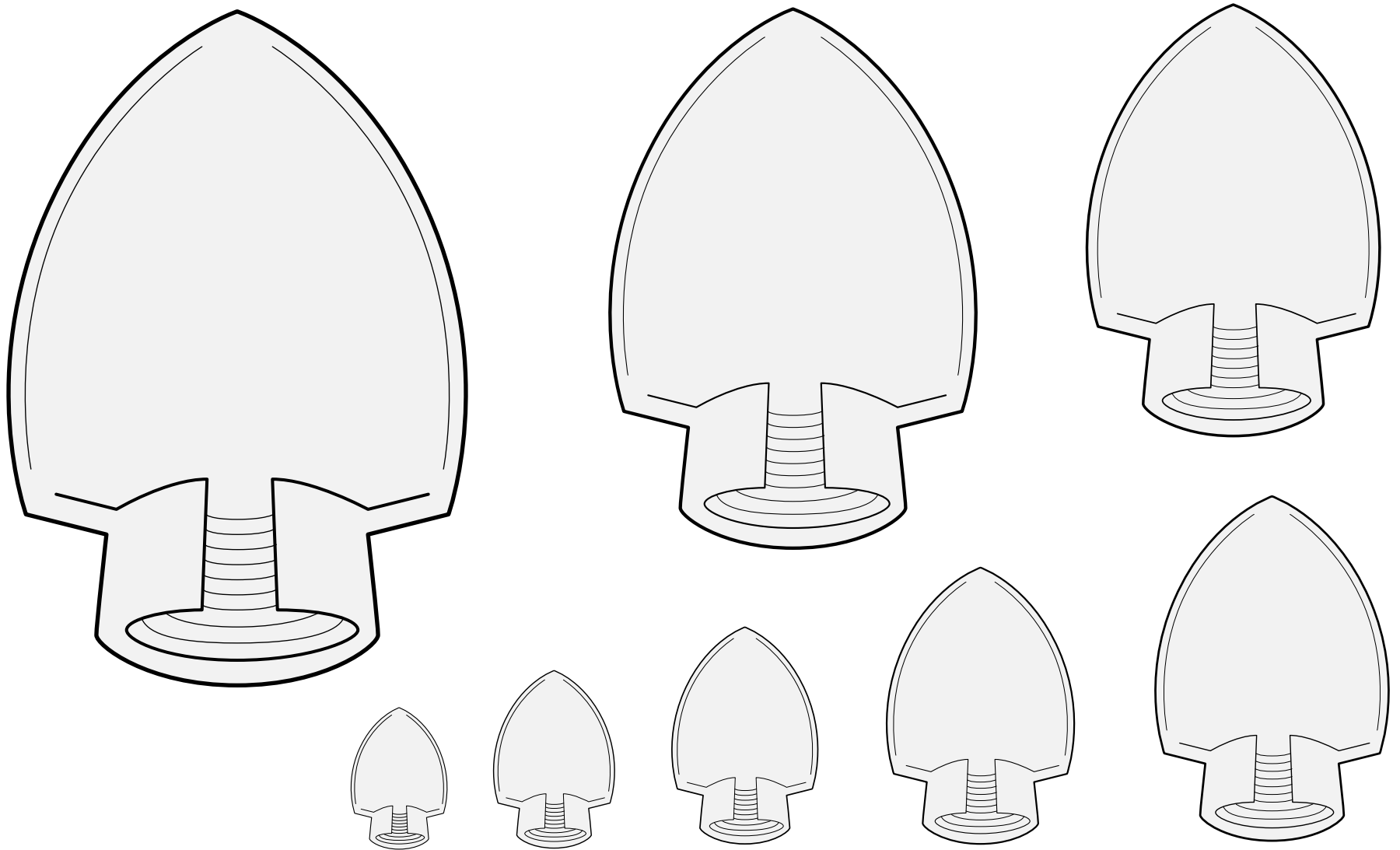

A blade used by farmers to break up the soil before planting.
Depicted with an open ferule at the base which would join it to the plow.

Default orientation: point to chief. No proper coloration.

Source: Neustifter Wappenbuch. Artist: Vigil Raber.
Adapted by Mathghamhain Ua Ruadháin.

Plowshare (1) 19.109

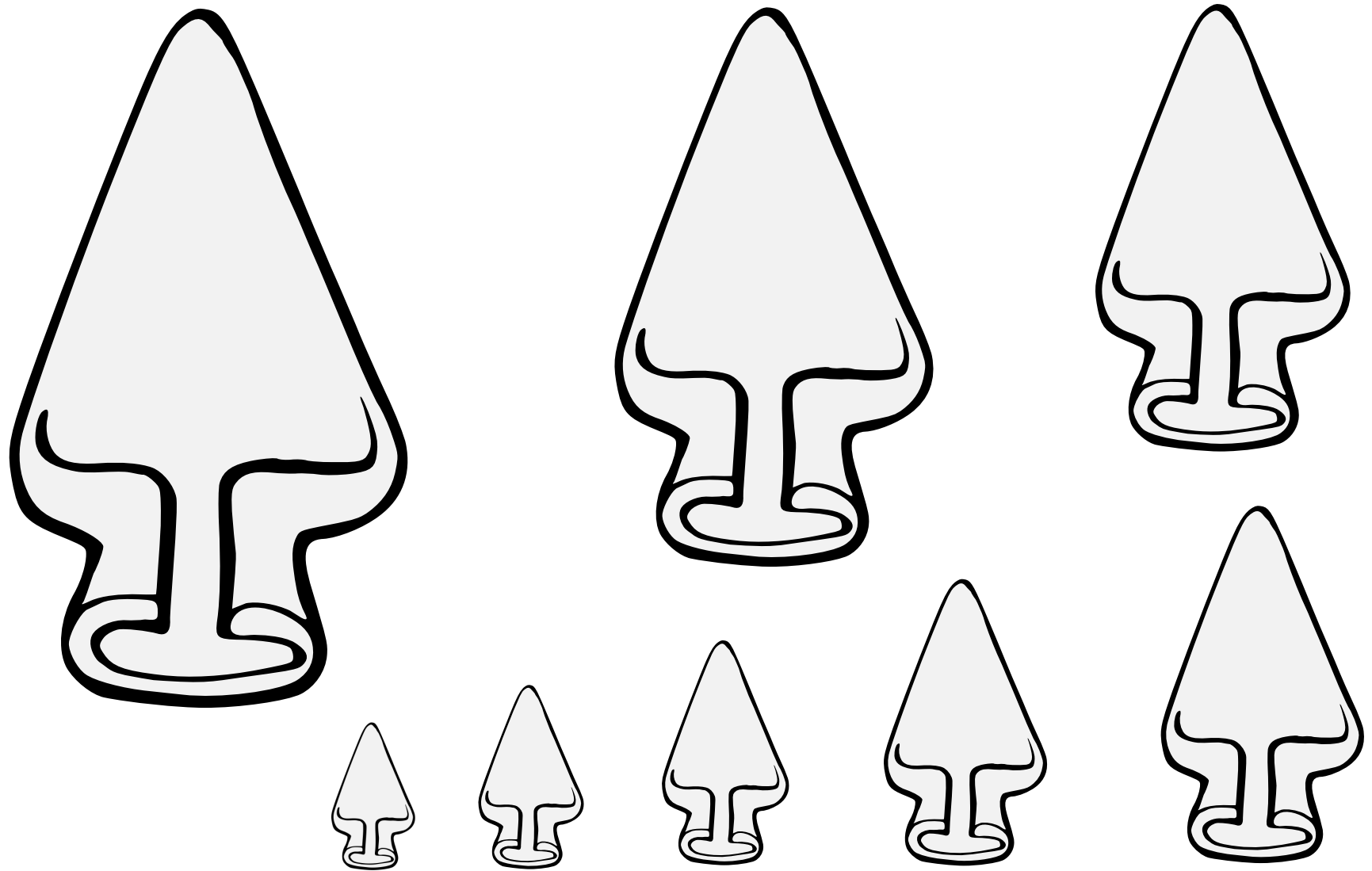

A blade used by farmers to break up the soil before planting.
Depicted with an open ferule at the base which would join it to the plow.

Default orientation: point to chief. No proper coloration.

Source: Scheibler Armorial. Artist unknown.
(Arms of Pflug von Schwarzenburg, folio 359.)

Plowshare (2) 19.110

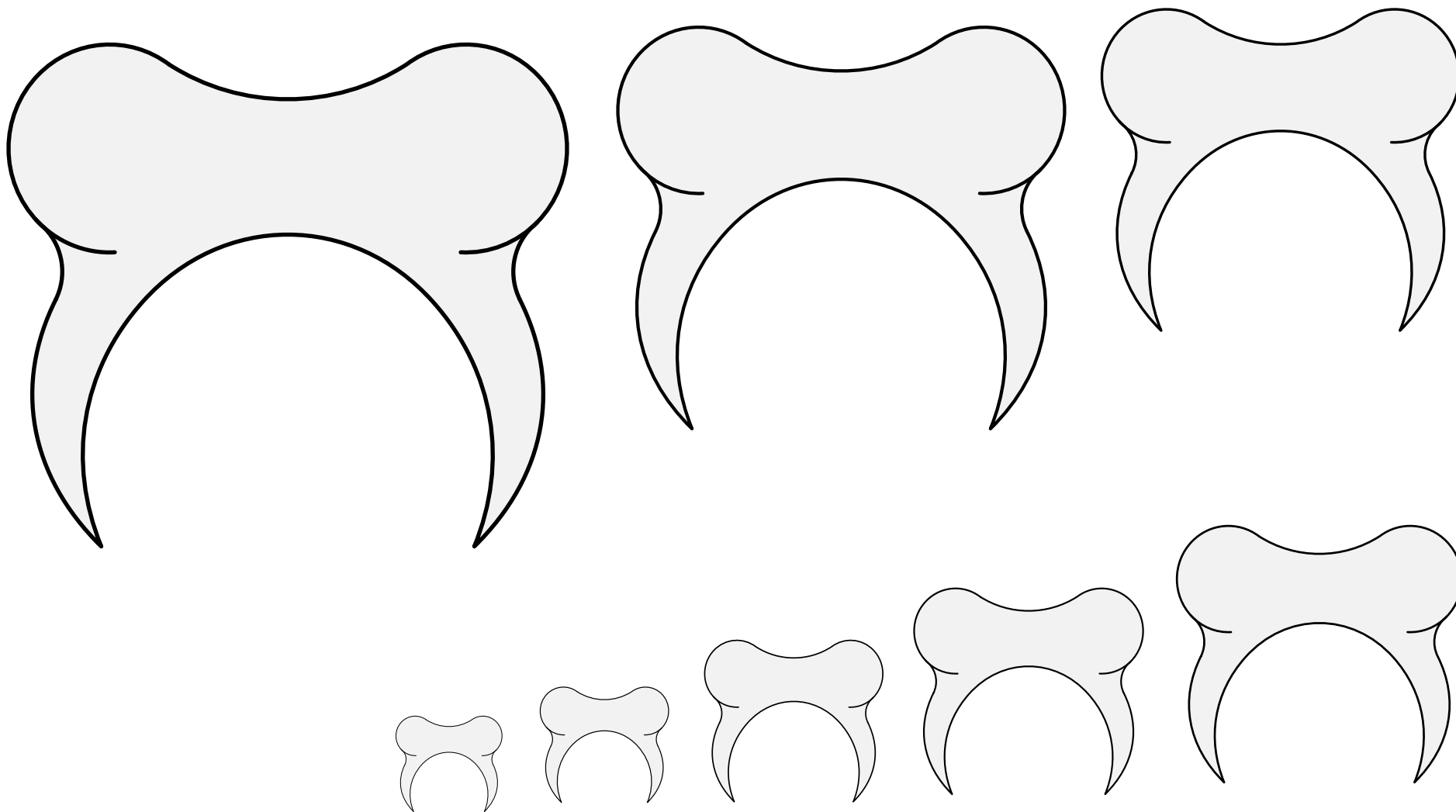

A raised area at the front of a saddle.

Default orientation: upright. No proper coloration.

Source: Stemmario Trivulziano. Artist: Gian Antonio da Tradate.
(From the arms of di Arzoni.)

Pommel, Saddle 19.111

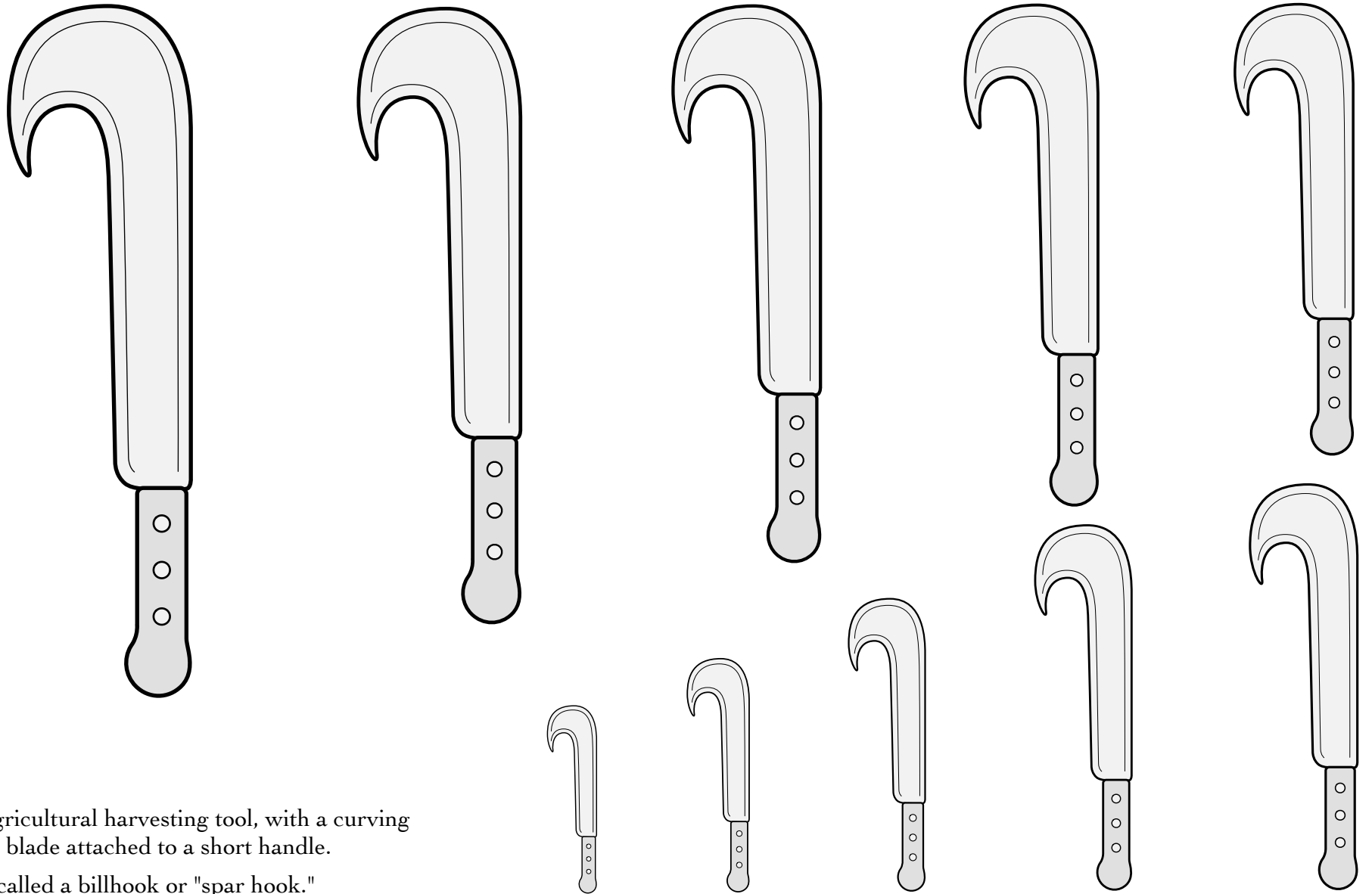

An agricultural harvesting tool, with a curving metal blade attached to a short handle.

Also called a billhook or "spar hook."

Default orientation: blade to chief. No proper coloration.

Source: Opus Insignium Armorumque. (Folio. 102)

Artist: Johann Weikhard von Valvasor.

Adapted by Mathghamhain Ua Ruadháin.

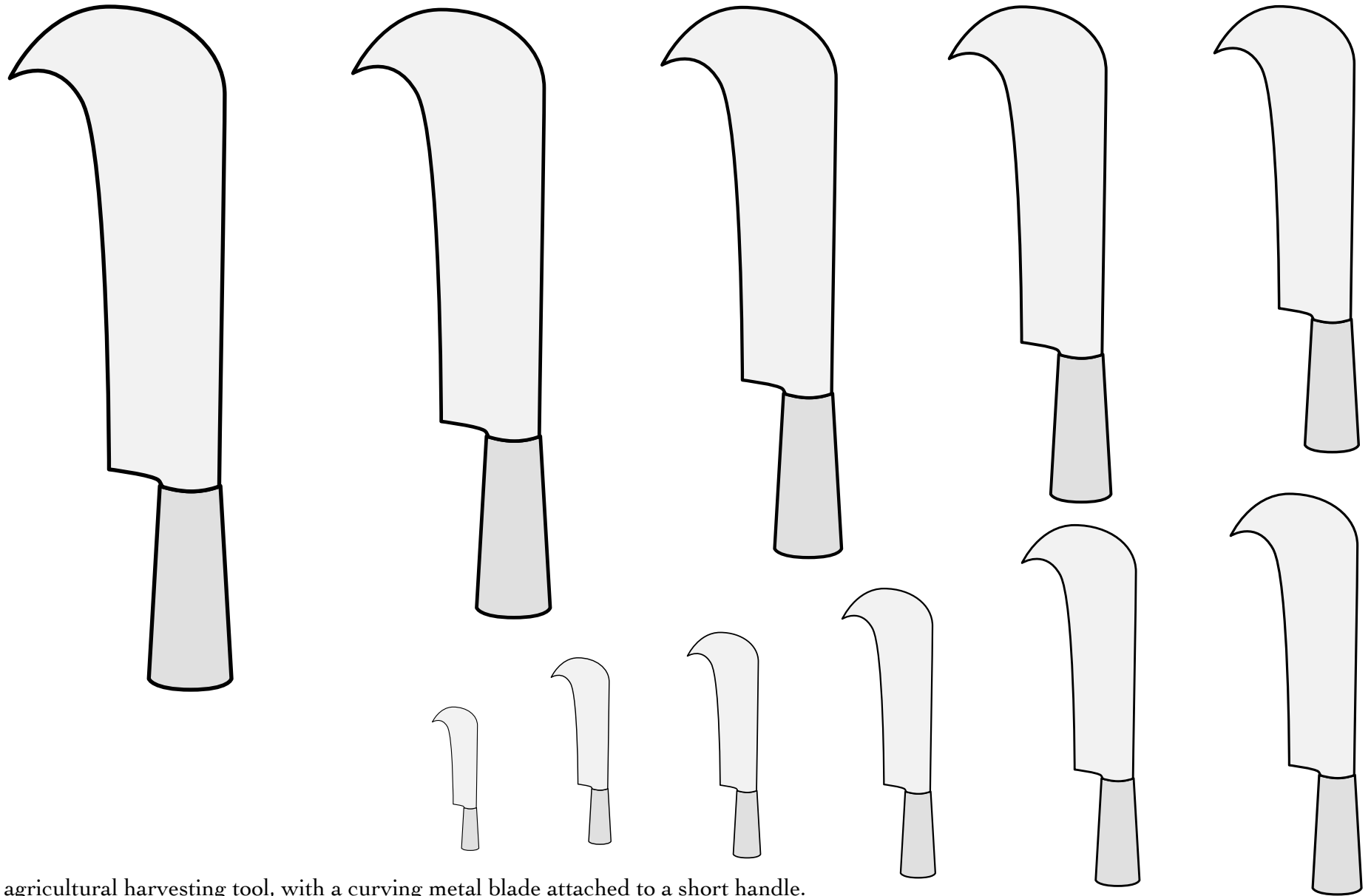

An agricultural harvesting tool, with a curving metal blade attached to a short handle.

Also called a billhook or "spar hook."

Default orientation: blade to chief. No proper coloration.

Adapted from images of traditional British billhooks.

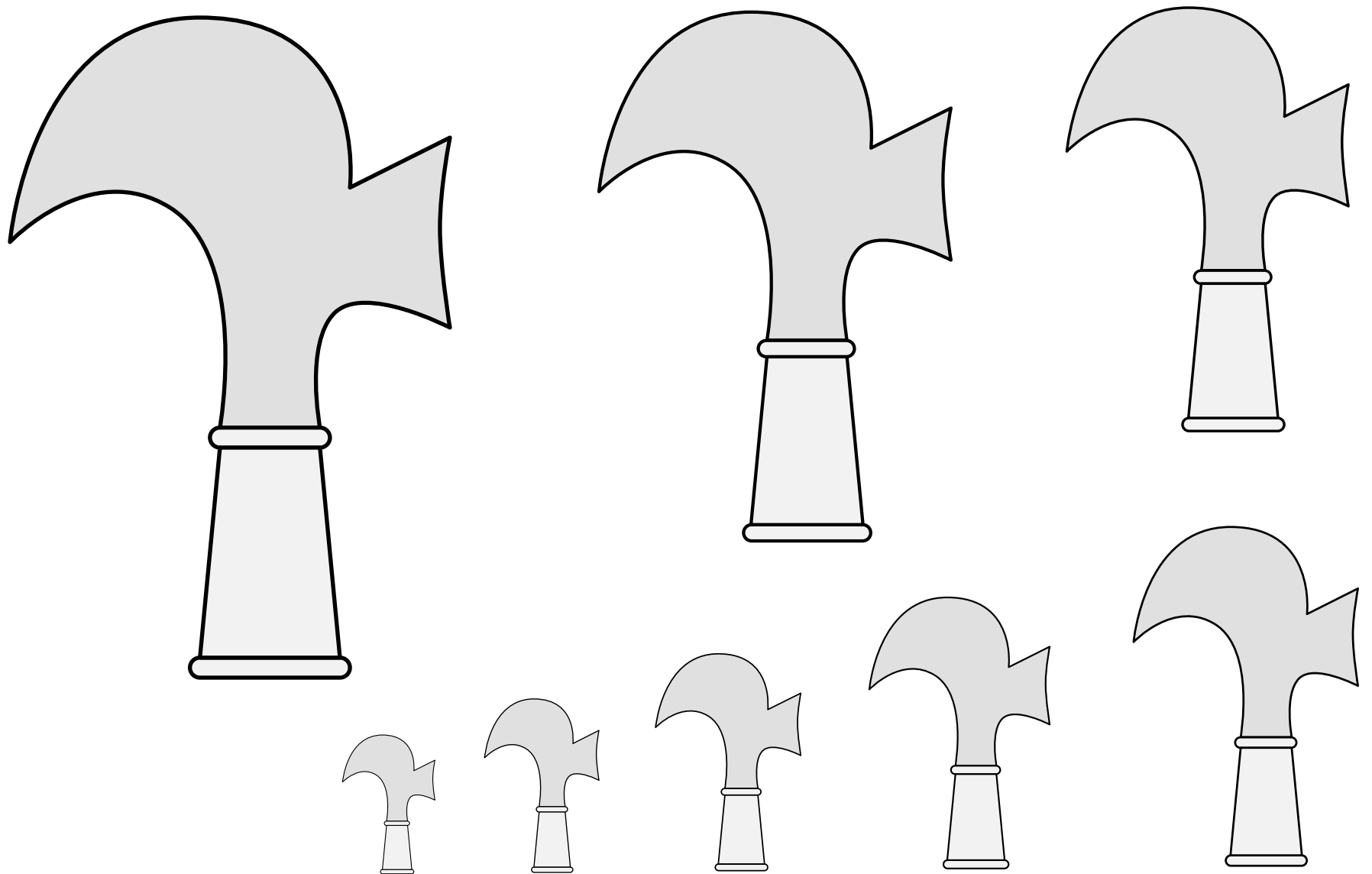

An agricultural harvesting tool, with a curving metal blade attached to a short handle.

Also called a billhook or "spar hook."

Default orientation: blade to chief. No proper coloration.

Source: Nobiliario de Armas de Valencia, Aragón y Cataluña. Artist unknown.

Pruning Knife (3) • 19.114

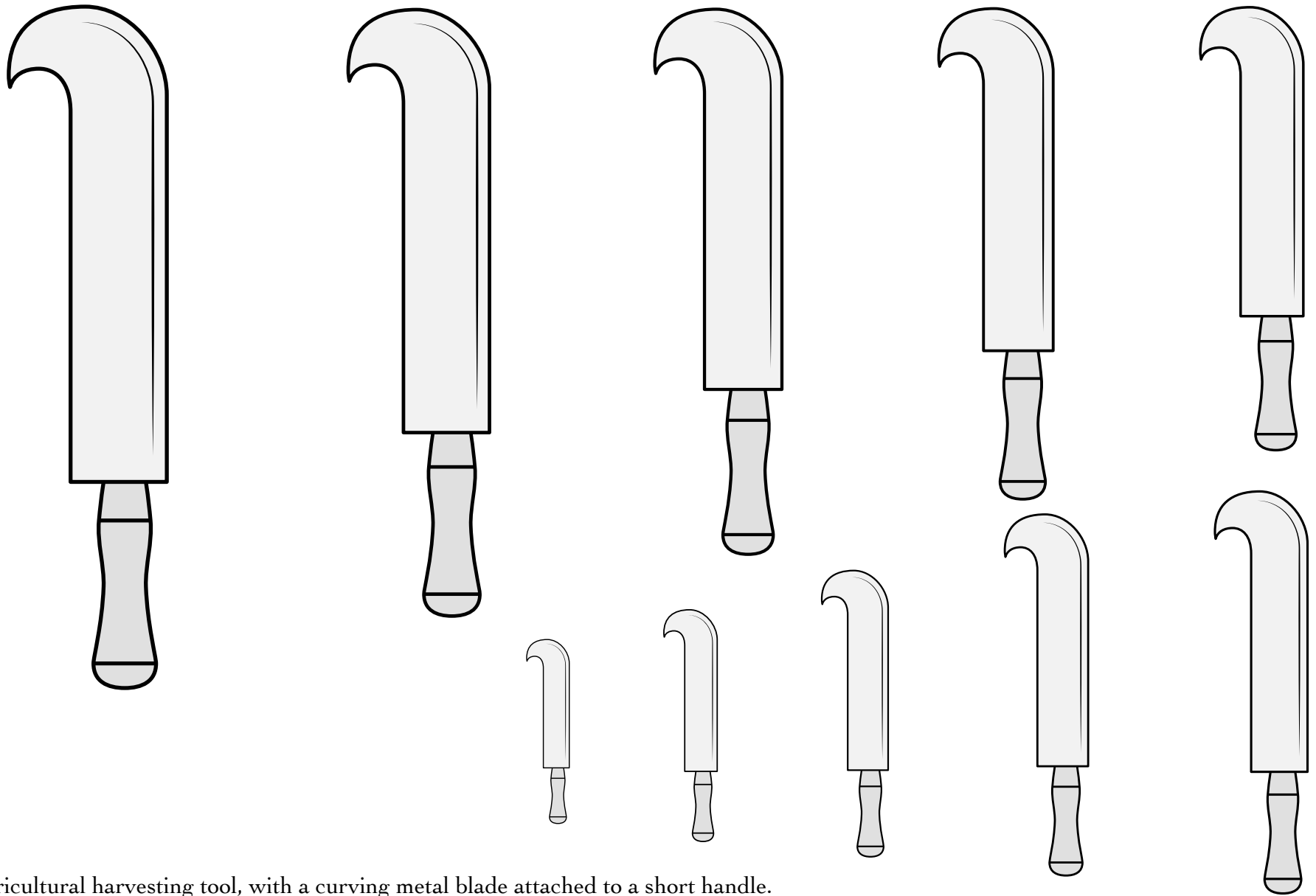

An agricultural harvesting tool, with a curving metal blade attached to a short handle.

Also called a billhook or "spar hook."

Default orientation: blade to chief. No proper coloration.

Source: WappenWiki. Artist: Joakim Spuller.

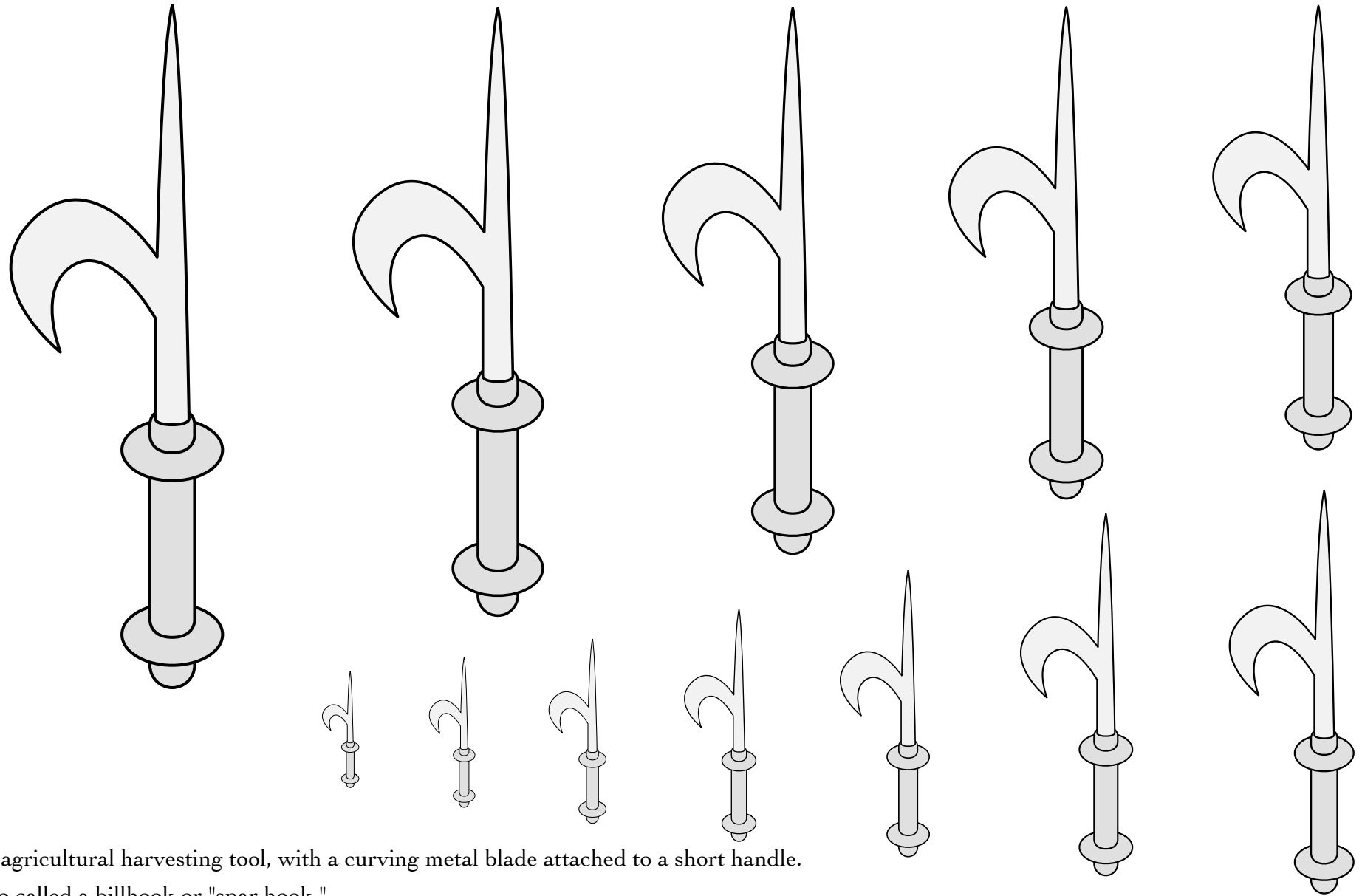

An agricultural harvesting tool, with a curving metal blade attached to a short handle.

Also called a billhook or "spar hook."

Default orientation: blade to chief. No proper coloration.

Source: Siebmacher's Wappenbuch of 1605. Artist: Johann Siebmacher.
(Arms of von Görlitz, page 62.)

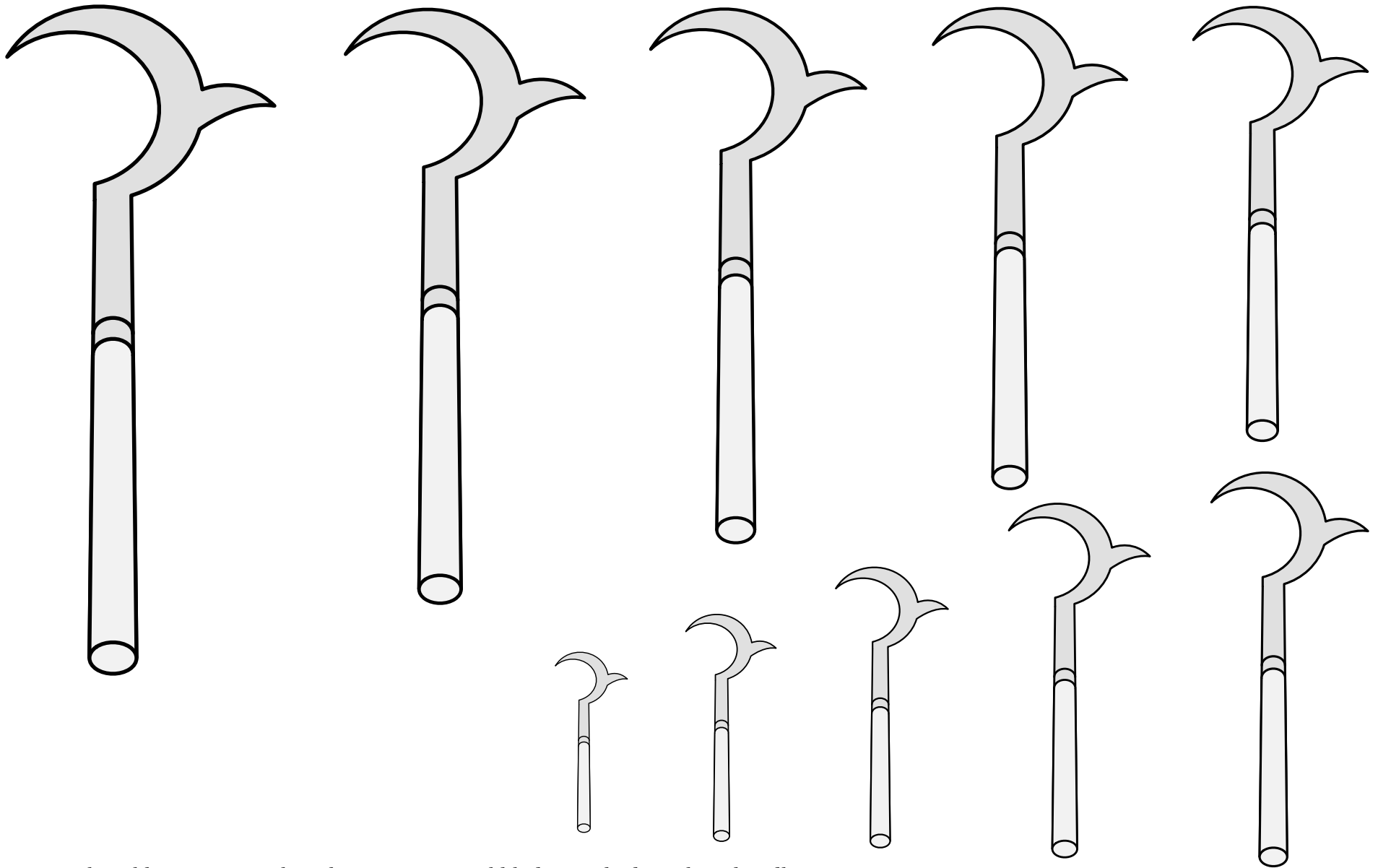

An agricultural harvesting tool, with a curving metal blade attached to a long handle.

Default orientation: blade to chief. No proper coloration.

Source: Wappenbuch der Arlberg-Bruderschaft.
Artist: Vigil Raber. (Page 401, arms of Hegner.)

Pruning Hook 19.117

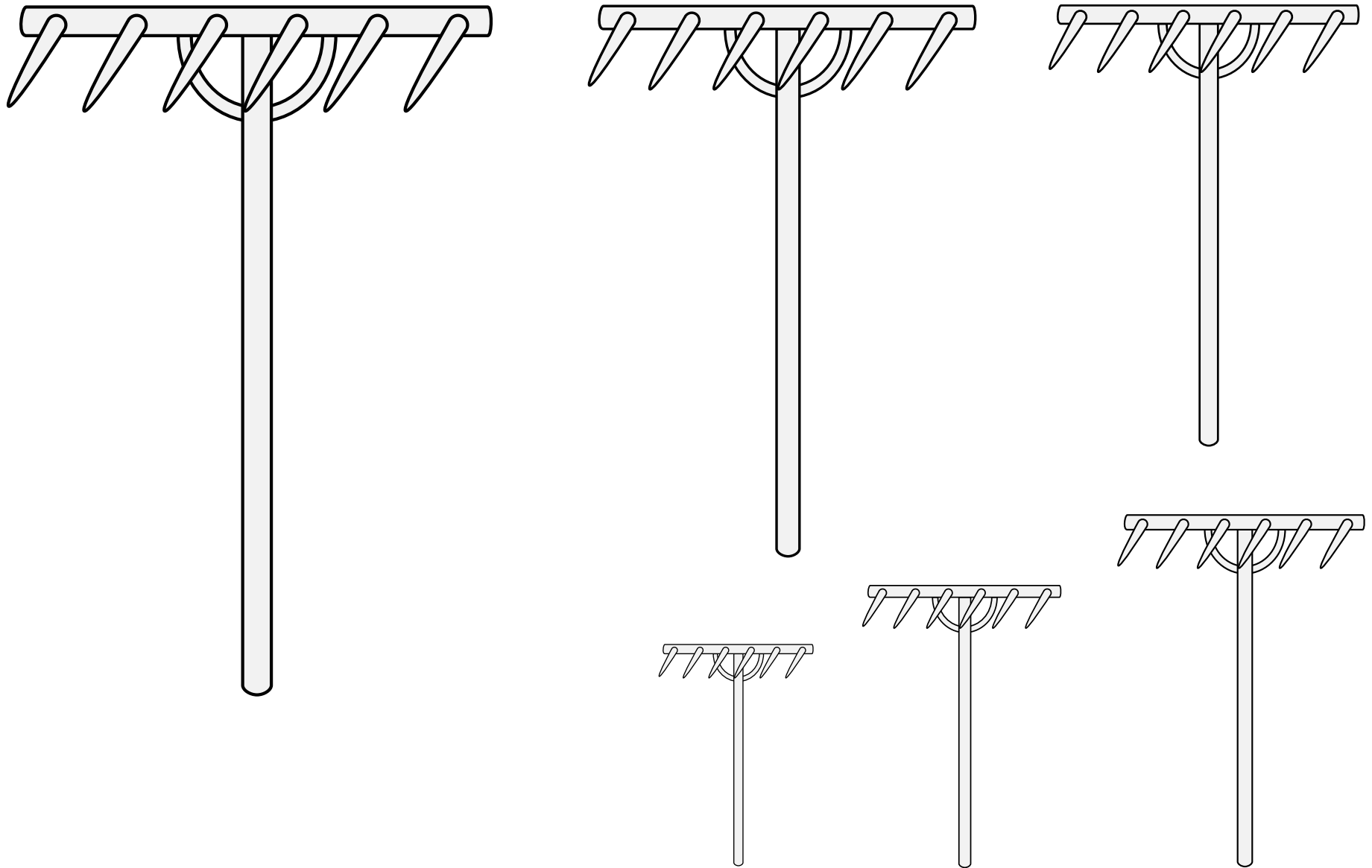

A gardening tool.

Default orientation: palewise, handle to base. Proper coloration: brown wood.

Source: De Ministrerio Armorum. (Arms of Erginger rechenberger.) Artist unknown.
Adapted by Mathghamhain Ua Ruadháin.

Rake (1) 19.118

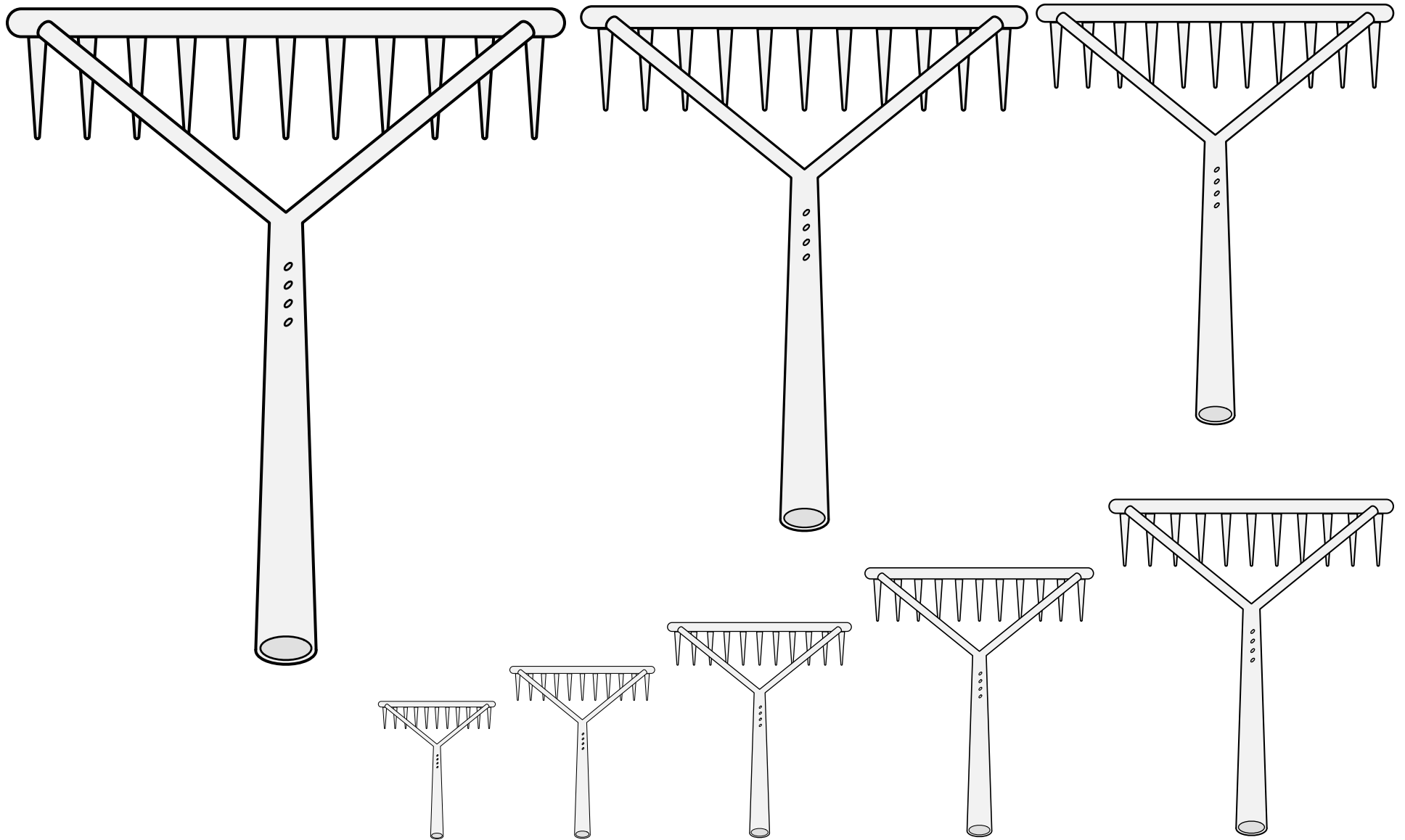

A gardening tool.

Default orientation: palewise, handle to base. Proper coloration: brown wood.

Source: Wappenbuch der Arlberg-Bruderschaft.

Artist: Vigil Raber. (Page 197.)

Rake (2) 19.119

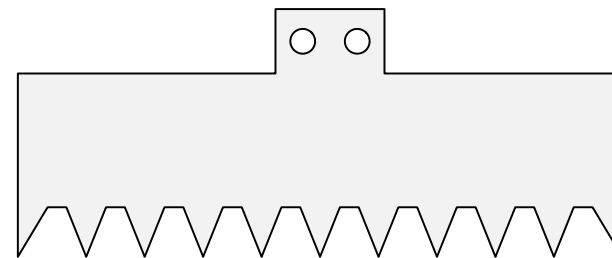
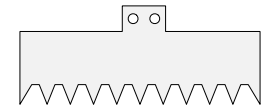
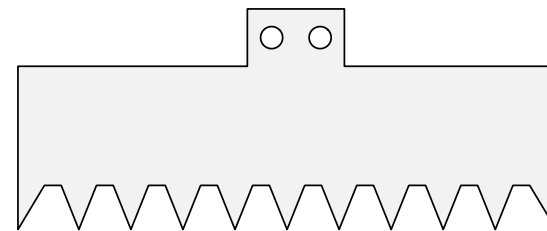
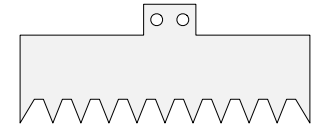
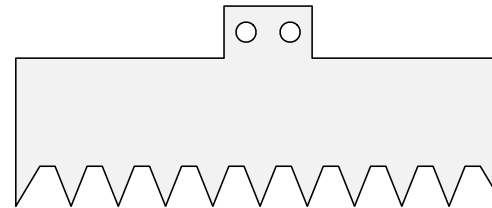
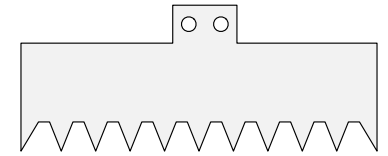
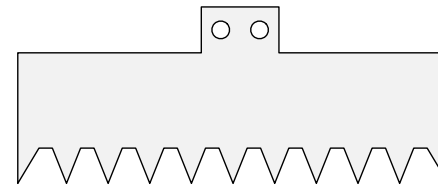
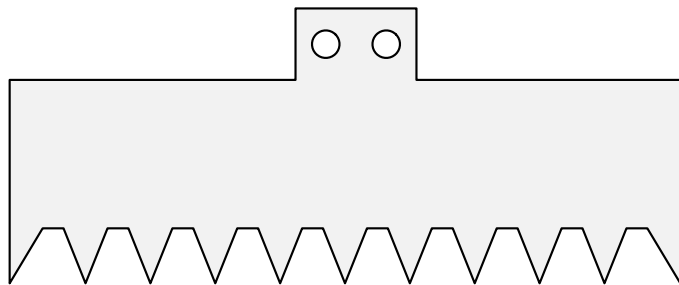
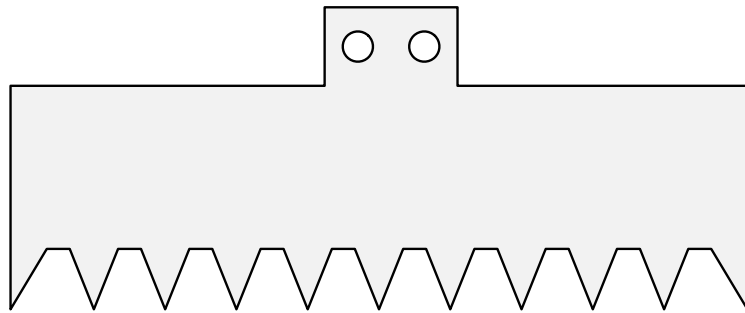
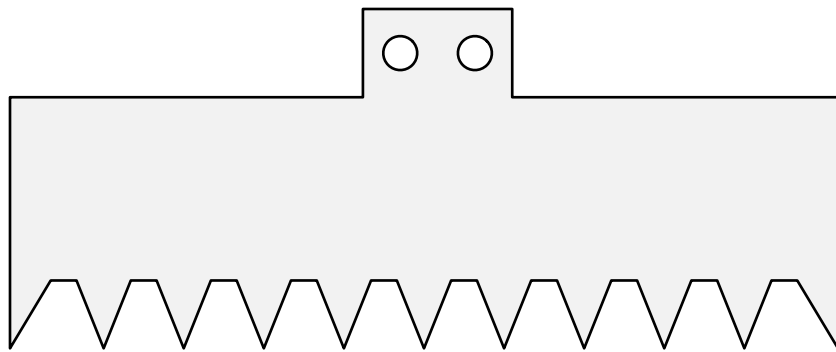

A gardening tool.

Default orientation: teeth to base. No proper coloration.

Source: Beyeren Armorial. Artist: Claes Heinenzoon.
(Arms of Count of Rethel, folio 1v.)

Rake Head (1) 19.120

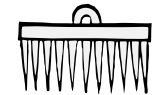
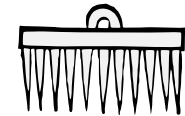
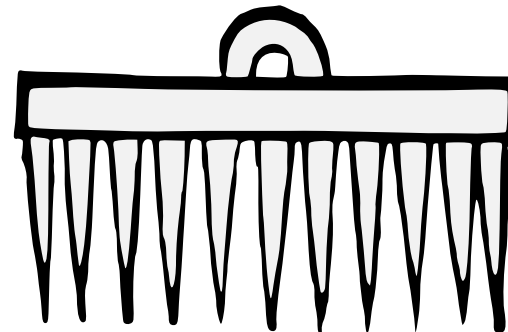
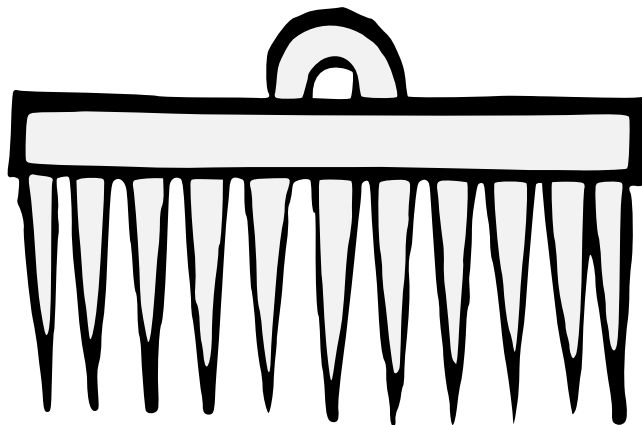
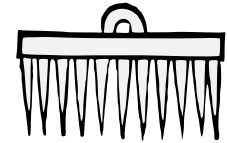
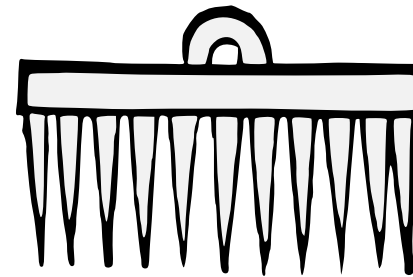
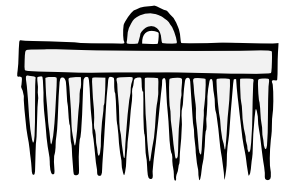
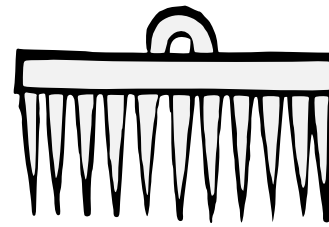
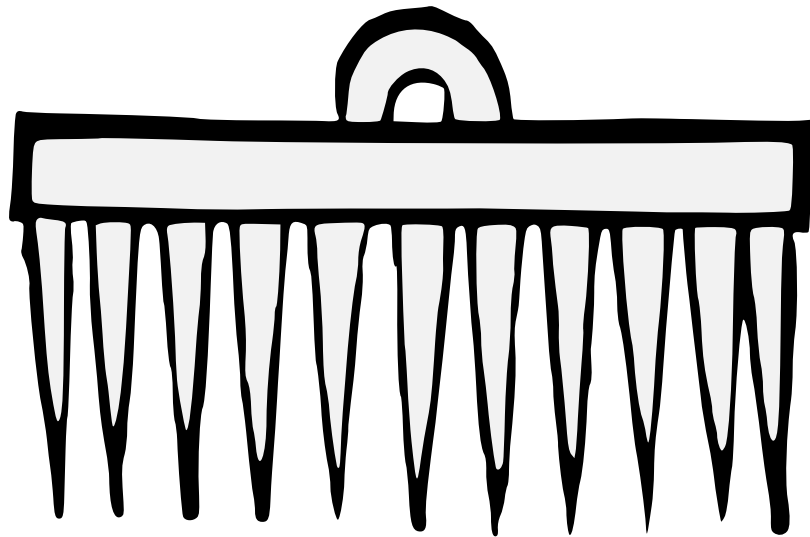

A gardening tool.

Default orientation: teeth to base. No proper coloration.

Source: Le Blason Des Armoiries. Artist: Jérôme de Bara. (Page 230.)

Rake Head (2) 19.121

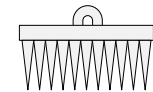
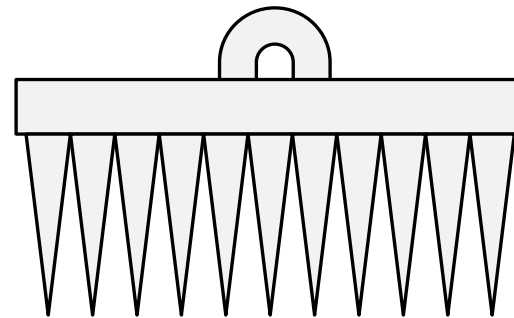
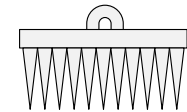
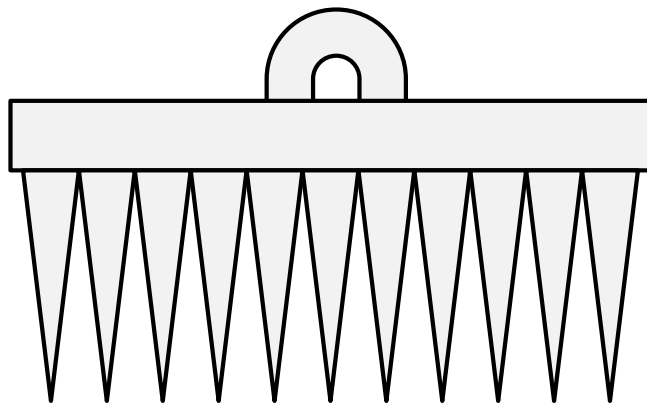
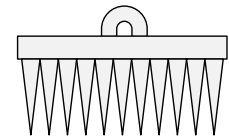
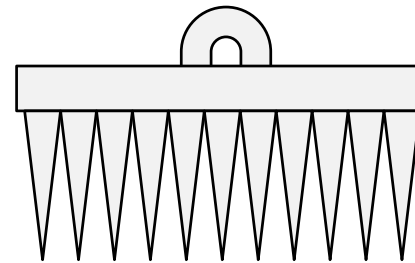
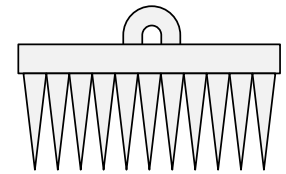
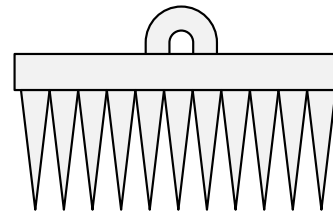
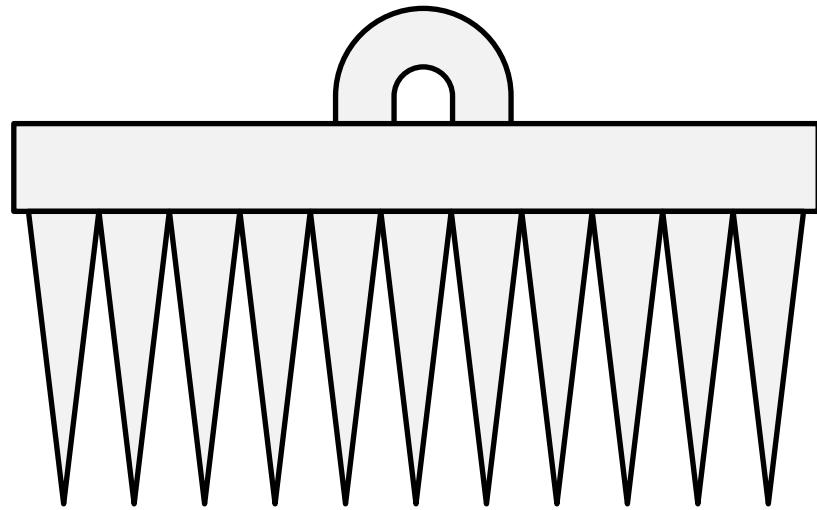

A gardening tool.

Default orientation: teeth to base. No proper coloration.

Source: Le Blason Des Armoiries. Artist: Jérôme de Bara. (Page 230.)

Rake Head (3) 19.122

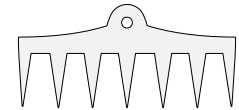
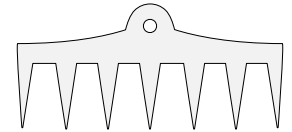
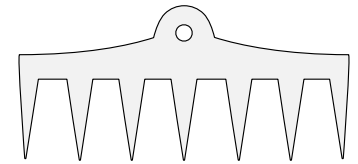
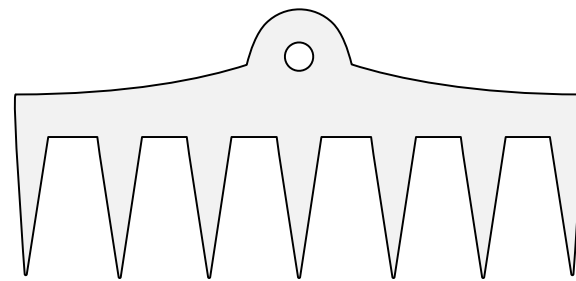
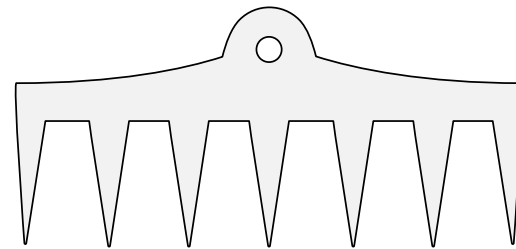
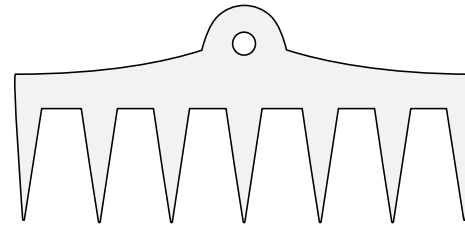
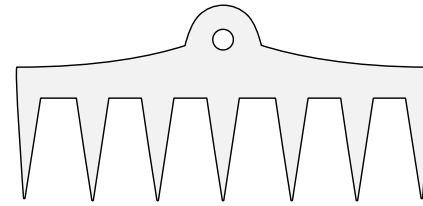
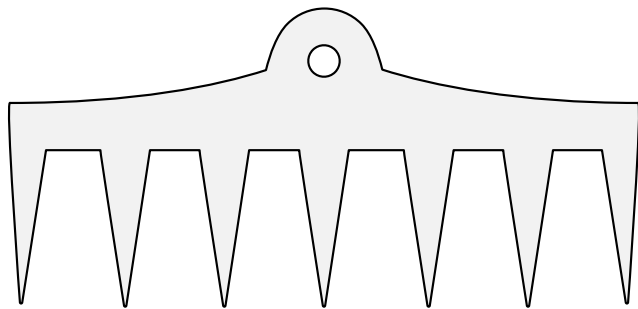
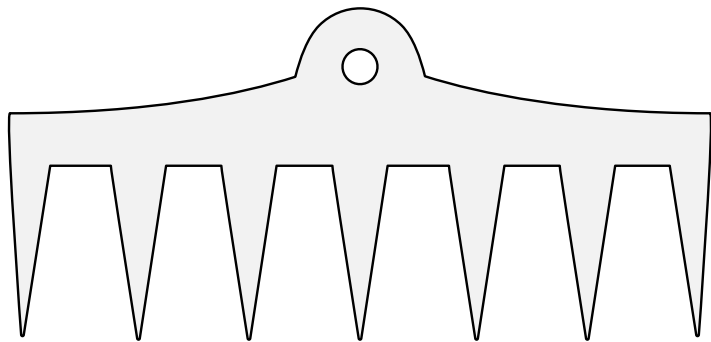
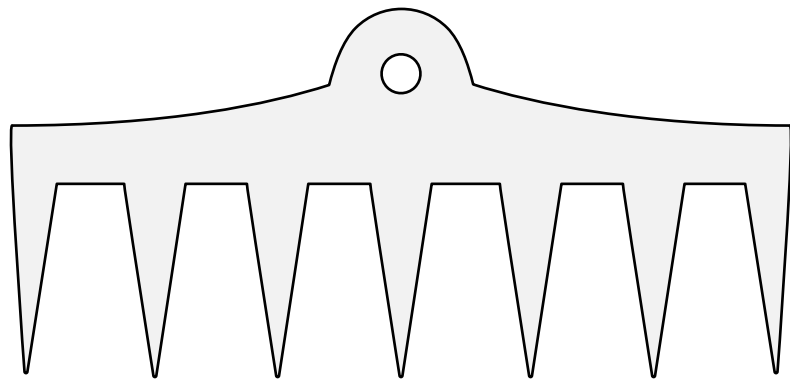

A gardening tool.

Default orientation: teeth to base. No proper coloration.

Source: Commonplace Book of Heraldry. (Folio 56r.)

Artist: Jean Faucket. Adapted by Mathghamhain Ua Ruadháin.

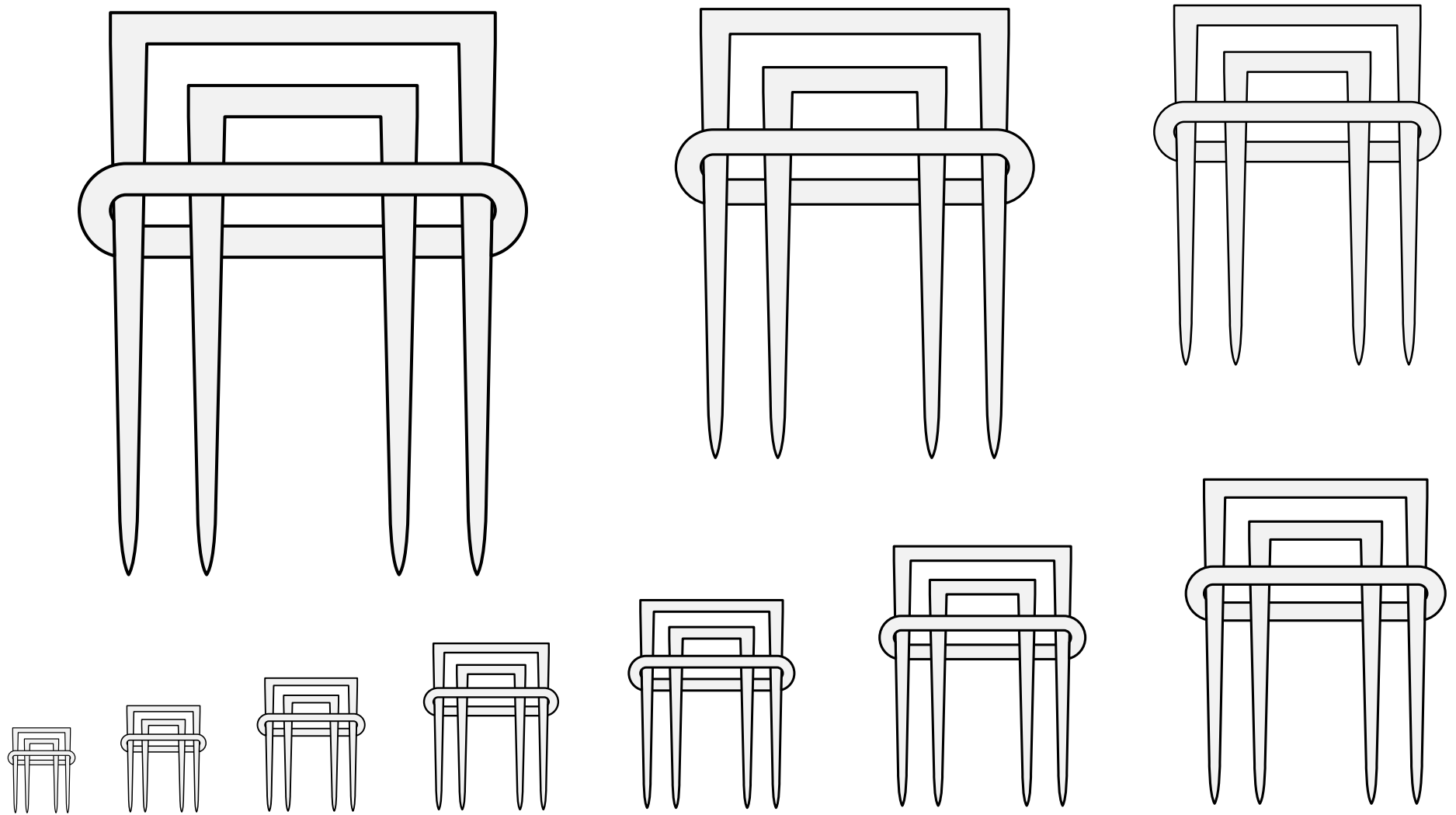

An Iberian charge, generally understood to represent a form of rake head.

Default orientation: teeth to base. No proper coloration.

Source: Armas o Blasones de Familias Diferentes. Artist: Jerónimo de Bolea. (Page 225.)

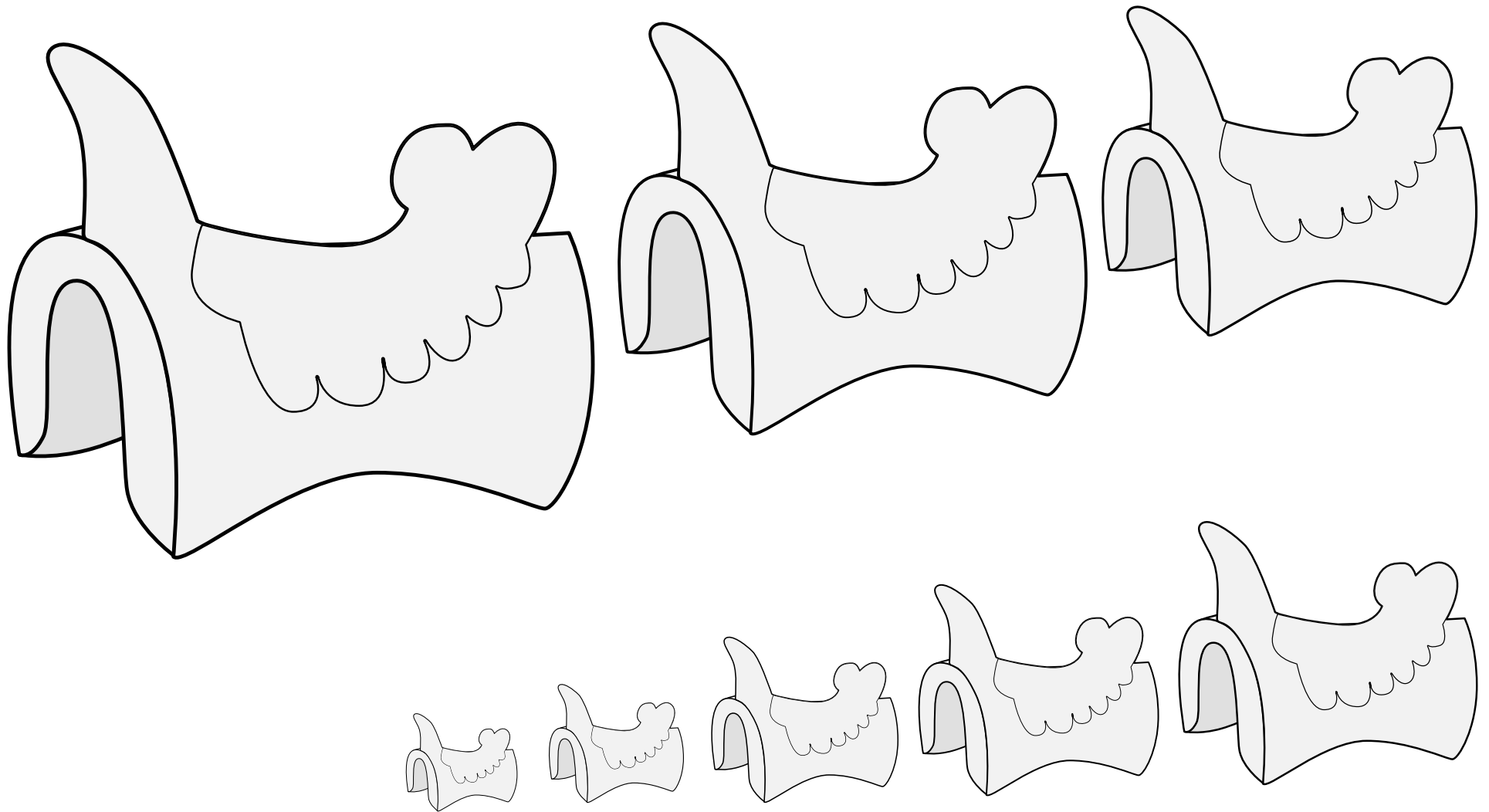

A seat that can be rested on a beast's back to make it easier to ride.

Default orientation: upright, facing dexter. Proper coloration: brown leather.

Source: Siebmacher's Wappenbuch of 1605. Artist: Johann Siebmacher. (Arms of Die Sattelin.)

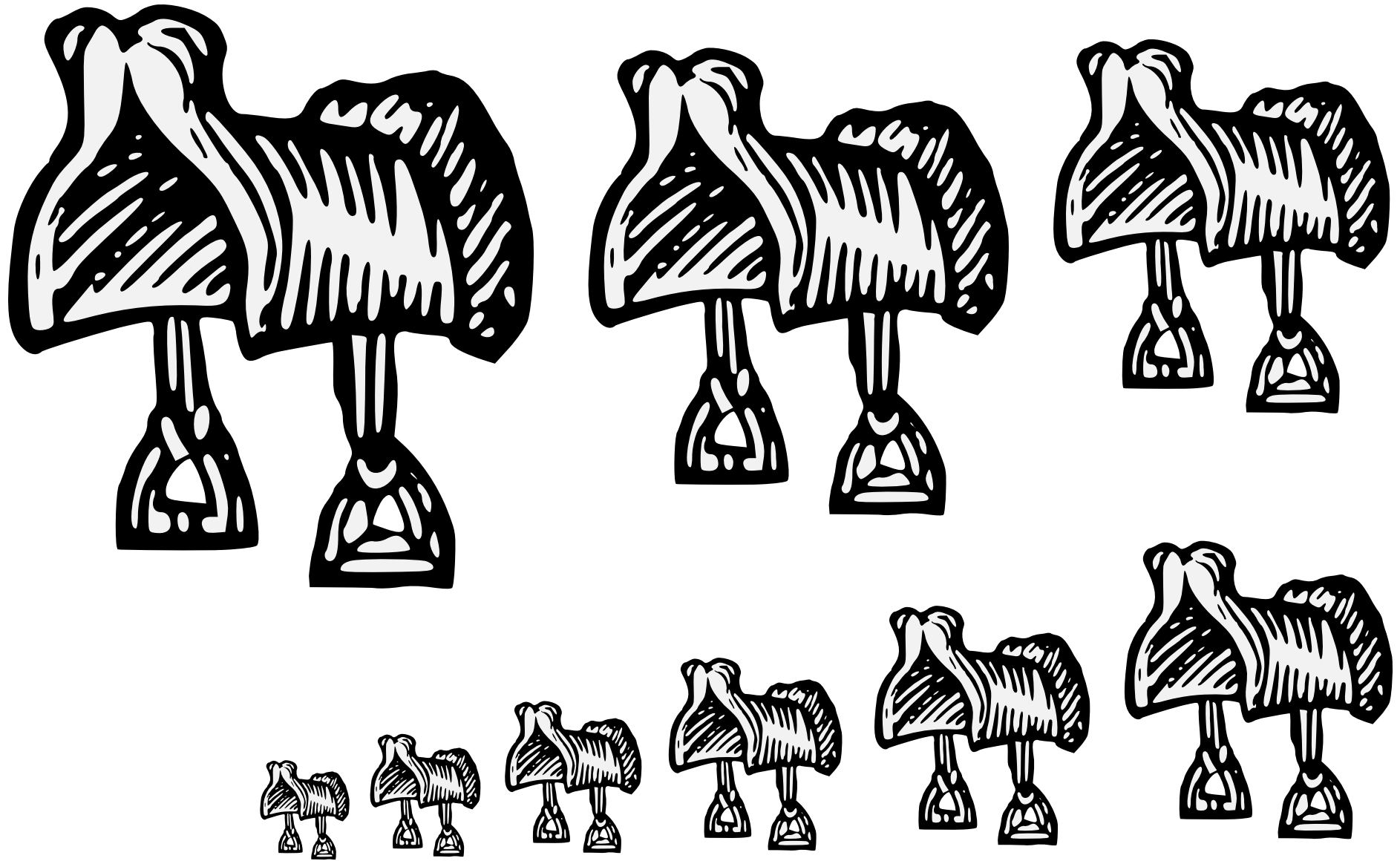

A seat that can be rested on a beast's back to make it easier to ride.

Default orientation: upright, facing dexter.

Proper coloration: brown leather.

Source: Guillim's Display of Heraldry. Artist unknown.

Saddle with Stirrups 19.126

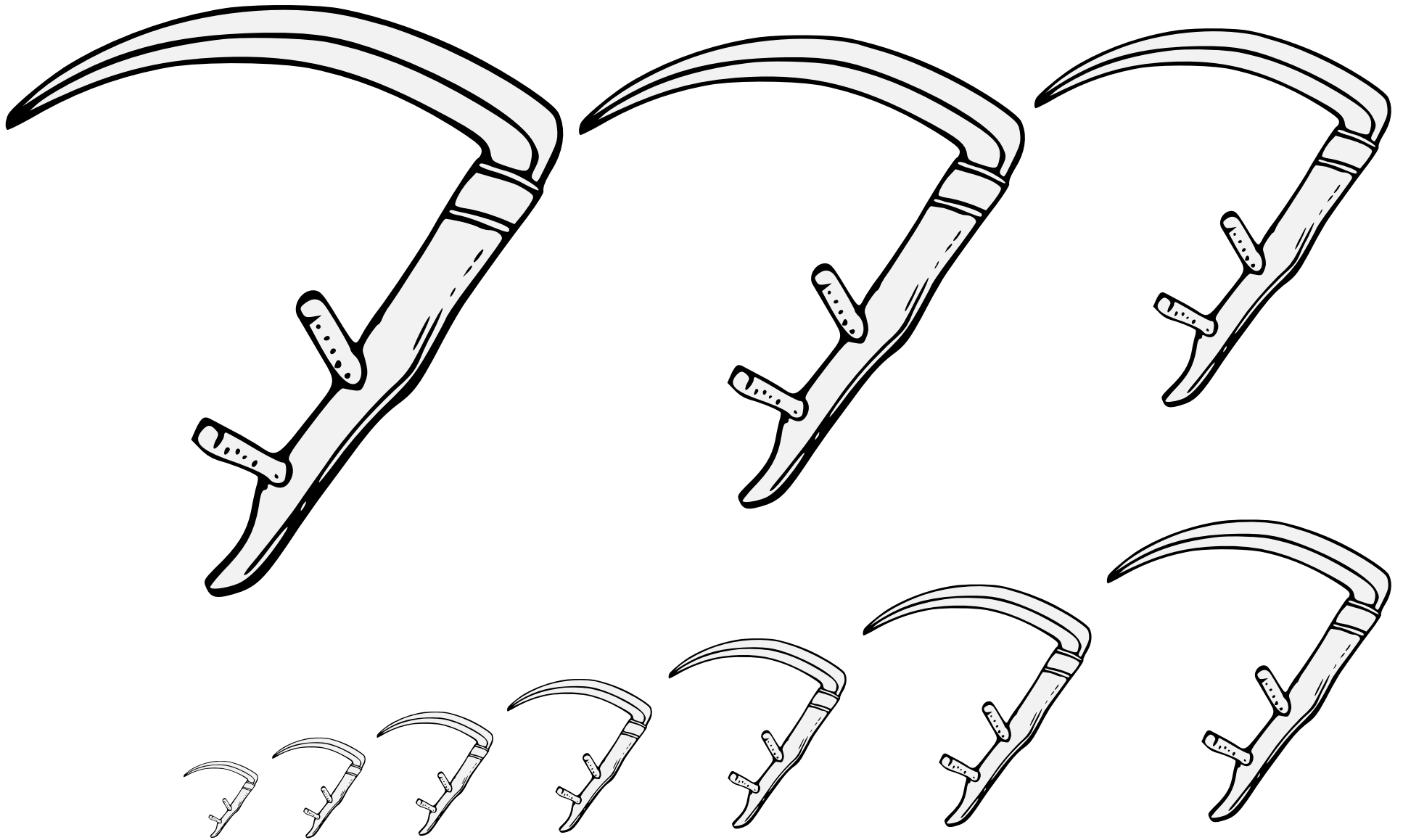

A farming implement used to harvest grain.

Default orientation: handle to base, point to dexter. No proper coloration.

Source: Banners, Standards, and Badges. Artist: Thomas Willement.

Scythe (1) 19.127

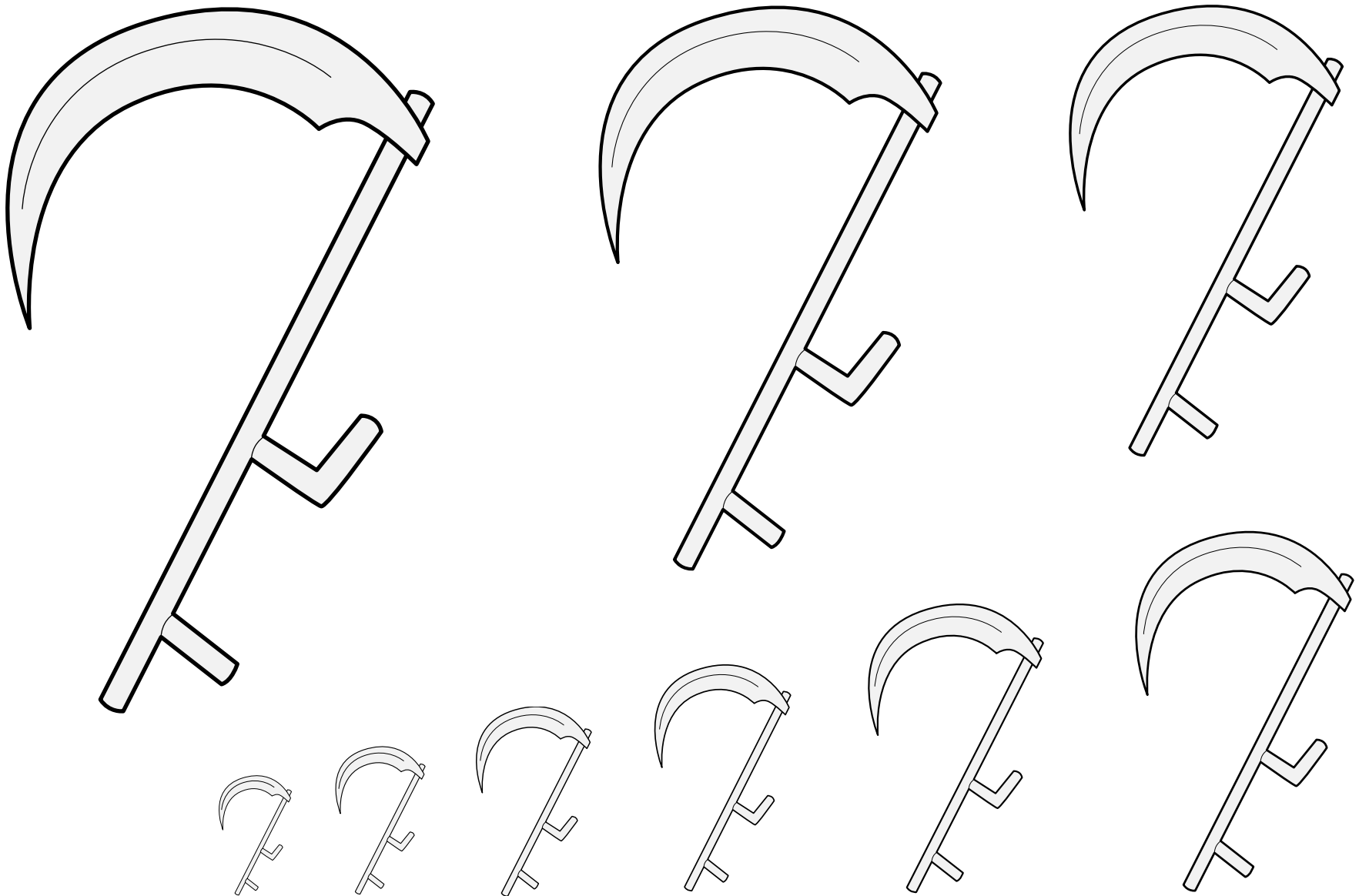

A farming implement used to harvest grain.

Default orientation: handle to base, point to dexter. No proper coloration.

Source: Opus Insignium Armorumque. Artist: Johann Weikhard von Valvasor.
Adapted by Mathghamhain Ua Ruadháin.

Scythe (2) 19.128

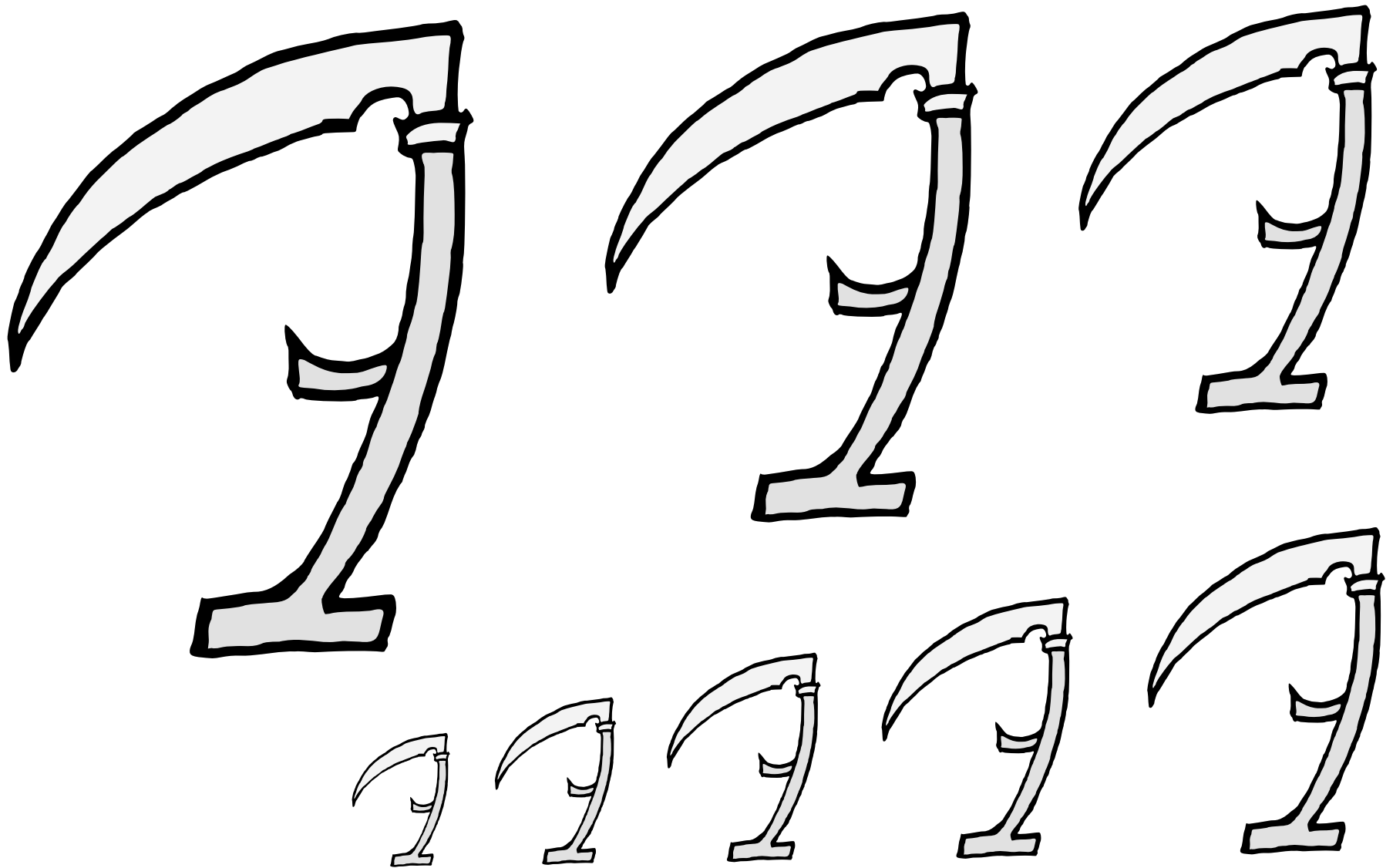

A farming implement used to harvest grain.

Default orientation: handle to base, point to dexter. No proper coloration.

Source: Aegidius Tschudi's Armorial. Artist unknown. Adapted by Iago ab Adam.

Scythe (3) 19.129

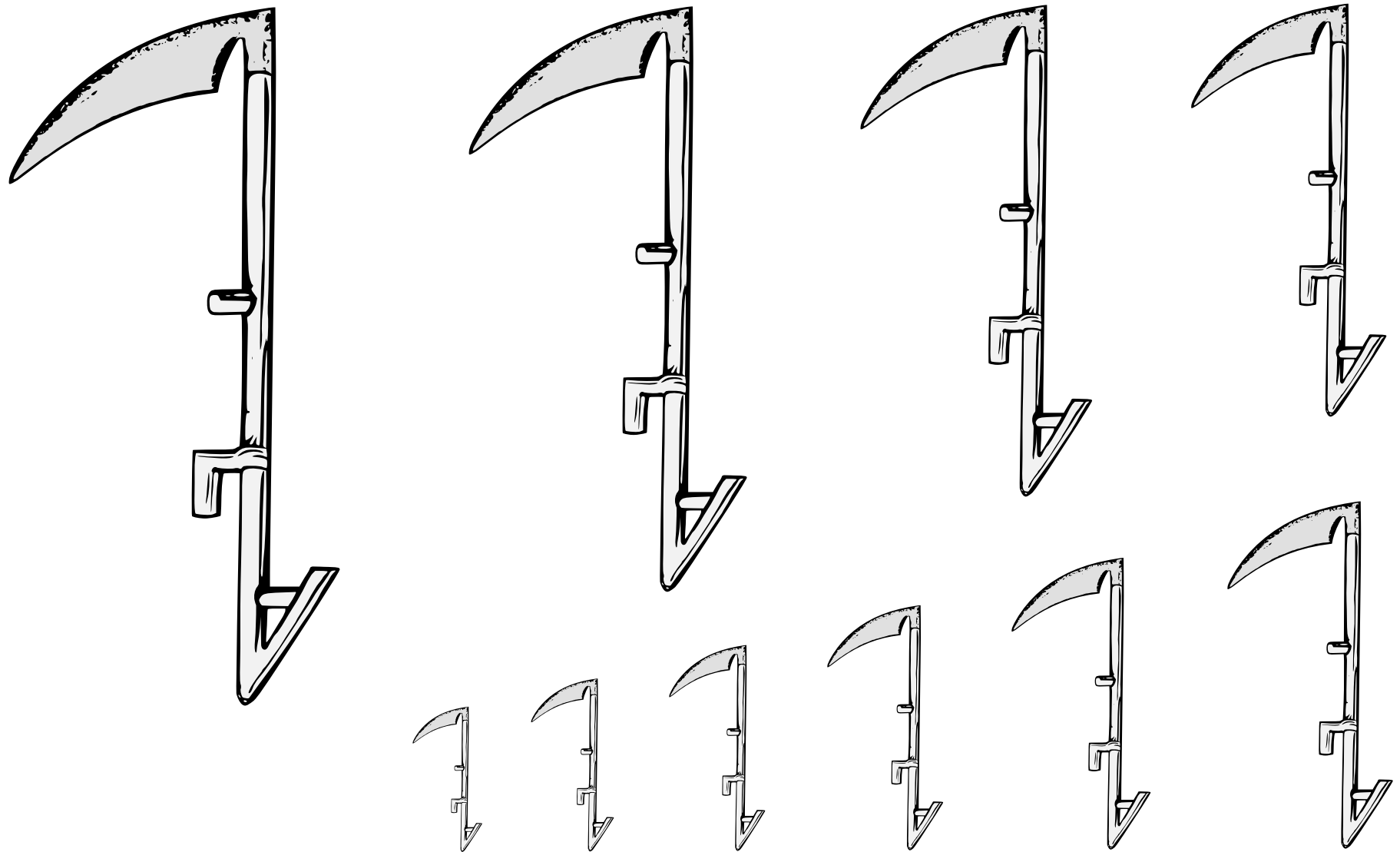

A farming implement used to harvest grain.

Default orientation: handle to base, point to dexter. No proper coloration.

Source: Wapenboek van Gent. Artist: Vander Schelden. (Volume 1, page 59.)

Scythe (4) 19.130

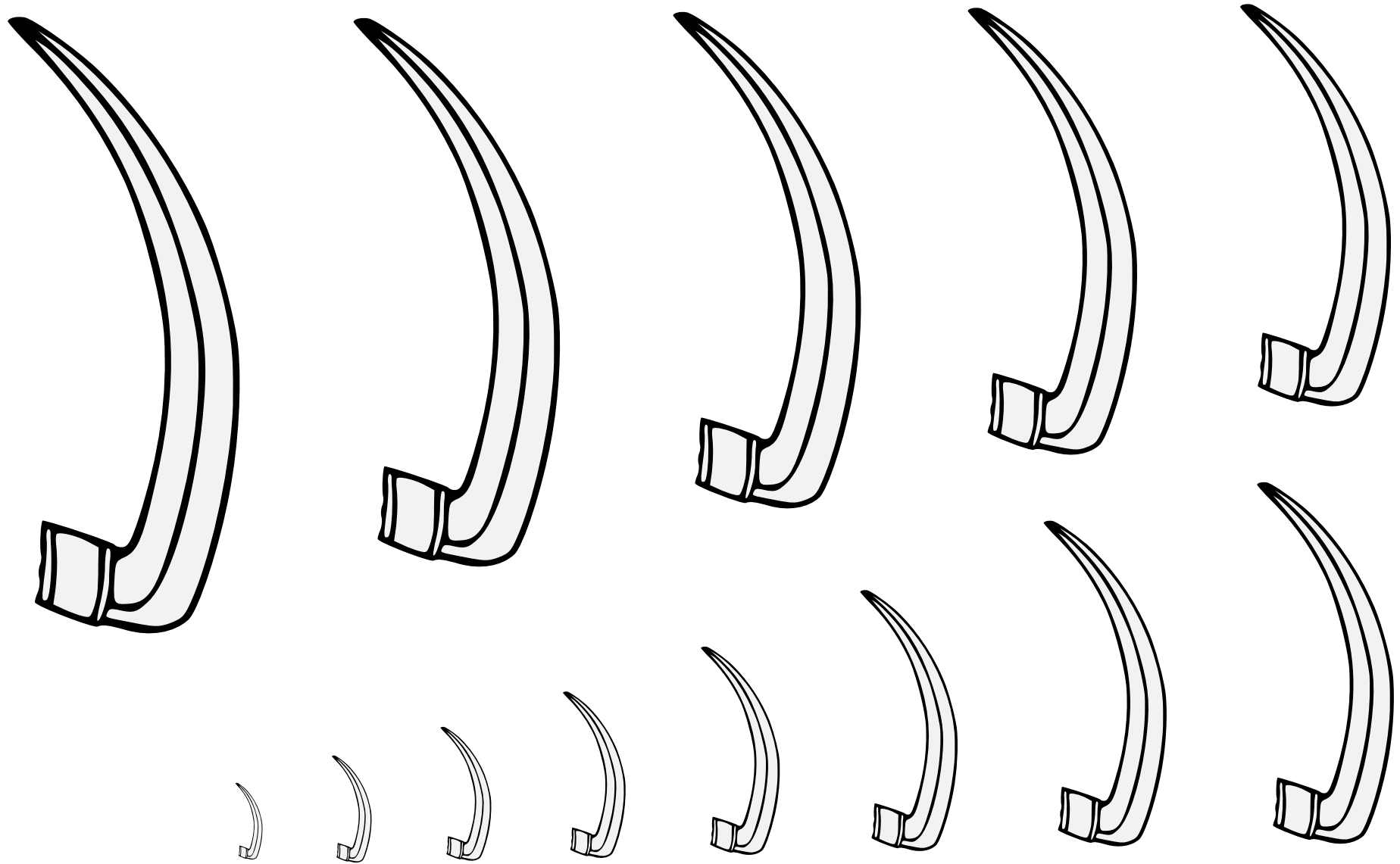

A farming implement used to harvest grain.

Default orientation: point to chief. No proper coloration.

Source: Banners, Standards, and Badges. Artist: Thomas Willement.

Scythe Blade (1) 19.131



A farming implement used to harvest grain.

Default orientation: point to chief. No proper coloration.

Source: Wappenbuch des Landkreises Hannover. Artist: Gustav Völker.

Scythe Blade (2) • 19.132

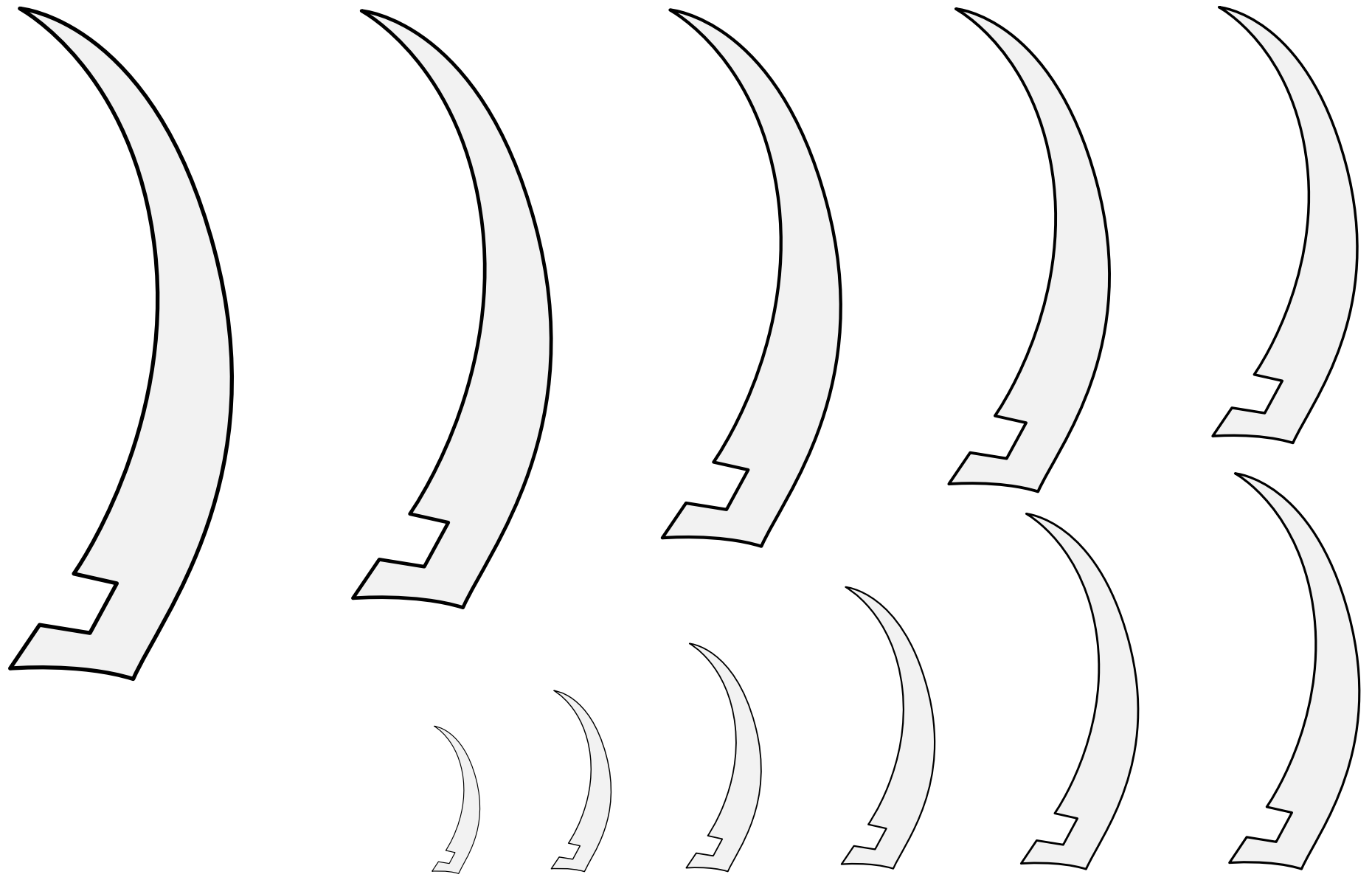

A farming implement used to harvest grain.

Default orientation: point to chief. No proper coloration.

Source: Wappenbuch der Arlberg-Bruderschaft. Artist: Vigil Raber. (Page 364.)

Scythe Blade (3) 19.133

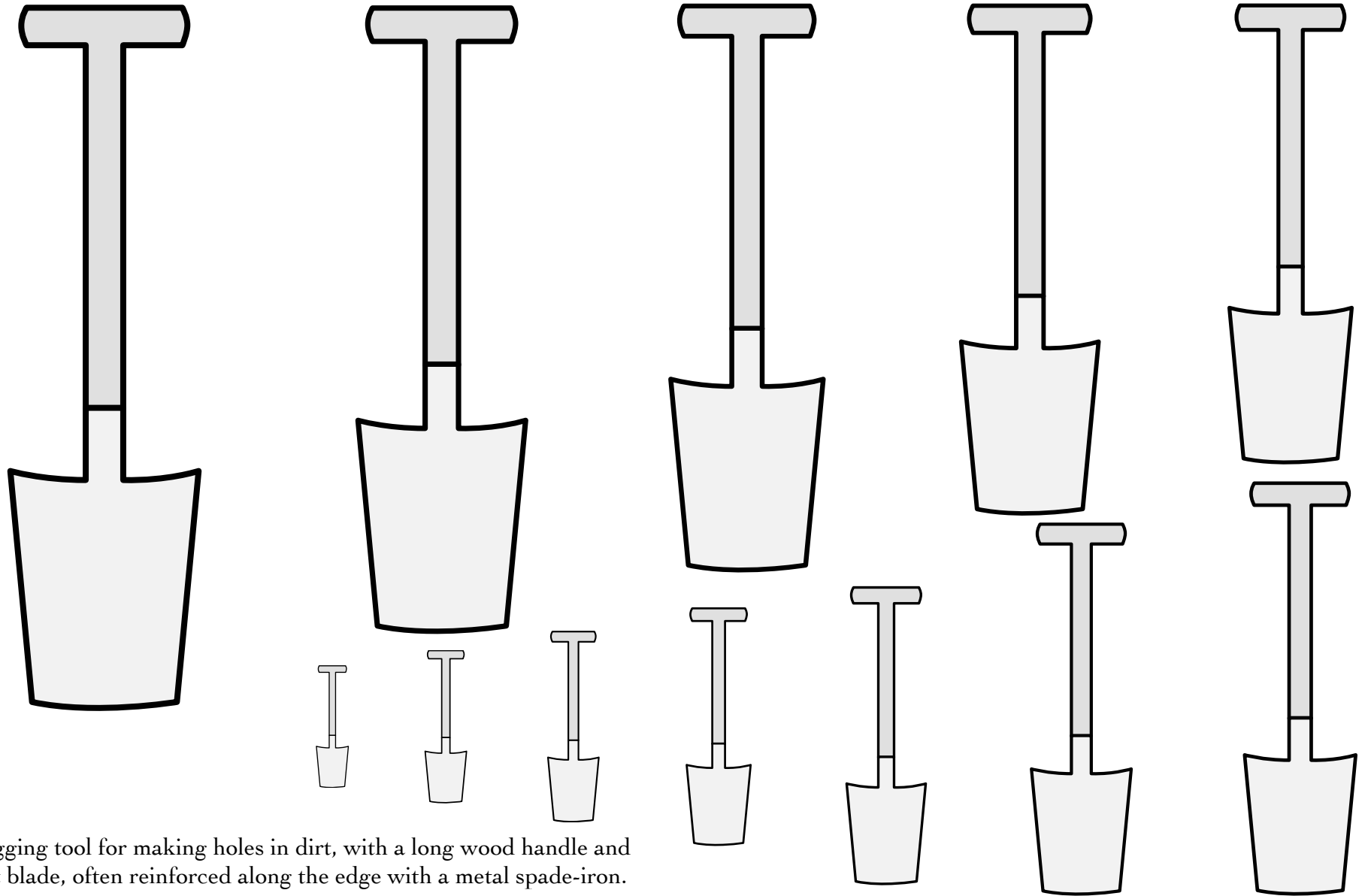

A digging tool for making holes in dirt, with a long wood handle and a flat blade, often reinforced along the edge with a metal spade-iron.

Default orientation: handle to chief. Proper coloration: brown wood.

A shovel is similar to a spade, but optimized for scooping, and differentiated by its square blade.

Source: Viking Answer Lady SVG Images For Heralds. Artist: Gunnvôr silfráhrarr.
Adapted by Mathghamhain Ua Ruadháin.

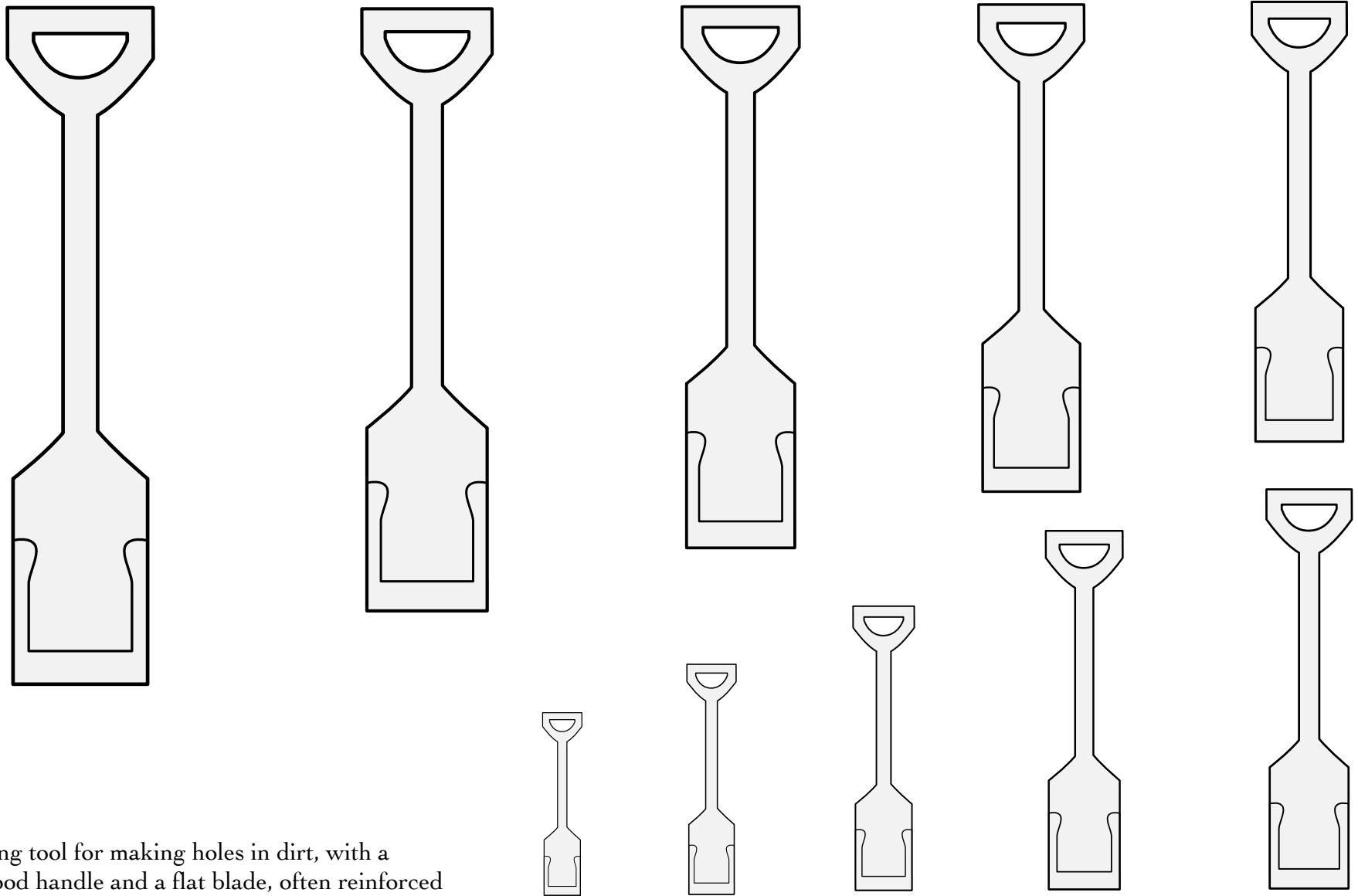

A digging tool for making holes in dirt, with a long wood handle and a flat blade, often reinforced along the edge with a metal spade-iron.

Default orientation: handle to chief. Proper coloration: brown wood.

A shovel is similar to a spade, but optimized for scooping, and differentiated by its square blade.

Source: Fenwick Roll. Artist unknown. Adapted by Mathghamhain Ua Ruadháin.

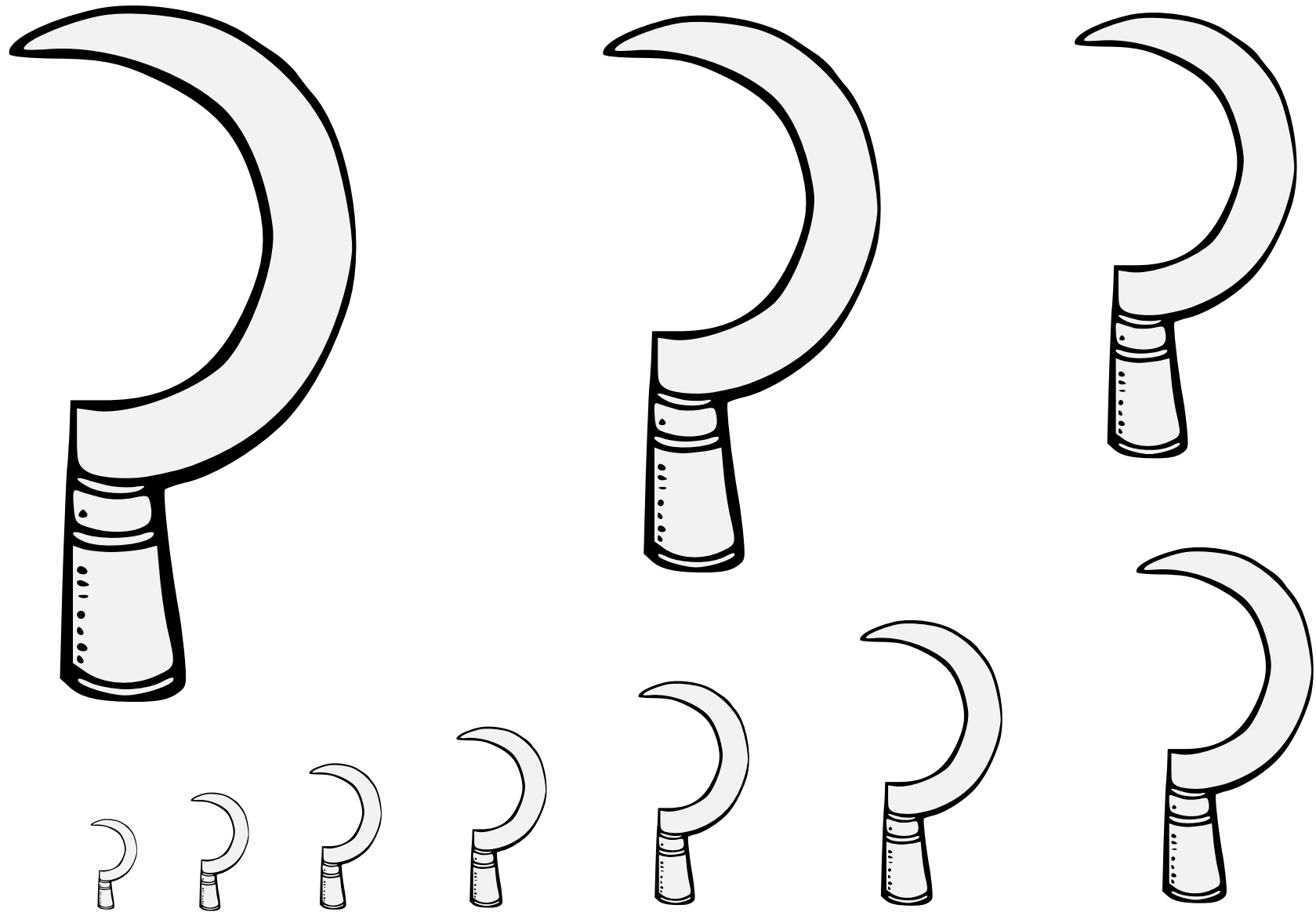

A farming implement used to harvest grain.

Default orientation: handle to base, point to dexter. No proper coloration.

Source: Banners, Standards, and Badges. Artist: Thomas Willement.

Sickle (1) 19.136

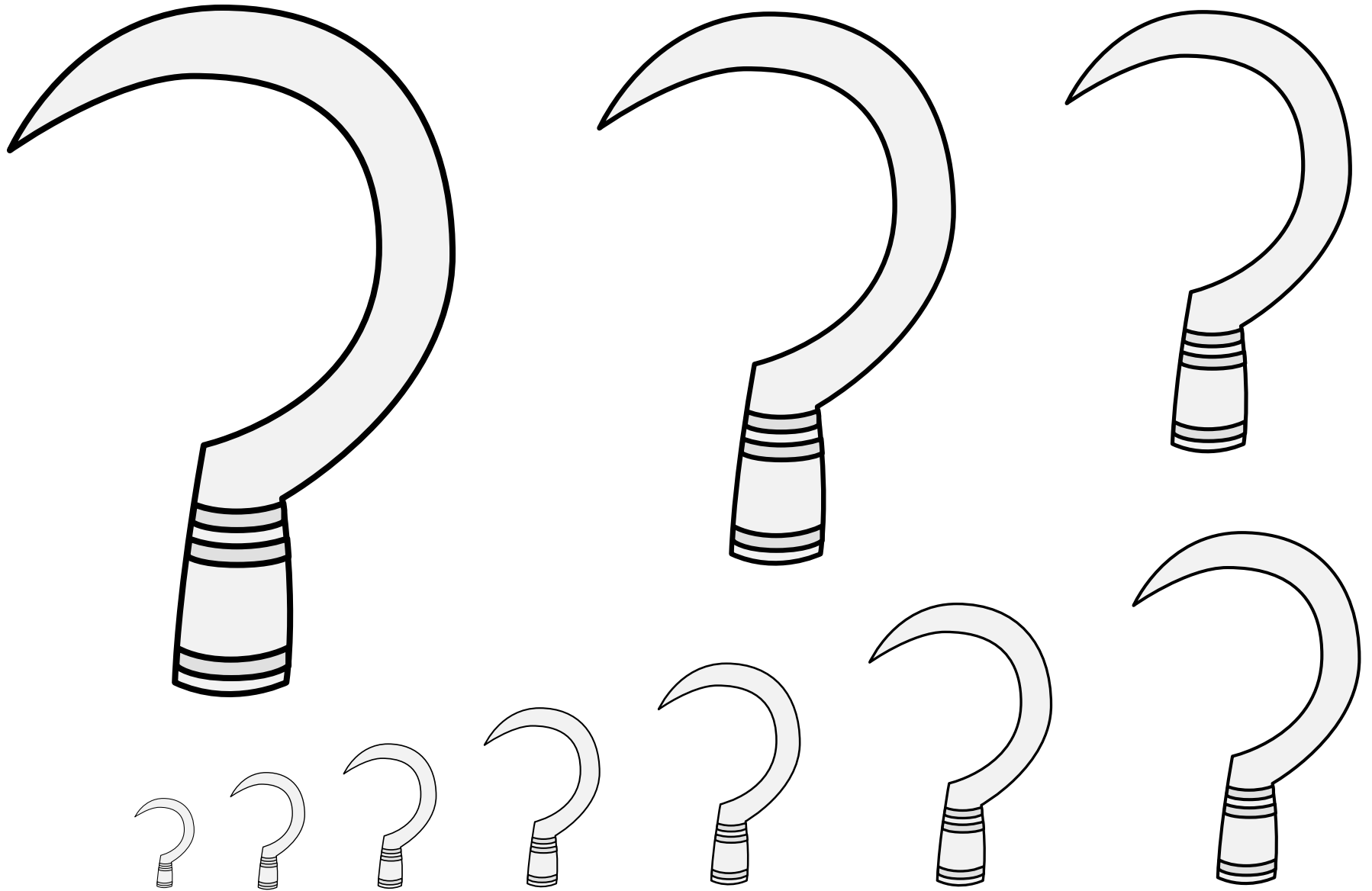

A farming implement used to harvest grain.

Default orientation: handle to base, point to dexter. No proper coloration.

Source: Banners, Standards, and Badges. Artist: Thomas Willement.

Sickle (2) 19.137

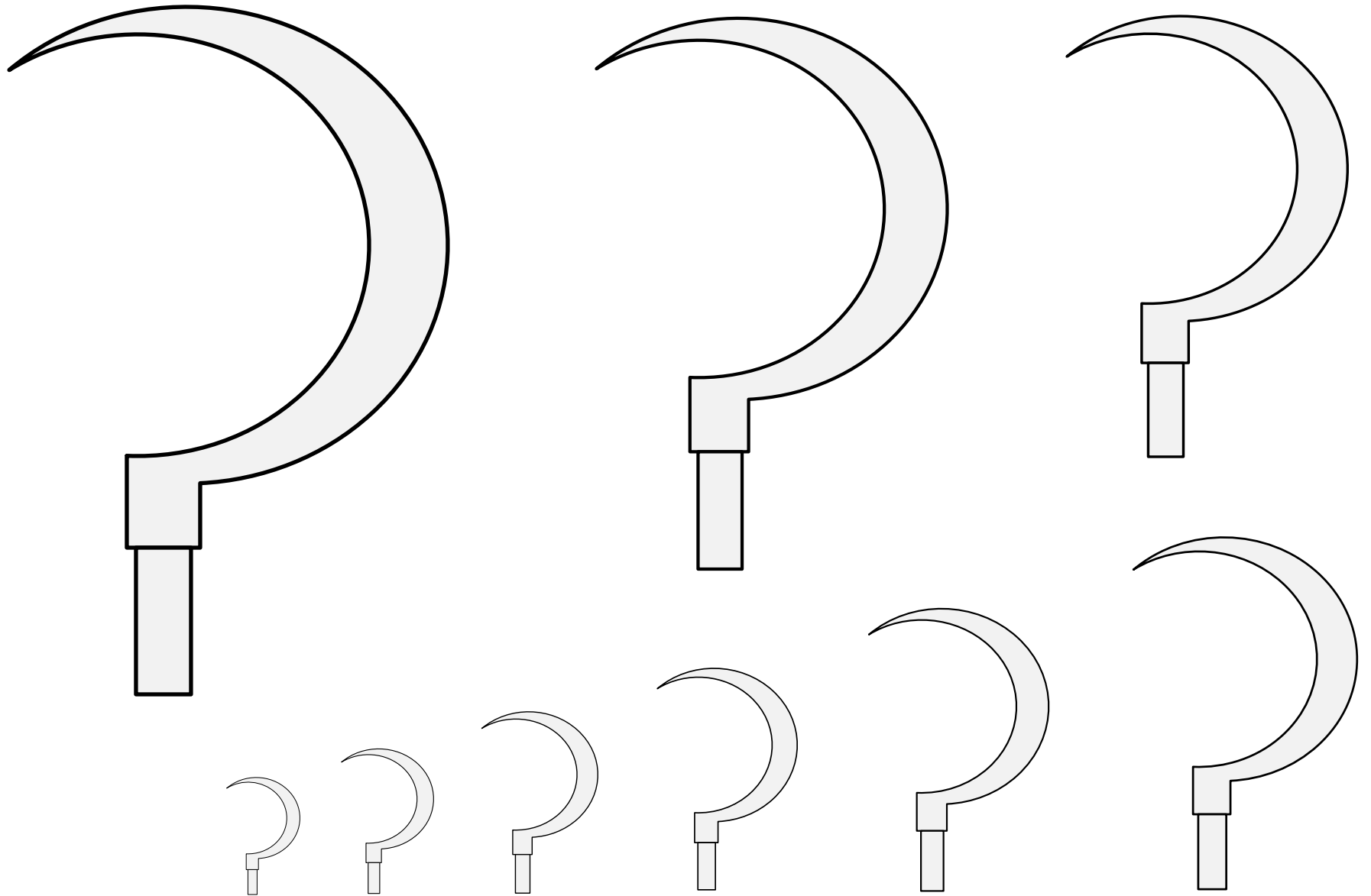

A farming implement used to harvest grain.

Default orientation: handle to base, point to dexter. No proper coloration.

Source: A Glossary of Terms Used in Heraldry. Artist: James or Irene Parker.
Adapted by Mathghamhain Ua Ruadháin.

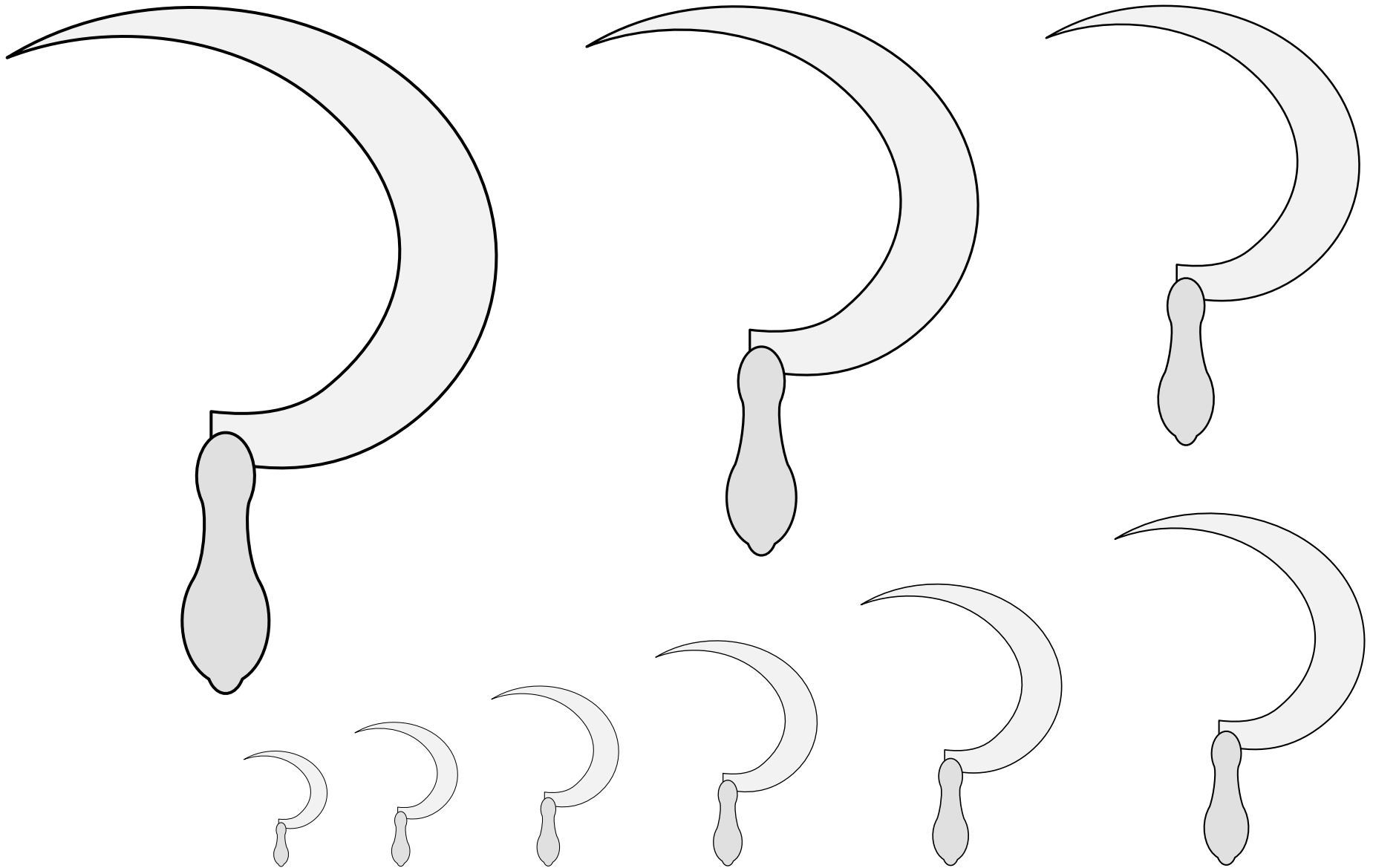

A farming implement used to harvest grain.

Default orientation: handle to base, point to dexter. No proper coloration.

Sickle (4) 19.139

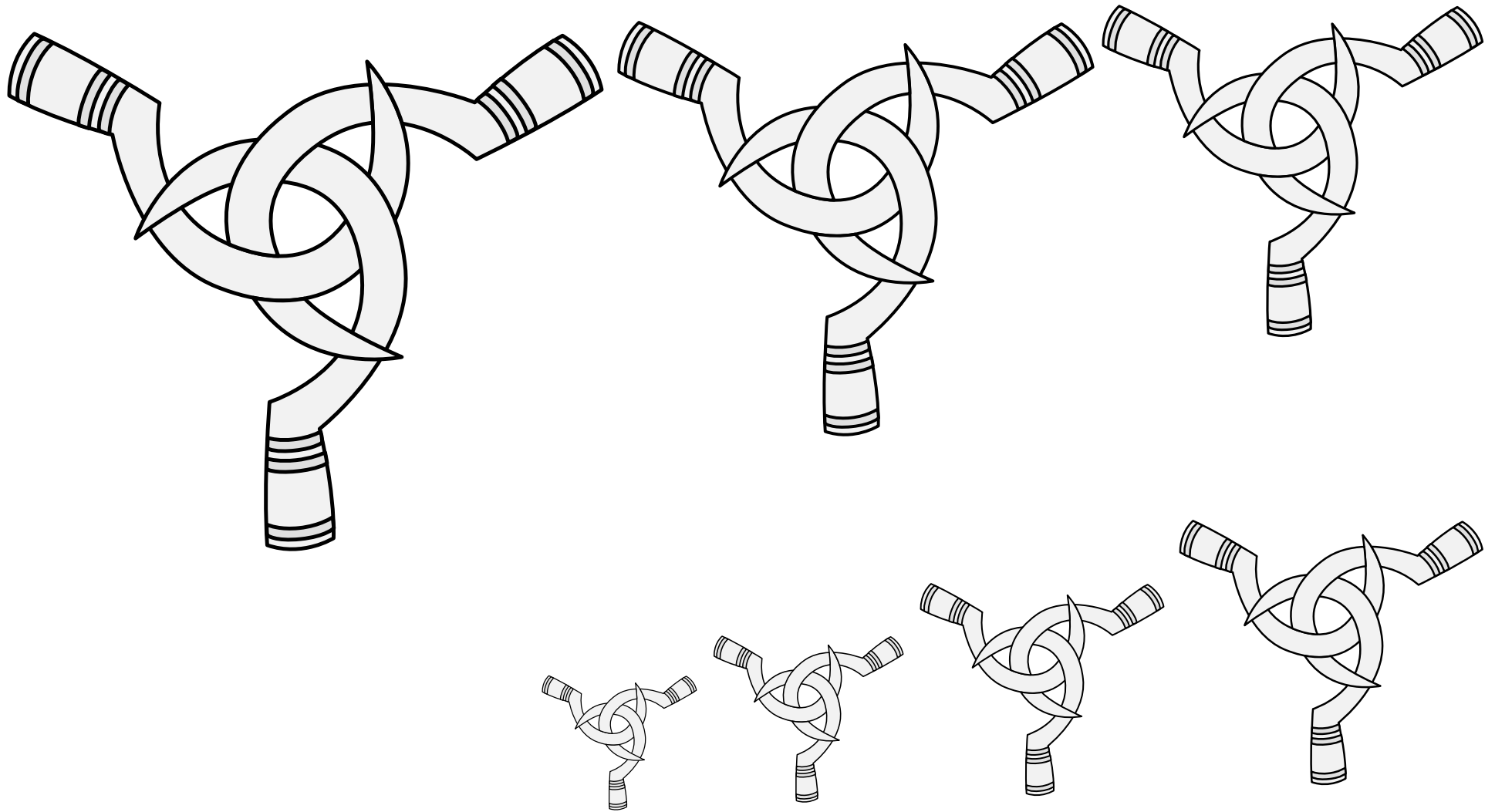

A farming implement used to harvest grain.

Default orientation: handle to base, point to dexter. No proper coloration.

Source: Banners, Standards, and Badges.

Artist: Thomas Willement.

Sickles, Three, Interlaced 19.140

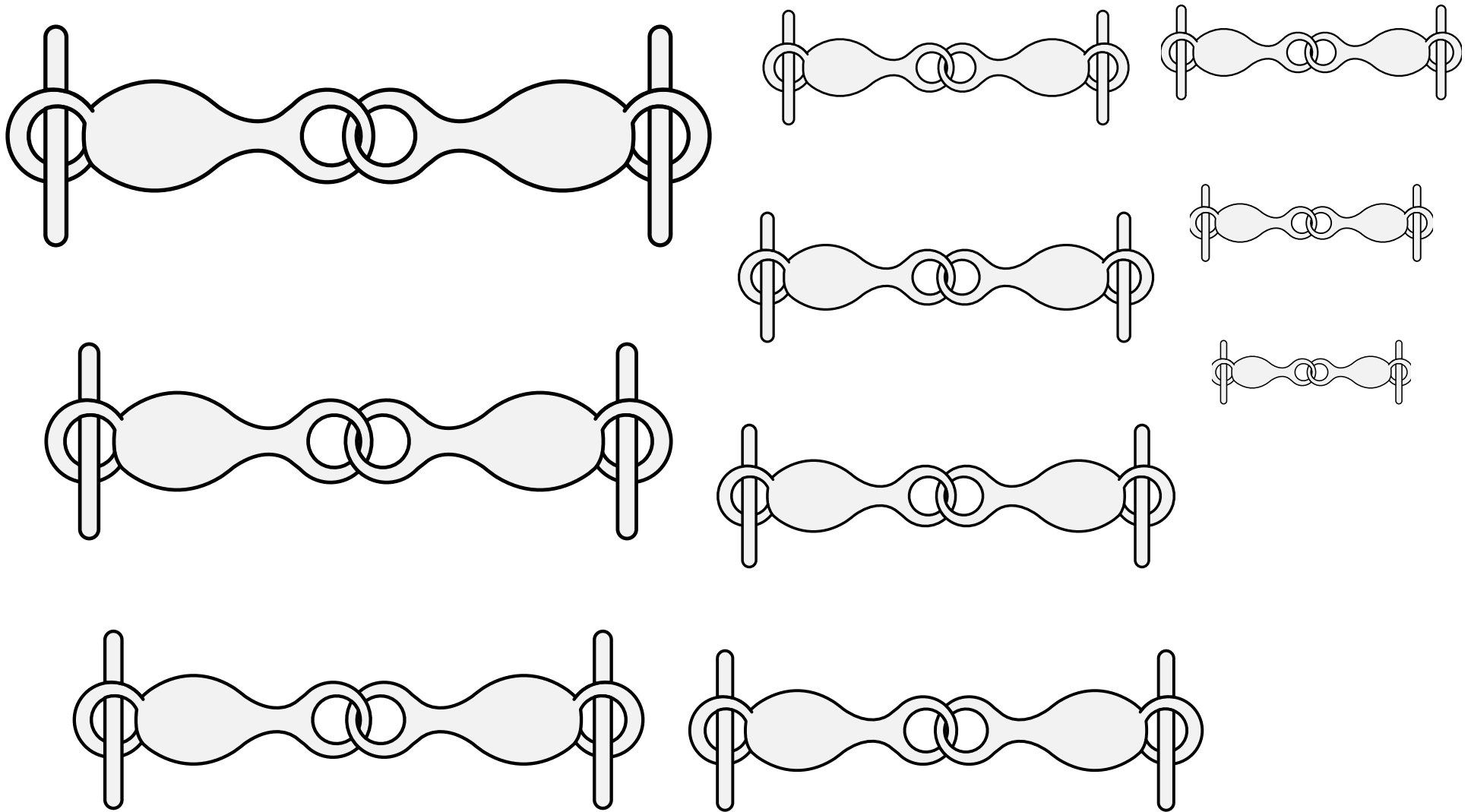

A bar placed in a horse's mouth to direct it while riding.

Default orientation: fesswise. No proper coloration.

Source: Wappenbuch Süddeutschland. Artist unknown.
(Arms of Kasattel, folio 237v.)

Snaffle-Bit (1) 19.141

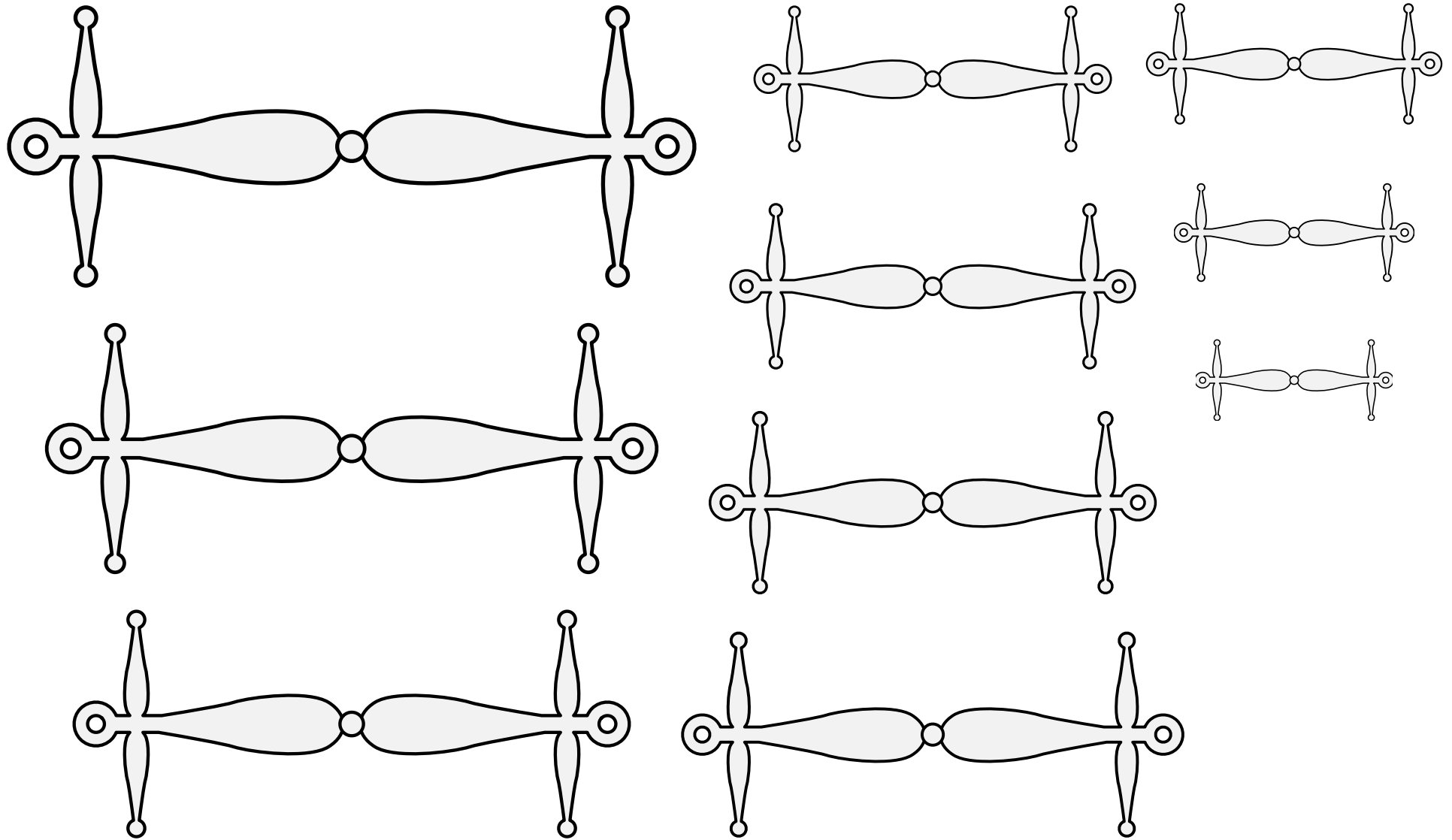

A bar placed in a horse's mouth to direct it while riding.

Default orientation: fesswise. No proper coloration.

Source: A Glossary of Terms Used in Heraldry. Artist: James or Irene Parker.

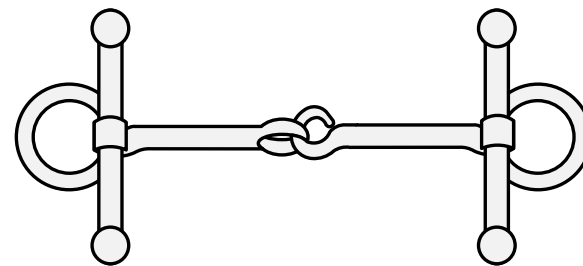
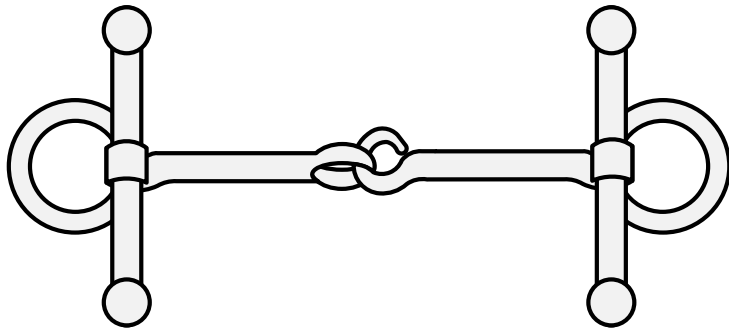
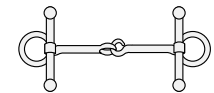
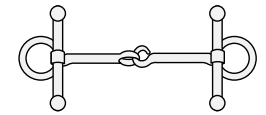
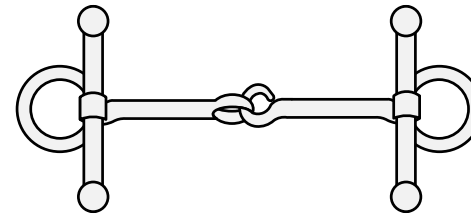
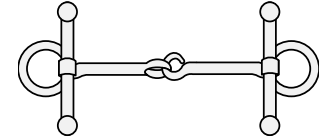
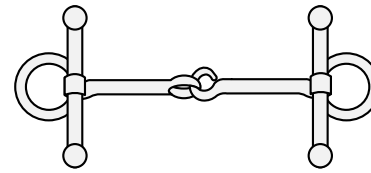
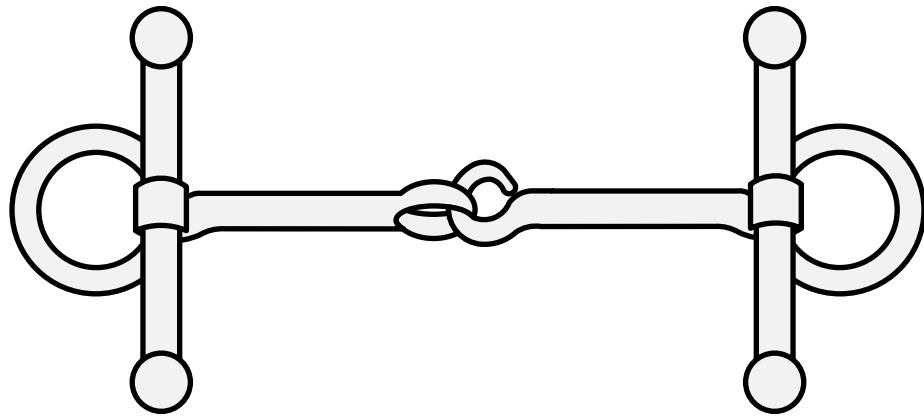

A bar placed in a horse's mouth to direct it while riding.

Default orientation: fesswise. No proper coloration.

Source: Viking Answer Lady SVG Images For Heralds. Artist: Gunnvôr silfráhr.

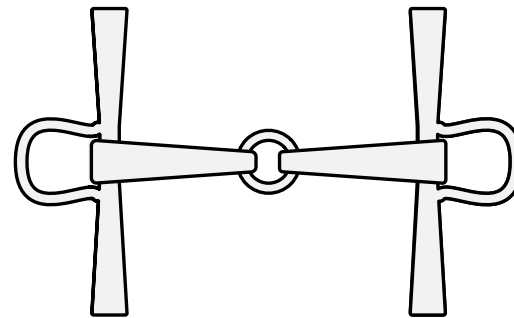
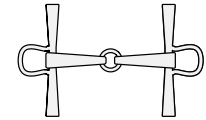
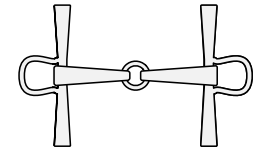
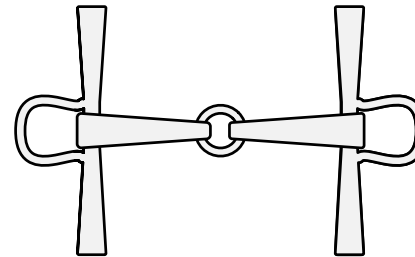
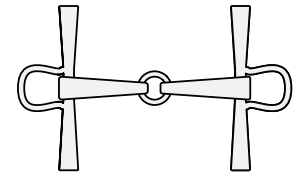
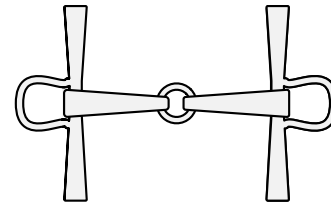
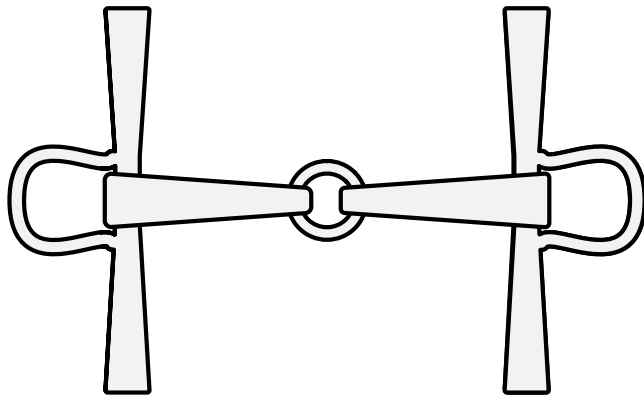
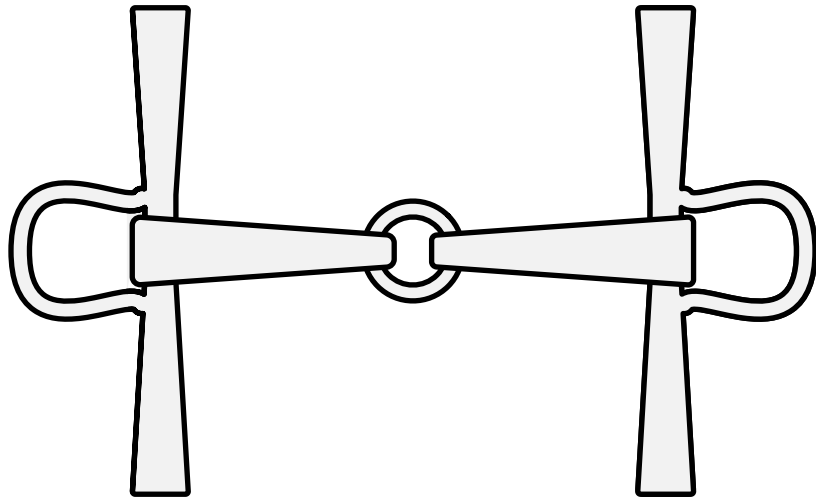

A bar placed in a horse's mouth to direct it while riding.
Default orientation: fesswise. No proper coloration.
Adapted from photographs of a period artifact.

Snaffle-Bit (4) 19.144

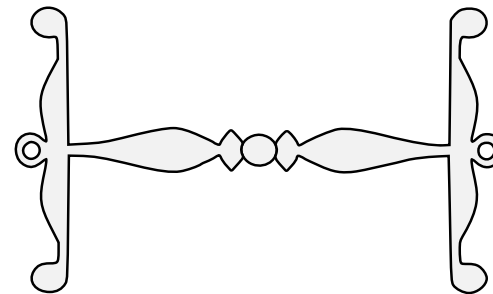
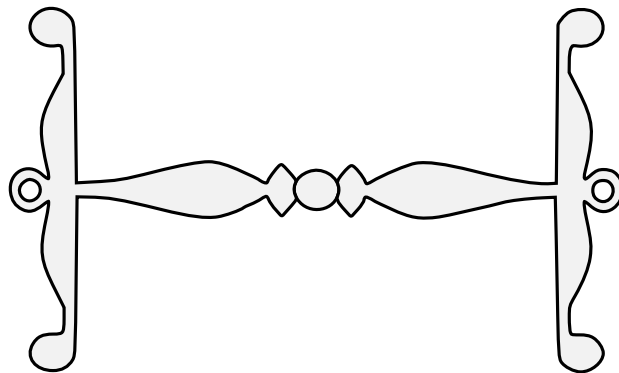
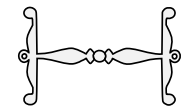
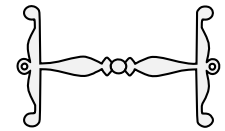
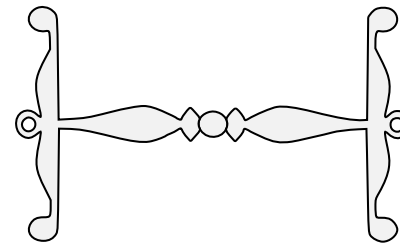
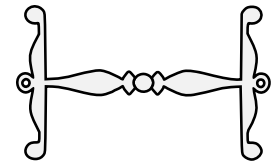
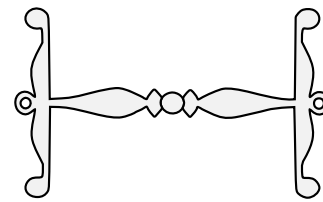
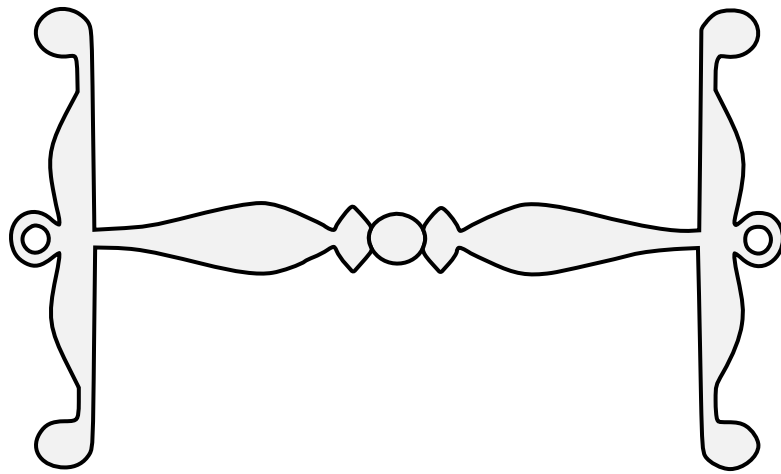

A bar placed in a horse's mouth to direct it while riding.

Default orientation: fesswise. No proper coloration.

Artist: Jessimond of Emerickeskepe.

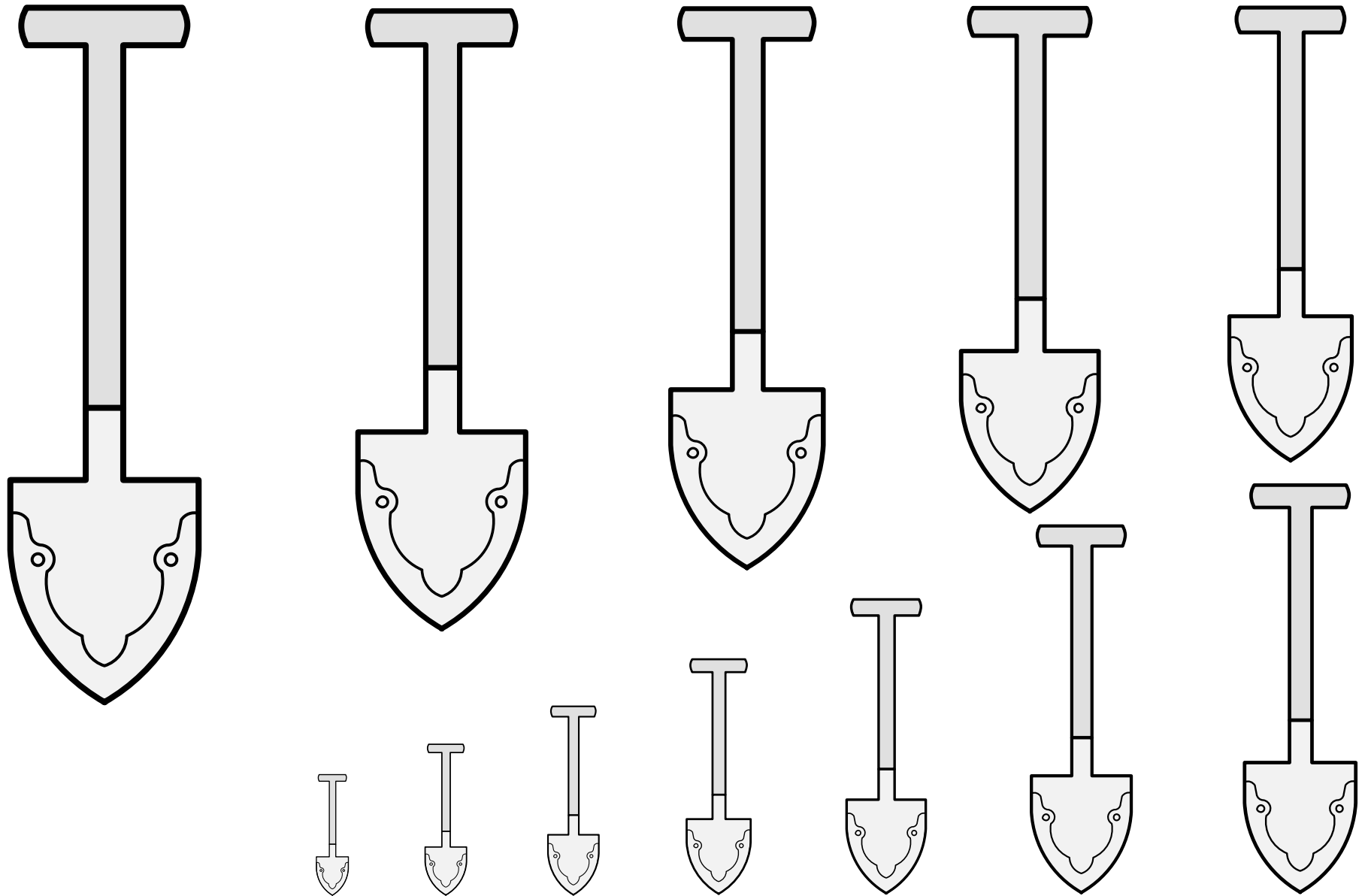

A digging tool for making holes in dirt, with a long wood handle and a flat blade, often reinforced along the edge with a metal spade-iron.

Default orientation: handle to chief. Proper coloration: brown wood.

Source: Viking Answer Lady SVG Images For Heraldists. Artist: Gunnvôr silfráhr.

Spade (1) 19.146

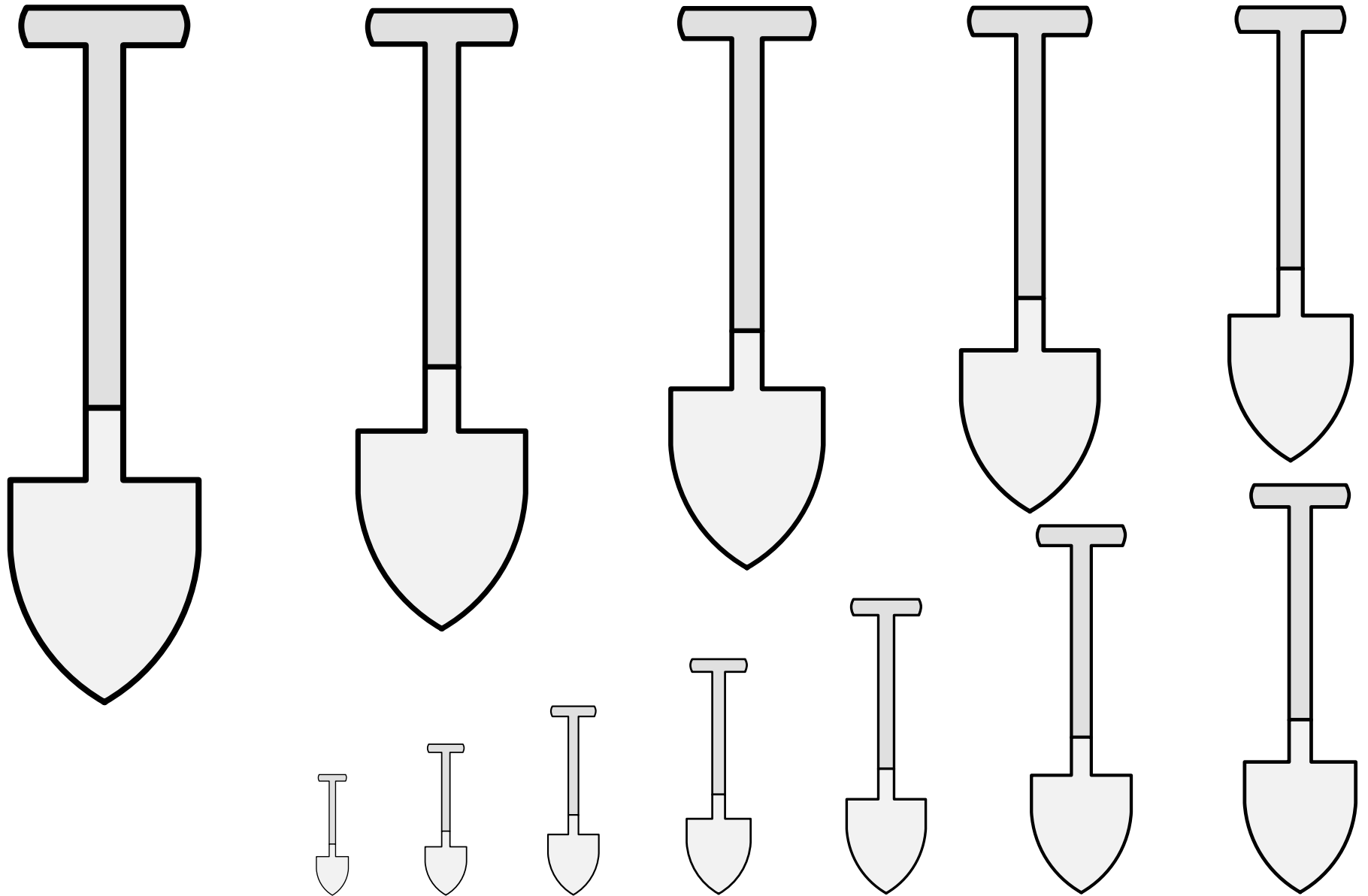

A digging tool for making holes in dirt, with a long wood handle and a flat blade, often reinforced along the edge with a metal spade-iron.

Default orientation: handle to chief. Proper coloration: brown wood.

Source: Viking Answer Lady SVG Images For Heralds. Artist: Gunnvôr silfrahárr.

Adapted by Mathghamhain Ua Ruadháin.

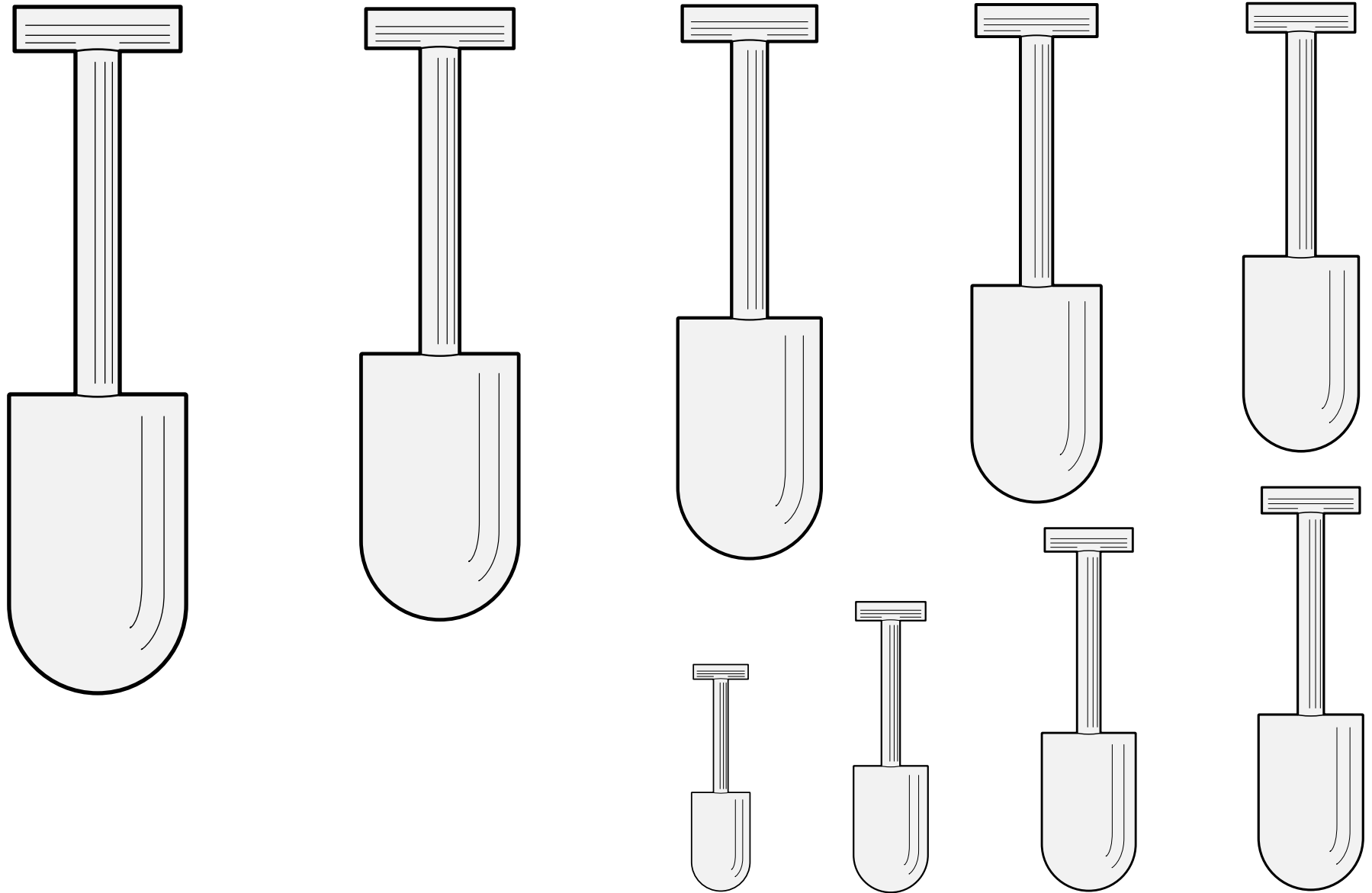

A digging tool for making holes in dirt, with a long wood handle and a flat blade, often reinforced along the edge with a metal spade-iron.

Default orientation: handle to chief. Proper coloration: brown wood.

Source: Opus Insignium Armorumque. (Folio 120.) Artist: Johann Weikhard von Valvasor.
Adapted by Mathghamhain Ua Ruadháin.

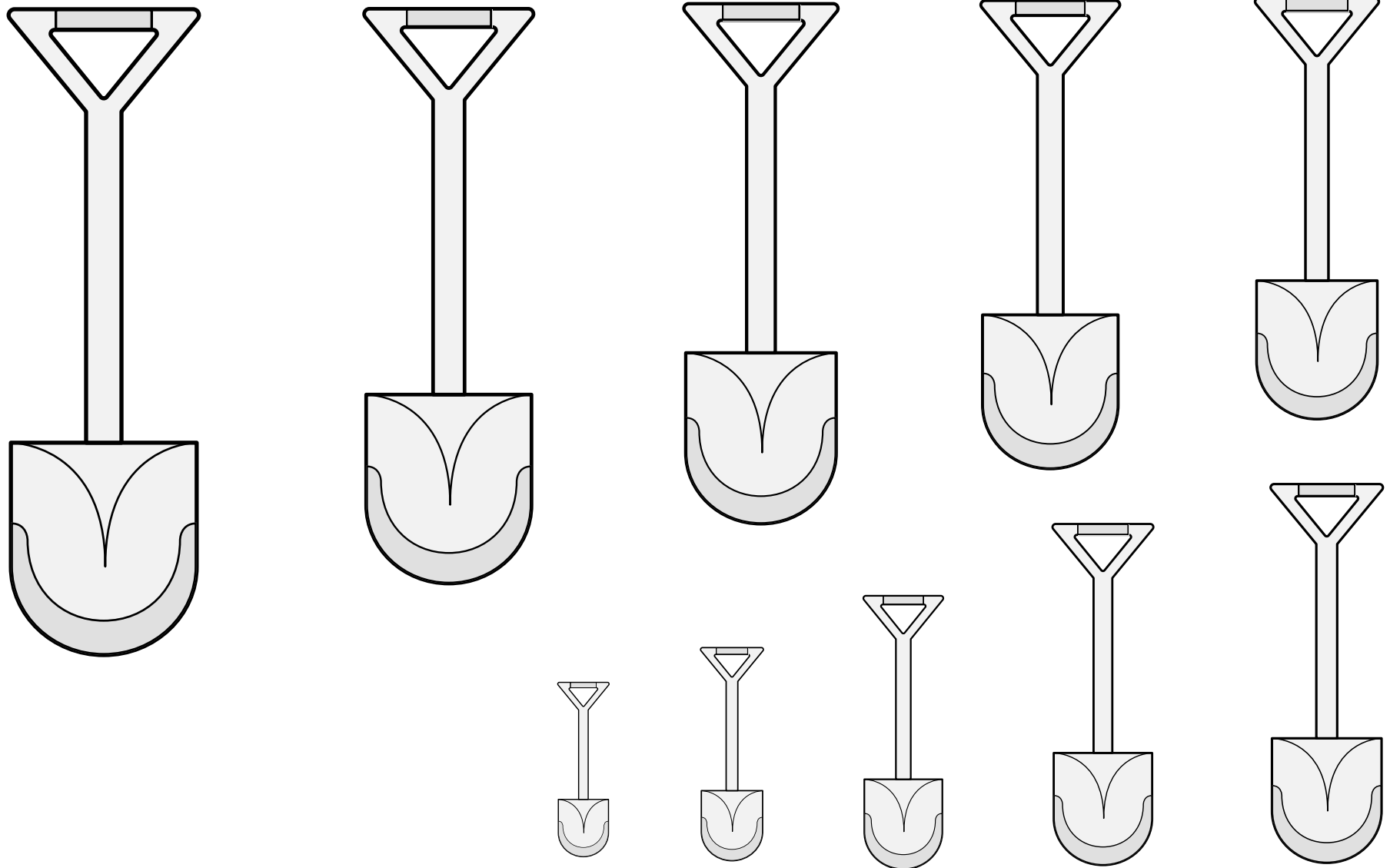

A digging tool for making holes in dirt, with a long wood handle and a flat blade, often reinforced along the edge with a metal spade-iron.

Default orientation: handle to chief. Proper coloration: brown wood.

Source: Siebmacher's Wappenbuch of 1605. Artist: Johann Siebmacher.
(Folio 176, arms of Schwanbergk.) Adapted by Mathghamhain Ua Ruadháin.

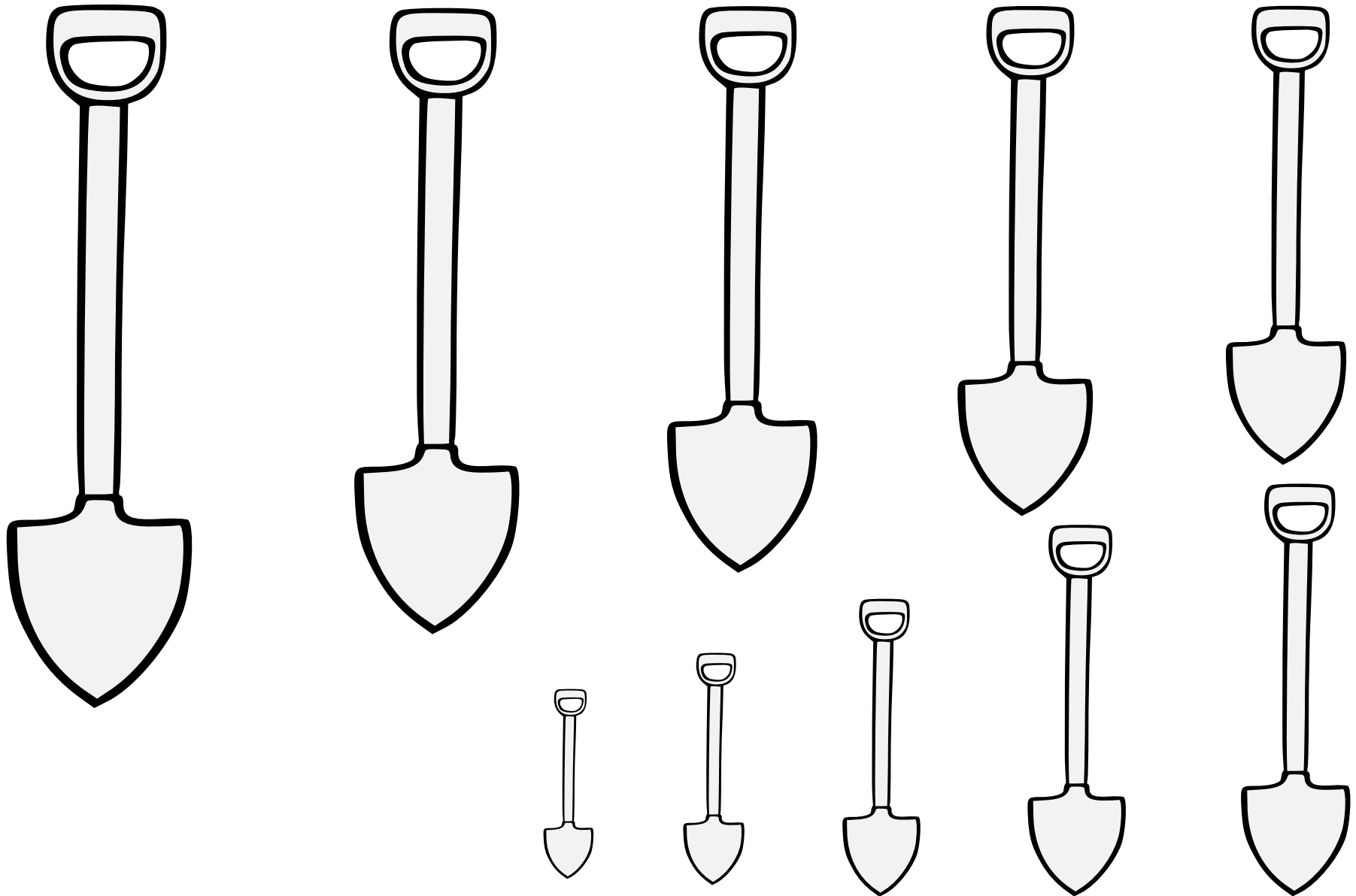

A digging tool for making holes in dirt, with a long wood handle and a flat blade, often reinforced along the edge with a metal spade-iron.

Default orientation: handle to chief. Proper coloration: brown wood.

Source: Pennsic Traceable Art. Artist unknown.

Spade (5) • 19.150

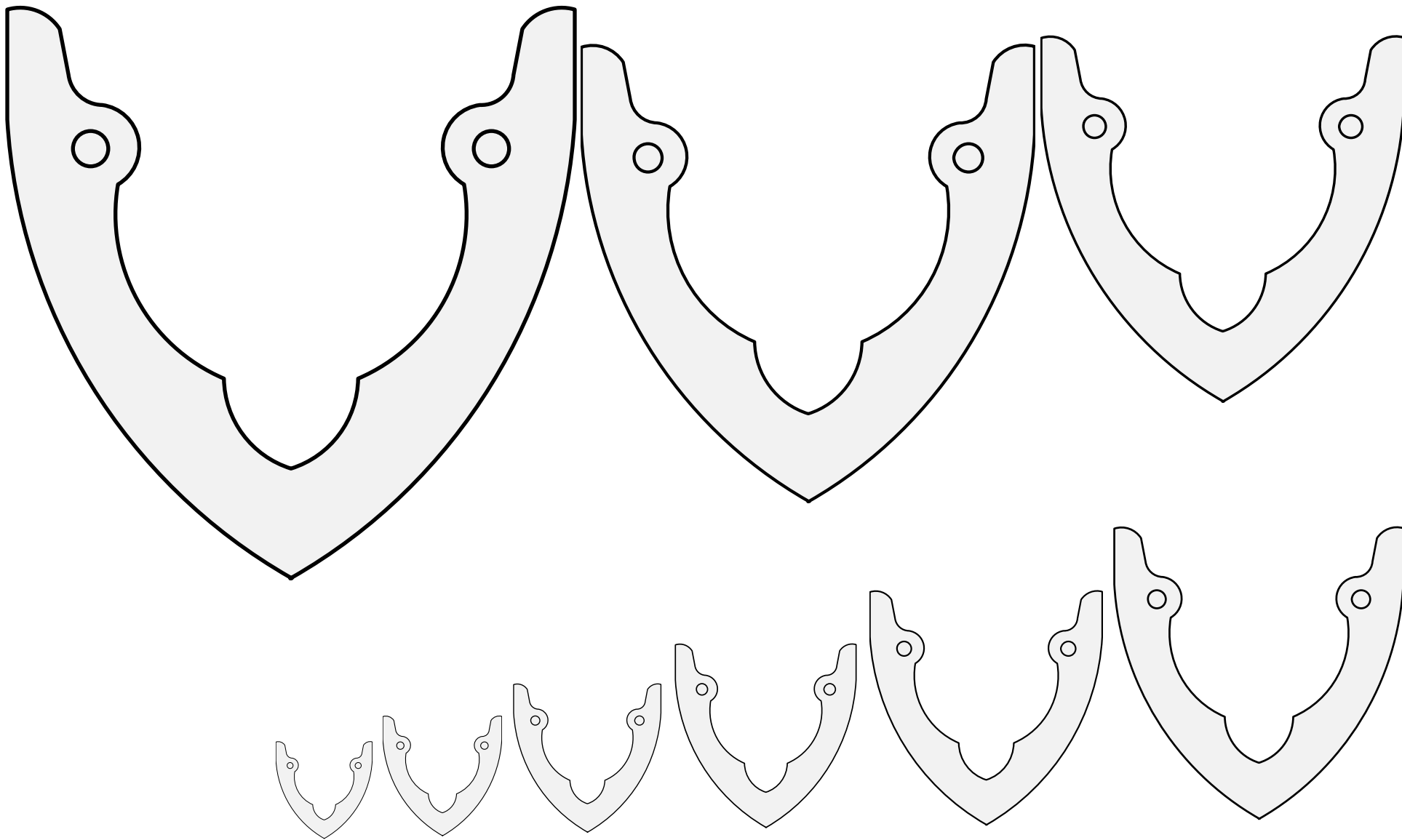

A reinforcing edge applied to a spade.

Default orientation: point to base. No proper coloration.

Source: Viking Answer Lady SVG Images For Heraldists. Artist: Gunnvör silfrhárr.
Adapted by Mathghamhain Ua Ruadháin.

Spade-Iron 19.151

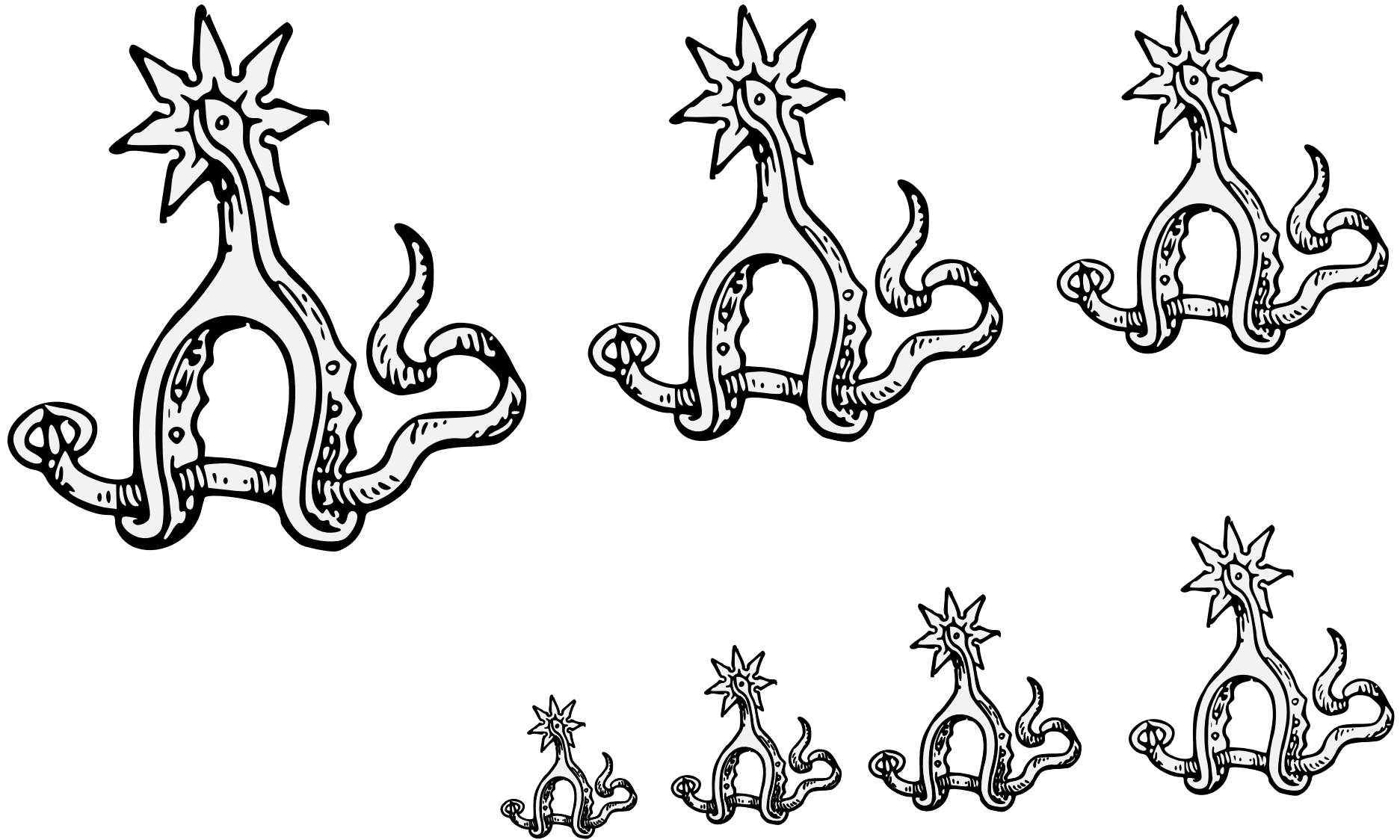

A boot attachment for prodding a horse.

May be drawn without the leather strap.

Default orientation: rowel to chief.

Source: A Complete Guide to Heraldry. Artist: Graham Johnston.

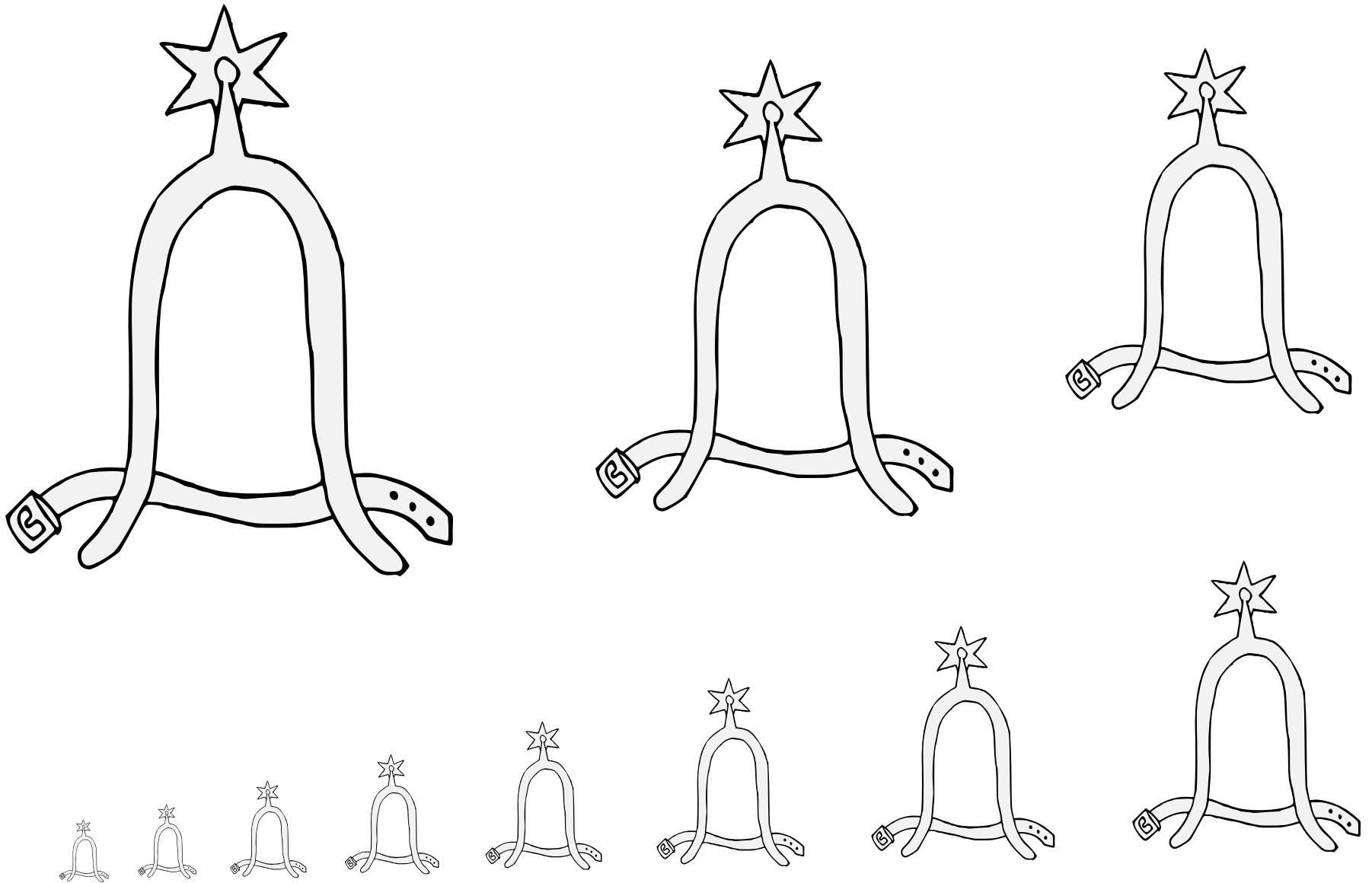

A boot attachment for prodding a horse.

May be drawn without the leather strap.

Default orientation: rowel to chief.

Source: Pennsic Traceable Art. Artist unknown.

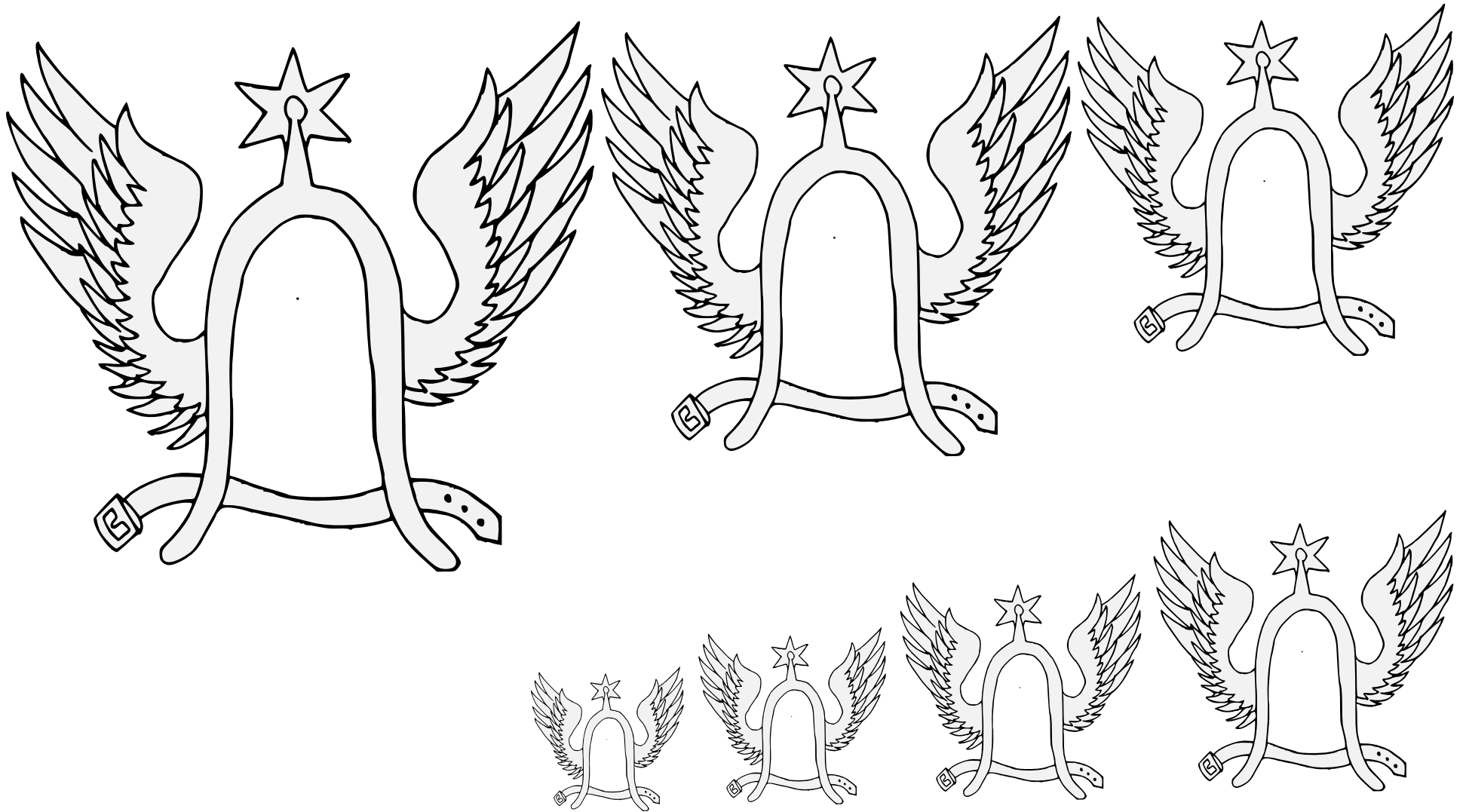

A boot attachment for prodding a horse.
May be drawn without the leather strap.
Default orientation: rowel to chief.
Source: Pennsic Traceable Art. Artist unknown.

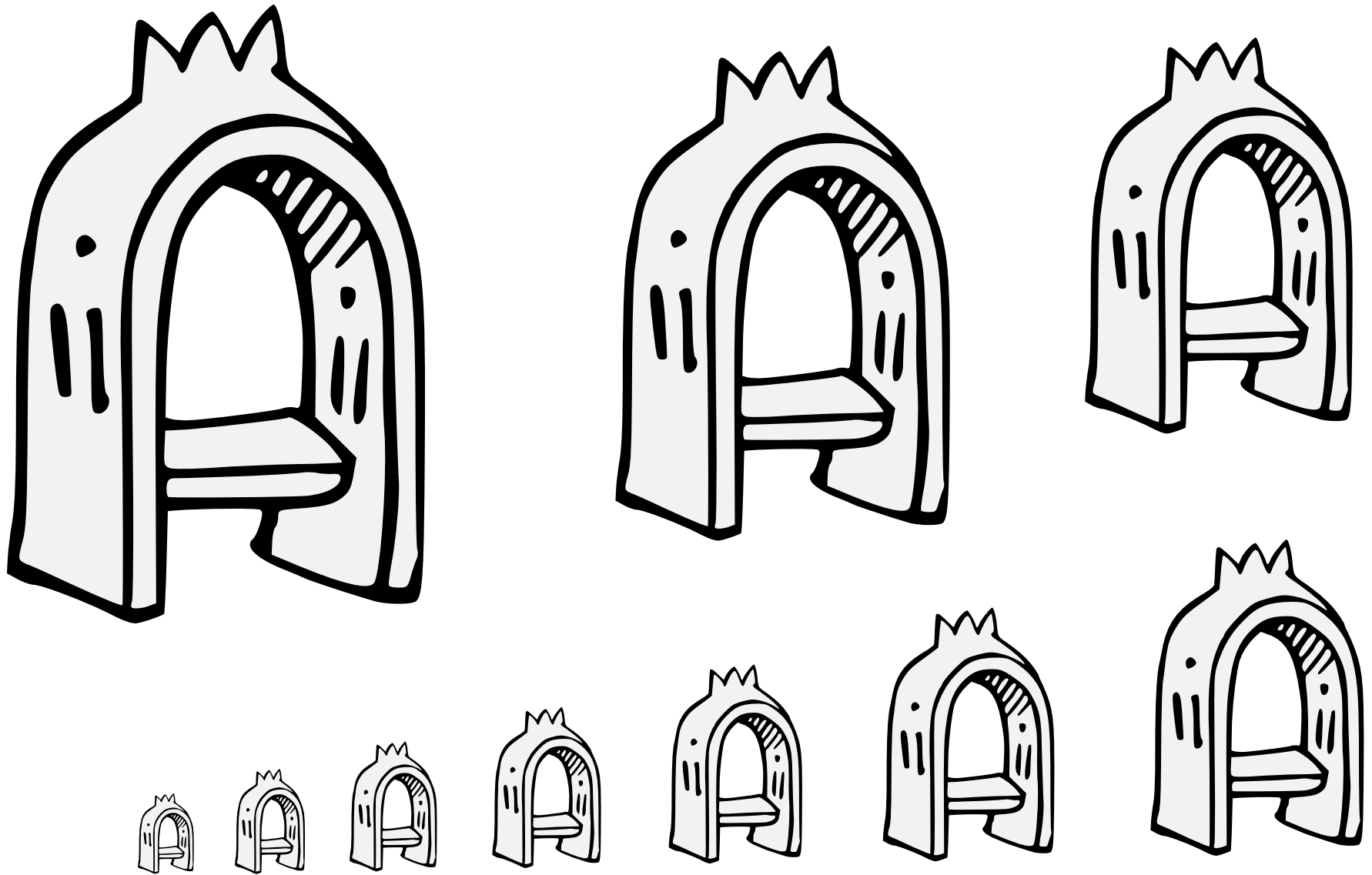

A horseback rider's foot rest.

Default orientation: upright. No proper coloration.

Source: Banners, Standards, and Badges. Artist: Thomas Willement.

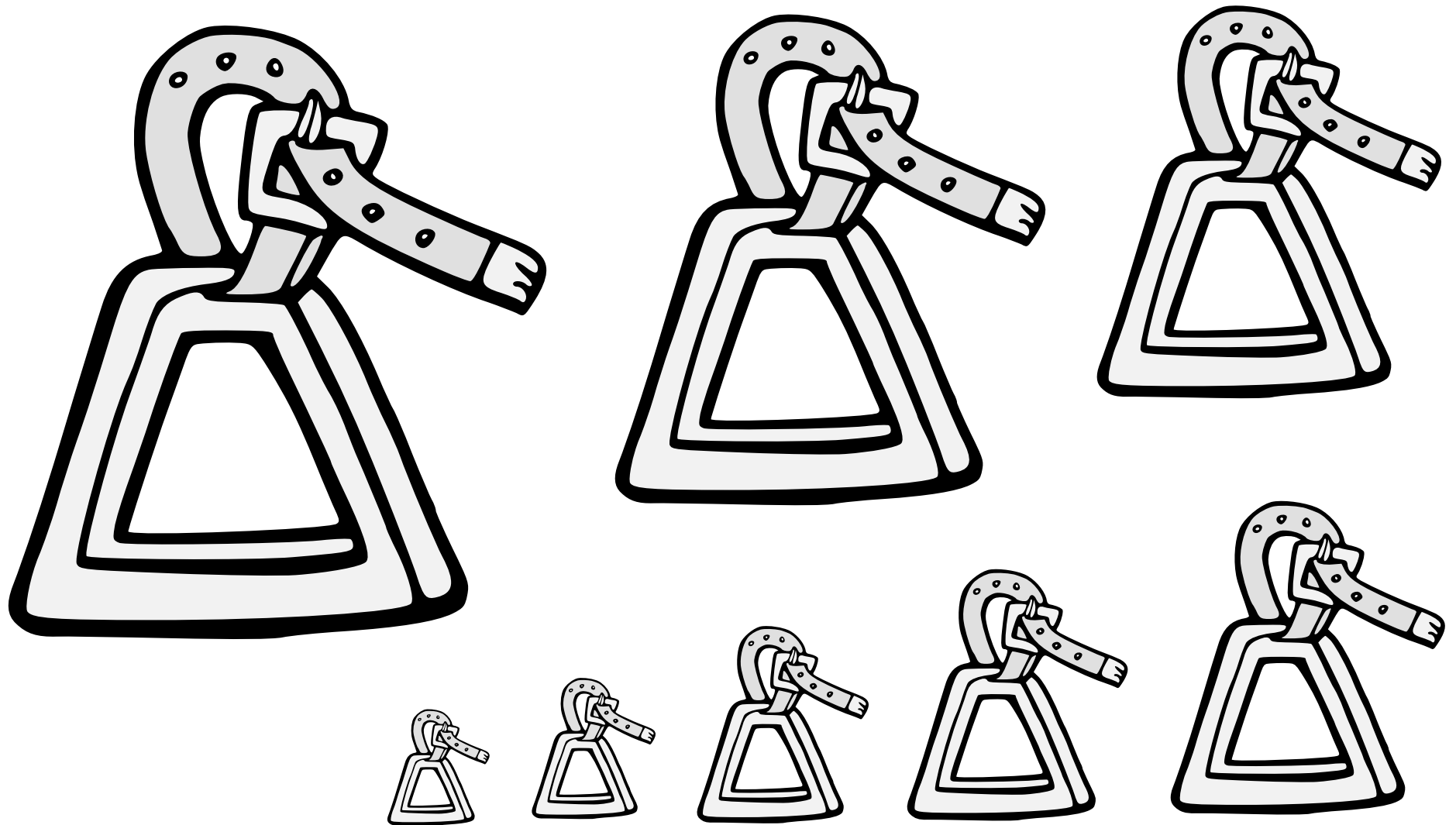

A horseback rider's foot rest.

Default orientation: upright. No proper coloration.

Source: Two Tudor Books of Arms. Artist: Robert Cooke.
(From page 150, arms of John Seycmor.)

Stirrup (2) 19.156

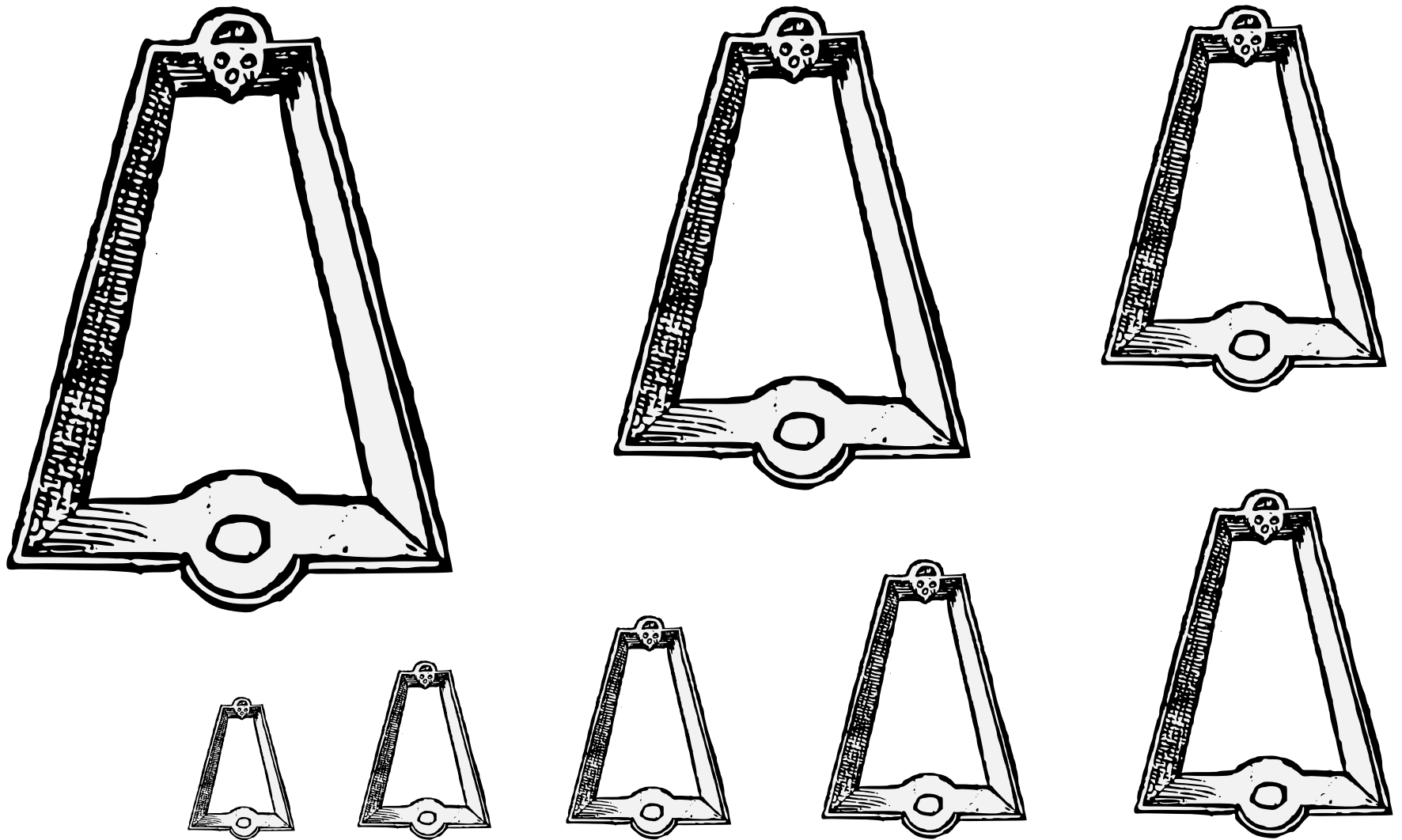

A horseback rider's foot rest.

Default orientation: upright. No proper coloration.

Source: Arma Regni Poloniae. Artist unknown. (Herb of Strzemie, p. 48.)

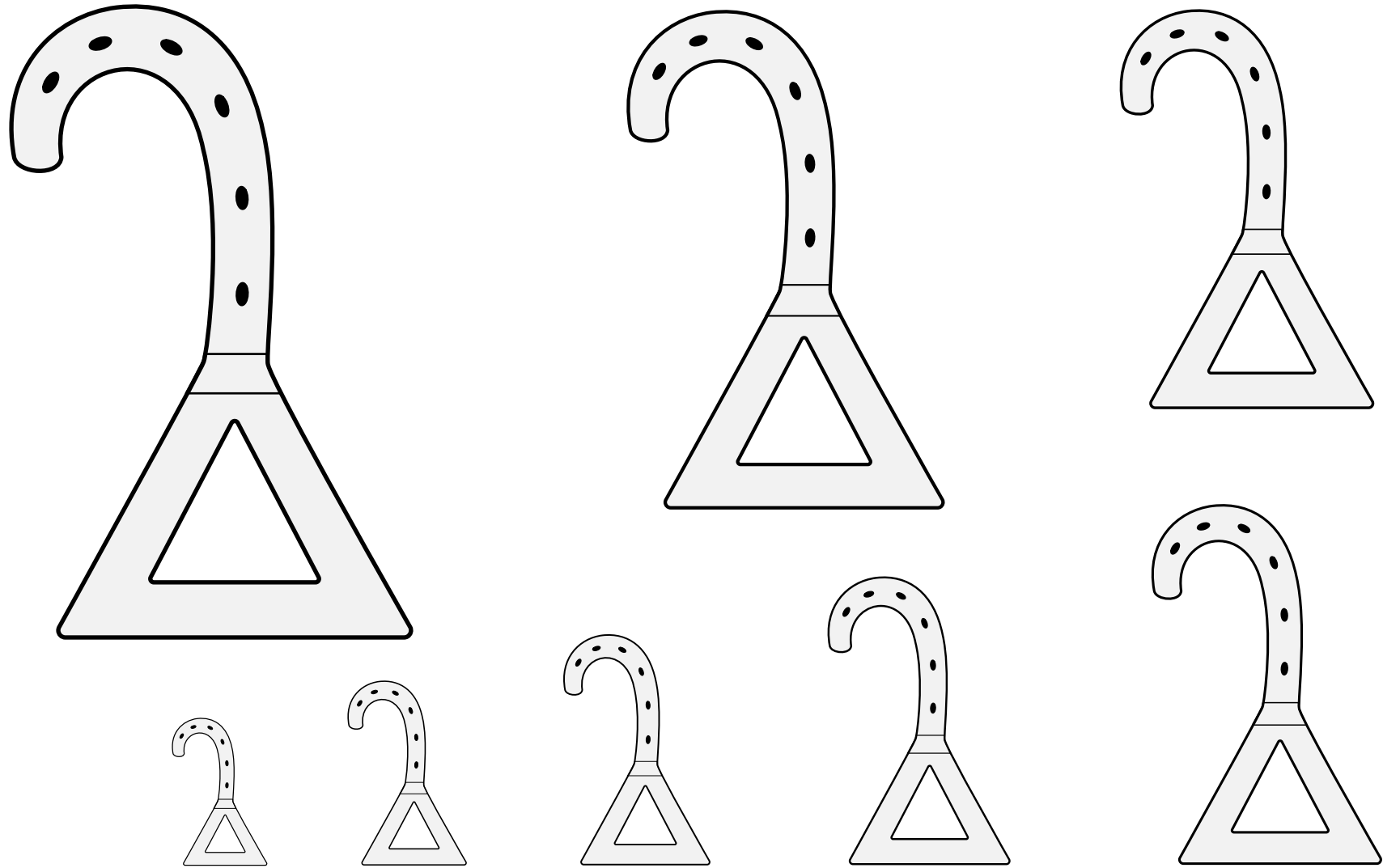

A horseback rider's foot rest.

Default orientation: upright. No proper coloration.

Source: Thomas Jenyn's Book. Artist unknown. (Folio 88r.)

Stirrup (4) 19.158

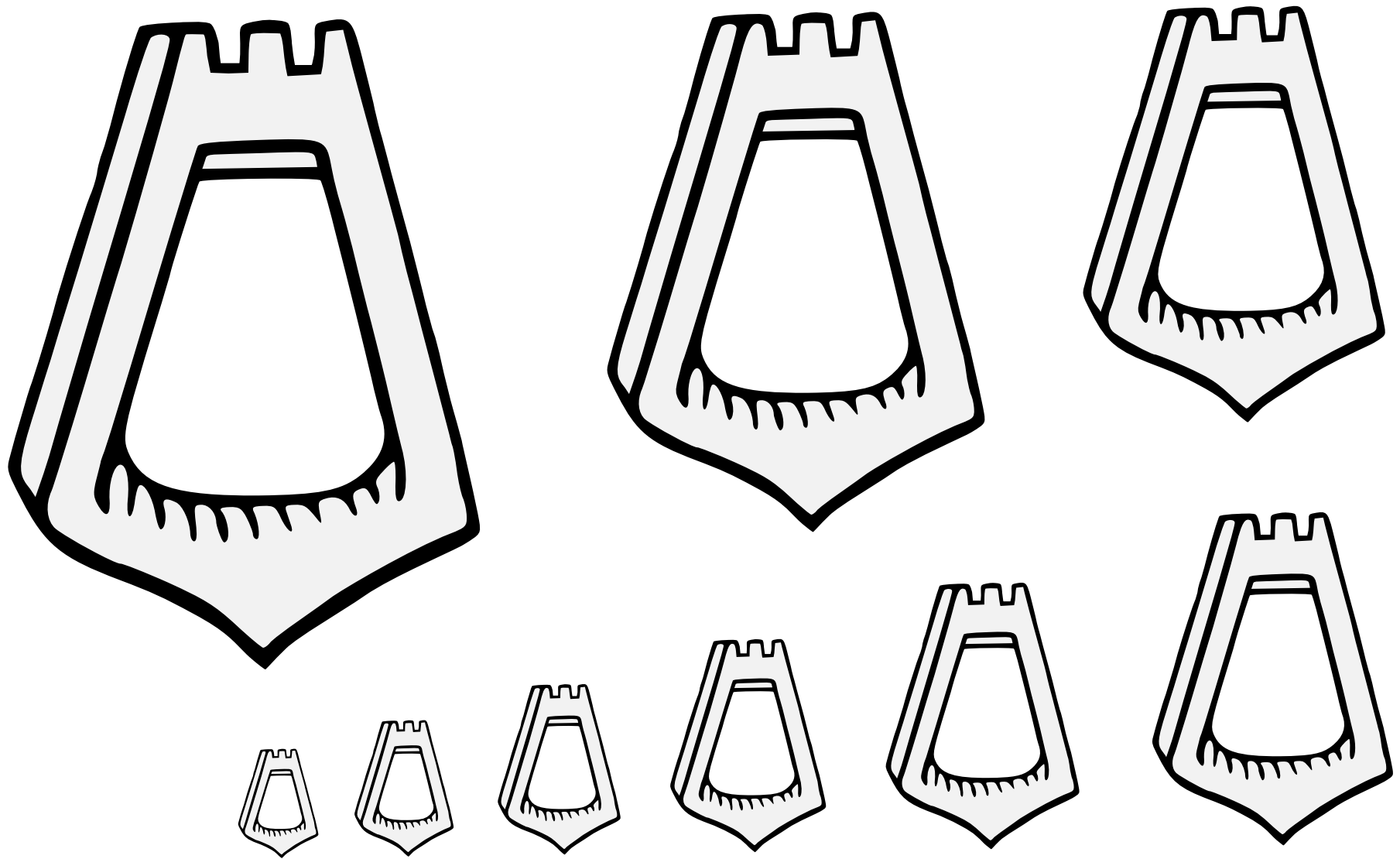

A horseback rider's foot rest.

Default orientation: upright. No proper coloration.

Source: Two Tudor Books of Arms.

Artist: Robert Cooke. (From page 34.)

Stirrup (5) 19.159

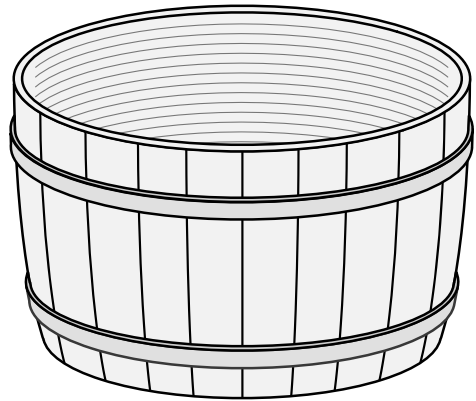
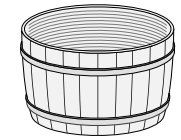
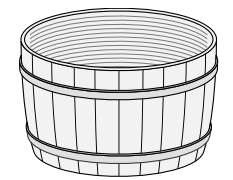
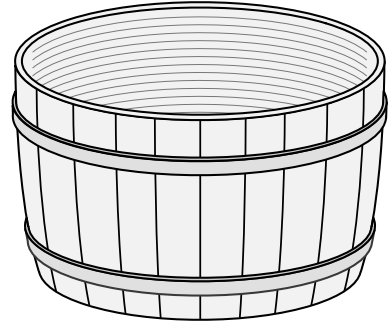
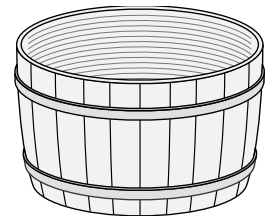
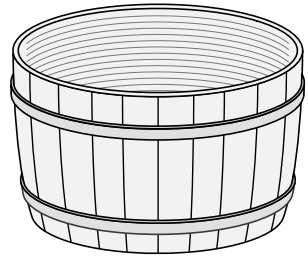
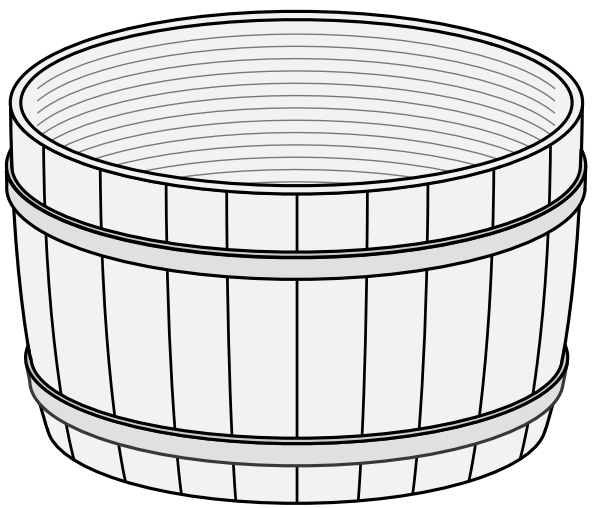
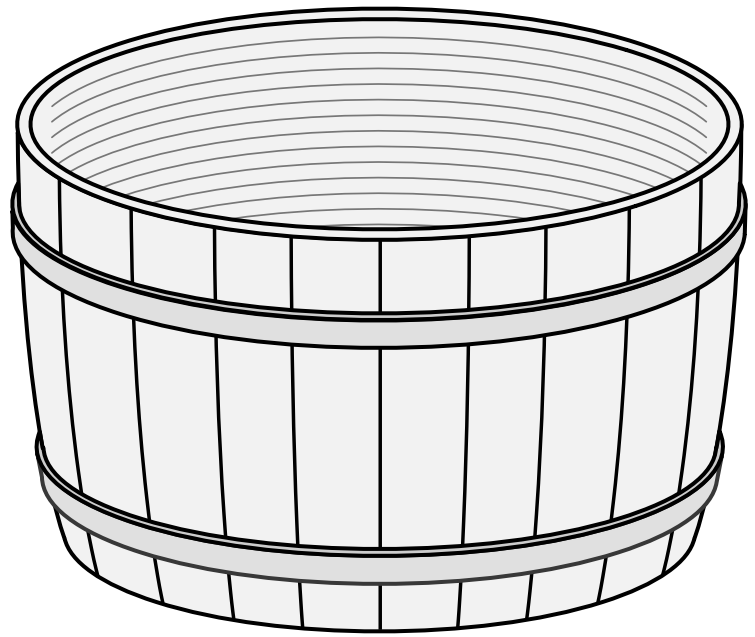

An enormous bucket.

Default orientation: opening to chief. Proper coloration: brown wood.

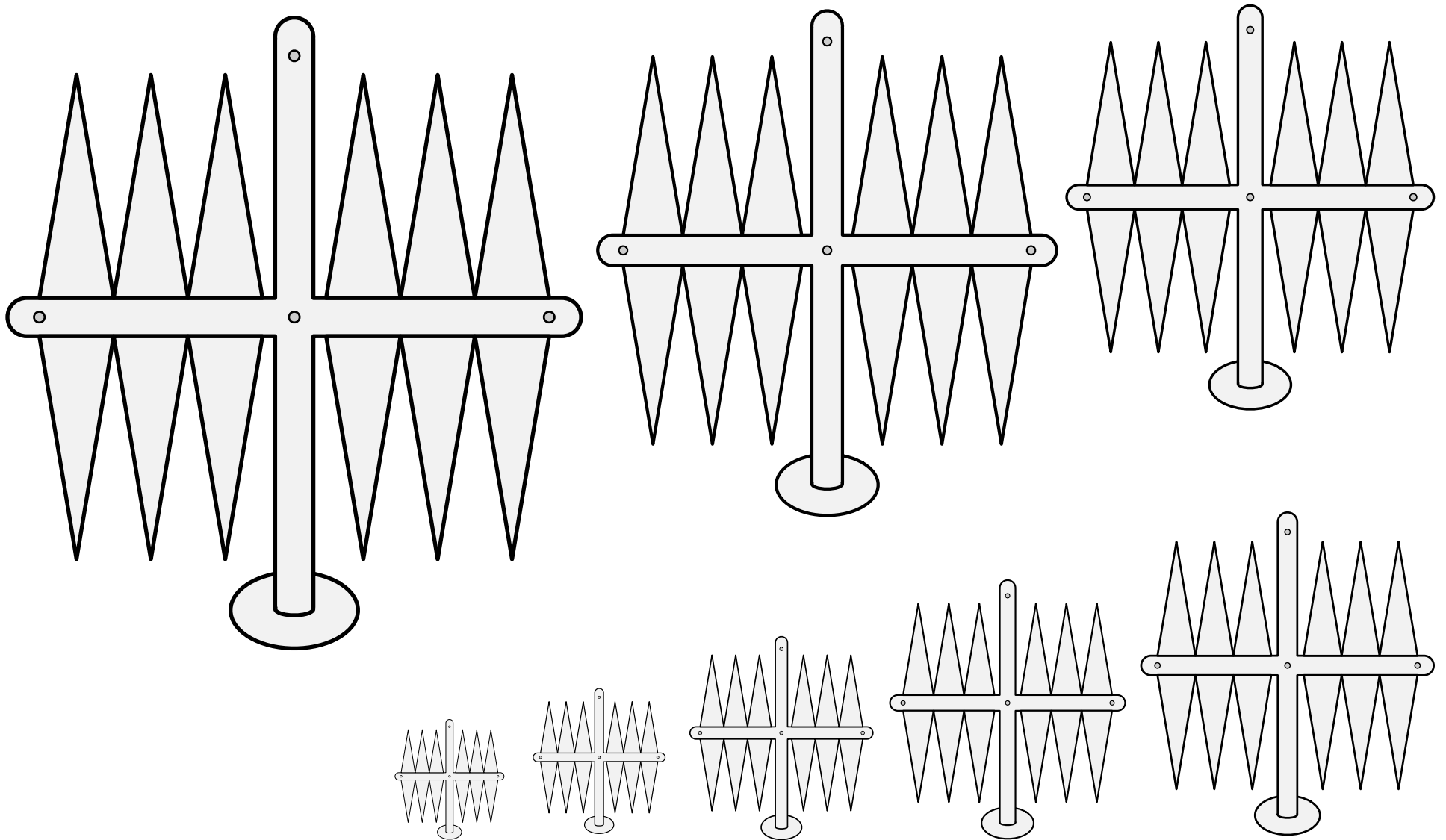

A rack used to hold fodder for farm animals.

Default orientation: upright. No proper coloration.

Source: Siebmacher's Wappenbuch of 1605. Artist: Johann Siebmacher.
(Arms of Die Lammingen, plate 89.)

Turning Cratch (1) 19.161

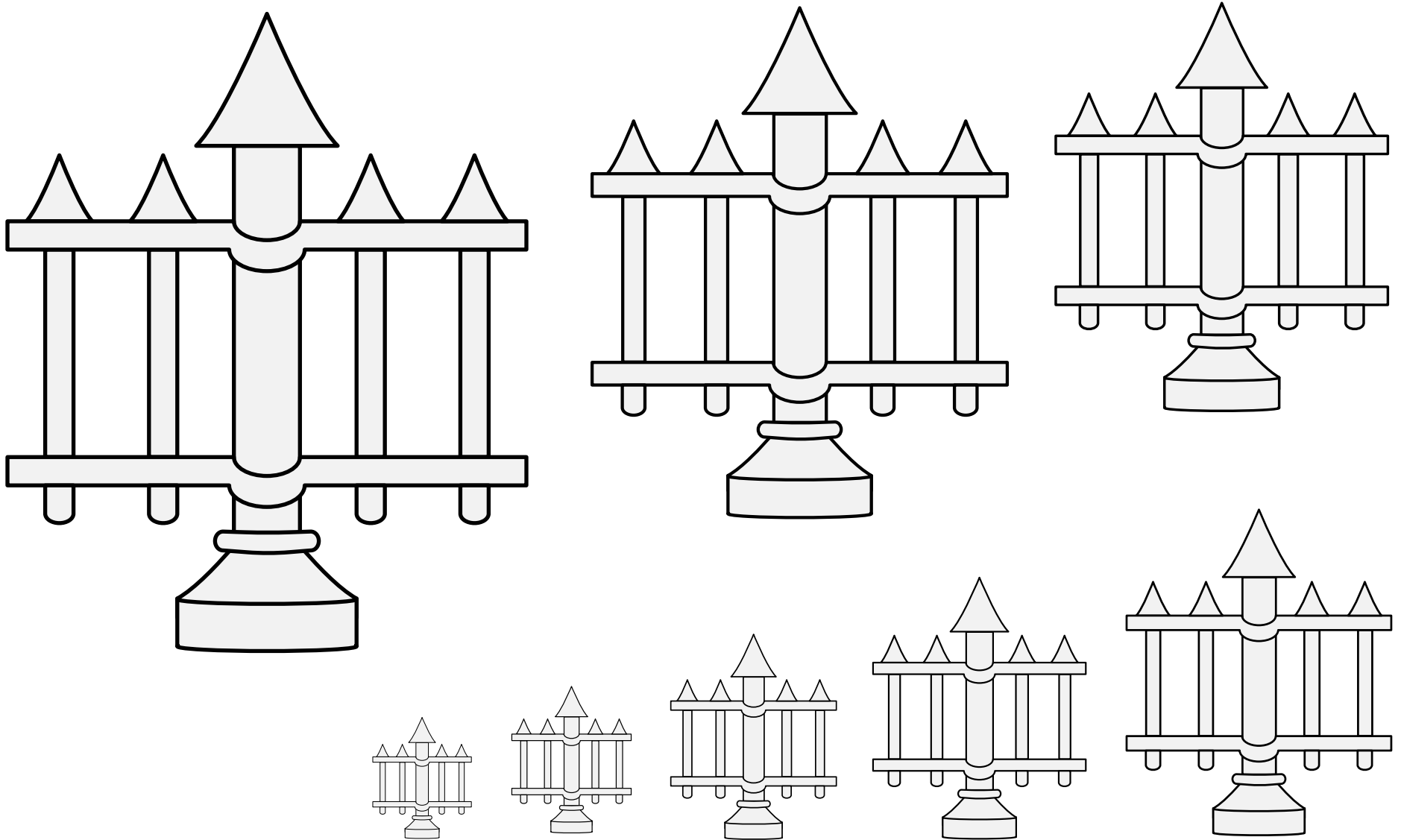

A rack used to hold fodder for farm animals.

Default orientation: upright. No proper coloration.

Source: Heiligen Römischen Reiches. Artist unknown.
(Arms of von Hertenberg, page 912.)

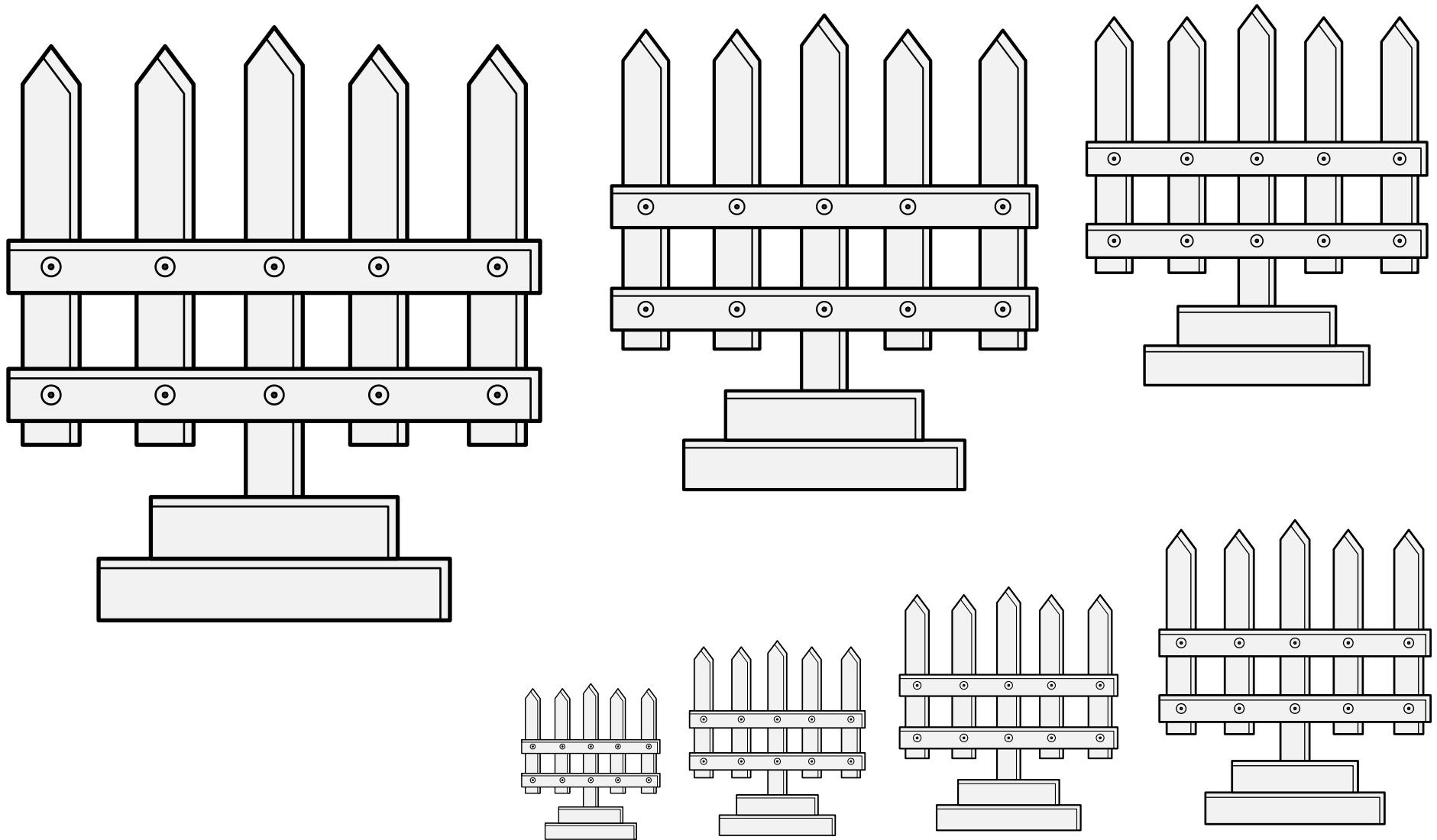

A rack used to hold fodder for farm animals.

Default orientation: upright. No proper coloration.

Source: Des Kaiserlichen Kammergerichts zu Speier Kammerrichter. Artist unknown. (Folio 20v.)

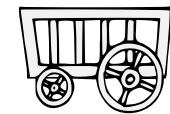
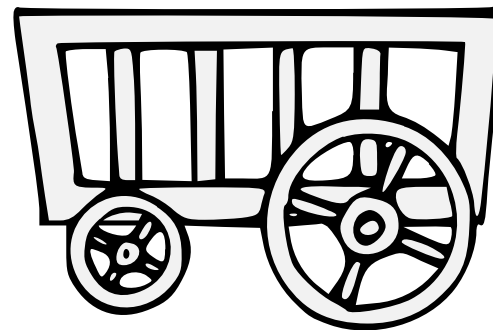
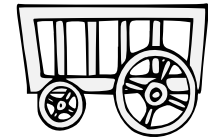
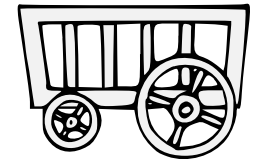
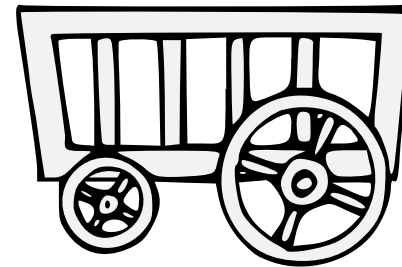
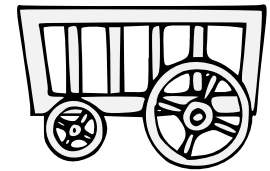
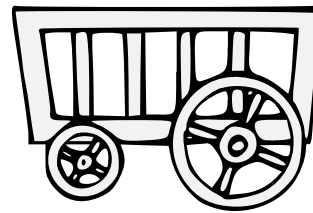
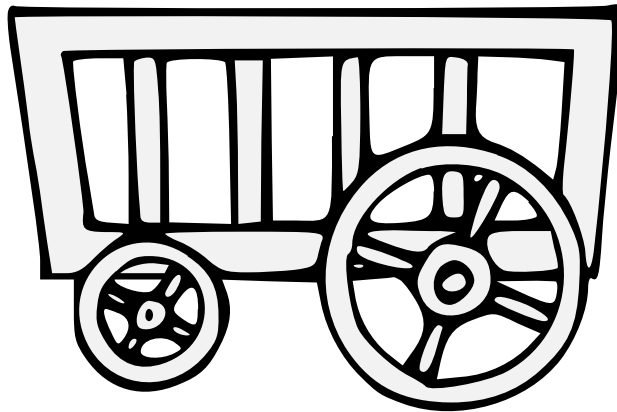
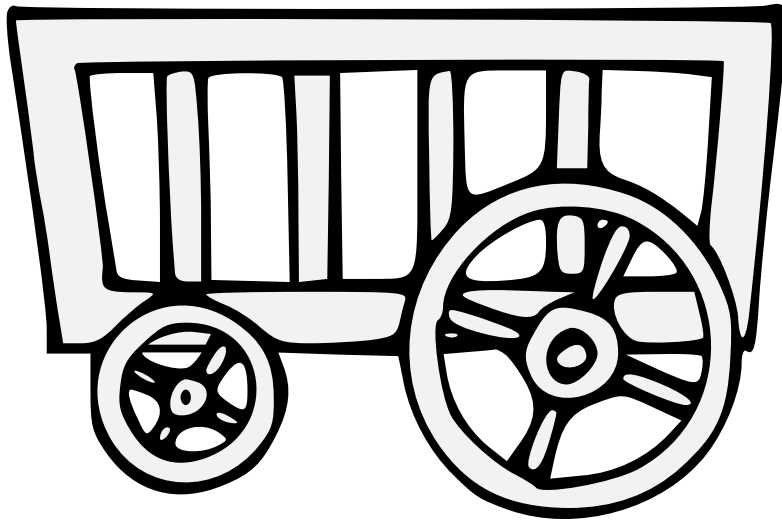

A wheeled vehicle suitable for carrying a farmer's harvest. May be blazoned a "cart."
Default orientation: wheels to base, driving to dexter. Proper coloration: brown wood.
Source: Pennsic Traceable Art. Artist unknown.

Wagon (1) 19.164

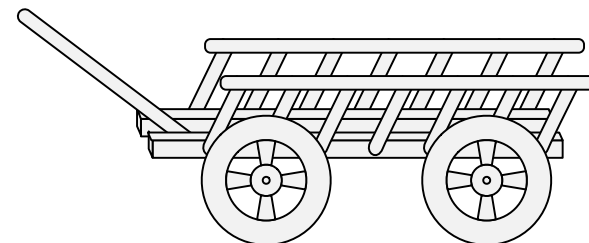
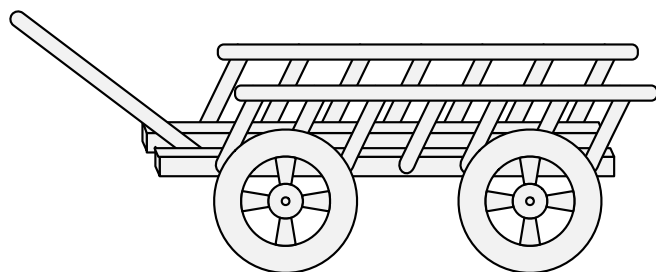
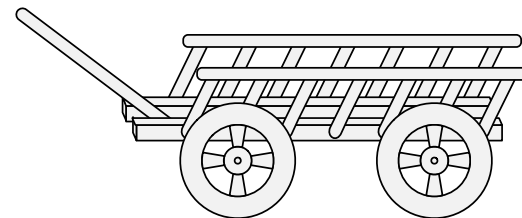
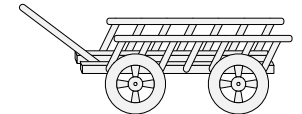
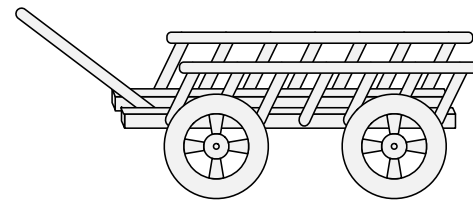
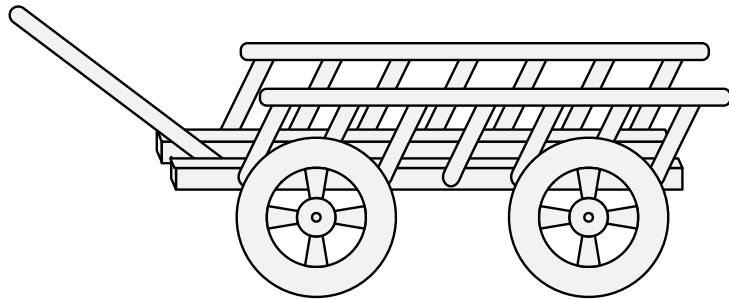
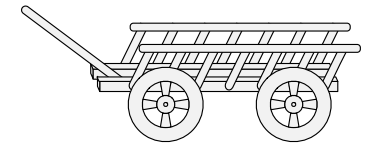
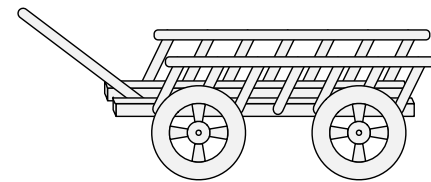
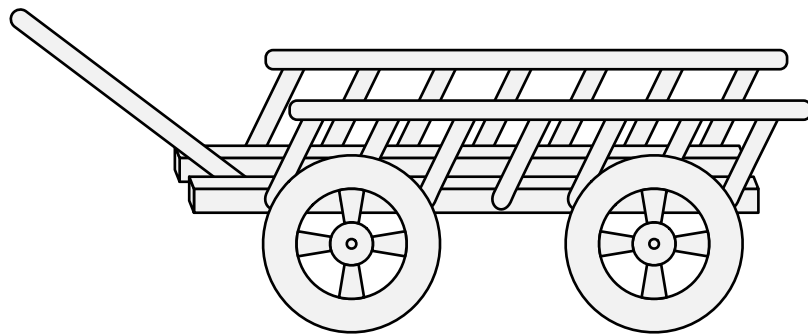

A wheeled vehicle suitable for carrying a farmer's harvest. May be blazoned a "cart."

Default orientation: wheels to base, driving to dexter. Proper coloration: brown wood.

Source: Stemmario Trivulziano. Artist: Gian Antonio da Tradate.
(Arms of di Branbilla, folio 69r.) Adapted by Mathghamhain Ua Ruadháin.

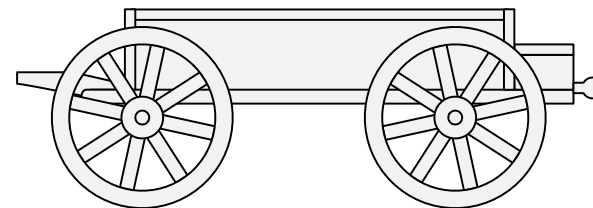
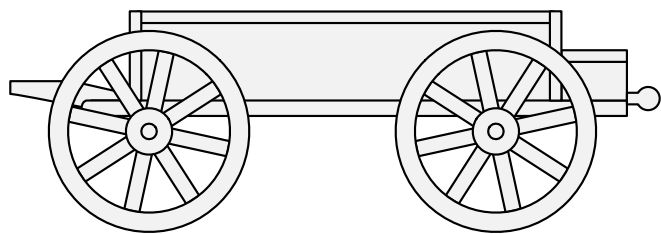
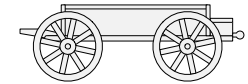
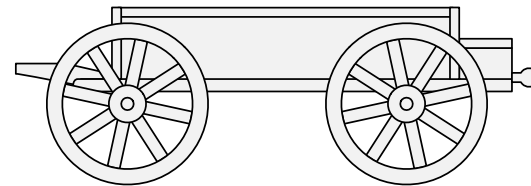
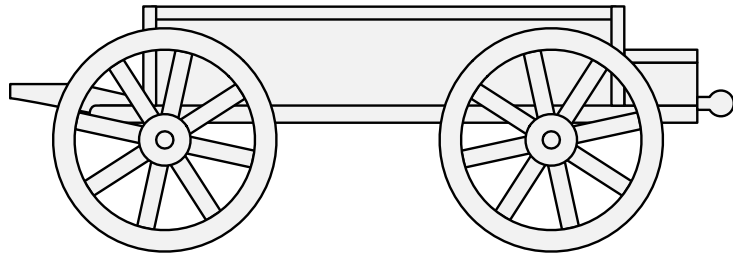
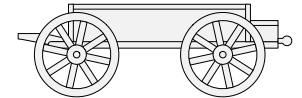
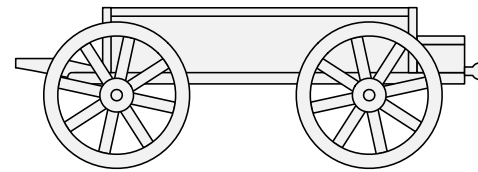
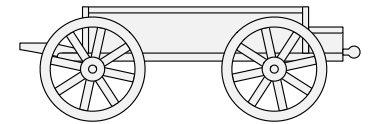
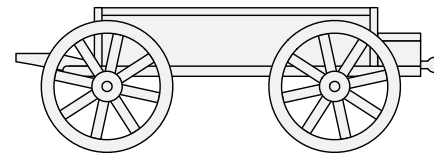
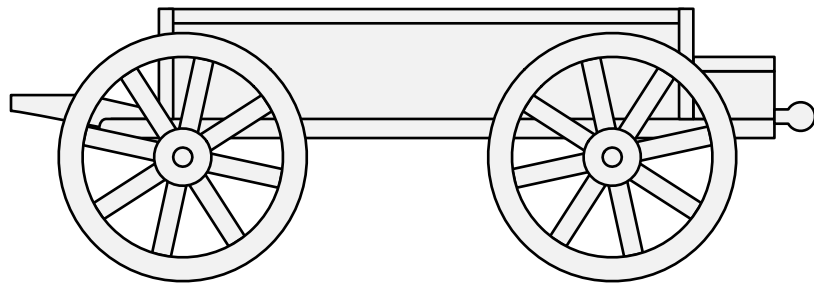

A wheeled vehicle suitable for carrying a farmer's harvest. May be blazoned a "cart."

Default orientation: wheels to base, driving to dexter. Proper coloration: brown wood.

Source: Douce Psalter (Oxford MS Douce 6, folio 200v). Artist unknown.

Adapted by Mathghamhain Ua Ruadháin.

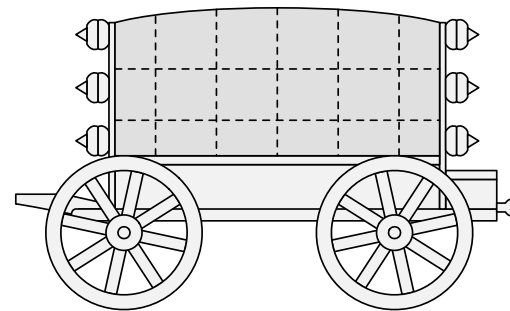
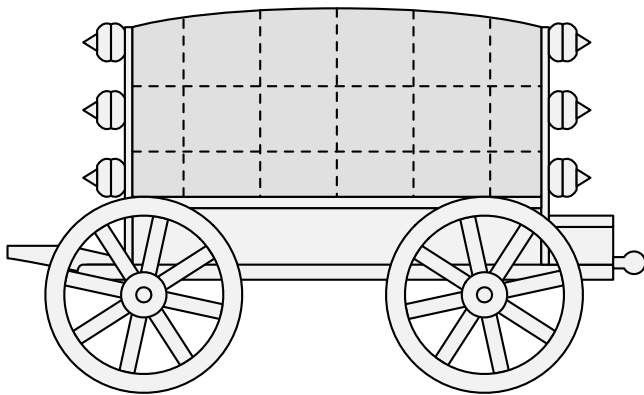
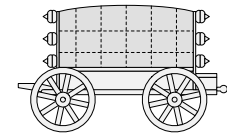
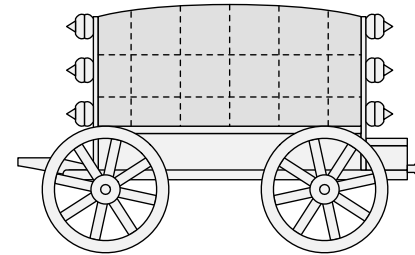
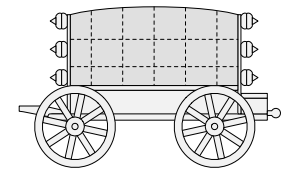
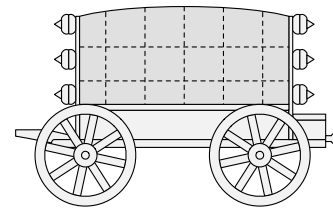
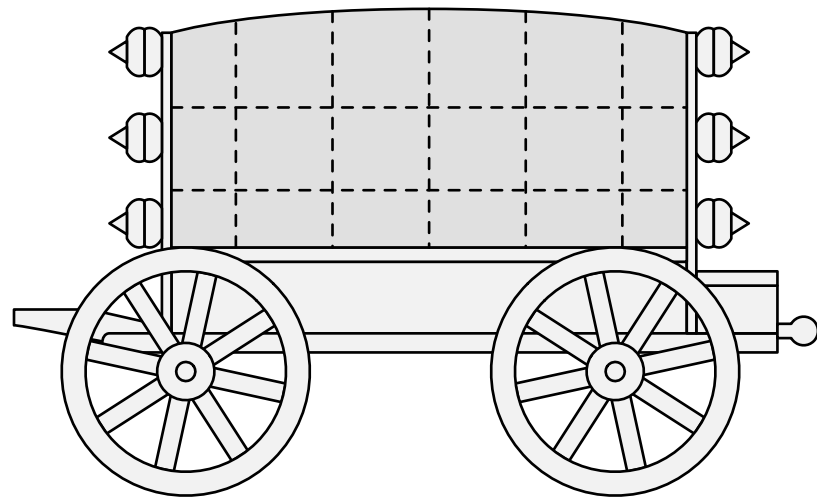

A passenger cart, with its body surmounted by a cloth covering supported by wooden hoops.

Default orientation: wheels to base, driving to dexter. Proper coloration: brown wood.

Source: Douce Psalter (Oxford MS Douce 6, folio 200v). Artist unknown.

Wagon, Covered 19.167

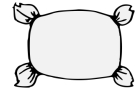
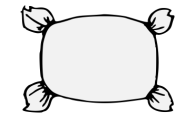
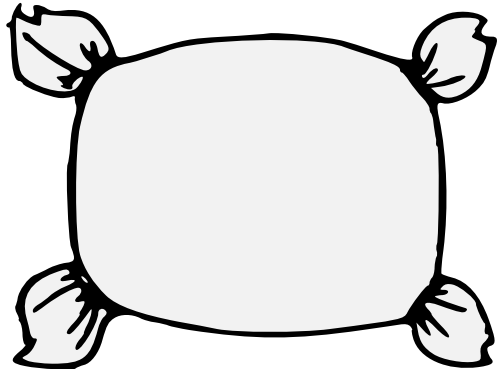
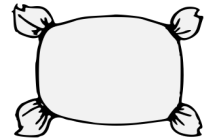
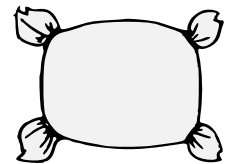
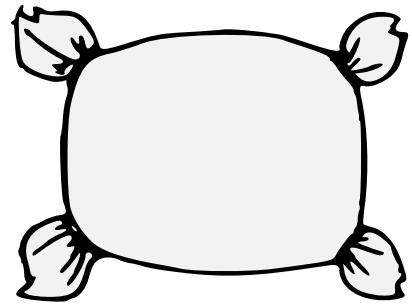
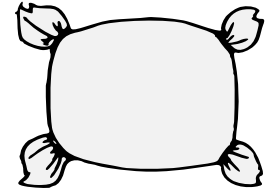
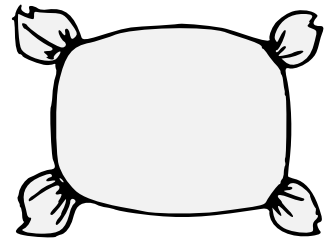
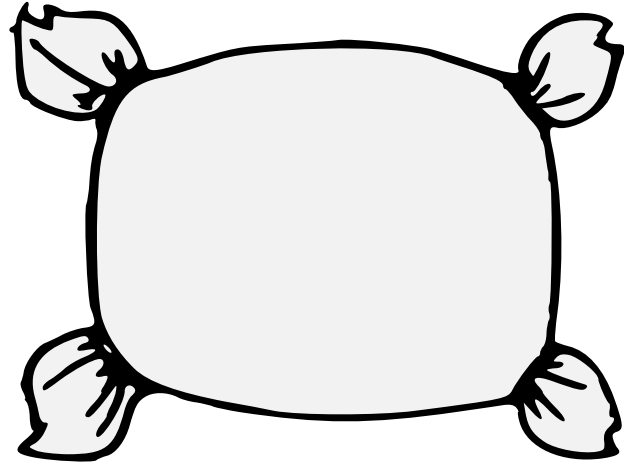
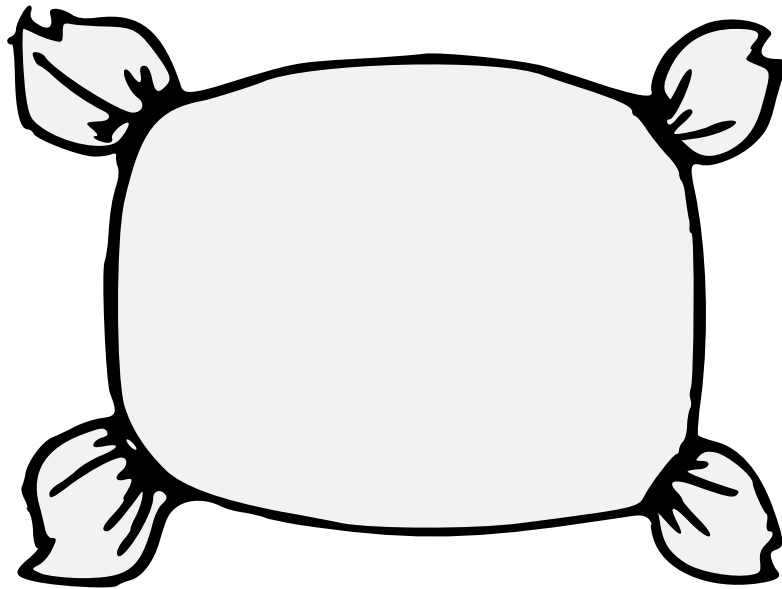

A sack stuffed with wool.

Default orientation: fesswise. No proper coloration.

Source: Pennsic Traceable Art. Artist: Roana d'Evreux.

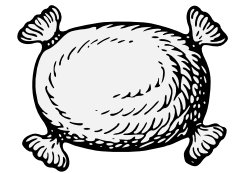
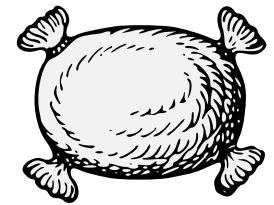
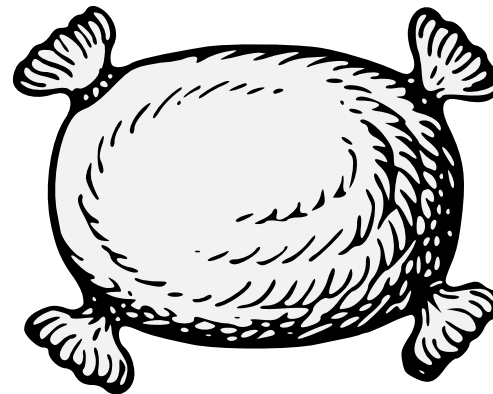
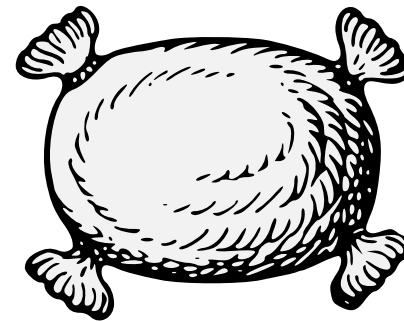
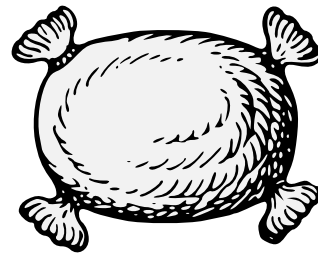
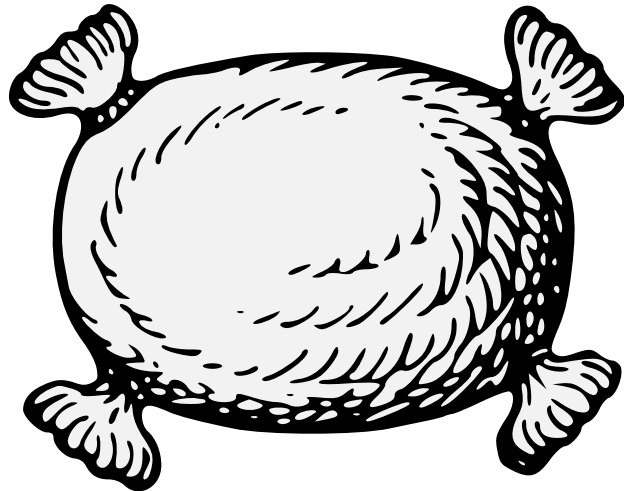
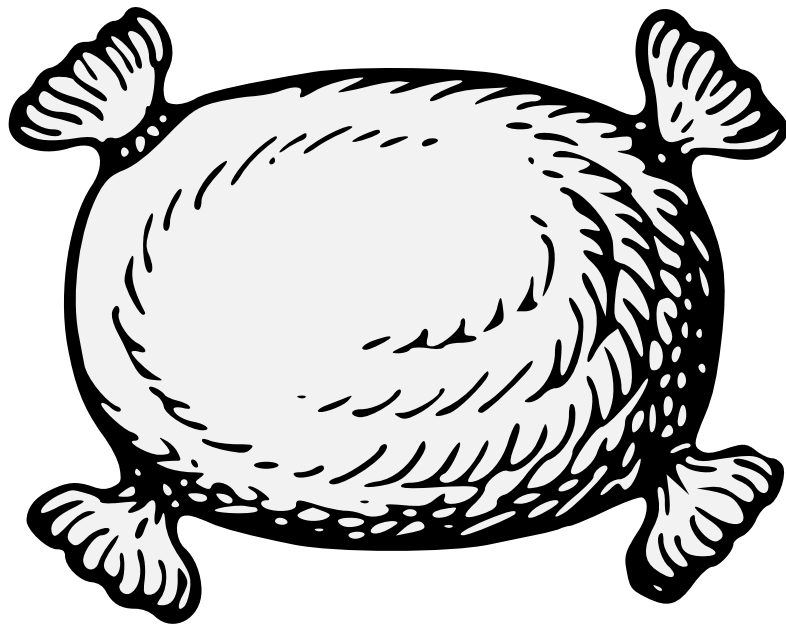

A sack stuffed with wool.

Default orientation: fesswise. No proper coloration.

Source: A Complete Guide to Heraldry. Artist: Graham Johnston.

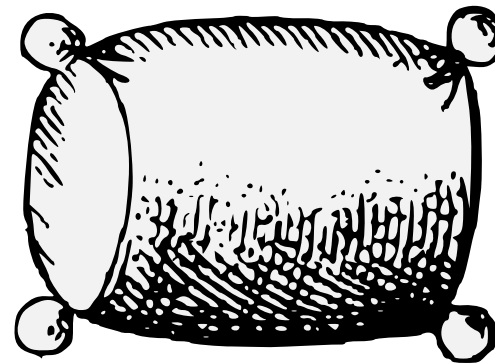
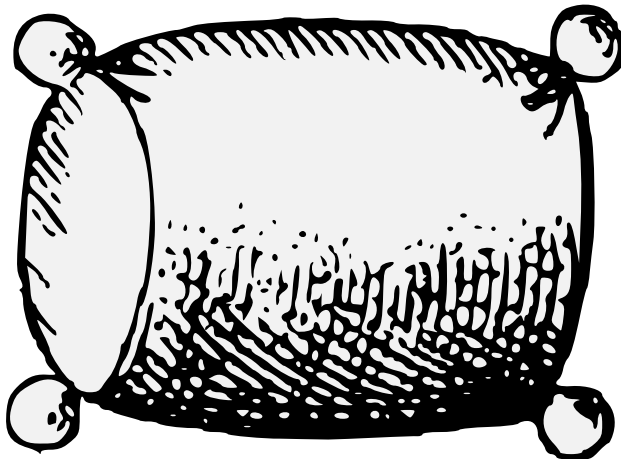
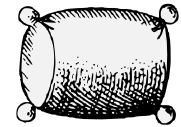
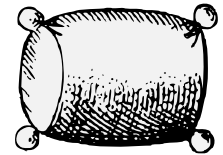
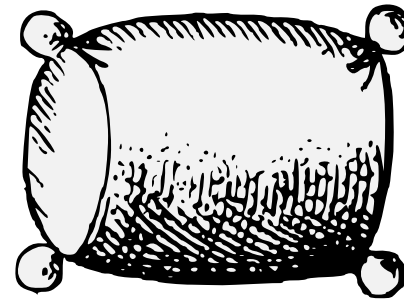
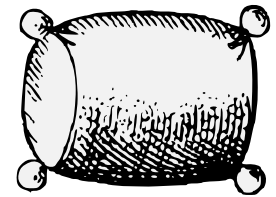
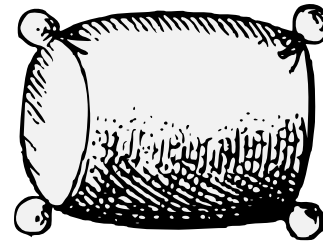
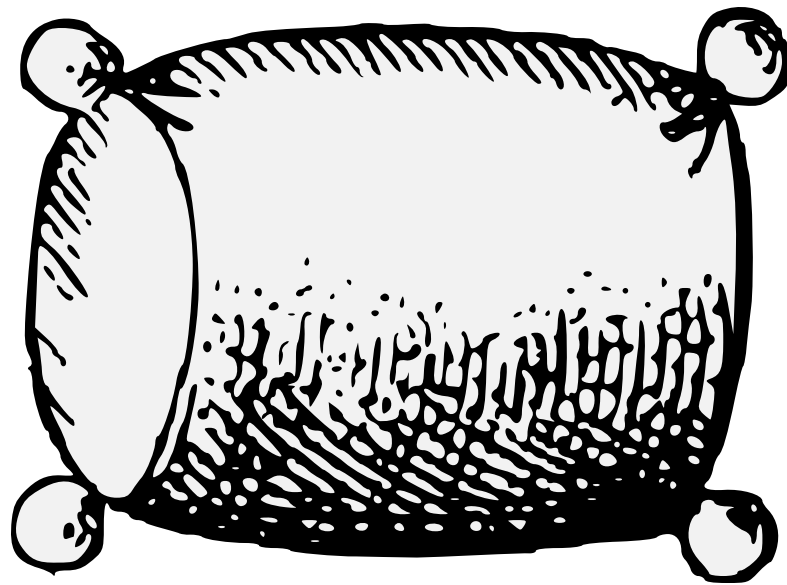

A sack stuffed with wool.

Default orientation: fesswise. No proper coloration.

Source: The Armes of All the Cheife Corporatons.
Adapted by Mathghamhain Ua Ruadháin.
(From the arms of the Woolpackers' Company.)

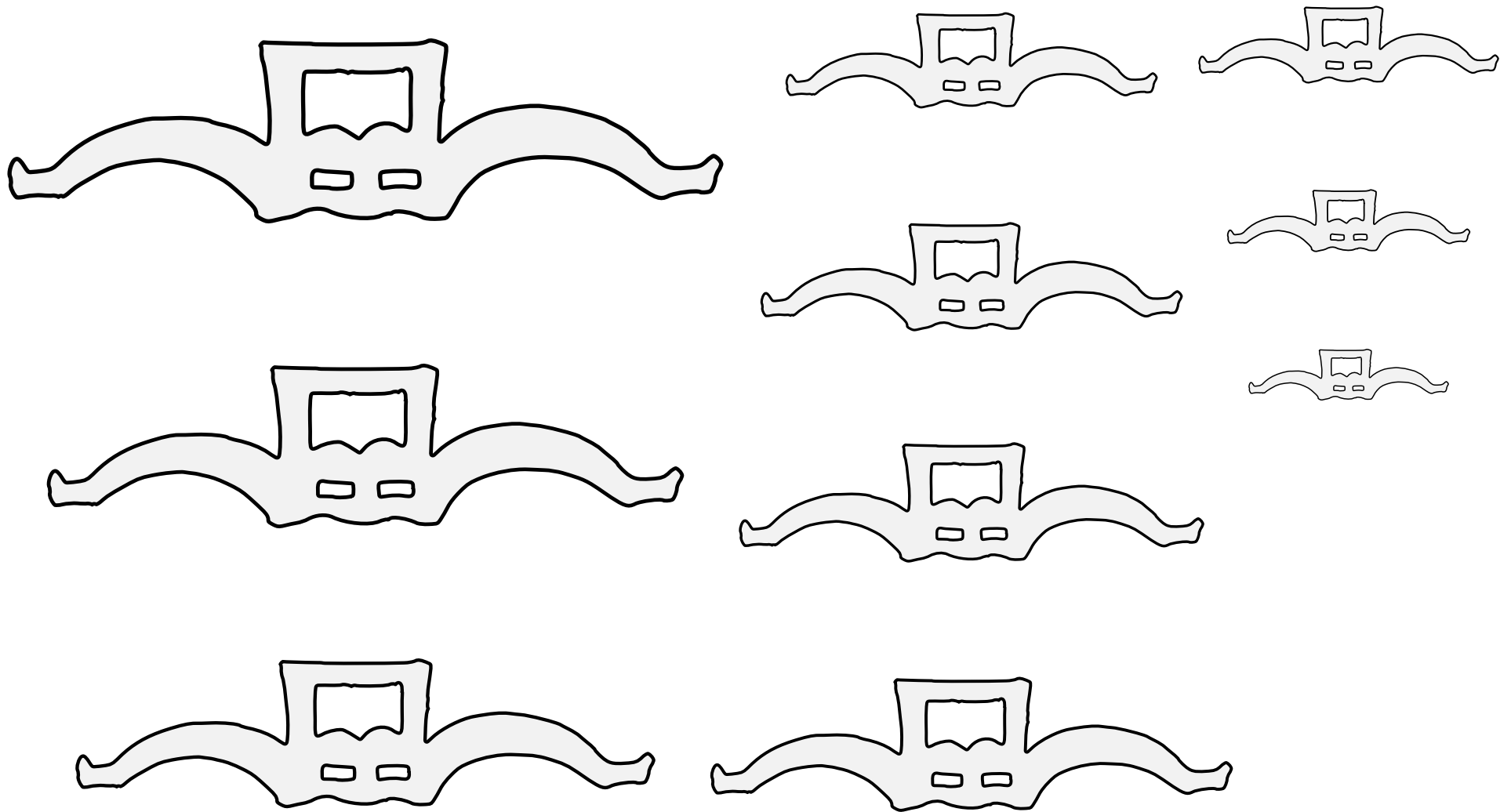

A mechanism for harnessing animals to pull a heavy load

Default orientation: fesswise. No proper coloration.

Source: Scheibler Armorial. Artist unknown. (From the arms of von Aichen.)

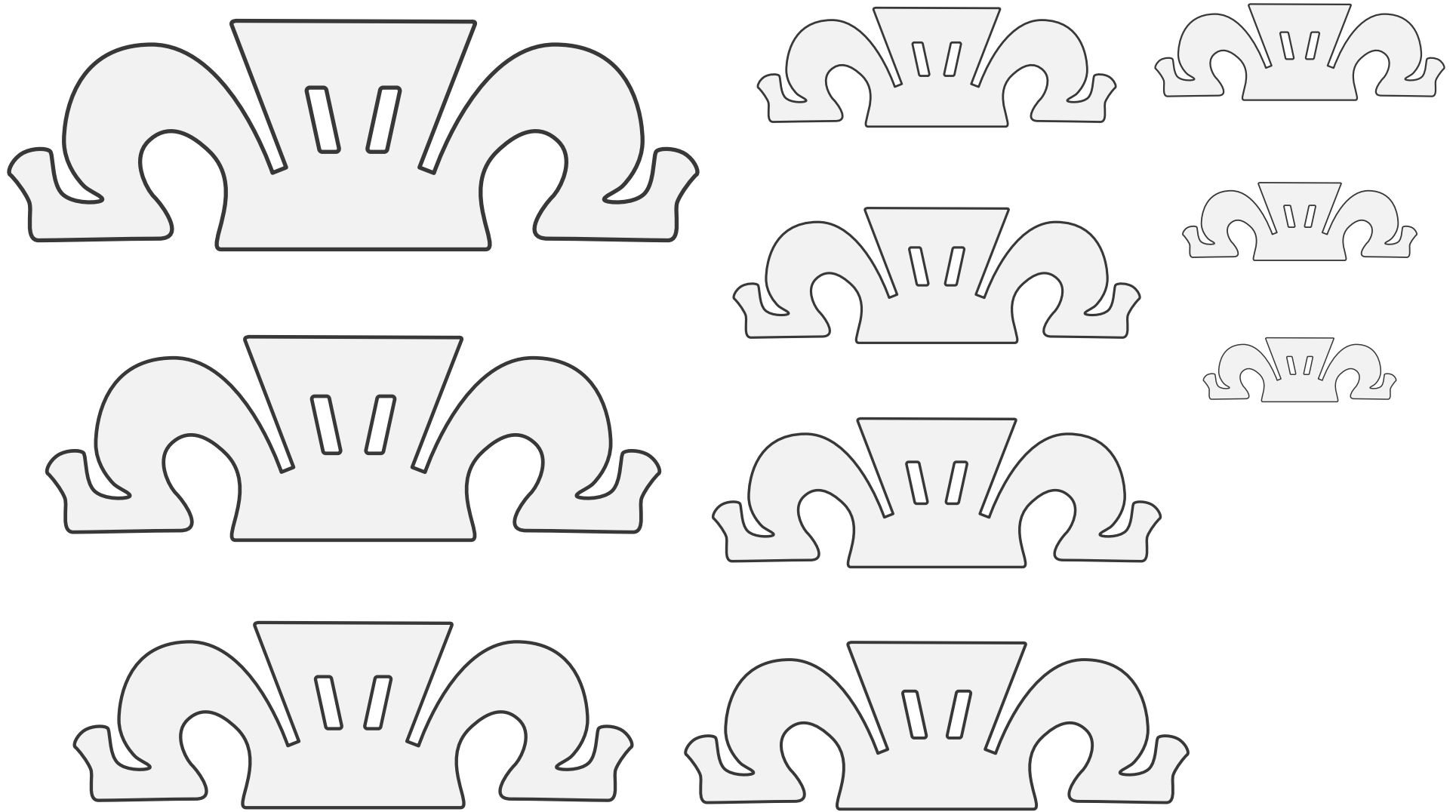

A mechanism for harnessing animals to pull a heavy load

Default orientation: fesswise. No proper coloration.

Source: Zurich Roll. Artist unknown. Adapted by Mathghamhain Ua Ruadháin.

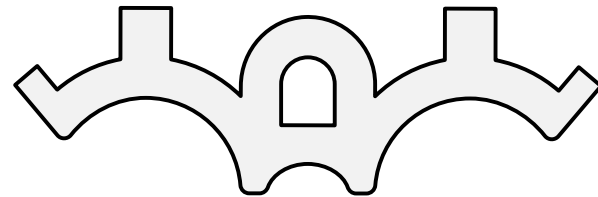
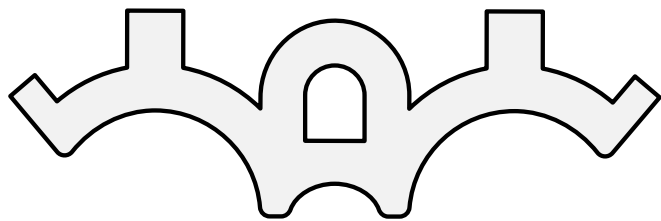
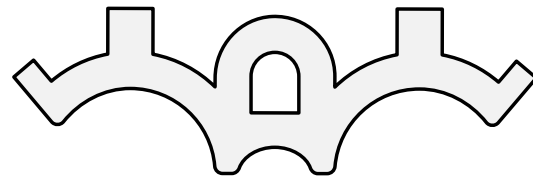
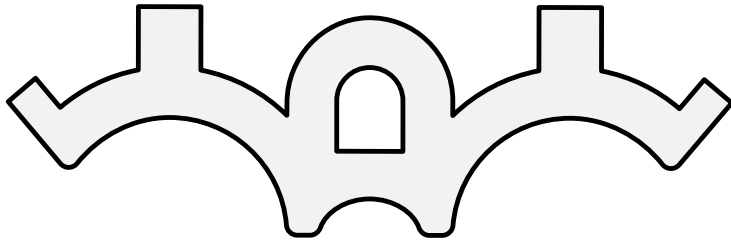
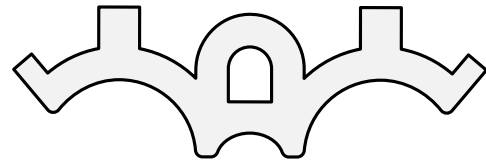
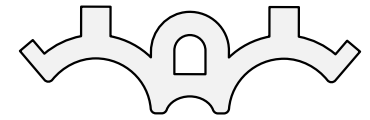
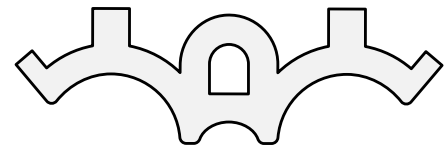
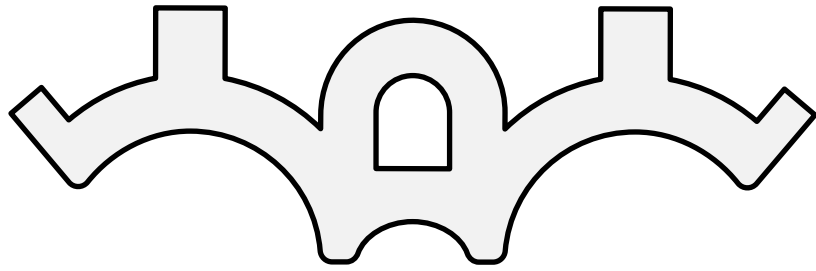

A mechanism for harnessing animals to pull a heavy load

Default orientation: fesswise. No proper coloration.

Source: WappenWiki. Artist: Joakim Spuller.