

❧ Book of Traceable Heraldic Art ❧

Volume 21:

Military

Including Weapons & Armor

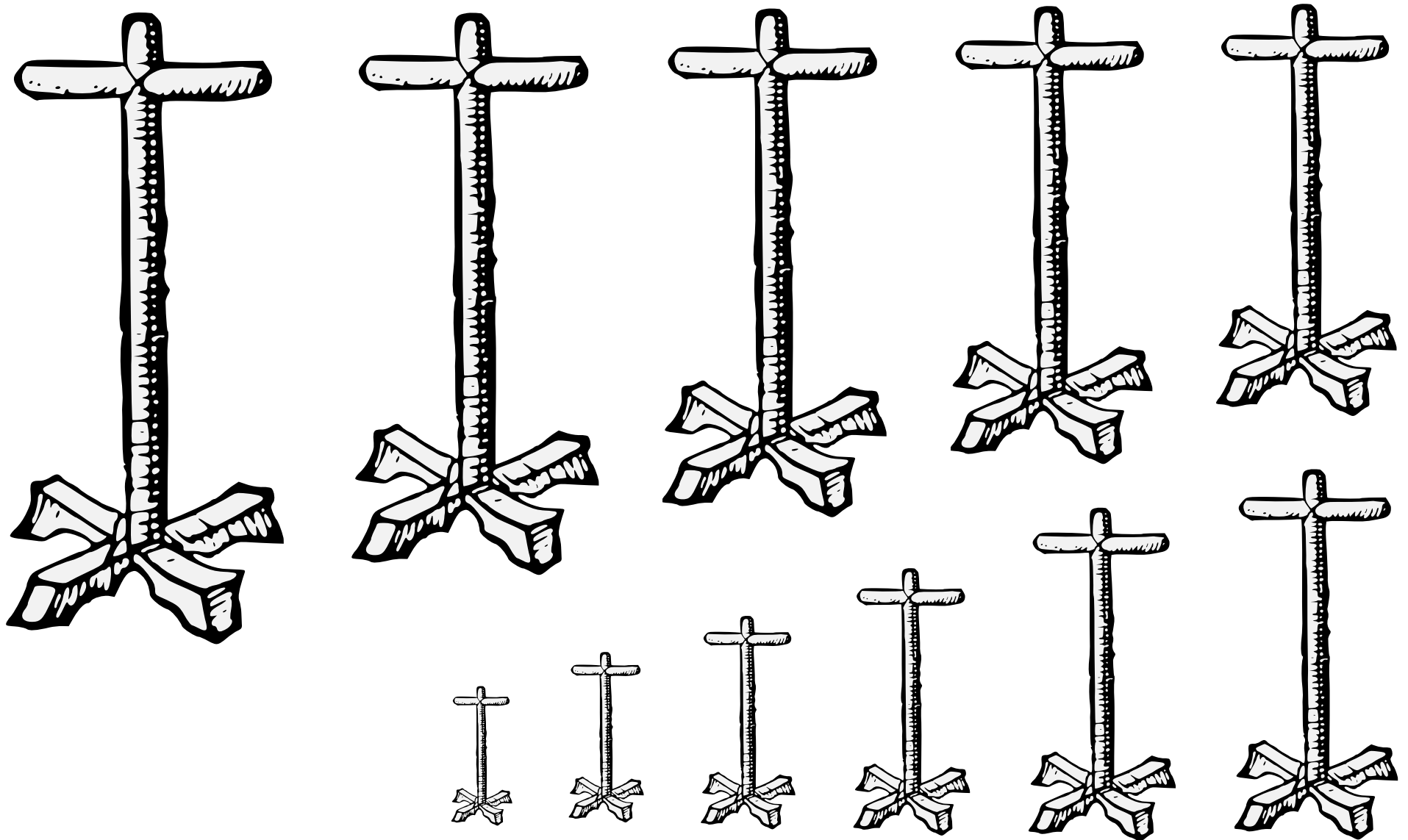

A rack from which a suit of armor may be hung for storage.  
Default orientation: upright. Proper coloration: brown wood.  
Source: Le Blason Des Armoiries. Artist: Jérôme de Bara.

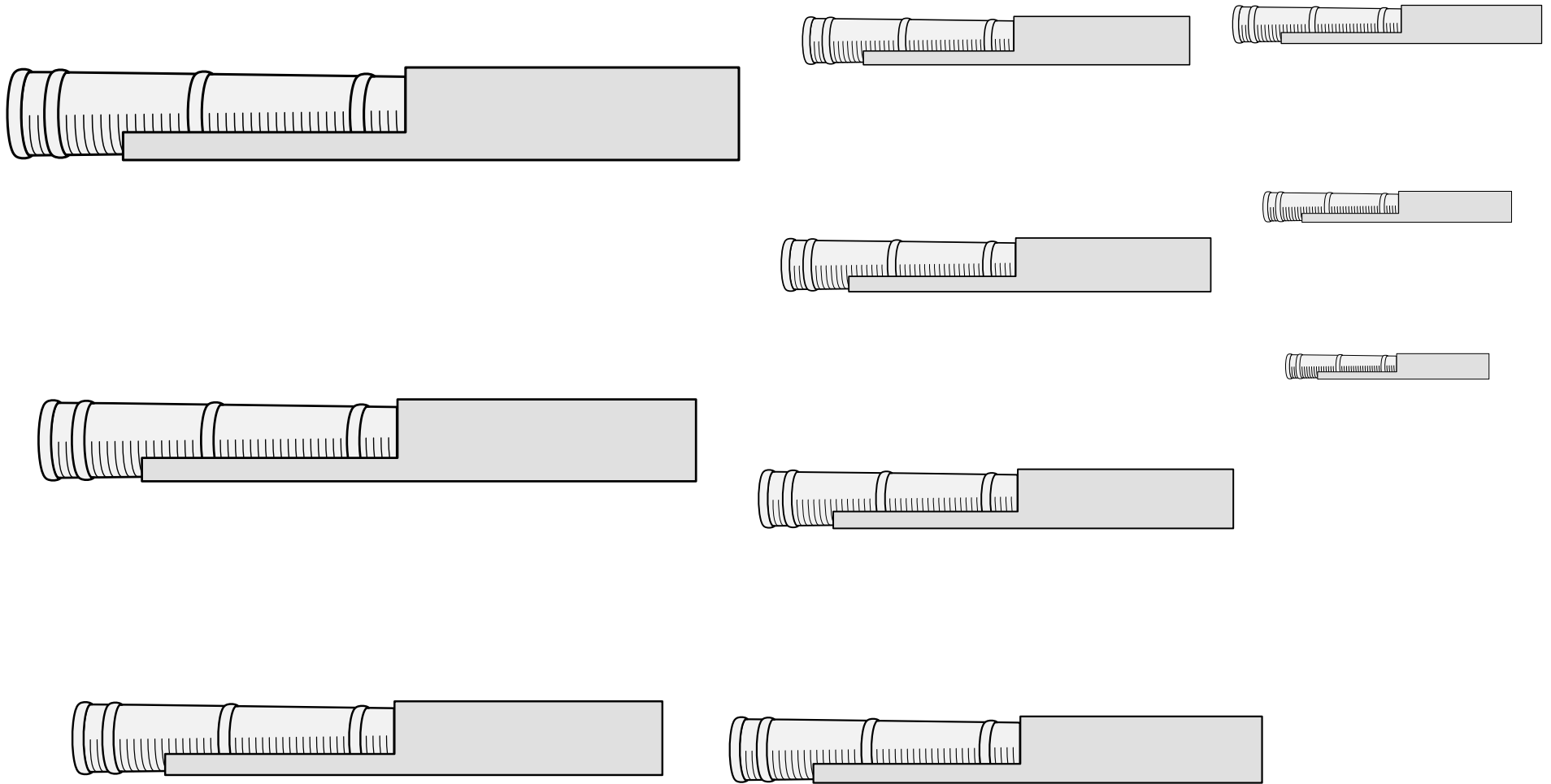

An early type of gun.

Default orientation: fesswise, firing to dexter. No proper coloration.

Source: Le second volume de la premiere partye du blason d'armoiries. Artist unknown. (Folio 129r.)

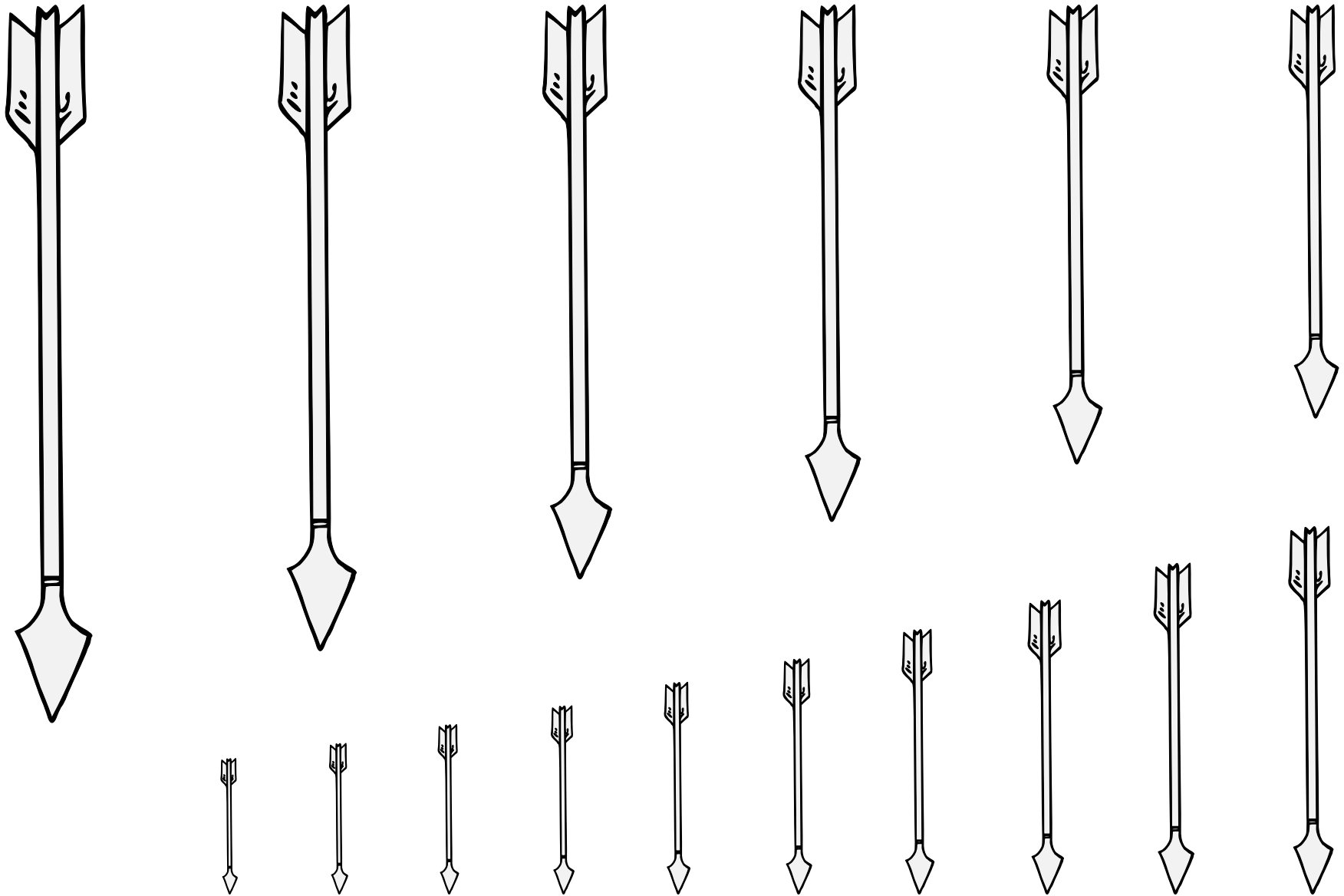

A projectile for use with a bow.

Default orientation: point to base.

Source: Pennsic Traceable Art. Artist: Roana d'Evreux.



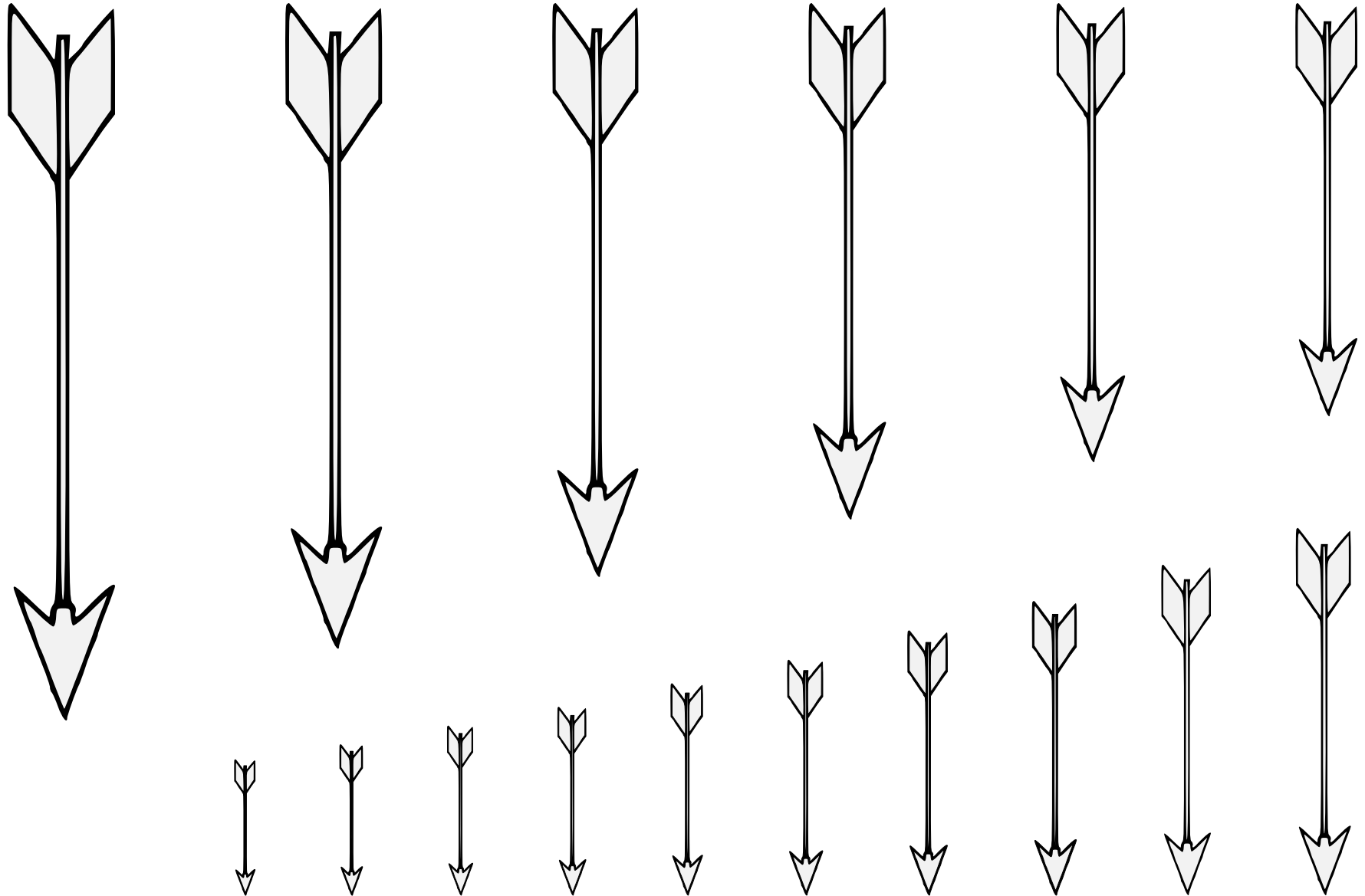

A projectile for use with a bow.

Default orientation: point to base.

Source: Pennsic Traceable Art. Artist: Roana d'Evreux.

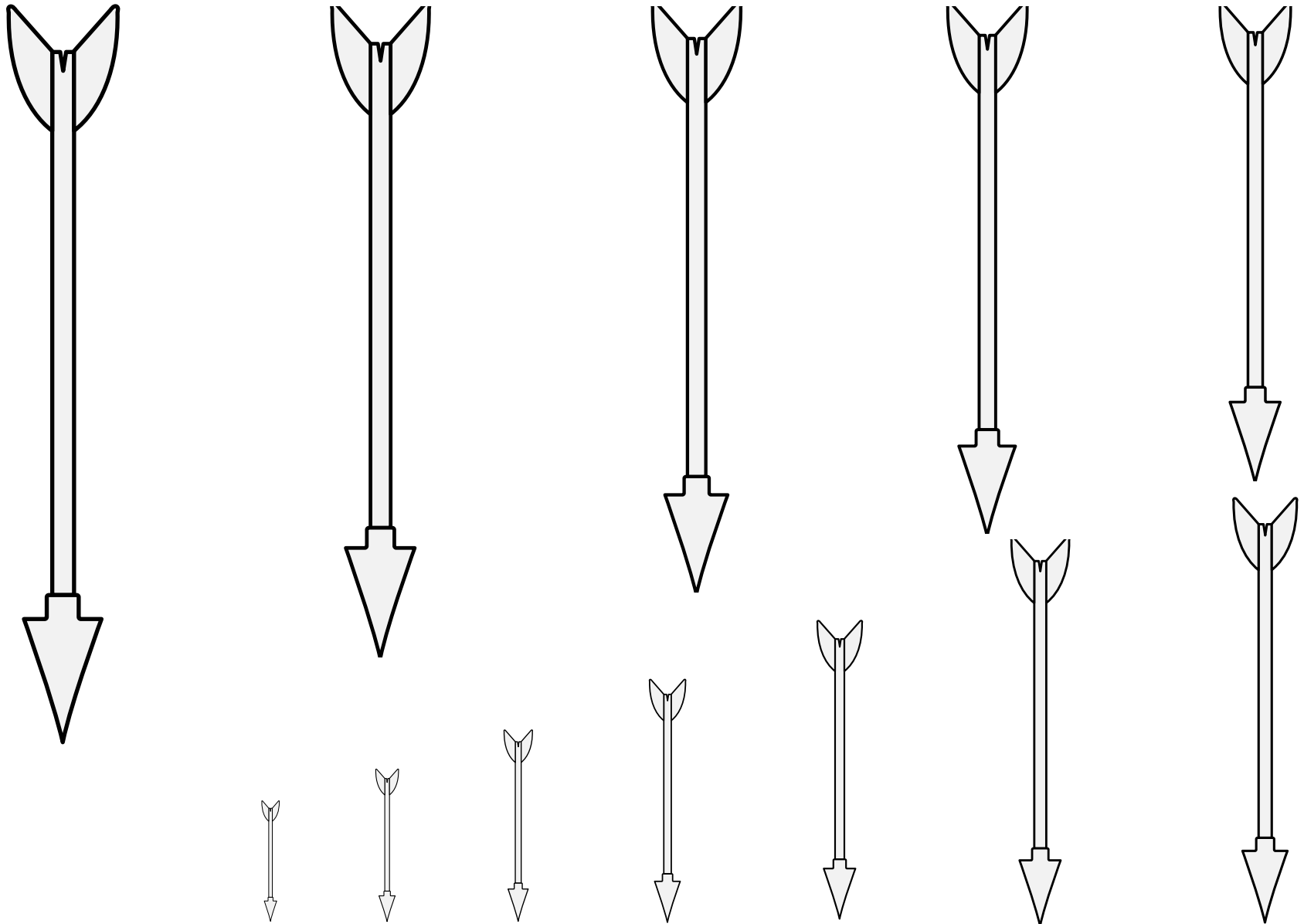

A projectile for use with a bow.

Default orientation: point to base.

Source: Pennsic Traceable Art. Artist unknown.  
Adapted by Mathghamhain Ua Ruadháin.

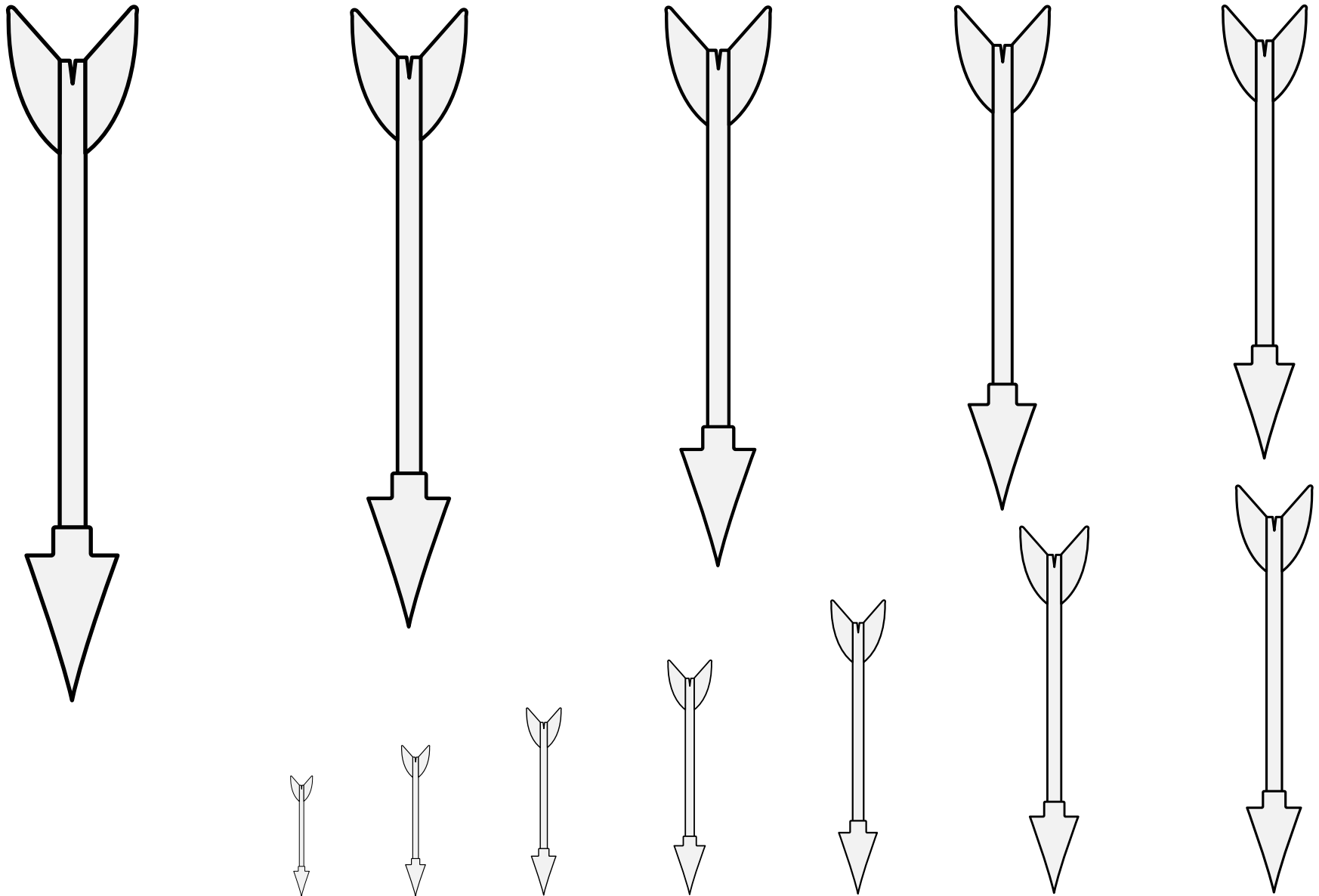

A projectile for use with a bow.

Default orientation: point to base.

Source: Pennsic Traceable Art. Artist unknown.  
Adapted by Mathghamhain Ua Ruadháin.

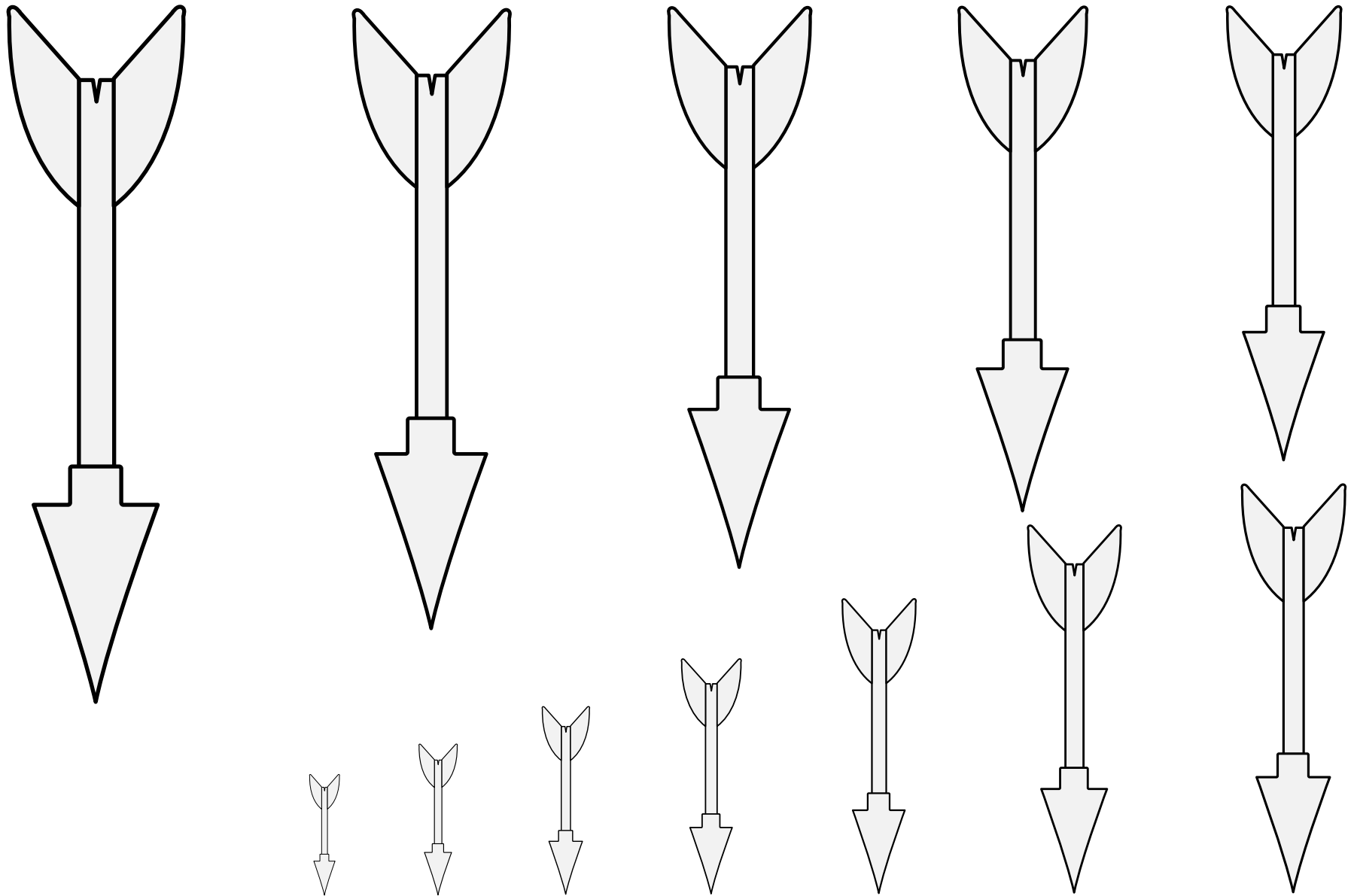

A projectile for use with a bow.

Default orientation: point to base.

Source: Pennsic Traceable Art. Artist unknown.  
Adapted by Mathghamhain Ua Ruadháin.

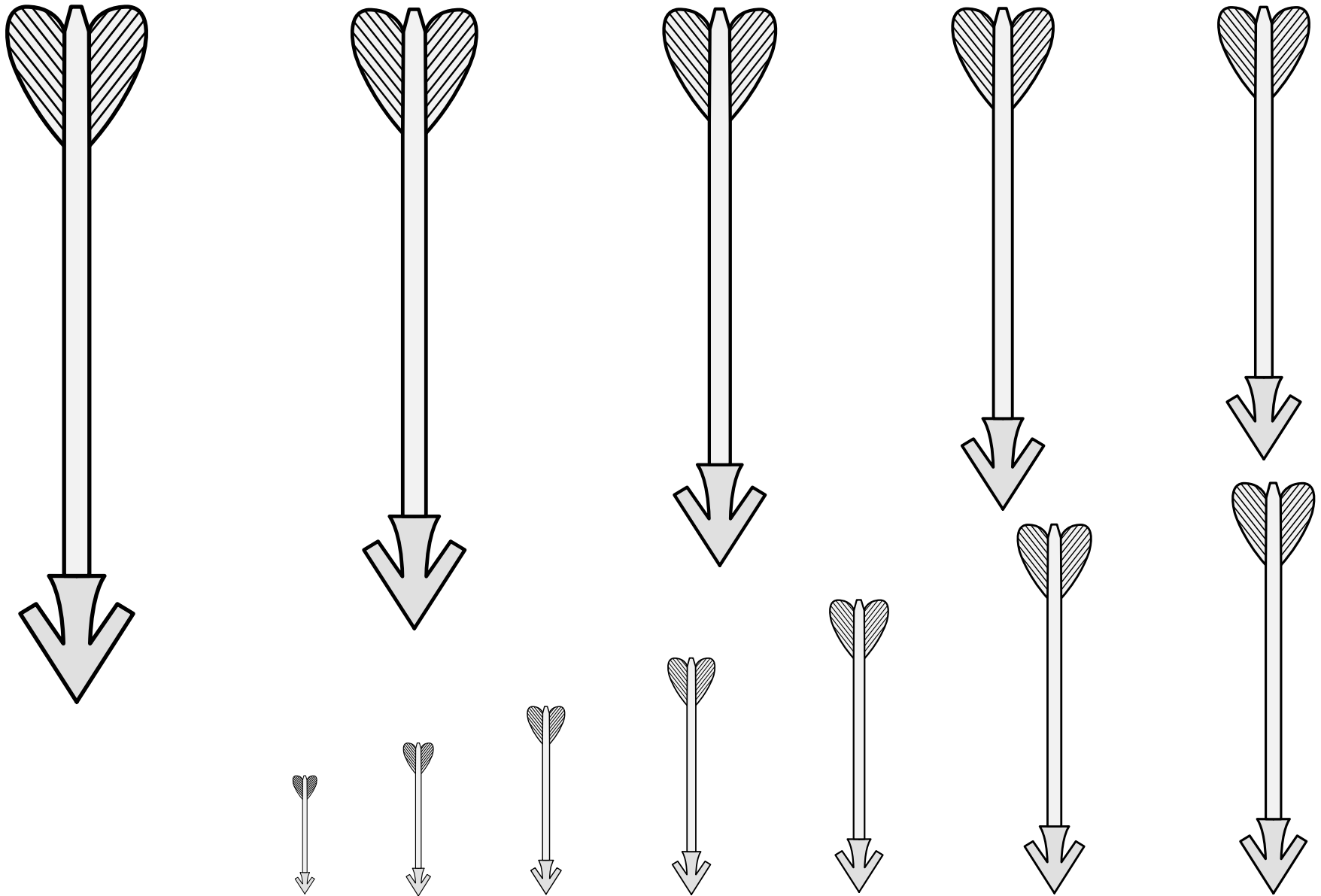

A projectile for use with a bow.

Default orientation: point to base.

Source: Sledgehammer. Artist: Grimwulf Harland.

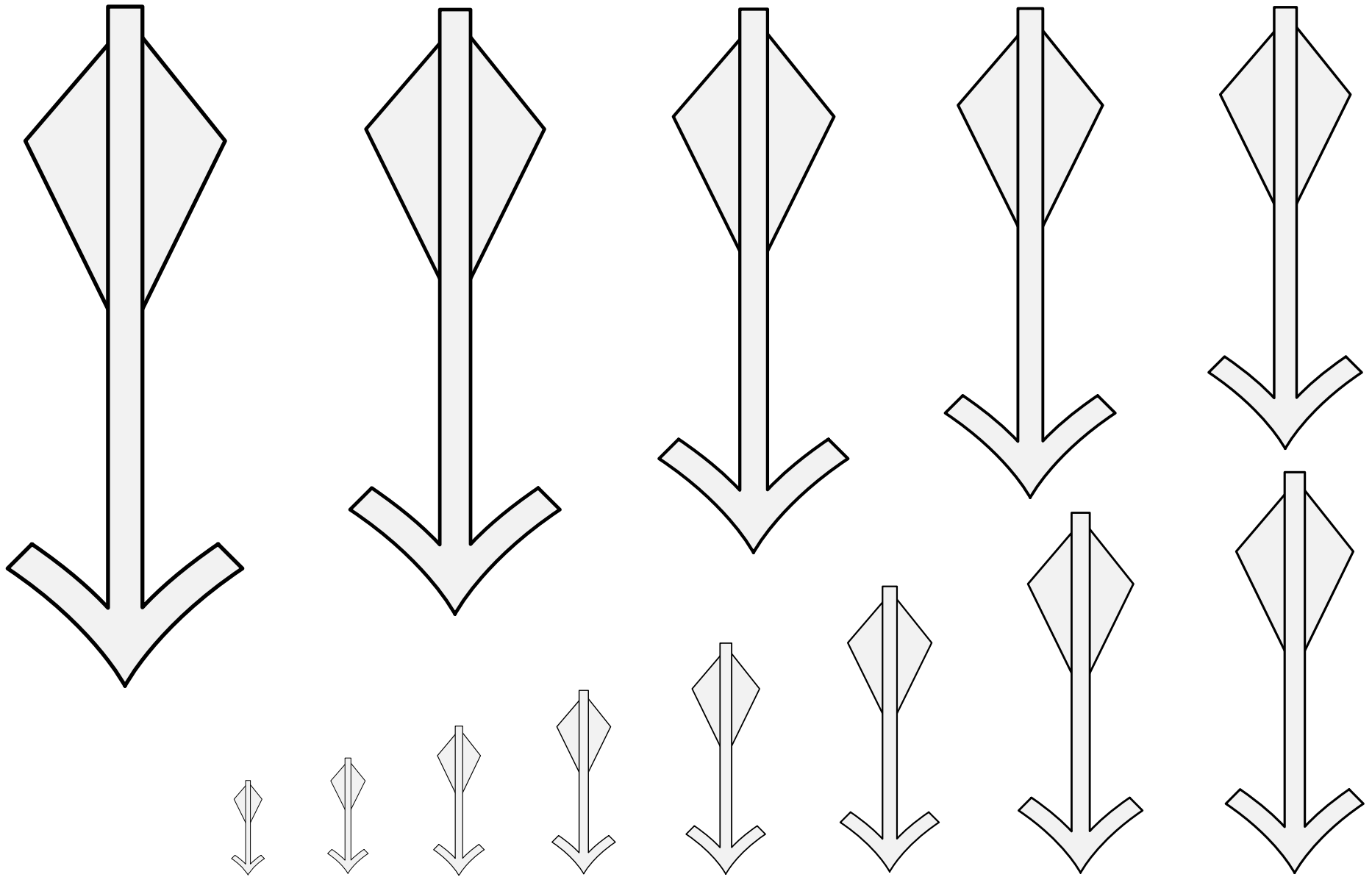

A projectile for use with a bow.

Default orientation: point to base.

Source: Wappenbuch der Arlberg-Bruderschaft. Artist: Vigil Raber.

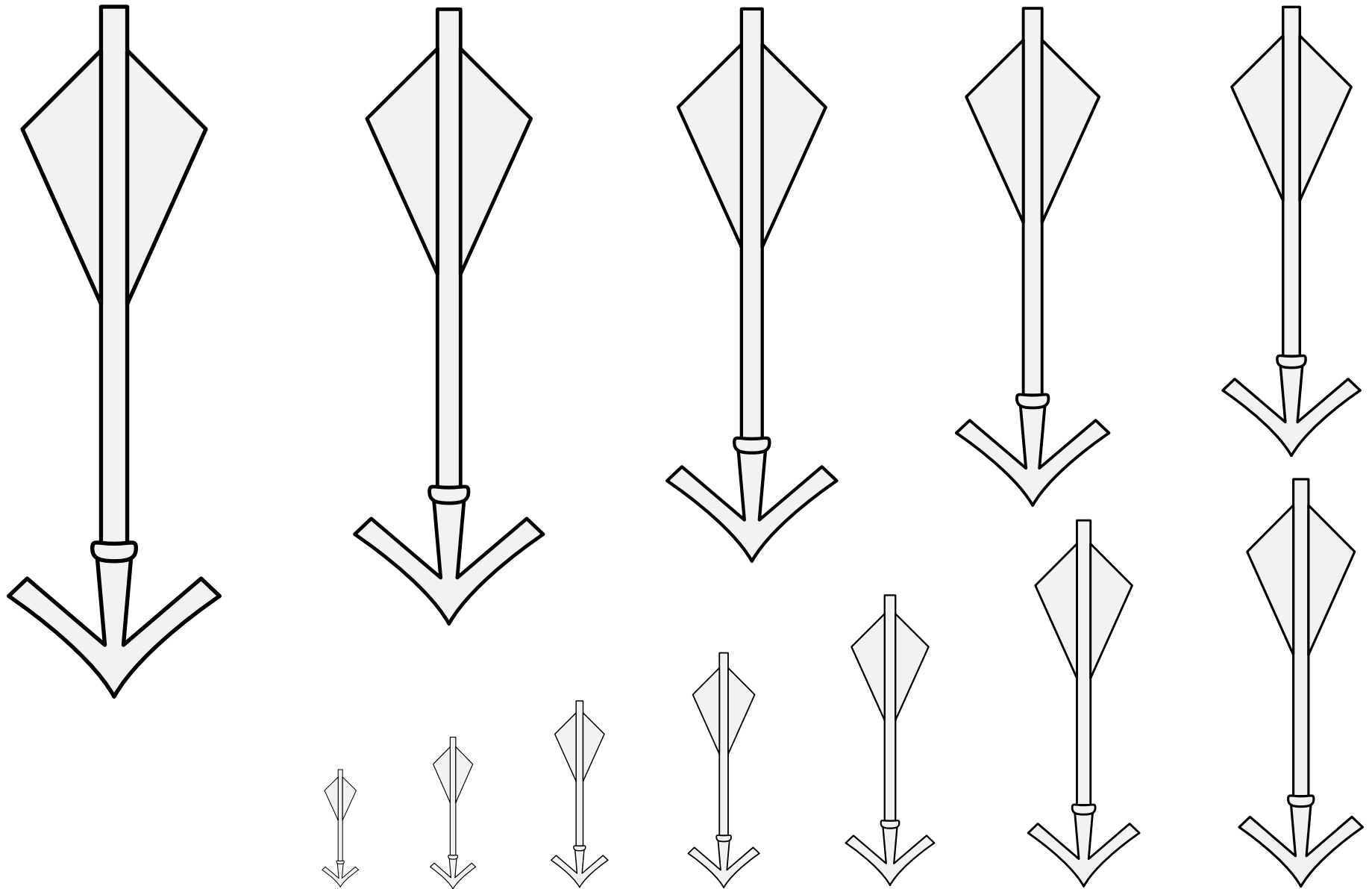

A projectile for use with a bow.

Default orientation: point to base.

Source: Wappenbuch der Arlberg-Bruderschaft. Artist: Vigil Raber. (Folio 7.)

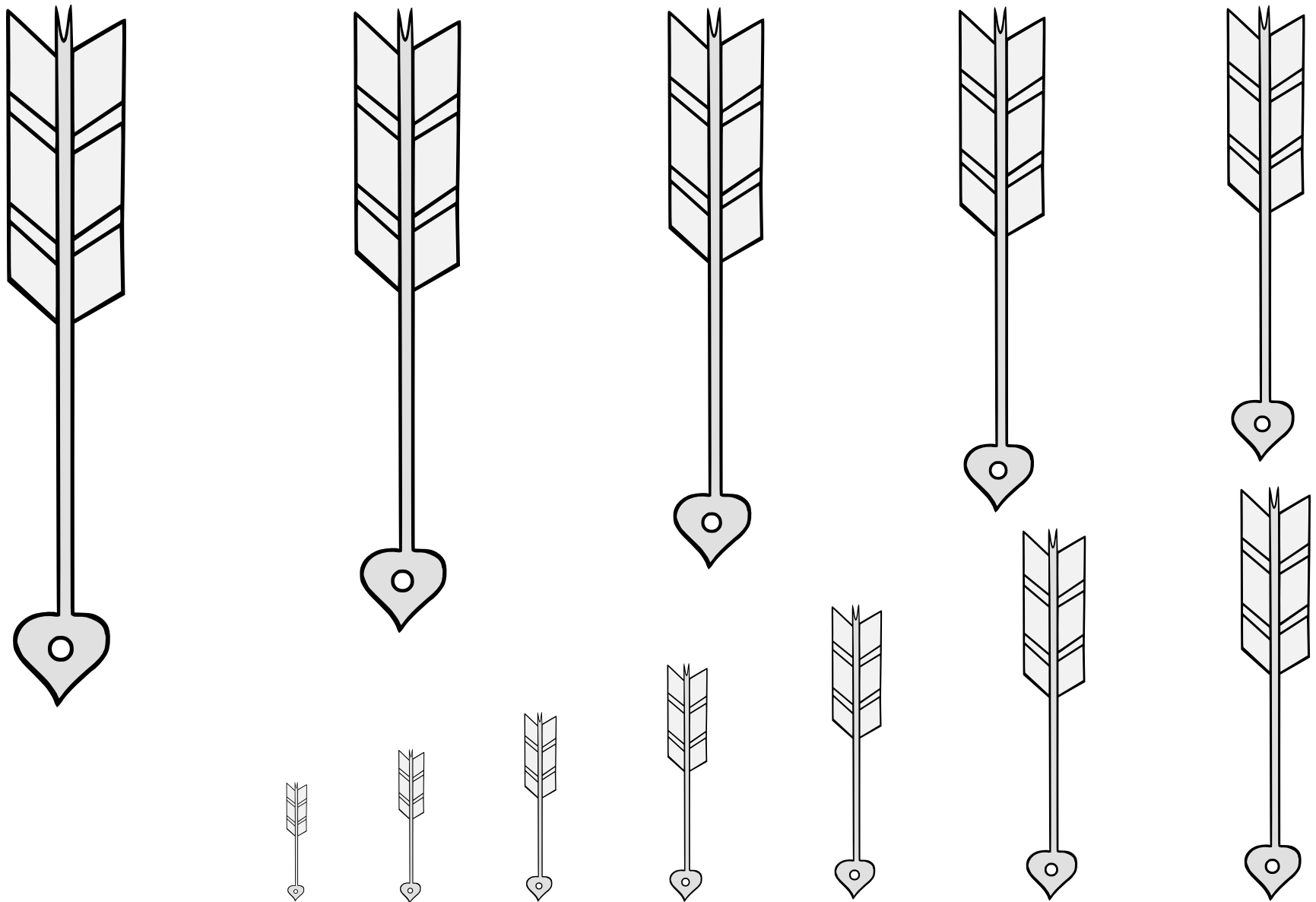

A projectile for use with a bow.

Default orientation: point to base.

Source: Kenmon Shokamon. Artist unknown. (Page 45.)

Adapted by Jessimond of Emerickeskepe.



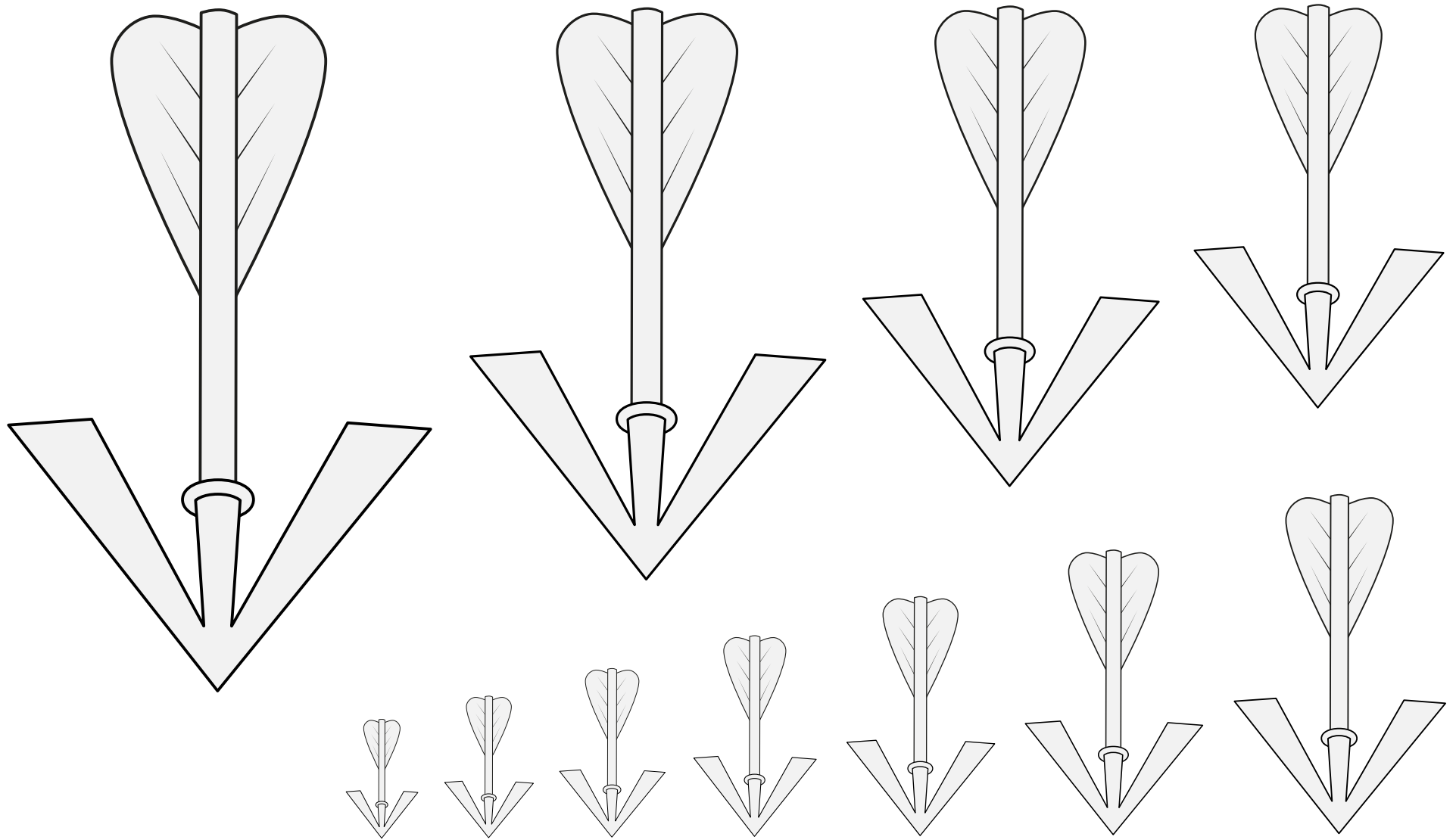

A projectile for use with a bow.

Default orientation: point to base.

Source: WappenWiki. Artist: Joakim Spuller.

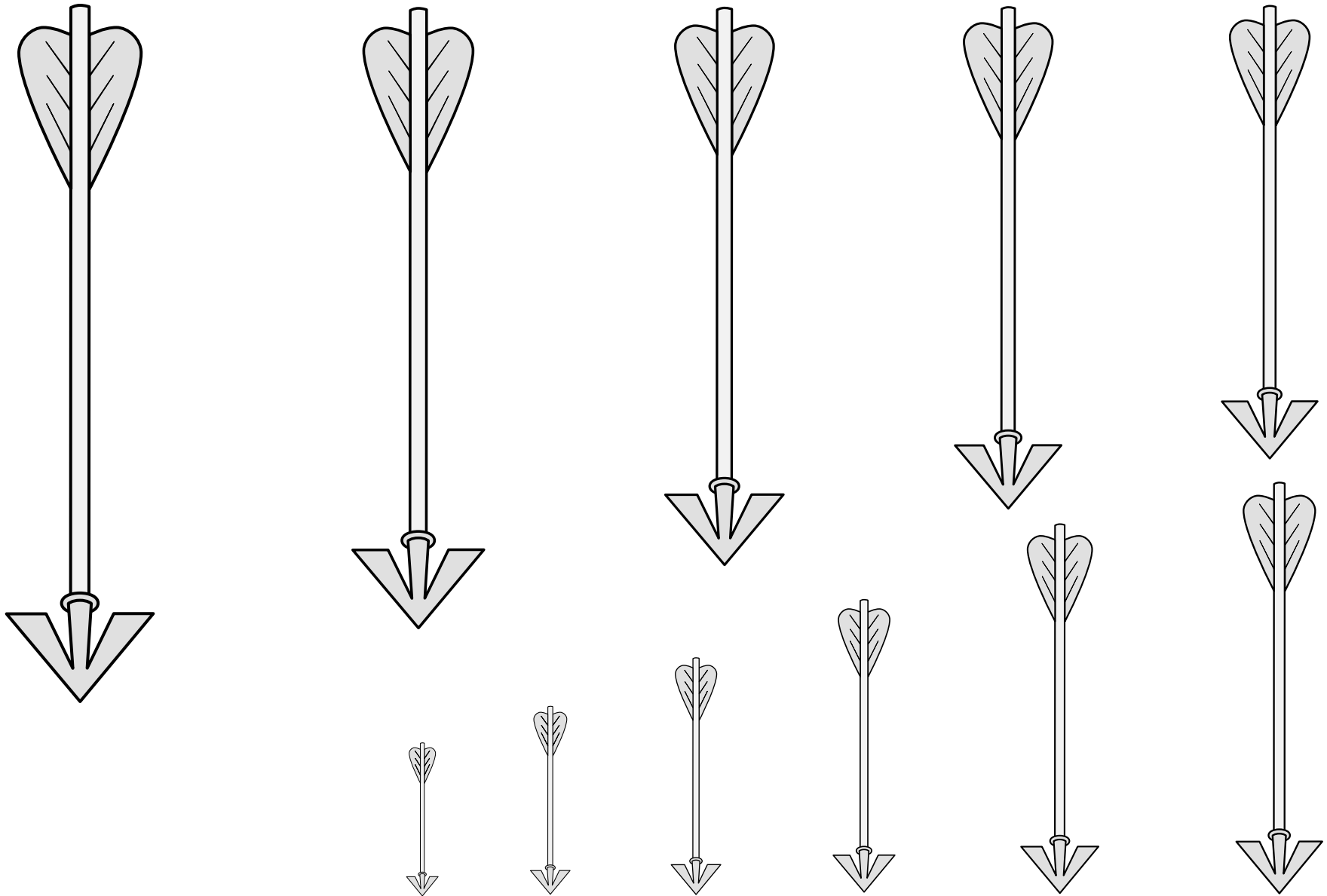

A projectile for use with a bow.

Default orientation: point to base.

Source: WappenWiki. Artist: Joakim Spuller.

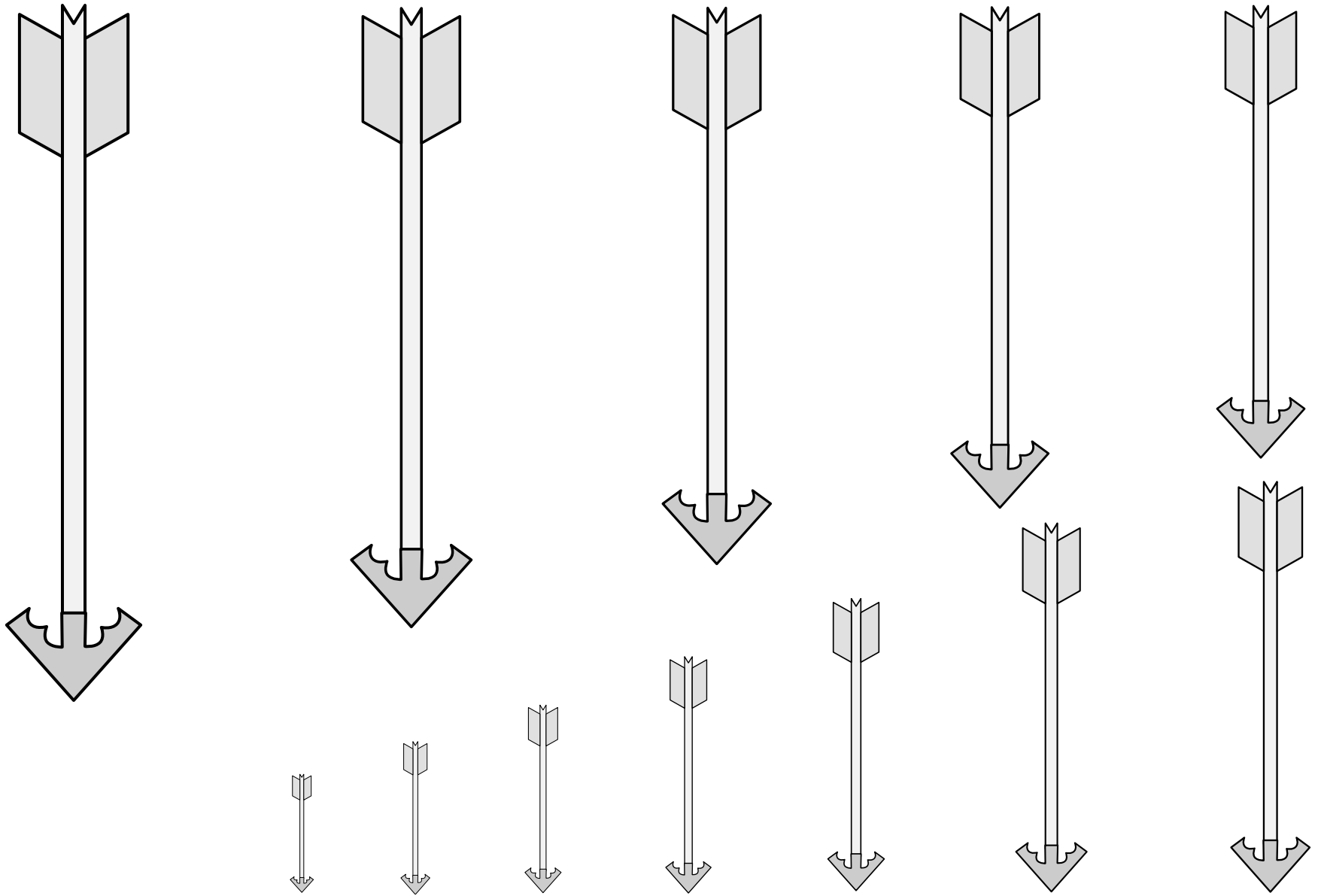

A projectile for use with a bow.

Default orientation: point to base.

Source: Pennsic 50 Art Tent. Artist: Pennsic 50 Volunteer.

**Arrow (12)** 21.15

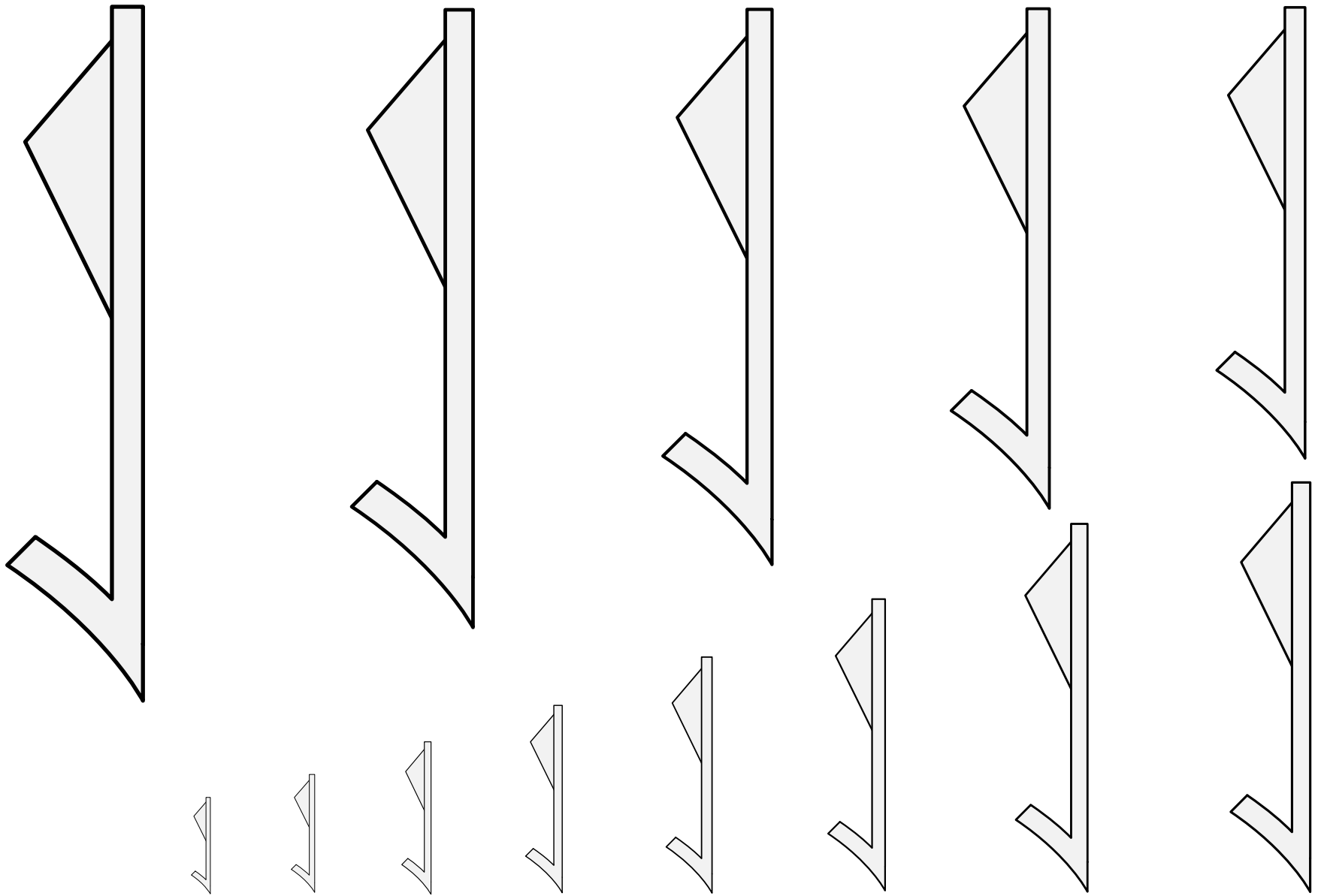

A projectile for use with a bow.

Default orientation: point to base.

Source: Wappenbuch der Arlberg-Bruderschaft. Artist: Vigil Raber.

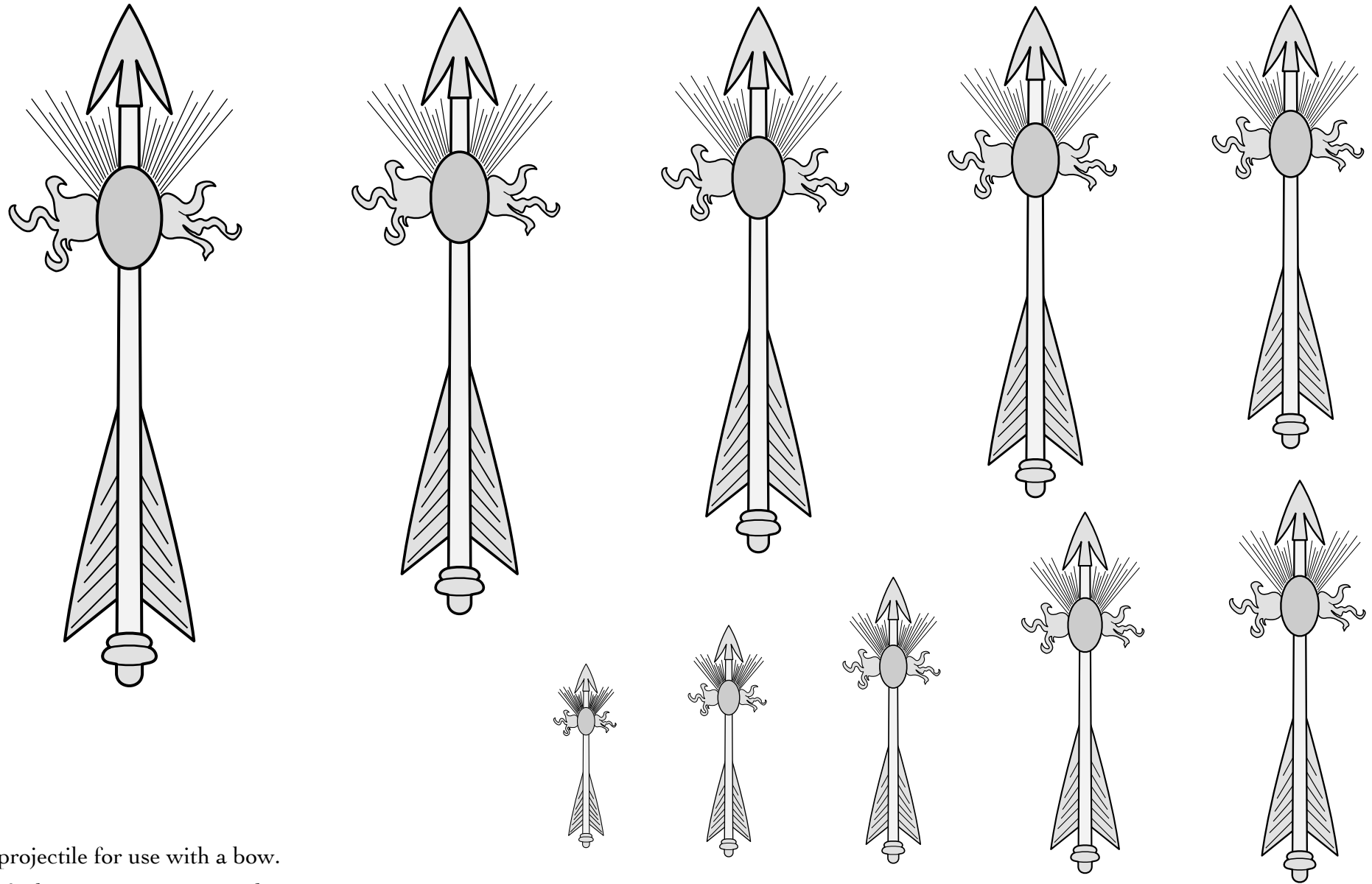

A projectile for use with a bow.

Default orientation: point to base.

The firework arrow has an incendiary affixed to its shaft.

Source: A Display of Heraldry. Artist: John Guillim.  
(Manuscript folio 95r.) Adapted by Iago ab Adam.

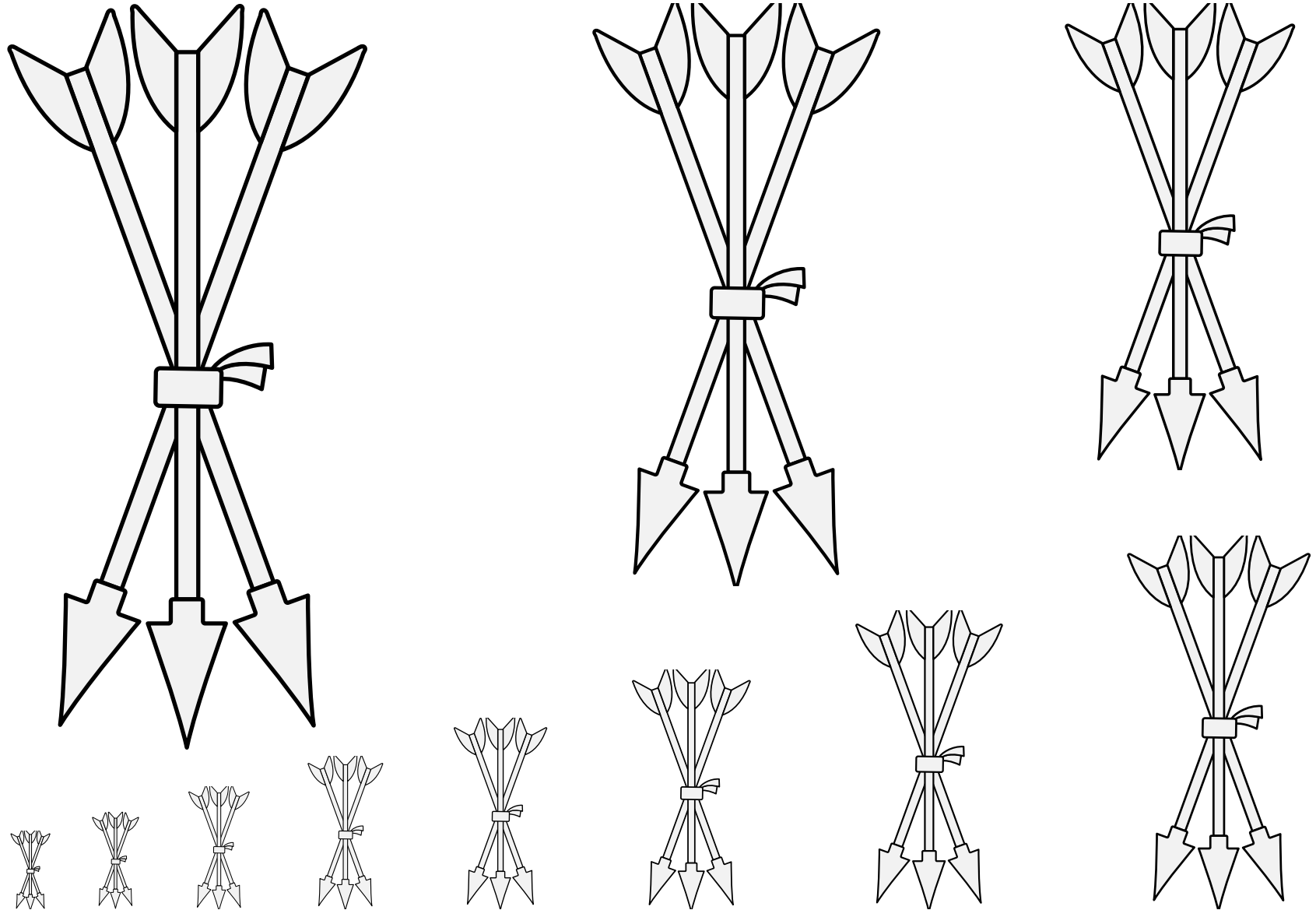

A projectile for use with a bow.

Default orientation: point to base. No proper coloration.

Source: Pennsic Traceable Art. Artist unknown.  
Adapted by Mathghamhain Ua Ruadháin.

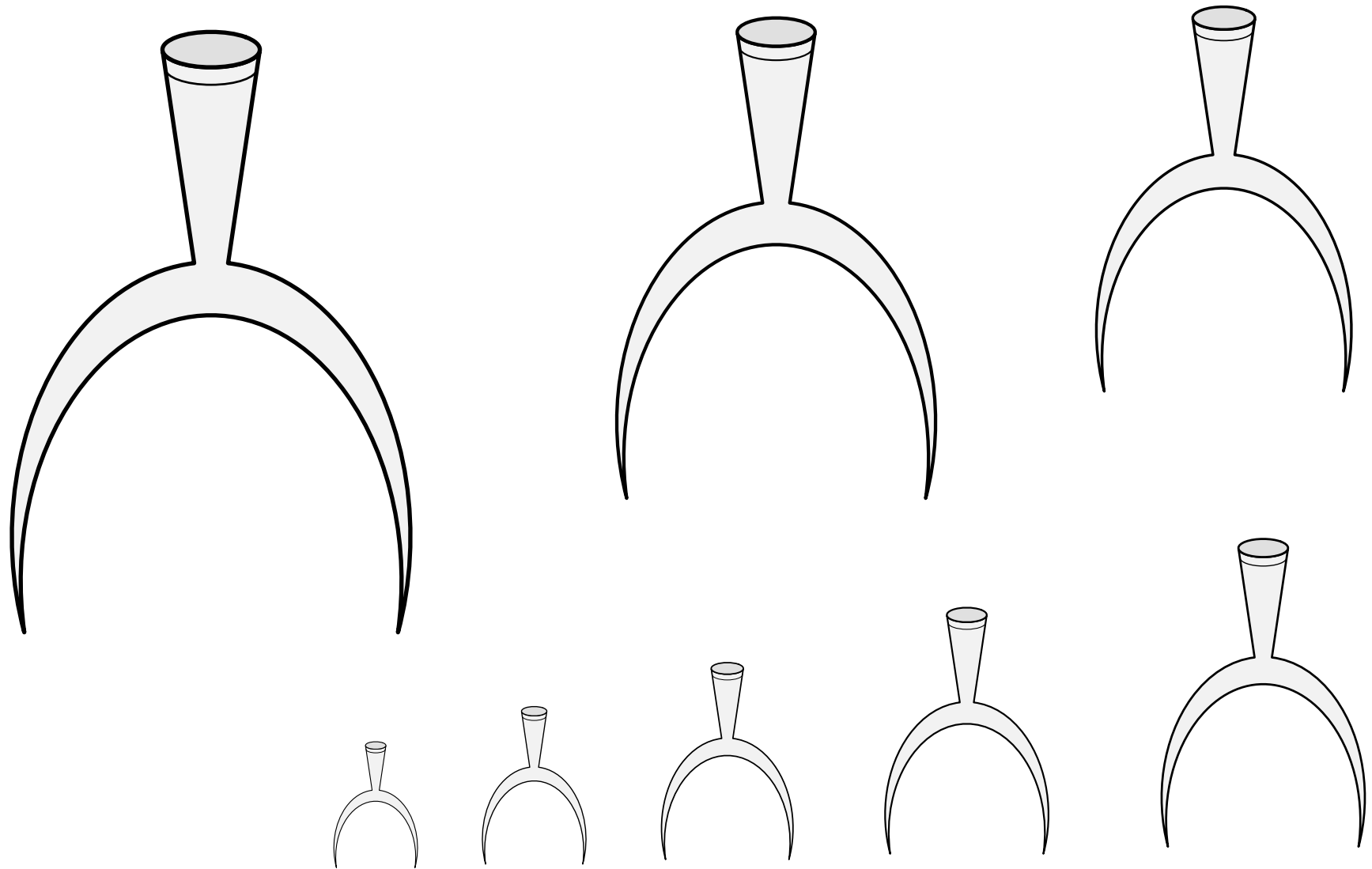

An arrowhead with two points.

Default orientation: point to base. No proper coloration.

Source: Wappenbuch der Arlberg-Bruderschaft.  
Artist: Vigil Raber. (Arms of Hande.)

**Arrowhead, Crescent-Shaped** 21.19

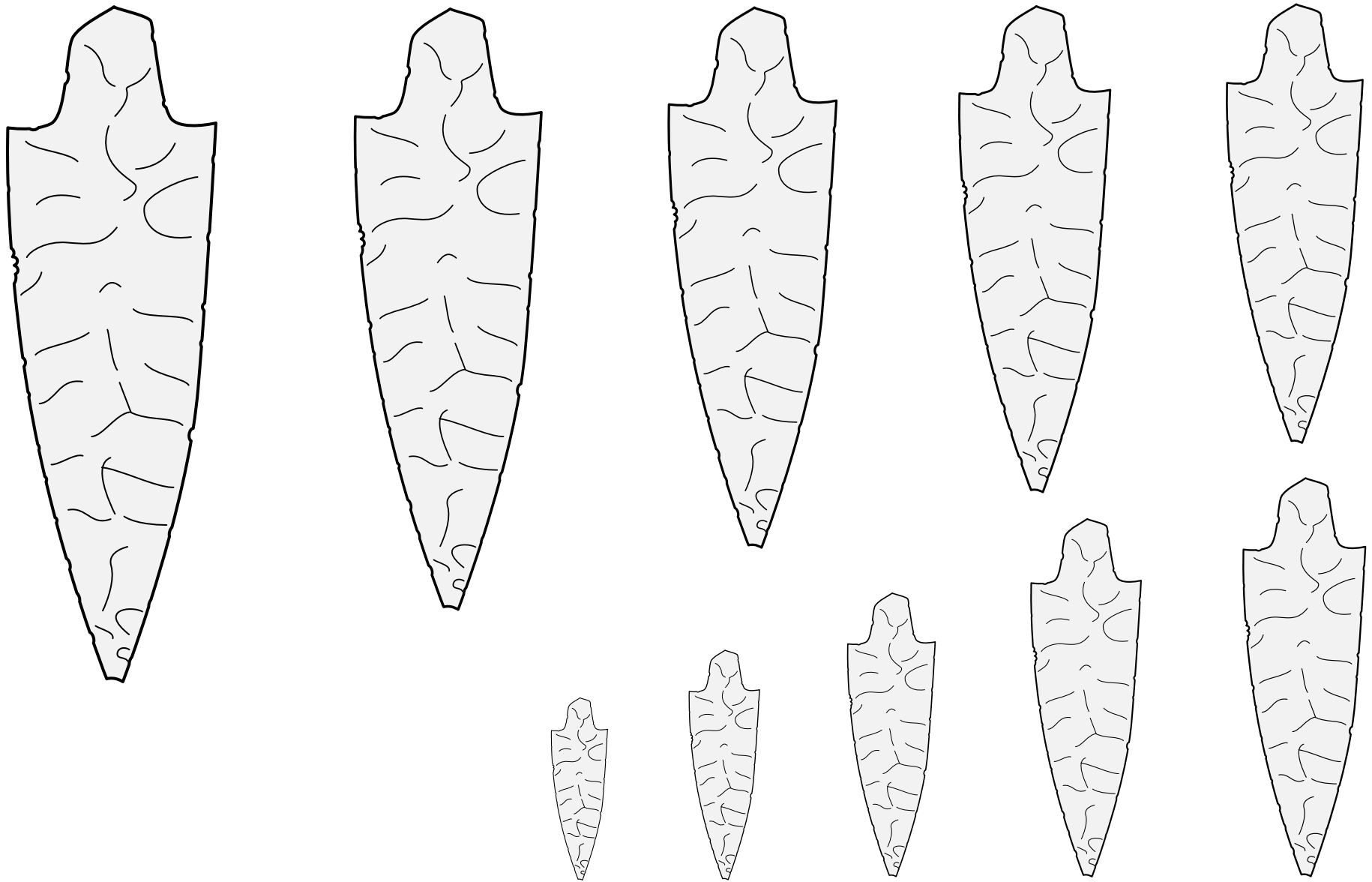

A projectile point made out of knapped stone.

Default orientation: point to base. No proper coloration.

Source: Met Museum. (Object 08.99.1, Italian, circa 5000 – 10,000 BCE.)

**Arrowhead, Stone** 21.20



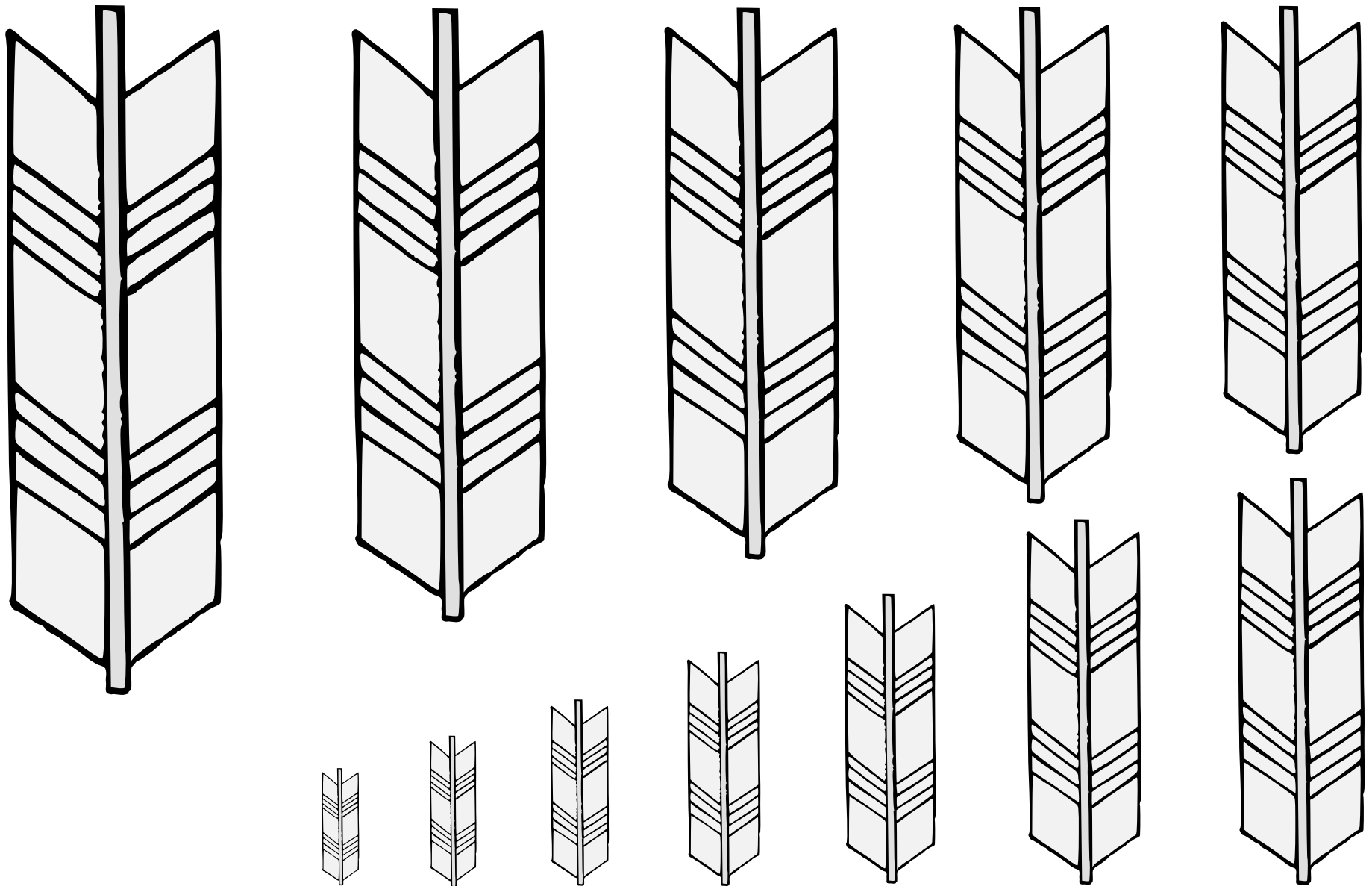

A set of feathers affixed to a shaft to guide the flight of an arrow.  
Default orientation: palewise, point to base. No proper coloration.  
Source: Kenmon Shokamon. Artist unknown. (Page 39.)

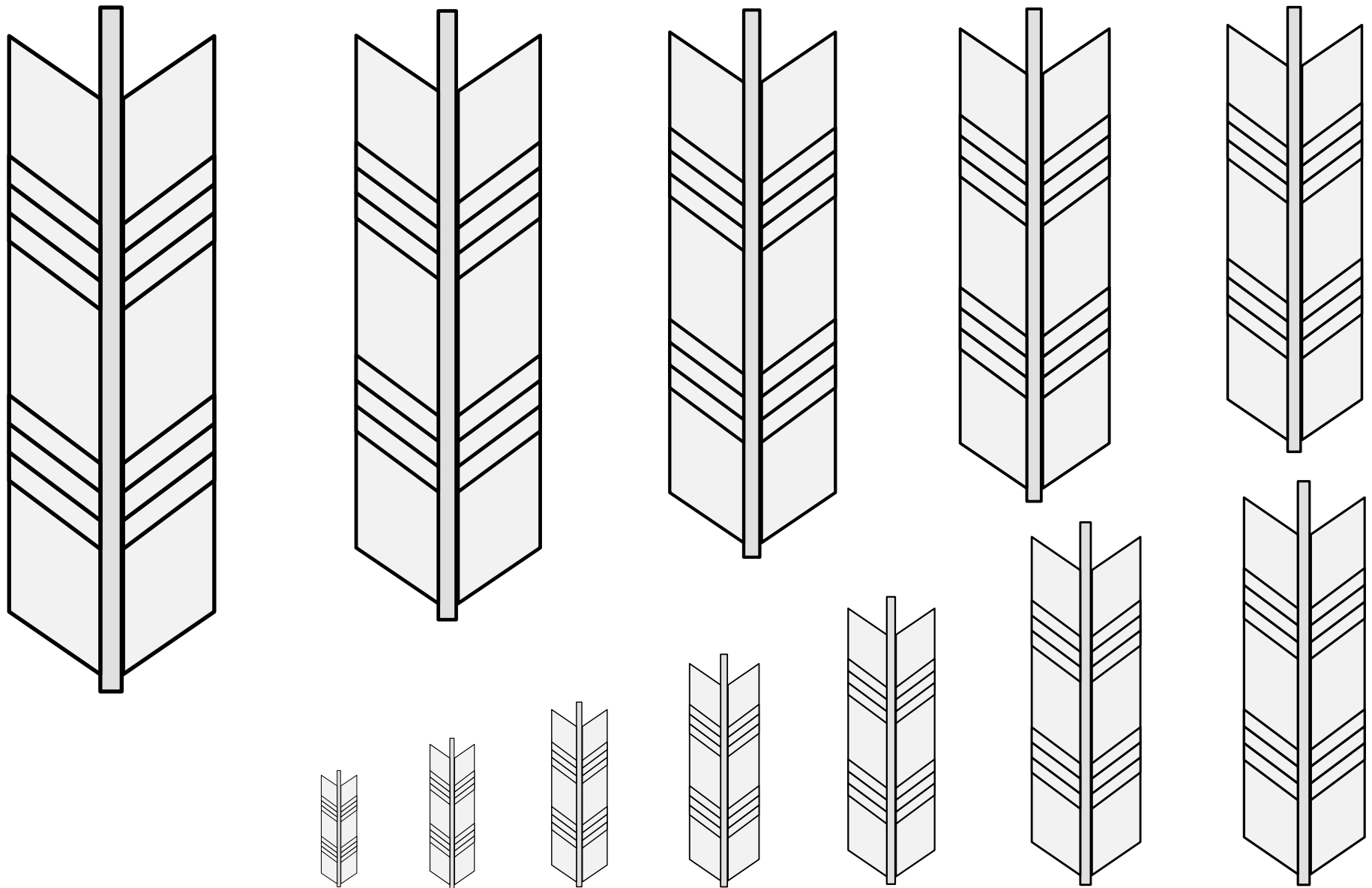

A set of feathers affixed to a shaft to guide the flight of an arrow.  
Default orientation: palewise, point to base. No proper coloration.  
Source: Kenmon Shokamon. Artist unknown. (Page 39.)

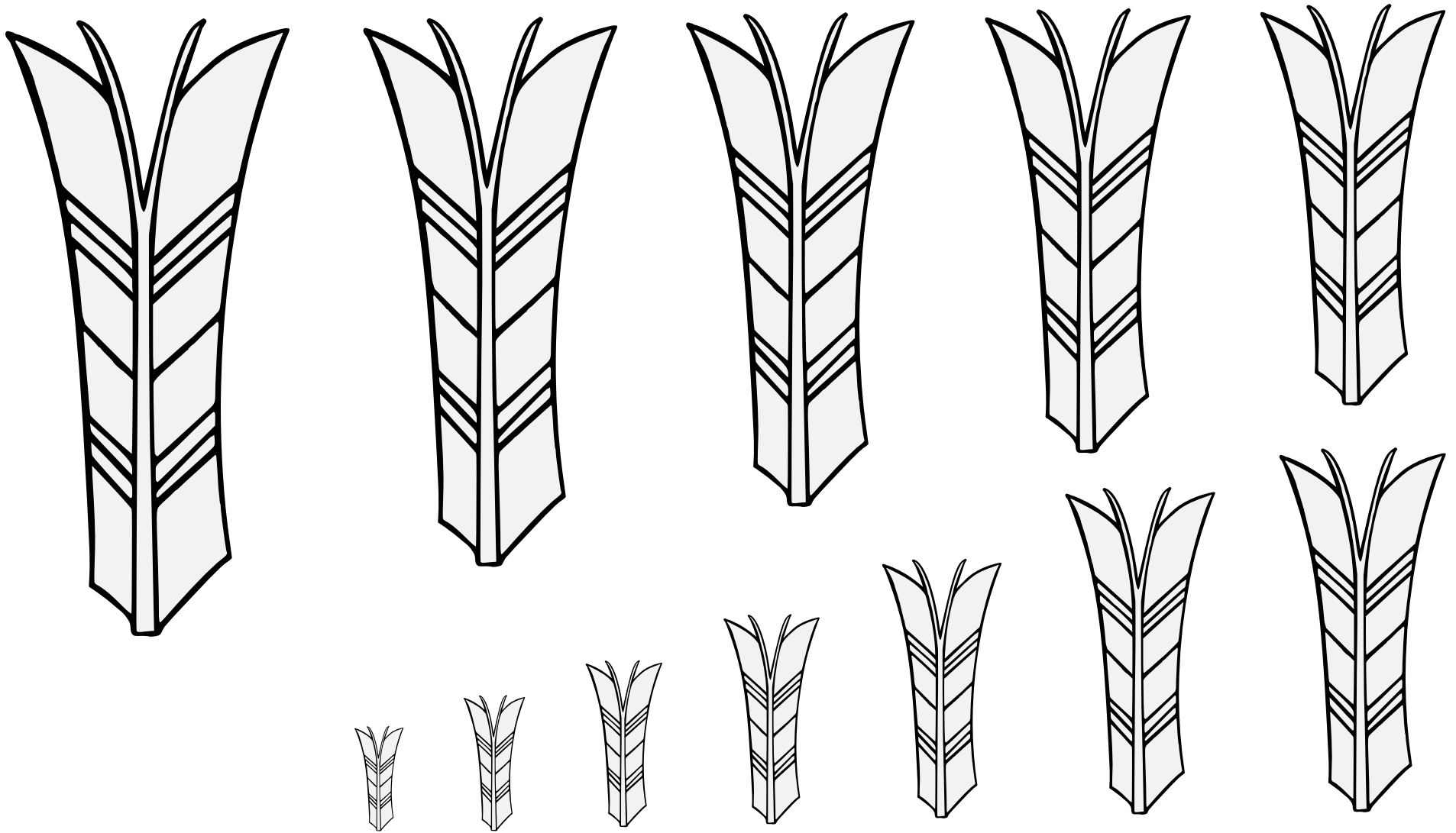

A set of feathers affixed to a shaft to guide the flight of an arrow.

Default orientation: palewise, point to base. No proper coloration.

Source: Kenmon Shokamon. Artist unknown. (Page 38.)

Adapted by Jessimond of Emerickeskepe.

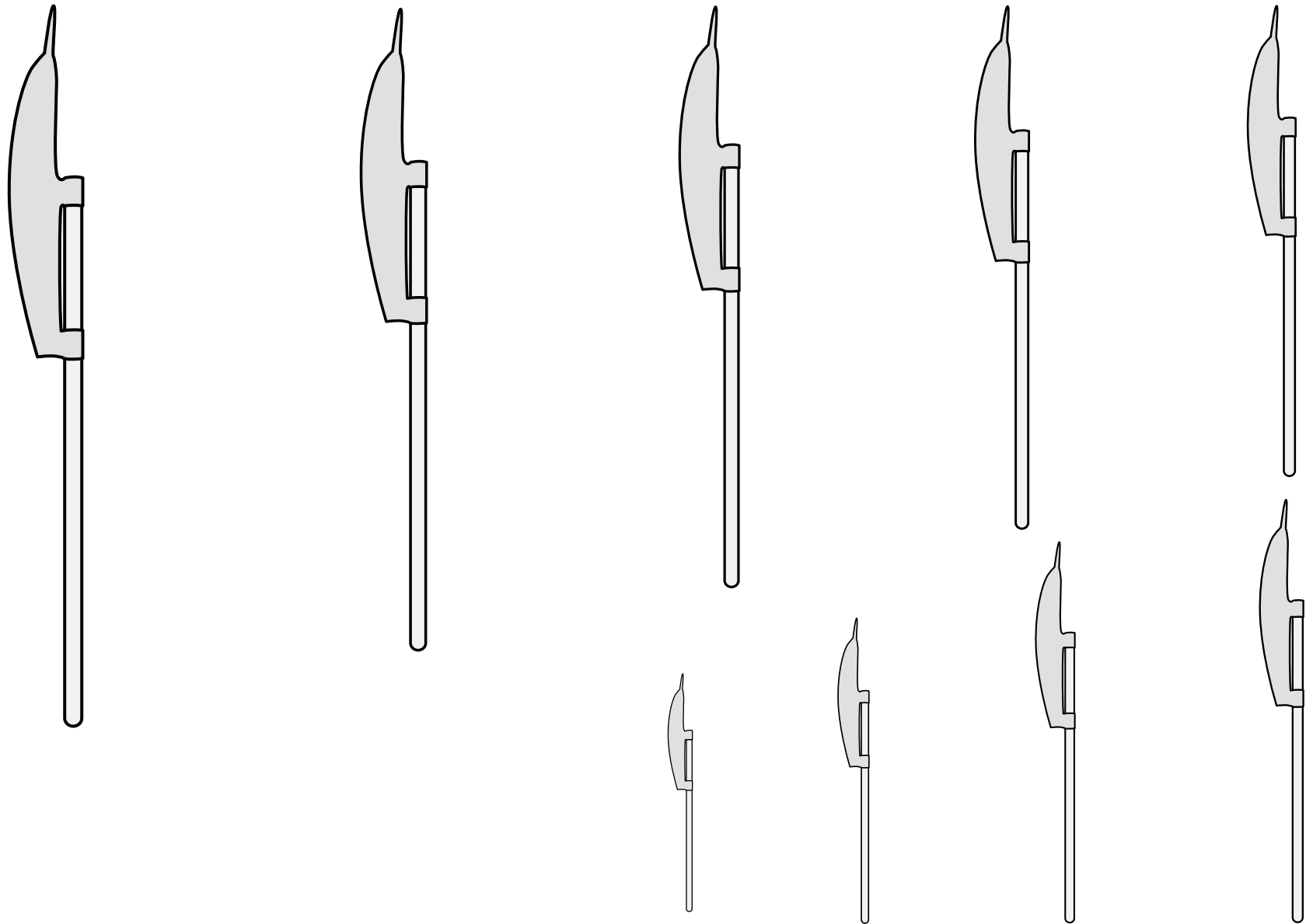

A specialized type of war axe, with a long blade joined to its shaft in two places.  
Default alignment: palewise, point to chief, cutting to dexter. No proper coloration.

**Axe, Bardiche** • 21.24

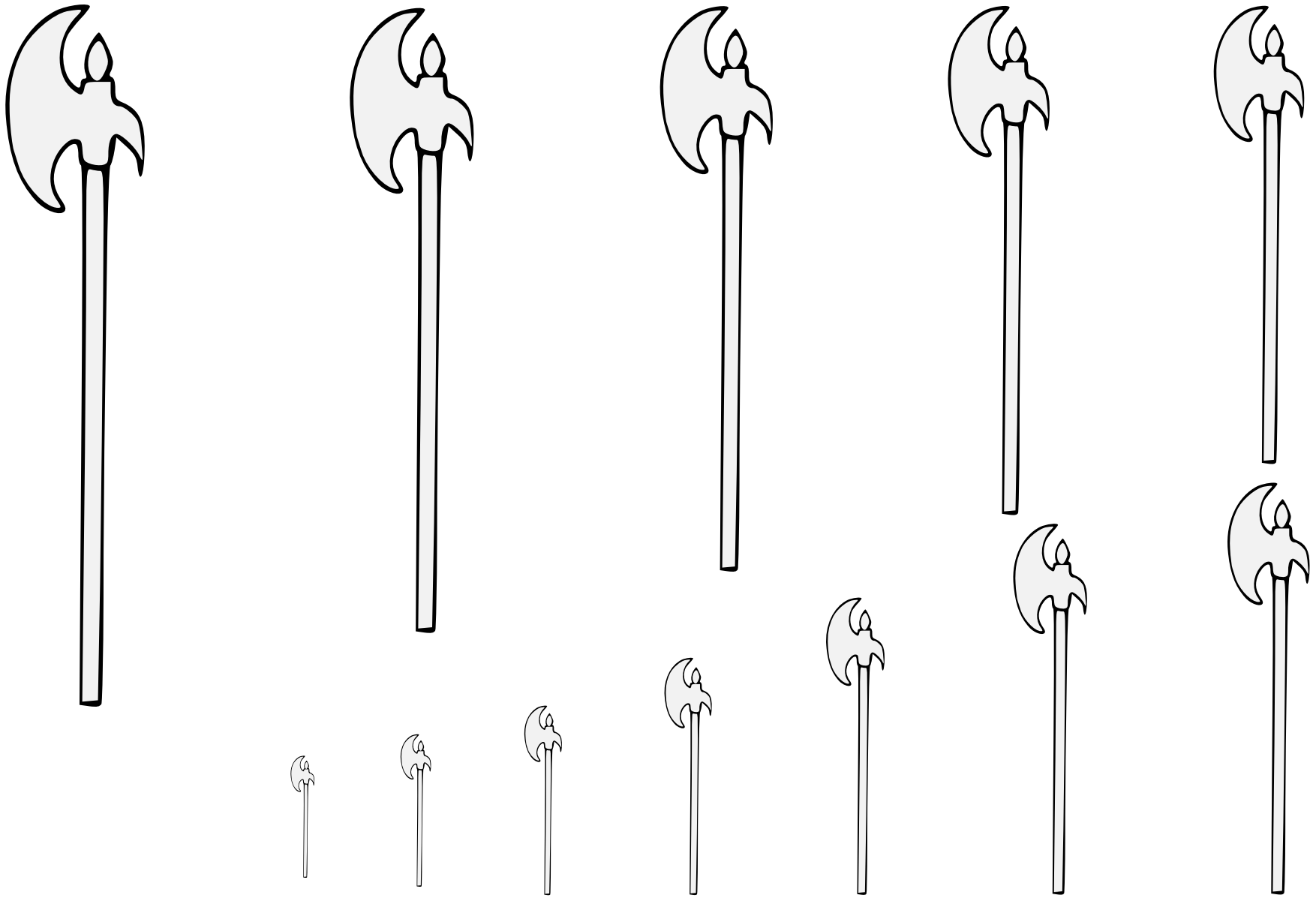

A sharp blade attached to a wooden shaft. This is a battle axe with an long haft.  
Default orientation: handle to base, blade to dexter.  
Source: Pennsic Traceable Art. Artist unknown.

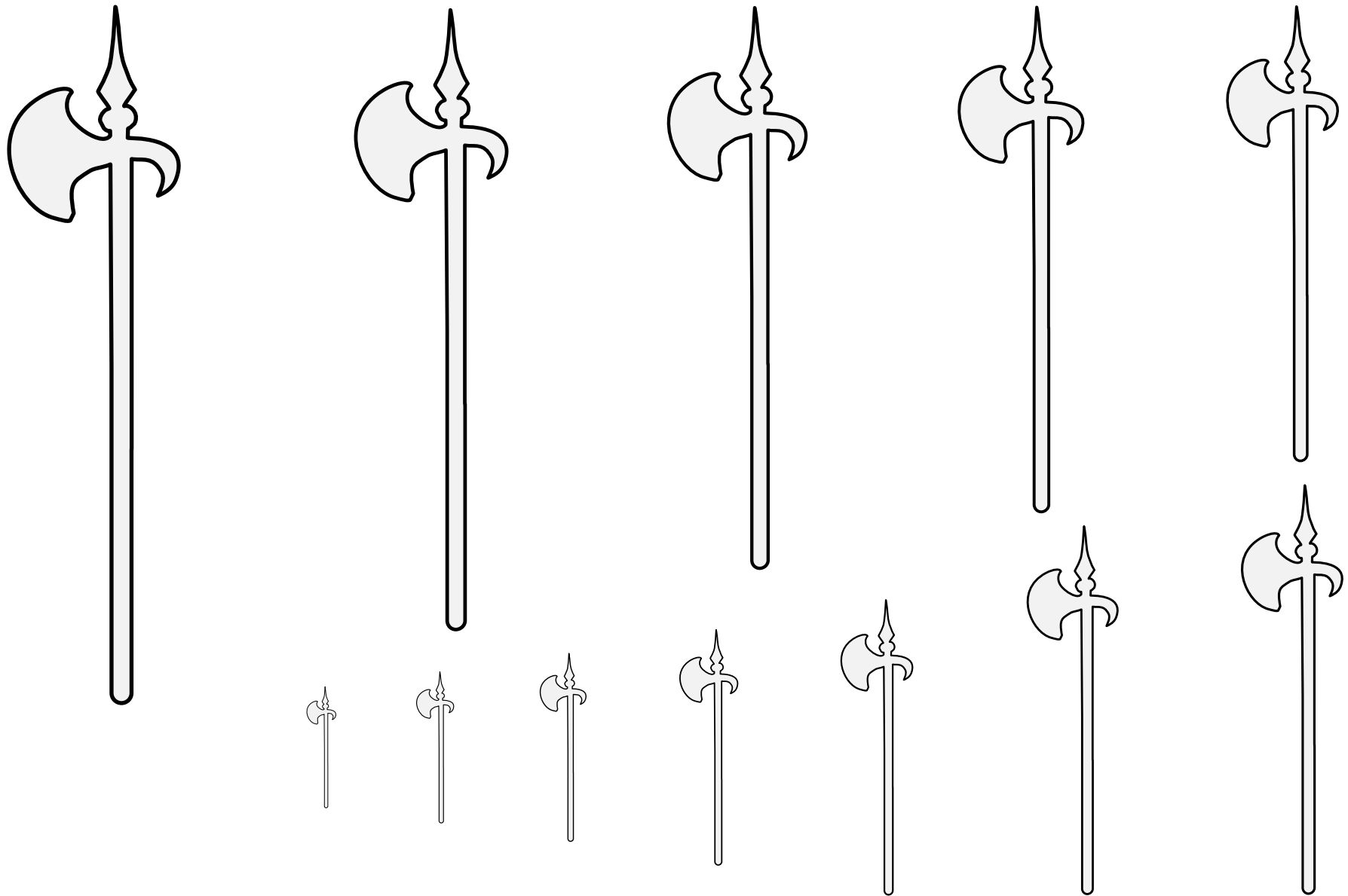

A sharp blade attached to a wooden shaft. This is a battle axe with an long haft.

Default orientation: handle to base, blade to dexter.

Source: Wikimedia Commons. Artist: Mouagip. Adapted from the coat of arms of the city of Yaroslavl. License: Public domain.

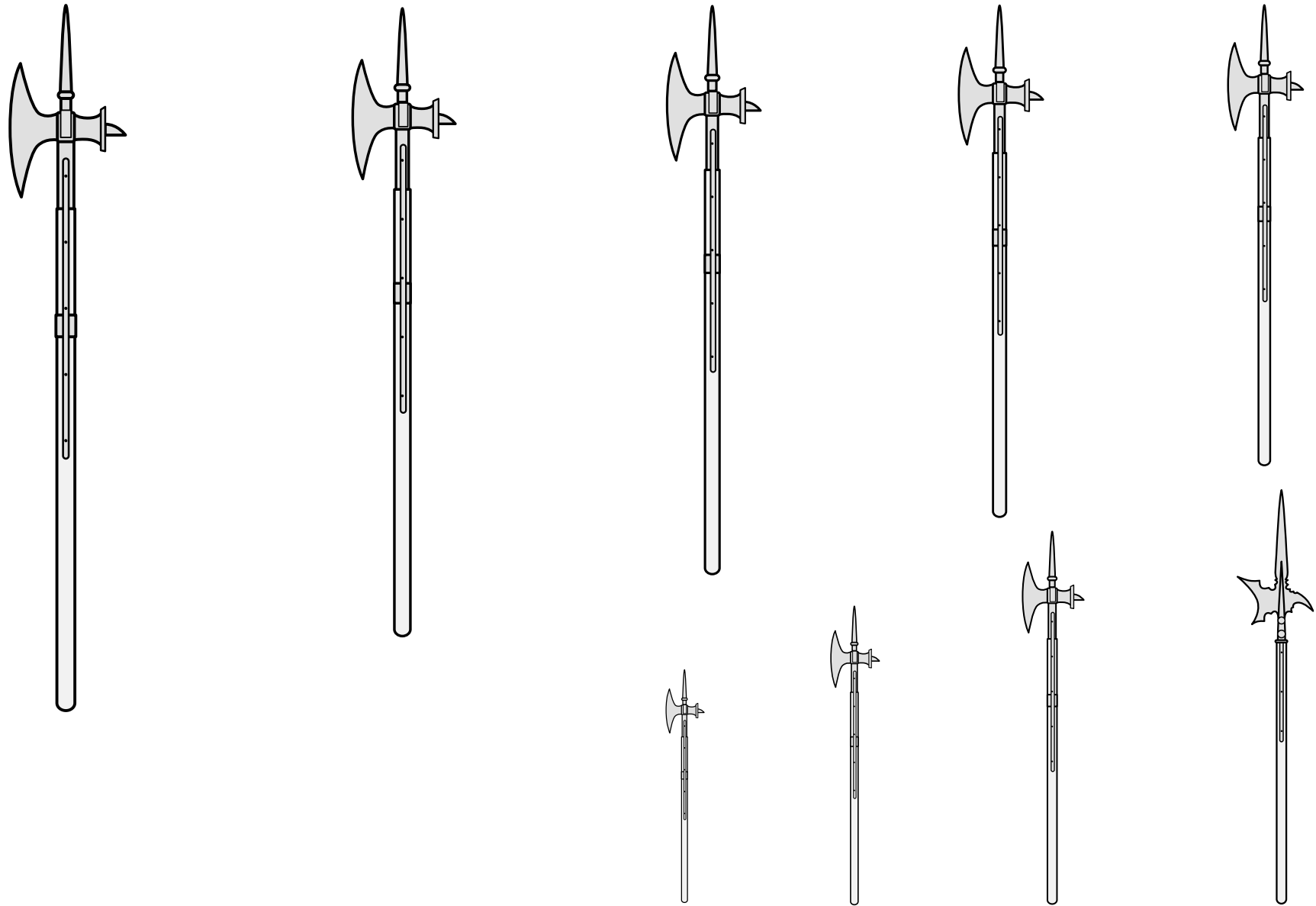

A sharp blade attached to a wooden shaft. This is a battle axe with an long haft.  
Default orientation: point to chief, cutting to dexter. No proper coloration.

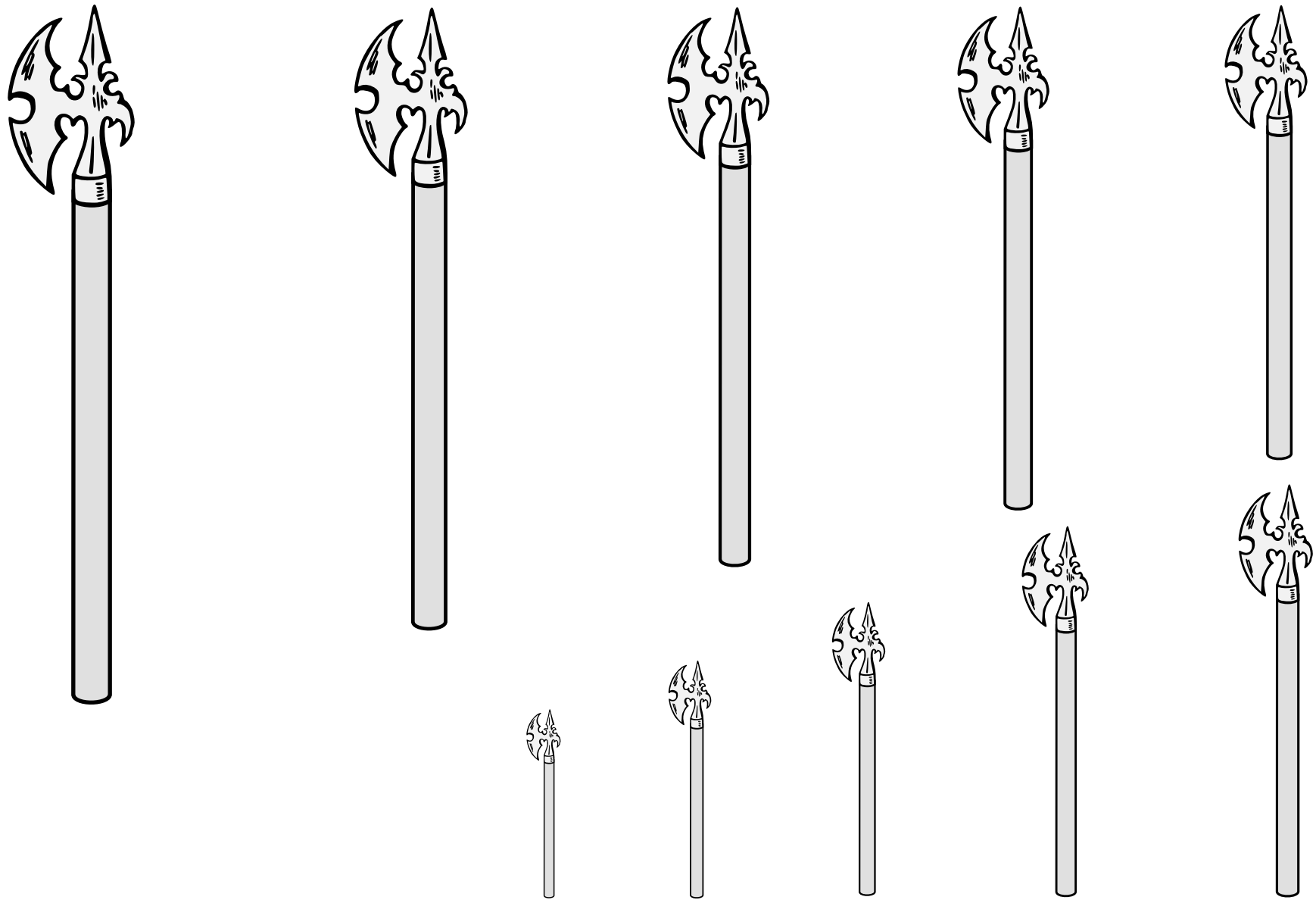

A sharp blade attached to a wooden shaft. This is a battle axe with an long haft.

Default orientation: handle to base, blade to dexter.

Source: Vocabulaire-Atlas Héraldique. Artist unknown. (Illustration 492.)

**Axe, Pole (4) 21.28**



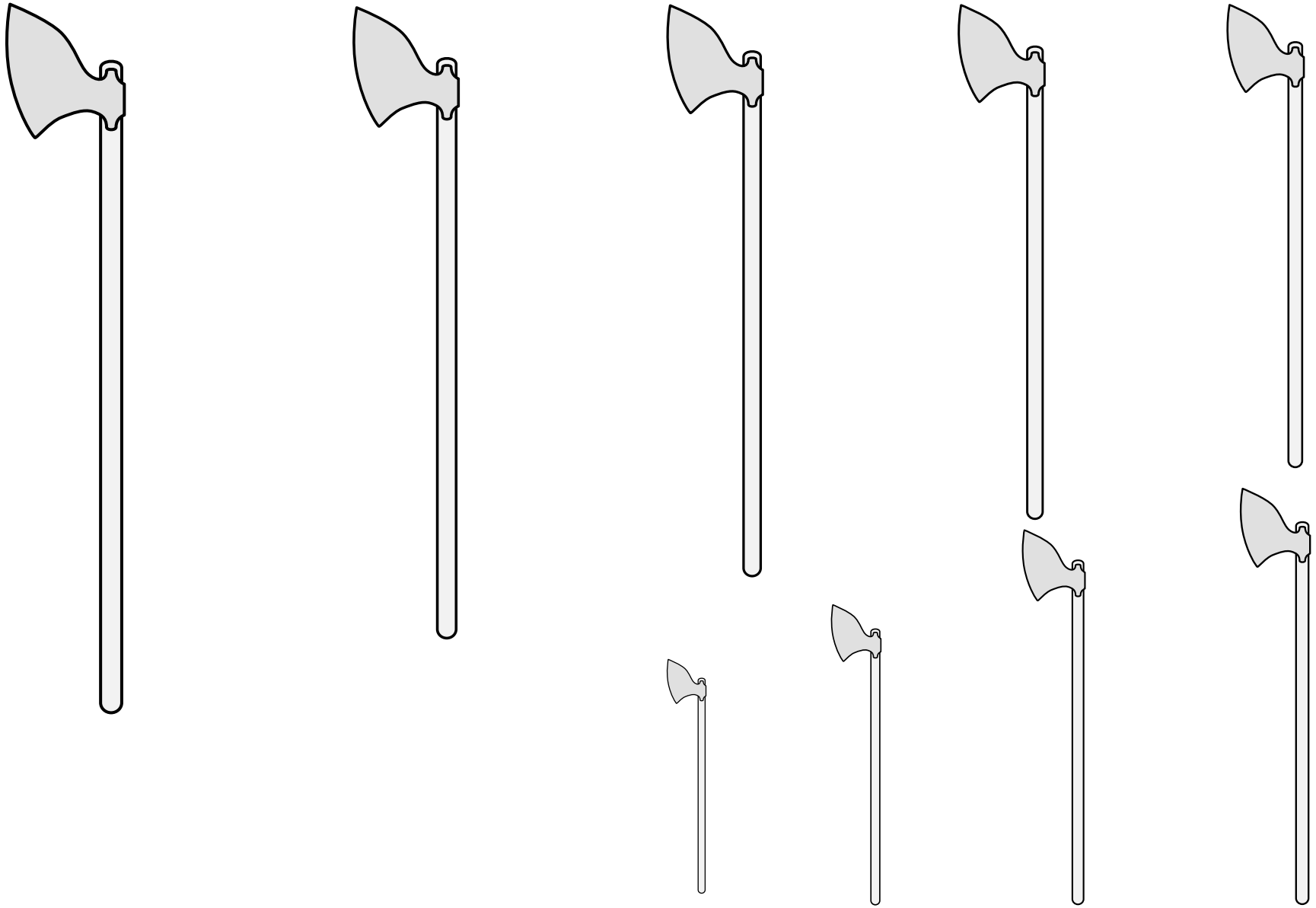

A specialized type of war axe, with a curved blade and stabbing point on a very long haft.  
Default alignment: palewise, point to chief, cutting to dexter. No proper coloration.

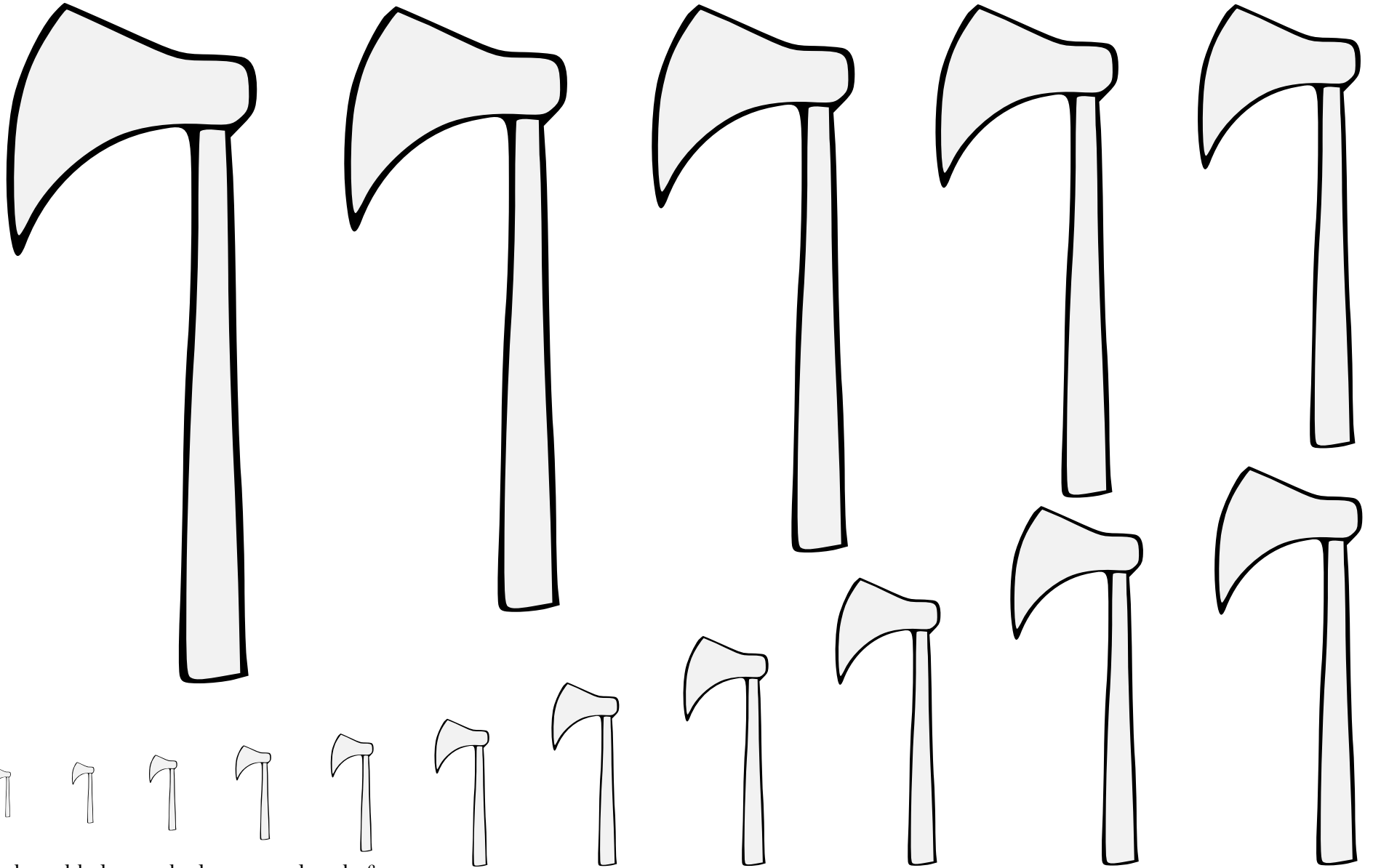

A sharp blade attached to a wooden shaft.

This is a smaller axe intended for throwing, which may be blazoned a “francisca” or “francisque.”

Default orientation: handle to base, blade to dexter.

Source: Pennsic Traceable Art. Artist unknown.

**Axe, Throwing (1) 21.30**

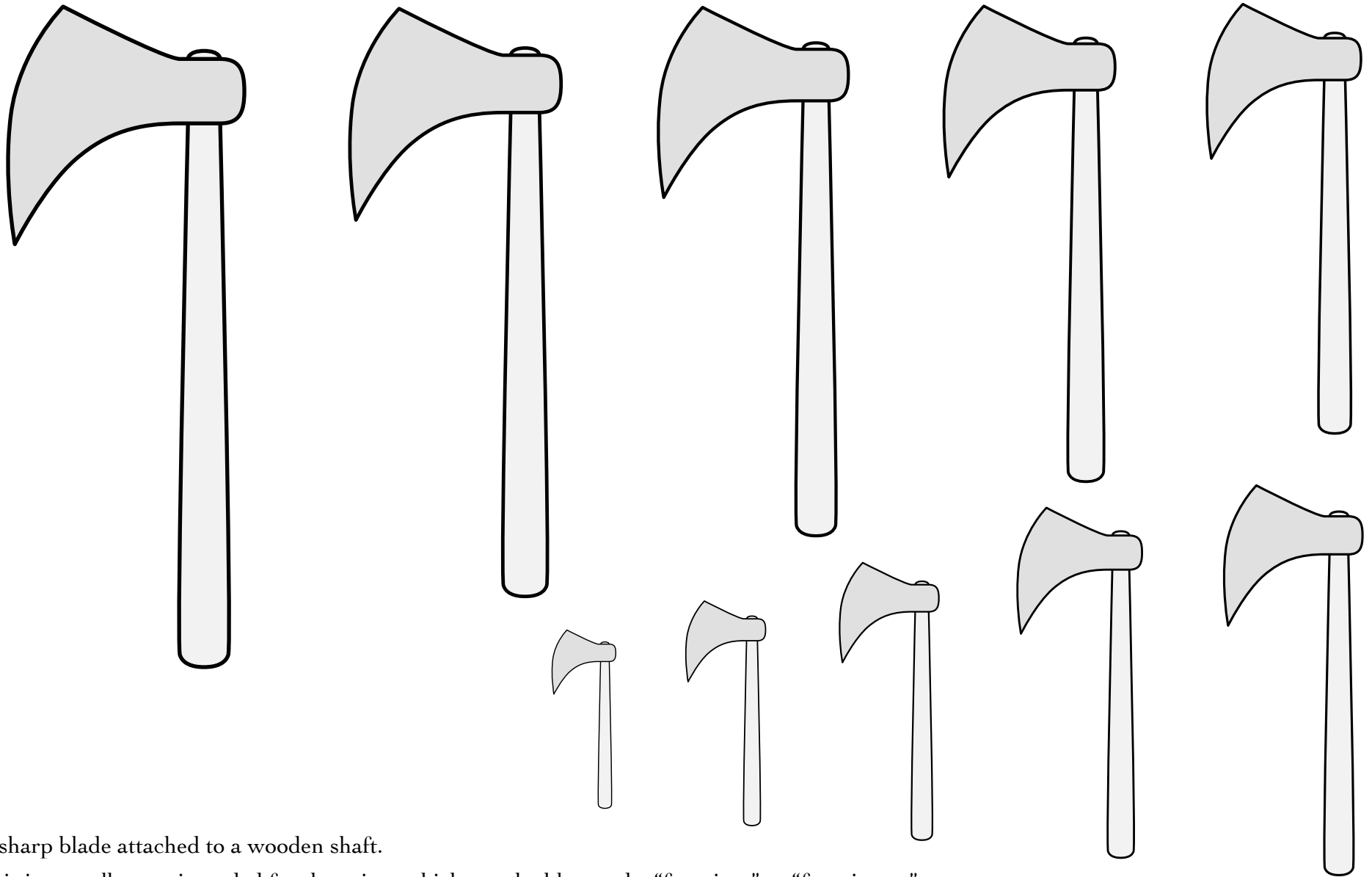

A sharp blade attached to a wooden shaft.

This is a smaller axe intended for throwing, which may be blazoned a “francisca” or “francisque.”

Default orientation: handle to base, blade to dexter.

Source: Pennsic Traceable Art. Artist unknown.

Adapted by Mathghamhain Ua Ruadháin.

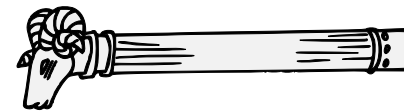
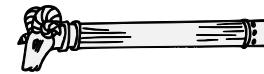
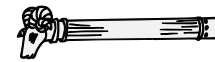
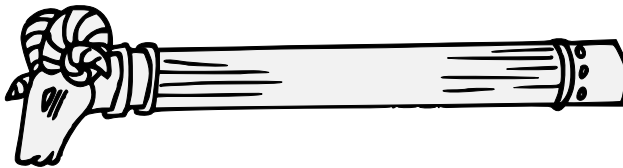
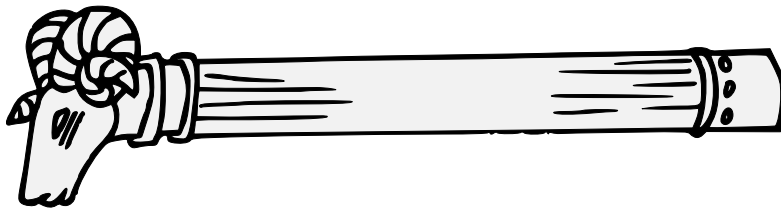
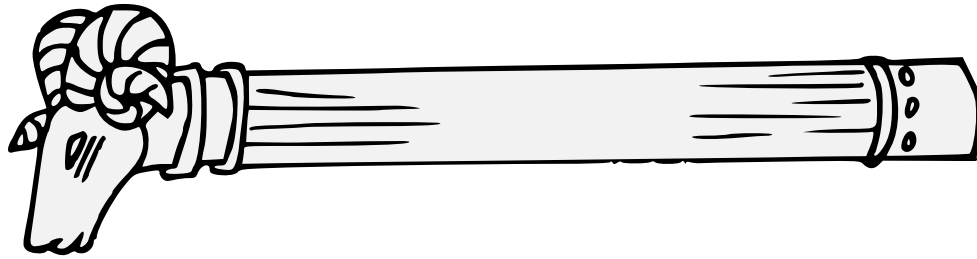

A tool for opening doors.

Default orientation: fesswise. No proper coloration.

Source: Pennsic Bored-Artist Collection. Artist: `Aziza al-Shiraziyya.

Battering Ram (1) 21.32

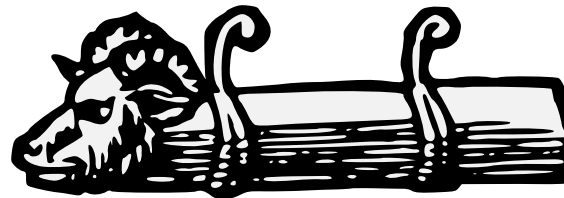
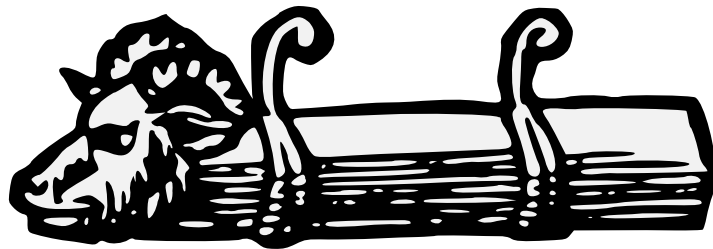
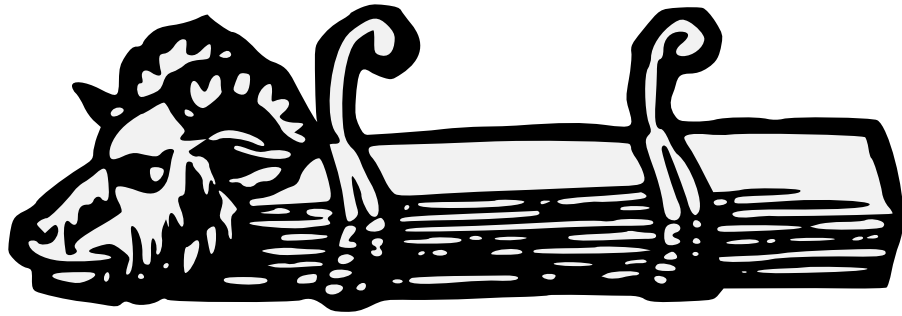

A tool for opening doors.

Default orientation: fesswise. No proper coloration.

Source: Guillim's Display of Heraldry. Artist unknown.

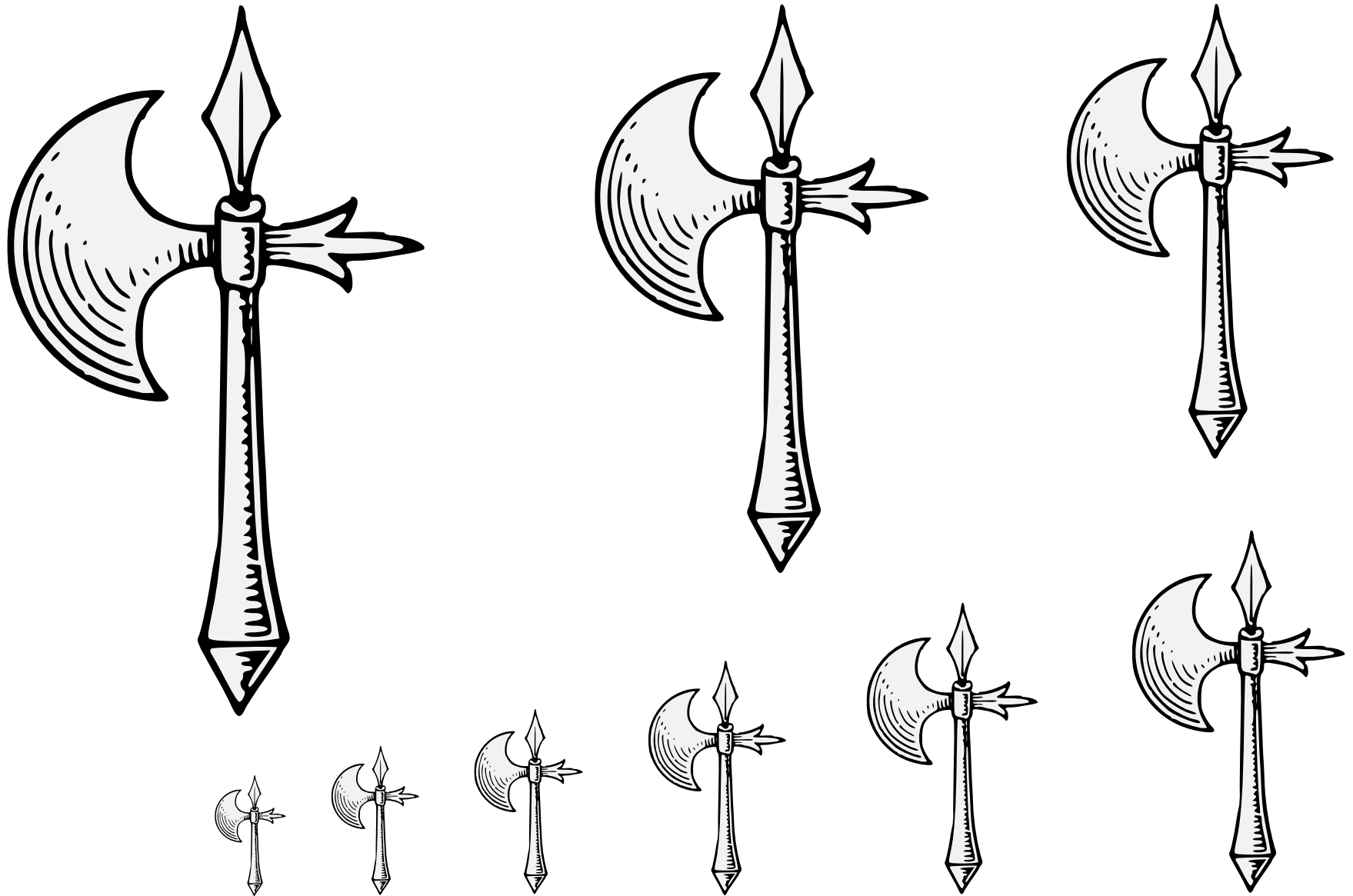

A sharp blade attached to a wooden shaft.

Default orientation: handle to base, blade to dexter.

Source: A Complete Guide to Heraldry. Artist: Graham Johnston.

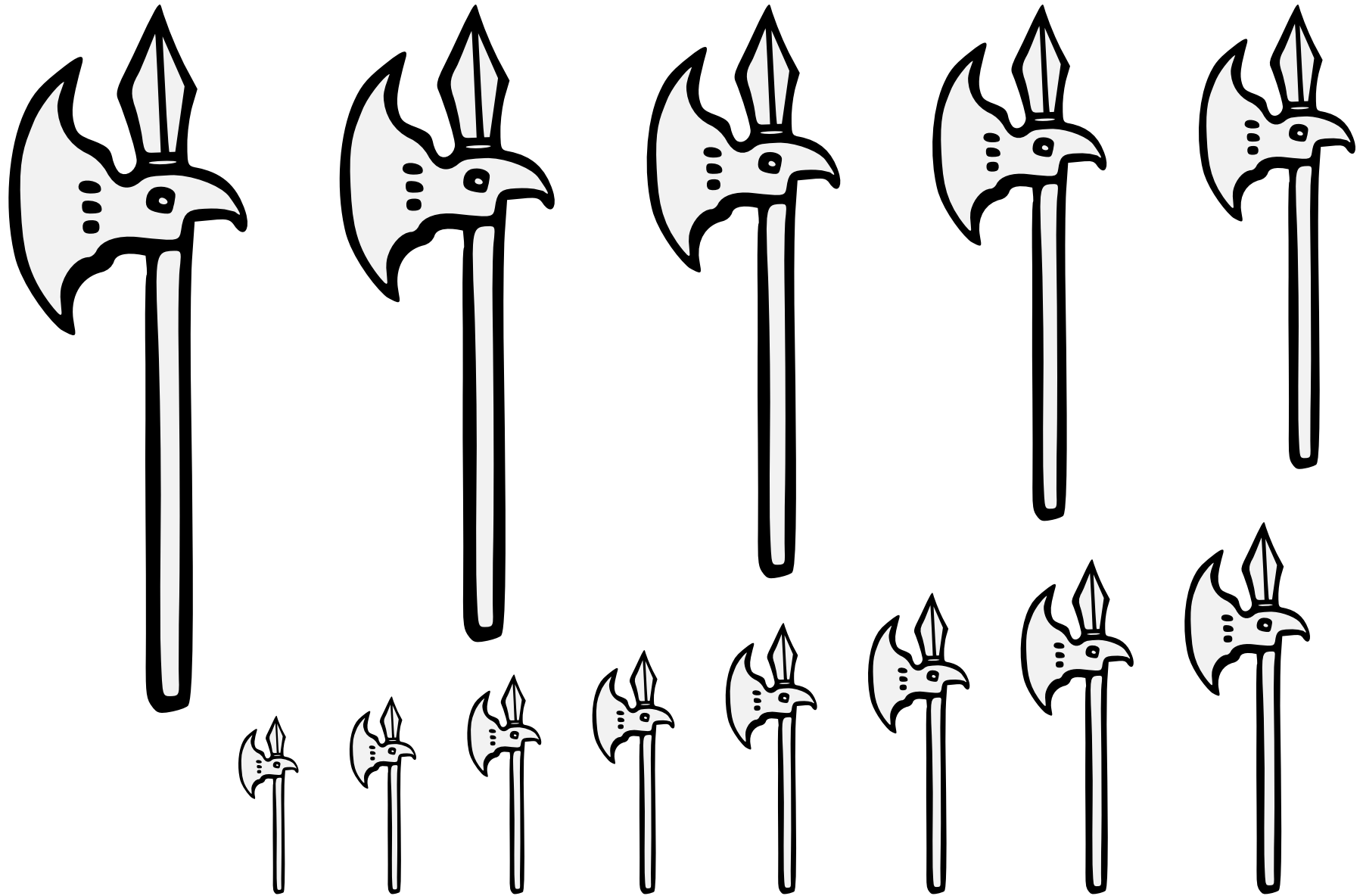

A sharp blade attached to a wooden shaft.  
Default orientation: handle to base, blade to dexter.  
Source: Workes of Armorie. Artist: John Bossewell.

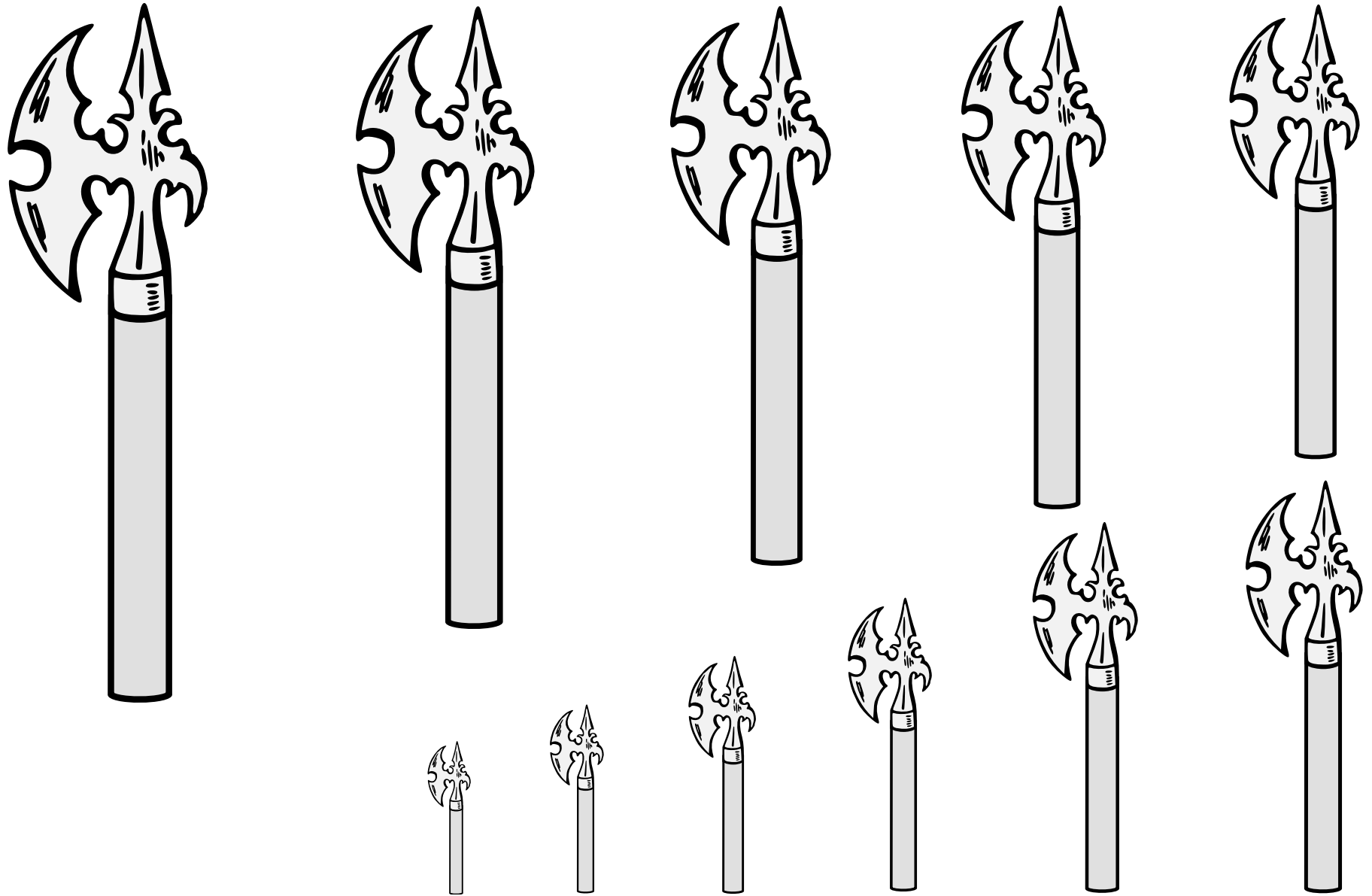

A sharp blade attached to a wooden shaft.

Default orientation: handle to base, blade to dexter.

Source: Vocabulaire-Atlas Héraldique. Artist unknown. (Illustration 492.)

**Battle-Axe (3)** 21.36



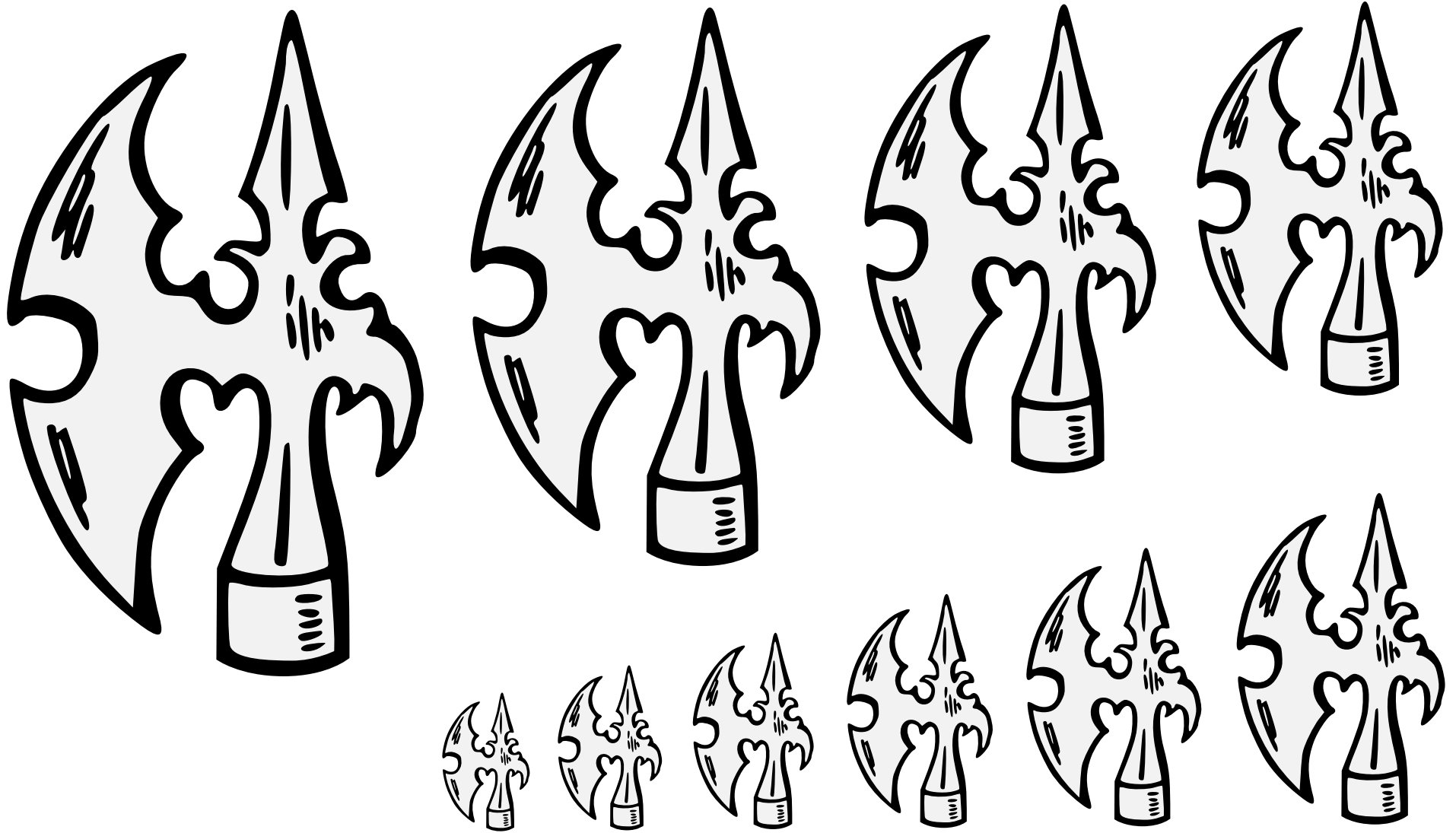

A sharp blade attached to a wooden shaft.

Default orientation: handle to base, blade to dexter.

Source: Vocabulaire-Atlas Héraldique. Artist unknown. (Illustration 492.)

Battle-Axe Head 21.37

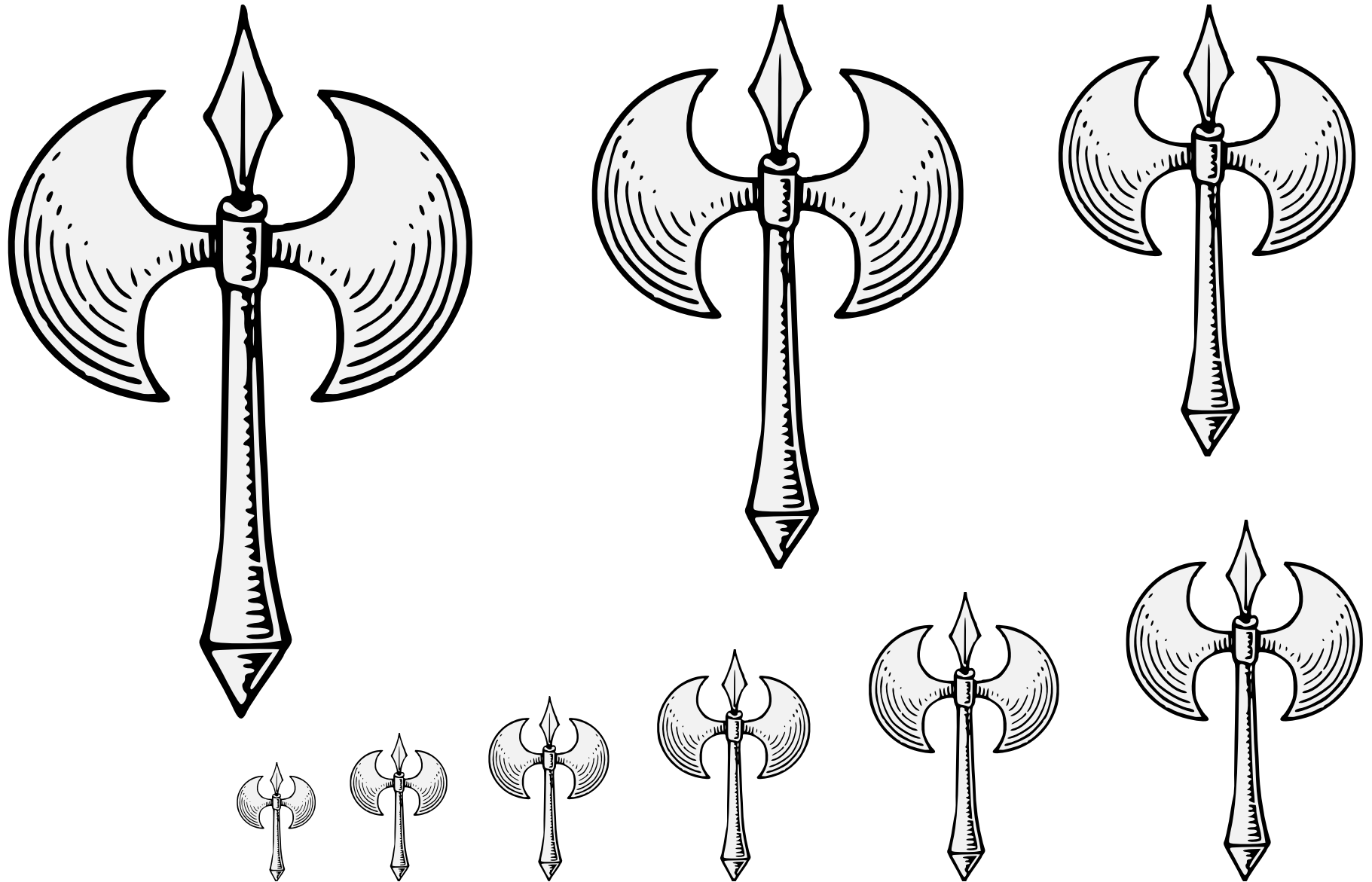

A sharp blade attached to a wooden shaft.

Default orientation: handle to base, blade to dexter.

Source: A Complete Guide to Heraldry. Artist: Graham Johnston. Adapted by Mathghamhain Ua Ruadháin.

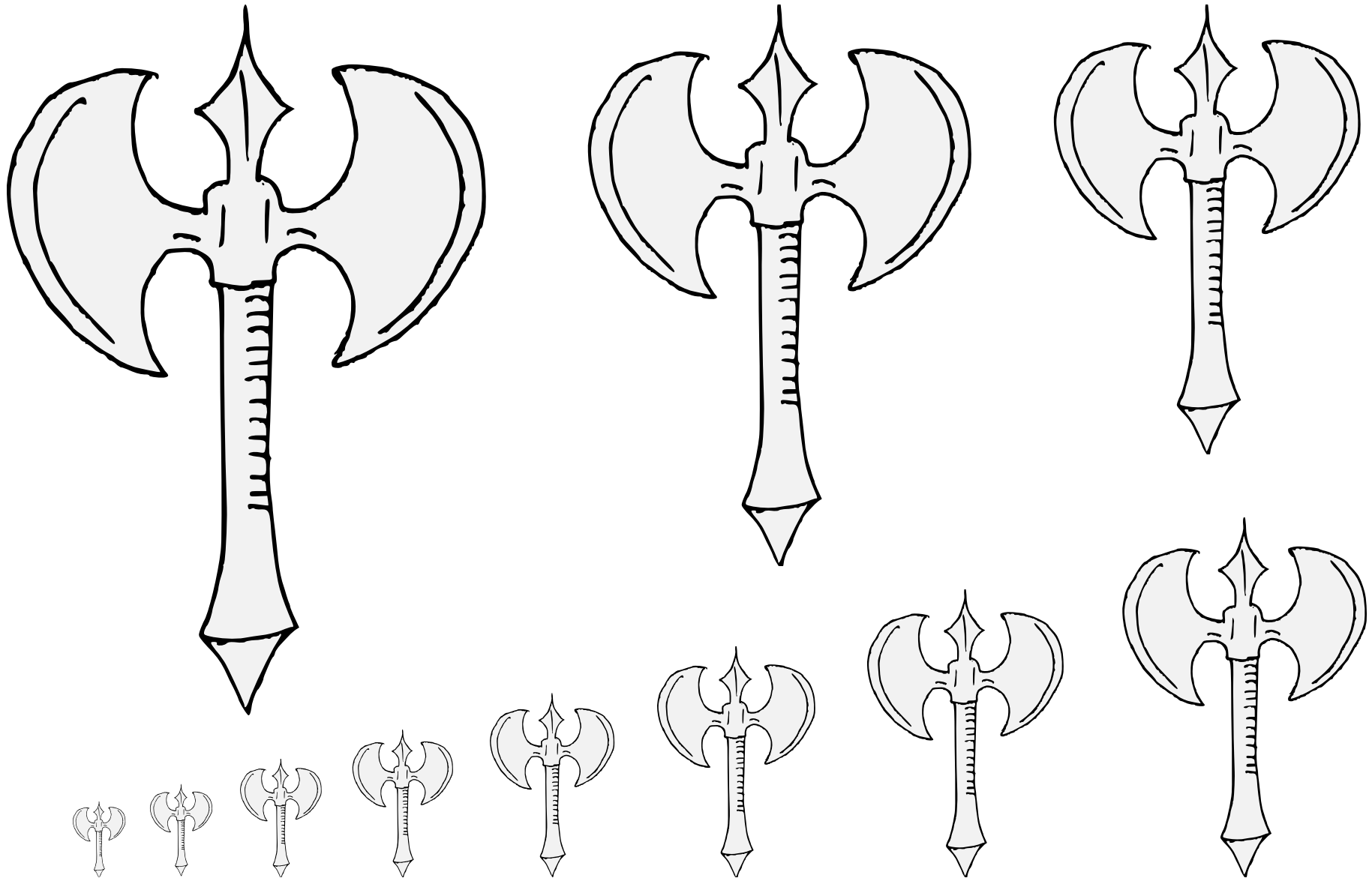

A sharp blade attached to a wooden shaft.  
Default orientation: handle to base, blade to dexter.  
Source: Pennsic Traceable Art. Artist unknown.

## Battle-Axe, Double-Sided (2) 21.39

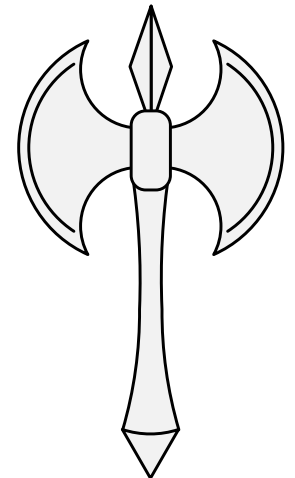
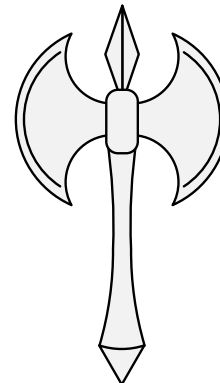
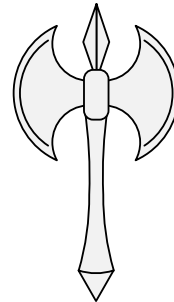
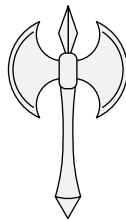
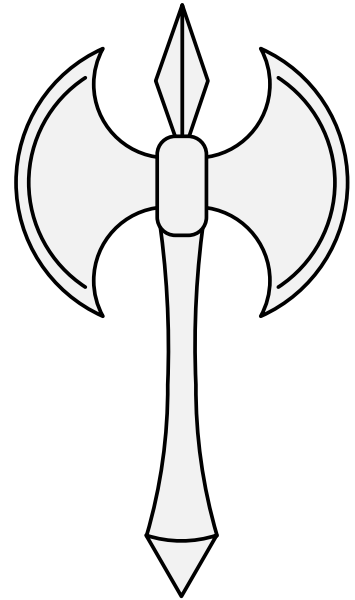
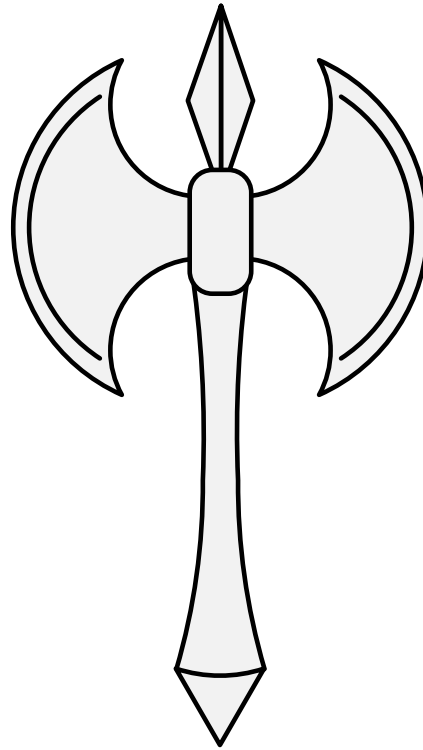
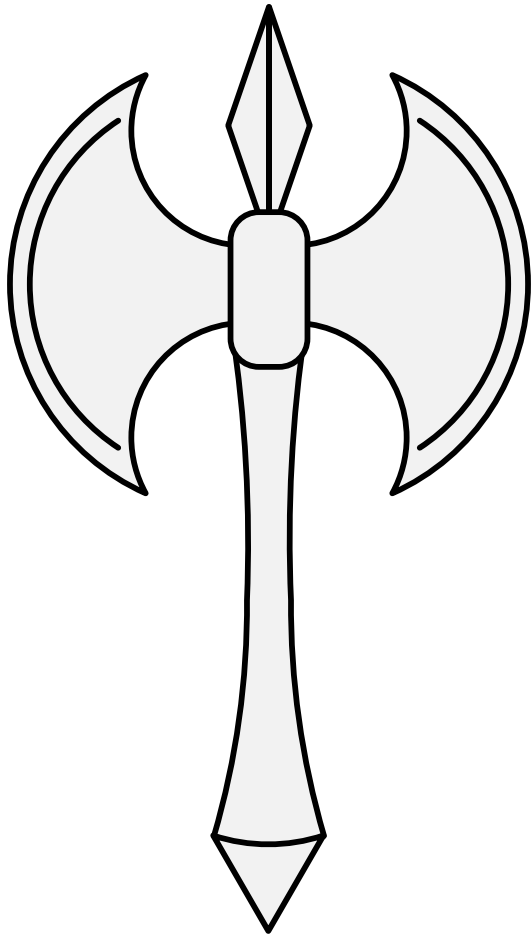

A sharp blade attached to a wooden shaft.

Default orientation: handle to base, blade to dexter.

Source: Viking Answer Lady SVG Images For Heraldry.

Artist: Gunnvôr silfrhárr.

**Battle-Axe, Double-Sided (3)** 21.40

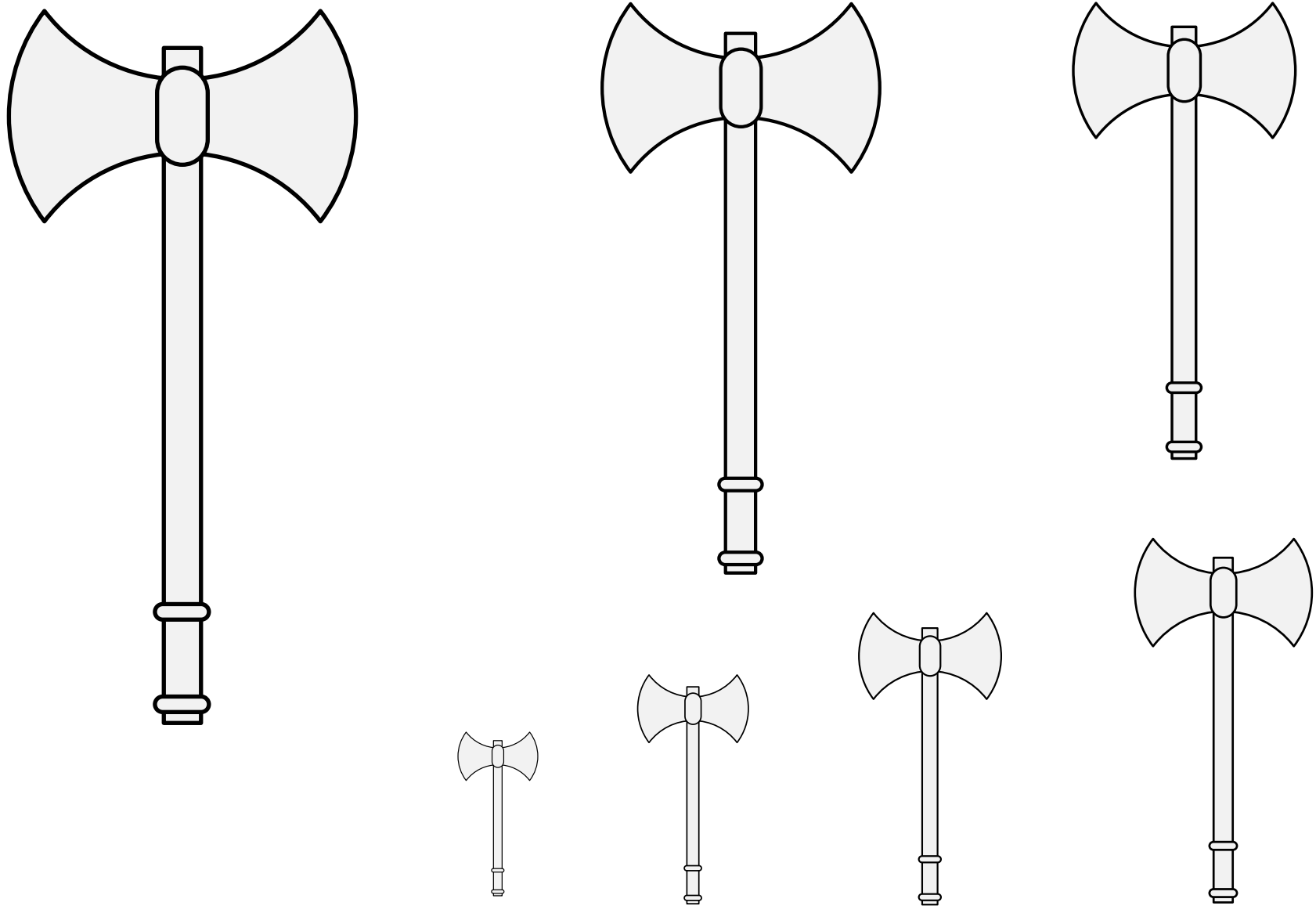

A sharp blade attached to a wooden shaft.

Default orientation: handle to base, blade to dexter.

Source: Viking Answer Lady SVG Images For Heraldry.

Artist: Gunnvôr silfrahárr.

**Battle-Axe, Double-Sided (4)** 🍷 21.41

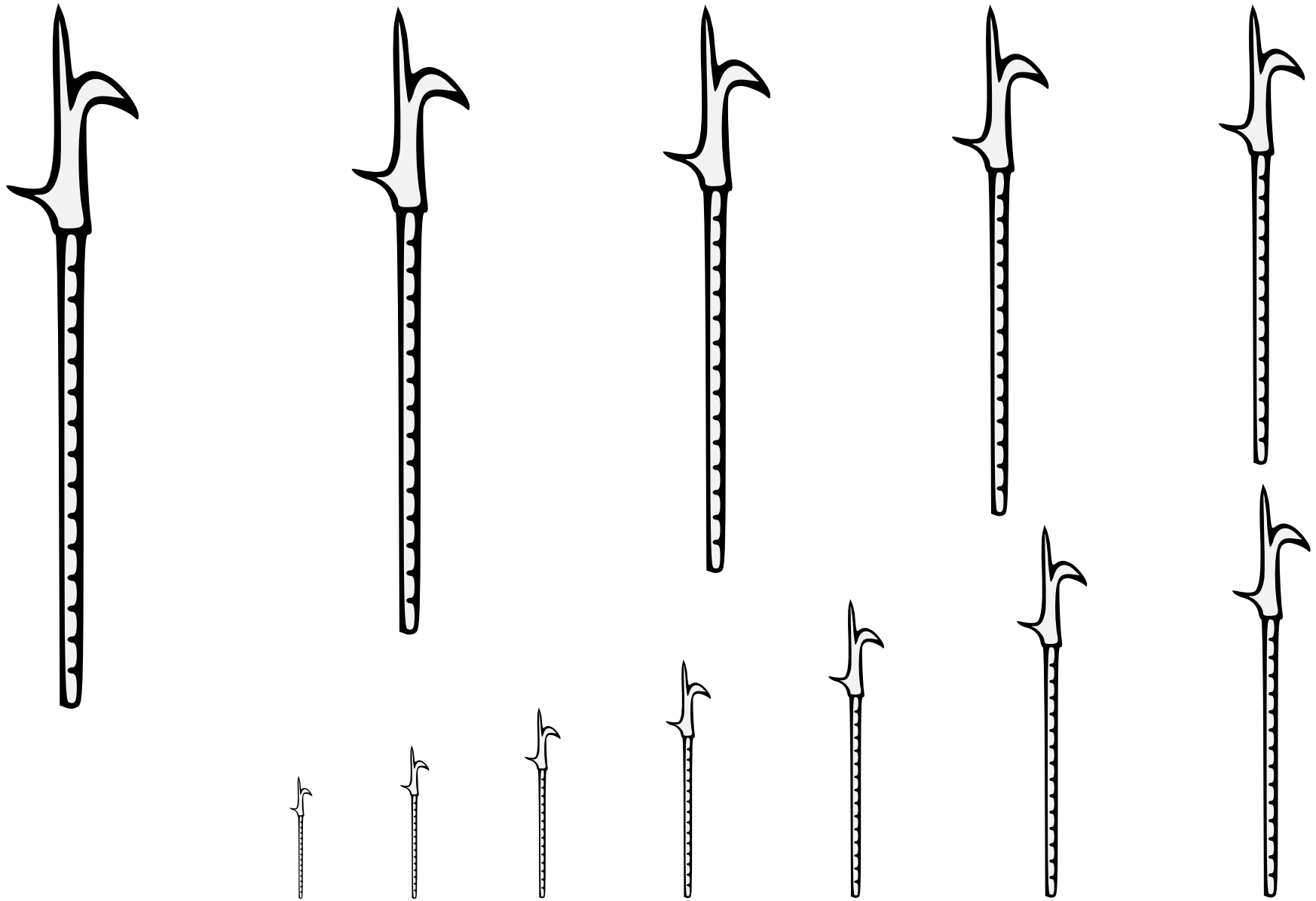

A sharp blade attached to a wooden shaft. Similar to a spear with sharp protruding hooks added.

Default orientation: point to chief. No proper coloration.

Source: Pennsic Traceable Art. Artist unknown.

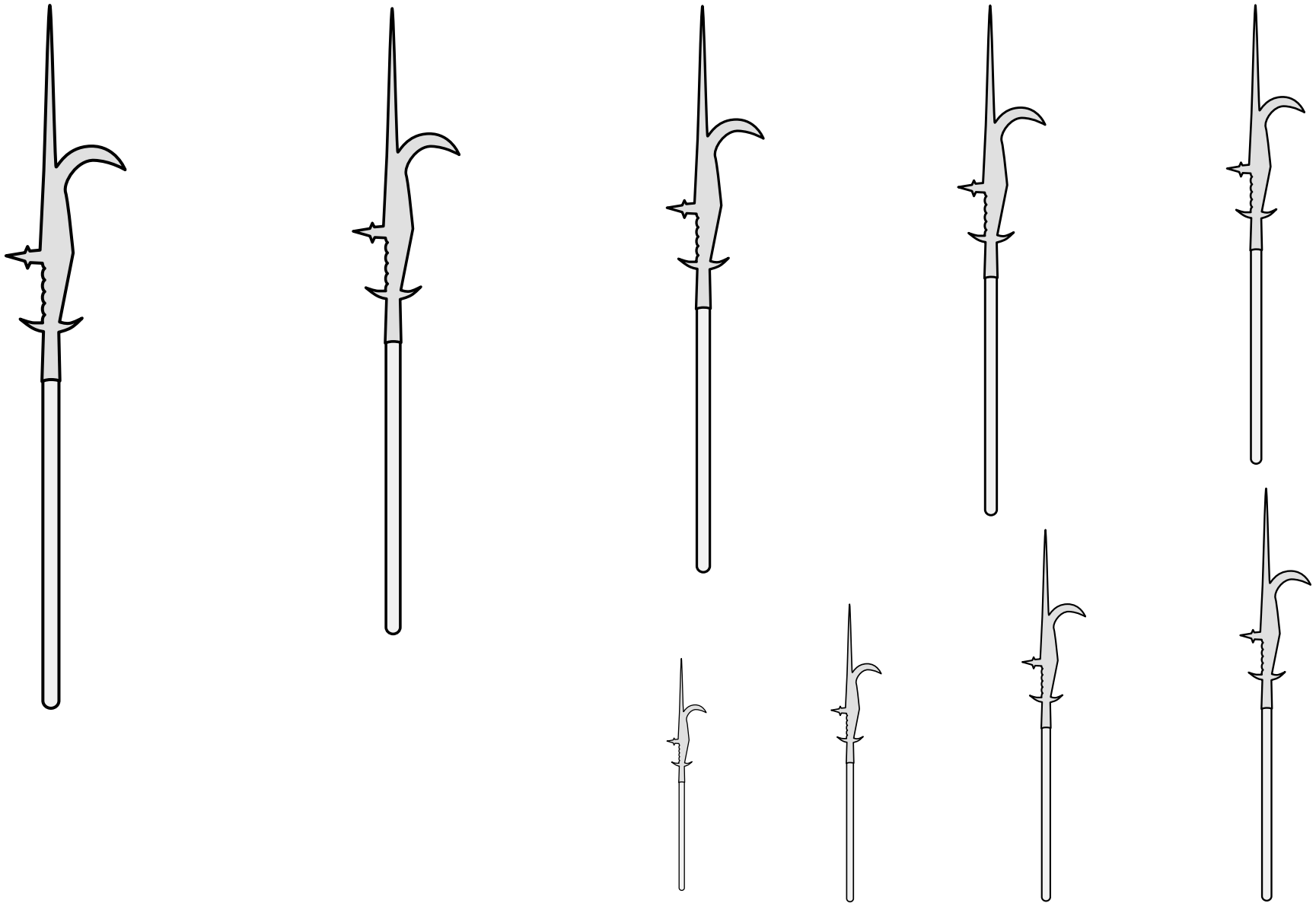

A sharp blade attached to a wooden shaft. Similar to a spear with sharp protruding hooks added.  
Default orientation: point to chief. No proper coloration.

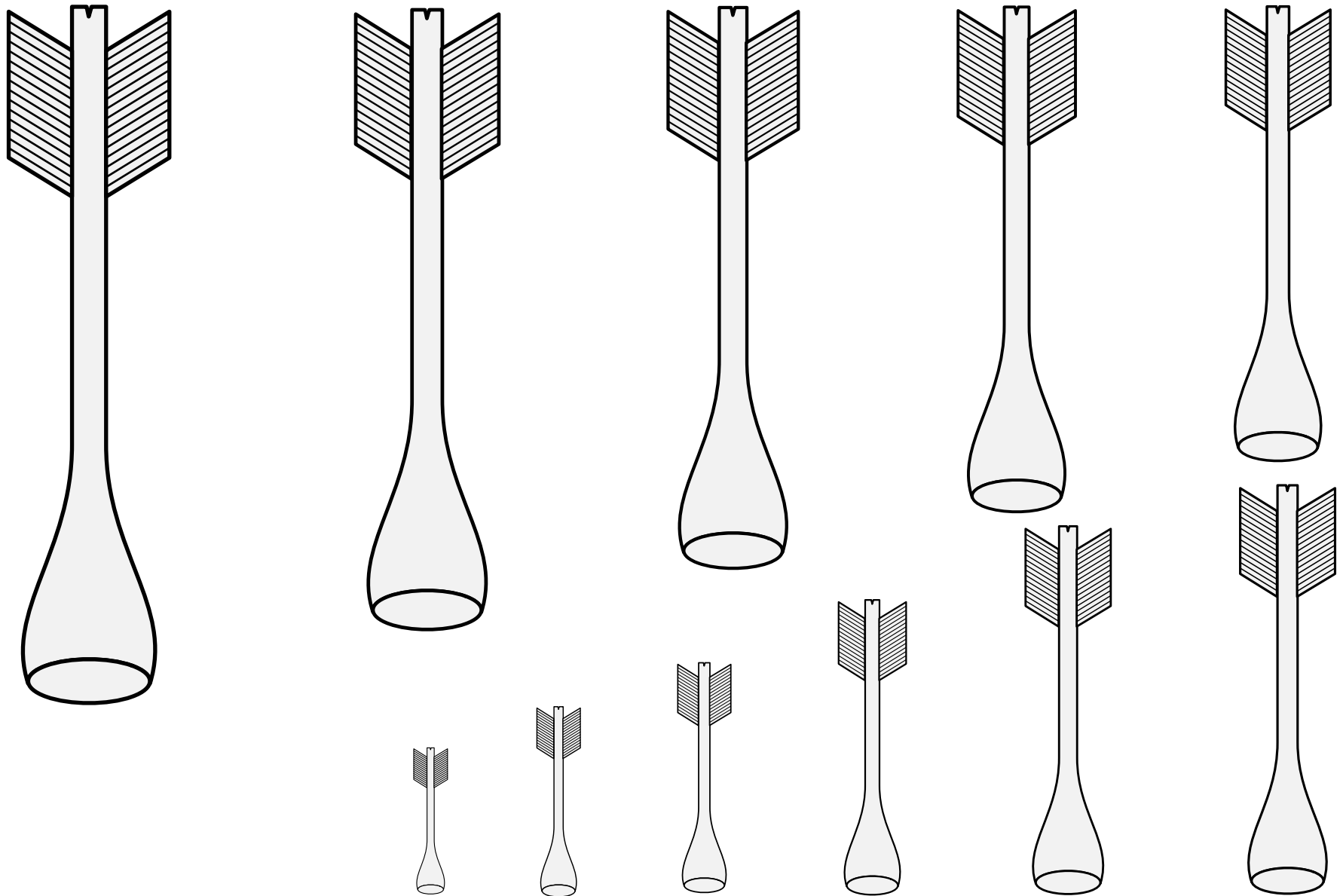

An arrow with a heavy rounded tip, use for hunting birds. May be blazoned a "boson" or "bird bolt."

Default orientation: point to base. No proper coloration.

Source: A Glossary of Terms Used in Heraldry. Artist: James or Irene Parker.



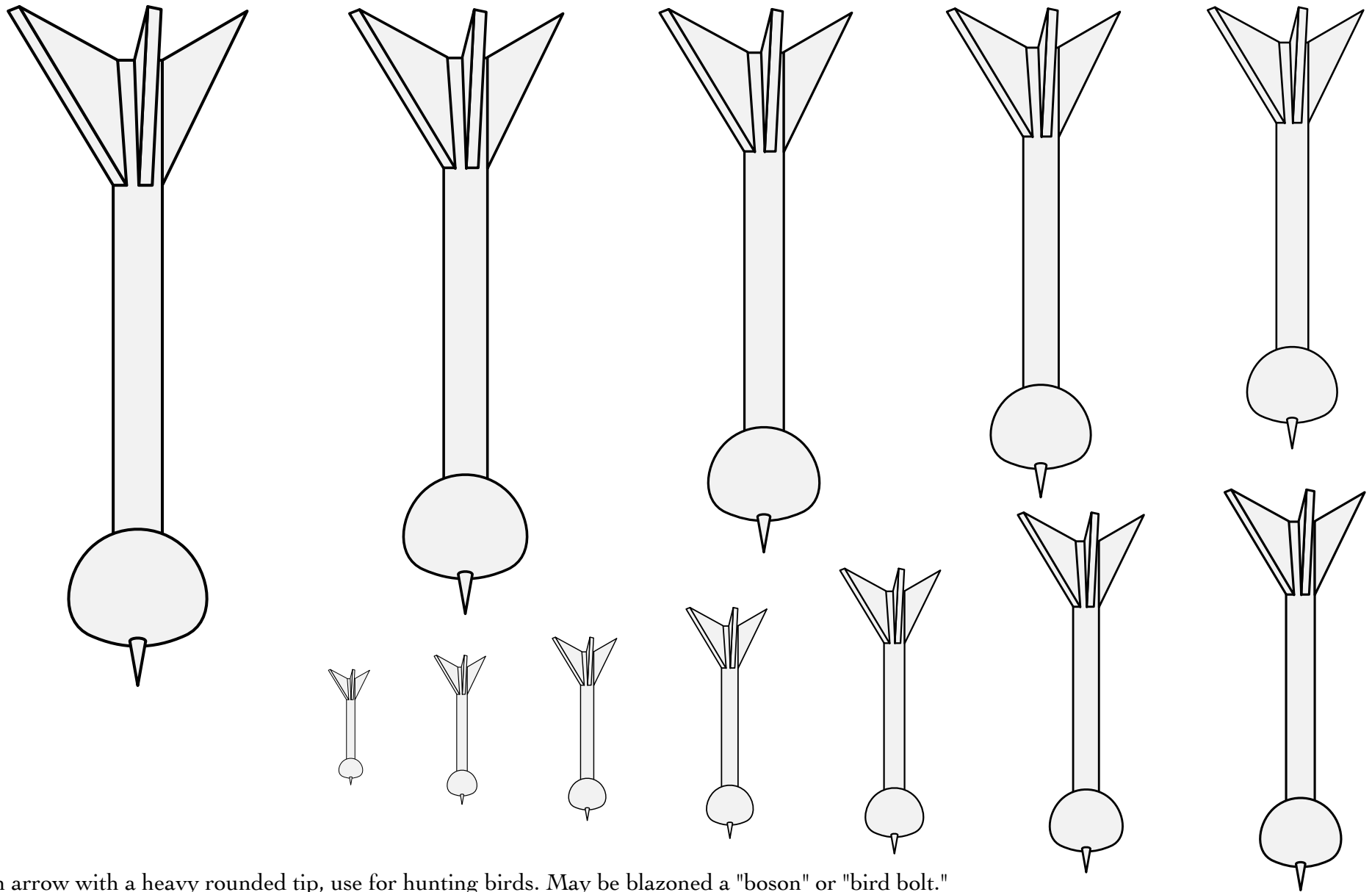

An arrow with a heavy rounded tip, use for hunting birds. May be blazoned a "boson" or "bird bolt."

Default orientation: point to base. No proper coloration.

This version was used in the arms of the Boson family.

Source: A Cyclopedia of Costume. Artist unknown. (Volume I, page 48.)

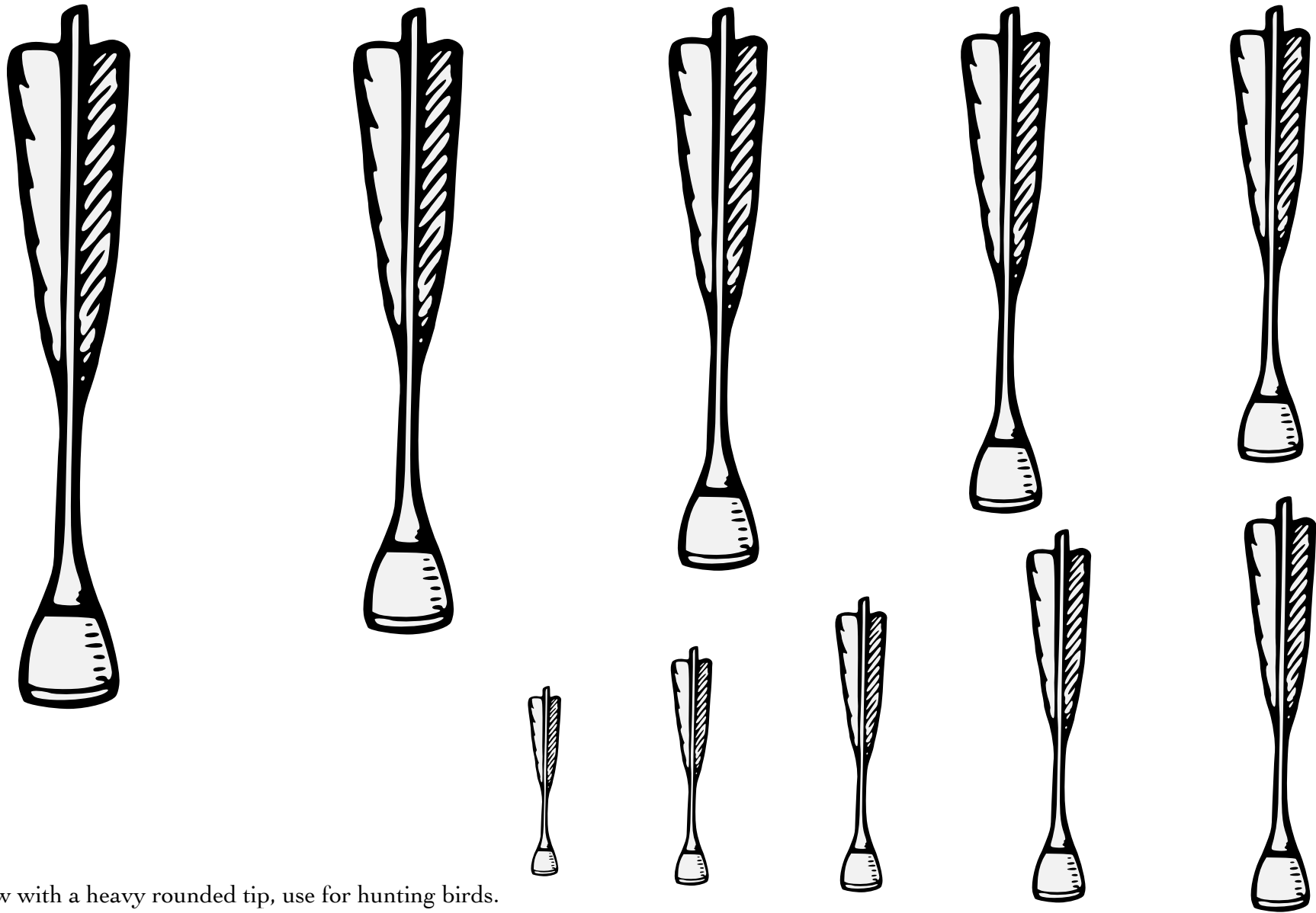

An arrow with a heavy rounded tip, use for hunting birds.  
May be blazoned a "boson" or "bird bolt."

Default orientation: point to base. No proper coloration.

Source: Schlesisches Wappenbuch.  
Artist unknown. (Page 144.)

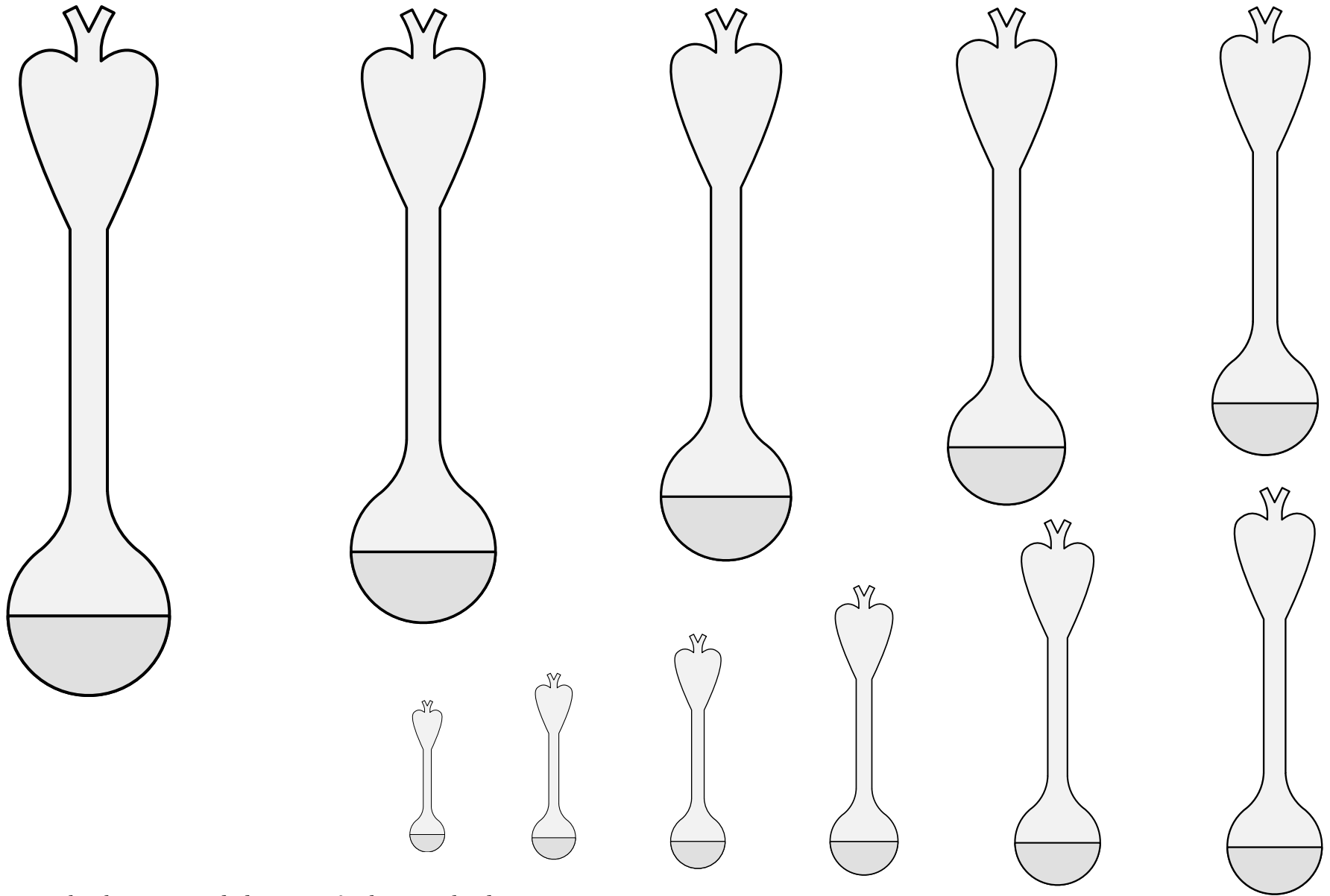

An arrow with a heavy rounded tip, use for hunting birds.  
May be blazoned a "boson" or "bird bolt."

Default orientation: point to base. No proper coloration.

Source: Powell Roll. Artist unknown. (Folio 12r, arms of Bosun.)

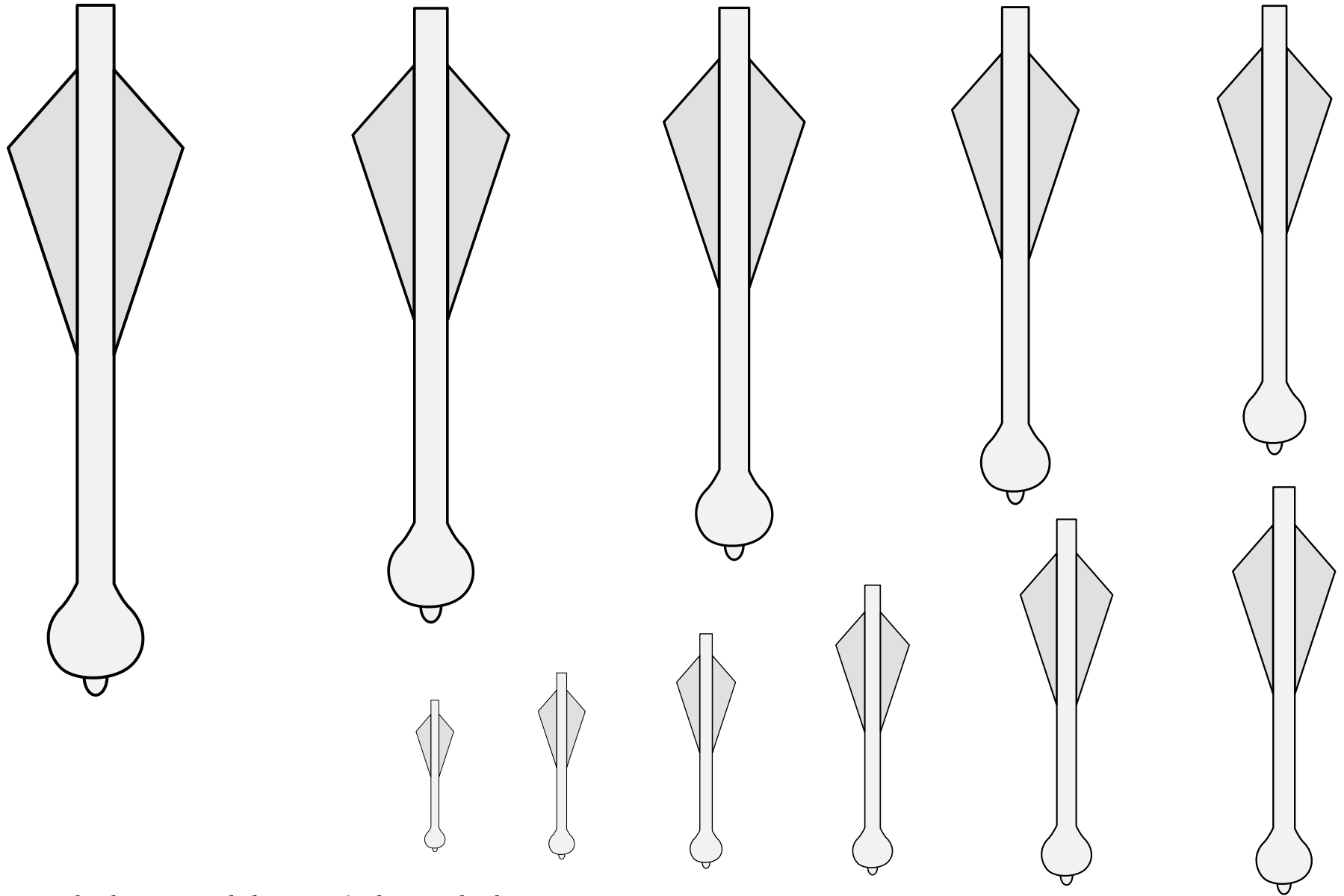

An arrow with a heavy rounded tip, use for hunting birds.  
May be blazoned a "boson" or "bird bolt."

Default orientation: point to base. No proper coloration.

Source: English Arms A. Artist unknown. (Page 49.)

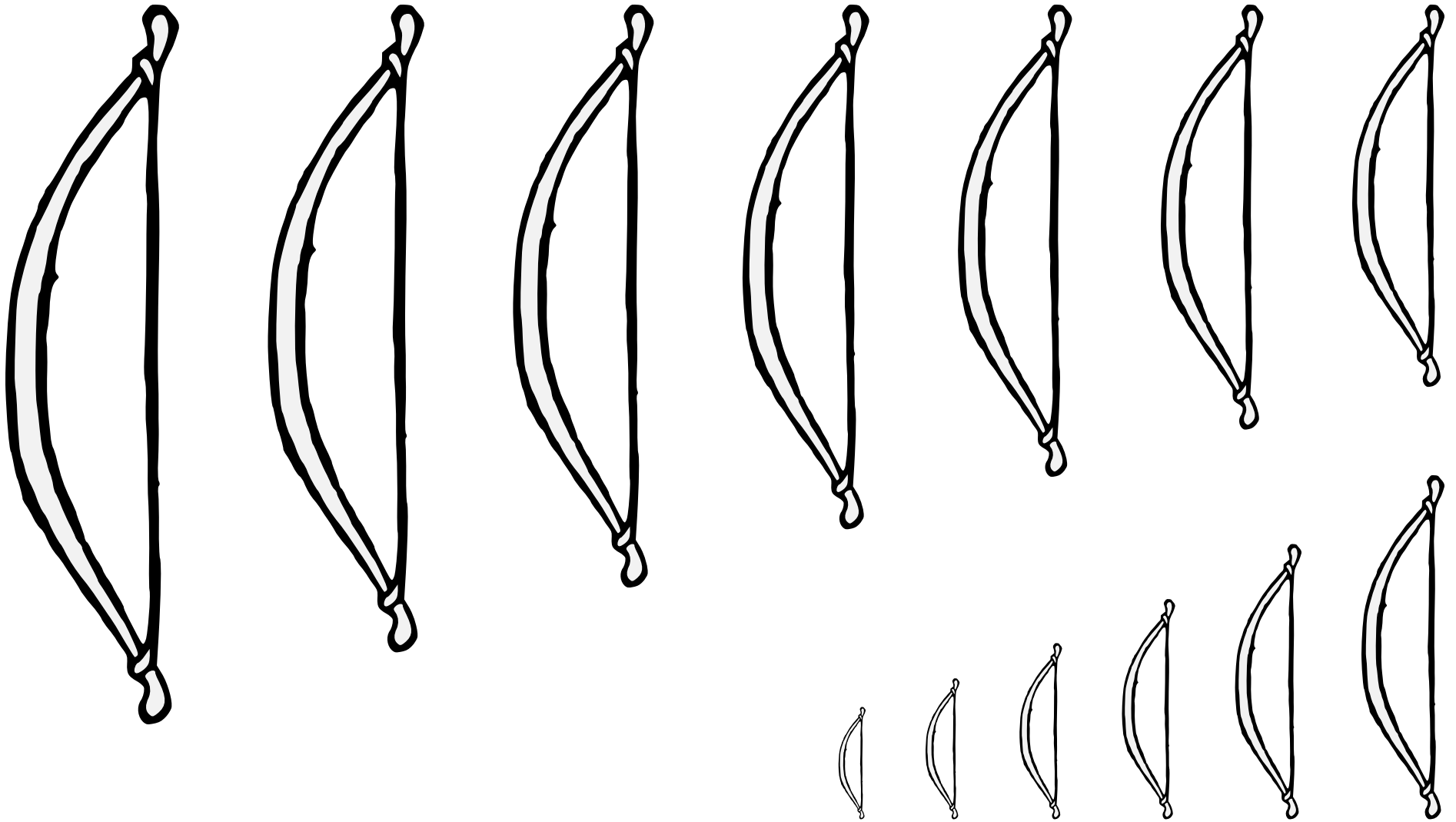

A tool for projecting arrows, typically made of wood or horn and string or sinew. May be blazoned a “longbow.”

Default orientation: palewise, shooting to dexter, or when fesswise, shooting to chief. No proper coloration.

Source: Guillim’s Display of Heraldry. Artist unknown.

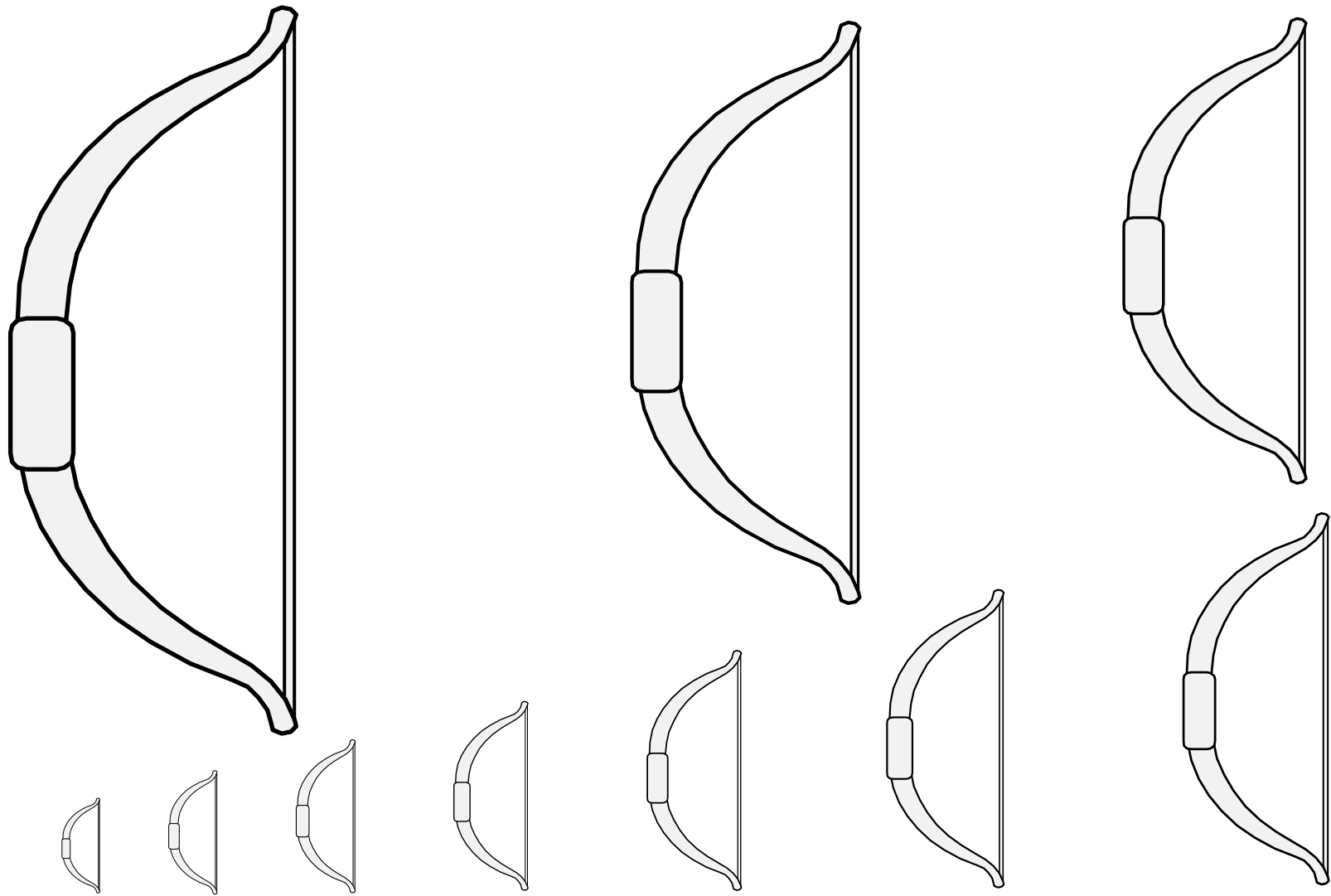

A tool for projecting arrows, typically made of wood or horn and string or sinew. May be blazoned a “longbow.”

Default orientation: palewise, shooting to dexter, or when fesswise, shooting to chief. No proper coloration.

Source: Viking Answer Lady SVG Images For Heraldry. Artist: Gunnvôr silfráhr.

**Bow (2)** • 21.50

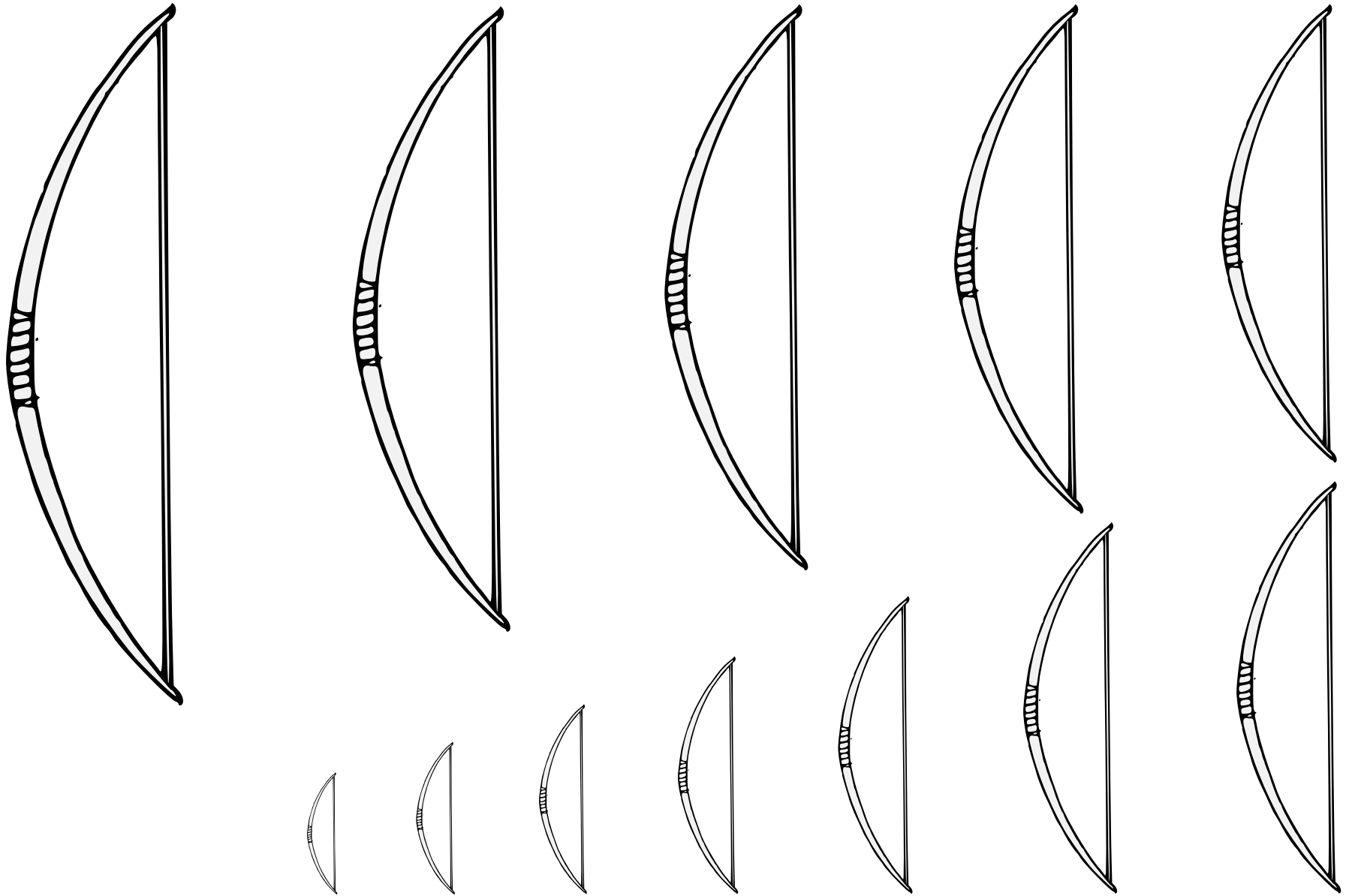

A tool for projecting arrows, typically made of wood or horn and string or sinew. May be blazoned a “longbow.”

Default orientation: palewise, shooting to dexter, or when fesswise, shooting to chief. No proper coloration.

Source: Pennsic Traceable Art. Artist: Roana d’Evreux.

**Bow (3)** 21.51

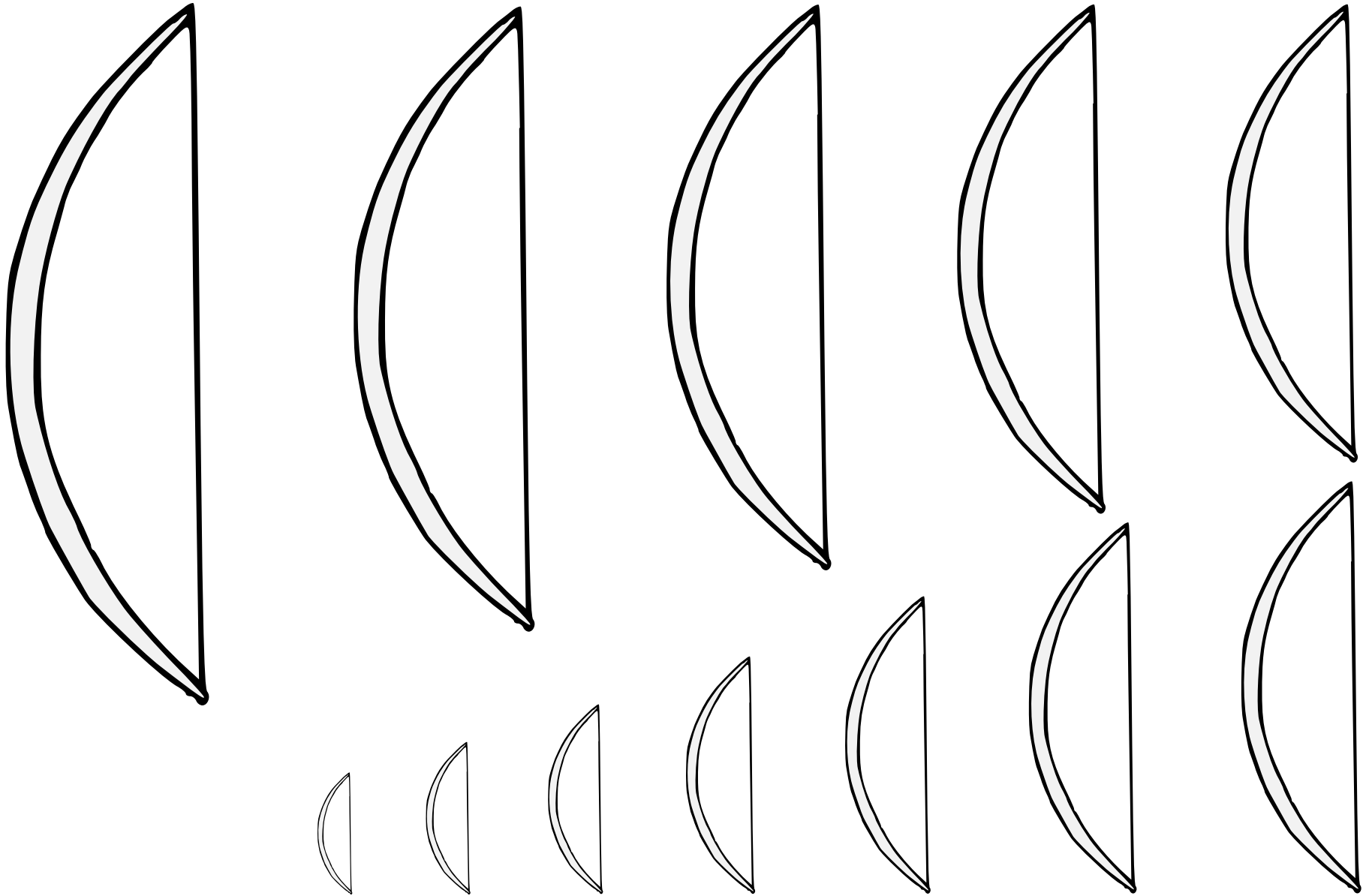

A tool for projecting arrows, typically made of wood or horn and string or sinew. May be blazoned a “longbow.”

Default orientation: palewise, shooting to dexter, or when fesswise, shooting to chief. No proper coloration.

Source: Pennsic Traceable Art. Artist: Roana d’Evreux.

**Bow (4)** • 21.52



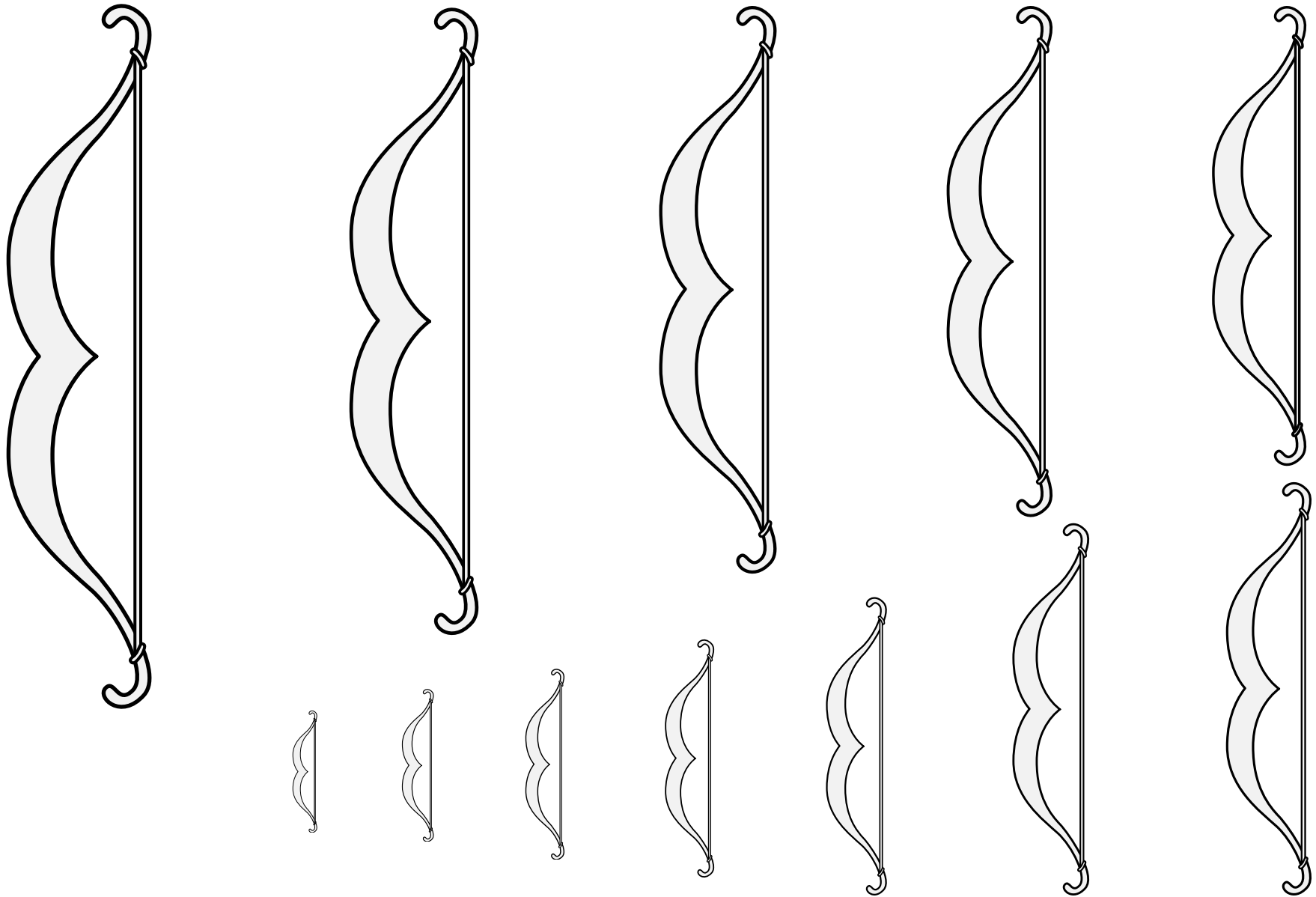

A tool for projecting arrows, typically made of wood or horn and string or sinew.

Default orientation: palewise, shooting to dexter, or when fesswise, shooting to chief. No proper coloration.

Source: Insignia Urbium Italiae Septentrionalis. Artist: Unknown. (Found in the arms of de Archix.)

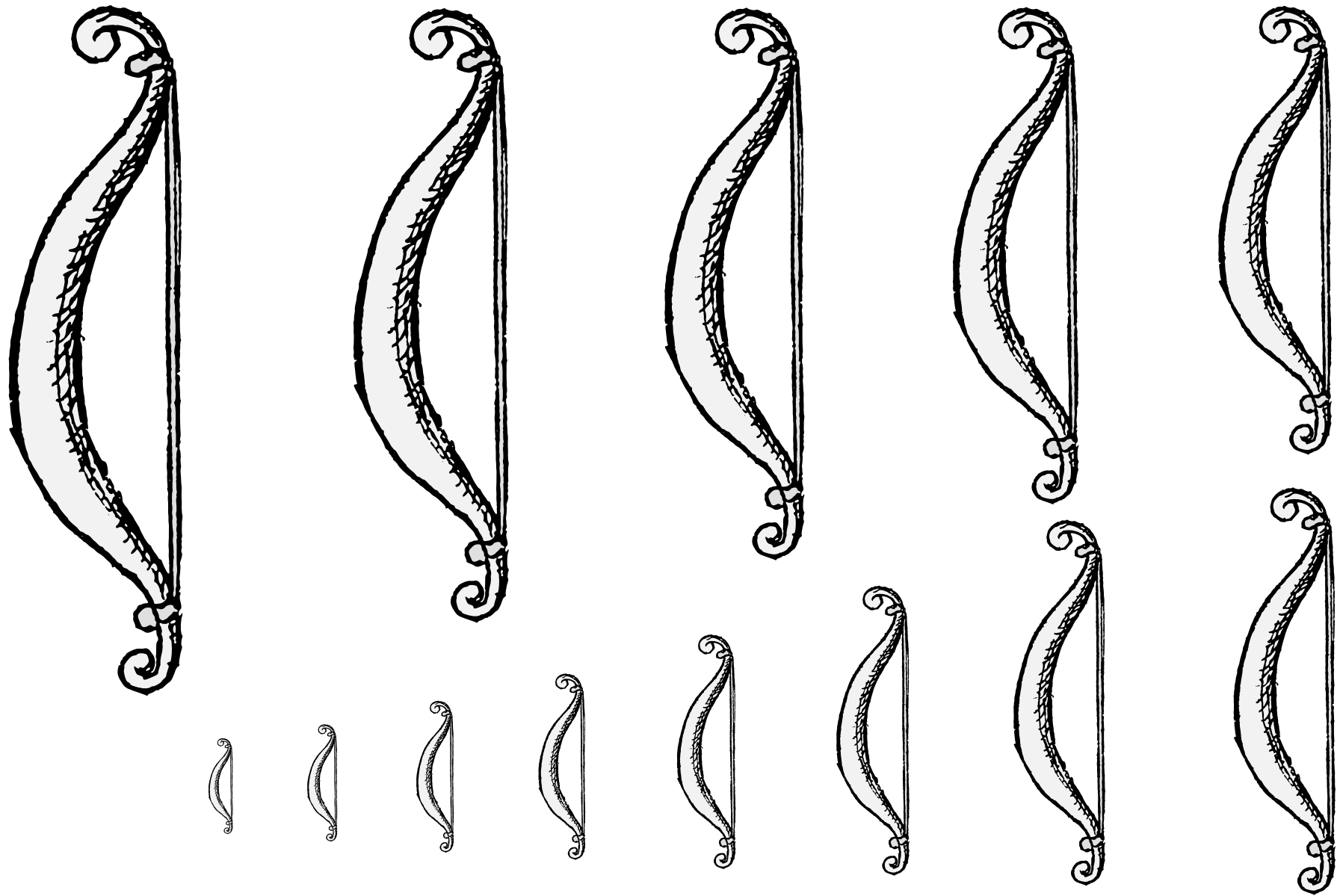

A tool for projecting arrows, typically made of wood or horn and string or sinew.

Default orientation: palewise, shooting to dexter, or when fesswise, shooting to chief. No proper coloration.

Source: Von Den Fürsten Grauen, Herren. Adapted by Iago ab Adam.

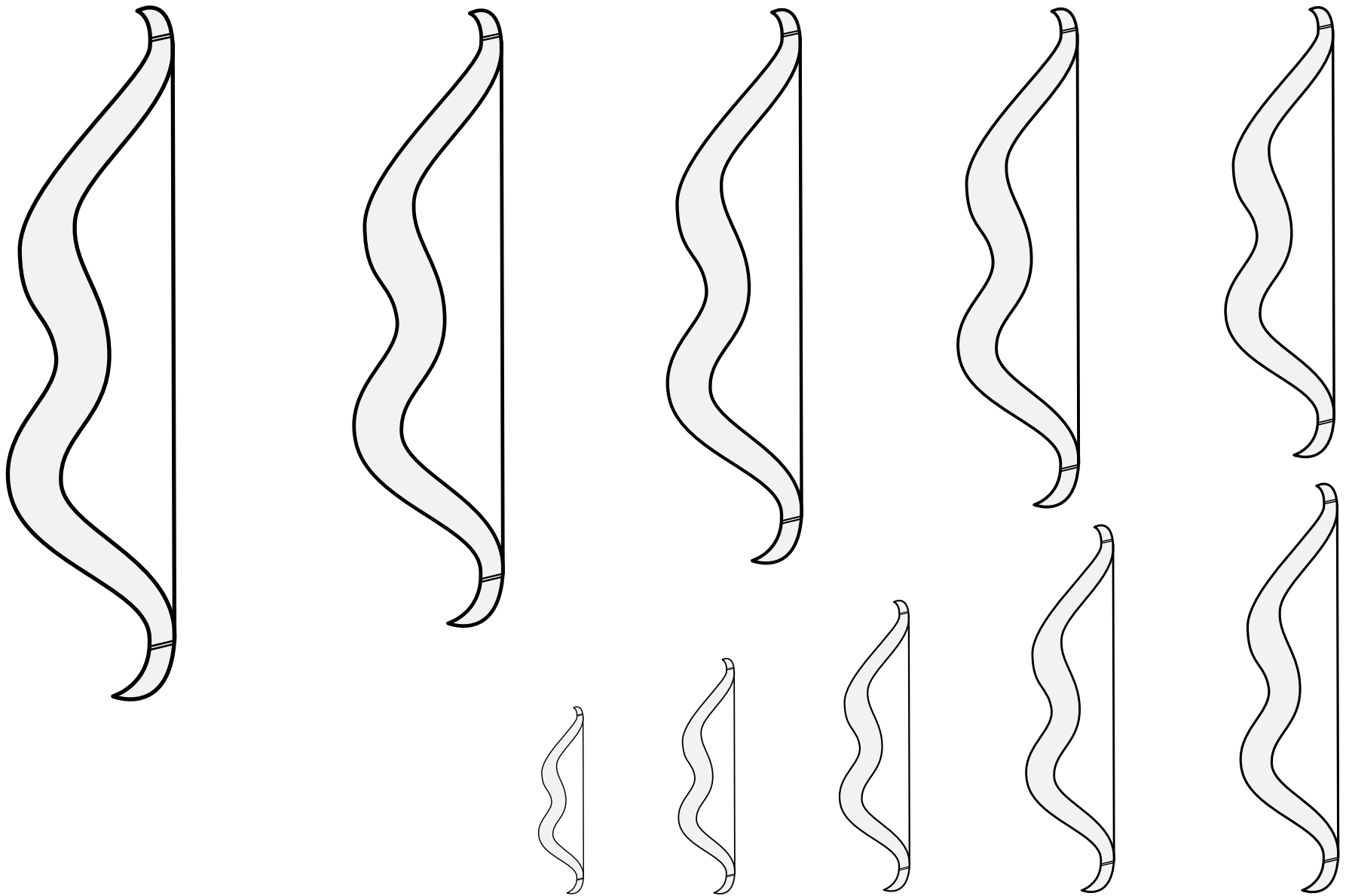

A tool for projecting arrows, typically made of wood or horn and string or sinew.

Default orientation: palewise, shooting to dexter, or when fesswise, shooting to chief. No proper coloration.

Source: Wappenbuch der Arlberg-Bruderschaft. Artist: Vigil Raber. (Folio 447.)

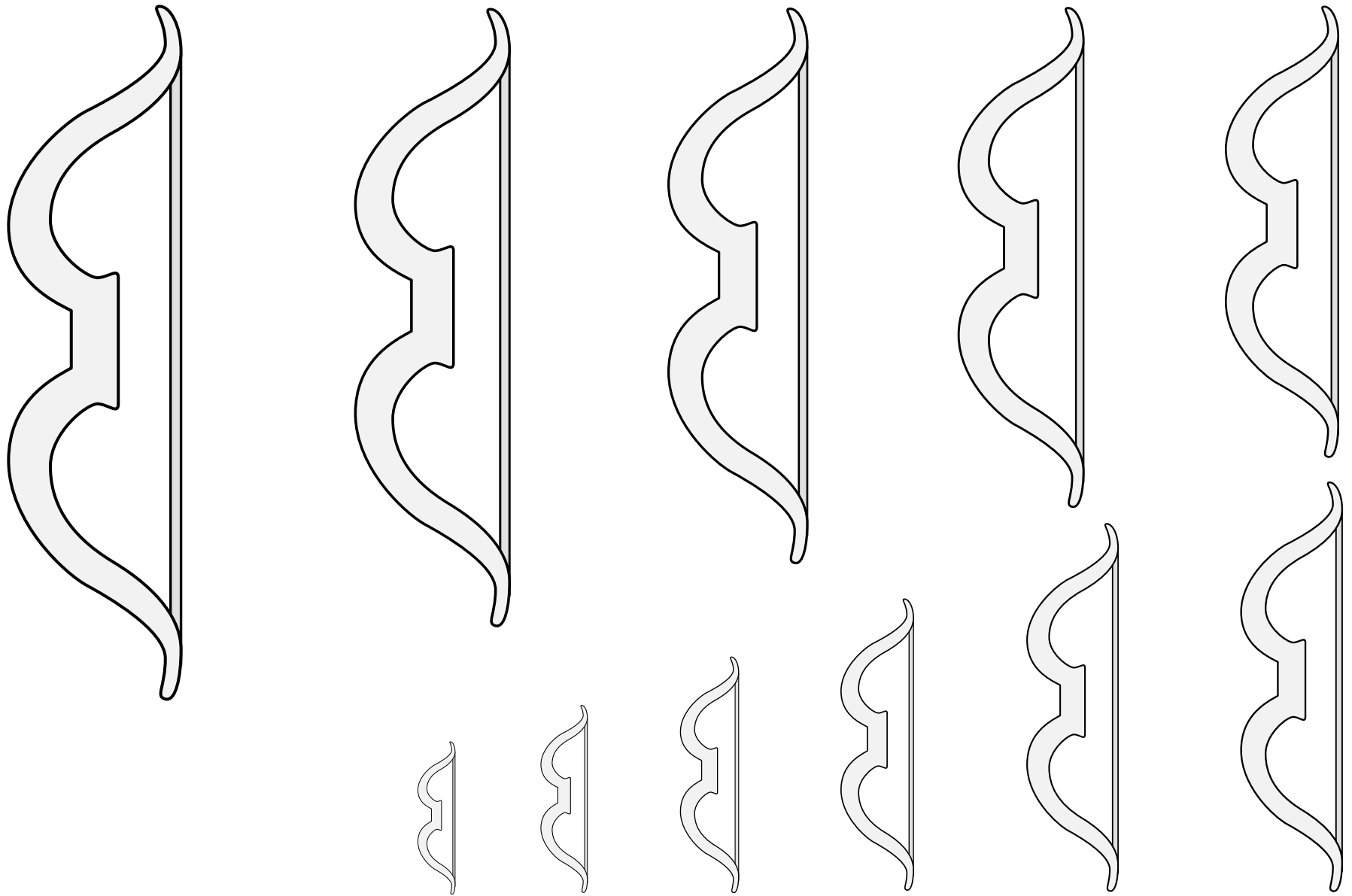

A tool for projecting arrows, typically made of wood or horn and string or sinew.

Default orientation: palewise, shooting to dexter, or when fesswise, shooting to chief. No proper coloration.

Source: Wapenboek van Gent. Artist: Vander Schelden. (Volume 1, page 54.)

**Bow (8)** • 21.56

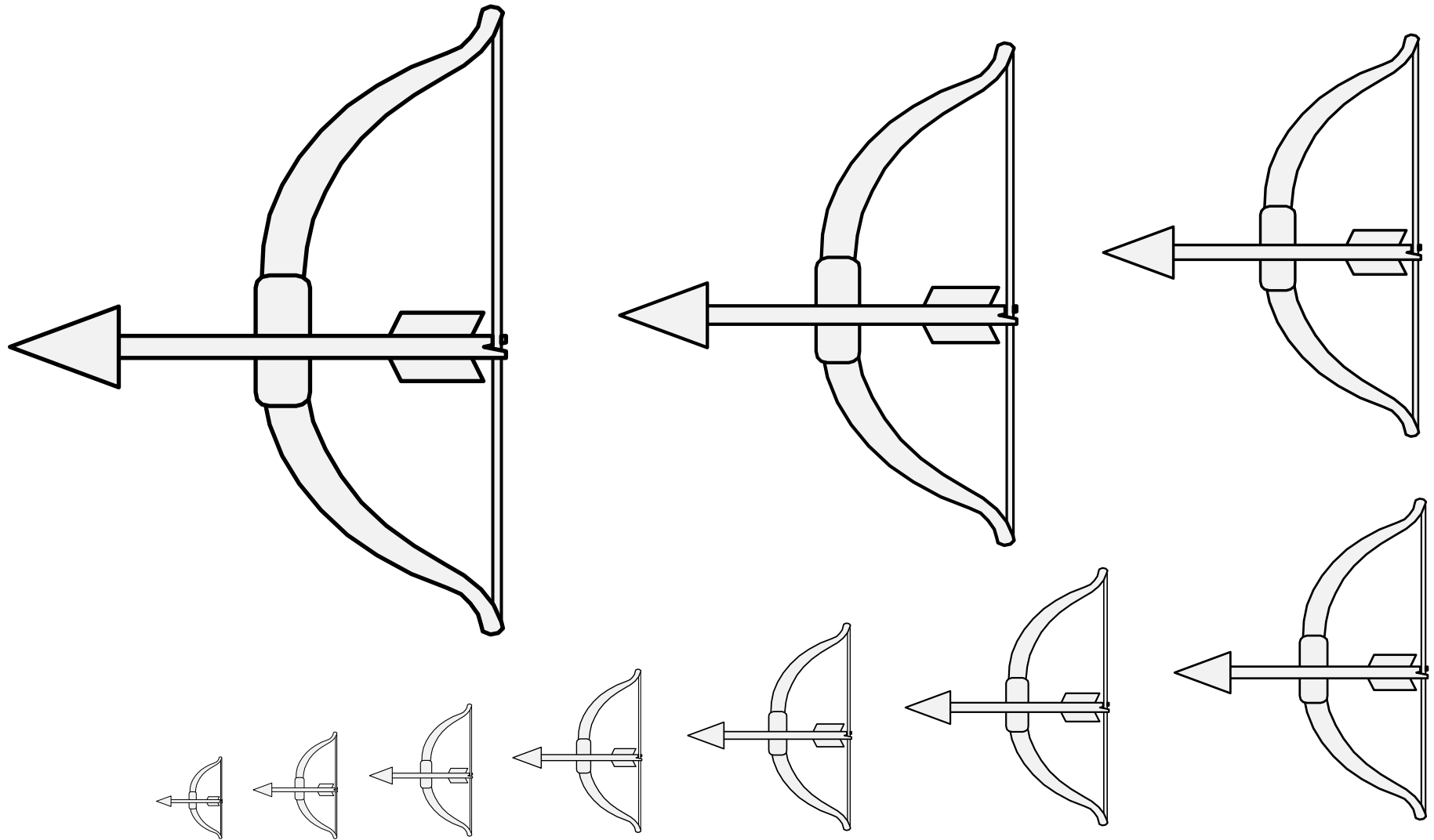

A tool for projecting arrows, typically made of wood or horn and string or sinew. May be blazoned a “longbow.”

Default orientation: palewise, shooting to dexter, or when fesswise, shooting to chief. No proper coloration.

Source: Viking Answer Lady SVG Images  
For Heraldry. Artist: Gunnvôr silfrahárr.

**Bow With An Arrow Nocked**    21.57

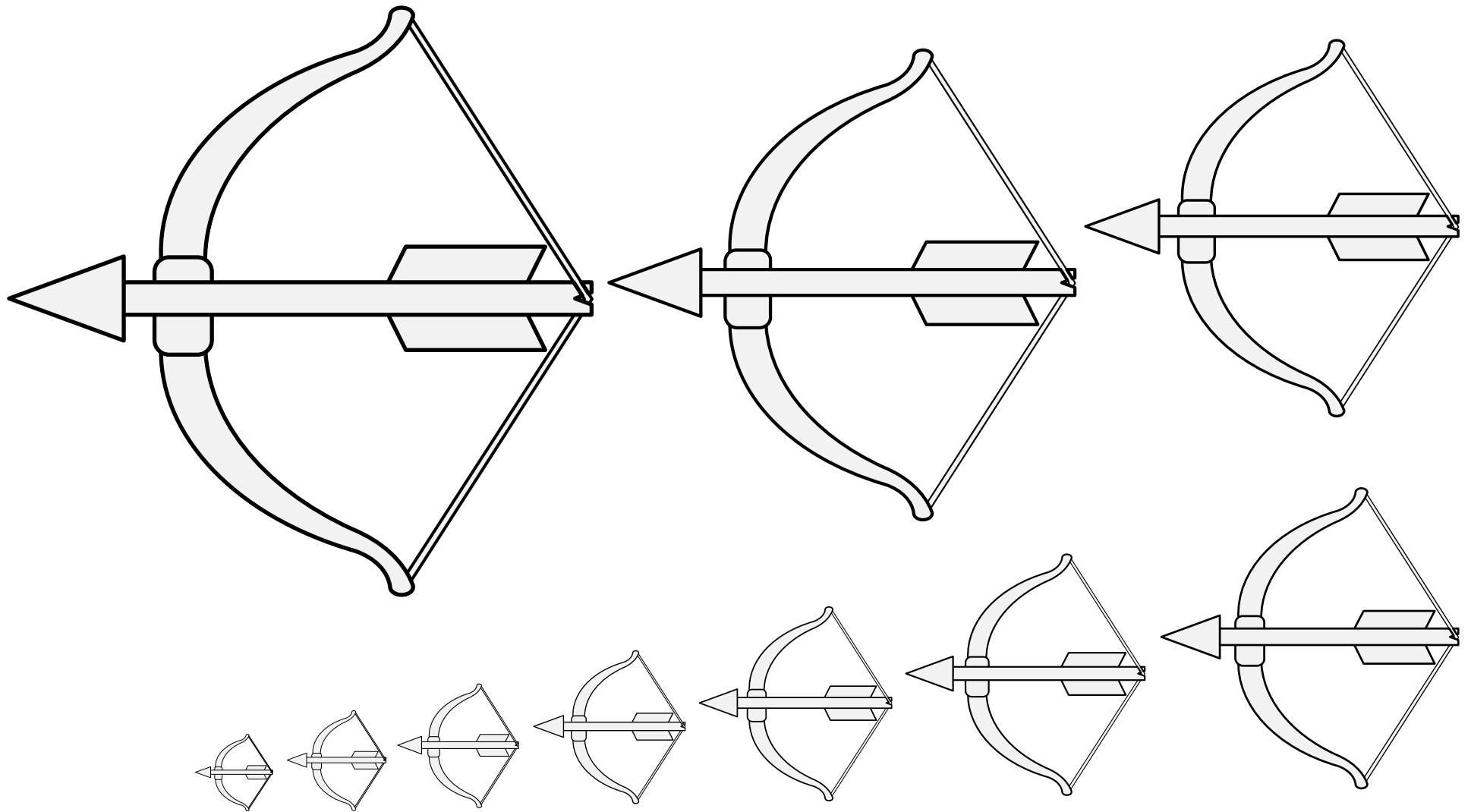

A tool for projecting arrows, typically made of wood or horn and string or sinew. May be blazoned a “longbow.”

Default orientation: palewise, shooting to dexter, or when fesswise, shooting to chief. No proper coloration.

Source: Viking Answer Lady SVG Images  
For Heraldry. Artist: Gunnvôr silfrahárr.

**Bow With An Arrow Nocked, Drawn • 21.58**

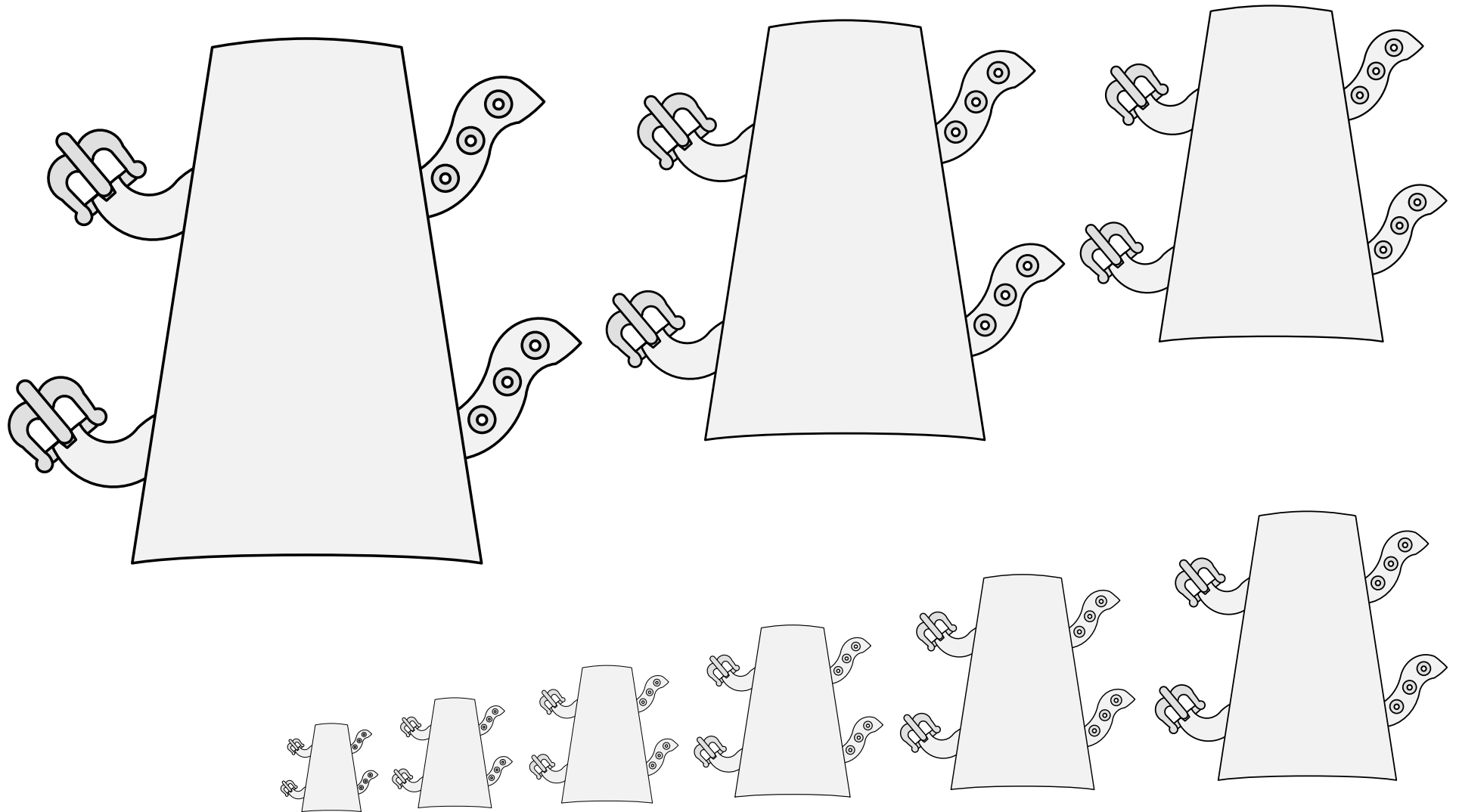

Protection for an archer's forearm.

No default orientation. No proper coloration.

Source: Viking Answer Lady SVG Images For Heraldists. Artist: Gunnvör silfrahárr.

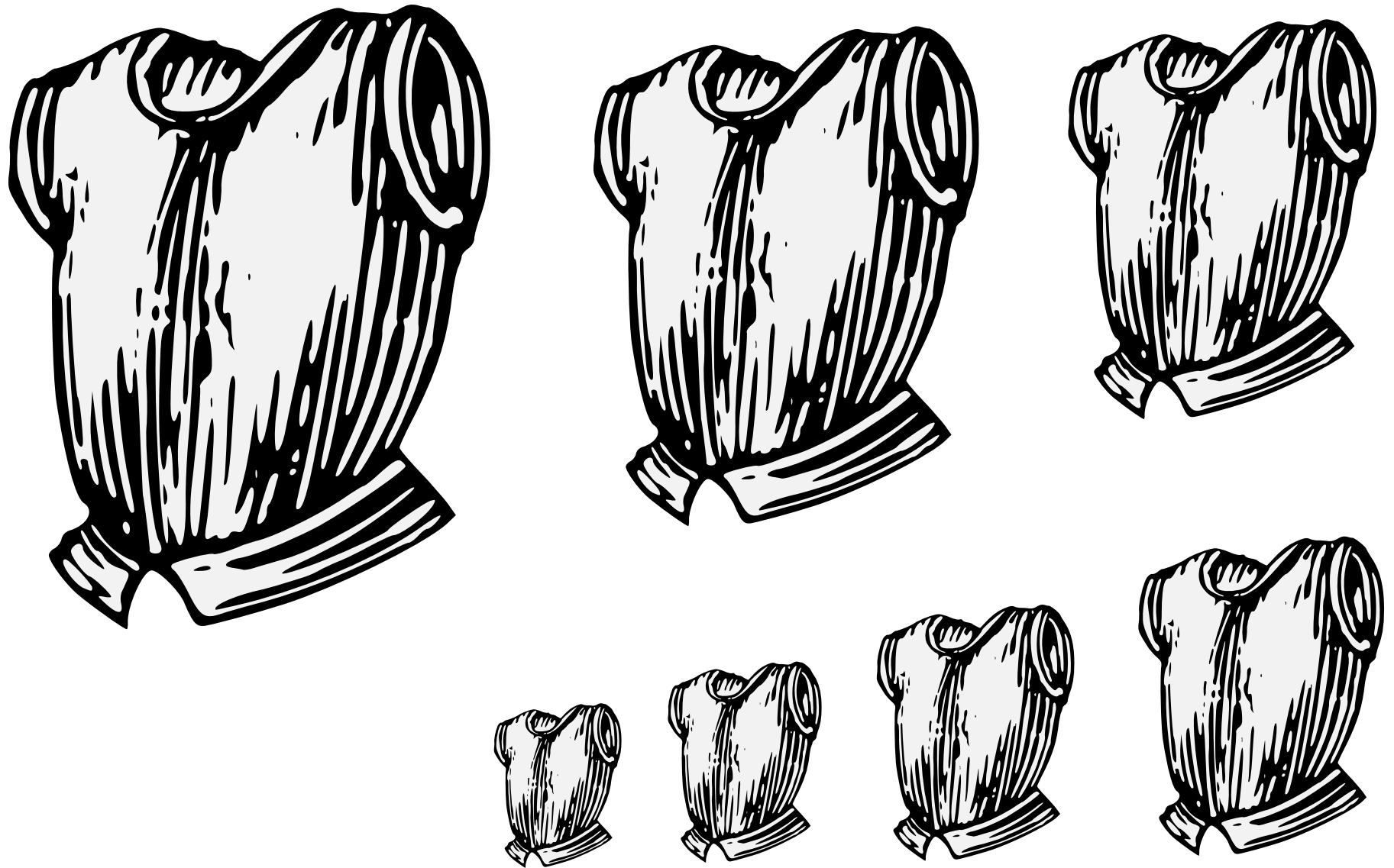

A piece of armor for the torso.

Default orientation: upright. No proper coloration.

Source: Devises et Emblemes Anciennes & Modernes. Artist: Unknown.

Breastplate (1) 21.60



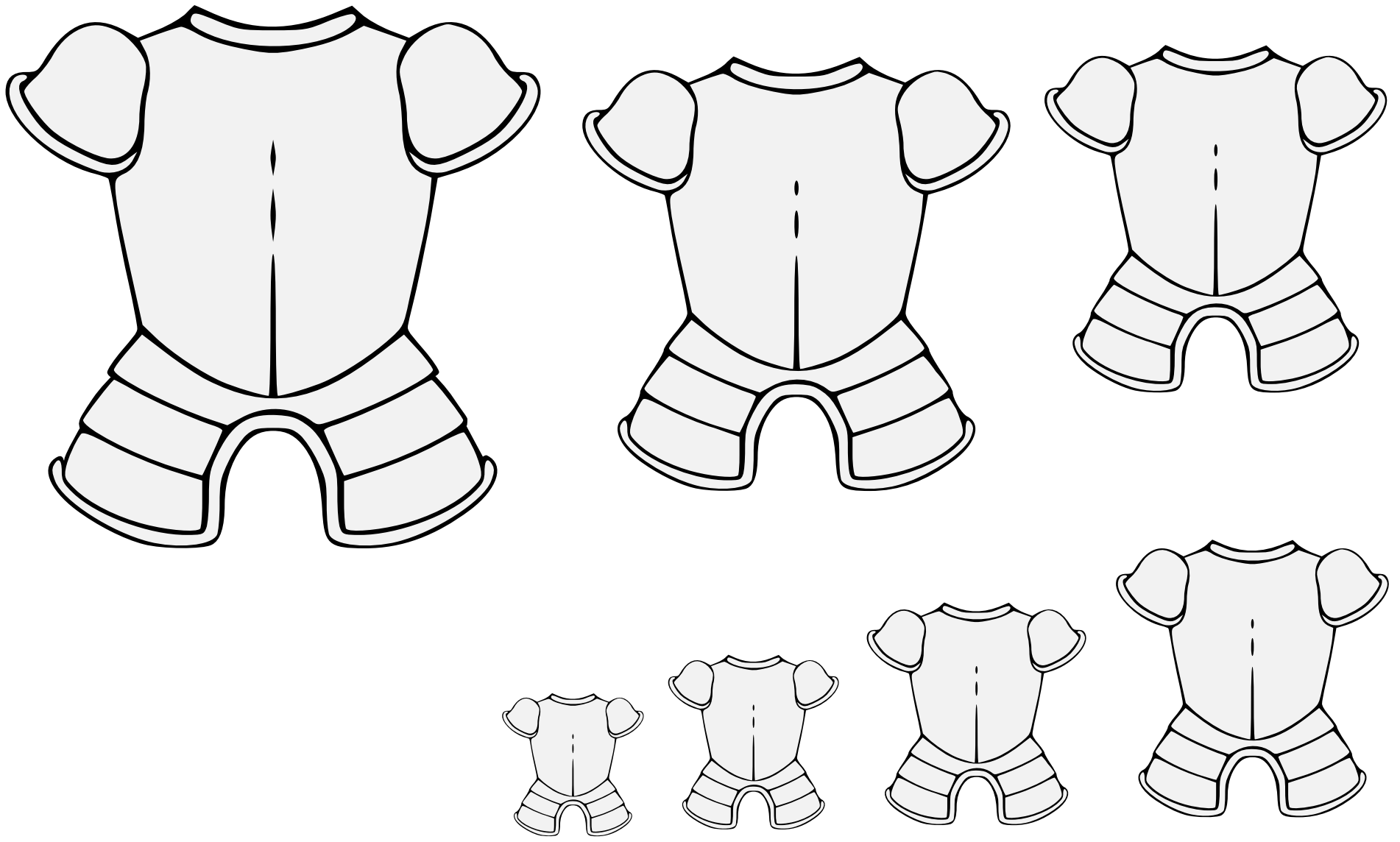

A piece of armor for the torso.  
Default orientation: upright. No proper coloration.  
Source: Heraldik-Wiki. Artist: Leit. License: Public domain.

# Breastplate (2) 21.61

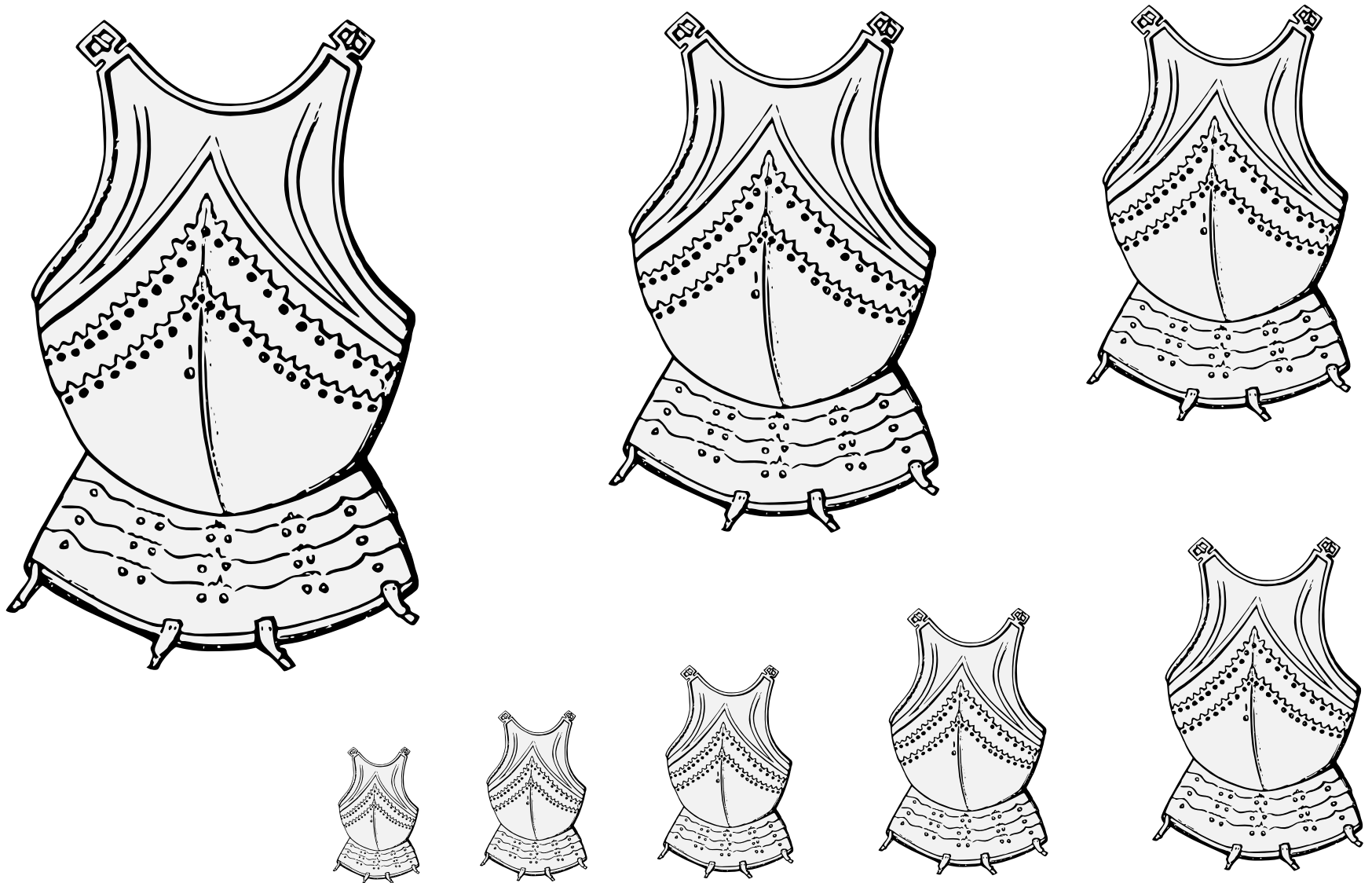

A piece of armor for the torso.

Default orientation: upright. No proper coloration.

Source: A Cyclopedia of Costume. Artist unknown. (Volume I, page 54.)

Breastplate (3) 21.62

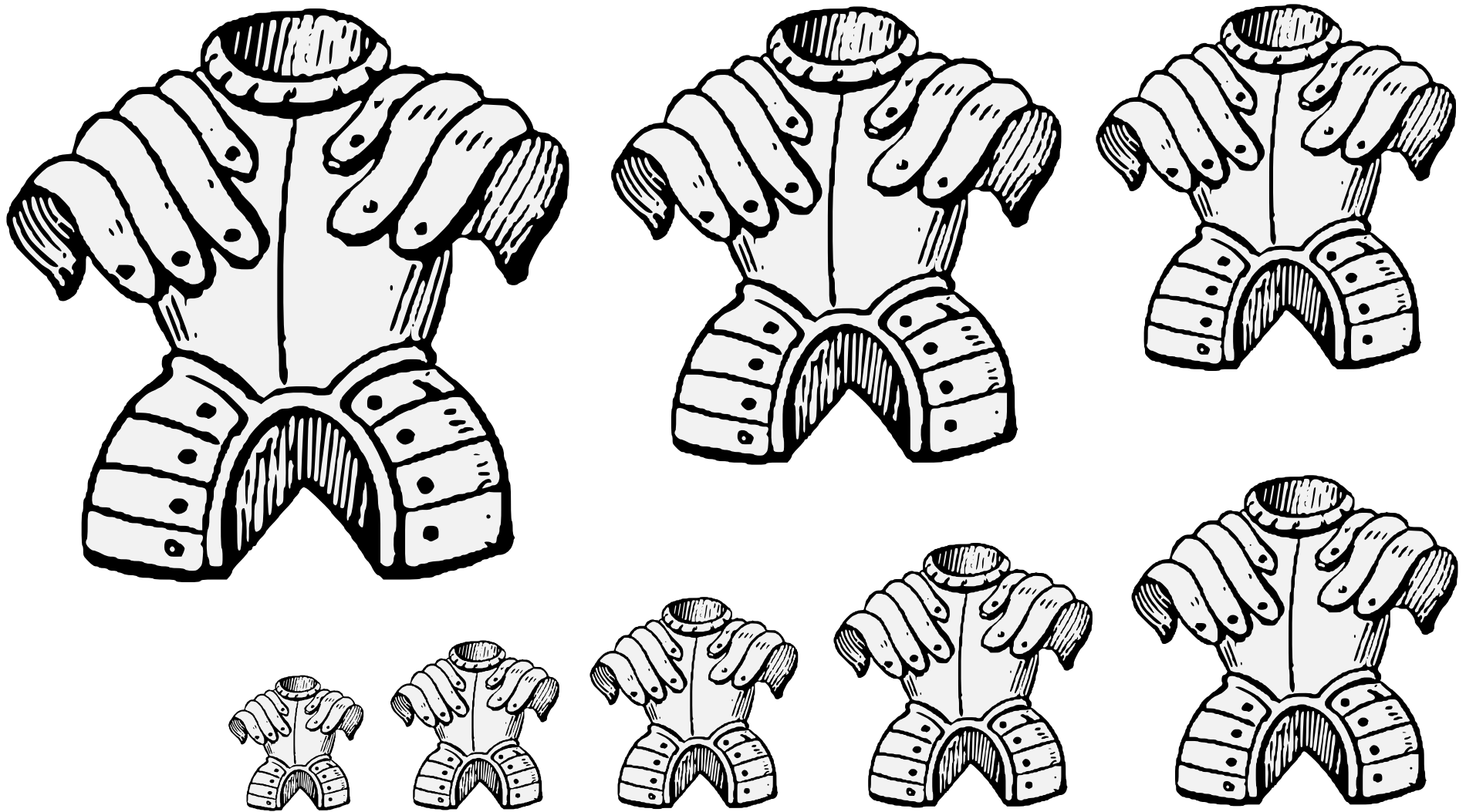

A piece of armor for the torso.

Default orientation: upright. No proper coloration.

Source: Encyclopædia Heraldica. (Volume 3, plate IX.) Artist unknown.

Breastplate (4) 21.63

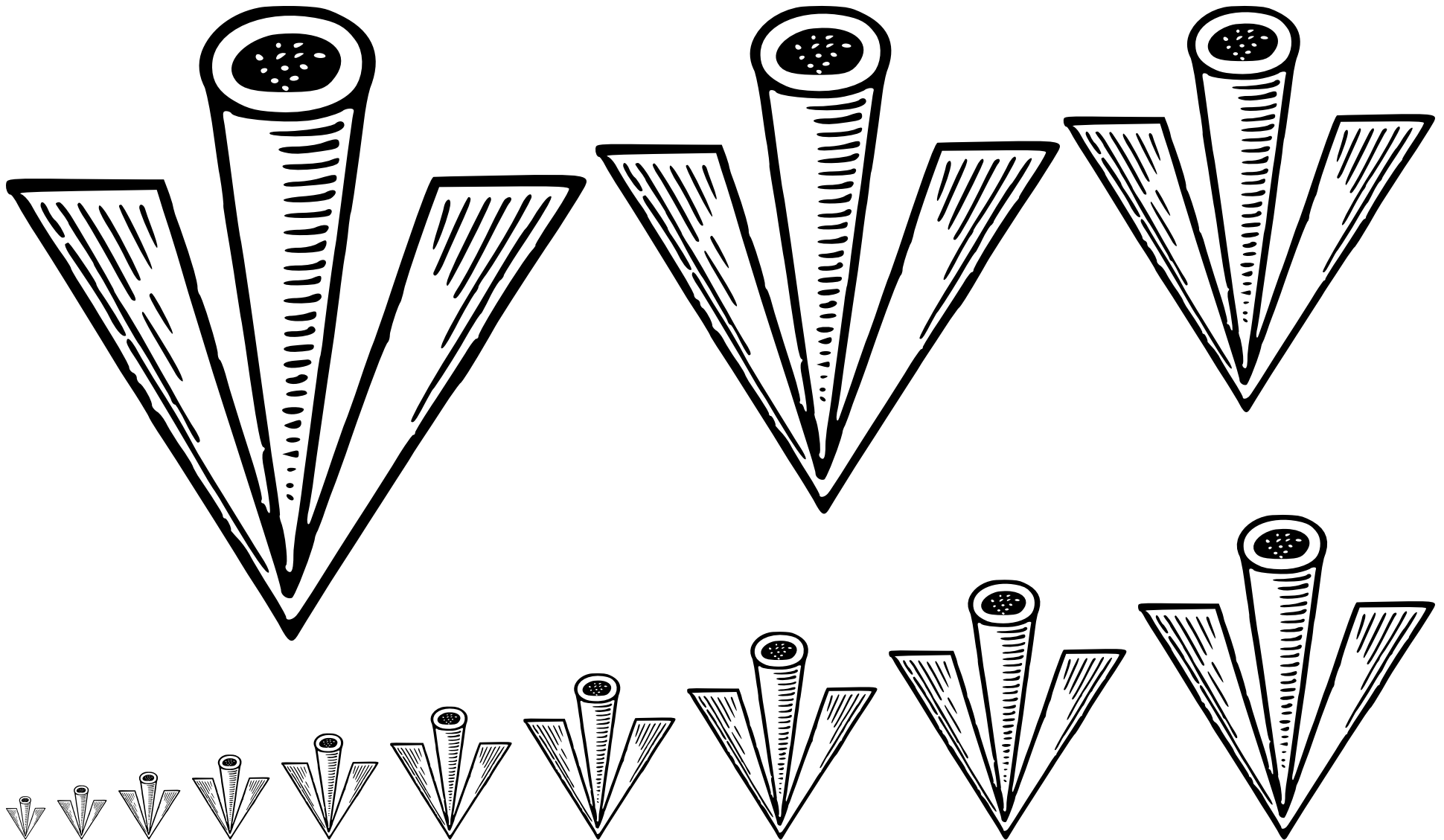

An arrowhead with straight inner edges.

See also Pheon.

Default orientation: point to base. No proper coloration.

Source: A Complete Guide to Heraldry. Artist: Graham Johnston.

Broad-arrow (1) 21.64

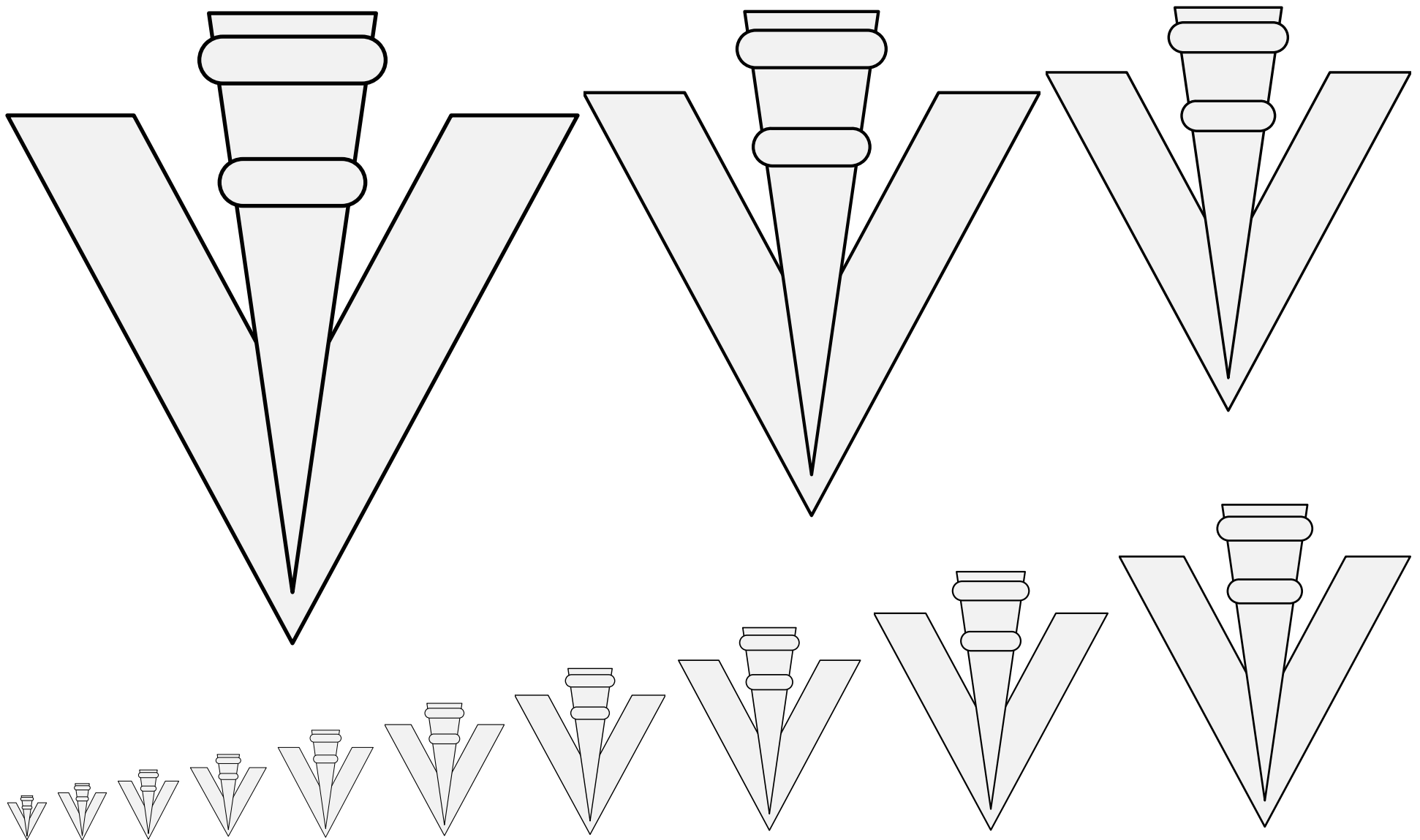

An arrowhead with straight inner edges. See also Pheon.

Default orientation: point to base. No proper coloration.

Source: Viking Answer Lady SVG Images For Heralds. Artist: Gunnvôr silfráhr.

**Broad-arrow (2) 21.65**

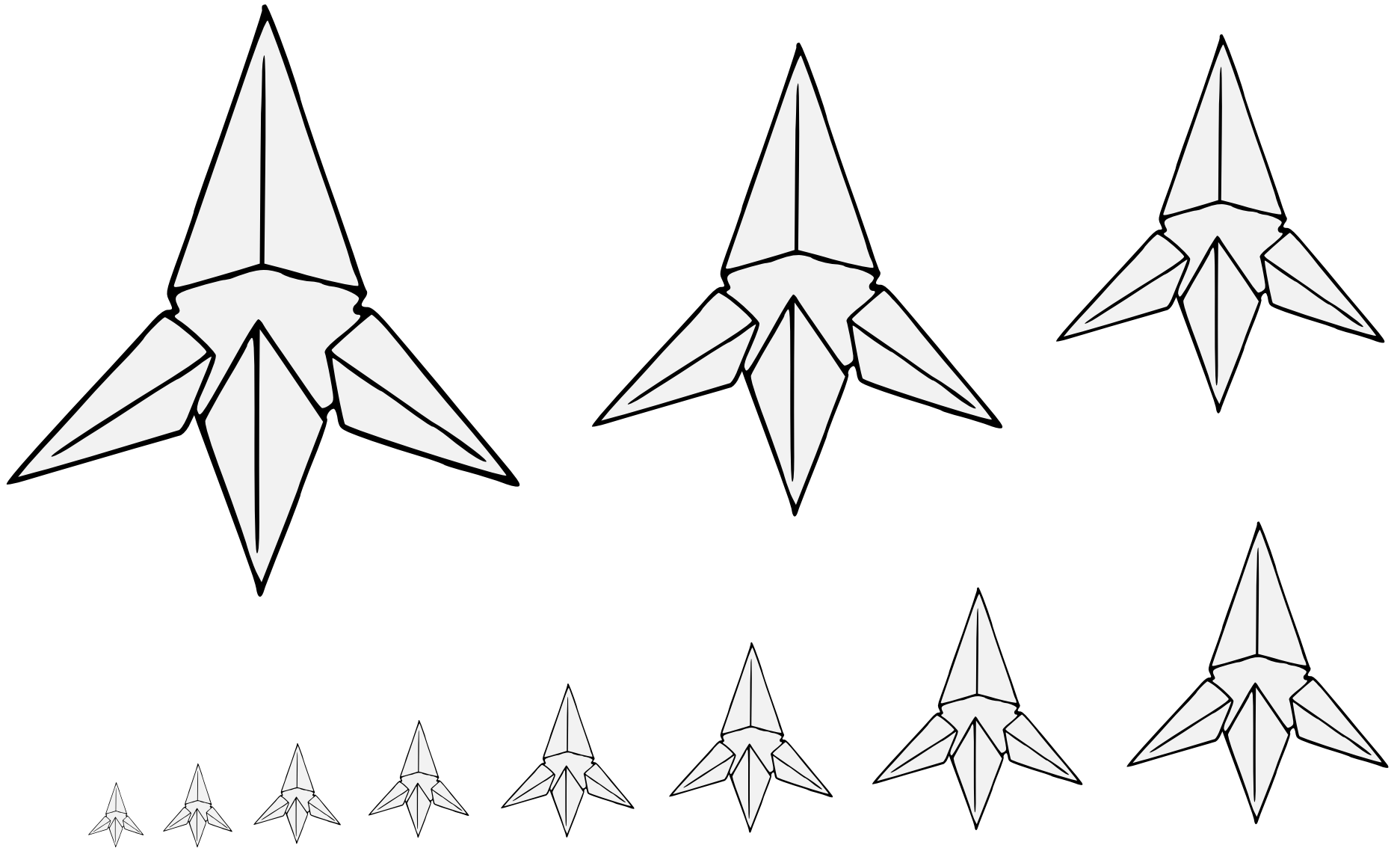

A military obstacle, designed to rest point up and endanger those who might step upon it.

Default orientation: point to chief. No proper coloration.

Source: Pennsic Traceable Art. Artist: Unknown.

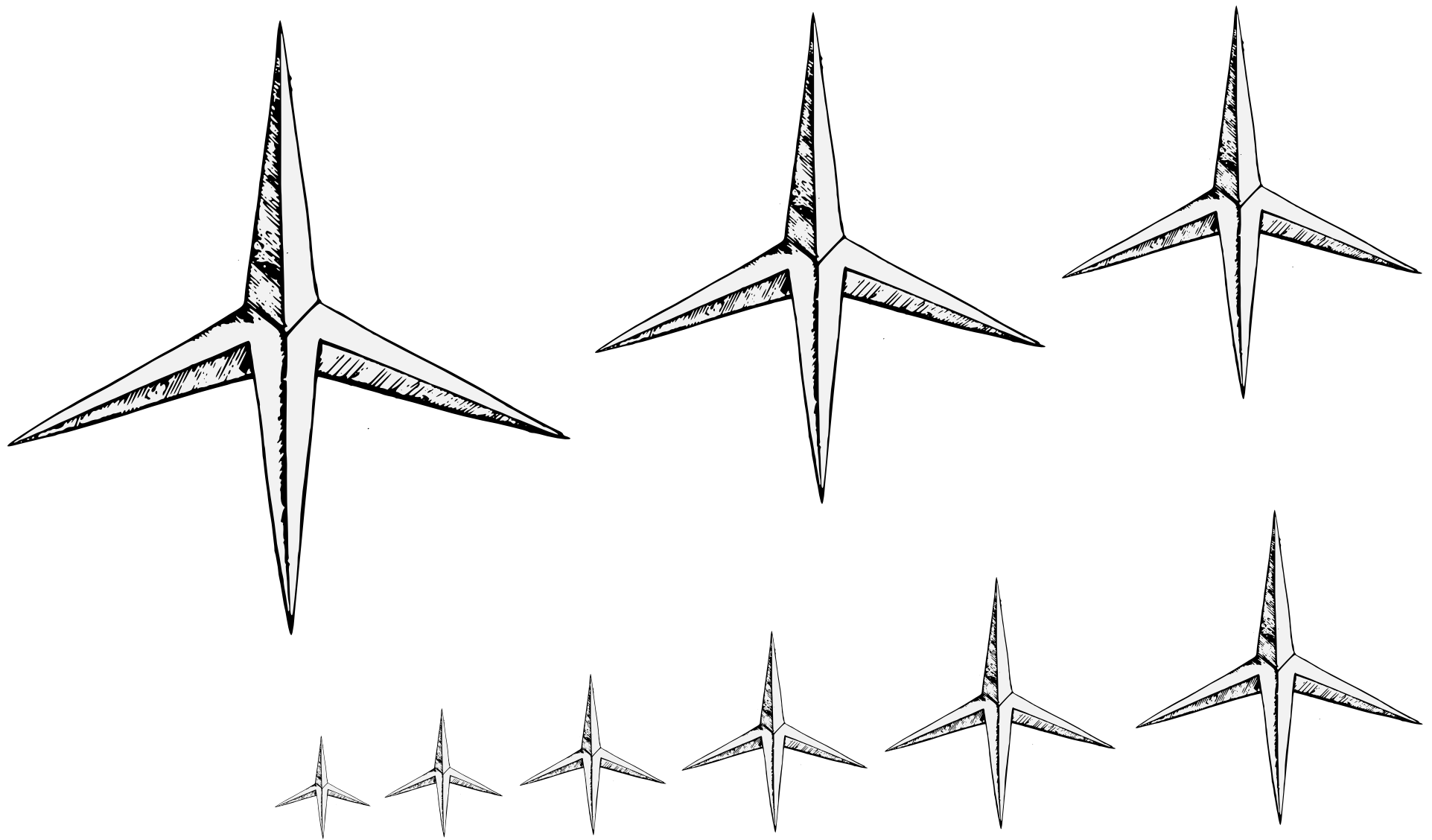

A military obstacle, designed to rest point up and endanger those who might step upon it.

Default orientation: point to chief. No proper coloration.

Source: Devises Heroiques et Emblemes. Artist unknown. (Page 197.)

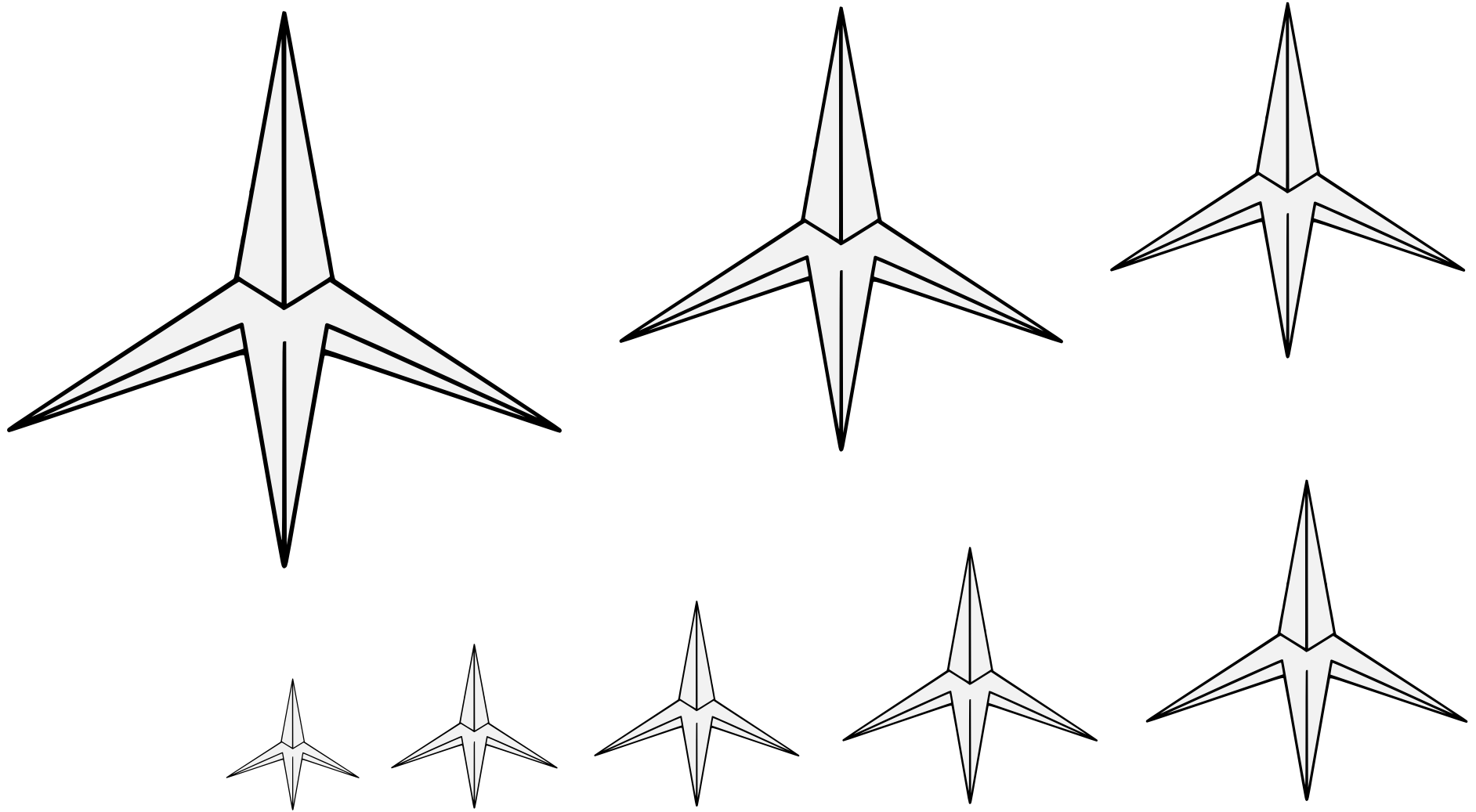

A military obstacle, designed to rest point up and endanger those who might step upon it.

Default orientation: point to chief. No proper coloration.

Artist: Jessimond of Emerickeskepe.



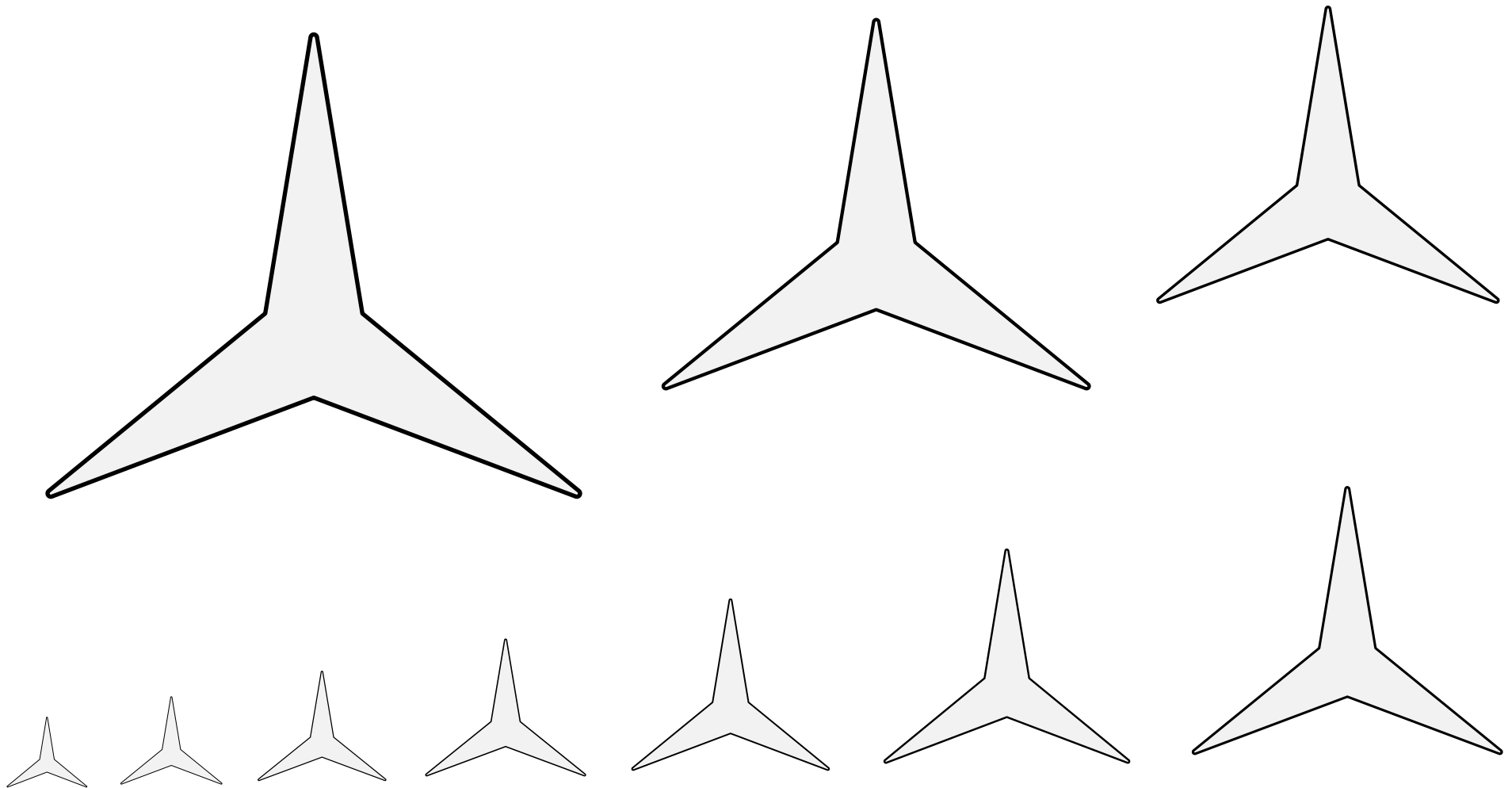

A military obstacle, designed to rest point up and endanger those who might step upon it.

Default orientation: point to chief. No proper coloration.

Source: Des Kaiserlichen Kammergerichts zu Speier Kammerrichter.  
Artist unknown. (Page 125.)

Caltrop (4) • 21.69

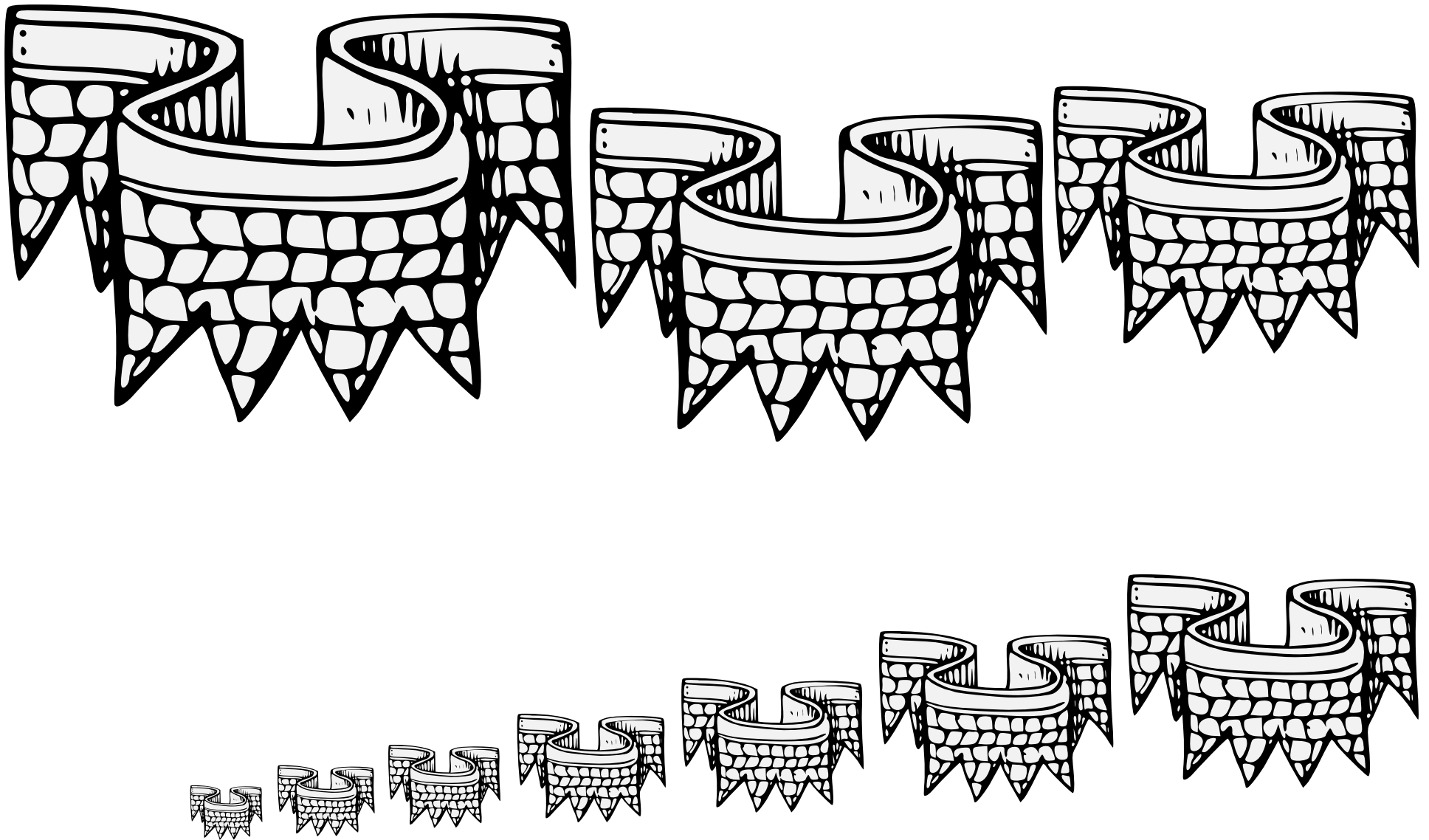

A band of chain mail hung from the edge of a helmet to protect the neck. May be blazoned an “aventail” or “skirt of mail.”

Default orientation: point to base. No default coloration.

Source: Banners, Standards, and Badges. Artist: Thomas Willement.

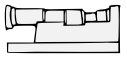
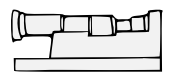
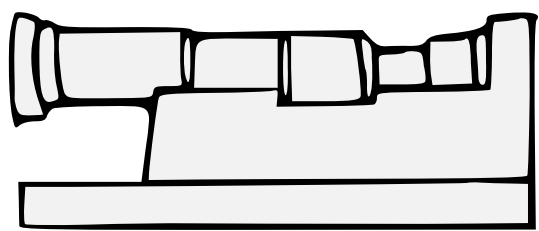
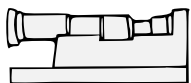
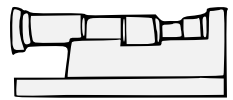
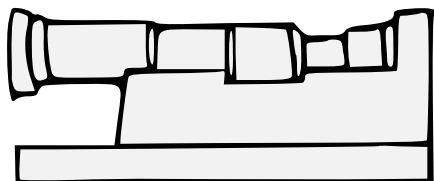
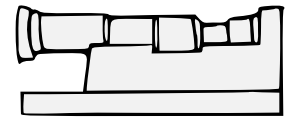
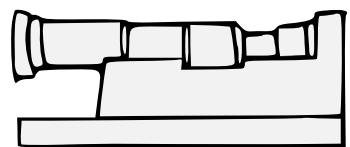
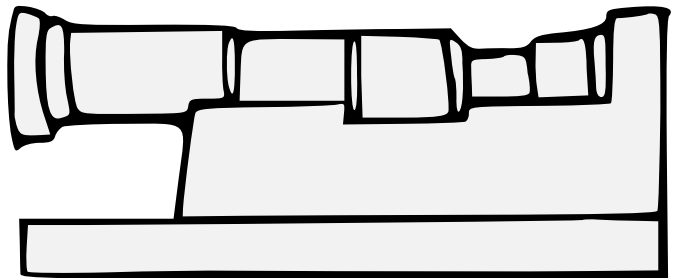
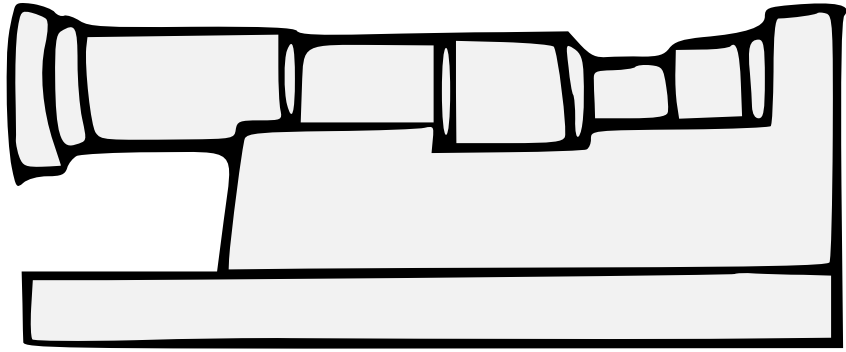

A large gun.  
Default orientation: aiming to dexter. No proper coloration.  
Source: Pennsic Traceable Art. Artist: Unknown.

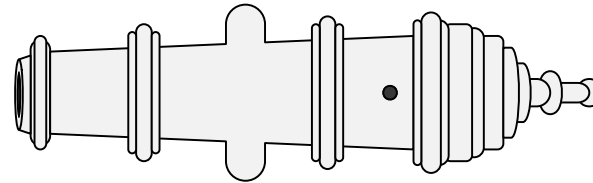
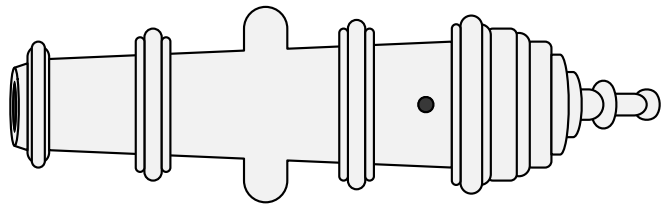
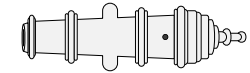
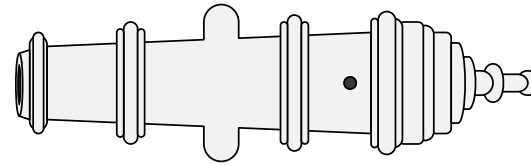
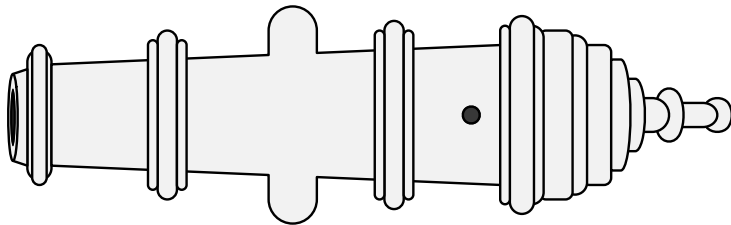
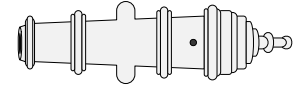
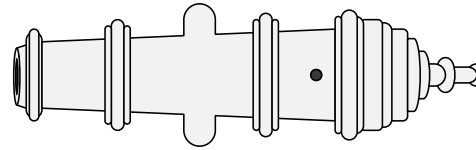
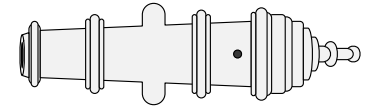
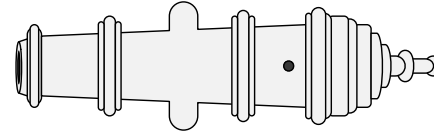
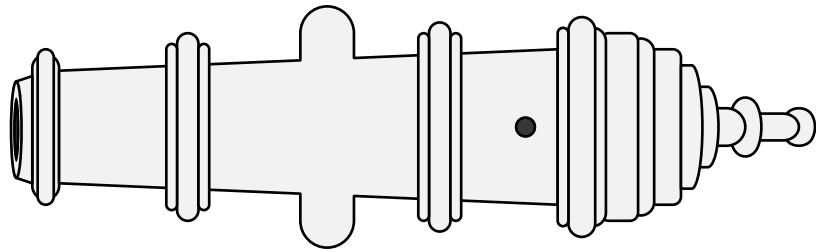

A large gun.

Default orientation: aiming to dexter. No proper coloration.

Source: Queens College MS 72. Artist unknown. (Folio 124r.)

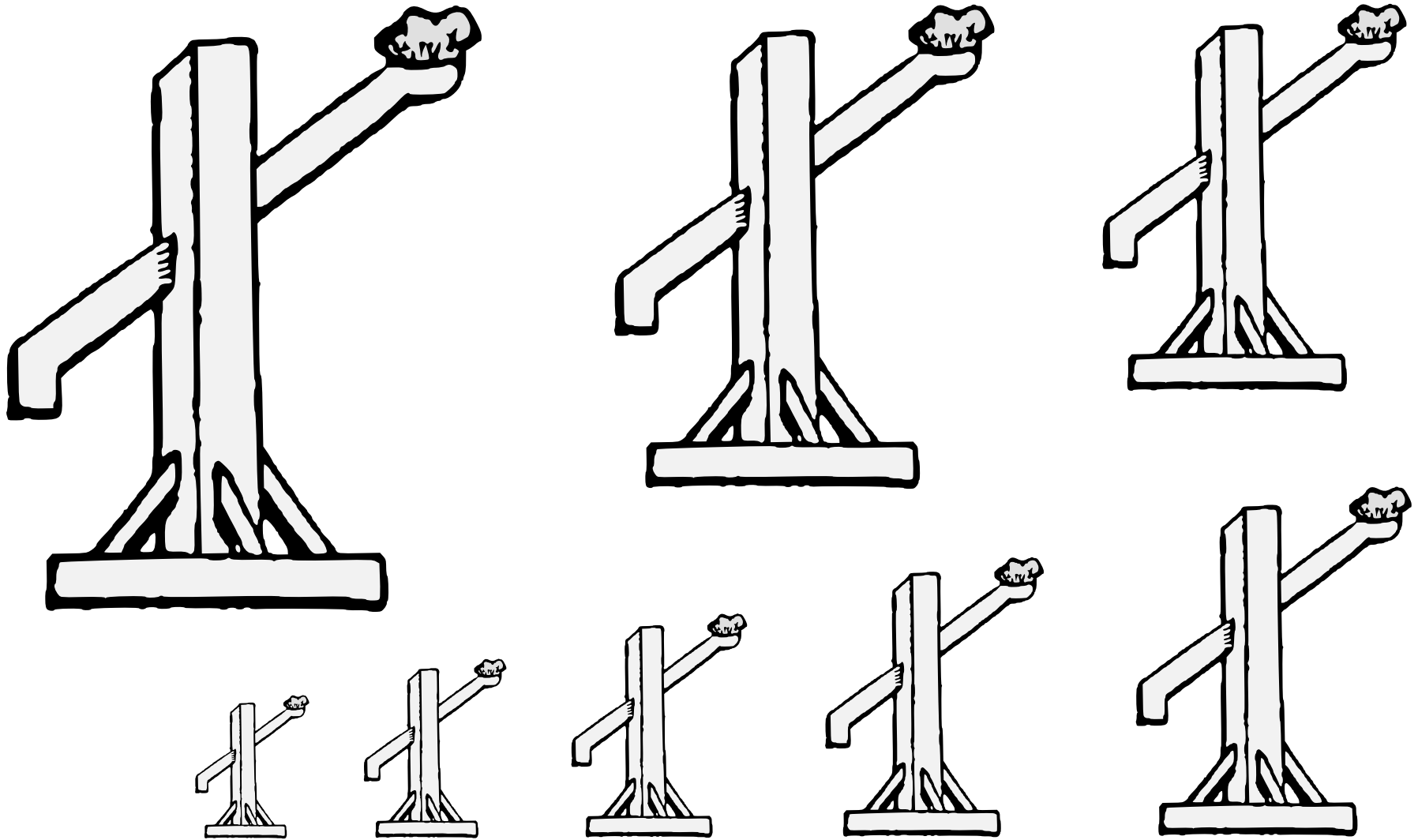

A machine for throwing stones.

Default orientation: upright. Proper coloration: brown wood.

This variety is also blazoned a "swepe" due to its similarity to the long lever used to raise pails of water from a well.

Source: Encyclopædia Heraldica.  
(Volume 3, plate IX.) Artist unknown.

Catapult (1) 21.73

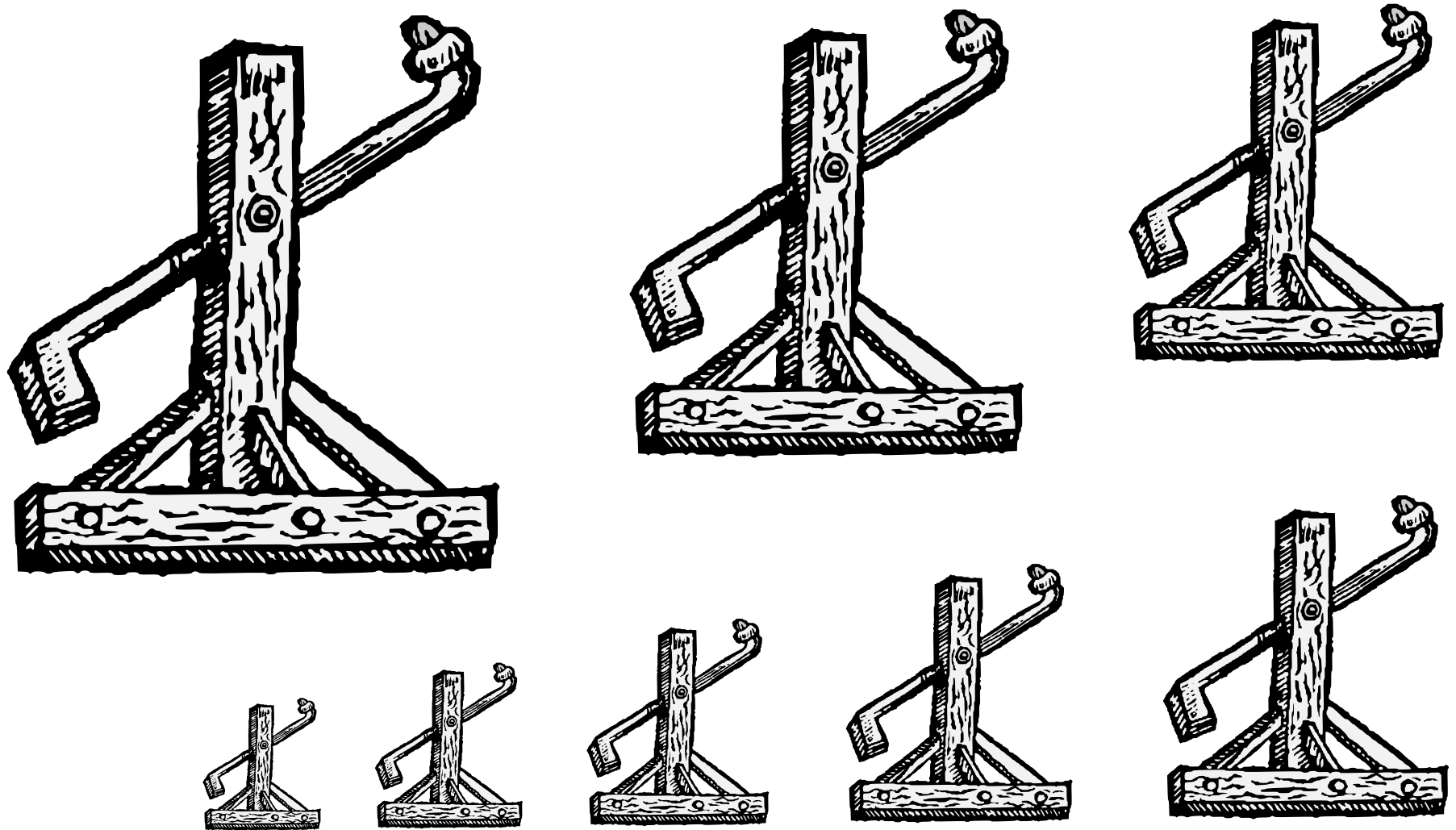

A machine for throwing stones.

Default orientation: upright. Proper coloration: brown wood.

This variety is also blazoned a "swepe" due to its similarity to the long lever used to raise pails of water from a well.

Source: Guillim's Display of Heraldry.

Artist unknown. (Edition of 1679, page 245.)

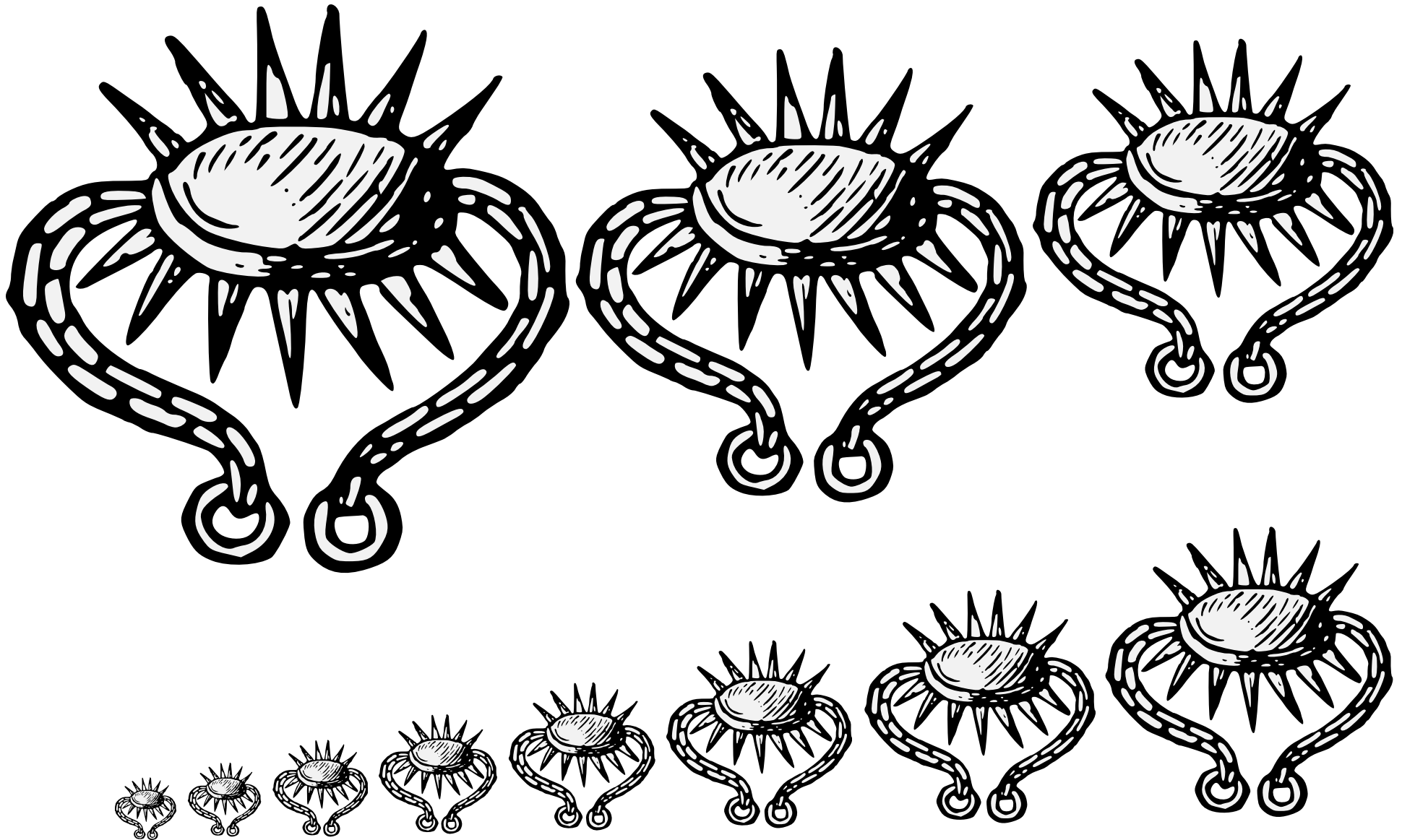

Used as cannon ammunition used to snap ships' rigging, or as an anti-personnel weapon.

No default orientation. No proper coloration.

Source: Guillim's Display of Heraldry. Artist unknown.

Chaine Shot (1) 21.75

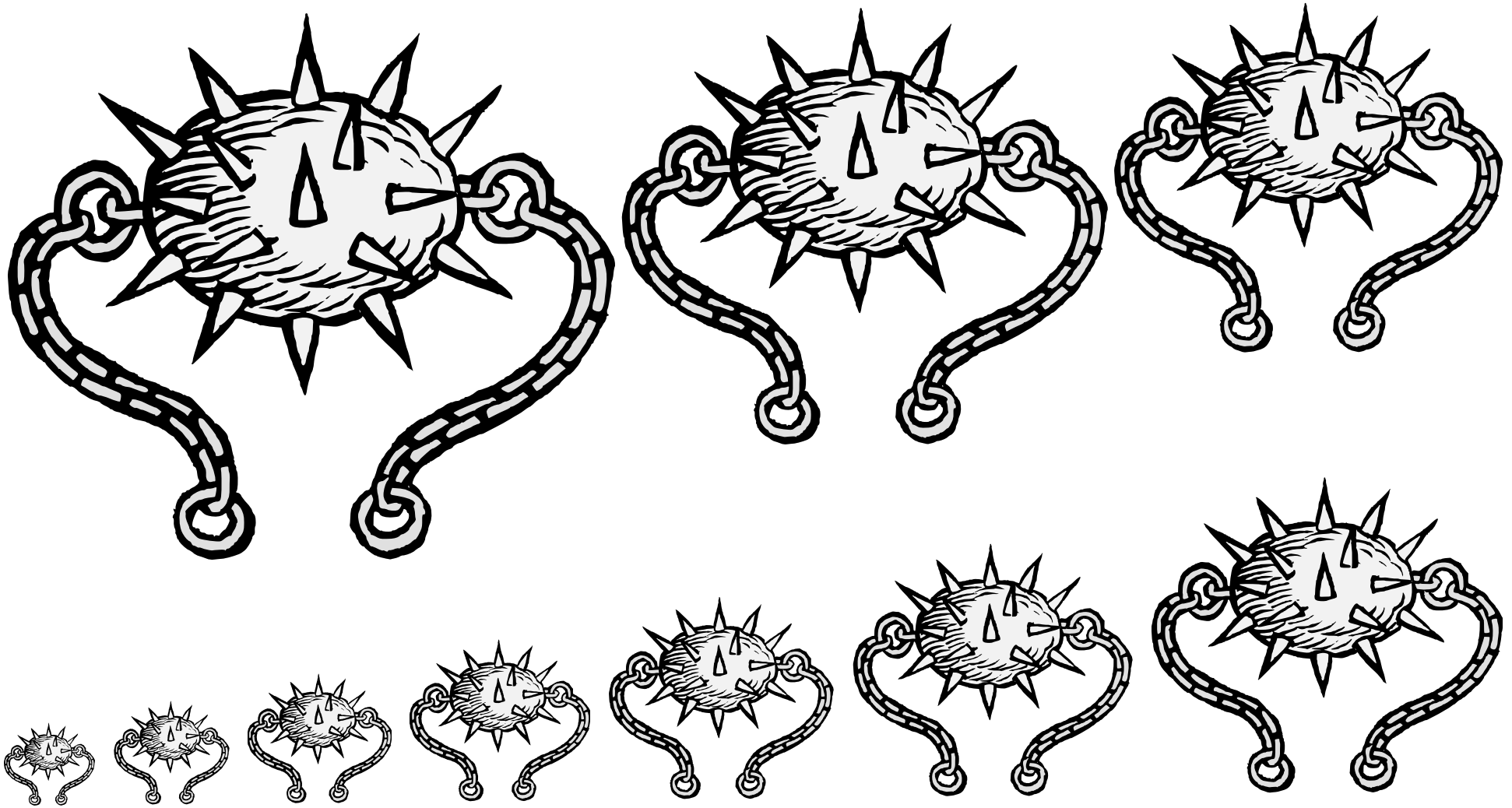

Used as cannon ammunition used to snap ships' rigging, or as an anti-personnel weapon.

No default orientation. No proper coloration.

Source: The Elements of Armories. Artist unknown.  
(Page 164.) Adapted by Iago ab Adam.

Chaine Shot (2) 21.76



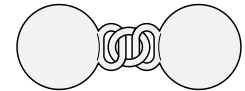
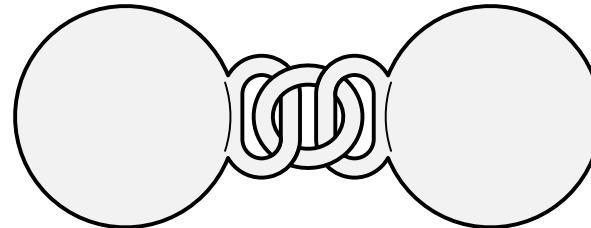
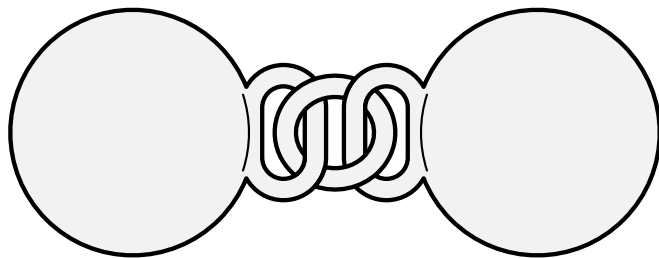
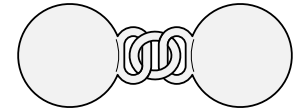
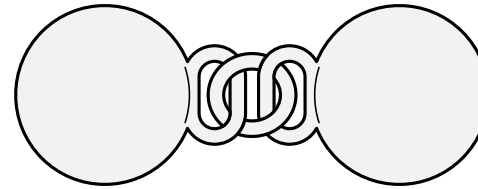
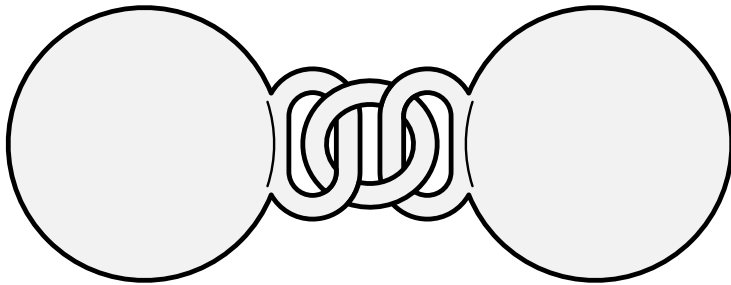
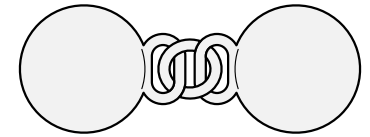
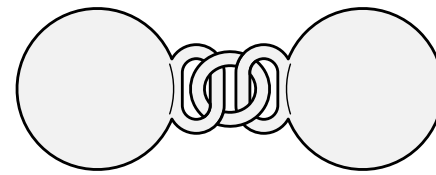
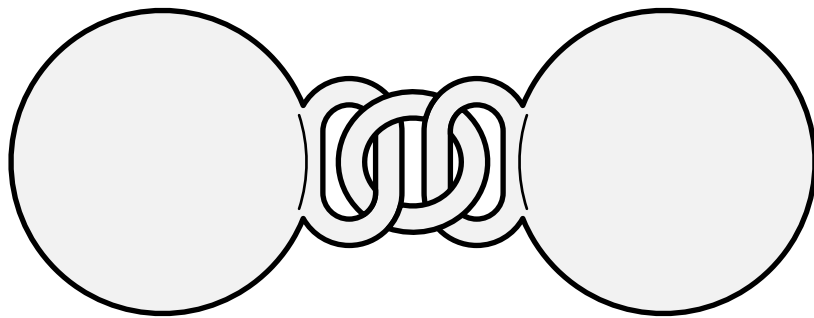

Used as cannon ammunition used to snap ships' rigging, or as an anti-personnel weapon.

No default orientation. No proper coloration.

Adapted from images of shot recovered from the wreck of the Vasa.

Chaine Shot (3) 21.77

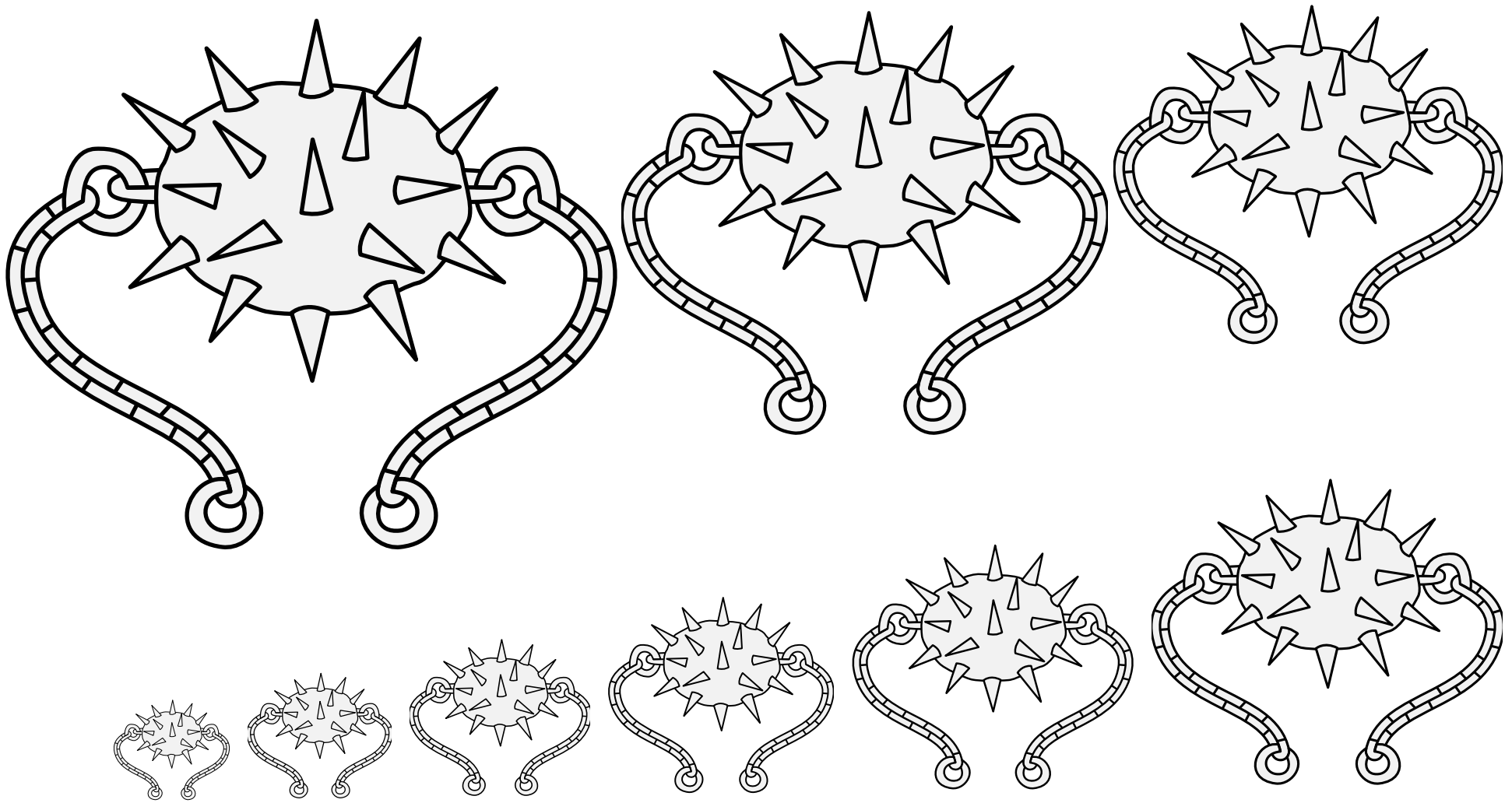

Used as cannon ammunition used to snap ships' rigging, or as an anti-personnel weapon.

No default orientation. No proper coloration.

Source: The Elements of Armories. Artist unknown.  
(Page 164.) Adapted by Ilzolende.

Chaine Shot (4) 21.78

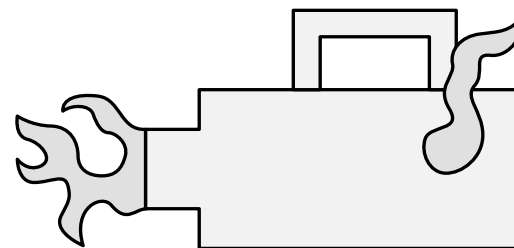
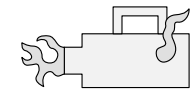
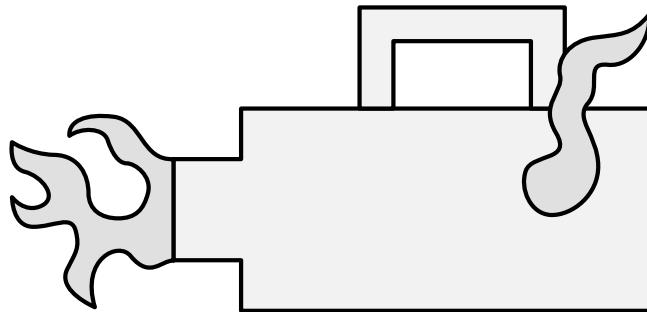
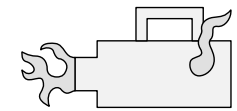
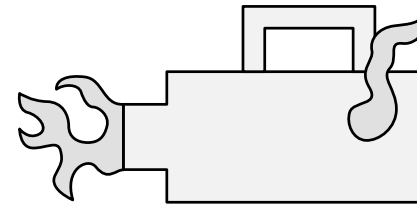
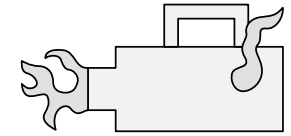
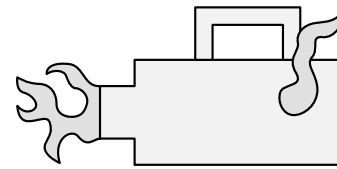
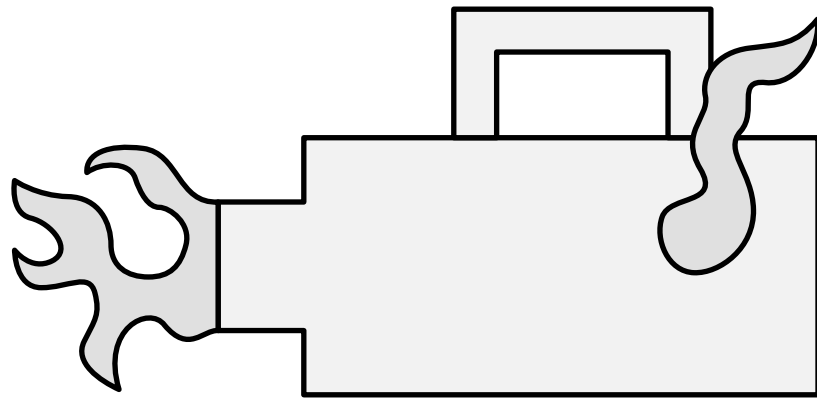

A cartridge containing a powder charge to be loaded into the breach of a canon.

Default orientation: fesswise, firing to dexter. No proper coloration.

Source: University of Victoria Ms. Brown.Eng.2. Artist unknown.

Adapted by Mathghamhain Ua Ruadháin.

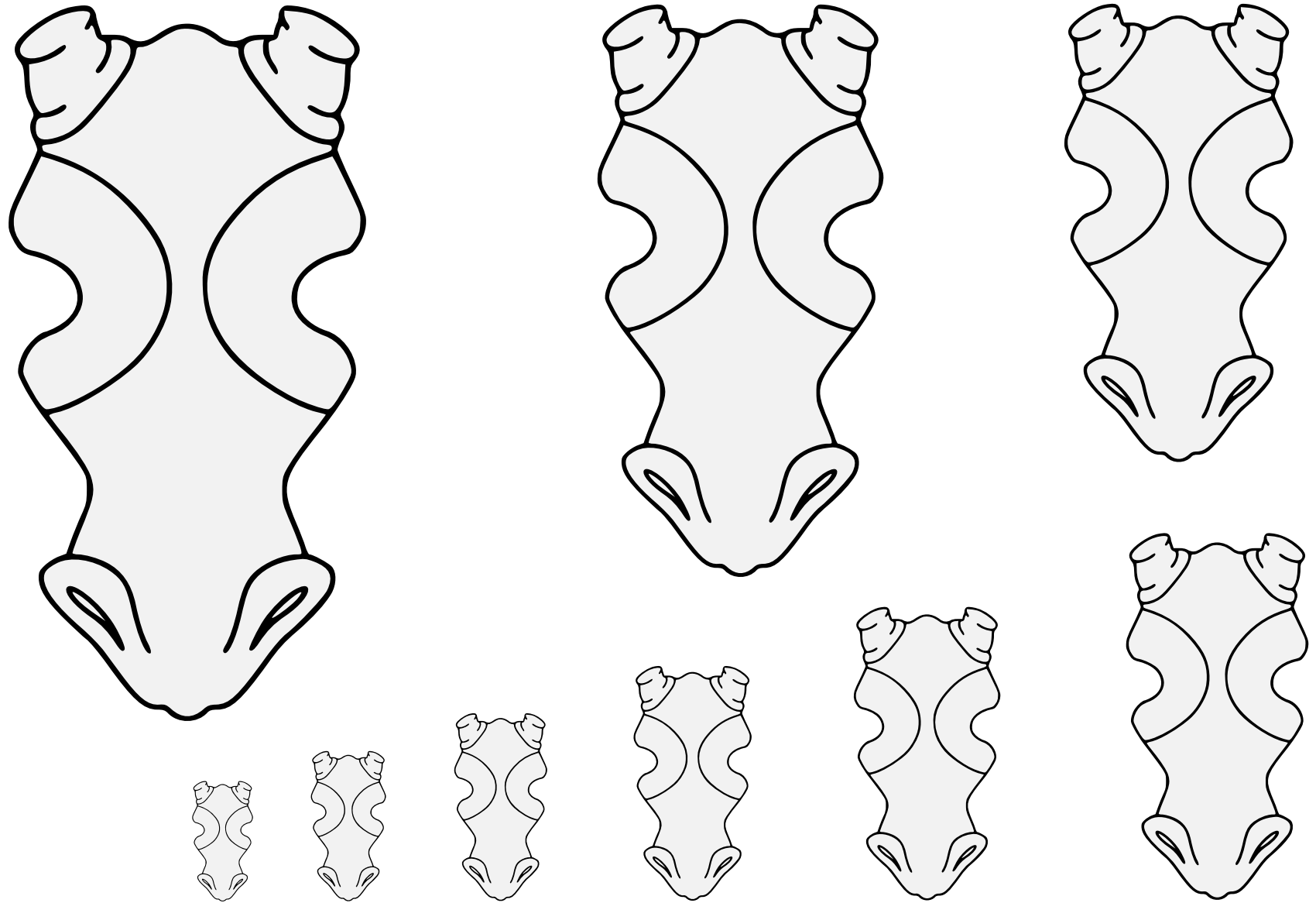

Armor for a horse's head.

Default orientation: affronty and upright. No proper coloration.

Source: Sledgehammer. Artist: Grimwulf Harland.

**Chamfron** 21.80

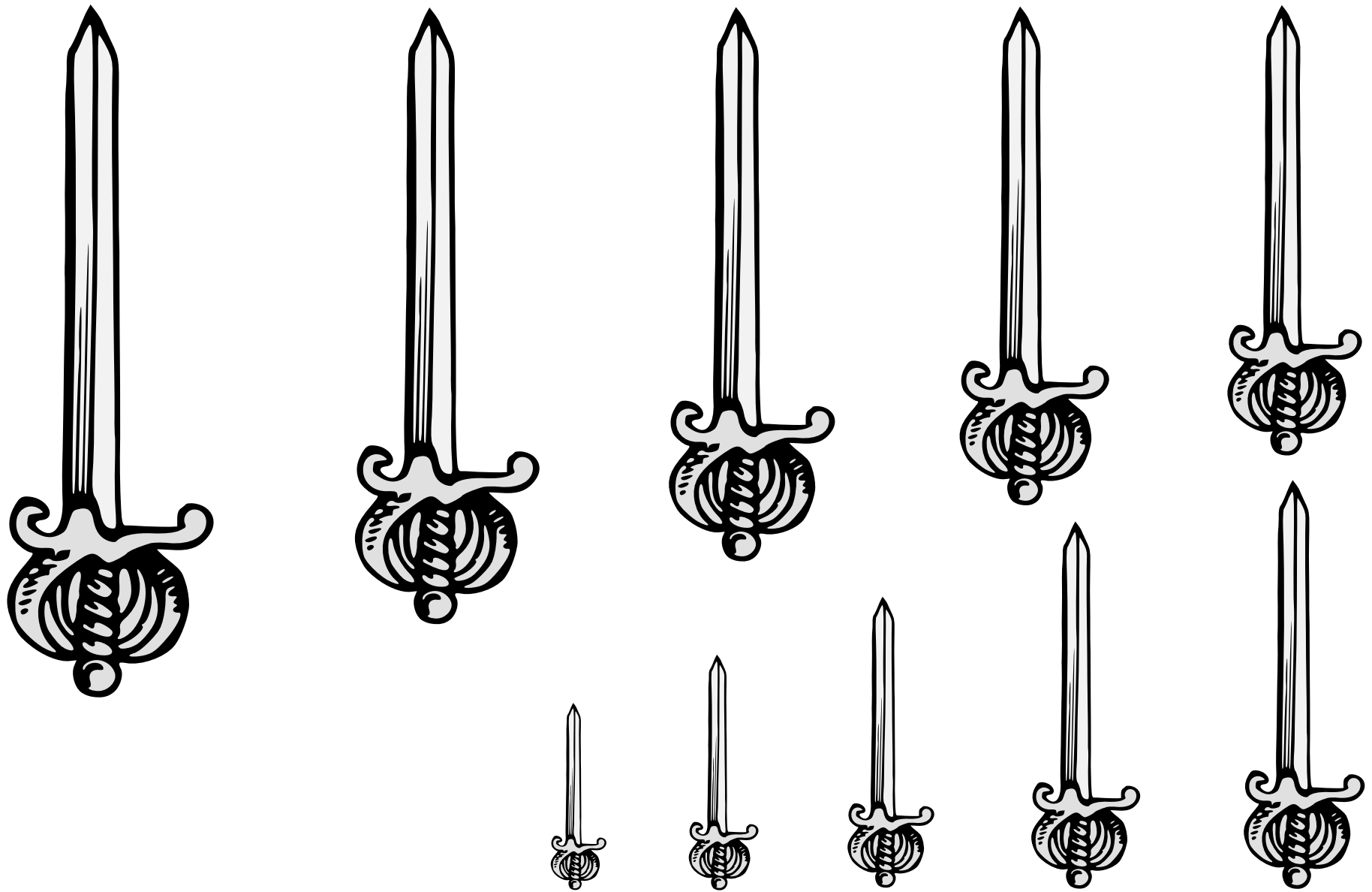

A Scottish great sword, featuring a basket hilt and forward-swept quillons. The term "claymore" is likely post-period.

Default orientation: point to chief. Proper coloration: blade argent, hilt Or.

Source: Vocabulaire-Atlas Héraldique. Artist unknown. (Illustration 414.)

Claymore 21.81

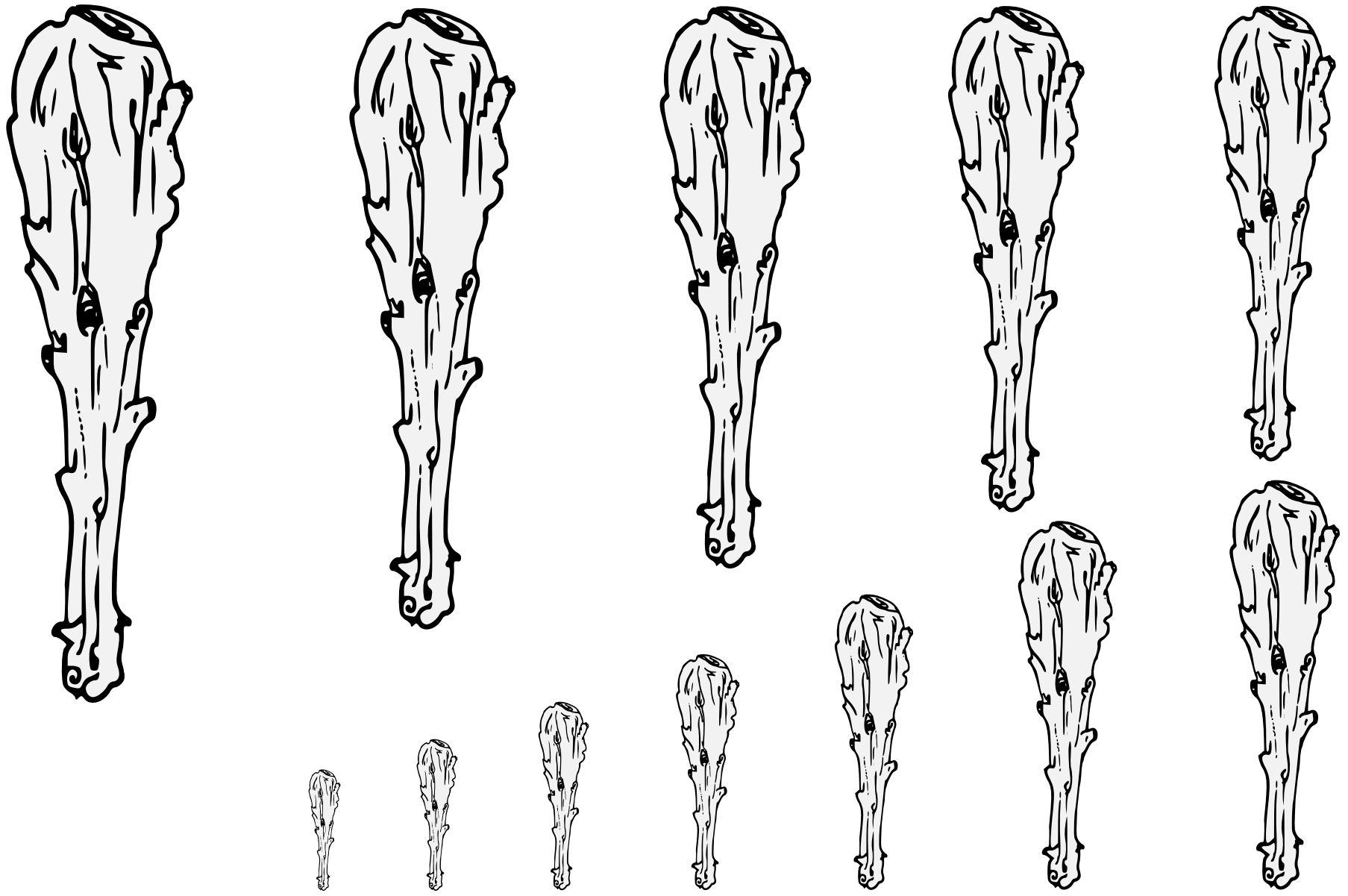

A heavy, rough-hewn piece of wood used as a weapon.

Default orientation: palewise, handle to base. Proper coloration: brown wood.

Source: Pennsic Traceable Art. Artist unknown.

Club (1) 21.82

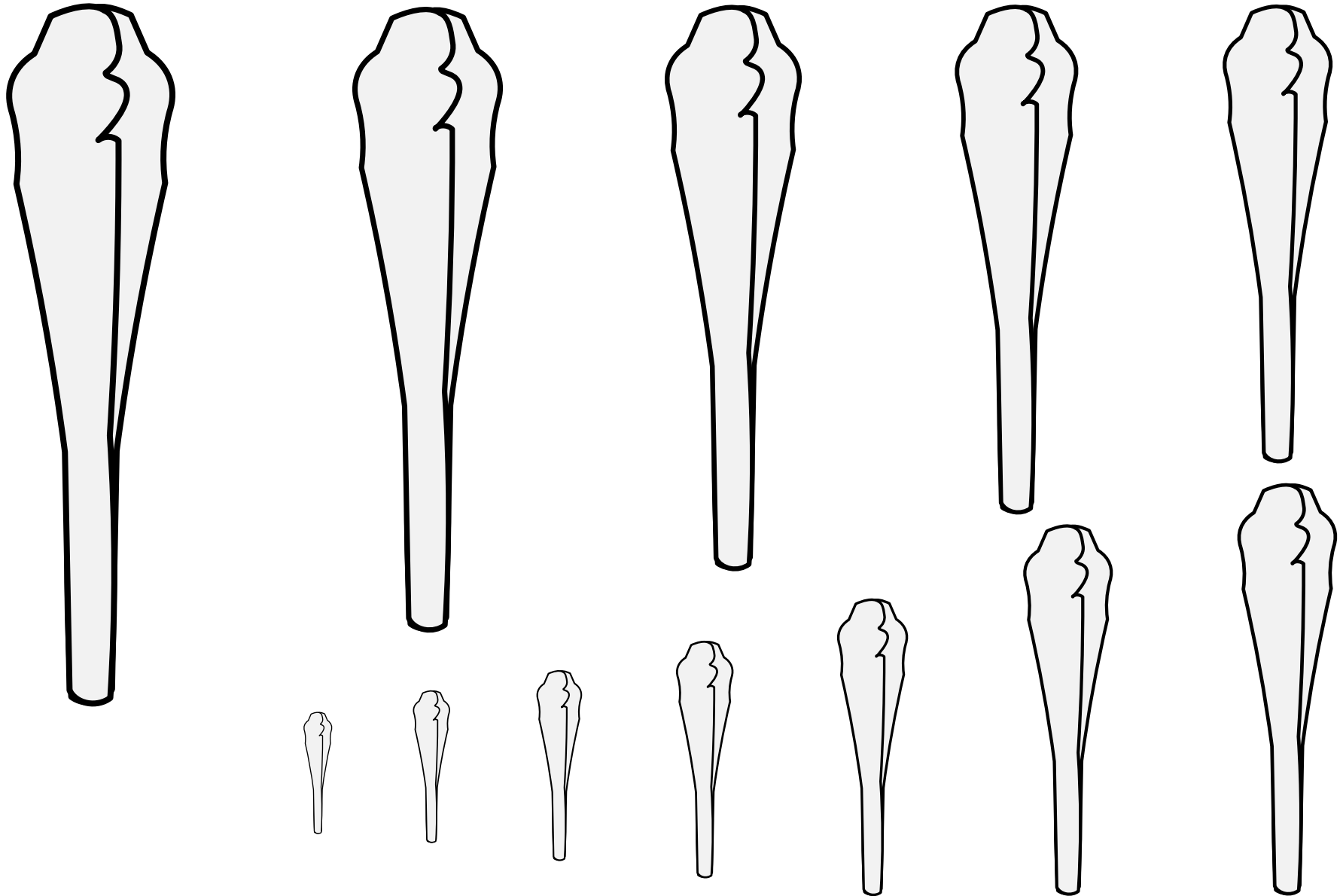

A heavy, rough-hewn piece of wood used as a weapon.

Default orientation: palewise, handle to base. Proper coloration: brown wood.

Source: Viking Answer Lady SVG Images For Heraldry.

Artist: Gunnvôr silfrhárr. Adapted by Mathghamhain Ua Ruadháin.

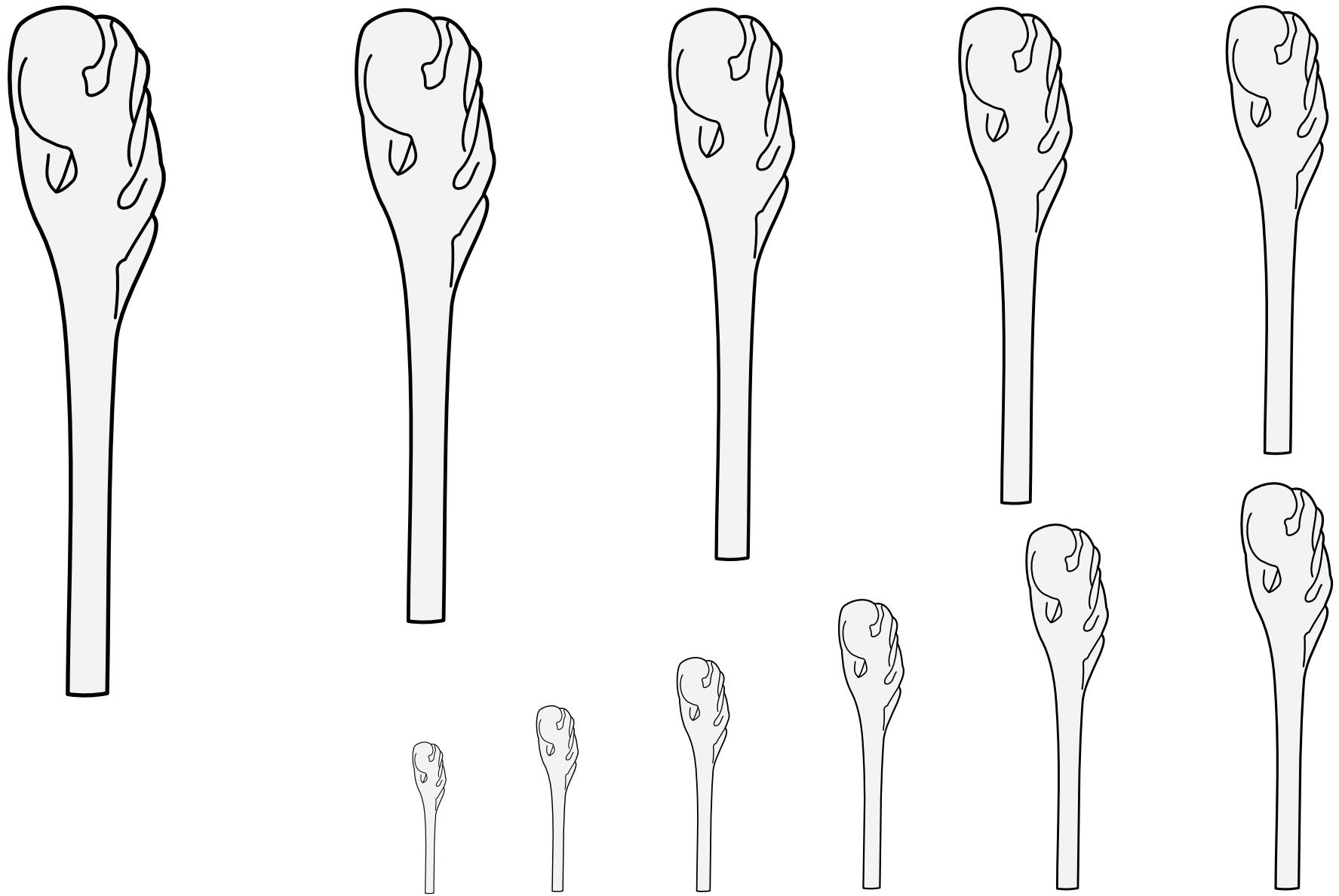

A heavy, rough-hewn piece of wood used as a weapon.

Default orientation: palewise, handle to base. Proper coloration: brown wood.

Source: A Display of Heraldry. Artist: John Guillim. (Manuscript.) Adapted by Iago ab Adam.





A metal end-cap used to reinforce the end of a scabbard.

Default orientation: point to base. No default coloration.

Source: Banners, Standards, and Badges. Artist: Thomas Willement.  
(Banner of de la Warr, p. 184.)

Crampet (1) 21.85

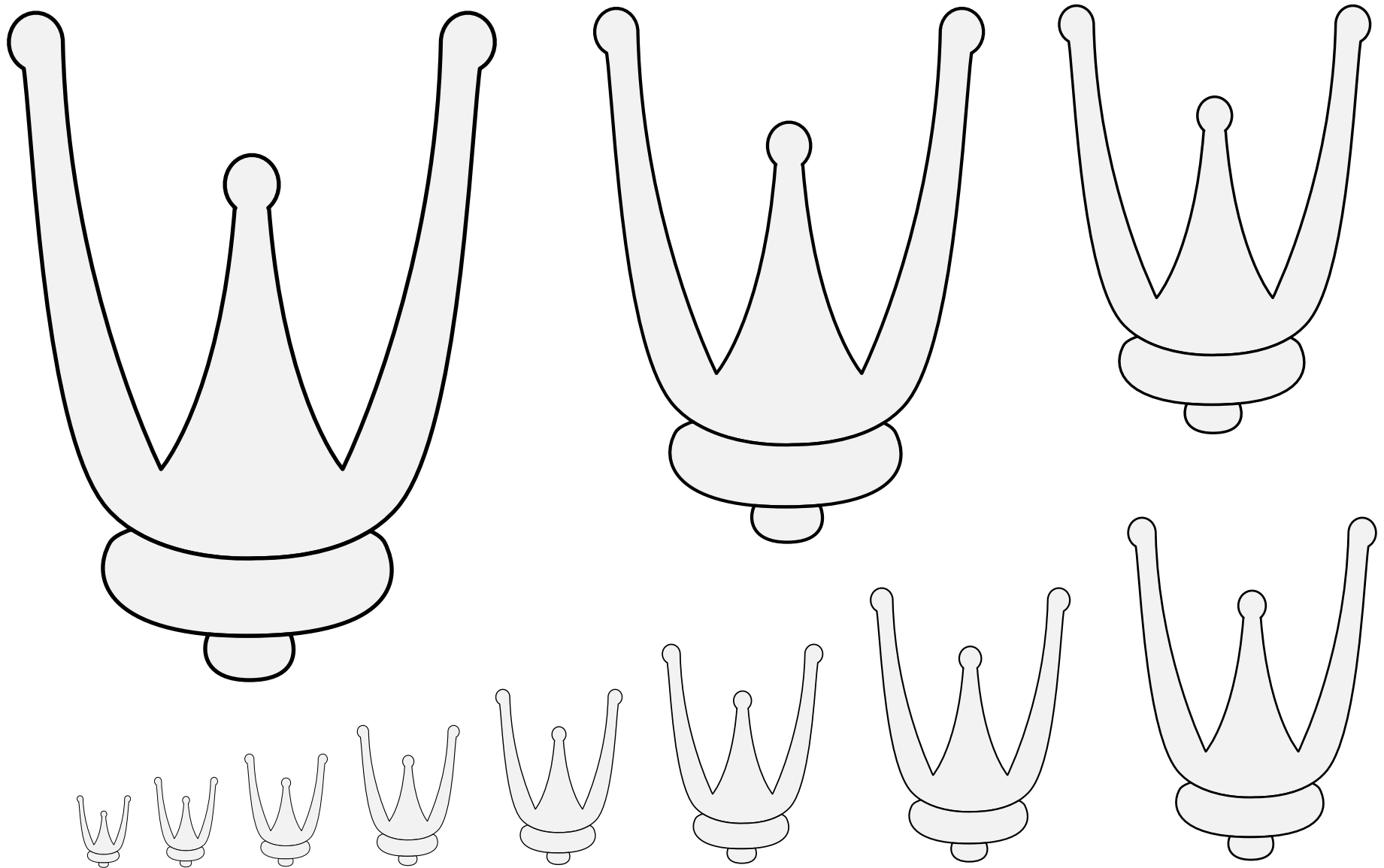

A metal end-cap used to reinforce the end of a scabbard.

Default orientation: point to base. No default coloration.

Source: A Cyclopedia of Costume. Artist unknown. (Volume I, page 89.)

Crampet (2) 21.86

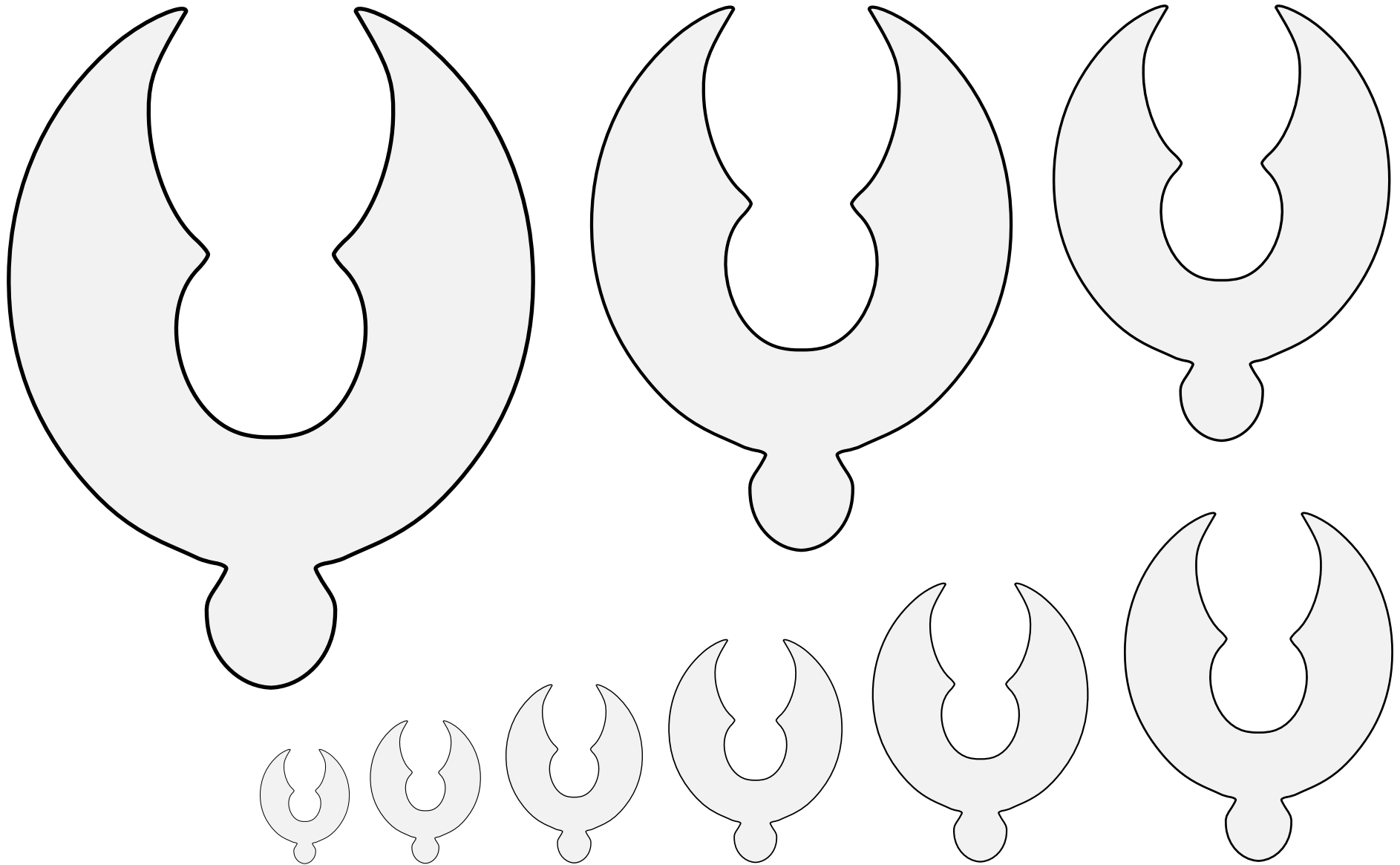

A metal end-cap used to reinforce the end of a scabbard.

Default orientation: point to base. No default coloration.

Source: Vocabulaire-Atlas Héraldique. Artist unknown. (Illustration 417.)

**Crampet (3) • 21.87**

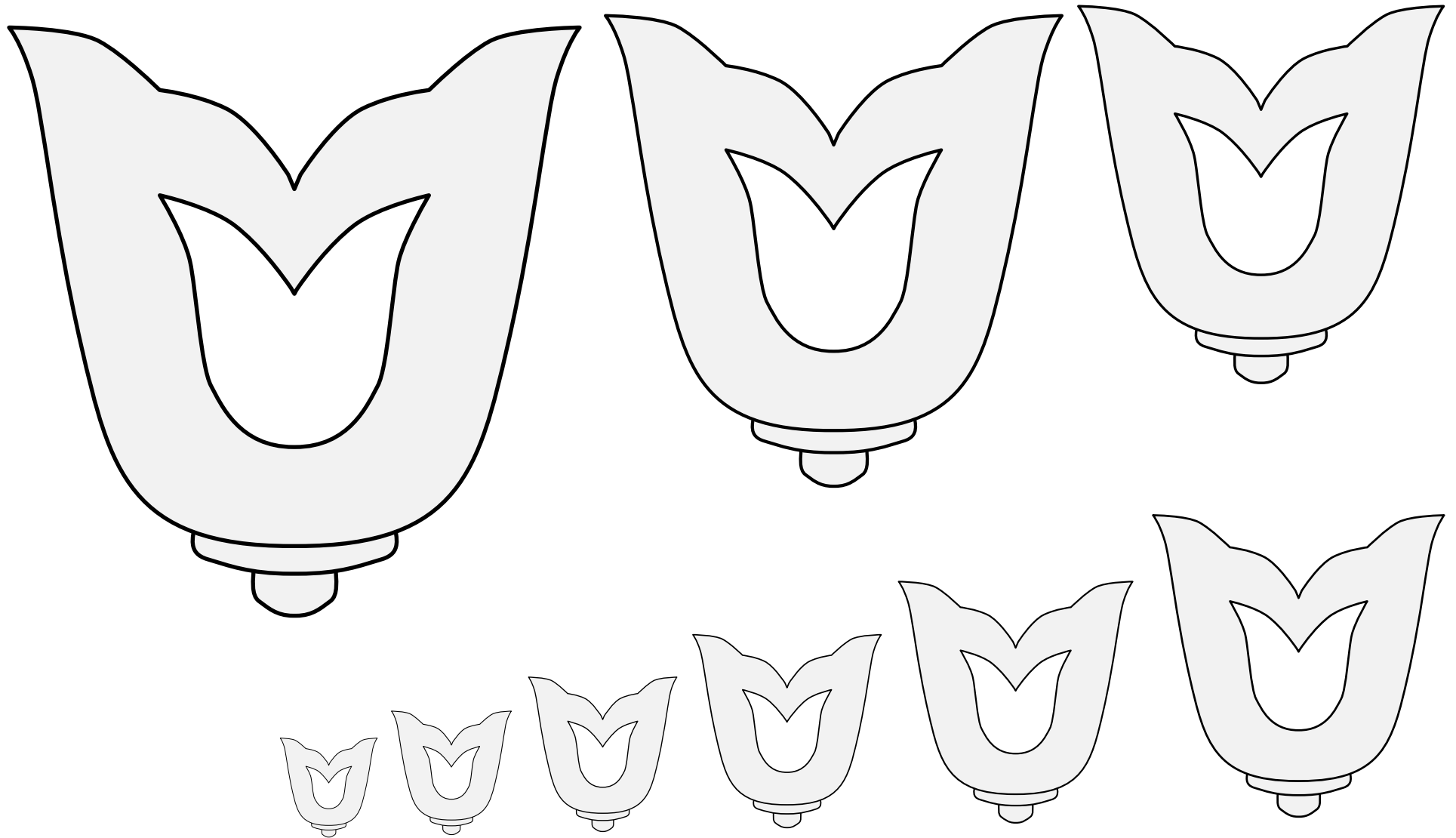

A metal end-cap used to reinforce the end of a scabbard.

Default orientation: point to base. No default coloration.

Source: Banners, Standards, and Badges. Artist: Thomas Willement.  
(Banner of de la Warr, p. 184.)

Crampet (4) 21.88

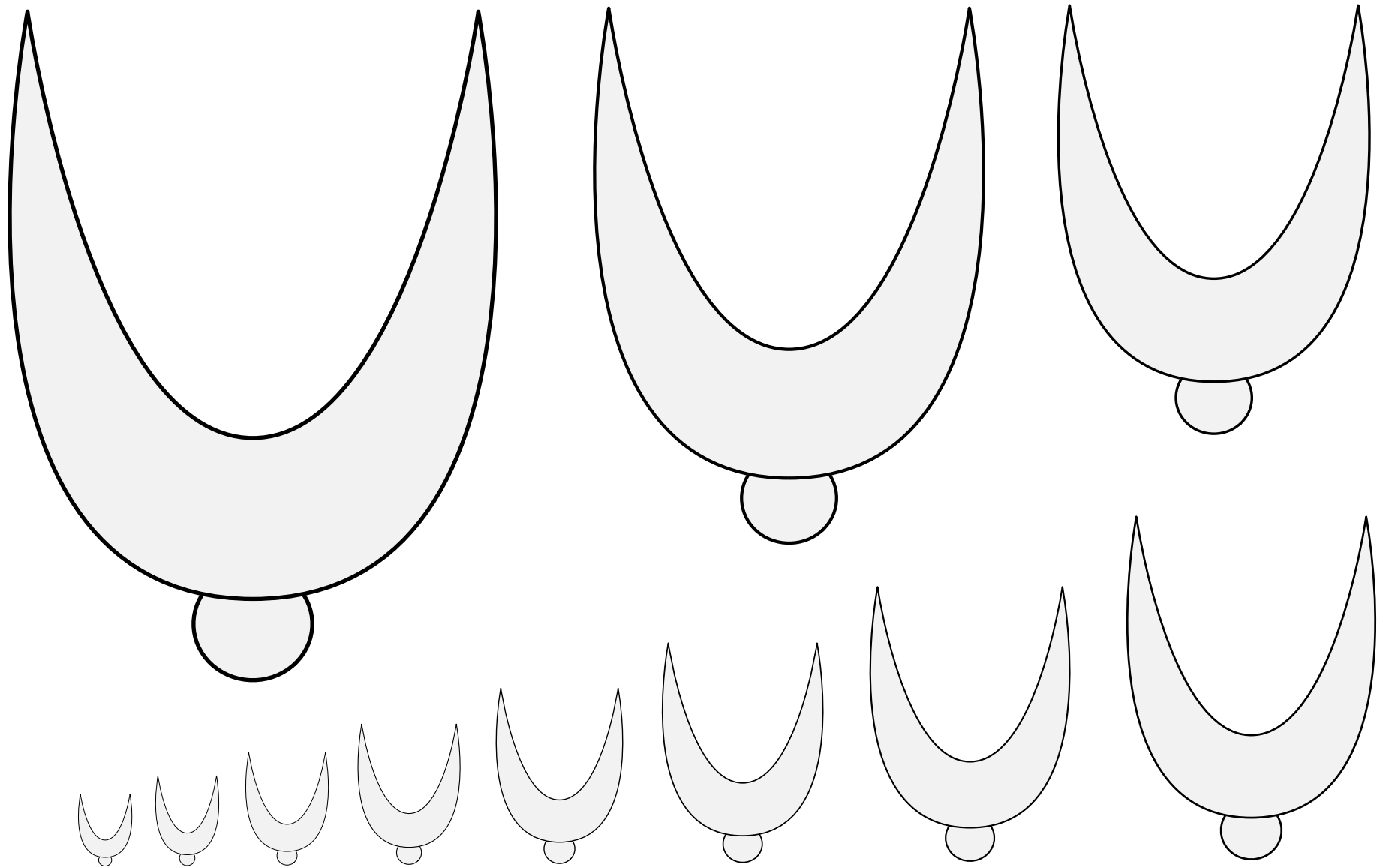

A metal end-cap used to reinforce the end of a scabbard.

Default orientation: point to base. No default coloration.

Source: Indice Armorial. Artist unknown.  
(Page 73, edition of 1635, s.v. Bouterole.)

Crampet (5) 21.89



A metal end-cap used to reinforce the end of a scabbard.  
Default orientation: point to base. No default coloration.  
Adapted from images of stone carvings in the chantry chapel of de la Warr.

**Crampet (6)** 21.90

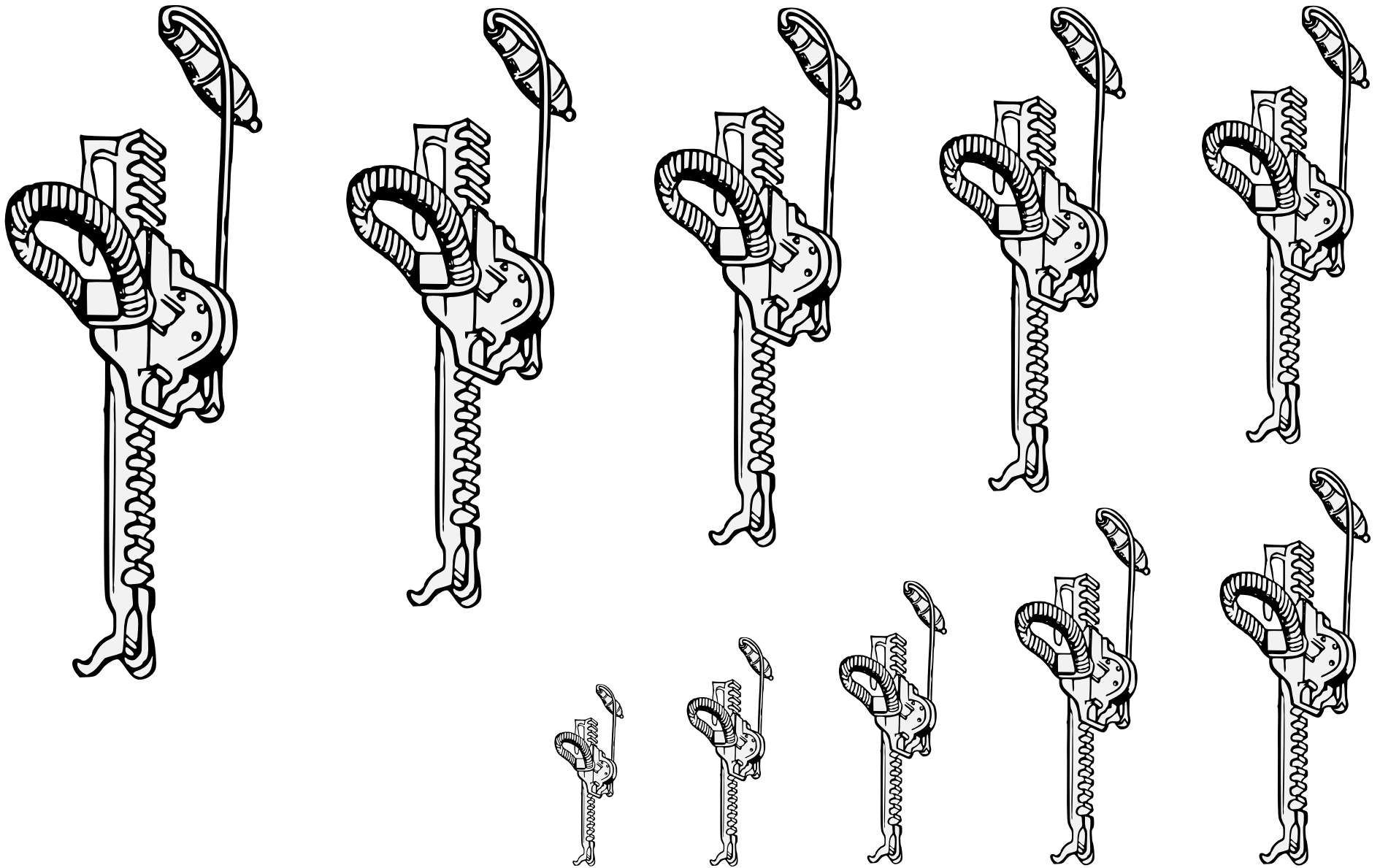

A geared mechanism used to span a crossbow.

No default orientation. No proper coloration.

Source: A Cyclopedia of Costume. Artist unknown. (Volume I, page 339.)

Cranequin 21.91

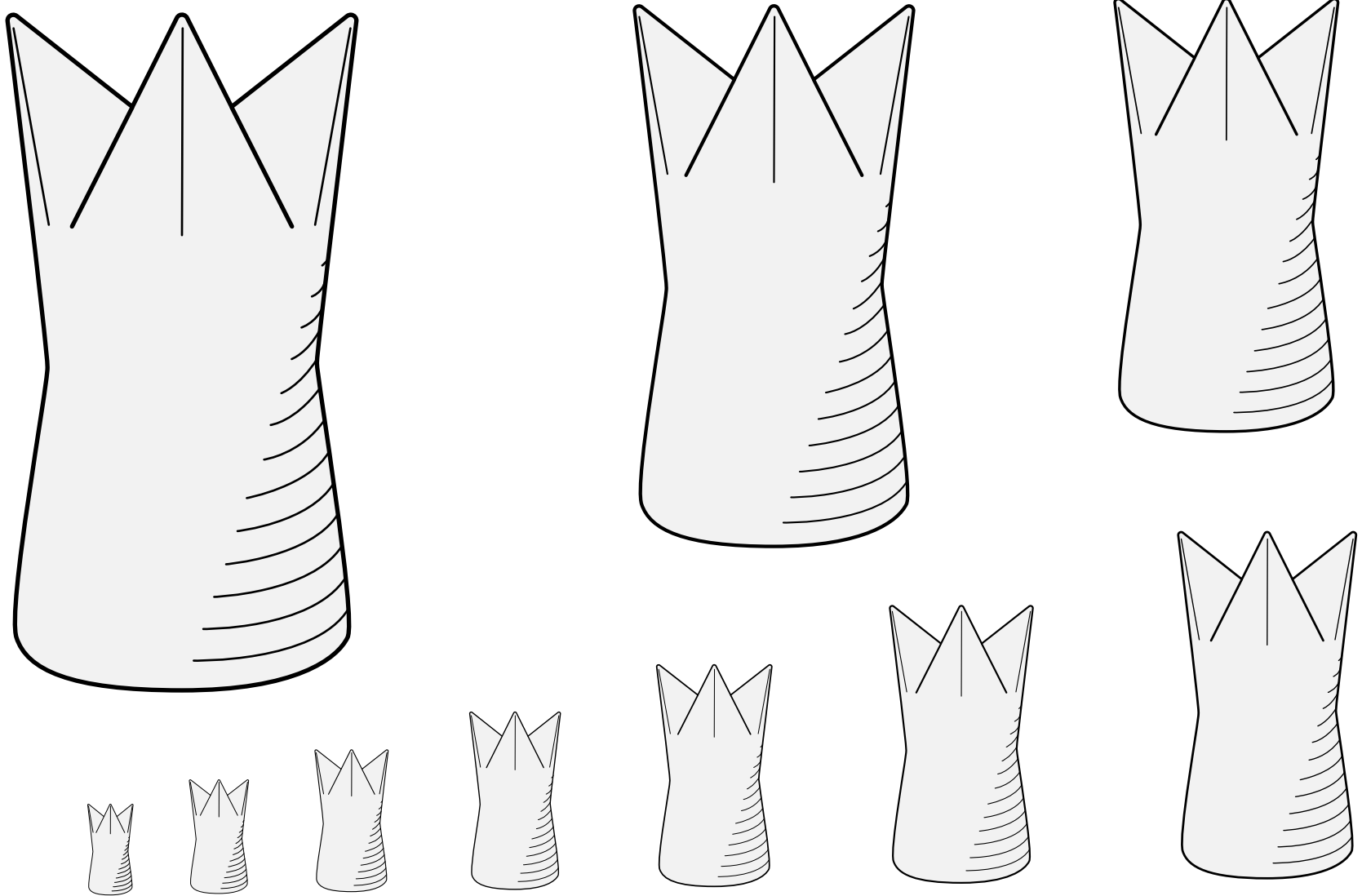

The head of a jousting spear with three blunted points, used in sport matches. Sometimes spelled "cronal."

This charge may be restricted, as the Feb 1987 LoAR ruled that an example submitted at that time overly resembled a crown.

Default orientation: points to chief.

Adapted from images of modern reproductions of period artifacts.

**Cronel (1)** 21.92



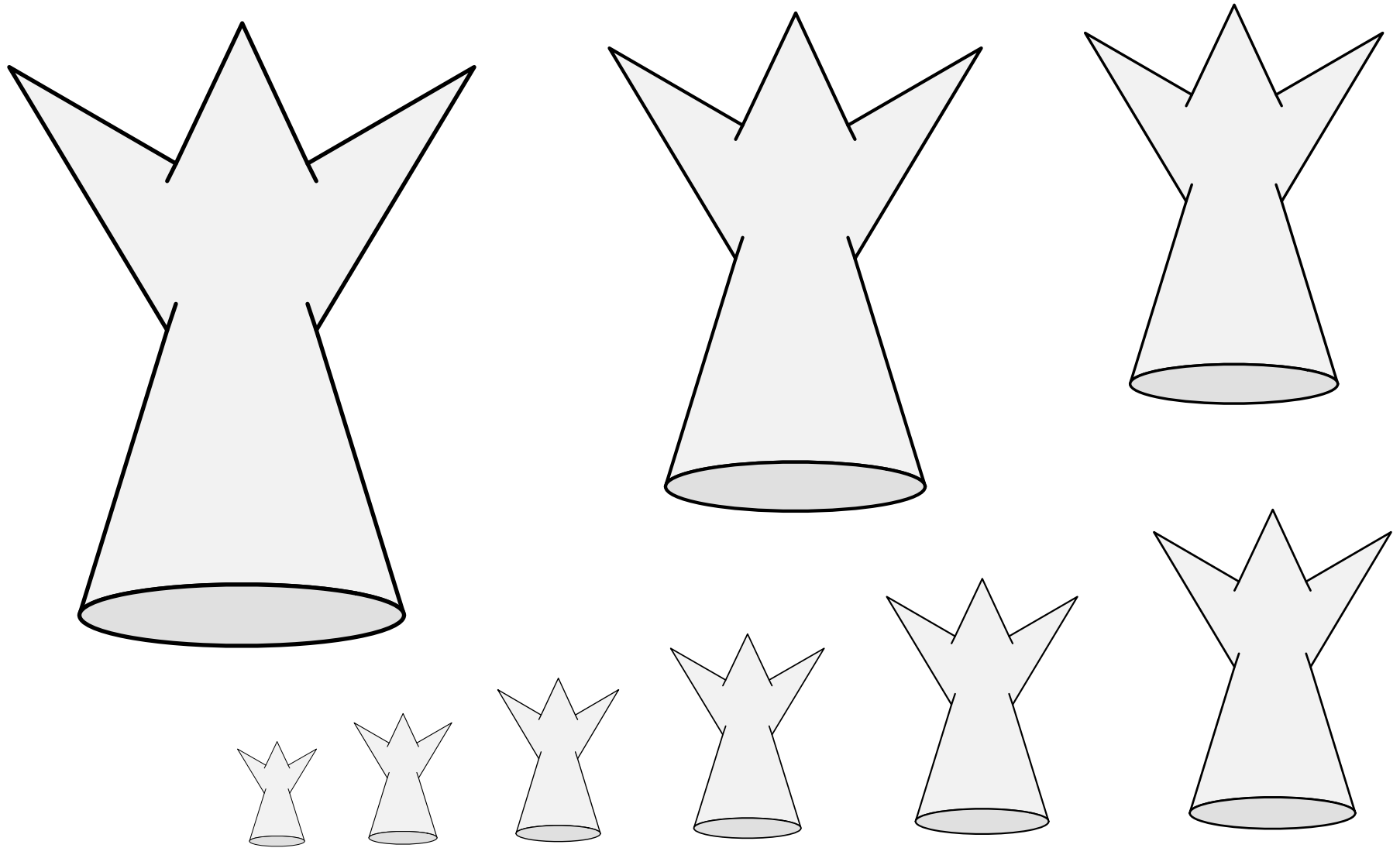

The head of a jousting spear with three blunted points, used in sport matches. Sometimes spelled "cronal."

This charge may be restricted, as the Feb 1987 LoAR ruled that an example submitted at that time overly resembled a crown.

Default orientation: points to chief.

Source: Wappenbuch der Arlberg-Bruderschaft. Artist: Vigil Raber. (Folio 14r.)

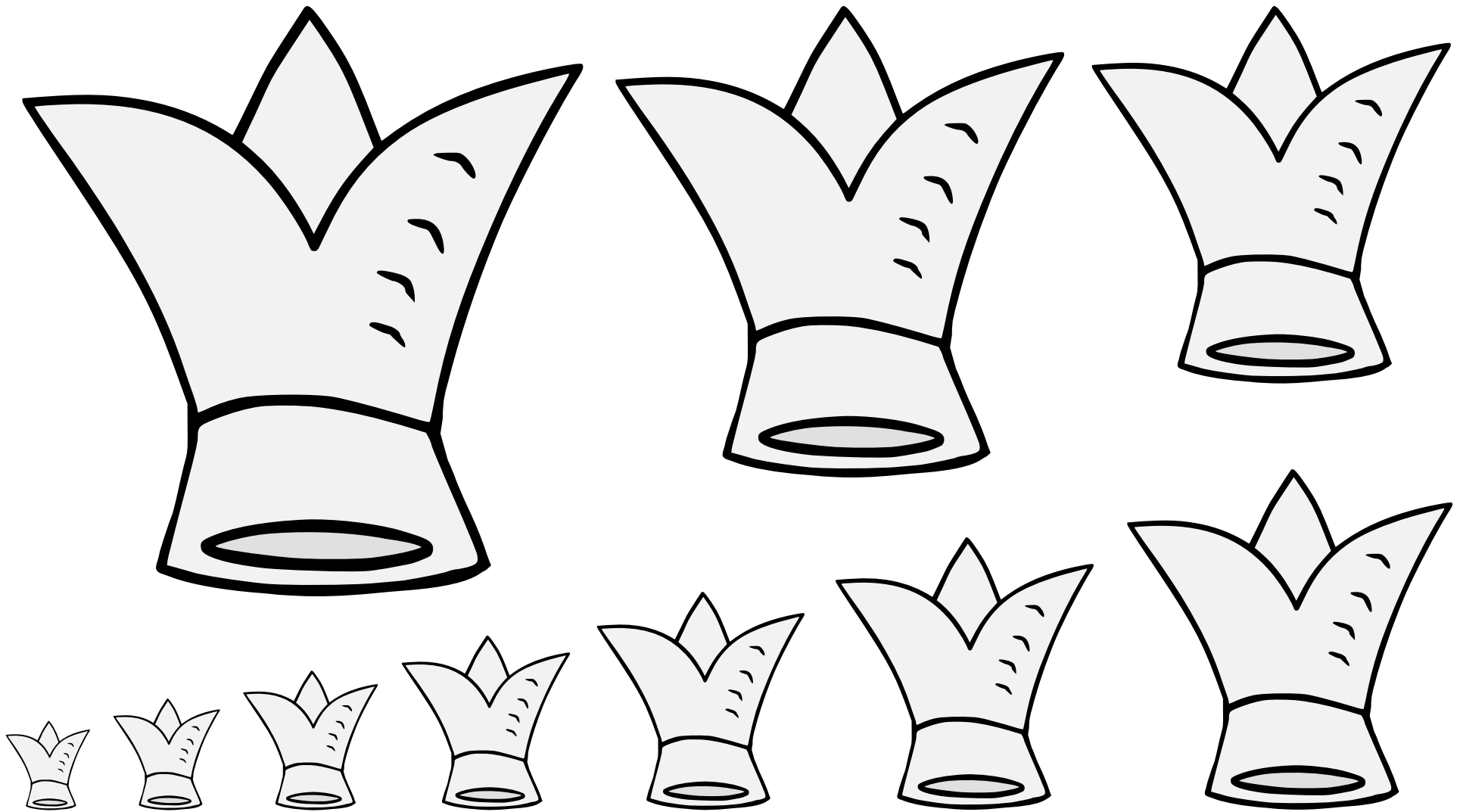

The head of a jousting spear with three blunted points, used in sport matches. Sometimes spelled "cronal."

This charge may be restricted, as the Feb 1987 LoAR ruled that an example submitted at that time overly resembled a crown.

Default orientation: points to chief.

Source: Confréries de la Cour Amoureuse. Artist unknown.

Adapted by Jessimond of Emerickeskepe. (Folio 35.)

Cronel (3) 21.94

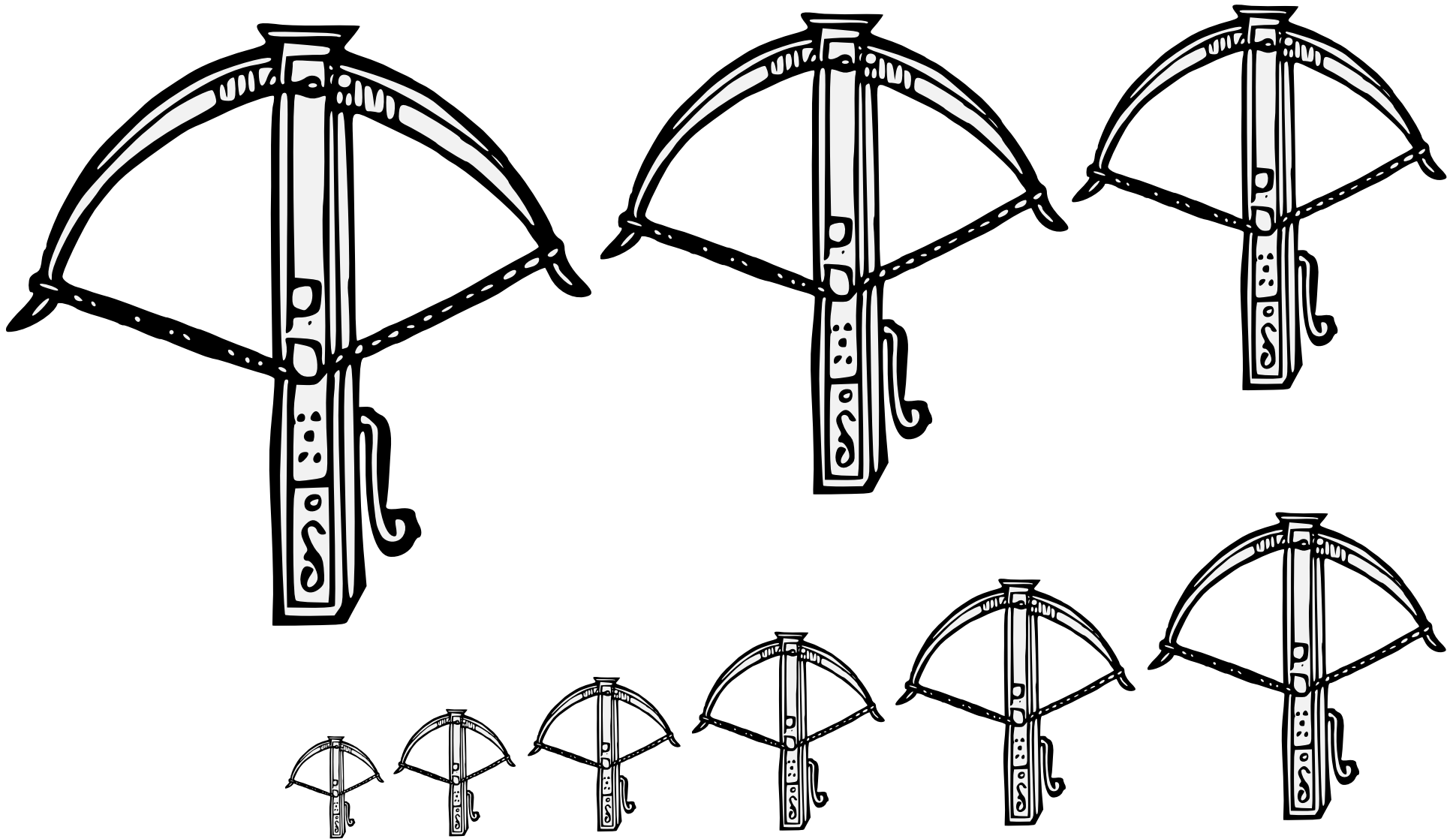

A bow attached to a stock that holds the string until a trigger is pulled.

Default orientation: pointing to chief. No proper coloration.

Source: Workes of Armorie. Artist: John Bossewell.

Crossbow (1) 21.95

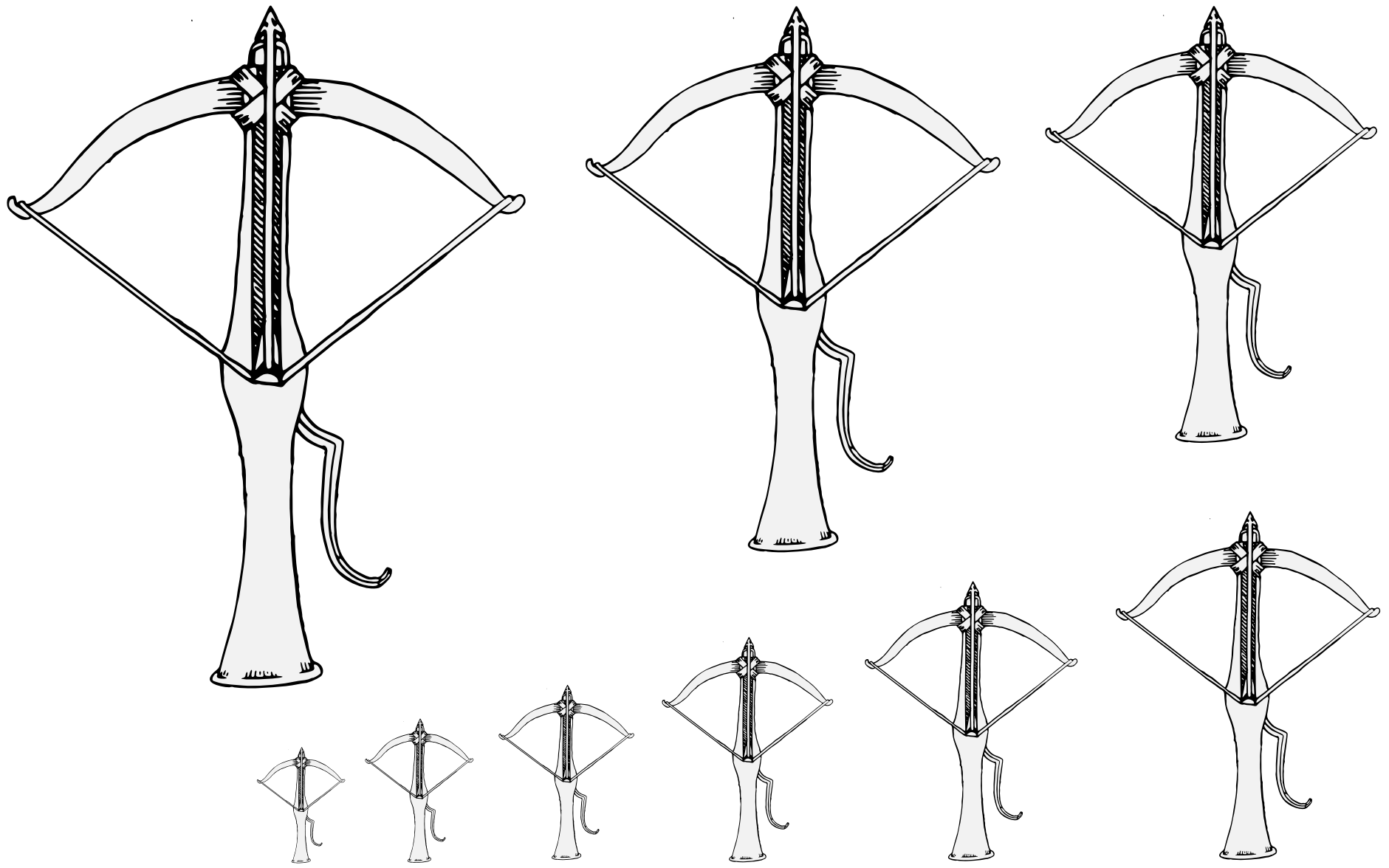

A bow attached to a stock that holds the string until a trigger is pulled.  
Default orientation: pointing to chief. No proper coloration.  
Source: Heraldic Templates. Artist: Torric inn Björn.

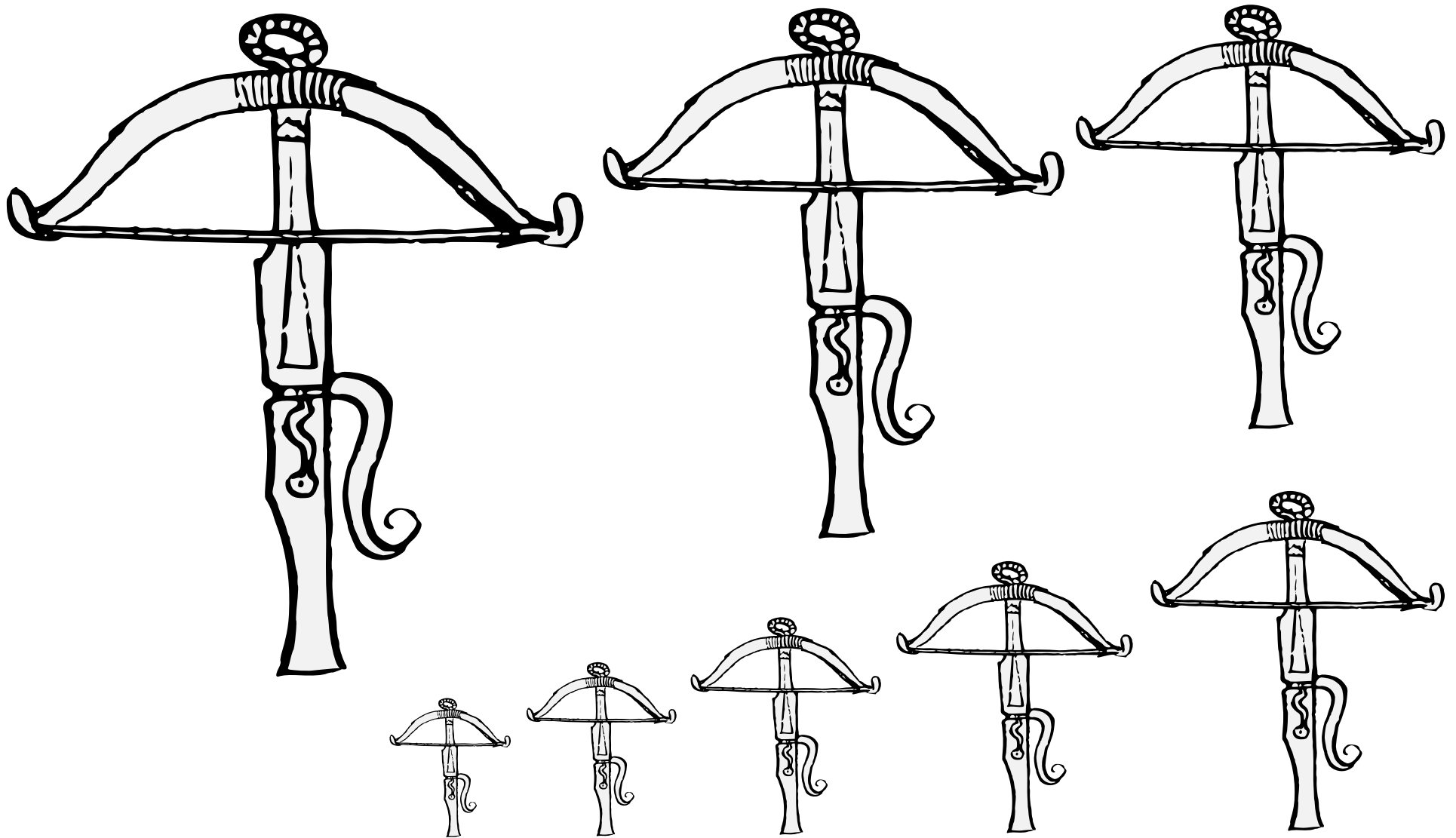

A bow attached to a stock that holds the string until a trigger is pulled.

Default orientation: pointing to chief. No proper coloration.

Source: Aegidius Tschudi's Armorial. Artist unknown. Adapted by Iago ab Adam.

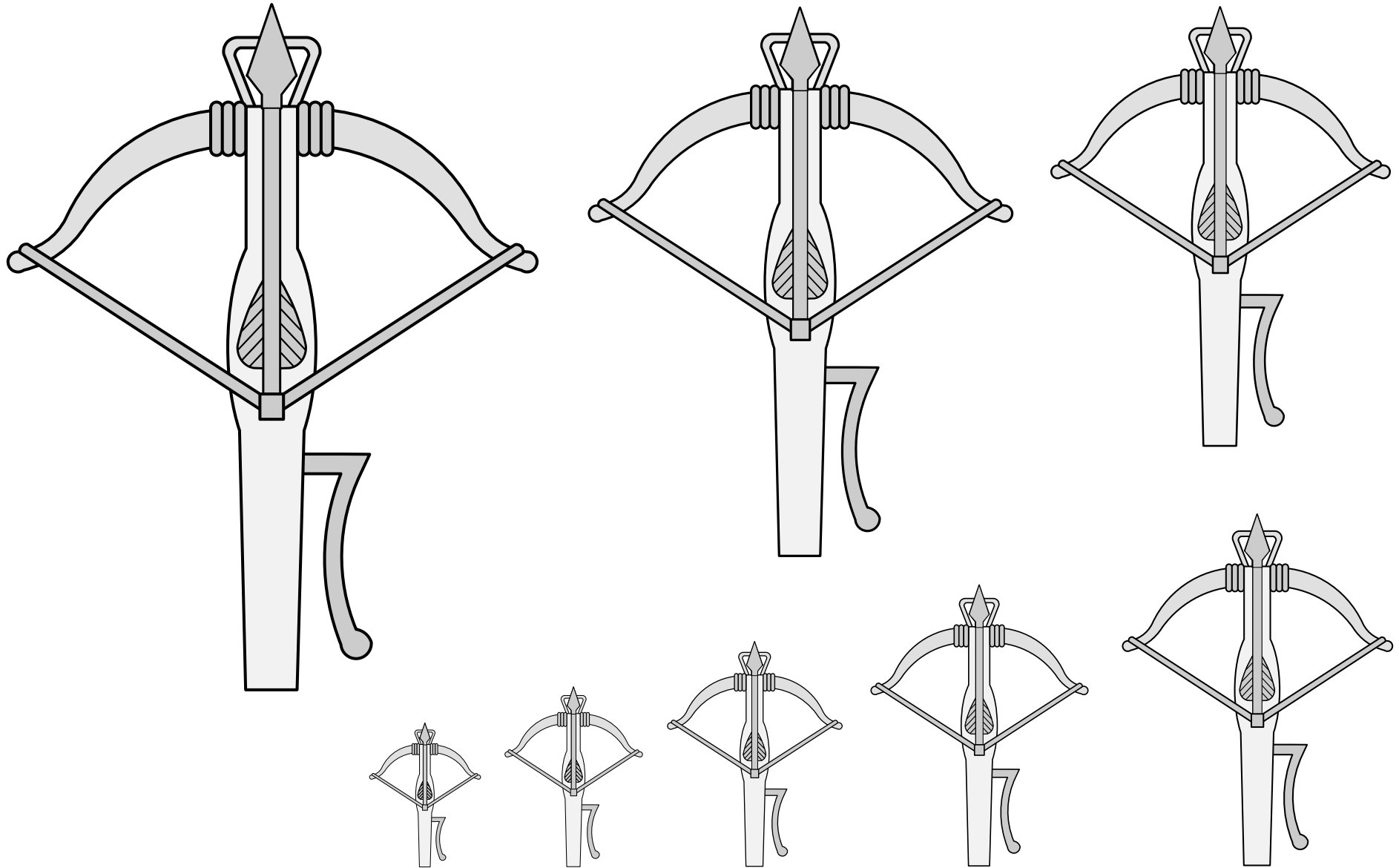

A bow attached to a stock that holds the string until a trigger is pulled.

Default orientation: pointing to chief. No proper coloration.

Source: Viking Answer Lady SVG Images For Heraldry. Artist: Gunnvôr silfráhr.

**Crossbow (4)** • 21.98

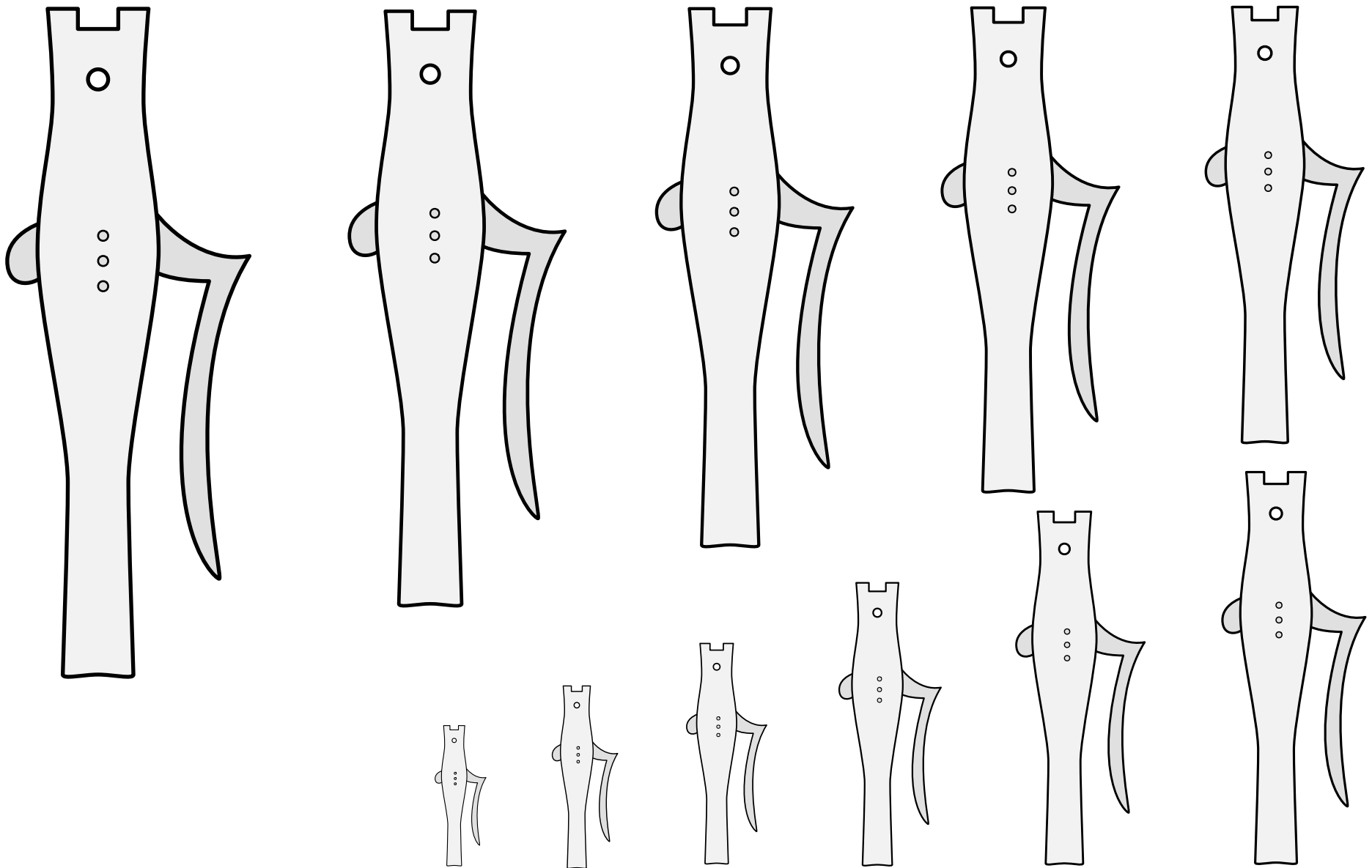

The rigid portion of a crossbow.

Default orientation: pointing to chief. No proper coloration.

Source: Wappenbuch der Arlberg-Bruderschaft.  
Artist: Vigil Raber. (Page 267.)

**Crossbow Stock (1)** 21.99

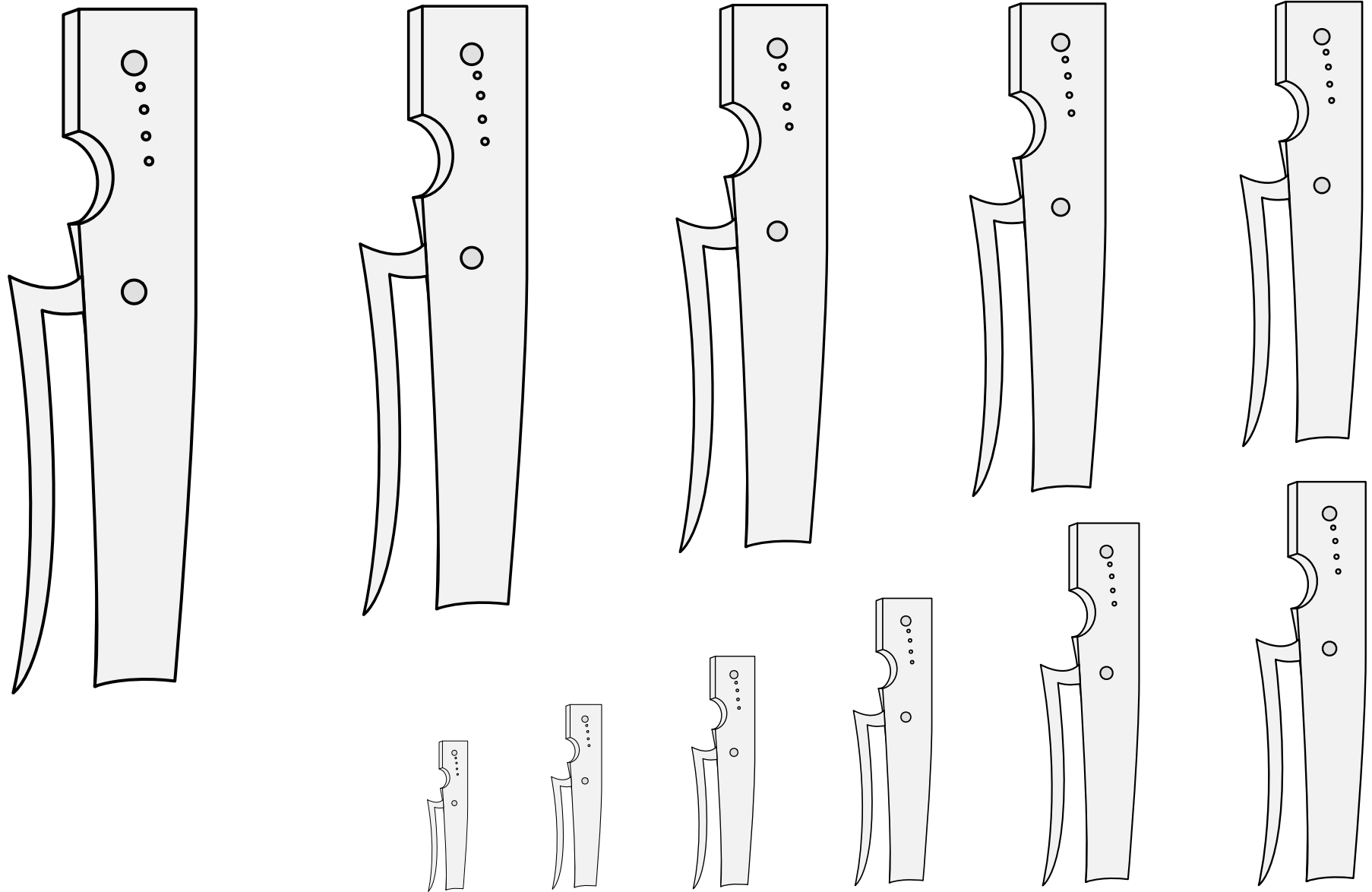

The rigid portion of a crossbow.

Default orientation: pointing to chief. No proper coloration.

Source: Wappenbuch der Arlberg-Bruderschaft.  
Artist: Vigil Raber. (Folio 379.)

**Crossbow Stock (2)** 21.100



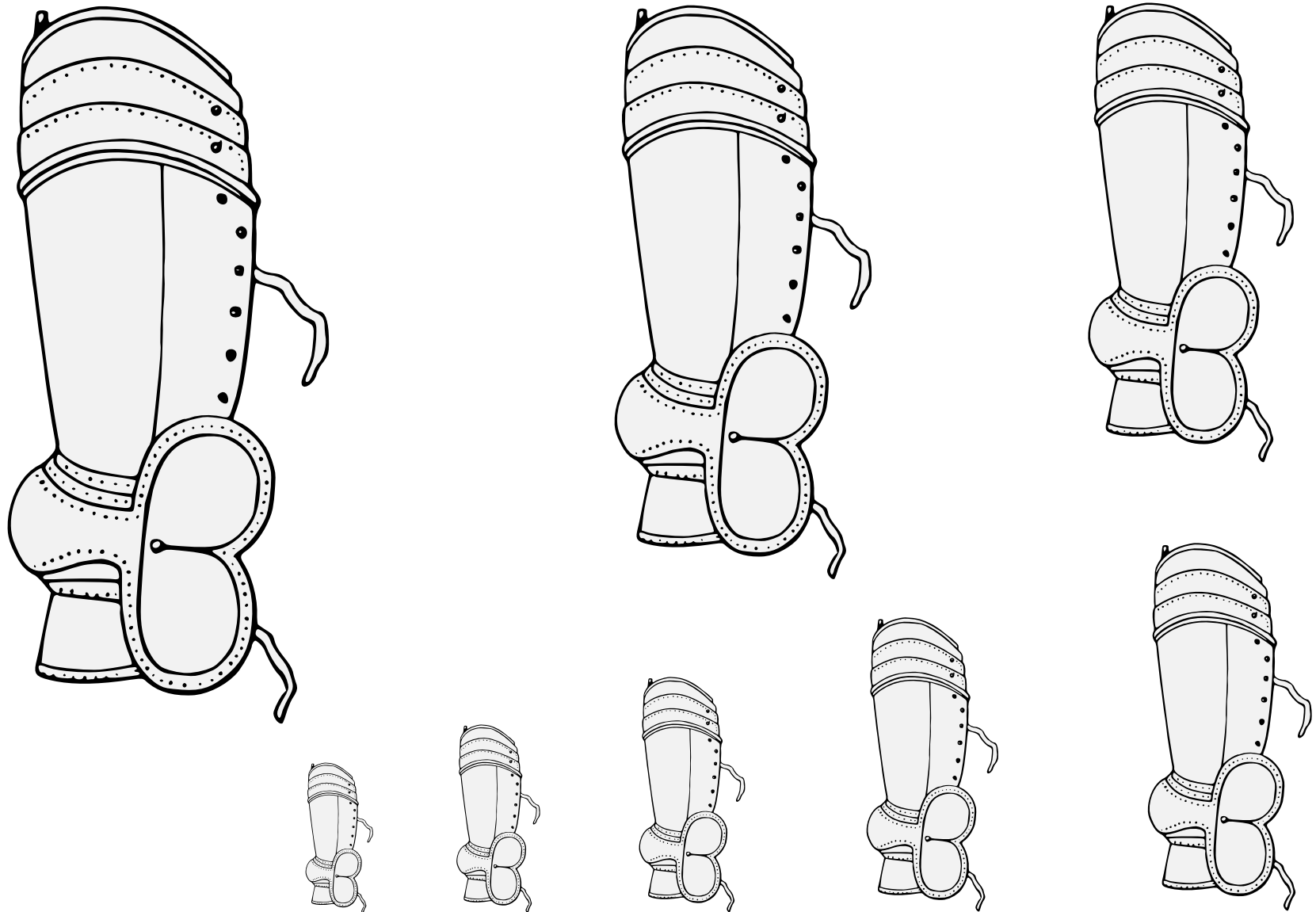

A piece of armor for the thigh and knee.

Default orientation: palewise. No proper coloration.

Source: A Cyclopedia of Costume. Artist unknown. (Volume I, page 157.)

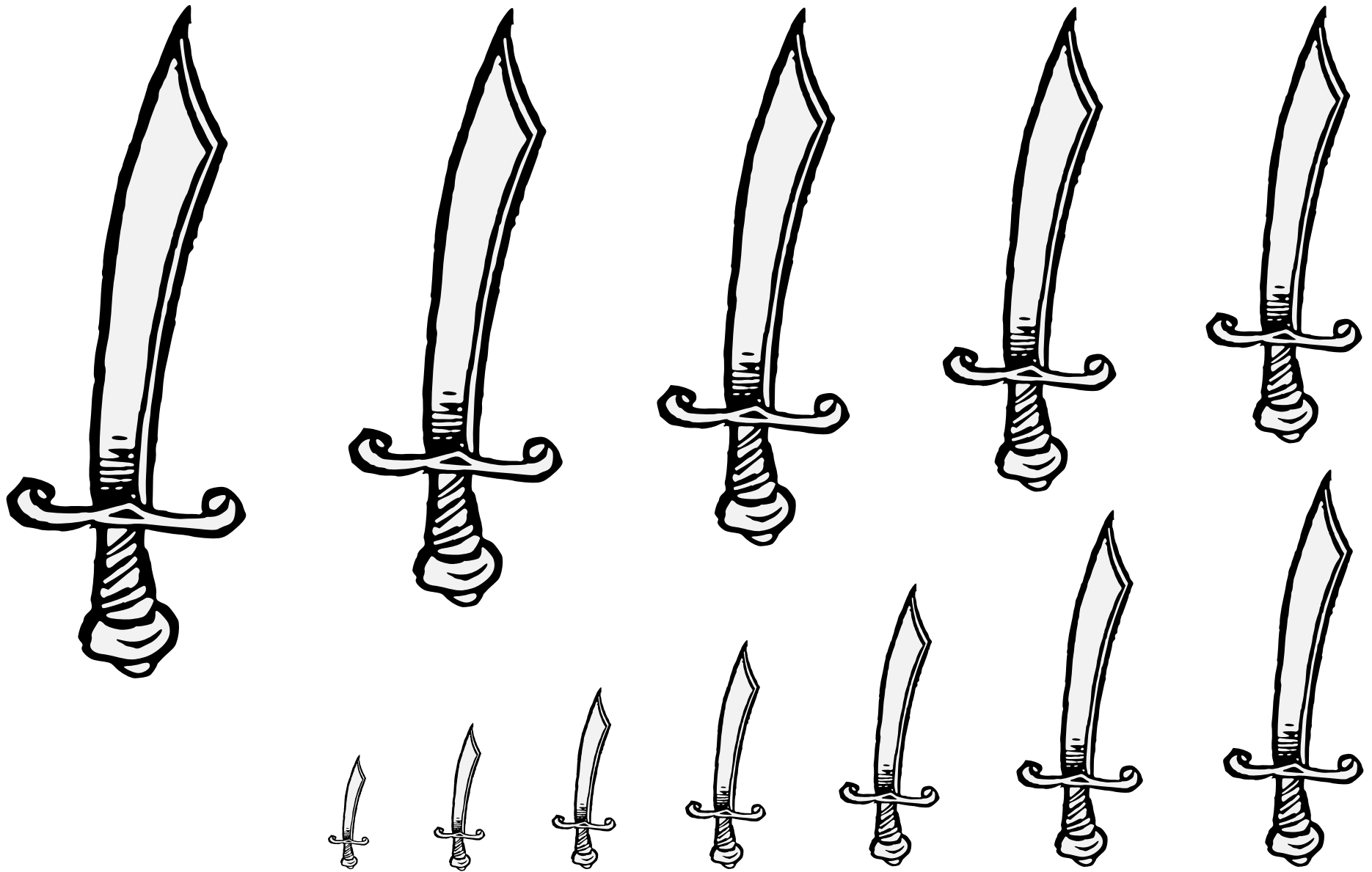

A metal tool for making holes in people.

Default orientation: point to chief. Proper coloration: blade argent, hilt Or.

Source: Guillim's Display of Heraldry. Artist unknown.

Cutlass 21.102

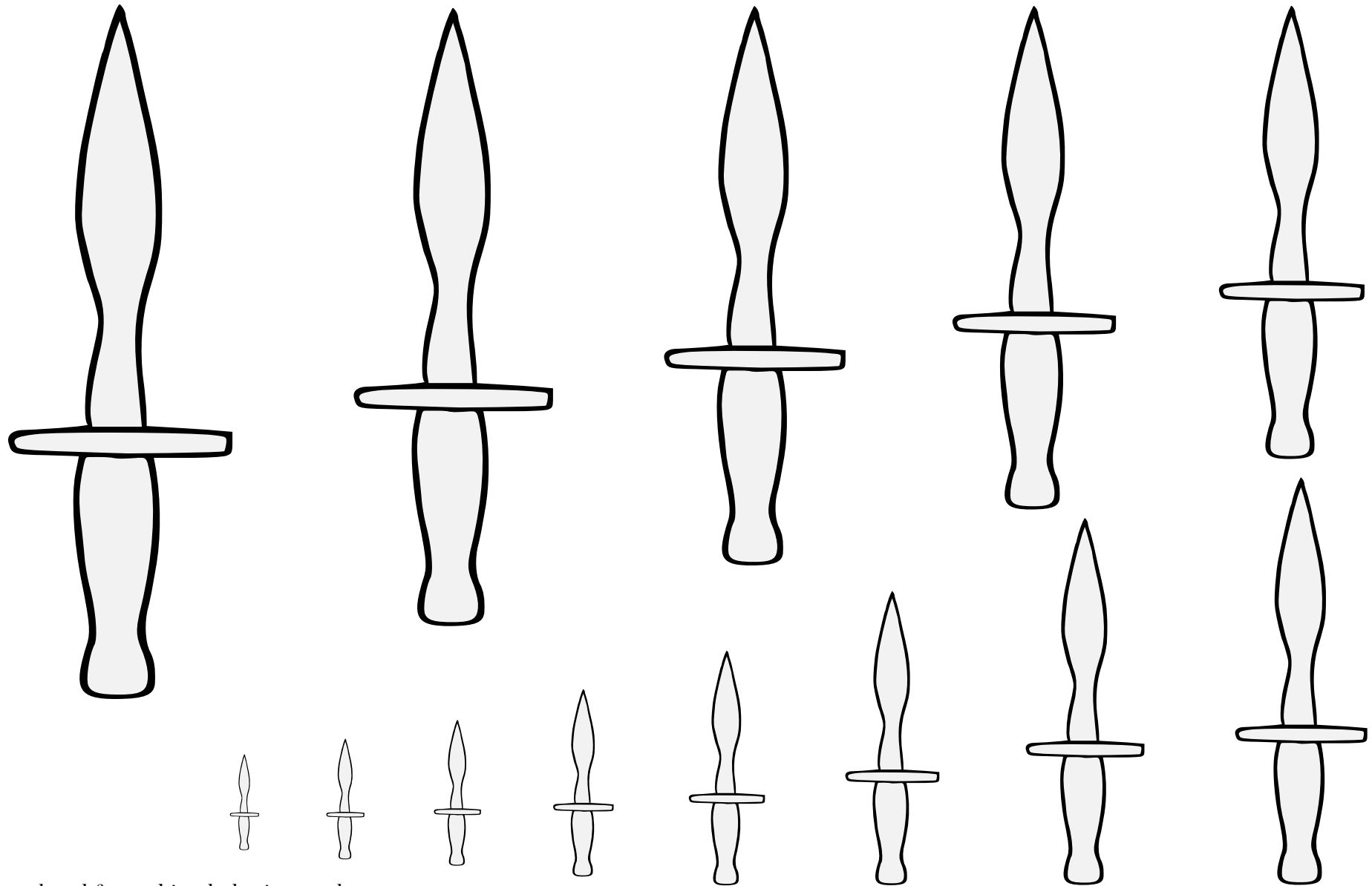

A metal tool for making holes in people.

Default orientation: point to chief. Proper coloration: blade argent, hilt Or.

This is not a period depiction of a dagger, and is considered a Step From Core Practice (SFCP).

Source: Pennsic Traceable Art. Artist unknown.

Dagger (1) 21.103

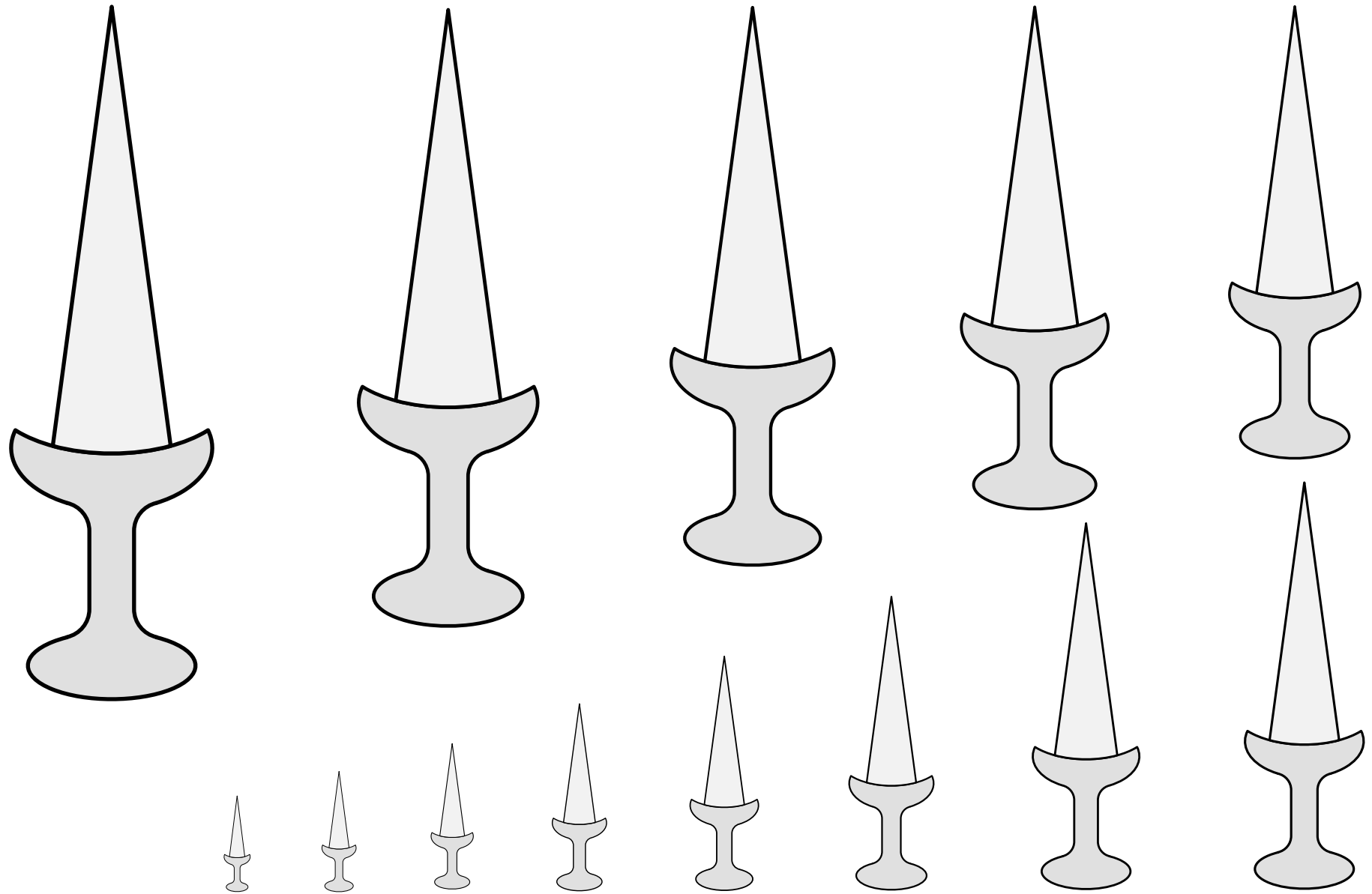

A metal tool for making holes in people.

Default orientation: point to chief. Proper coloration: blade argent, hilt Or.

Source: Zurich Roll. Artist unknown. Adapted by Mathghamhain Ua Ruadháin.

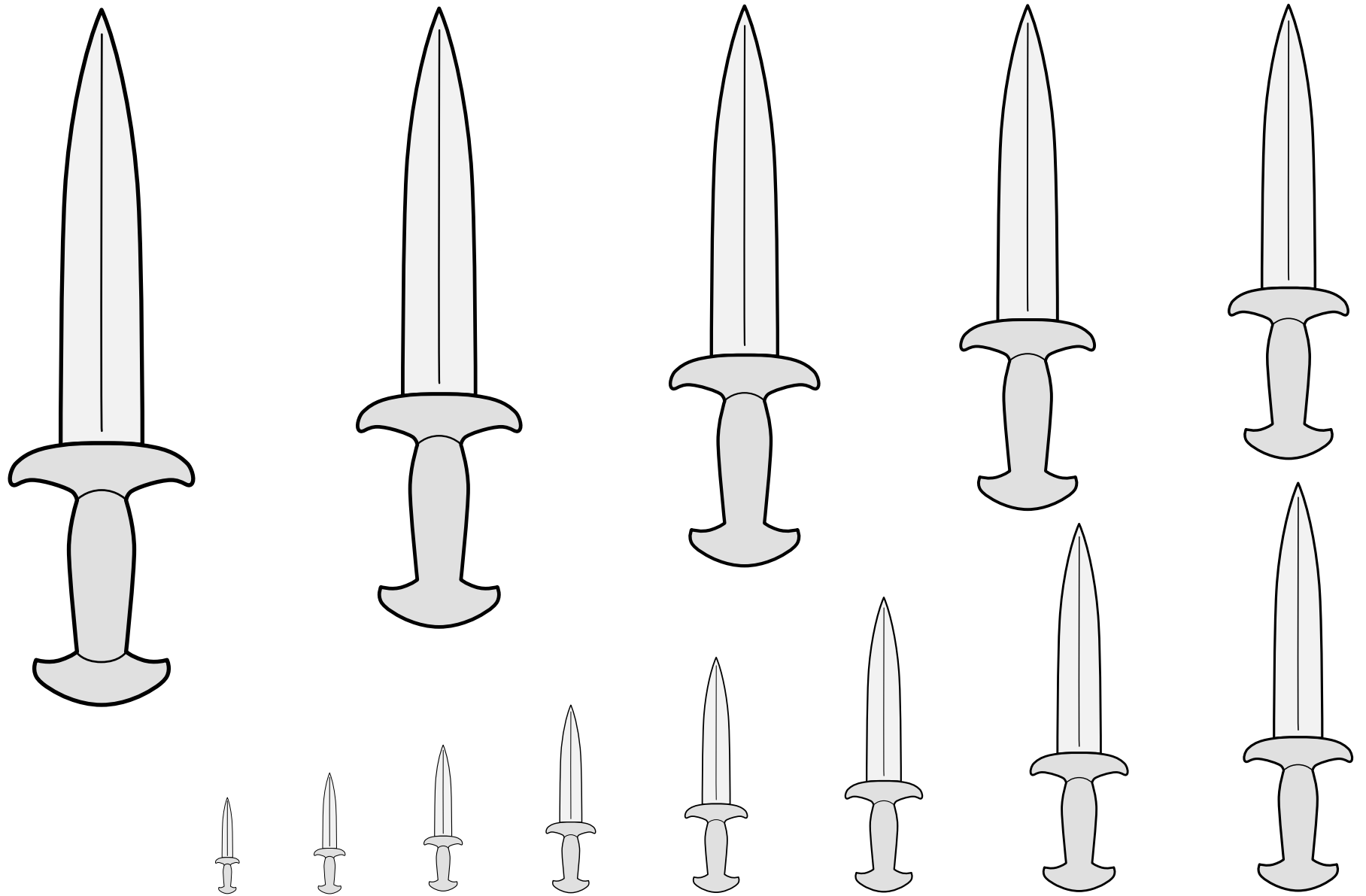

A metal tool for making holes in people.

Default orientation: point to chief. Proper coloration: blade argent, hilt Or.

Adapted from photos of a sixteenth-century Swiss “Holbein” dagger.

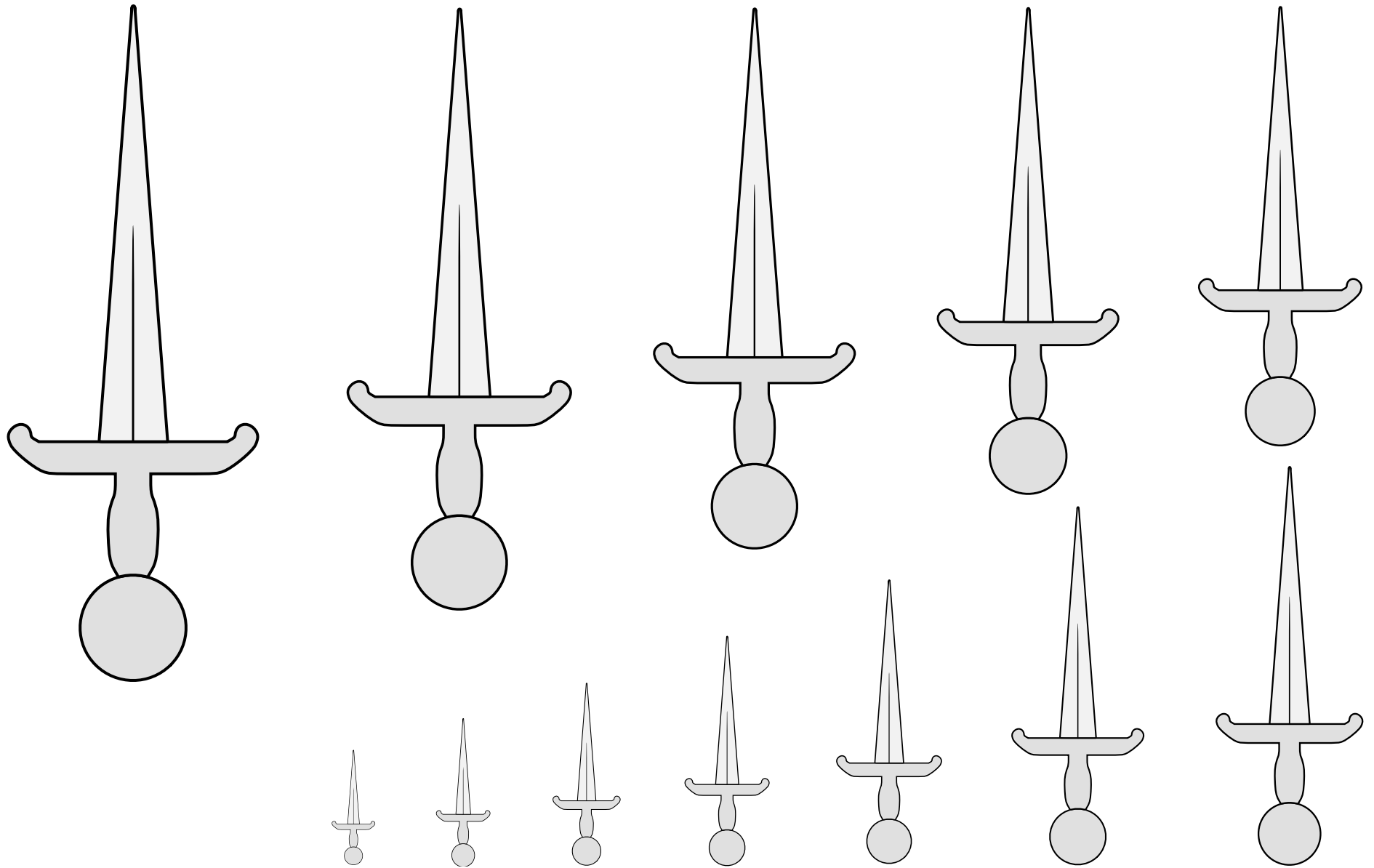

A metal tool for making holes in people.

Default orientation: point to chief. Proper coloration: blade argent, hilt Or.

Source: Insignia Anglica. Artist unknown. Adapted by Forveleth Dundee.

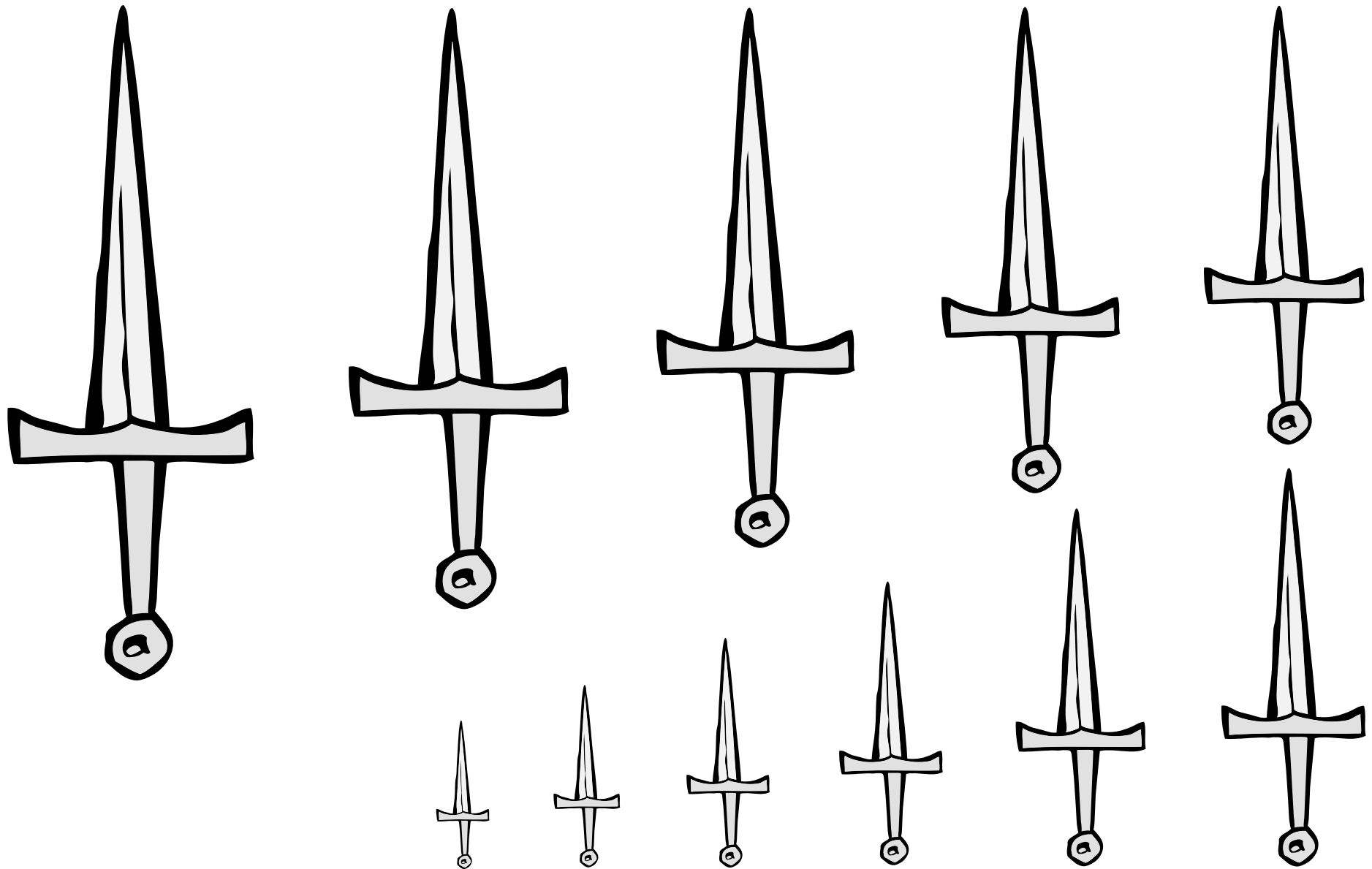

A metal tool for making holes in people.

Default orientation: point to chief. Proper coloration: blade argent, hilt Or.

Source: The Nobility of Venice. Artist unknown. (Folio 96v.)

Adapted by Saewynn aet Cnolle and Vémundr Syvursson.

Dagger (5) 21.107

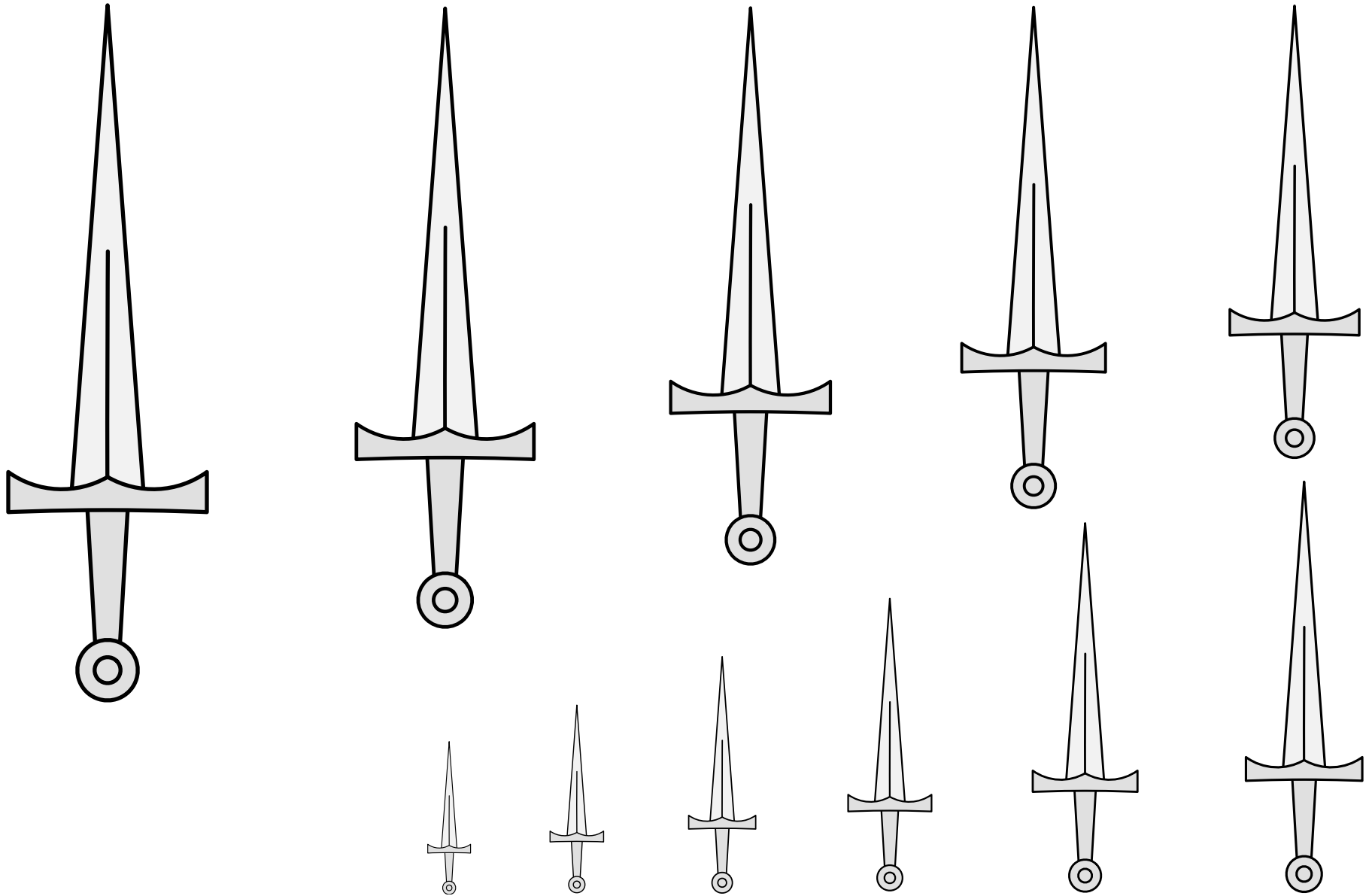

A metal tool for making holes in people.

Default orientation: point to chief. Proper coloration: blade argent, hilt Or.

Source: The Nobility of Venice. Artist unknown. (Folio 96v.)

Adapted by Saewynn aet Cnolle and Mathghamhain Ua Ruadháin.



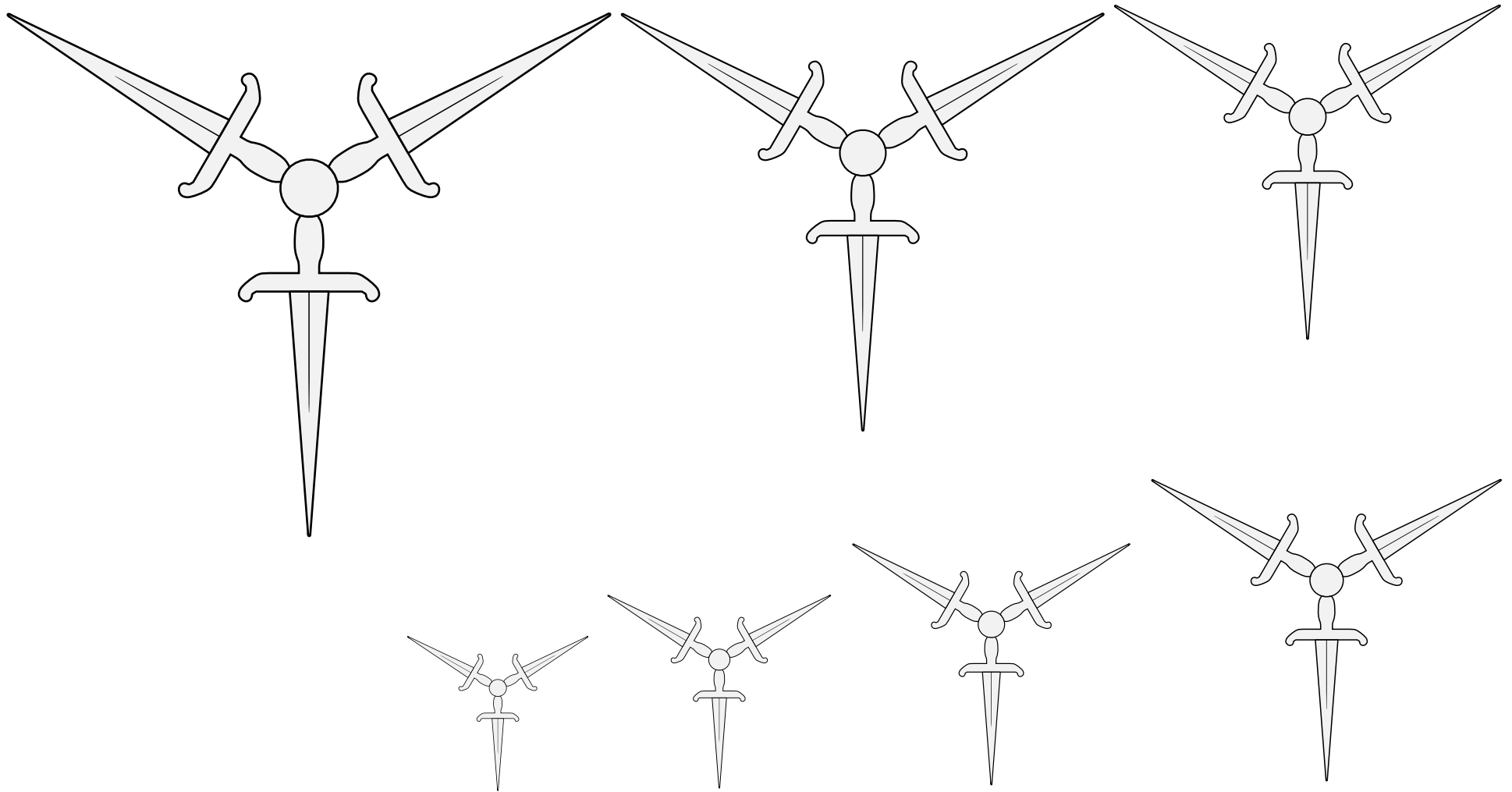

A metal tool for making holes in people.

Default orientation: point to chief. Proper coloration: blade argent, hilt Or.

Source: Insignia Anglica. Artist unknown. Adapted by Forveleth Dundee.

**Daggers, Three, Conjoined In Pall at the Hilts** 21.109

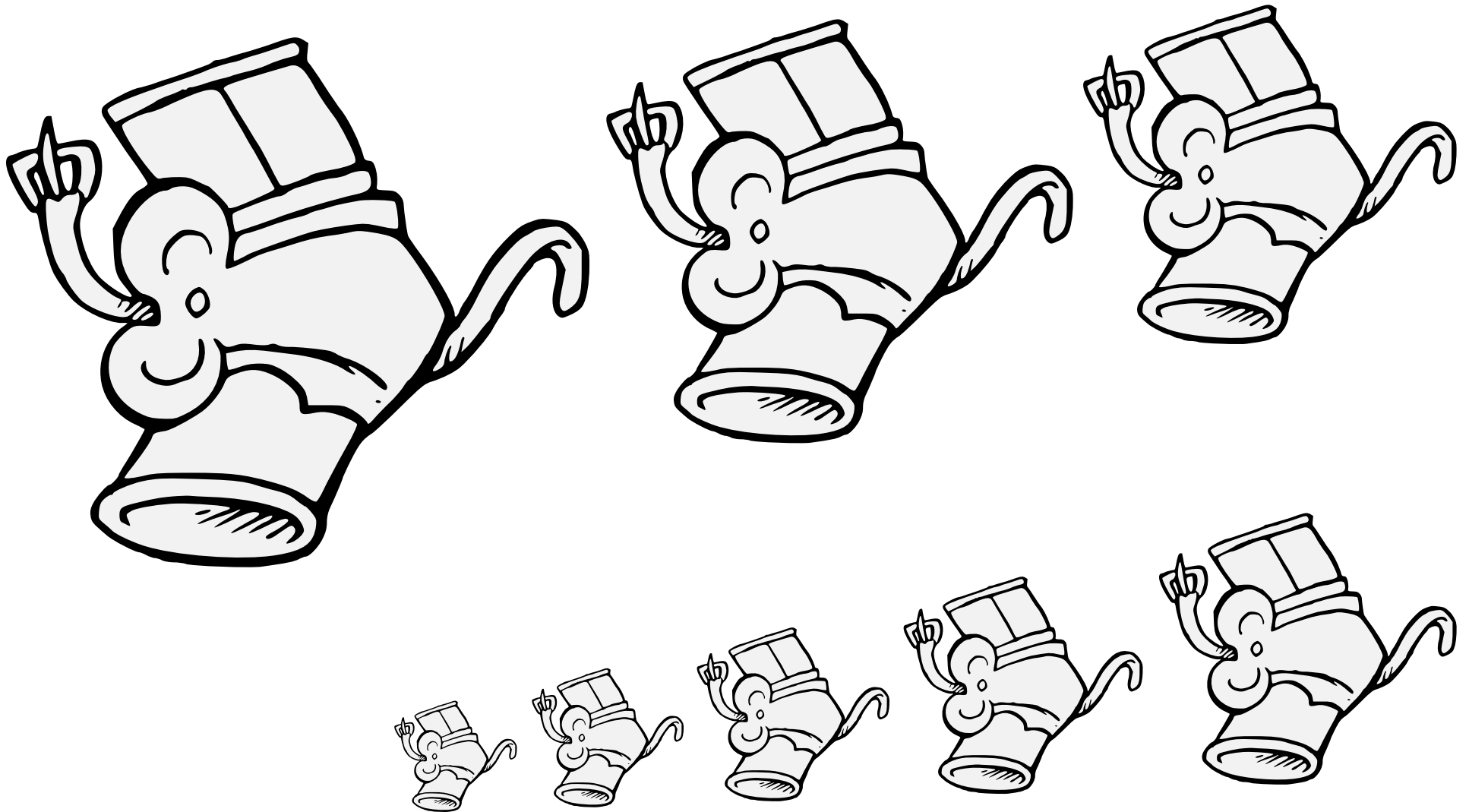

Protective equipment for the arm joint.

Default orientation: elbow to sinister. No proper coloration.

Source: Banners, Standards, and Badges. Artist: Thomas Willement.

Elbow Guard 21.110

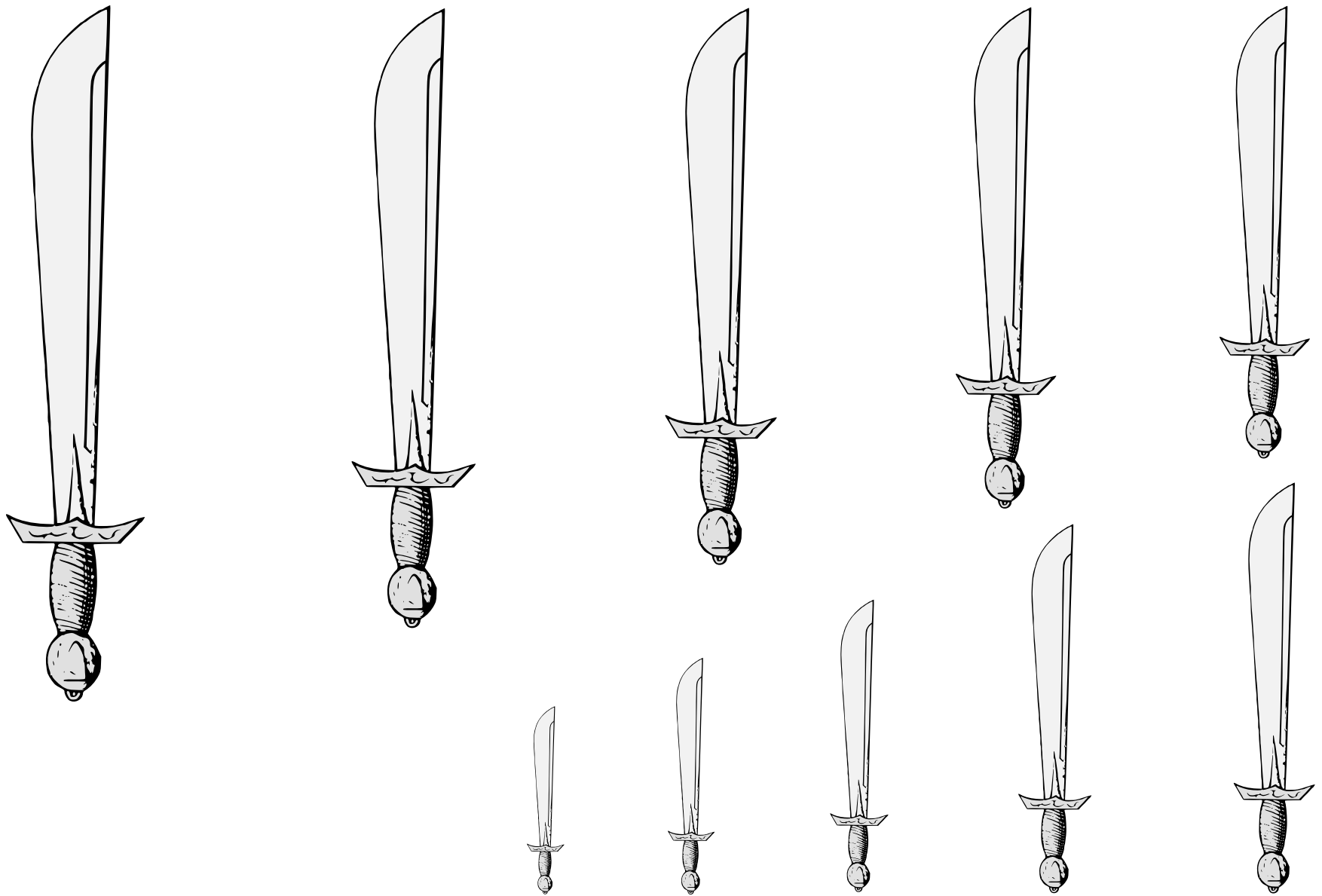

A sword with a curved cutting edge, reminiscent of a machete.

Default orientation: palewise, opening to chief. No proper coloration.

Source: A Cyclopedia of Costume. Artist unknown. (Volume I, page 184.)

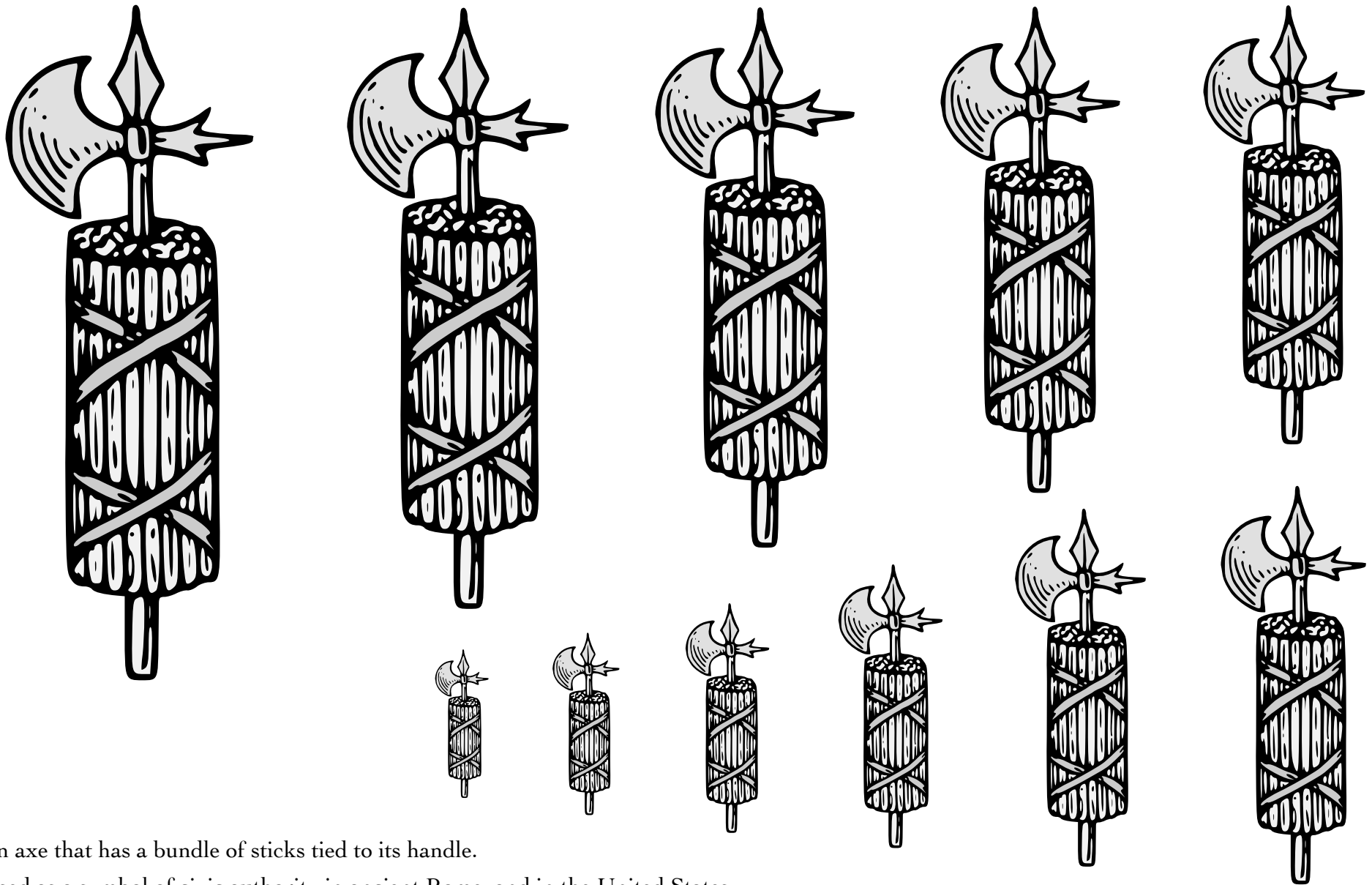

An axe that has a bundle of sticks tied to its handle.

Used as a symbol of civic authority in ancient Rome, and in the United States.

Potentially offensive due to its use as a symbol of Italian fascism during the twentieth century.

Default orientation: blade to chief, cutting to dexter. No proper coloration.

Source: A Complete Guide to Heraldry. Artist: Graham Johnston.

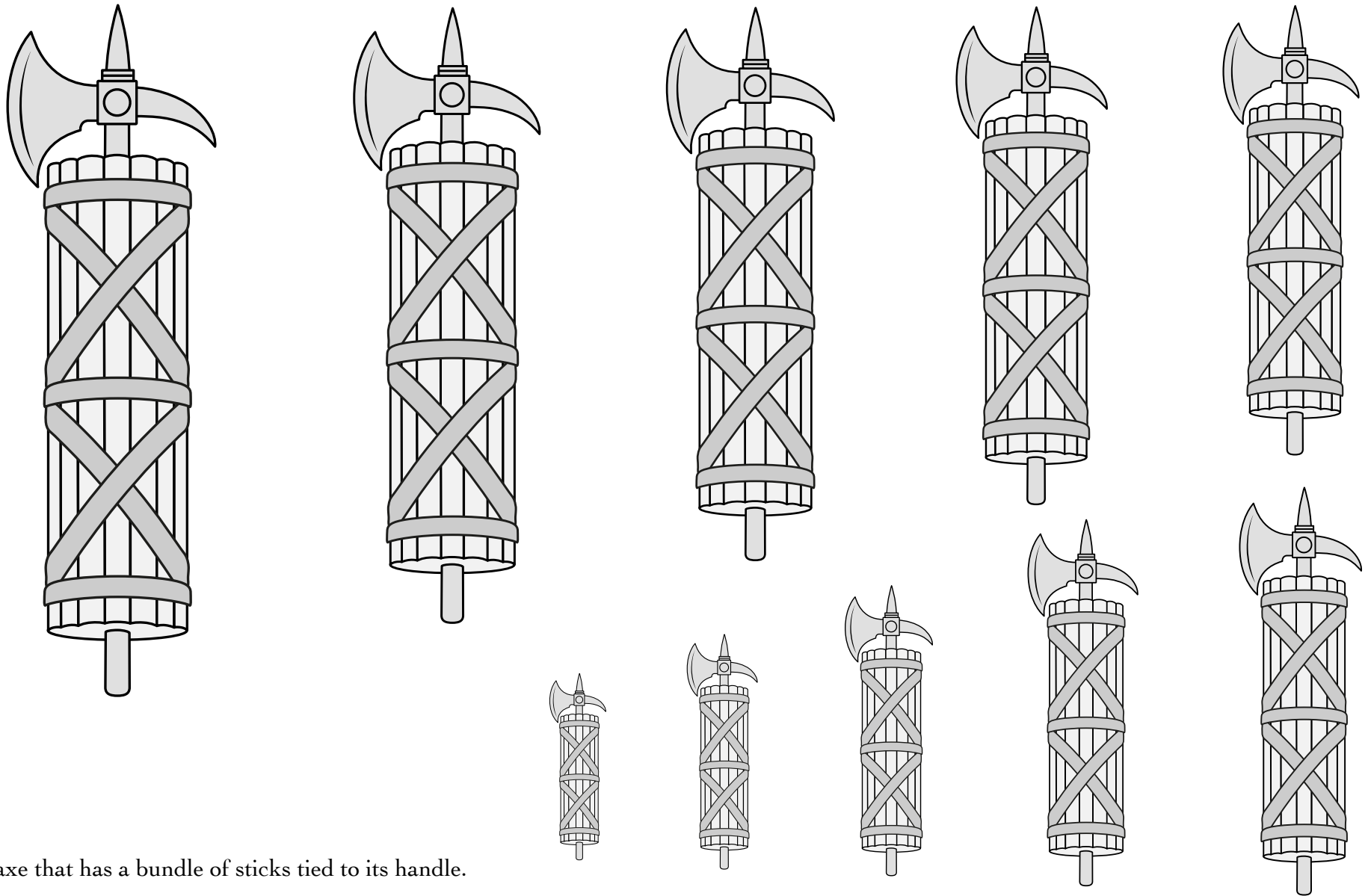

An axe that has a bundle of sticks tied to its handle.

Used as a symbol of civic authority in ancient Rome, and in the United States.

Potentially offensive due to its use as a symbol of Italian fascism during the twentieth century.

Default orientation: blade to chief, cutting to dexter. No proper coloration.

Source: WappenWiki. Artist: Joakim Spuller.

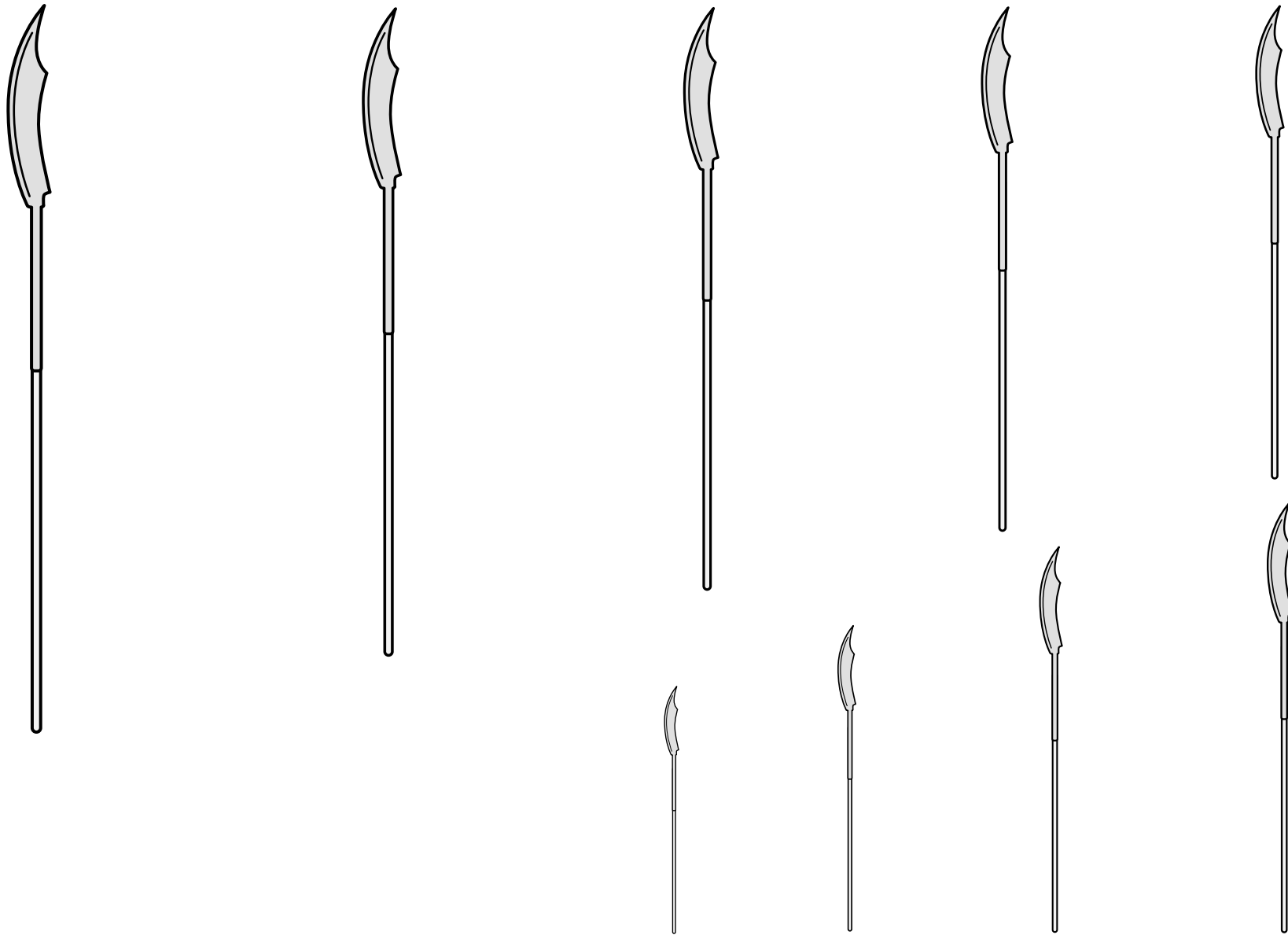

An agricultural implement mounted to a long haft for military purposes.  
Default orientation: point to chief. No proper coloration.  
Adapted from an image of fourteenth-century fauchards.

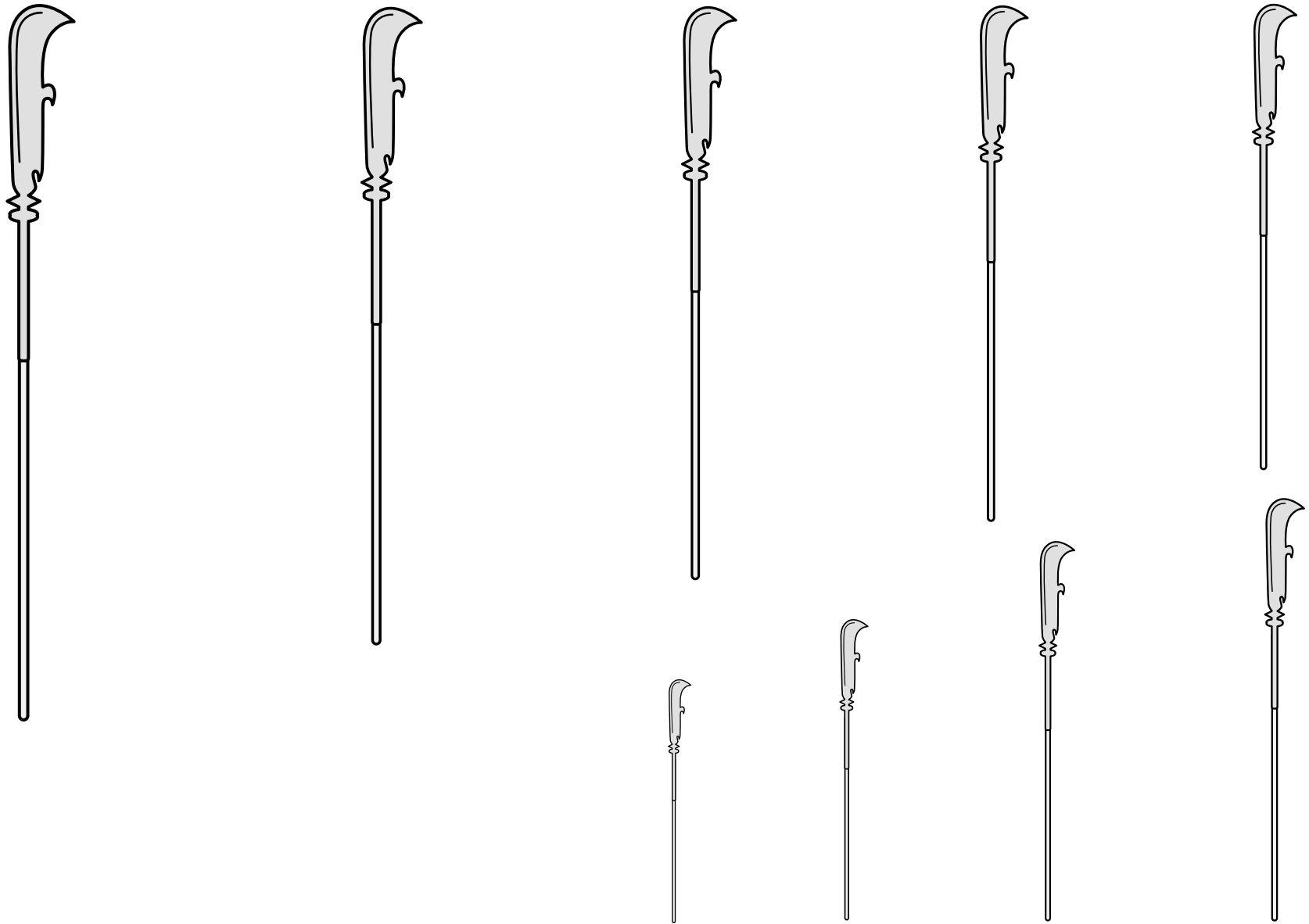

An agricultural implement mounted to a long haft for military purposes.  
Default orientation: point to chief. No proper coloration.  
Adapted from an image of sixteenth-century fauchards.

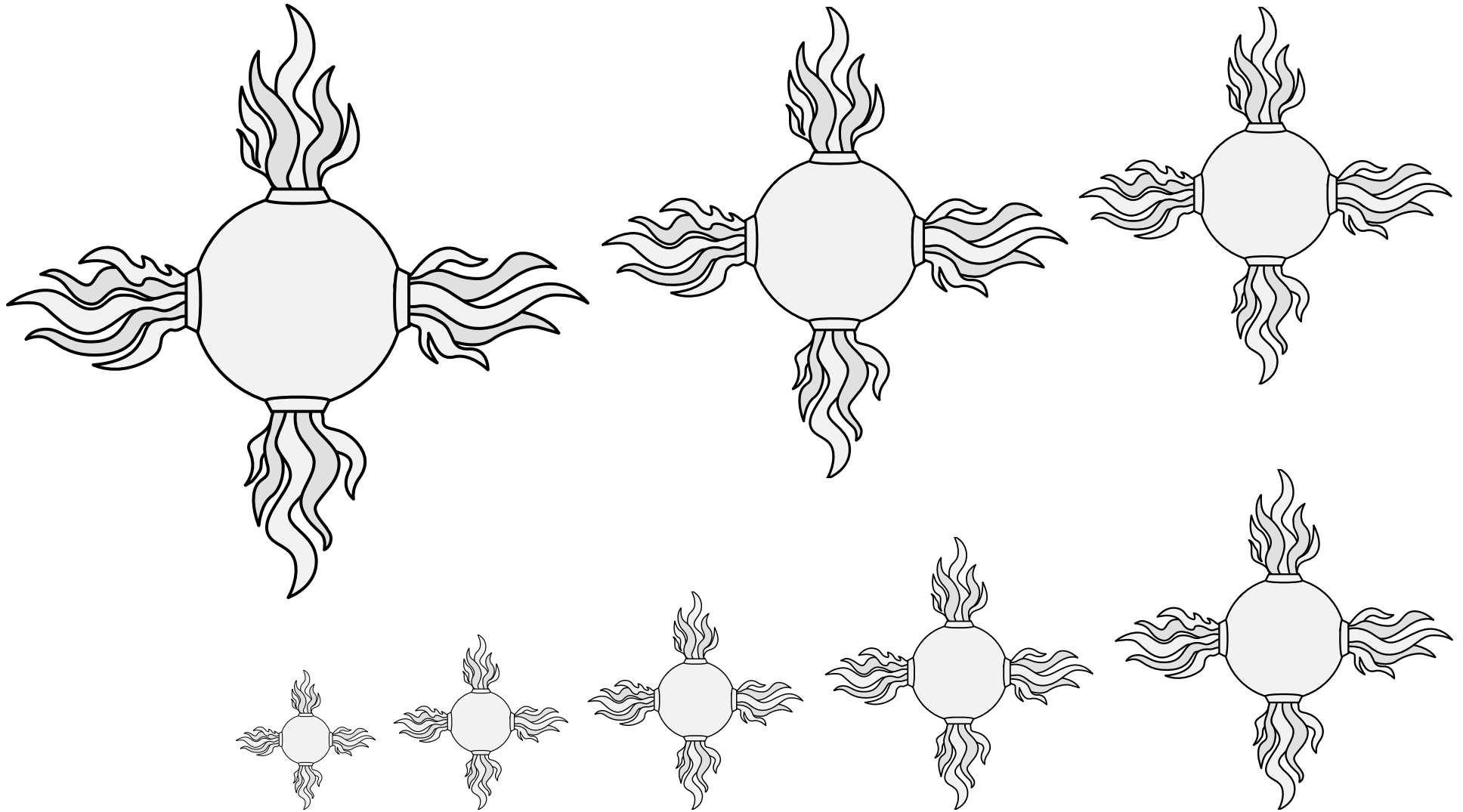

A flaming weapon, depicted as a metal ball spewing four flames in cross.



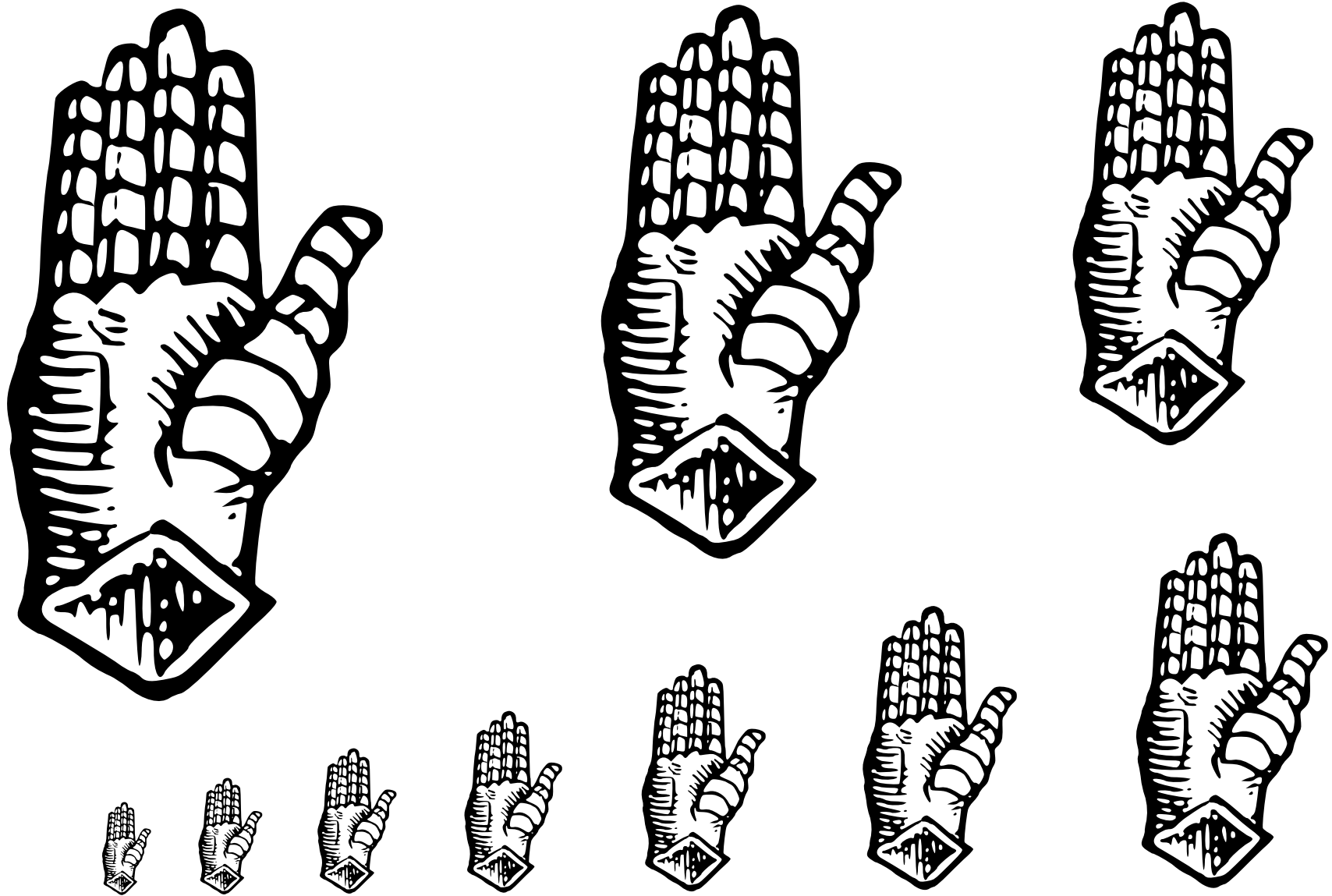

A piece of armor to cover the hand.

Default orientation: dexter hand apaumy.

Source: Guillim's Display of Heraldry. Artist unknown.

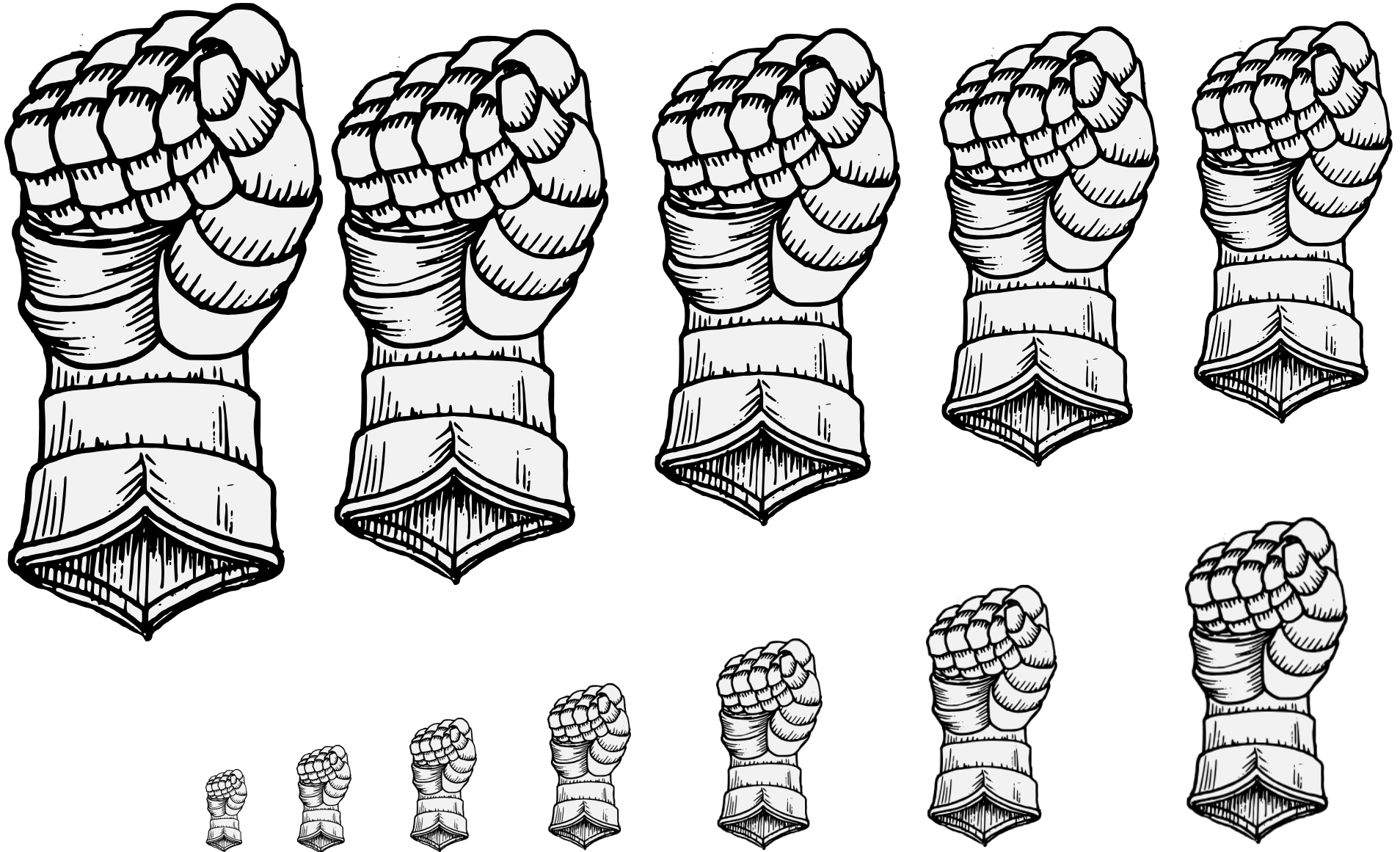

A piece of armor to cover the hand.

Default orientation: dexter hand apaumy.

The term “clenched” signifies that the hand is making a fist.

Source: Heraldic Templates. Artist: Torric inn Björn.

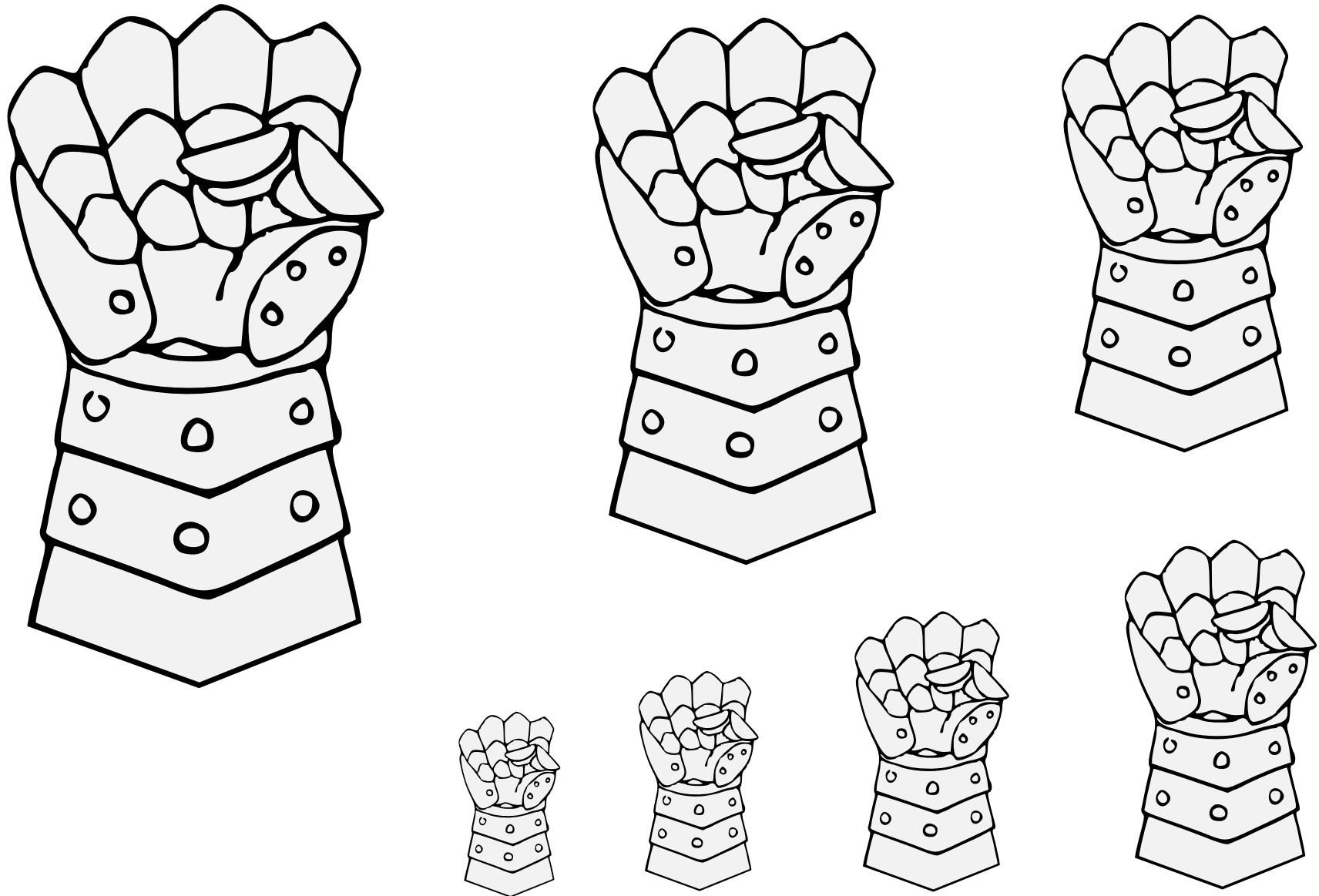

A armored human hand with fingers clenched.  
Default orientation: dexter hand, fingers to chief.  
No proper coloration.  
Source: Pennsic Traceable Art. Artist: Unknown.

Gauntlet, Clenched (2)    21.119

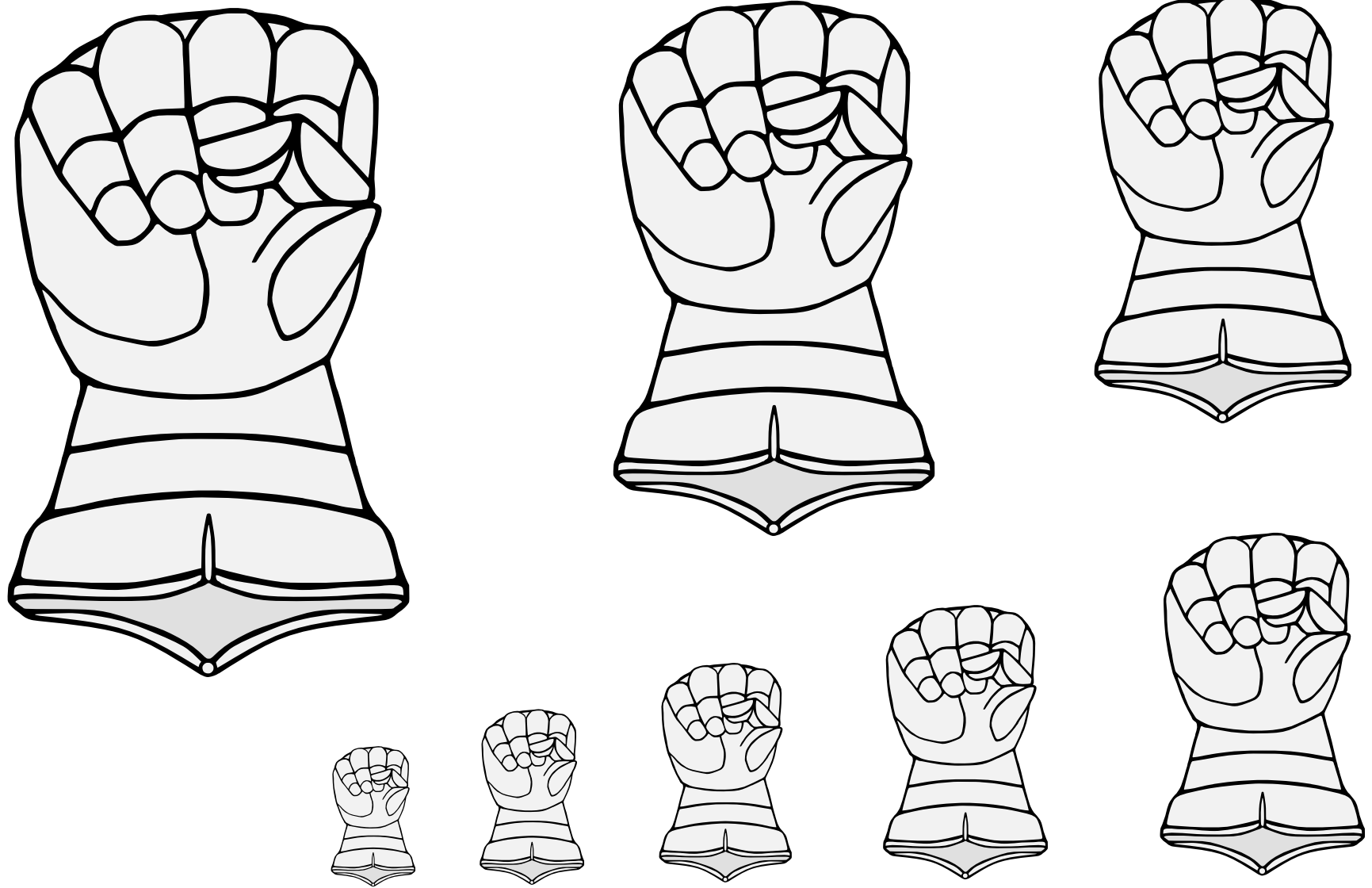

A armored human hand with fingers clenched.  
Default orientation: dexter hand, fingers to chief.  
No proper coloration.  
Artist: Jessimond of Emerickeskepe.

Gauntlet, Clenched (3) 21.120

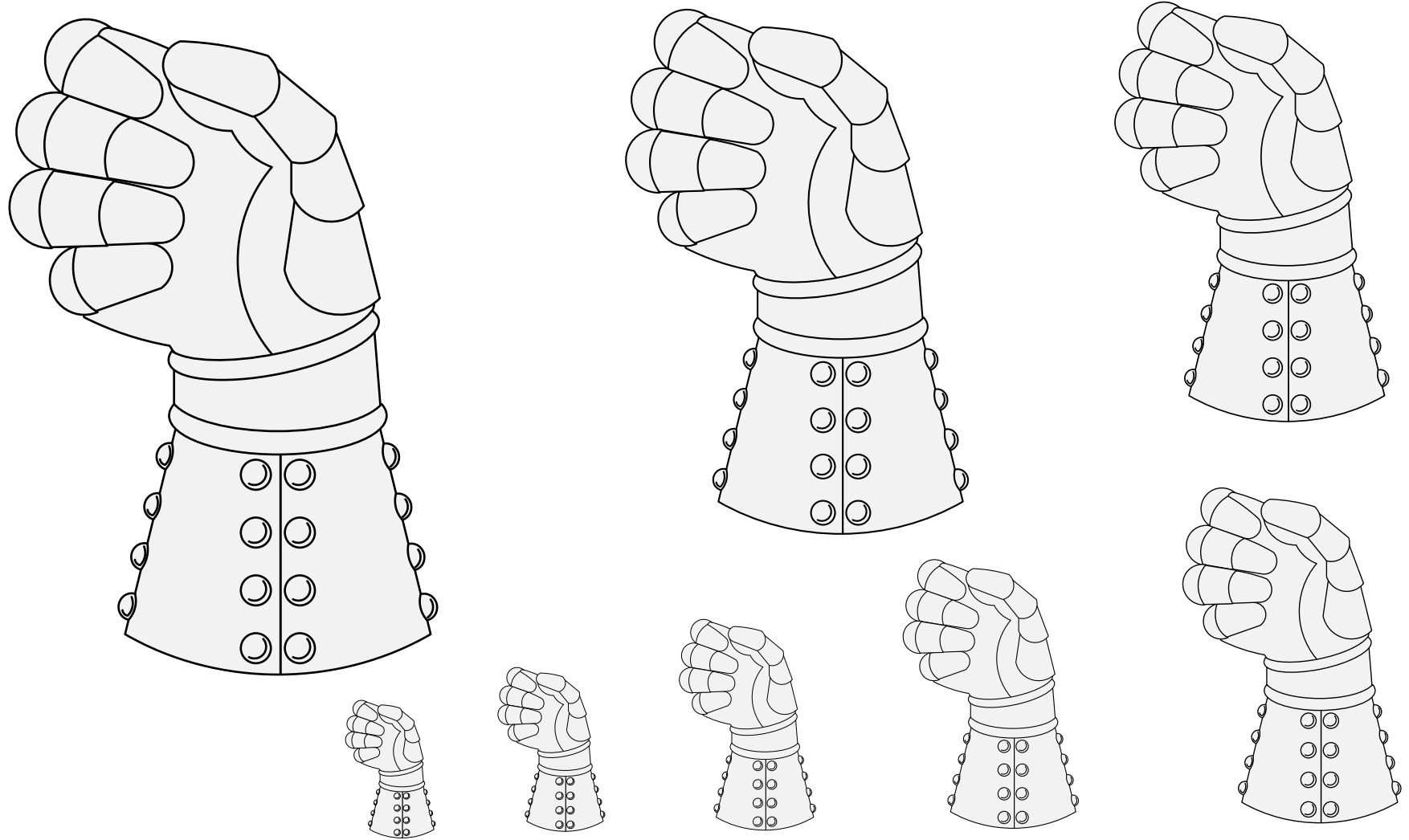

A piece of armor to cover the hand.

Default orientation: dexter hand apaumy.

The term “clenched” signifies that the hand is making a fist.

Source: Viking Answer Lady

SVG Images For Heralds.

Artist: Gunnvôr silfrahárr.

**Gauntlet, Clenched, Flexed at the Wrist** 21.121

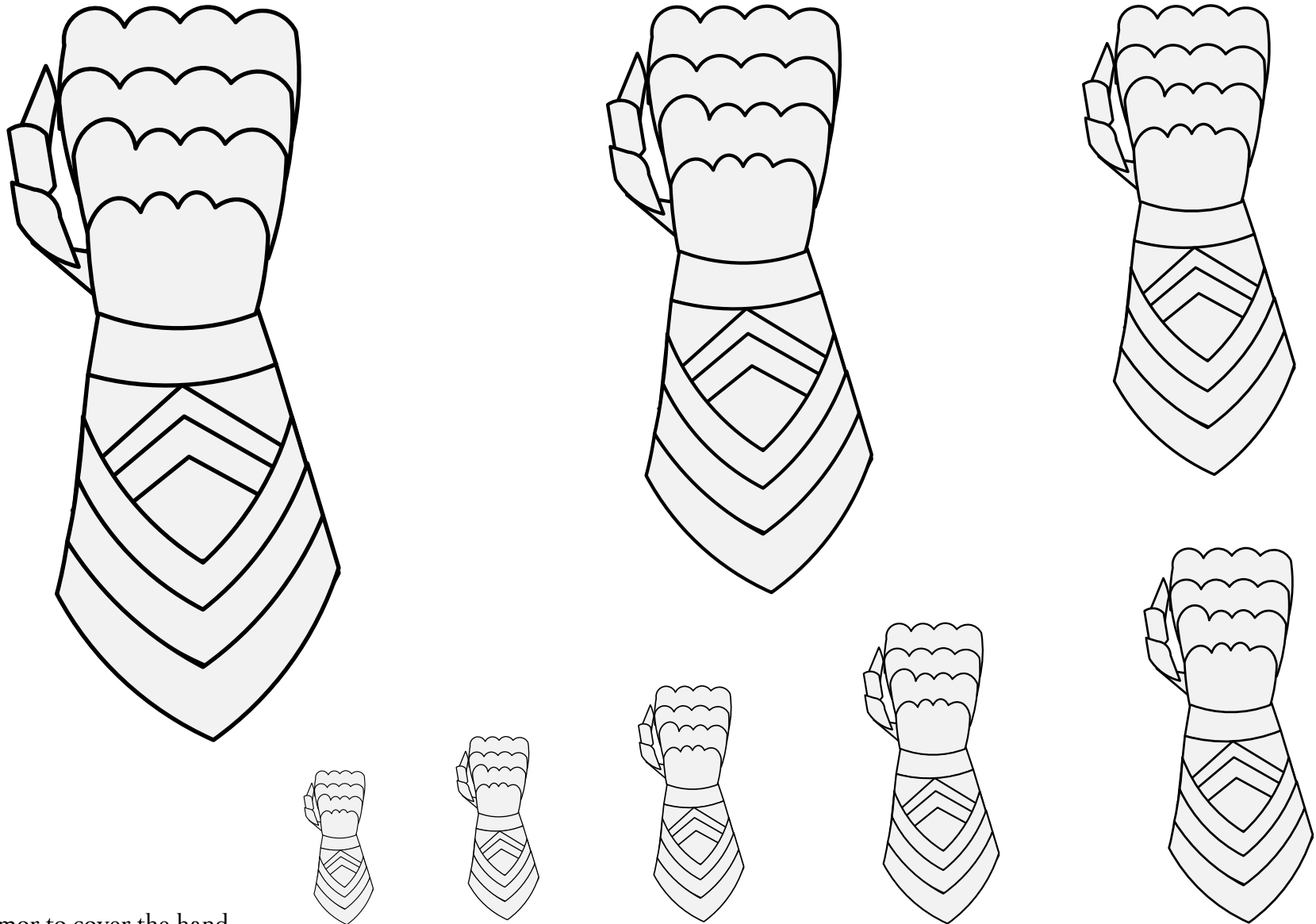

A piece of armor to cover the hand.

Default orientation: dexter hand apaumy.

The term “aversed” signifies that the back of the hand is turned towards the viewer.

Source: Viking Answer Lady SVG Images For Heraldry.

Artist: Gunnvôr silfrhárr.

**Gauntlet Aversed (1)** • 21.122

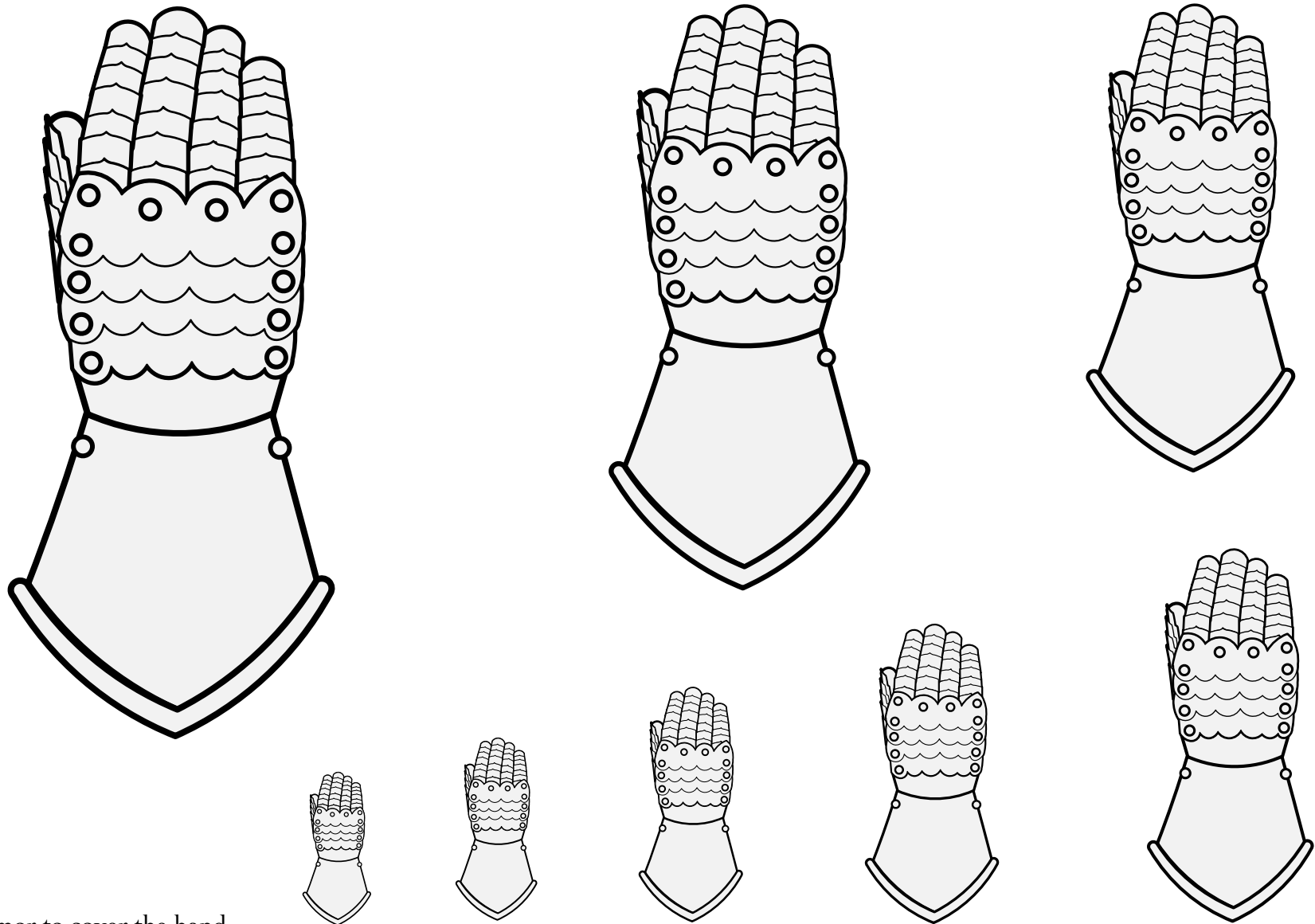

A piece of armor to cover the hand.

Default orientation: dexter hand apaumy.

The term “aversed” signifies that the back of the hand is turned towards the viewer.

Source: Viking Answer Lady SVG Images For Heraldry.

Artist: Gunnvôr silfrhárr.

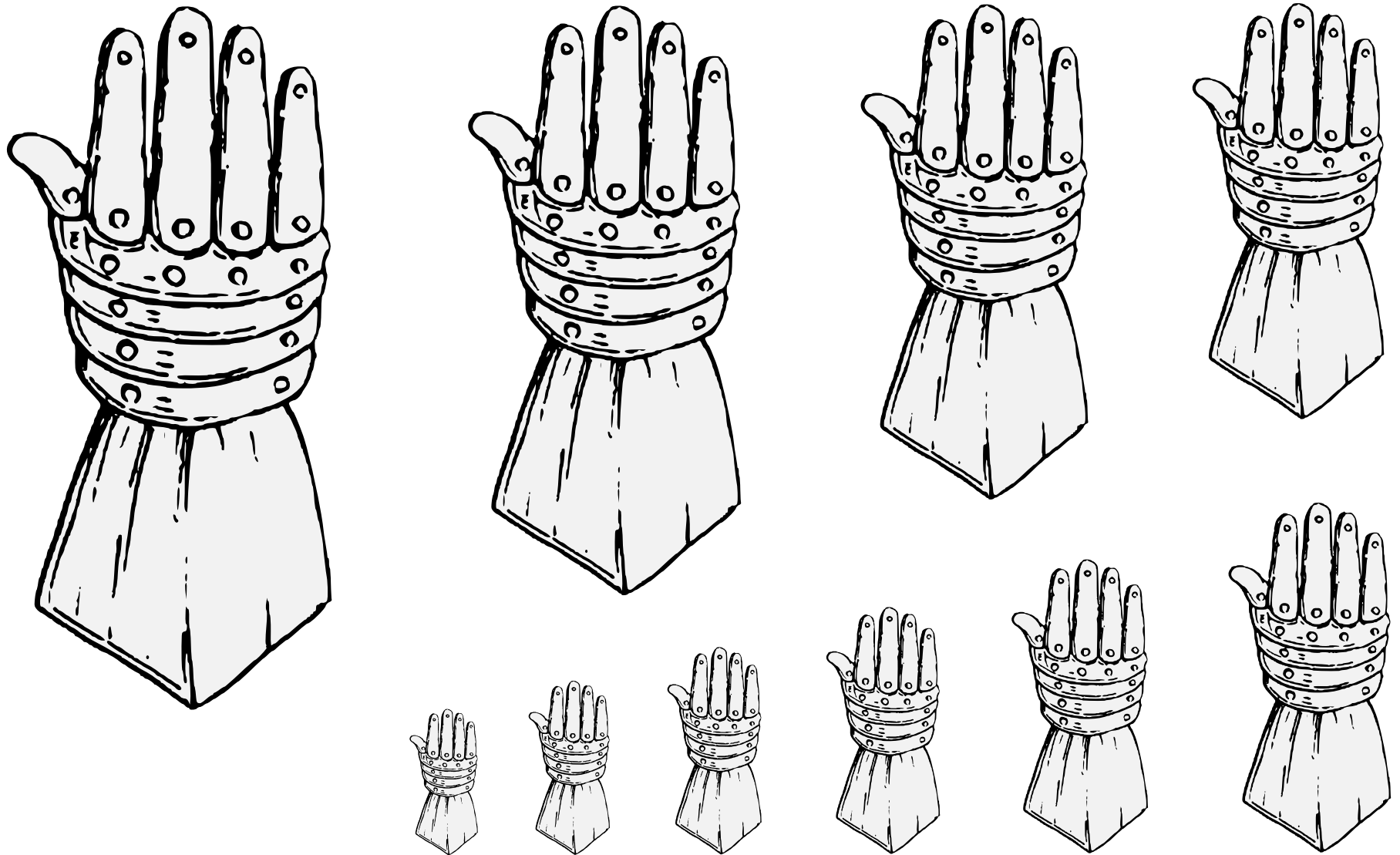

A piece of armor to cover the hand.

Default orientation: dexter hand apaumy.

The term “aversed” signifies that the back of the hand is turned towards the viewer.

Source: Encyclopædia Heraldica. (Volume 3, page 39.)

Artist unknown.

Gauntlet Aversed (3) • 21.124



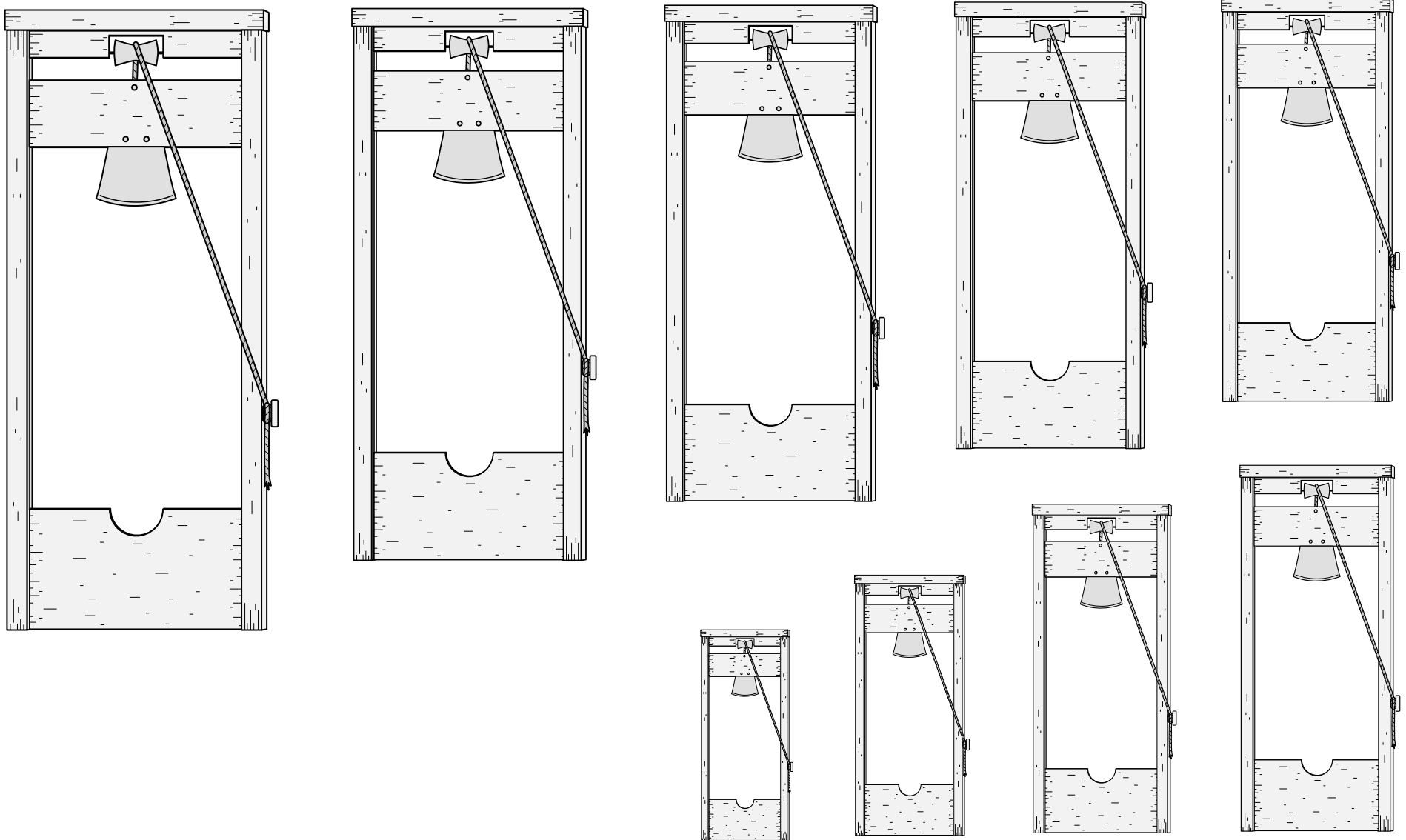

A medieval beheading machine similar to the guillotine.

Default orientation: upright. Proper coloration: brown wood.

Source: De Remediis Utriusque Fortunae. (1532 Steiner edition; BL 1613536198.)

Artist unknown. Adapted by Mathghamhain Ua Ruadháin.

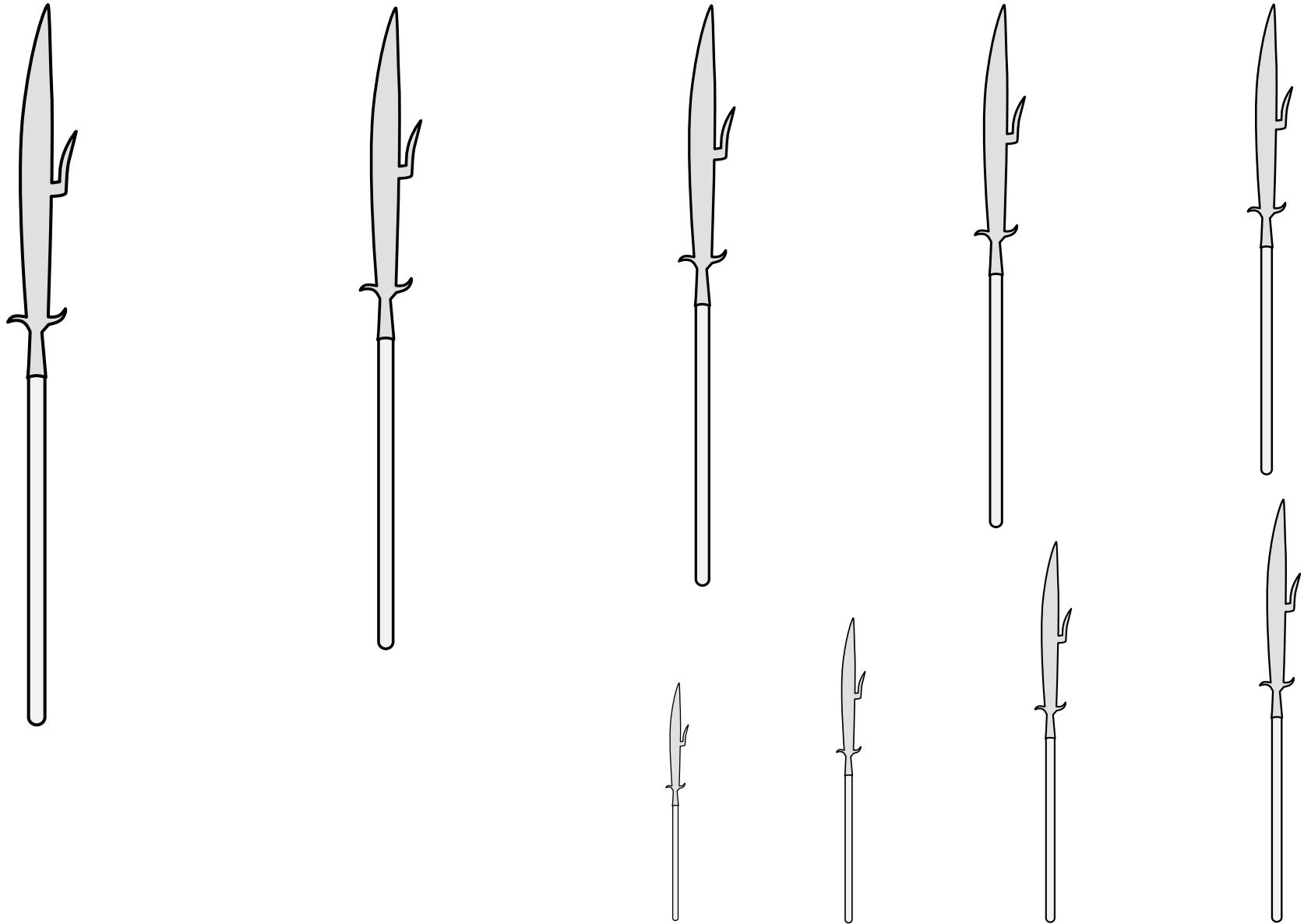

A sharp blade attached to a wooden shaft. Similar to a spear with sharp protruding hooks added.  
Default orientation: point to chief, cutting to dexter. No proper coloration.

**Glaive (1)** 21.126

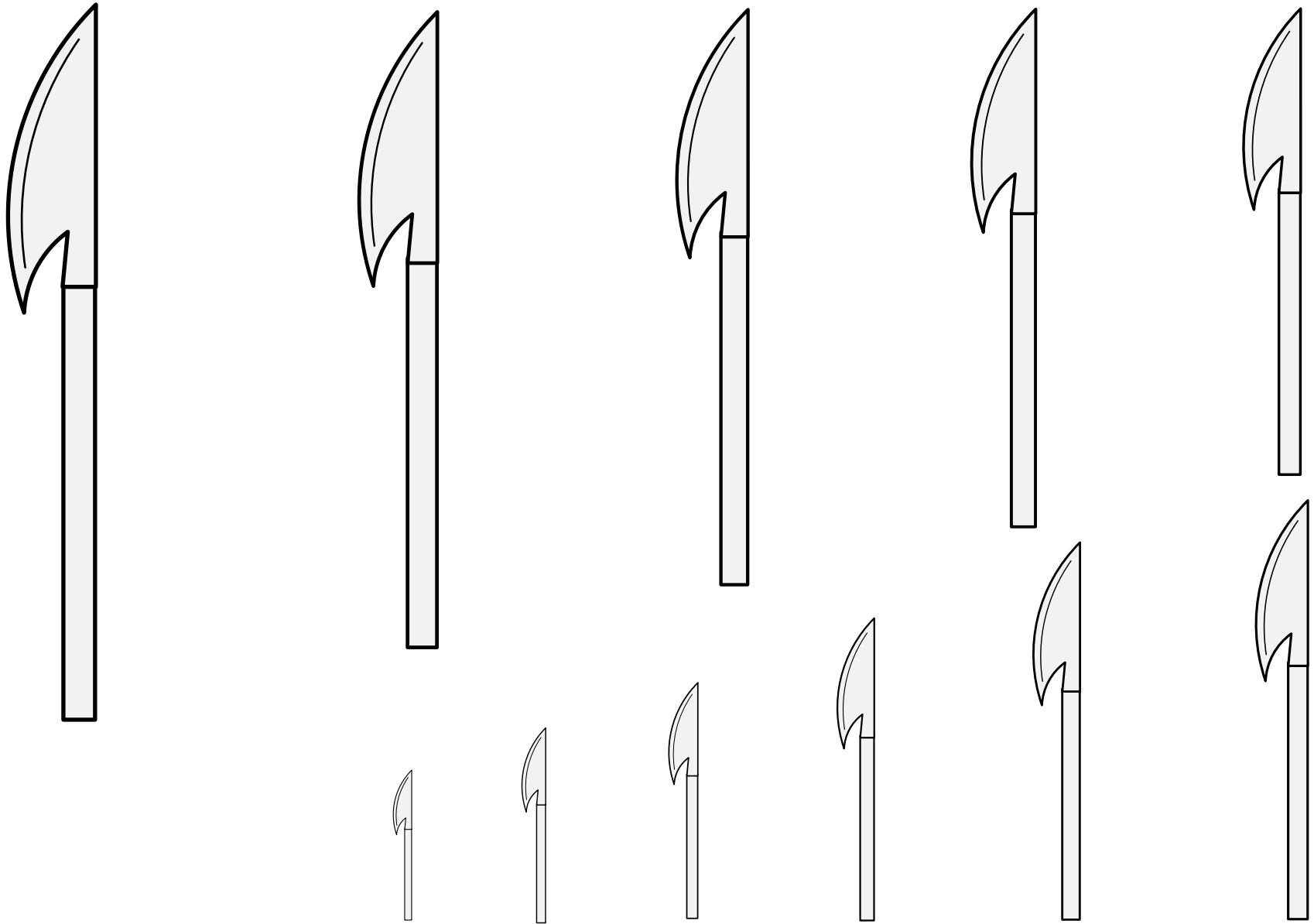

A sharp blade attached to a wooden shaft. Similar to a spear with sharp protruding hooks added.

Default orientation: point to chief, cutting to dexter. No proper coloration.

Source: Viking Answer Lady SVG Images For Heraldry. Artist: Gunnvôr silfrárr.

**Glaive (2)** • 21.127

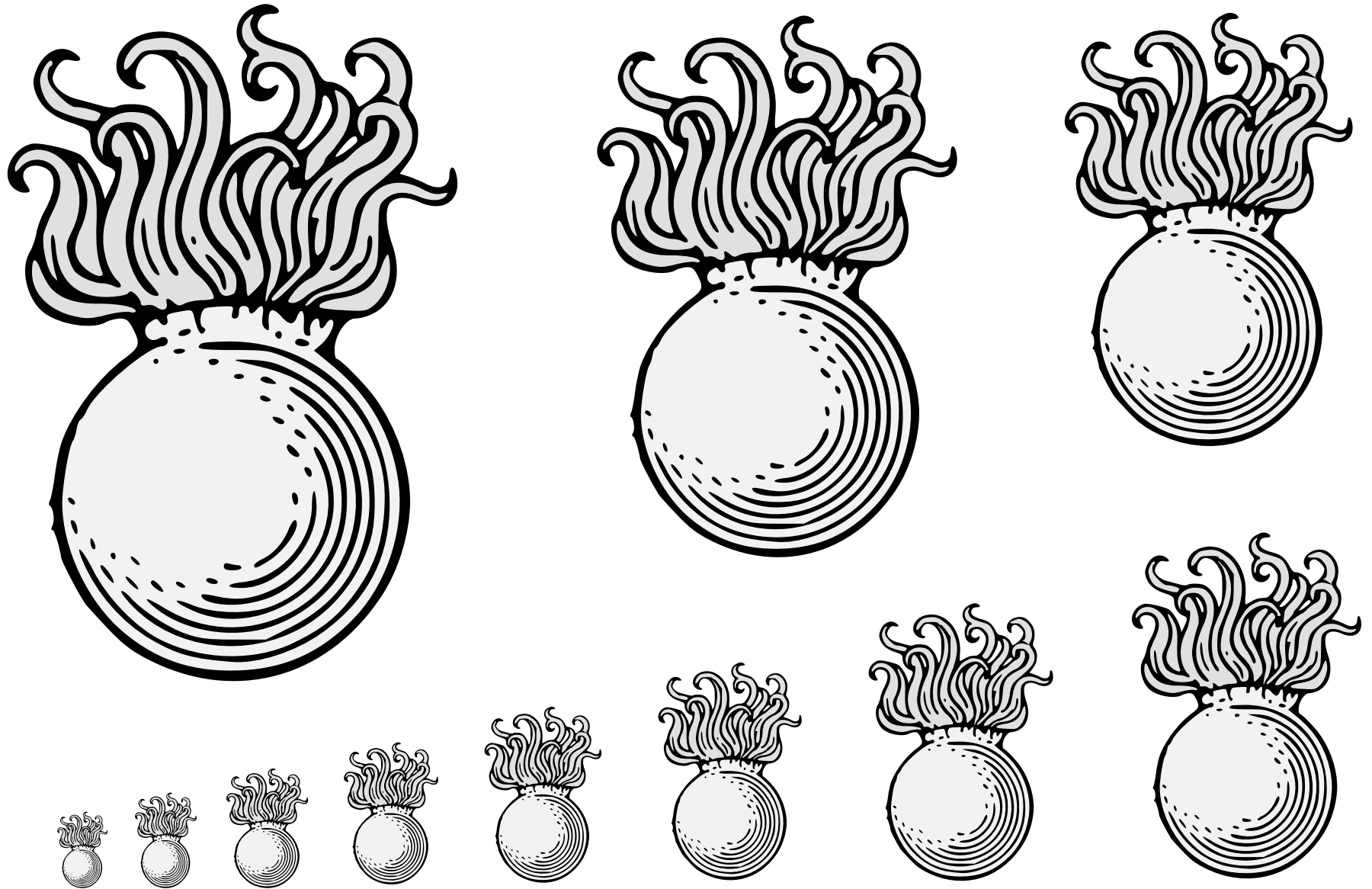

An incendiary weapon, spewing flames.

Default orientation: flame to chief. Proper coloration: sphere sable, flames alternately or and gules.

Source: A Complete Guide to Heraldry. Artist: Graham Johnston.

Grenade (1)    21.128

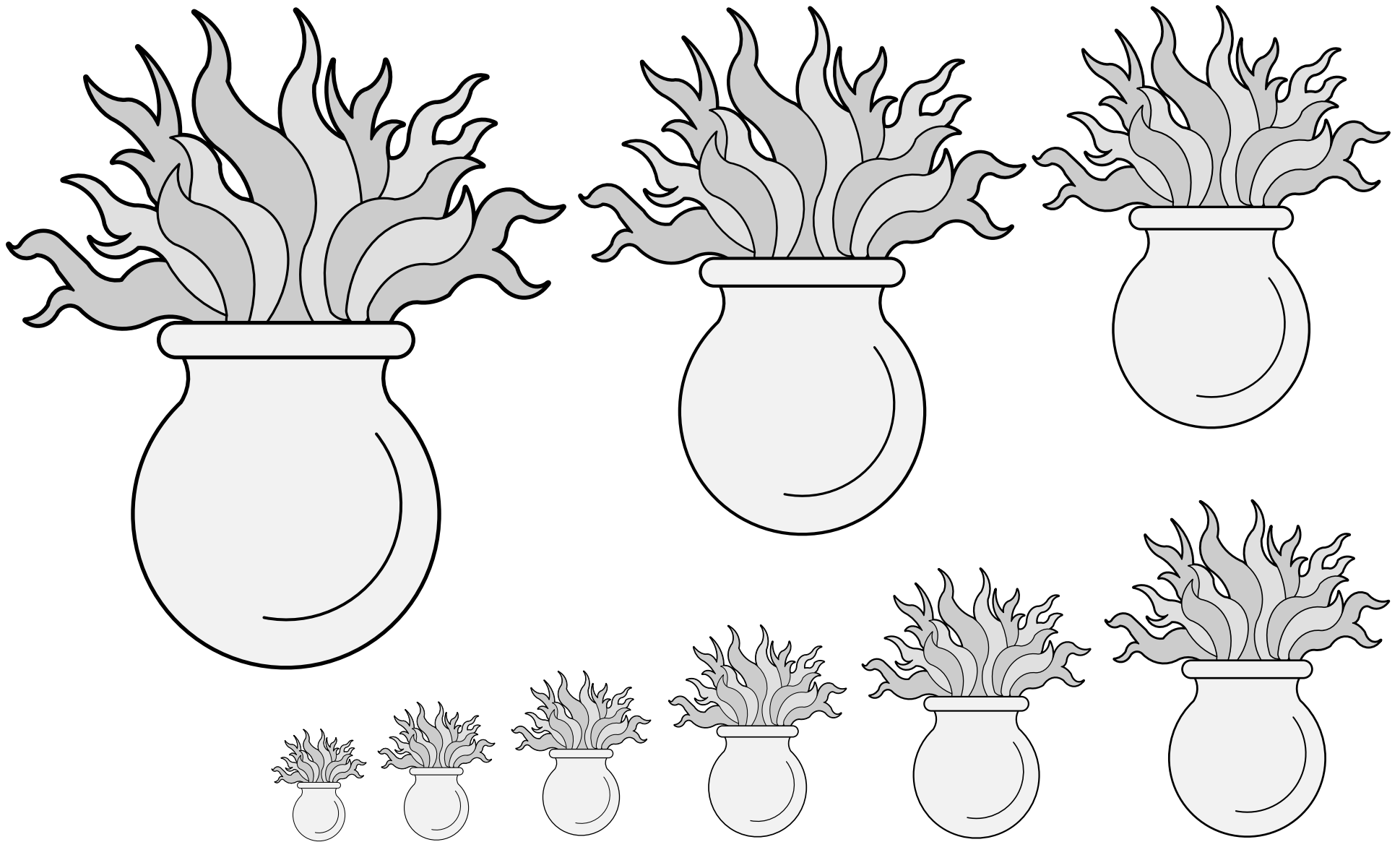

An incendiary weapon, spewing flames.

Default orientation: flame to chief. Proper coloration: sphere sable, flames alternately or and gules.

Source: Viking Answer Lady SVG Images For Heraldry. Artist: Gunnvôr silfráhr.

Grenade (2) 21.129

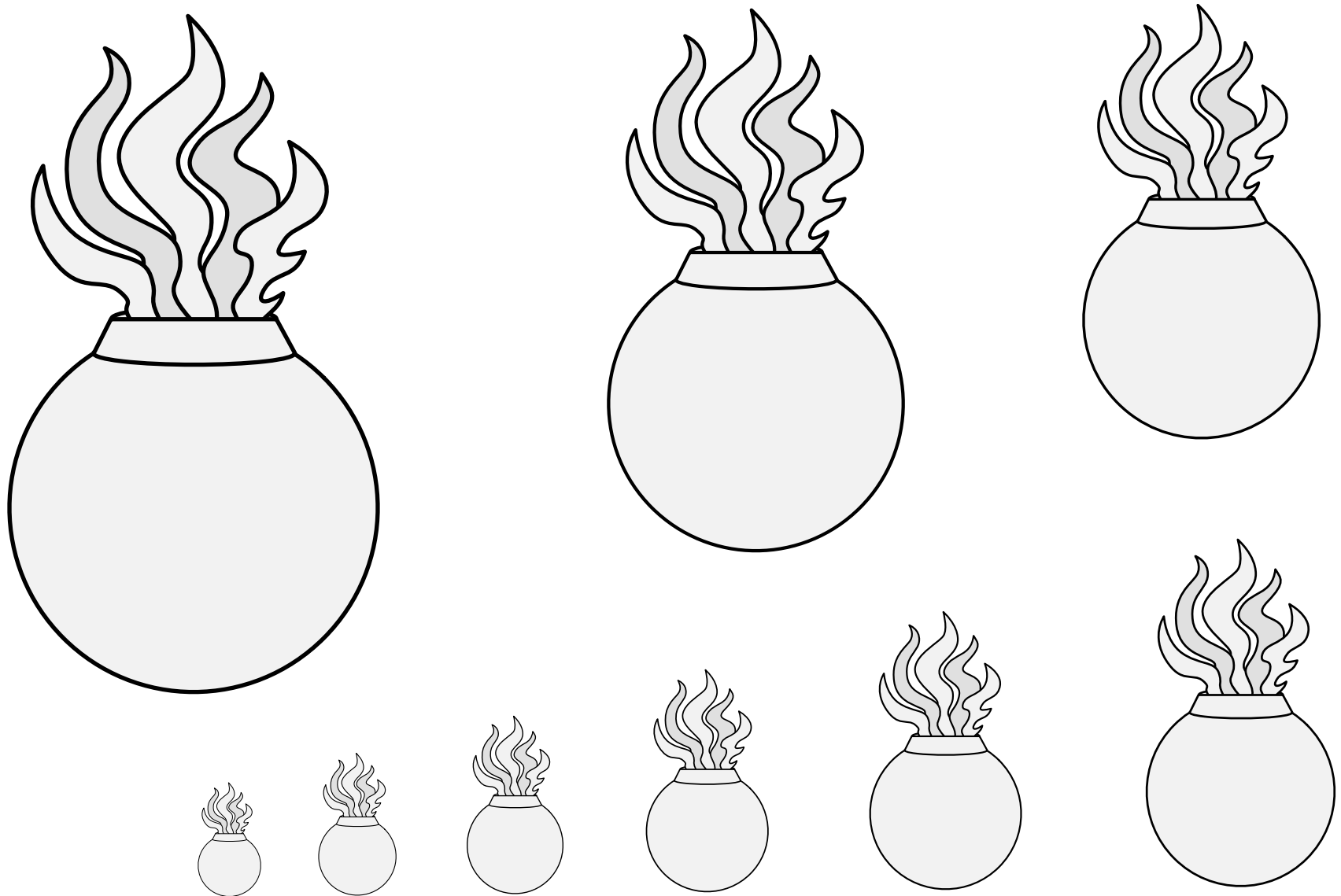

An incendiary weapon, spewing flames.

Default orientation: flame to chief. Proper coloration: sphere sable, flames alternately or and gules.

Grenade (3) 21.130

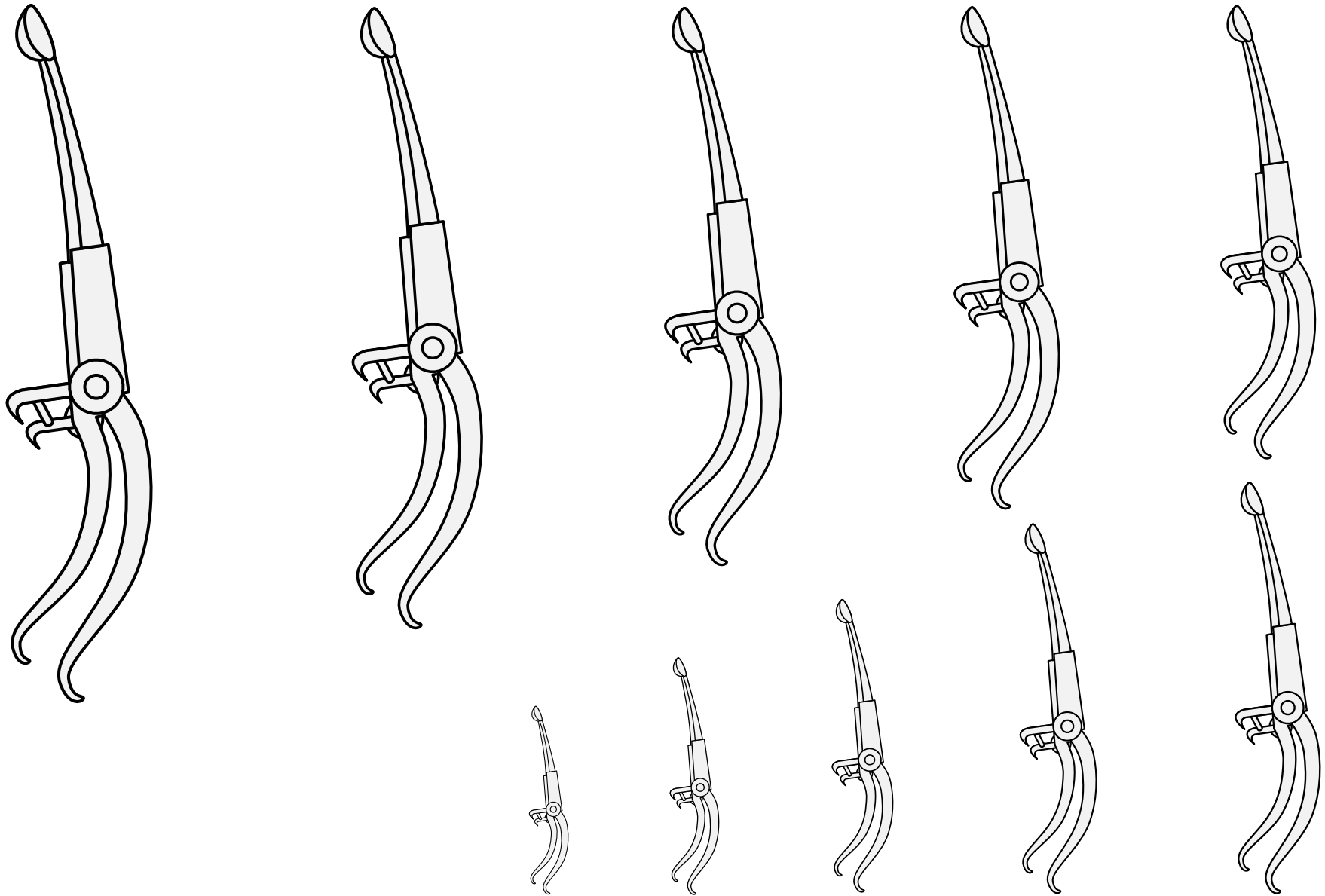

A mechanical lever used to span a crossbow.

No default orientation. No proper coloration.

Source: Nobiliario de Juan Pérez de Vargas. Artist unknown.  
Adapted by Mathghamhain Ua Ruadháin.

Goats Foot Lever 21.131

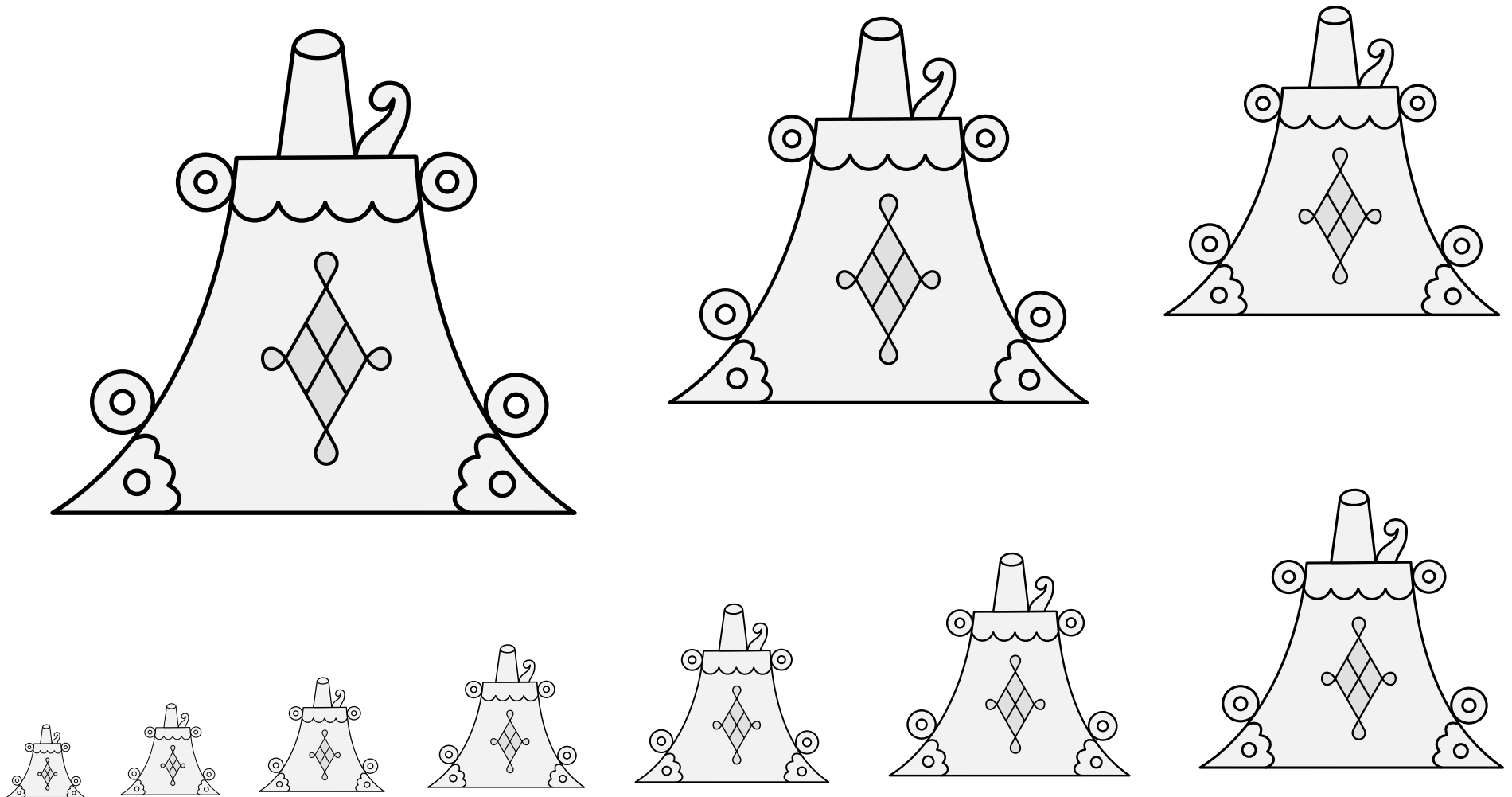

A portable container for black powder with a narrow opening to load into a gun barrel. Sometimes labeled a powder flask or powder horn.

Default orientation: spout to chief. No proper coloration.

Source: A Display of Heraldry. Artist: John Guillim.  
(Manuscript folio 95r.) Adapted by Iago ab Adam.

**Gun Flask** 21.132



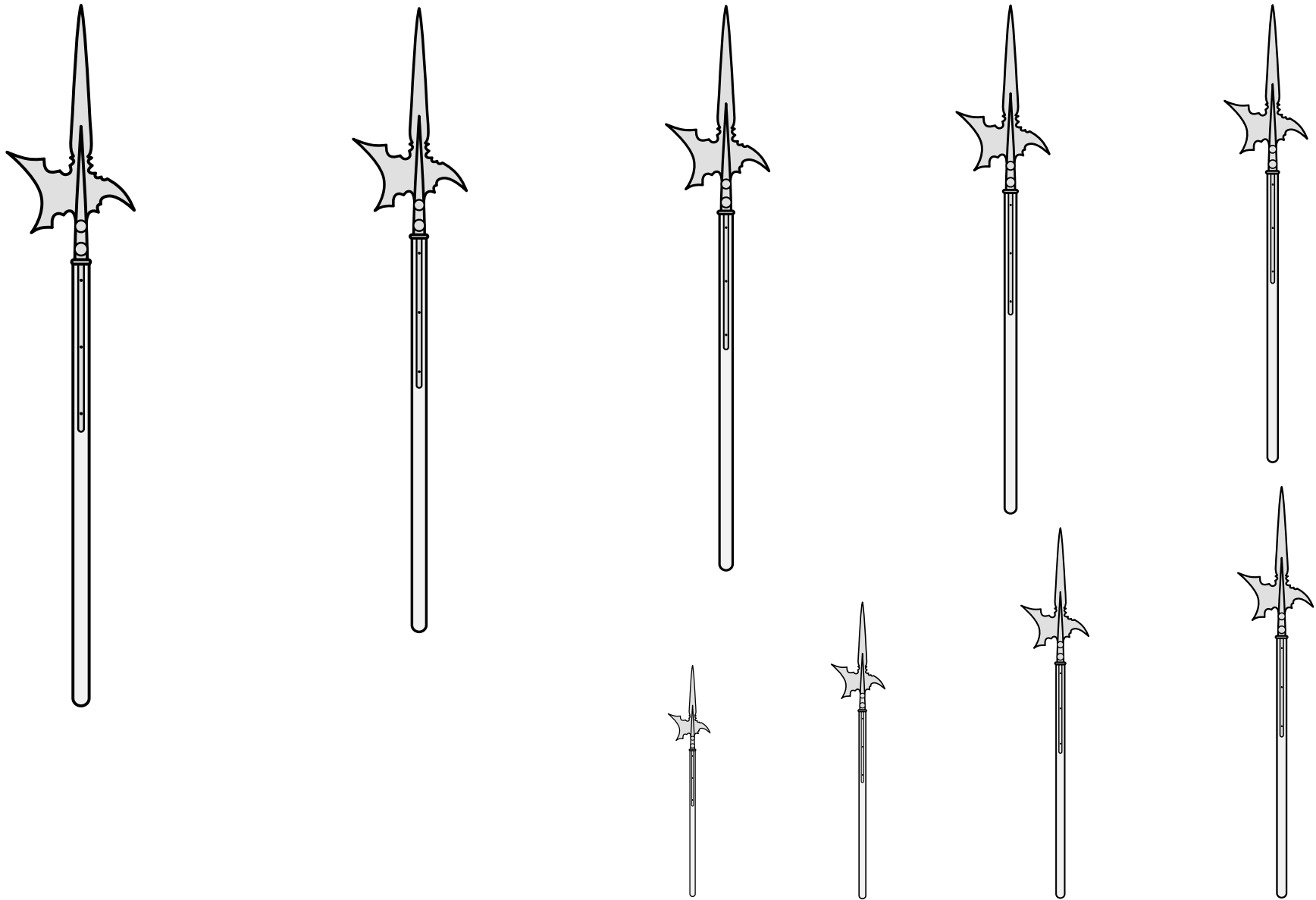

A war axe with a hook on the back and a long spike at the tip.  
Default orientation: point to chief, cutting to dexter. No proper coloration.

Halberd 21.133

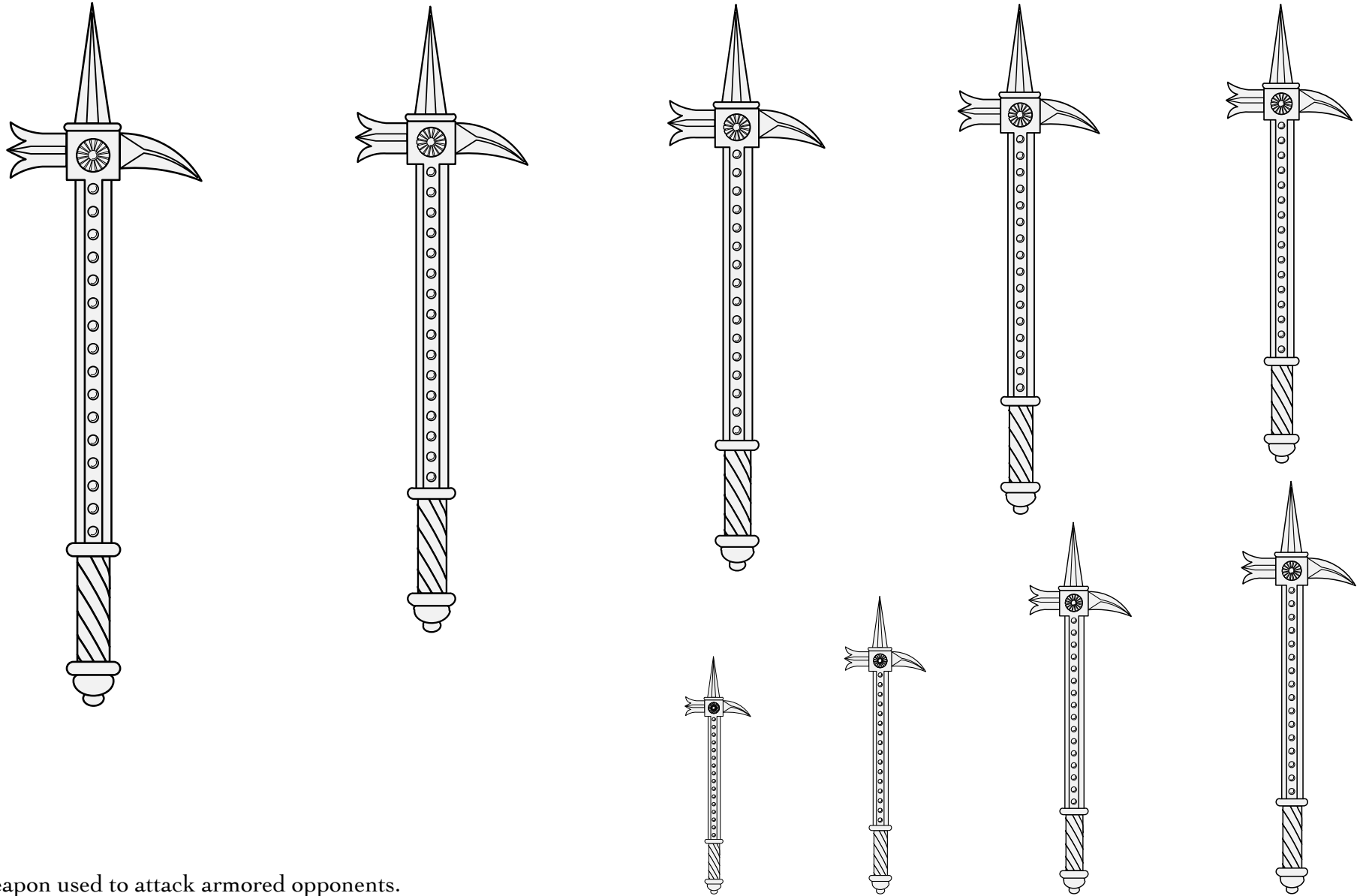

A weapon used to attack armored opponents.

Default orientation: head to chief, striking to dexter.

Proper coloration: sable head and brown wood handle.

Source: Viking Answer Lady SVG Images For Heraldry.

Artist: Gunnvör silfrhárr.

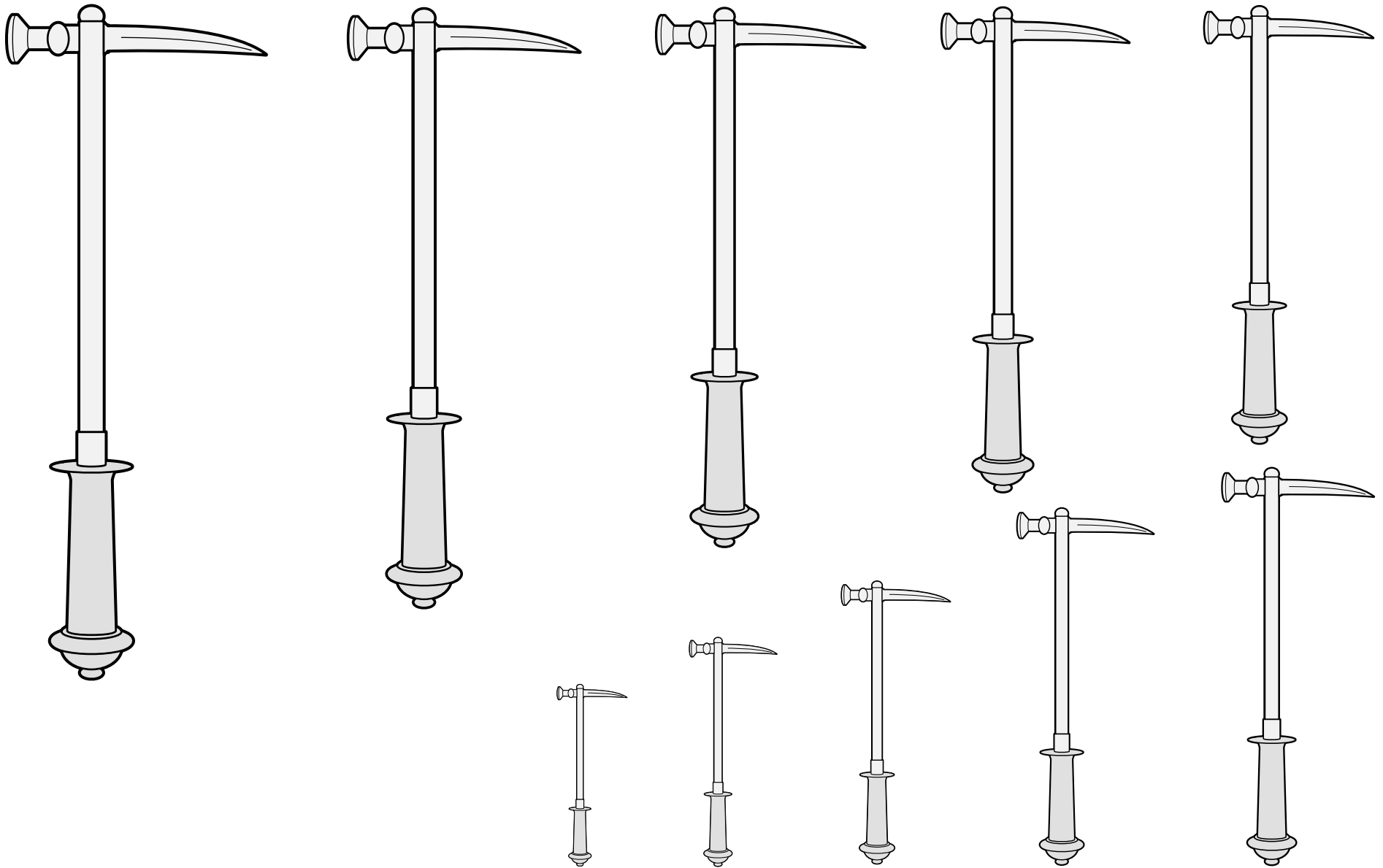

A weapon used to attack armored opponents.

Default orientation: head to chief, striking to dexter.

Proper coloration: sable head and brown wood handle.

Adapted from an image of a mid-16th century war hammer from Saxony.

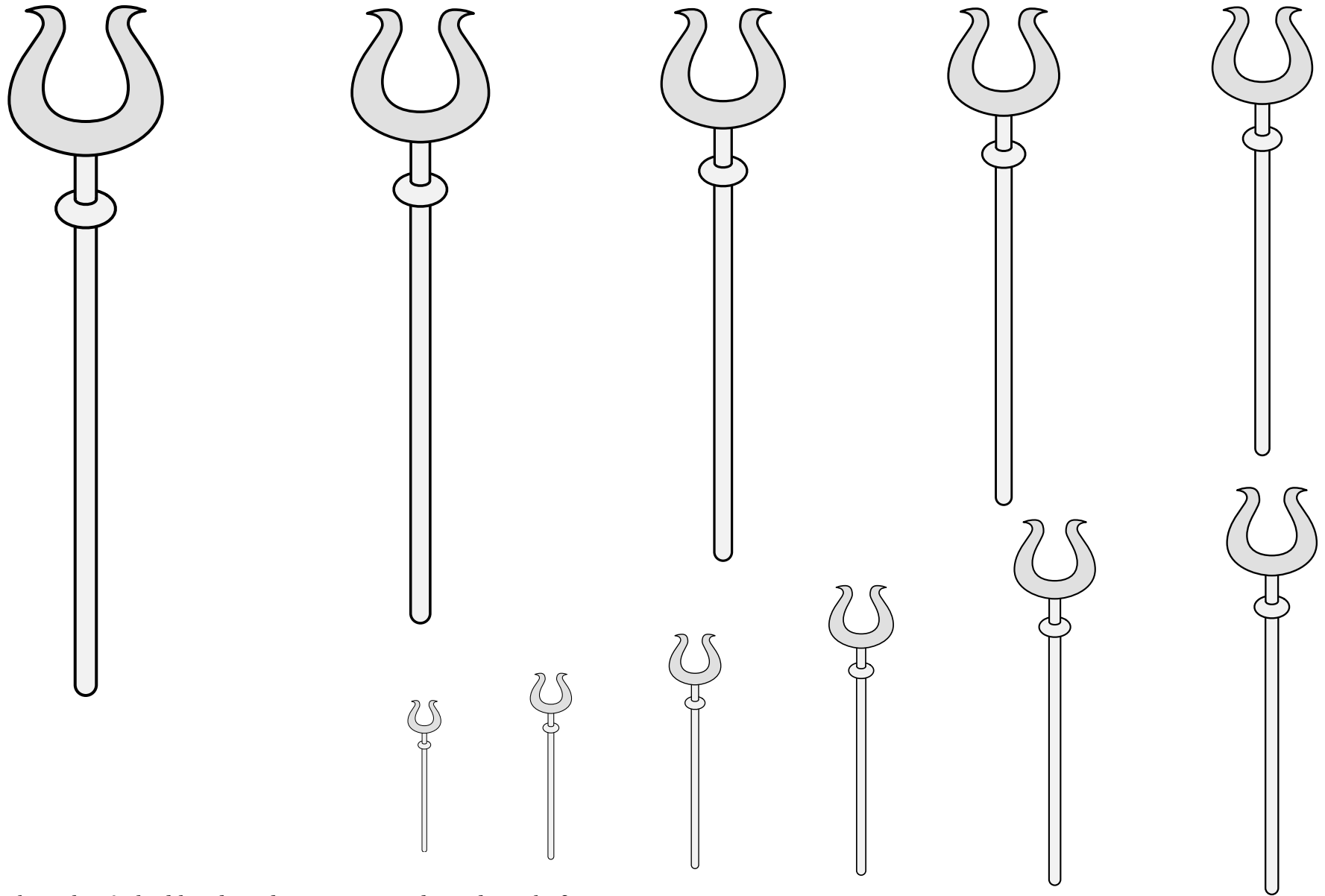

A tall pole with a forked head used to support and steady early firearms.

Default orientation: palewise, fork to chief. No proper coloration.

Source: Siebmacher's Wappenbuch of 1605. Artist: Johann Siebmacher.  
(Arms of Waldstromer von Reichelsdorf, page 108.)

Handgun Rest (1) • 21.136

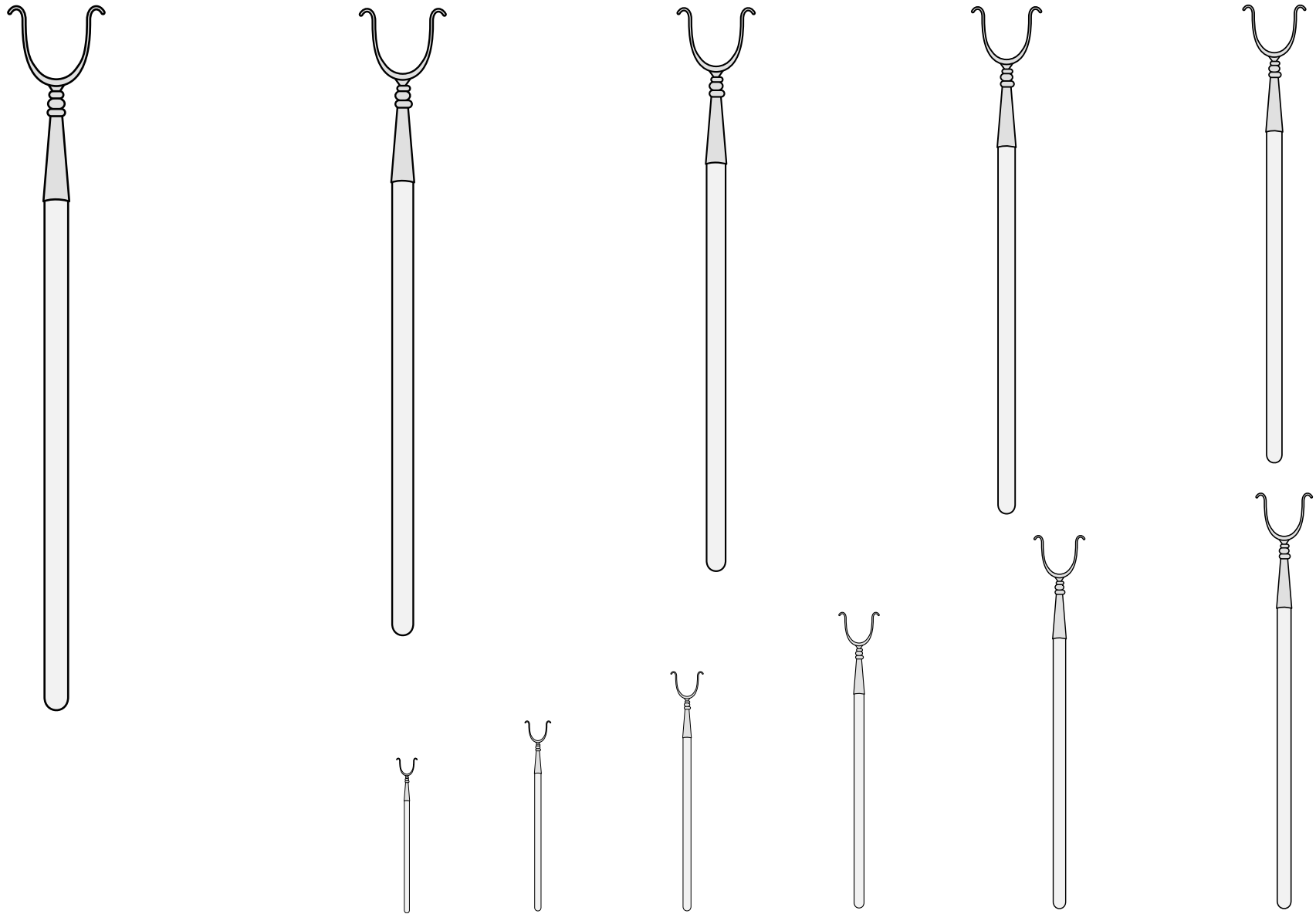

A tall pole with a forked head used to support and steady early firearms.  
Default orientation: palewise, fork to chief. No proper coloration.

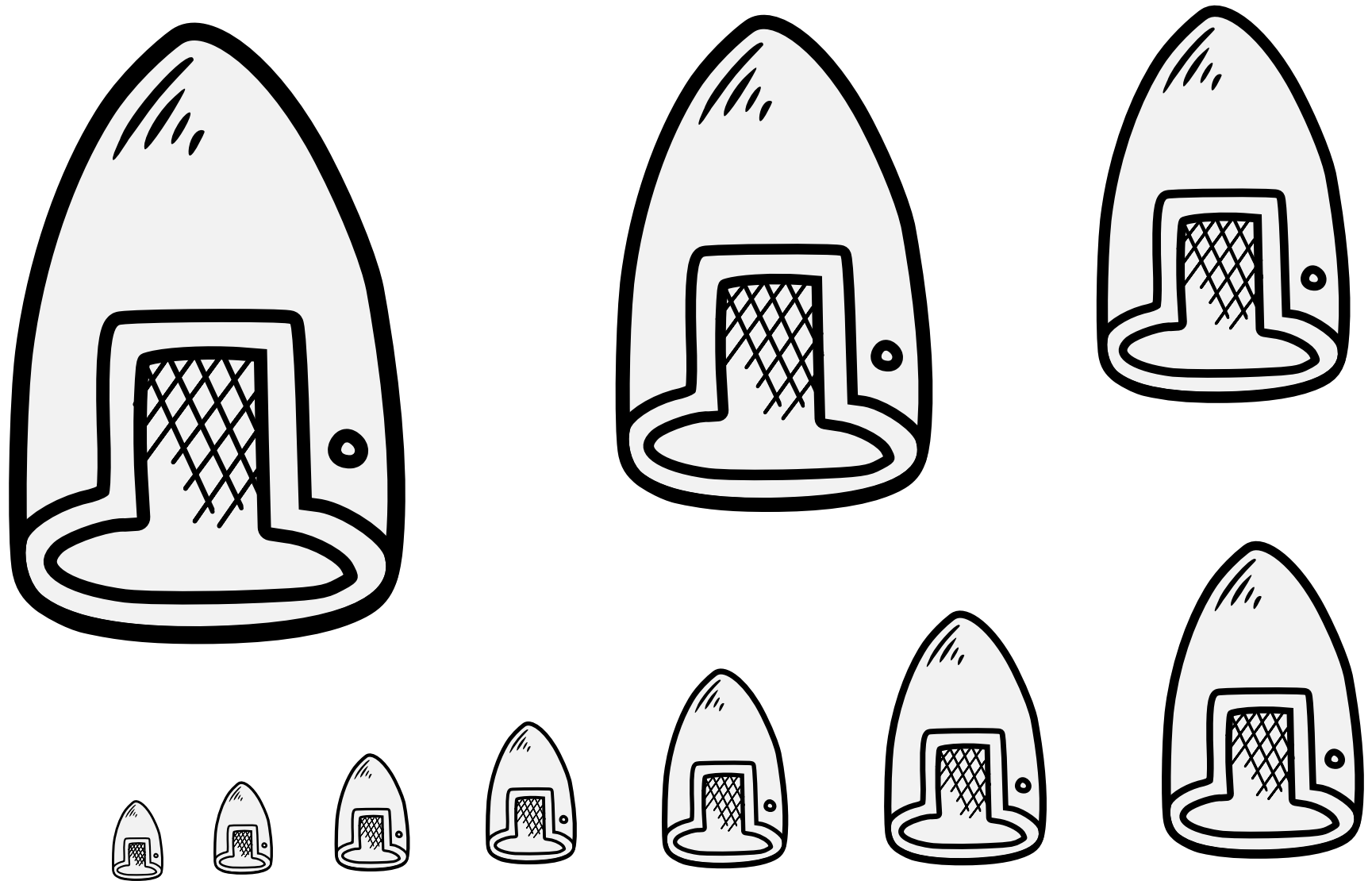

Protective armor for the head.

Default orientation: facing dexter. No proper coloration.

Source: Two Tudor Books of Arms. Artist: Robert Cooke. (Page 73.)

Helm Affronty 21.138

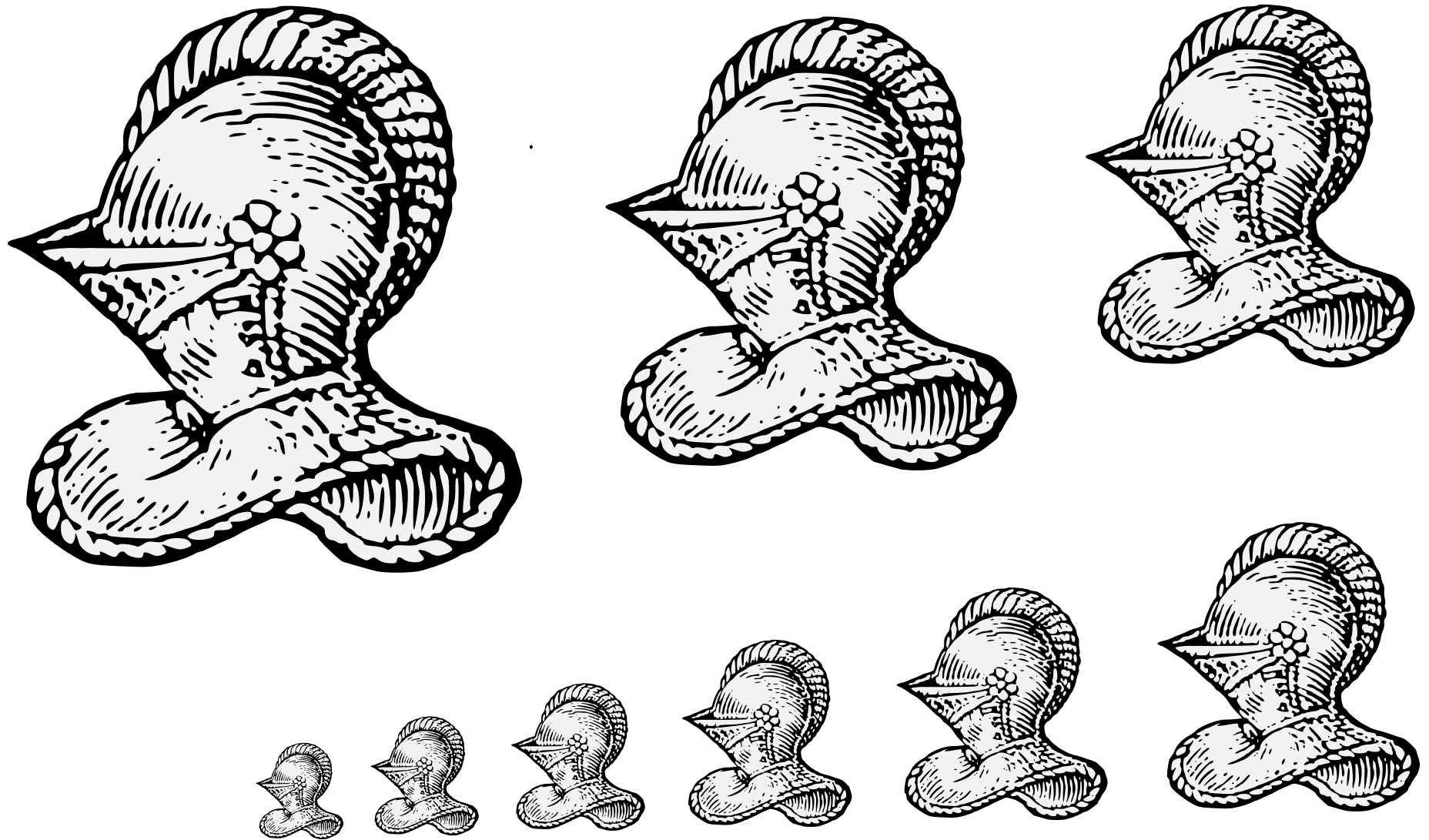

Protective armor for the head. The close helm is a sixteenth-century style.

Default orientation: facing dexter. No proper coloration.

Source: Guillim's Display of Heraldry. Artist unknown.

Helm, Close (1) 21.139

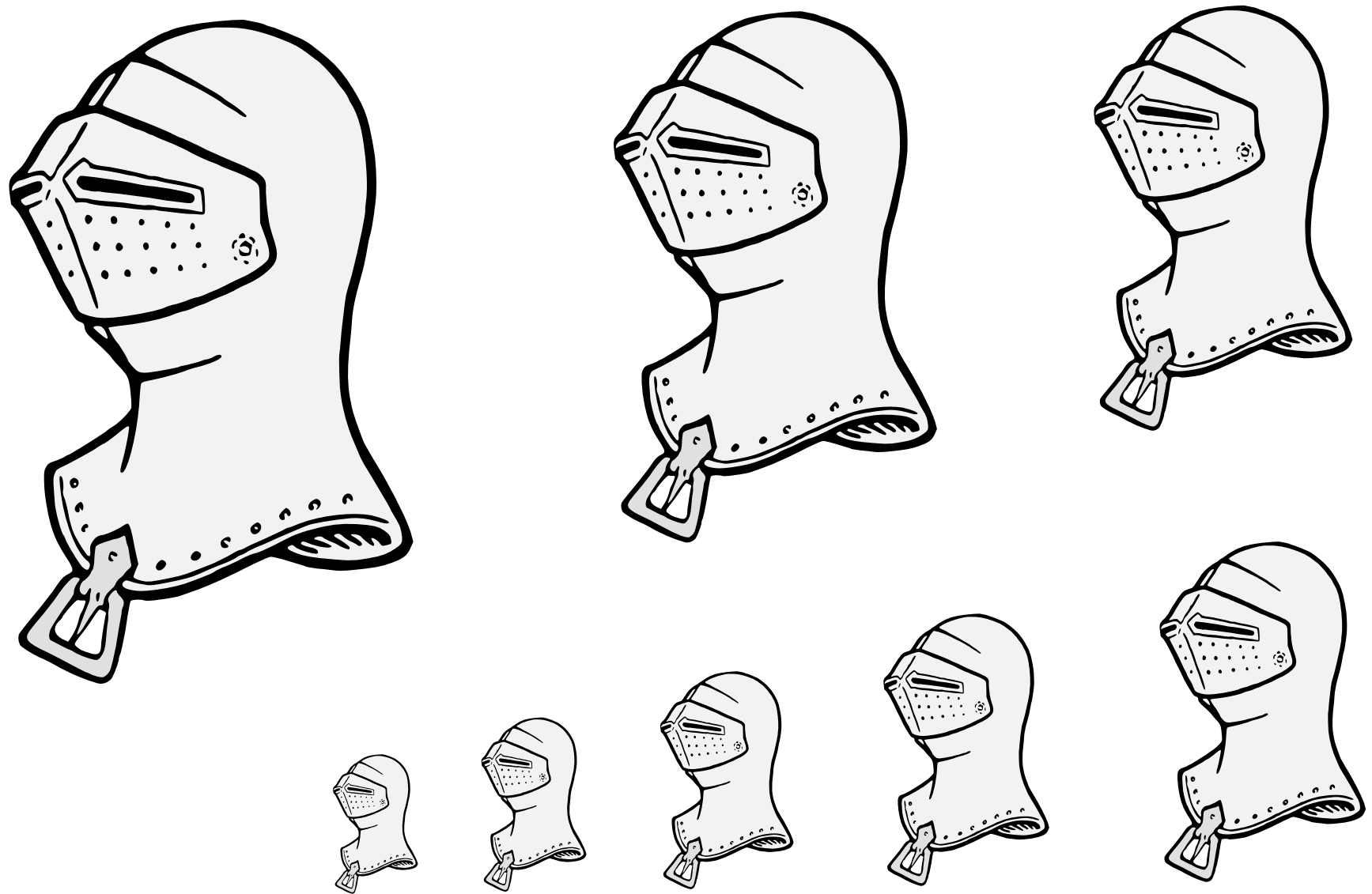

Protective armor for the head. The close helm is a sixteenth-century style.

Default orientation: facing dexter. No proper coloration.

Source: Some Feudal Lords and Their Seals. Artist unknown.

Helm, Close (2) 21.140



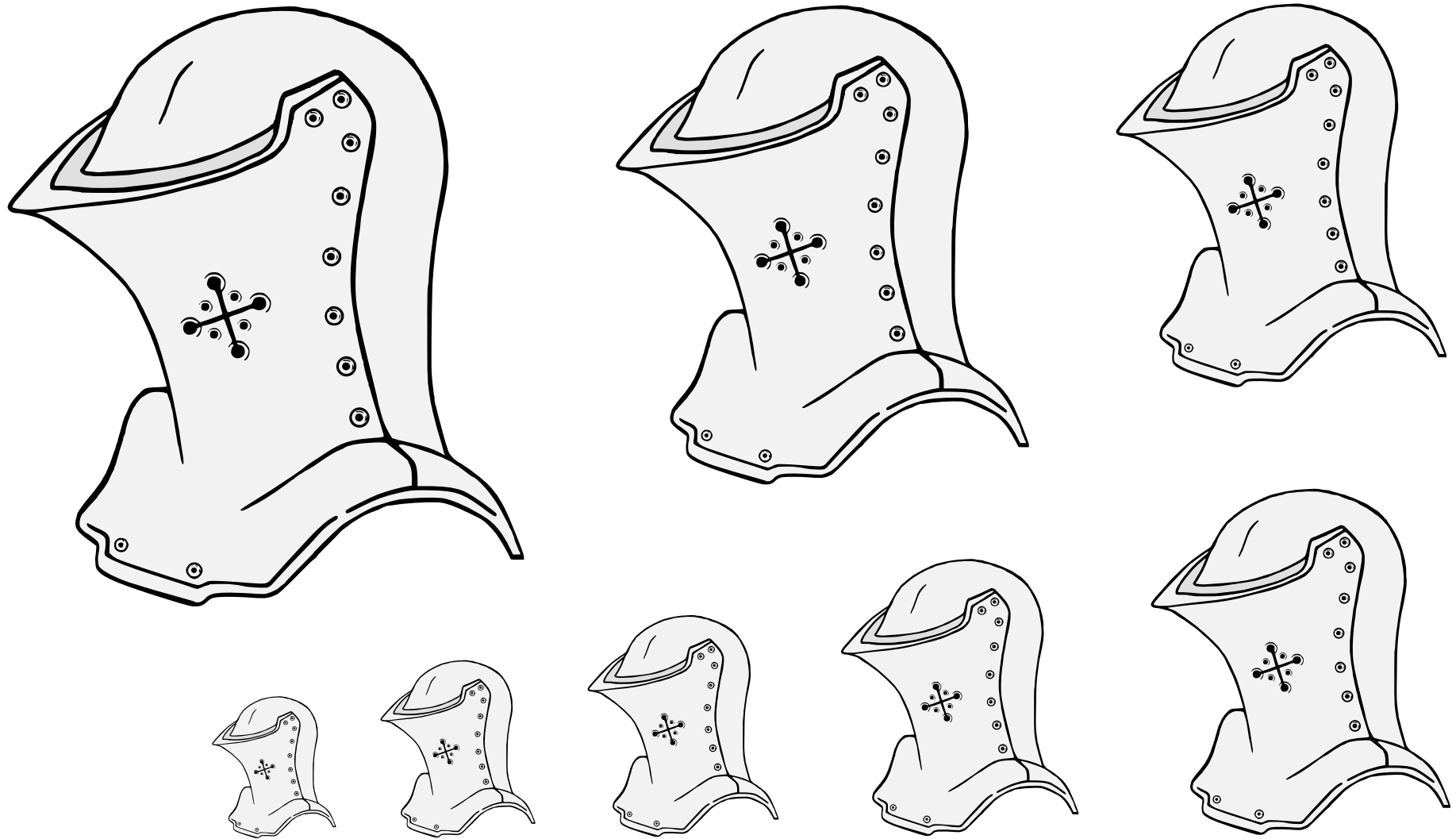

Protective armor for the head. The close helm is a sixteenth-century style.

Default orientation: facing dexter. No proper coloration.

Artist: Jessimond of Emerickeskepe.

Helm, Close (3) 21.141

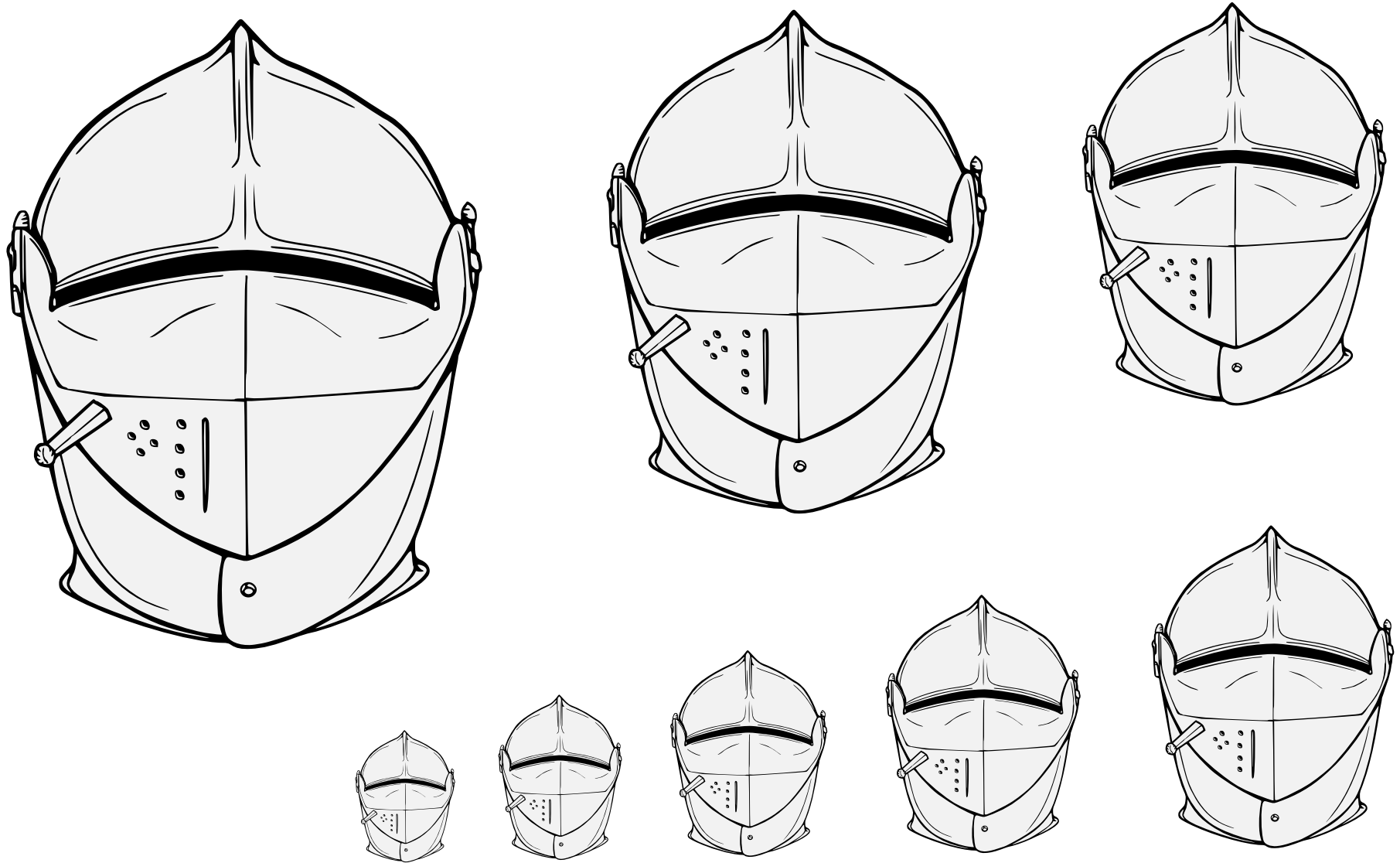

Protective armor for the head. The close helm is a sixteenth-century style.

Default orientation: facing dexter. No proper coloration.

Artist: Jessimond of Emerickeskepe. Adapted from images of an Italian armet (c. 1490) held by the Met Museum.

**Helm, Close, Affronty (1)** 🐉 21.142

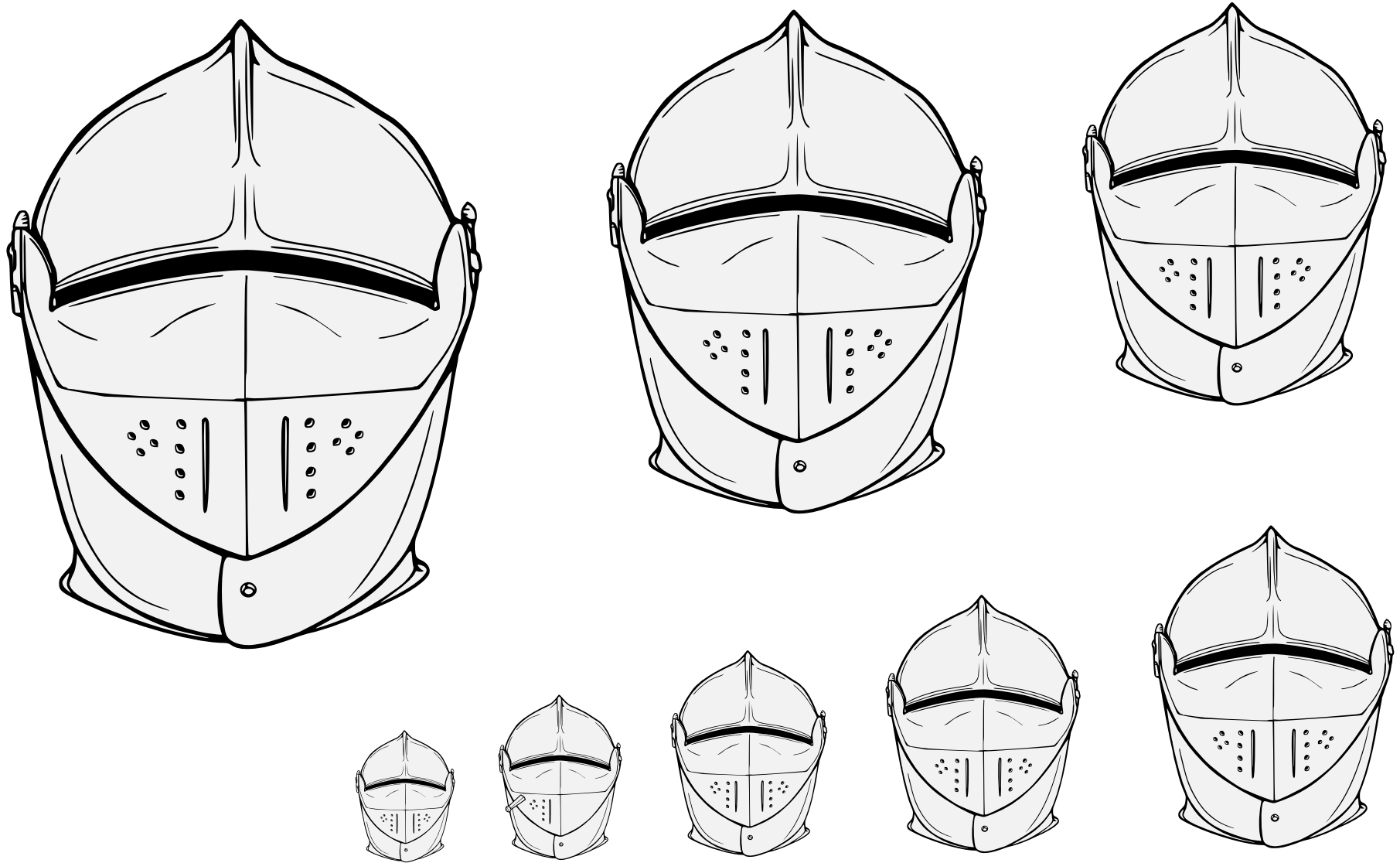

Protective armor for the head. The close helm is a sixteenth-century style.

Default orientation: facing dexter. No proper coloration.

Artist: Jessimond of Emerickeskepe. Adapted from images of an Italian armet (c. 1490) held by the Met Museum.

Helm, Close, Affronty (2) 21.143

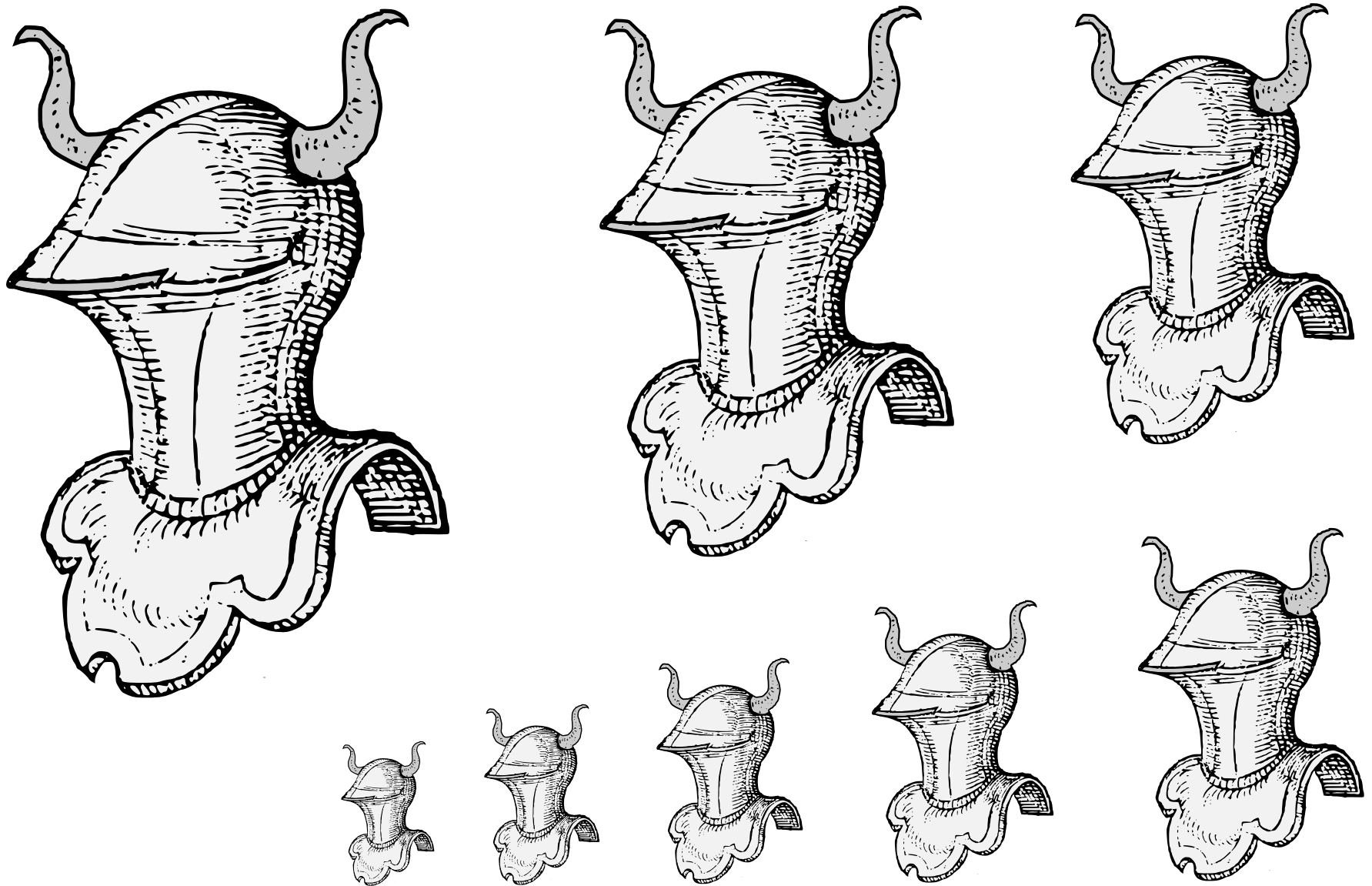

Protective armor for the head. The close helm is a sixteenth-century style.

Default orientation: affronty. (Most helms face to dexter by default, but horned helms are an exception.) No proper coloration.

Source: Arma Regni Poloniae. Artist unknown.  
(Herb of Helm, p. 84.)

Helm, Horned Close • 21.144

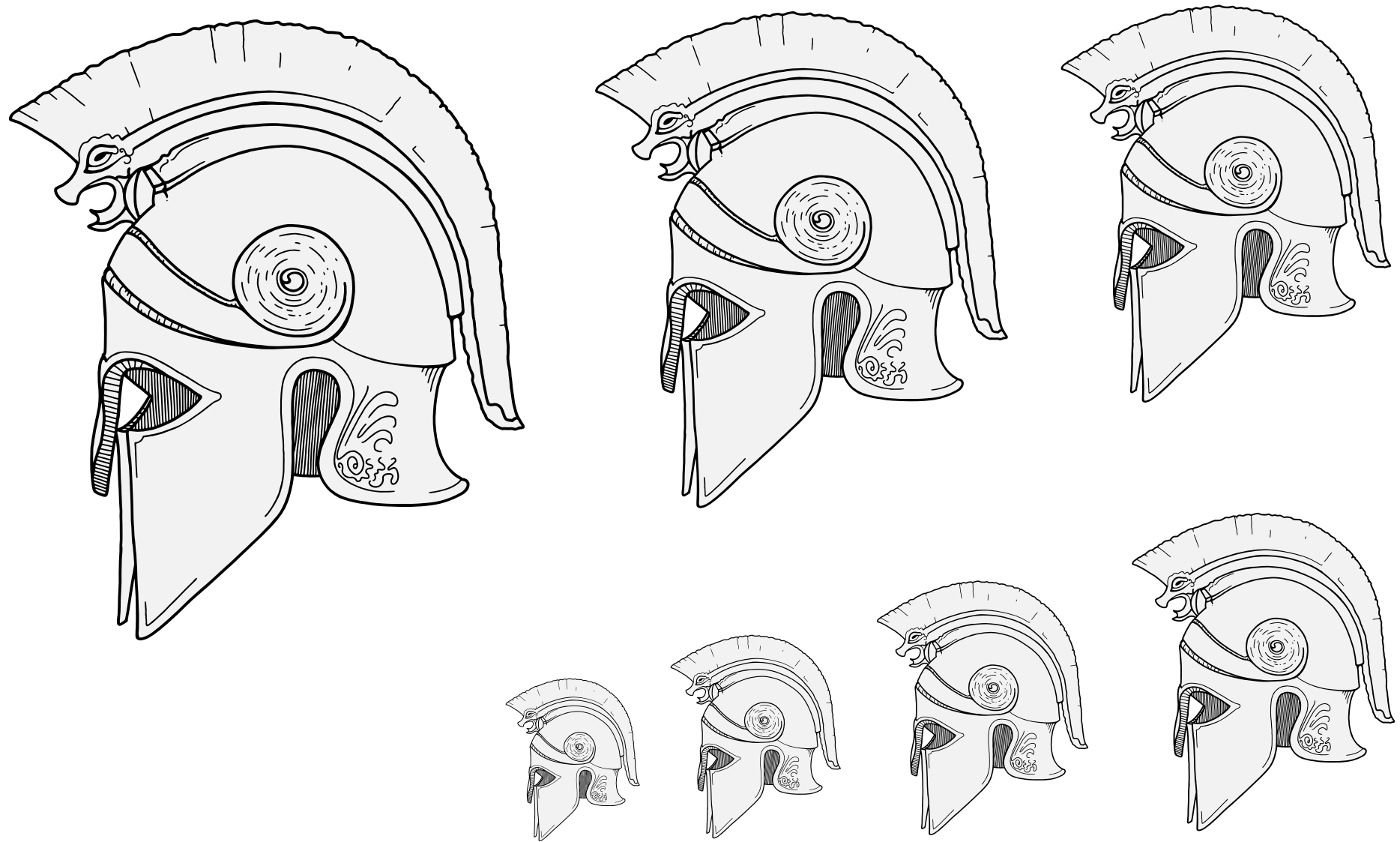

Protective armor for the head.

Default orientation: facing dexter. No proper coloration.

Artist: Ajir Tsagaan.

Helm, Corinthian 🍷 21.145

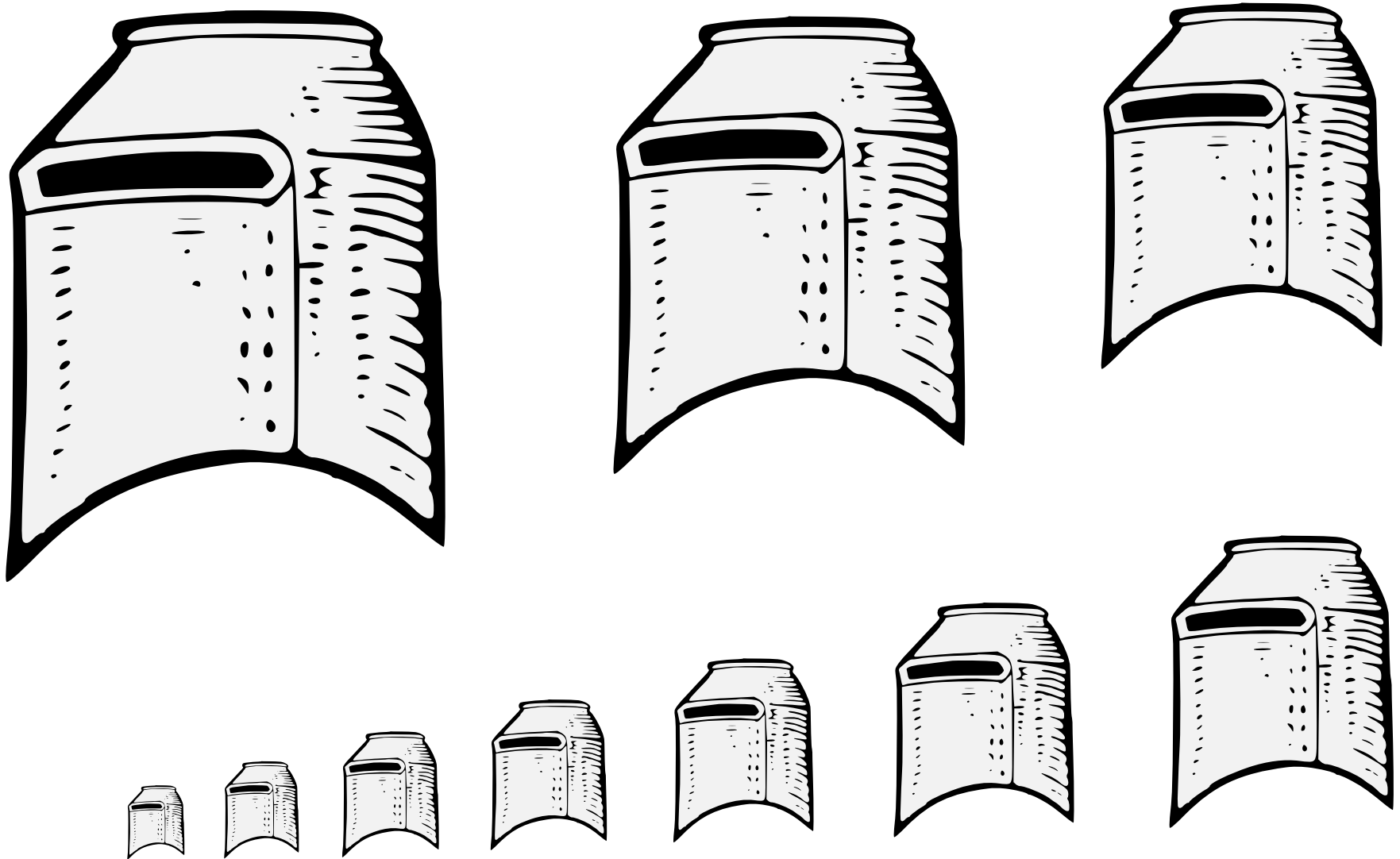

Armor for your head.

Default orientation: upright, facing dexter. No proper coloration.

Source: Baltischer Wappen-Kalender. Artist: M. Kortmann.

Helm, Great (1) 21.146

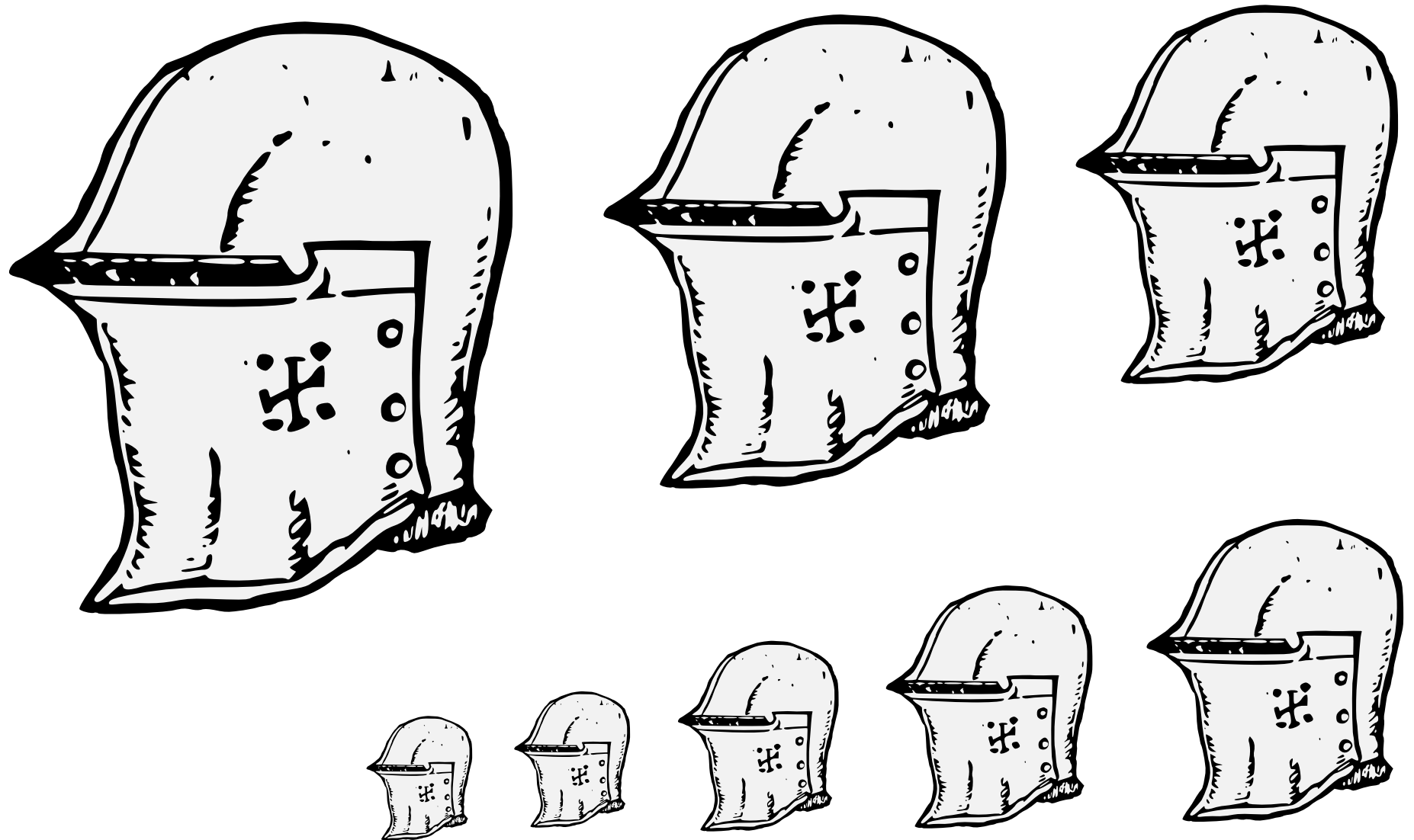

Protective armor for the head.

Default alignment: facing dexter. No proper coloration.

Source: The Accedence of Armorie. Artist unknown. (From folio 102r.)

Helm, Great (2) 21.147

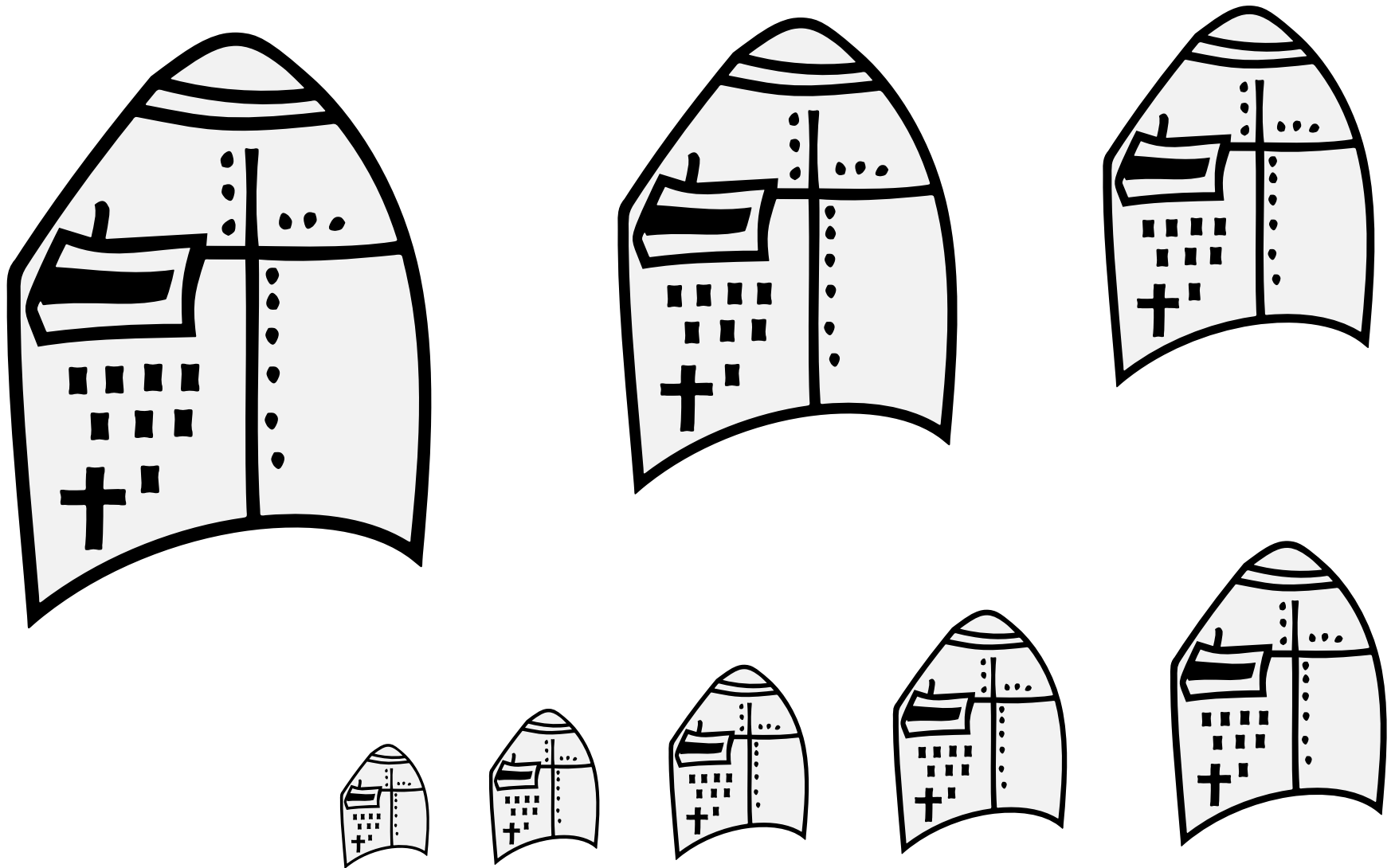

Protective armor for the head.

Default alignment: facing dexter. No proper coloration.

Source: Zurich Roll. Artist unknown. Adapted by Vémundr Syvursson.

Helm, Great (3) 21.148



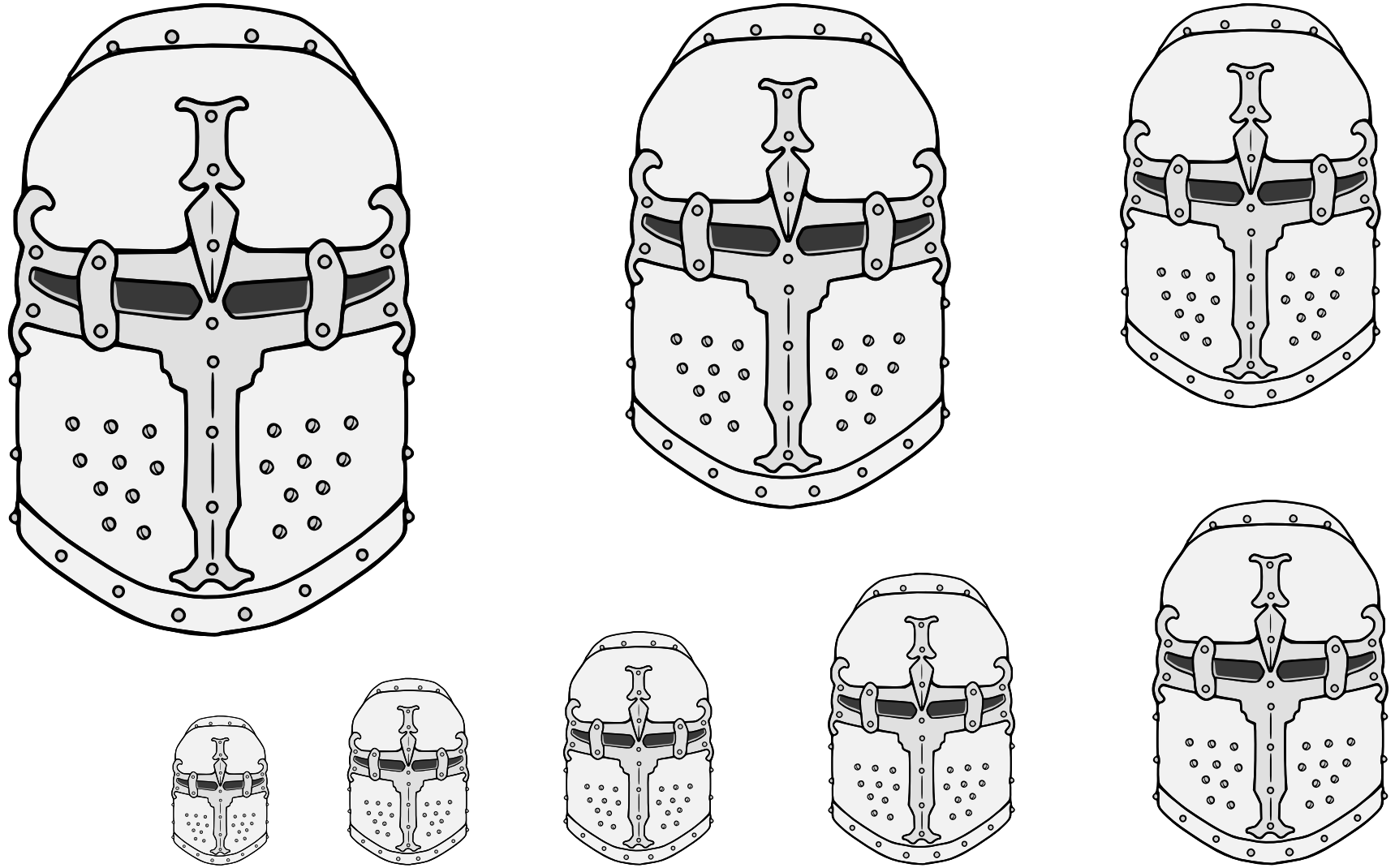

Protective armor for the head.

Default alignment: facing dexter. No proper coloration.

Artist: Jessimond of Emerickeskepe.

Helm, Great, Affronty (1) 21.149

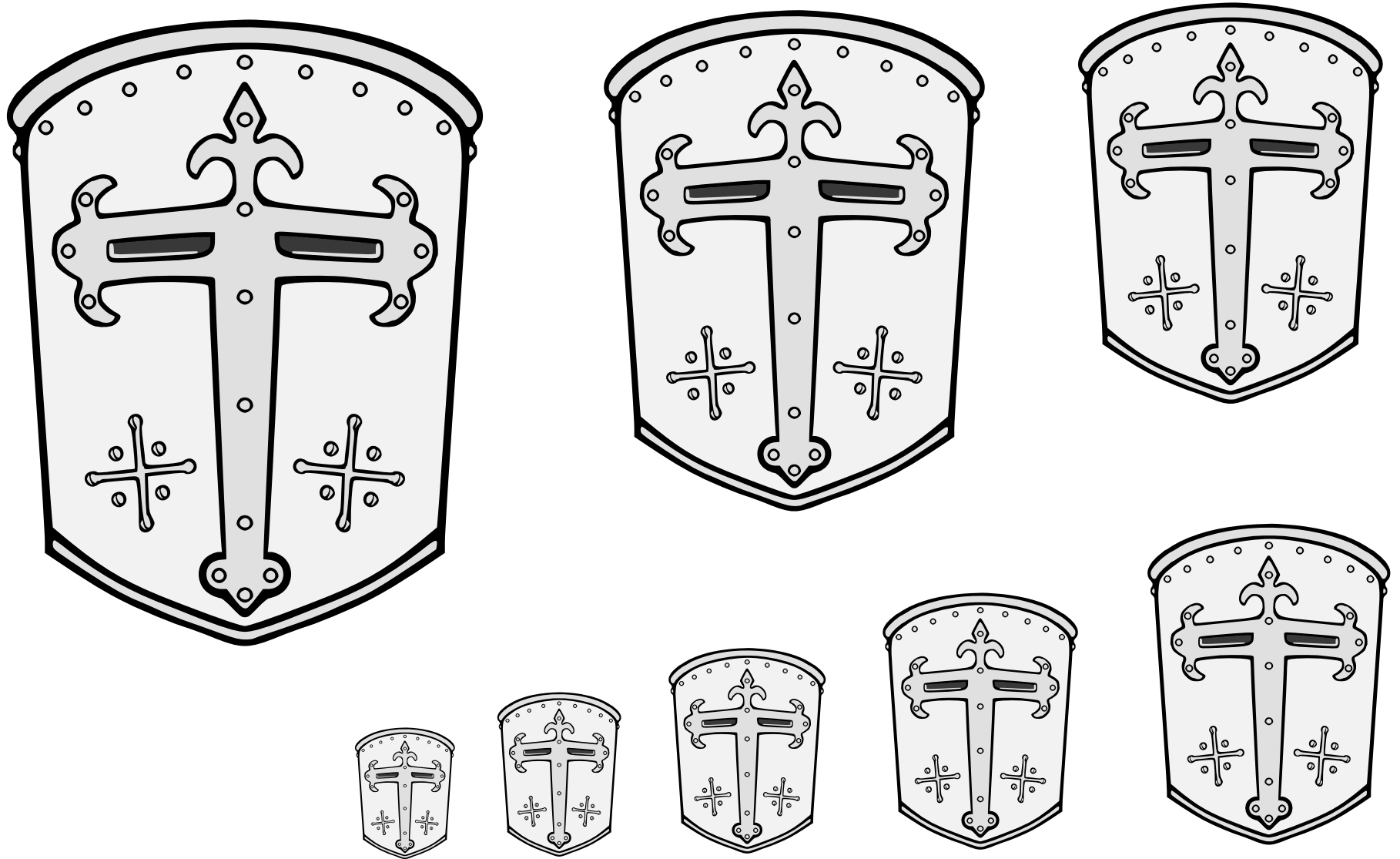

Protective armor for the head. The close helm is a sixteenth-century style.

Default orientation: facing dexter. No proper coloration.

Artist: Jessimond of Emerickeskepe.

Helm, Great, Affronty (2) 21.150

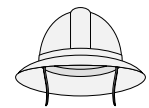
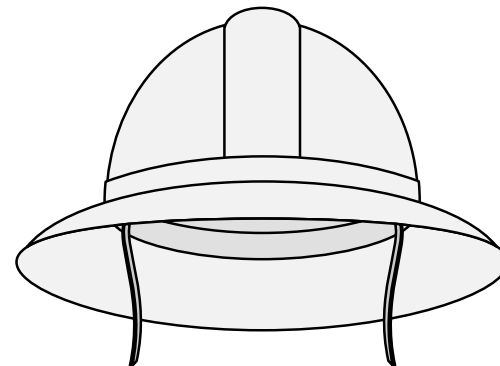
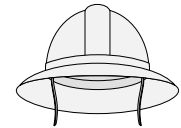
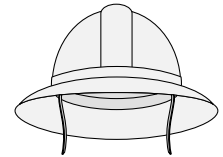
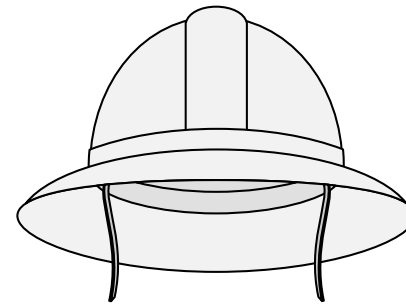
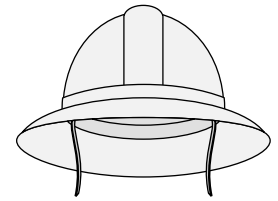
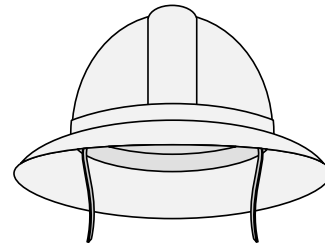
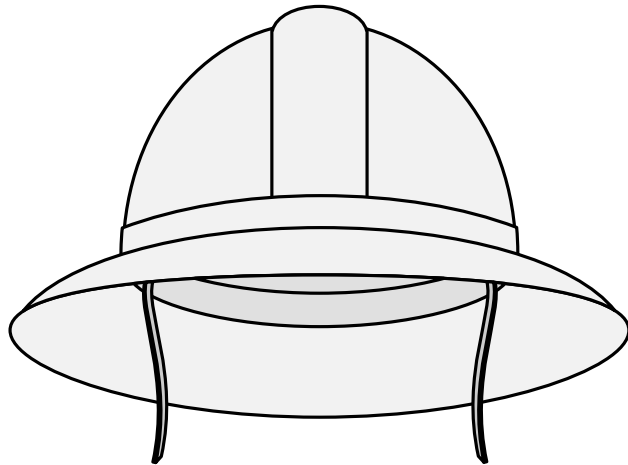
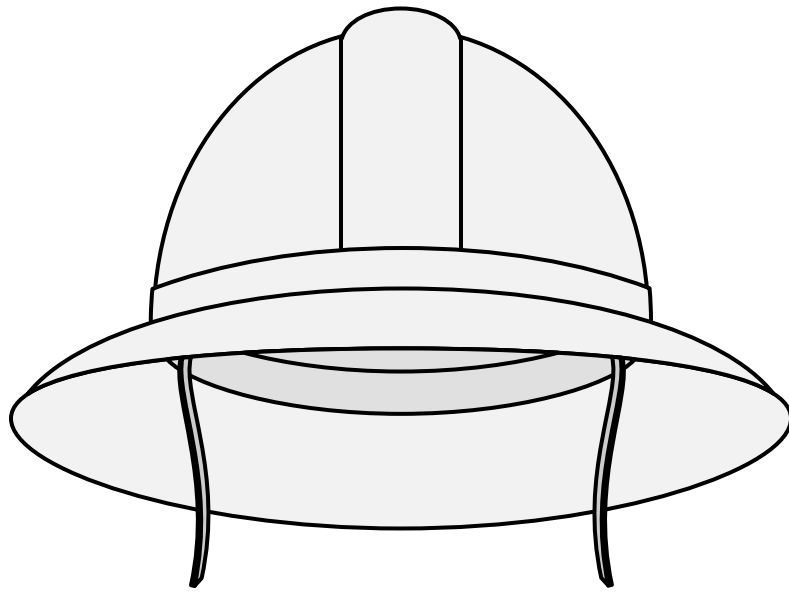

Protective armor for the head.

Default orientation: affronty. (Most helms face to dexter by default, but kettle helms are an exception.) No proper coloration.

**Helm, Kettle, Affronty** 21.151

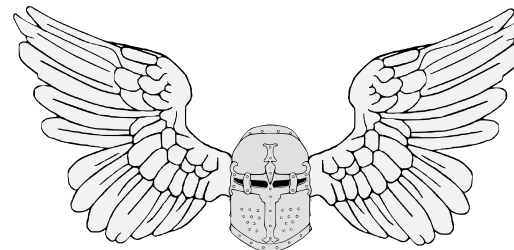
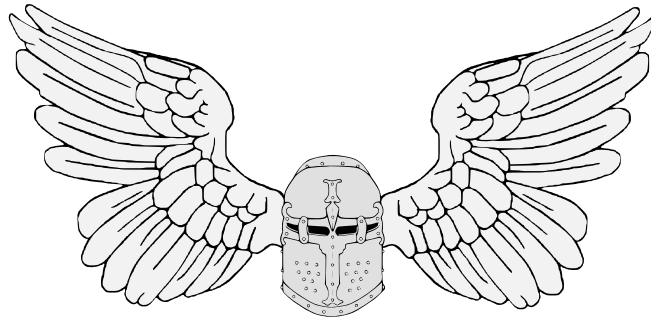
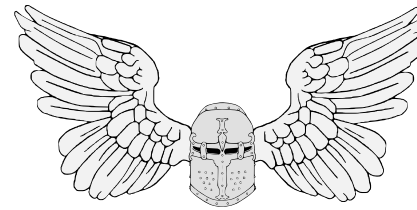
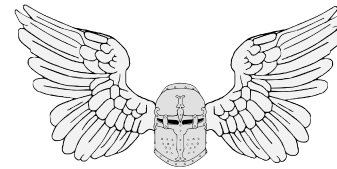
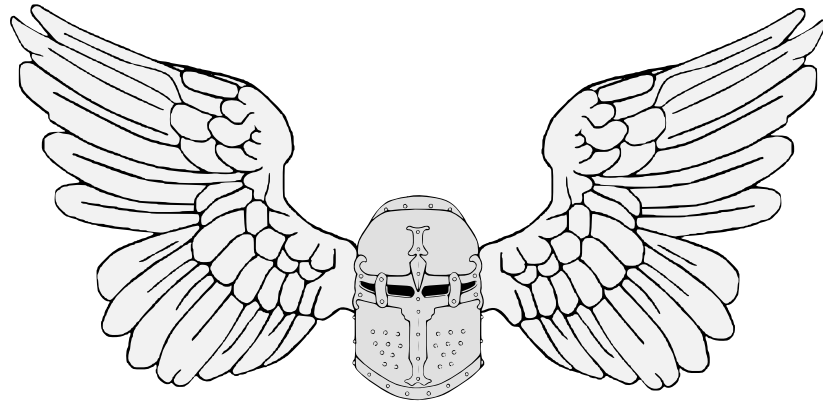

Protective armor for the head.

Default alignment: facing dexter. No proper coloration.

Artist: Jessimond of Emerickeskepe.

## Helm, Winged Great, Affronty Wings Elevated 21.152

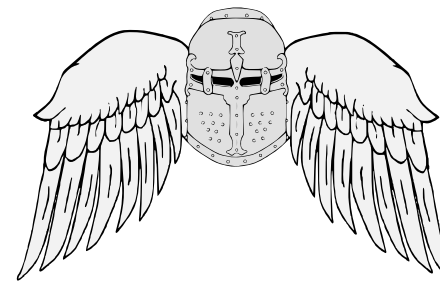
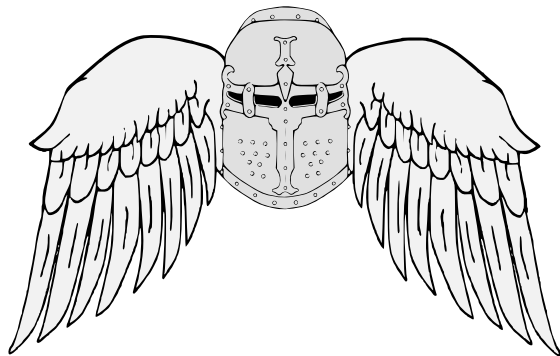
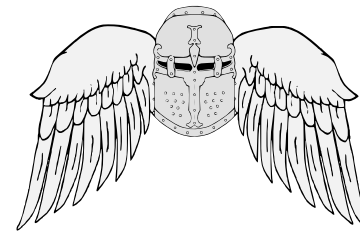
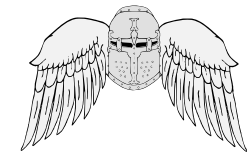
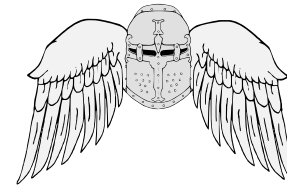
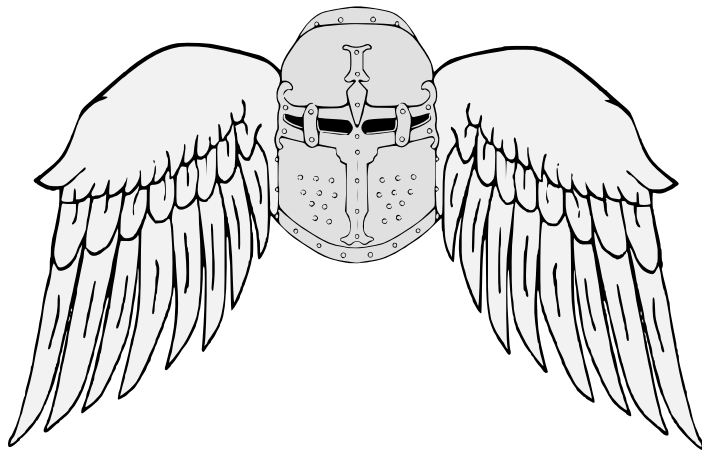

Protective armor for the head.

Default alignment: facing dexter. No proper coloration.

Artist: Jessimond of Emerickeskepe.

## Helm, Winged Great, Affronty Wings Inverted 21.153

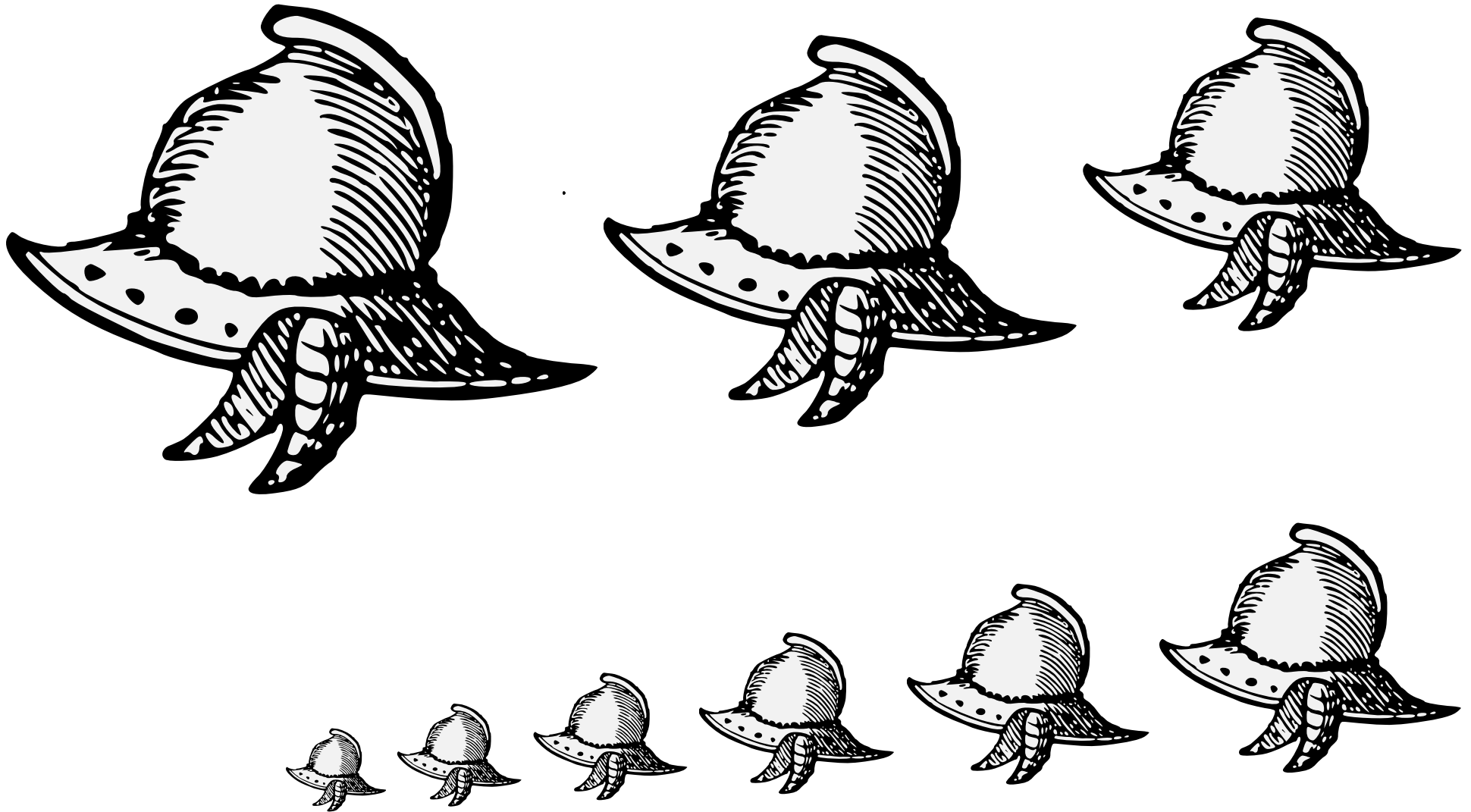

Protective armor for the head. The morion helm is a sixteenth-century Iberian style.

Default orientation: facing dexter. No proper coloration.

Source: Guillim's Display of Heraldry. Artist unknown.

Helm, Morion 21.154

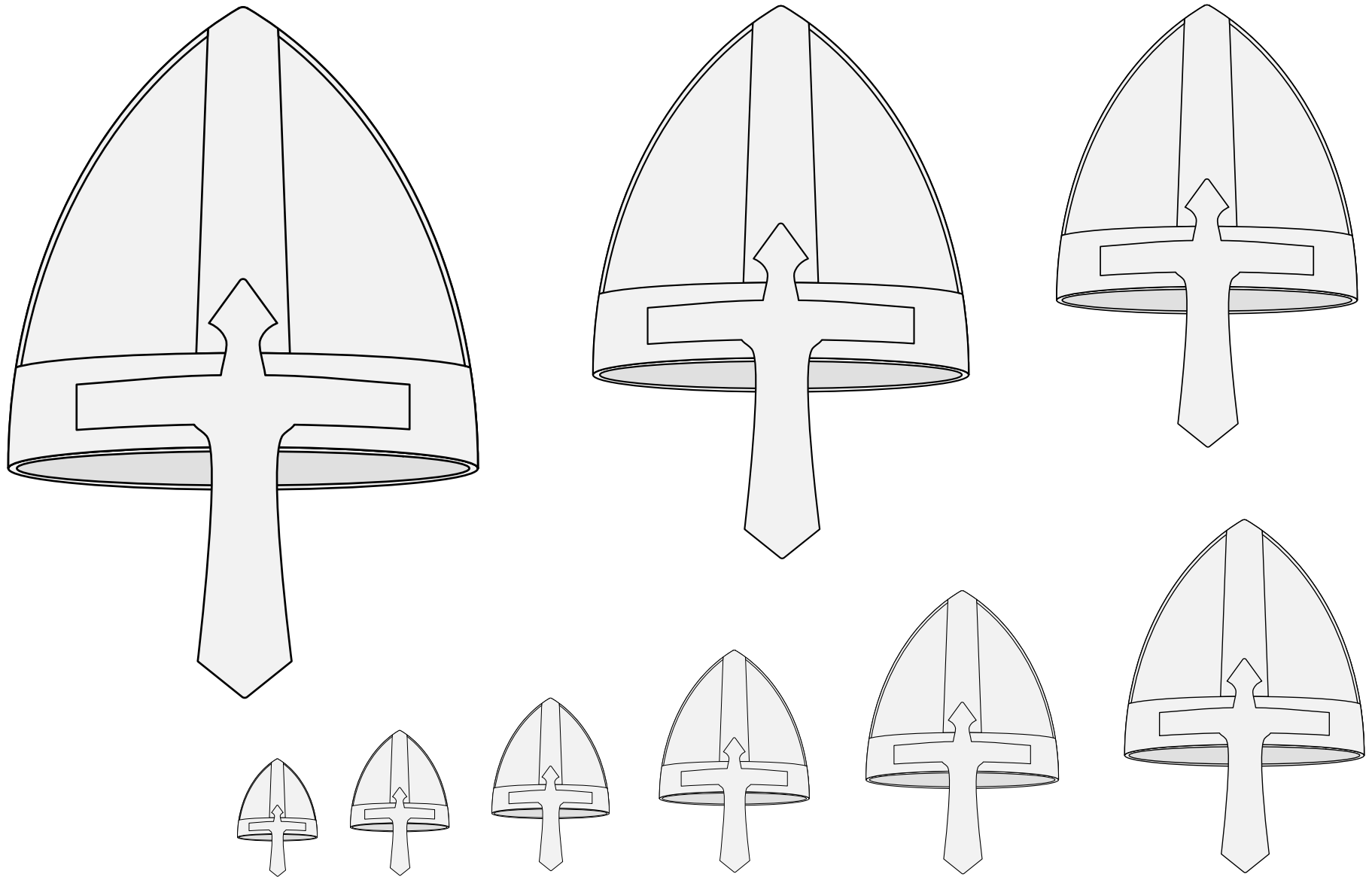

Protective armor for the head.

Default orientation: facing dexter. No proper coloration.

**Helm, Norman, Affronty • 21.155**

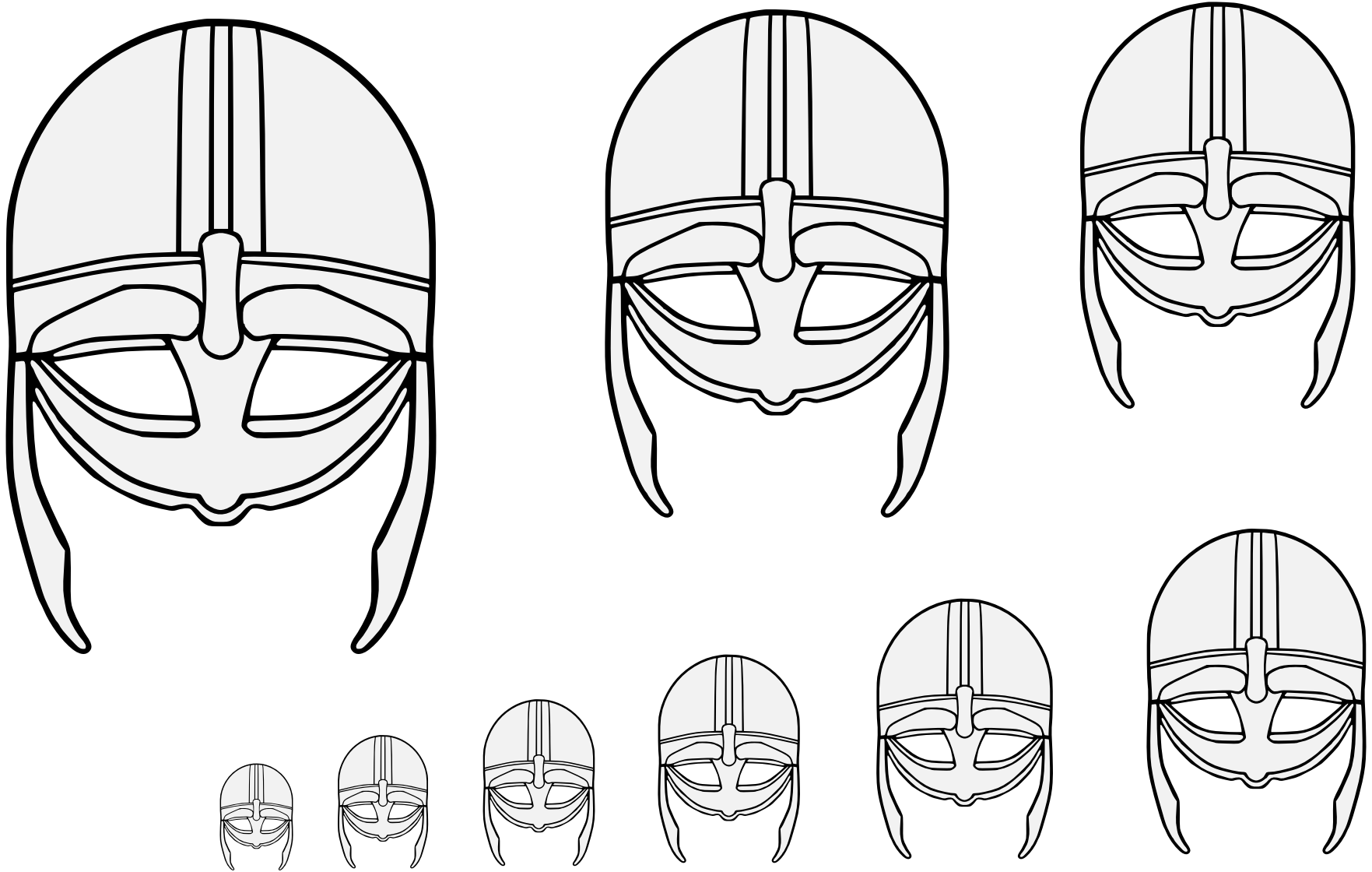

Protective armor for the head.

Default orientation: facing dexter. No proper coloration.

Artist: Jessimond of Emerickeskepe.

Helm, Ocular, Affronty 21.156



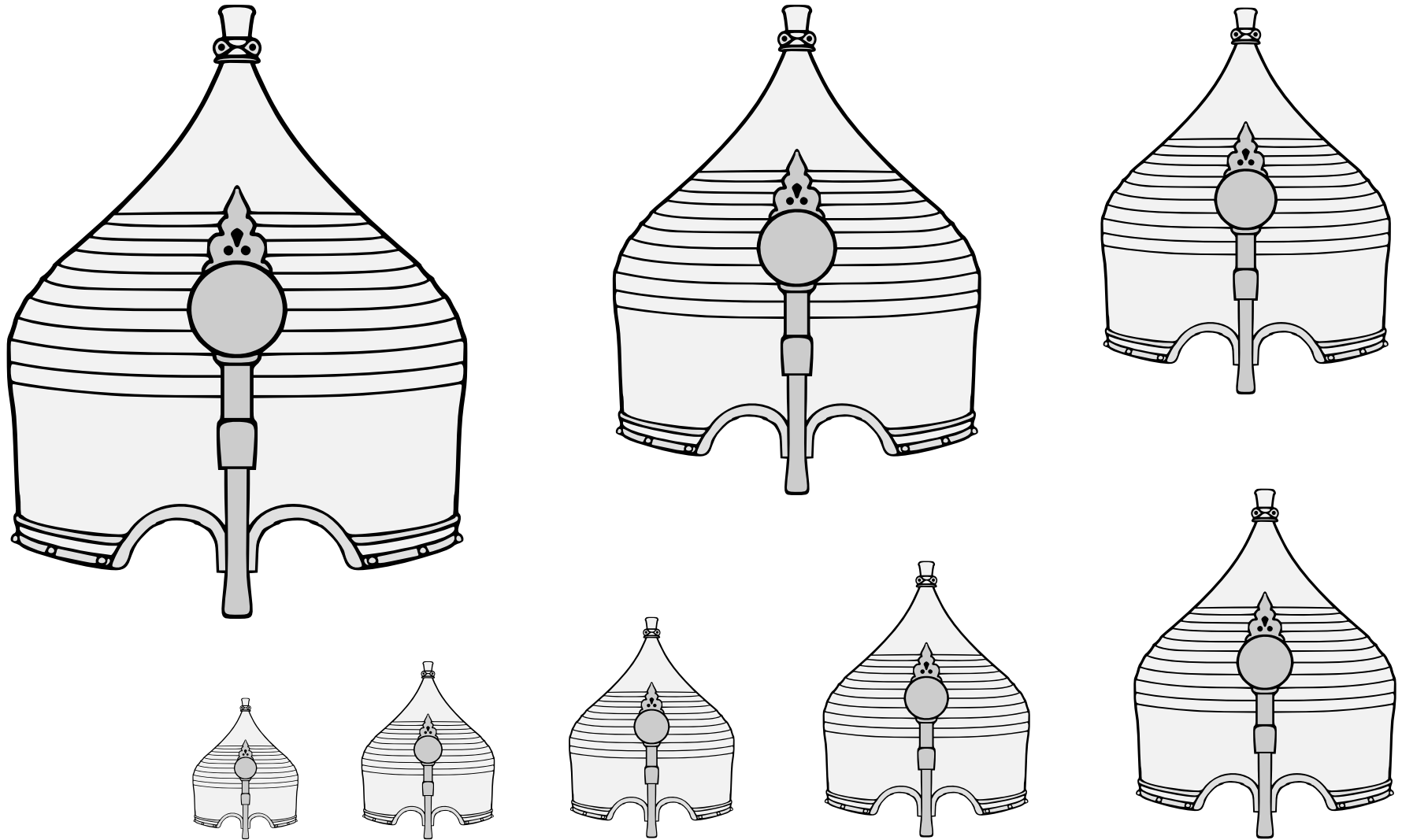

Protective armor for the head.

Default orientation: facing dexter. No proper coloration.

Artist: Jessimond of Emerickeskepe.

Adapted from a period example in the Met museum.

Helm, Turkish 🍷 21.157

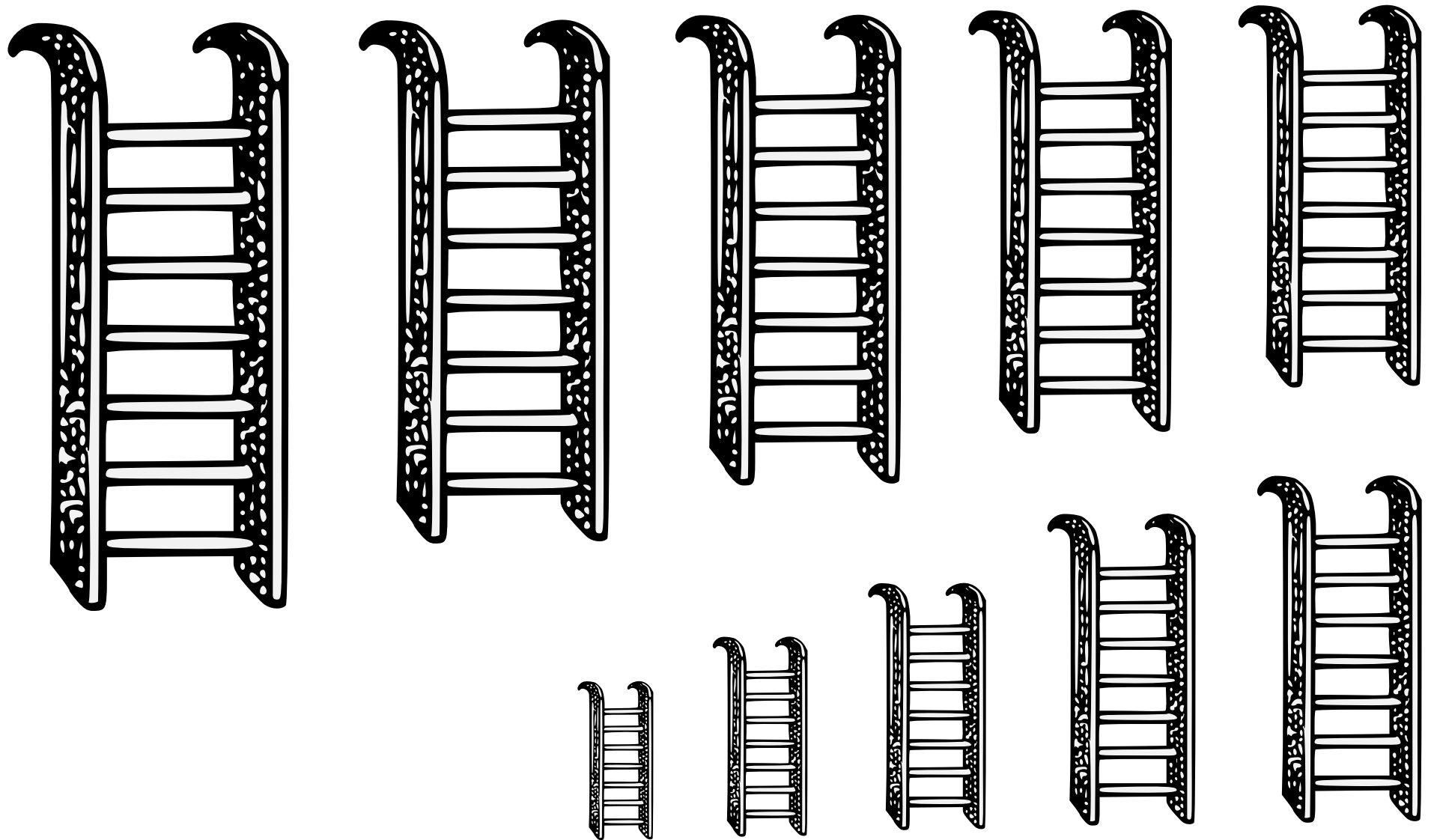

A ladder with hooks on the upper edge, used to climb defensive walls during war.

Default orientation: palewise, hooks to chief. No proper coloration.

Source: A Complete Guide to Heraldry. Artist: Graham Johnston.

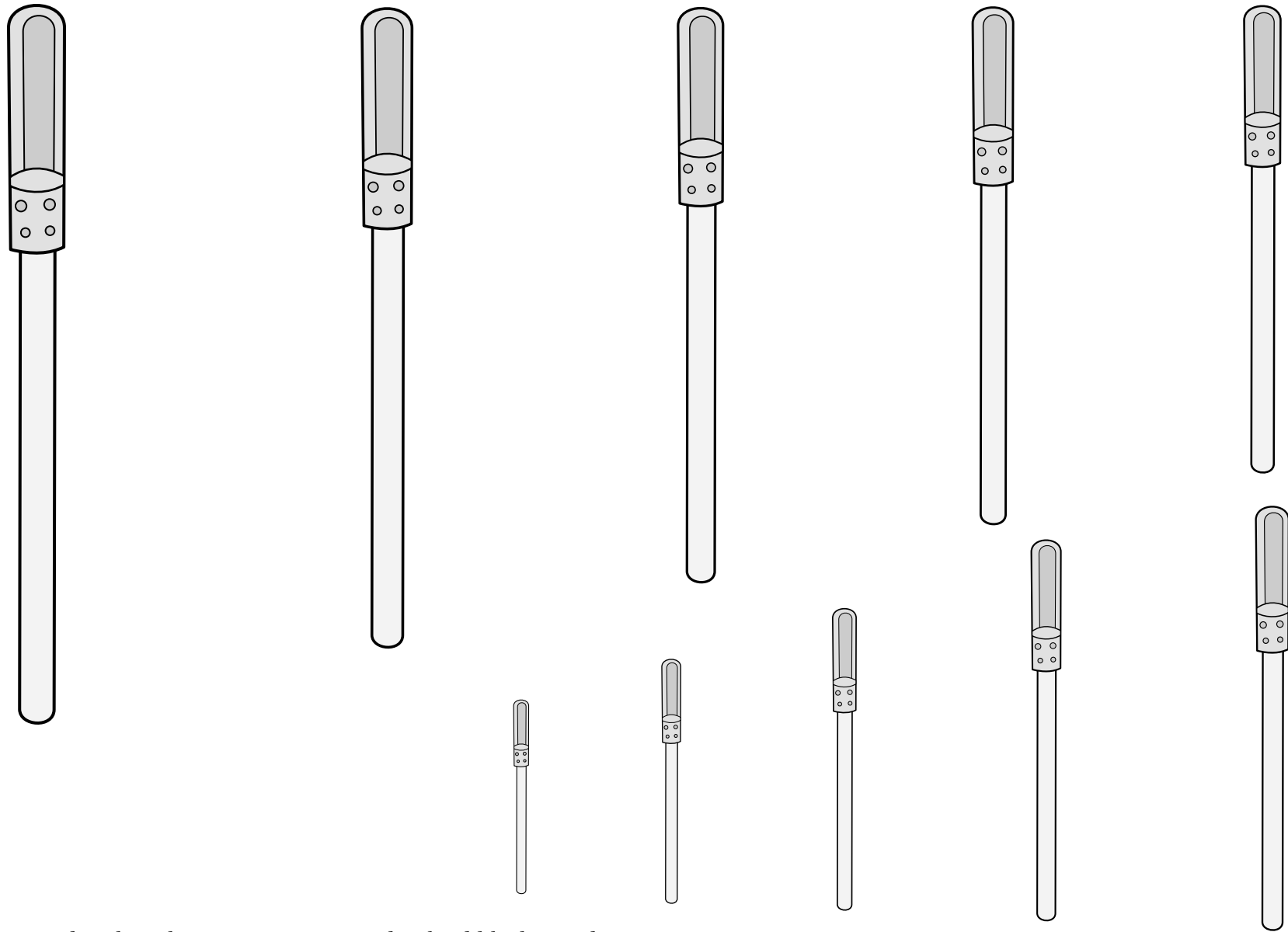

A long staff capped with with a copper scoop used to load black powder into a cannon.

Default orientation: scoop to chief. No proper coloration.

Source: A Display of Heraldry. Artist: John Guillim.  
(Manuscript folio 95r.) Adapted by Iago ab Adam.

Ladle, Artillery 21.159

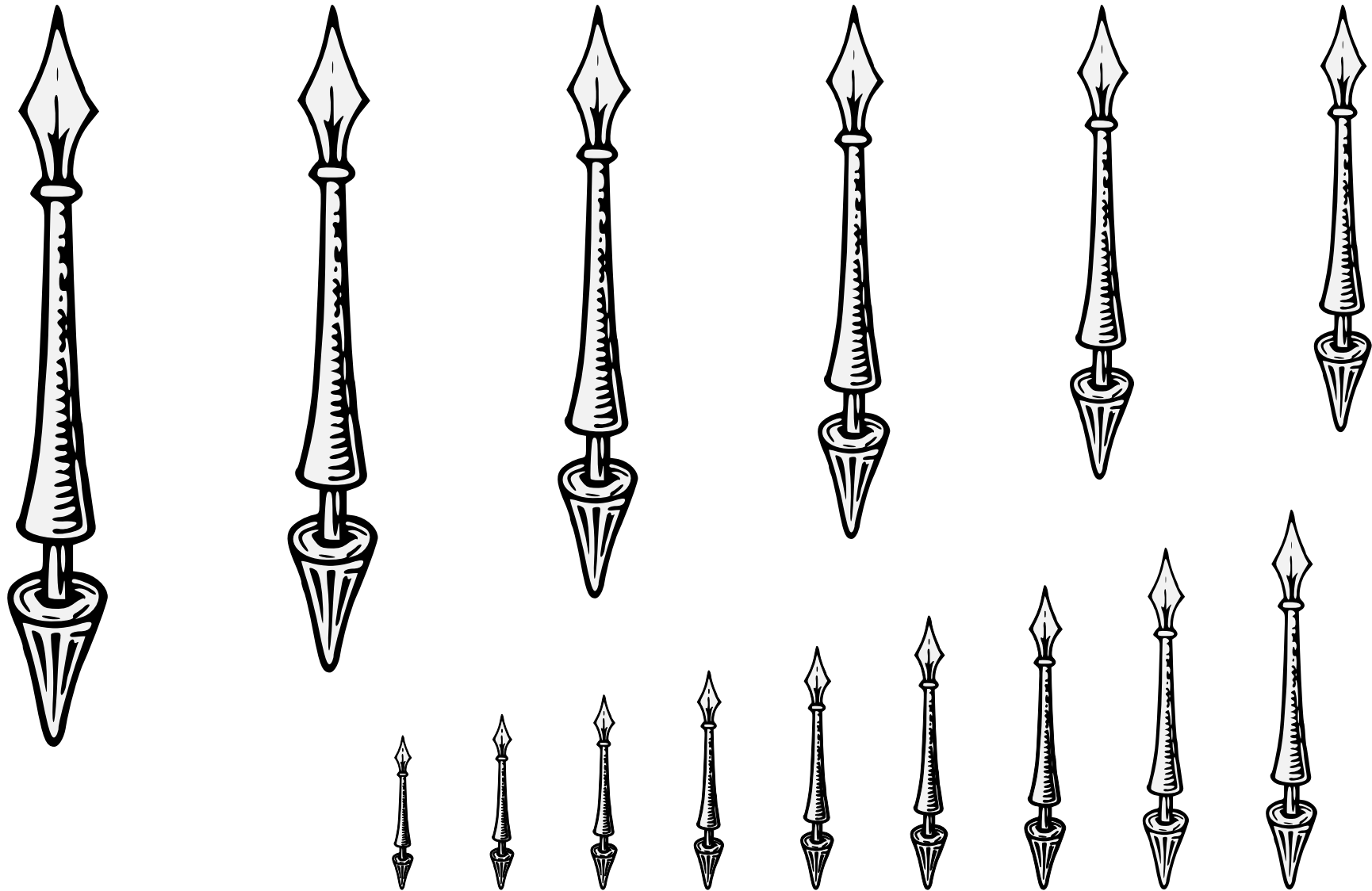

A solid wooden shaft used for jousting. May also be blazoned a "tilting spear."

Default orientation: point to chief. No proper coloration.

Source: A Complete Guide to Heraldry.

Artist: Graham Johnston.

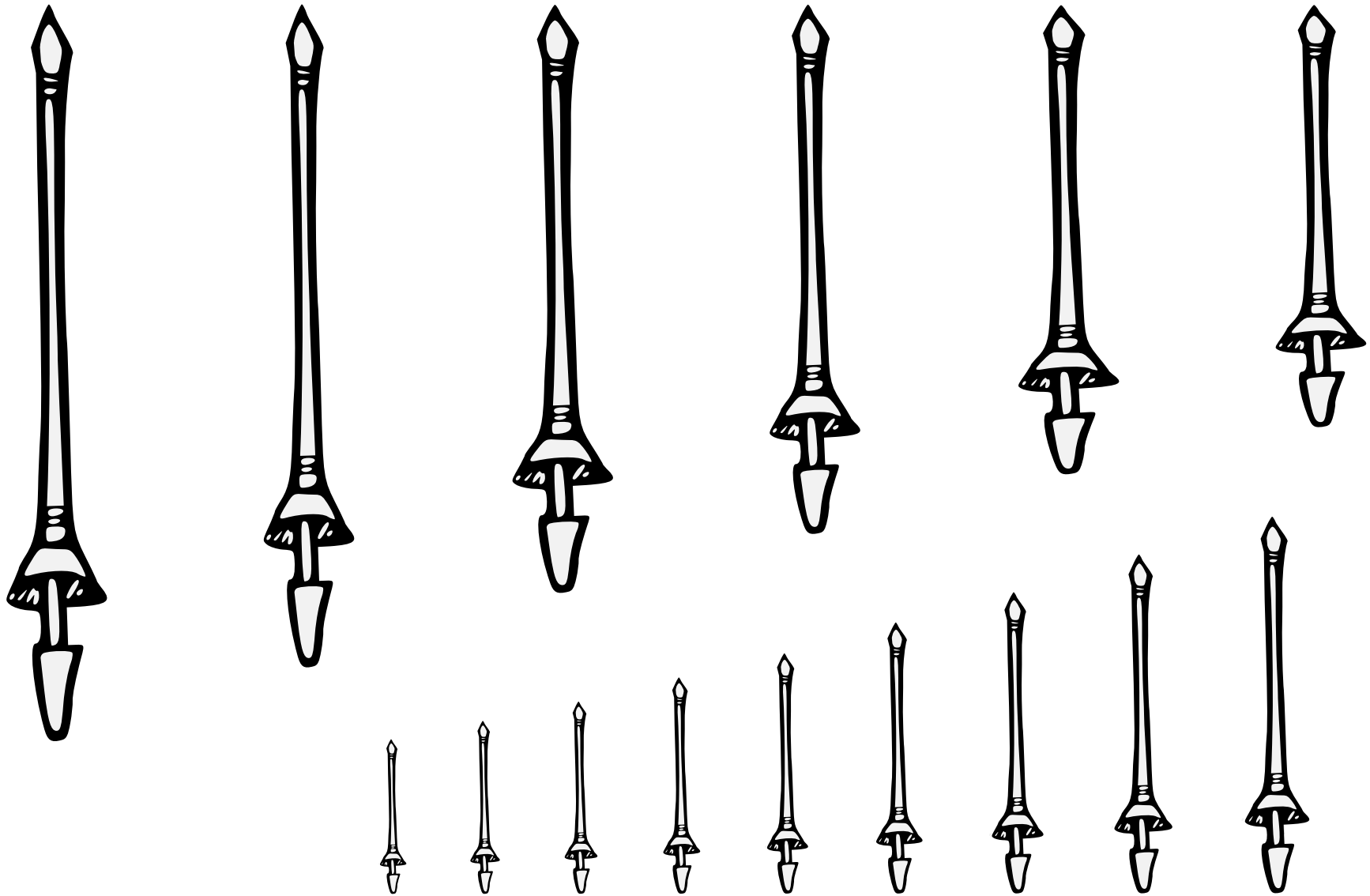

A solid wooden shaft used for jousting. May also be blazoned a "tilting spear."

Default orientation: point to chief. No proper coloration.

Source: Workes of Armorie. Artist: John Bossewell.

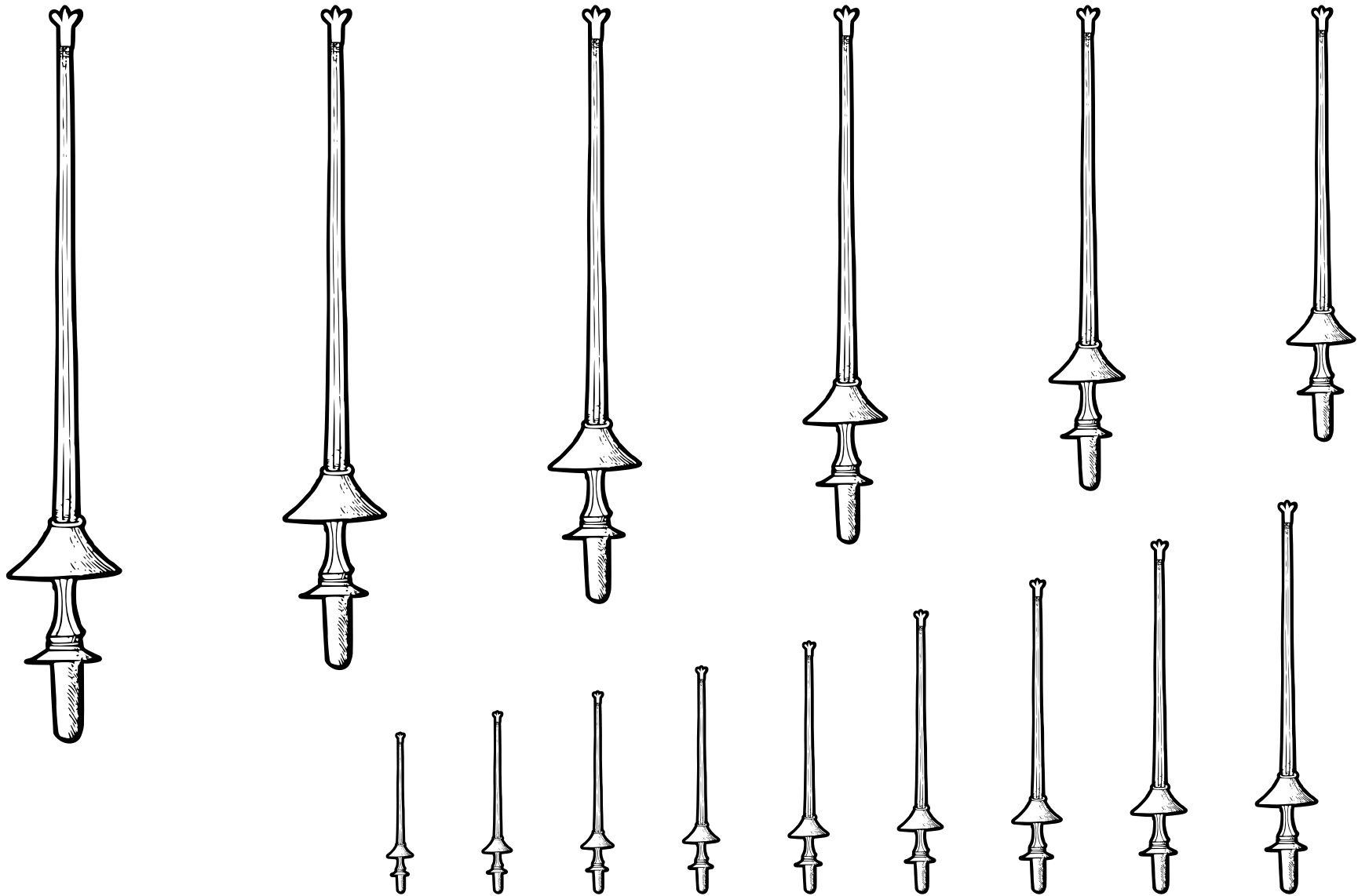

A solid wooden shaft used for jousting. May also be blazoned a "tilting spear."

Default orientation: point to chief. No proper coloration.

Source: Guillim's Display of Heraldry. Artist unknown.

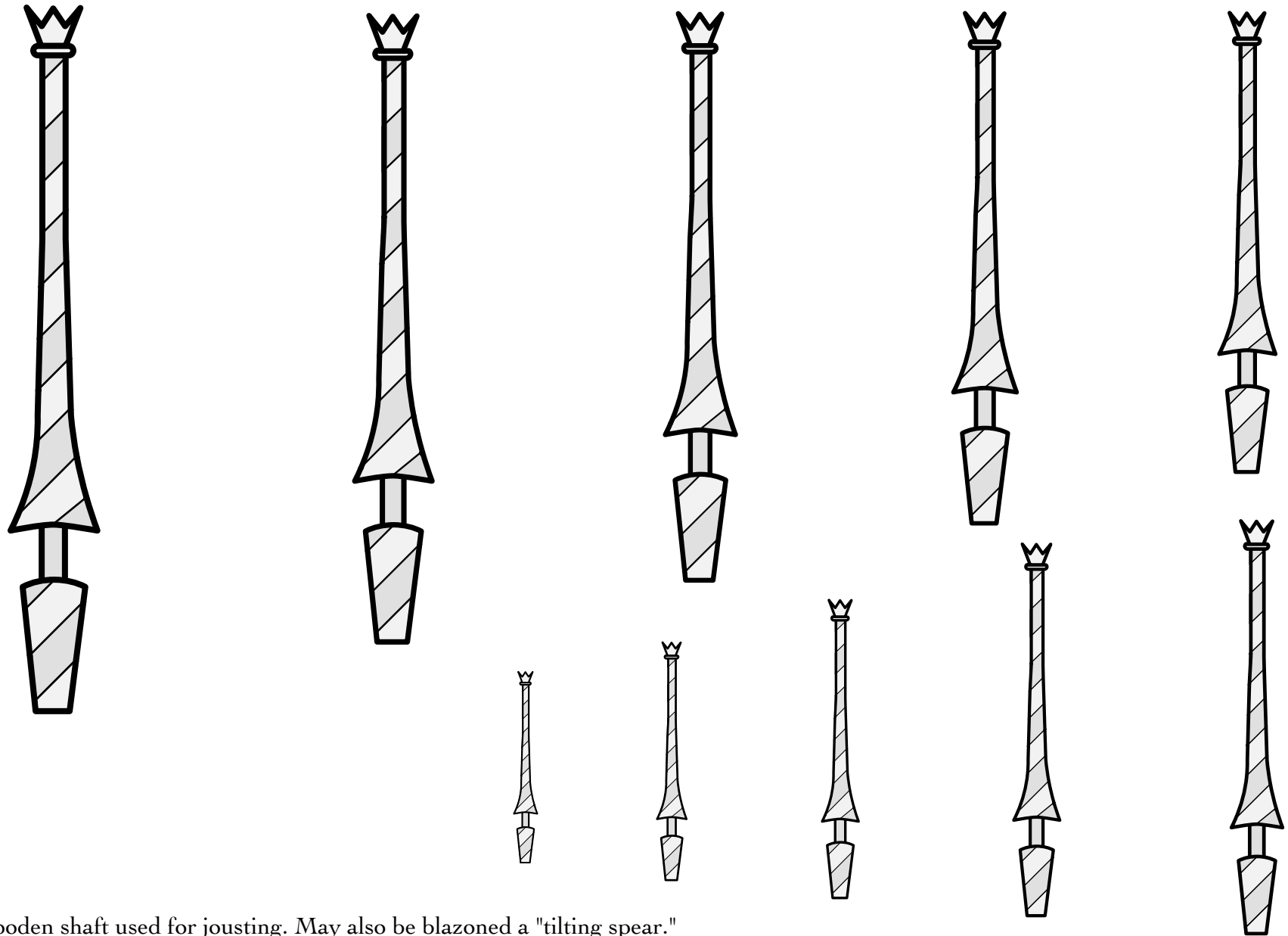

A solid wooden shaft used for jousting. May also be blazoned a "tilting spear."

Default orientation: point to chief. No proper coloration.

Source: Viking Answer Lady SVG Images For Heraldry.

Artist: Gunnvôr silfrahárr.

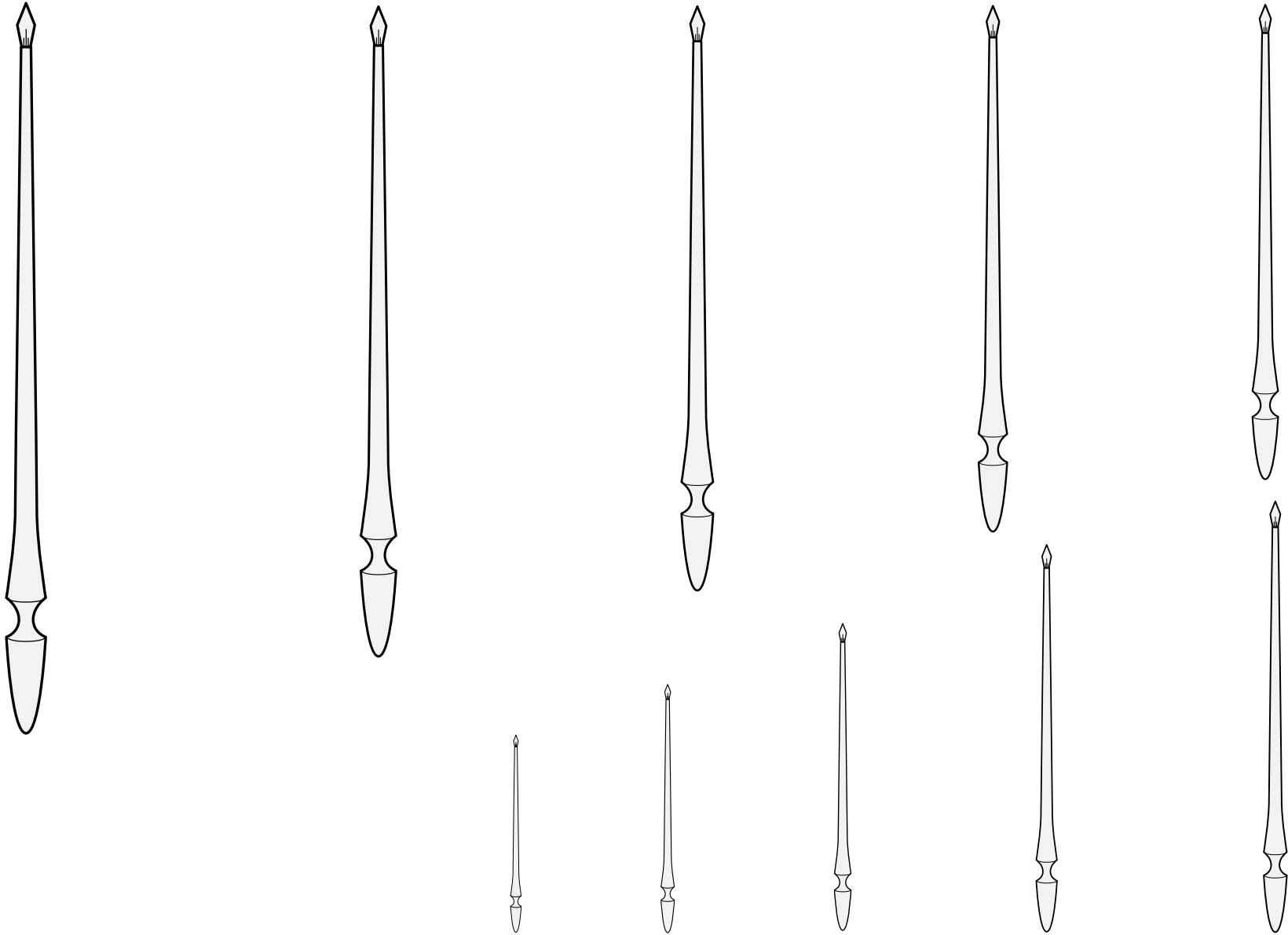

A solid wooden shaft used for jousting. May also be blazoned a "tilting spear."

Default orientation: point to chief. No proper coloration.

Source: Confréries de la Cour Amoureuse. Artist unknown.



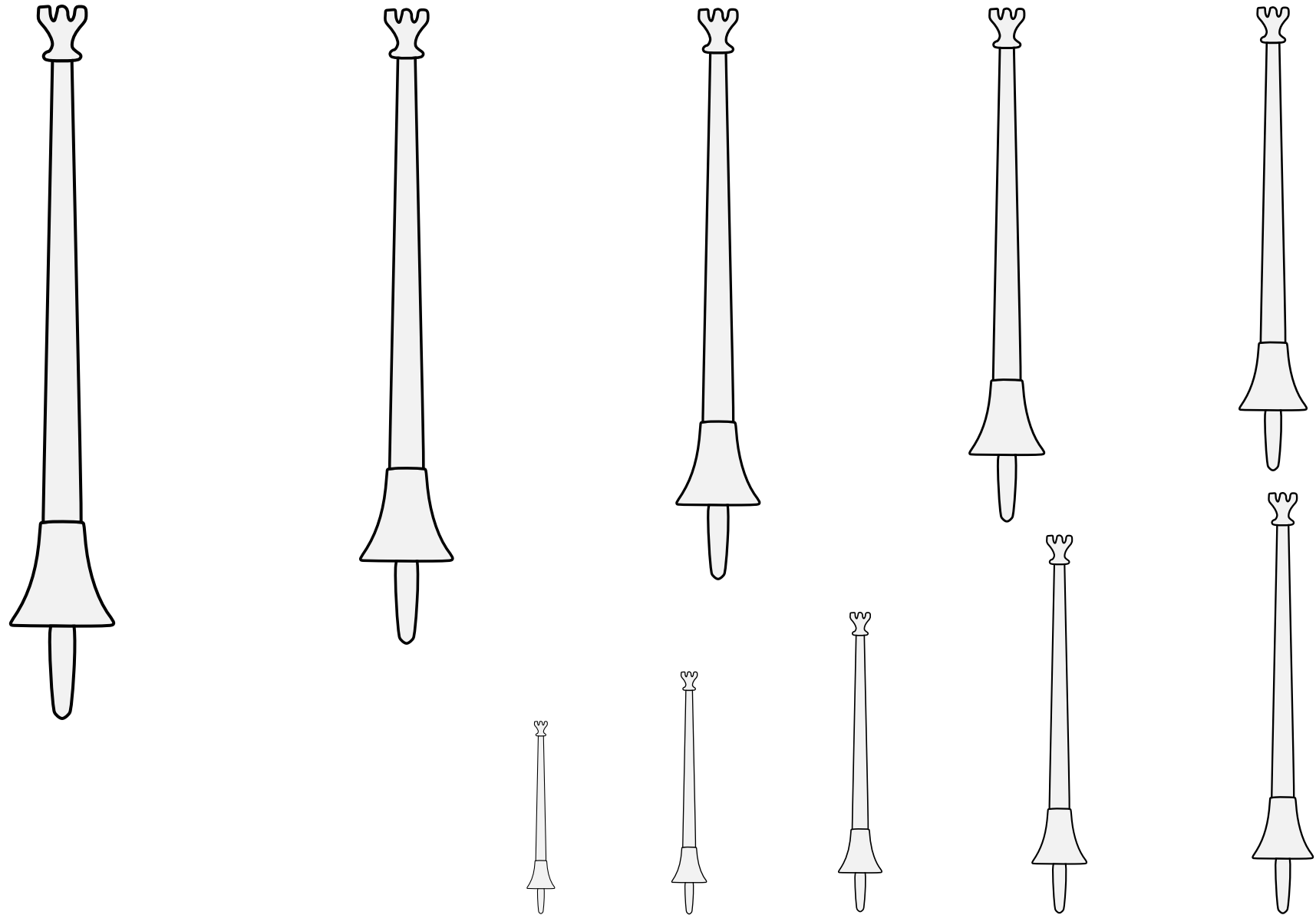

A solid wooden shaft used for jousting. May also be blazoned a "tilting spear."

Default orientation: point to chief. No proper coloration.

Source: Sledgehammer. Artist: Grimwulf Harland.

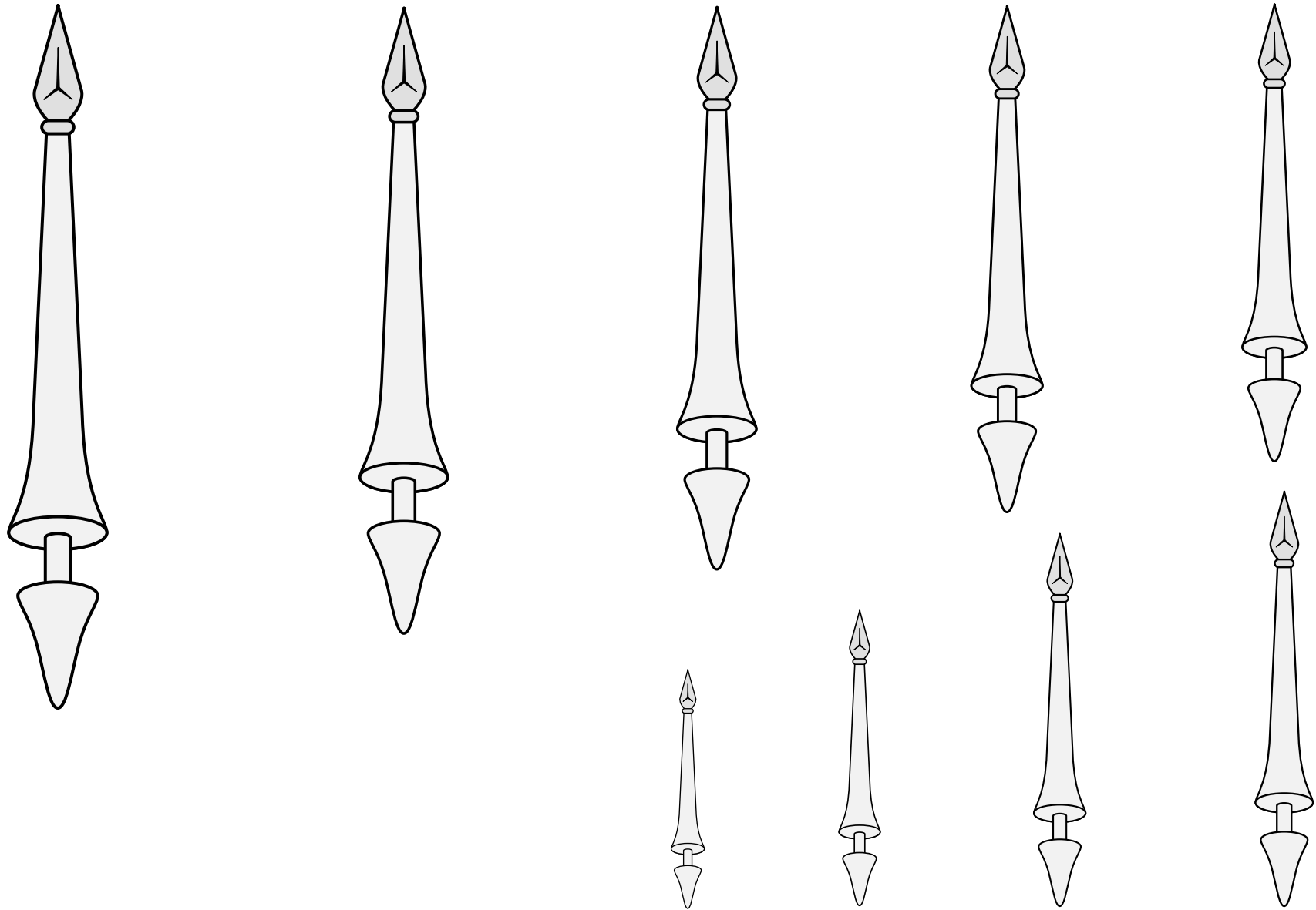

A solid wooden shaft used for jousting. May also be blazoned a "tilting spear."

Default orientation: point to chief. No proper coloration.

Source: WappenWiki. Artist: Joakim Spuller.

Lance (7) 21.166

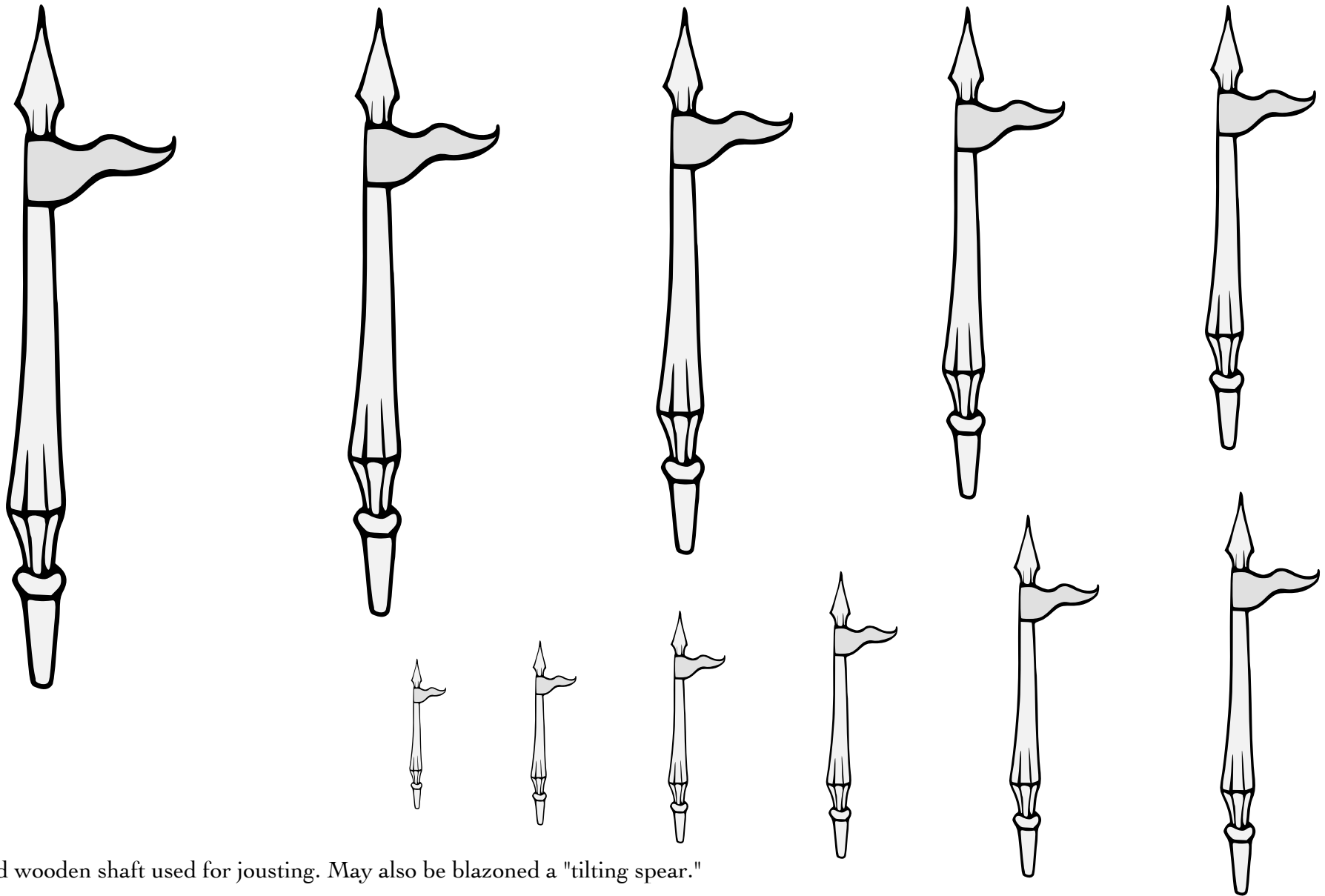

A solid wooden shaft used for jousting. May also be blazoned a "tilting spear."

Default orientation: point to chief. No proper coloration.

Source: Two Tudor Books of Arms.  
Artist: Robert Cooke. (From page 25,  
arms of Schorthose of Yorkechyre.)

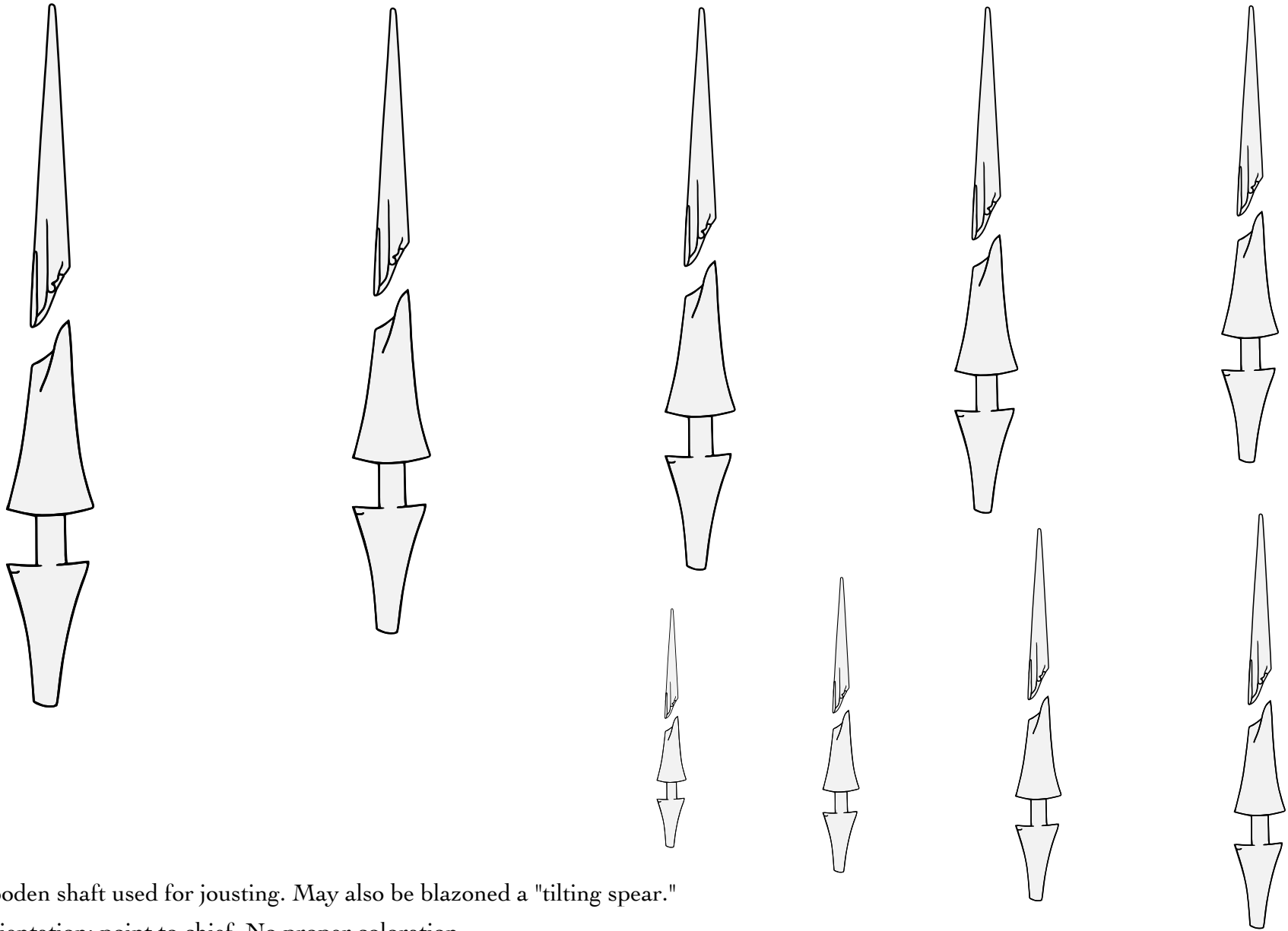

A solid wooden shaft used for jousting. May also be blazoned a "tilting spear."

Default orientation: point to chief. No proper coloration.

Source: Araldo Nel Quale si Vedono Delineate e Colorite le  
Armi de' Potentati e Sovrani d'Europa. Artist unknown.  
(Arms of Aenobardi, folio 63r.) Adapted by Sneferu ex Artemisias.

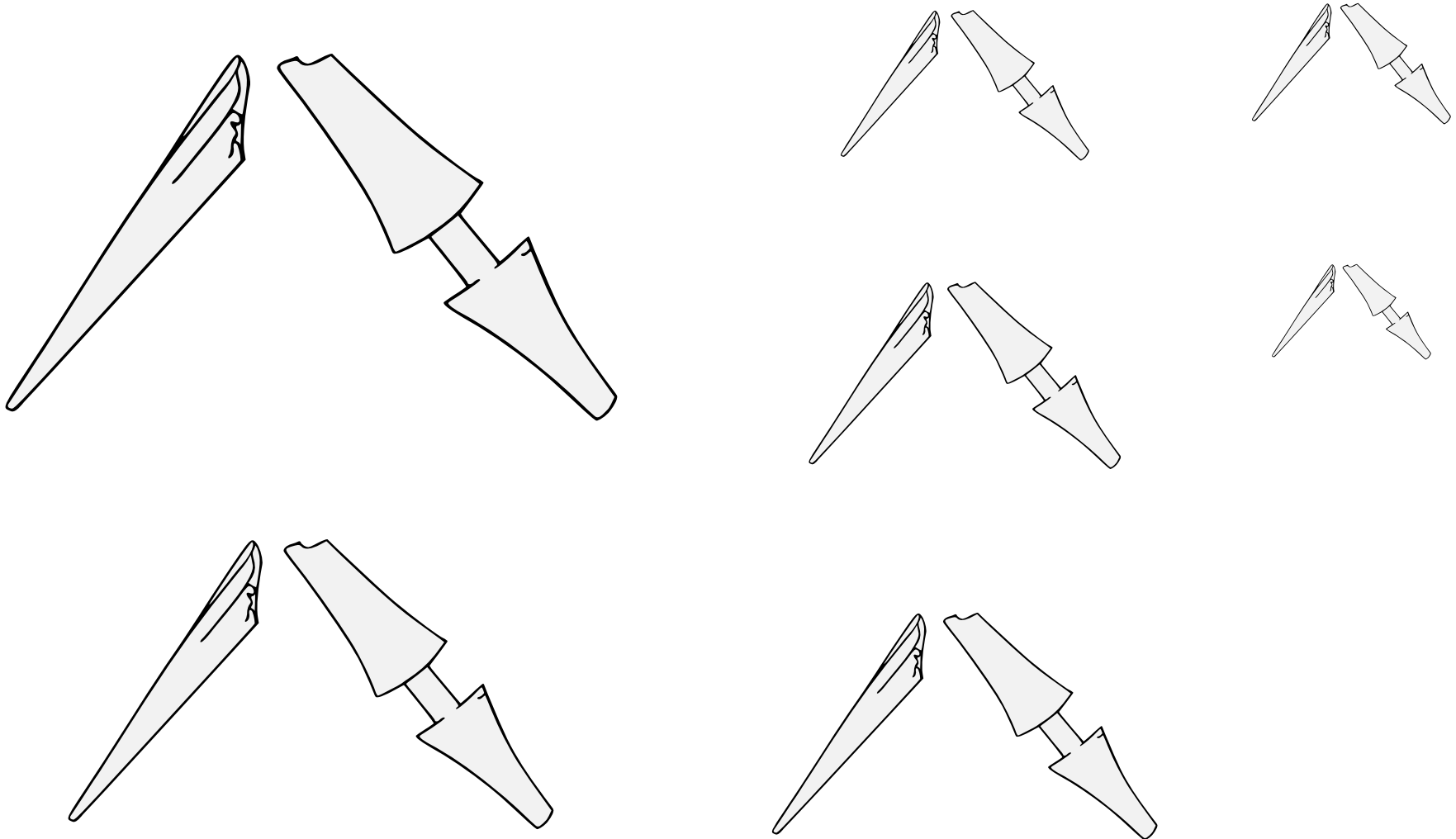

A solid wooden shaft used for jousting. May also be blazoned a "tilting spear."

Default orientation: point to chief. No proper coloration.

Source: Araldo Nel Quale si Vedono Delineate e Colorite le Armi de' Potentati e Sovrani d'Europa. Artist unknown.

(Arms of Aenobardi, folio 63r.)

Adapted by Sneferu ex Artemisias.

Lance Fracted in Chevron • 21.169

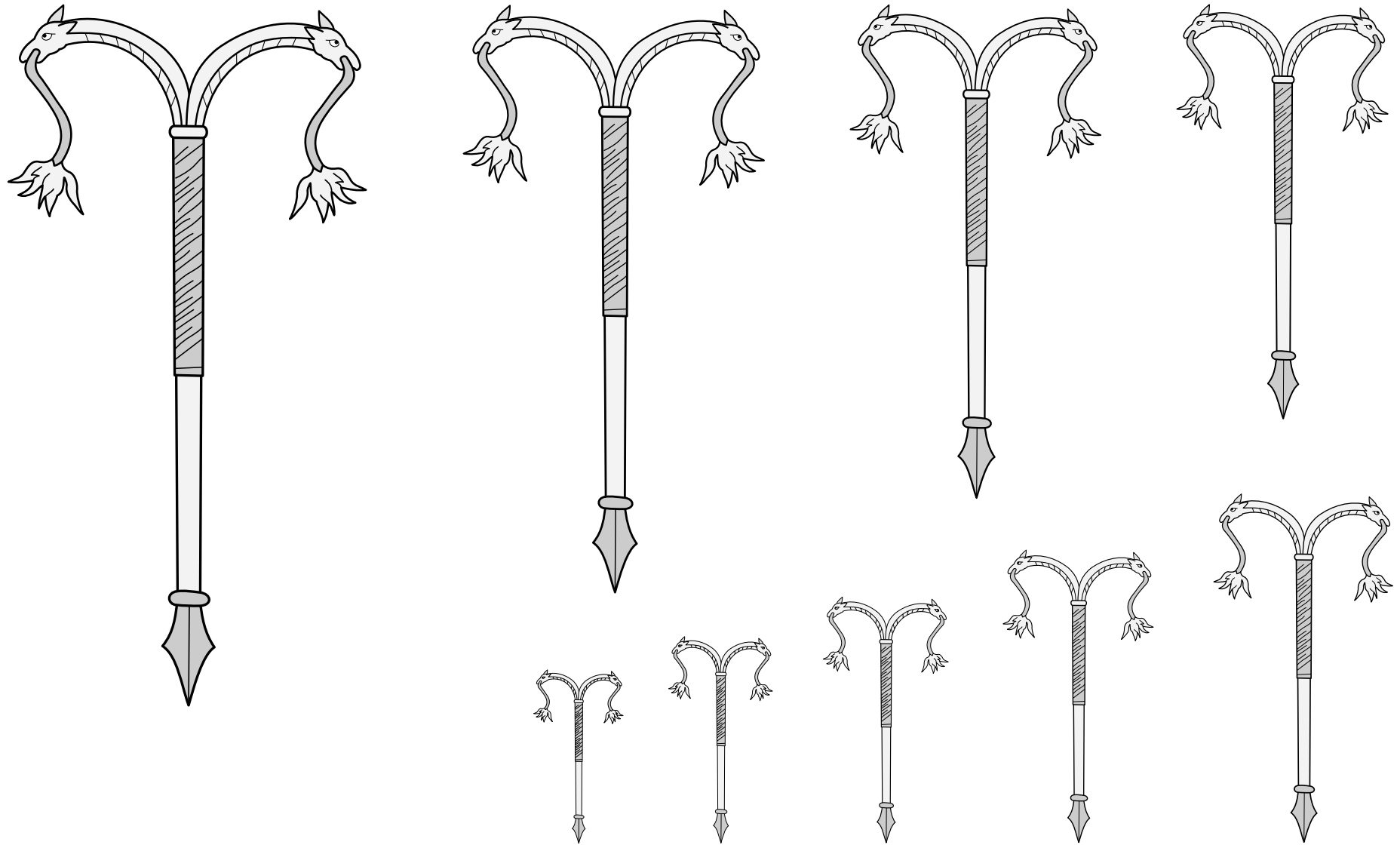

A long staff capped with serpentine arms that grip lit matches used to fire a cannon.

Default orientation: matches to chief. No proper coloration.

Source: Beschreibung des Büchsen-schießens in Innsbruck vom Jahr 1569.  
Artist unknown. (Page 60.) Adapted by Iago ab Adam.

Linstock • 21.170

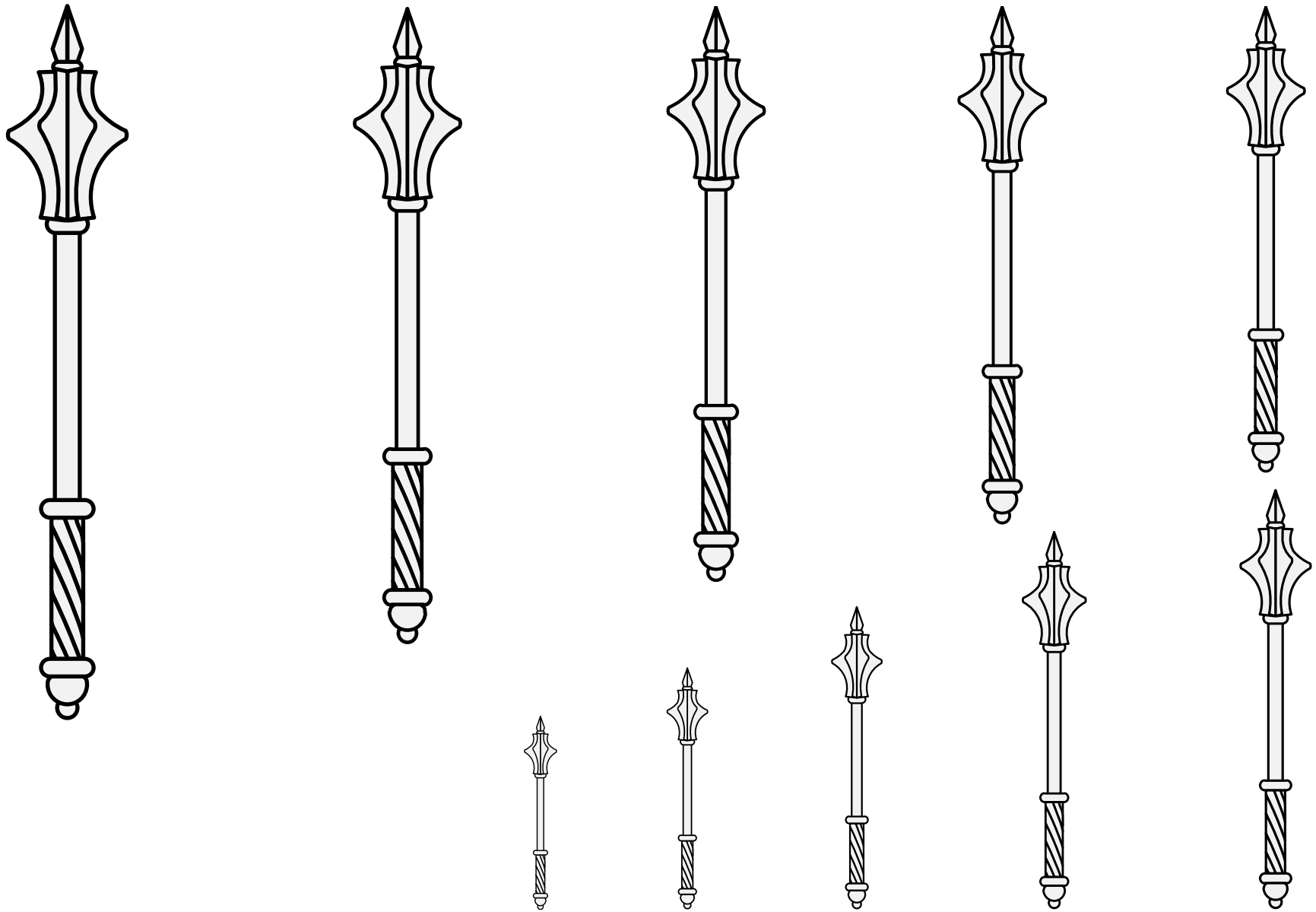

A fearsome weapon.

Default orientation: hilt to base. No proper coloration.

Source: Viking Answer Lady SVG Images For Heraldry.

Artist: Gunnvôr silfrhárr.

Mace, Flanged (1) 21.171

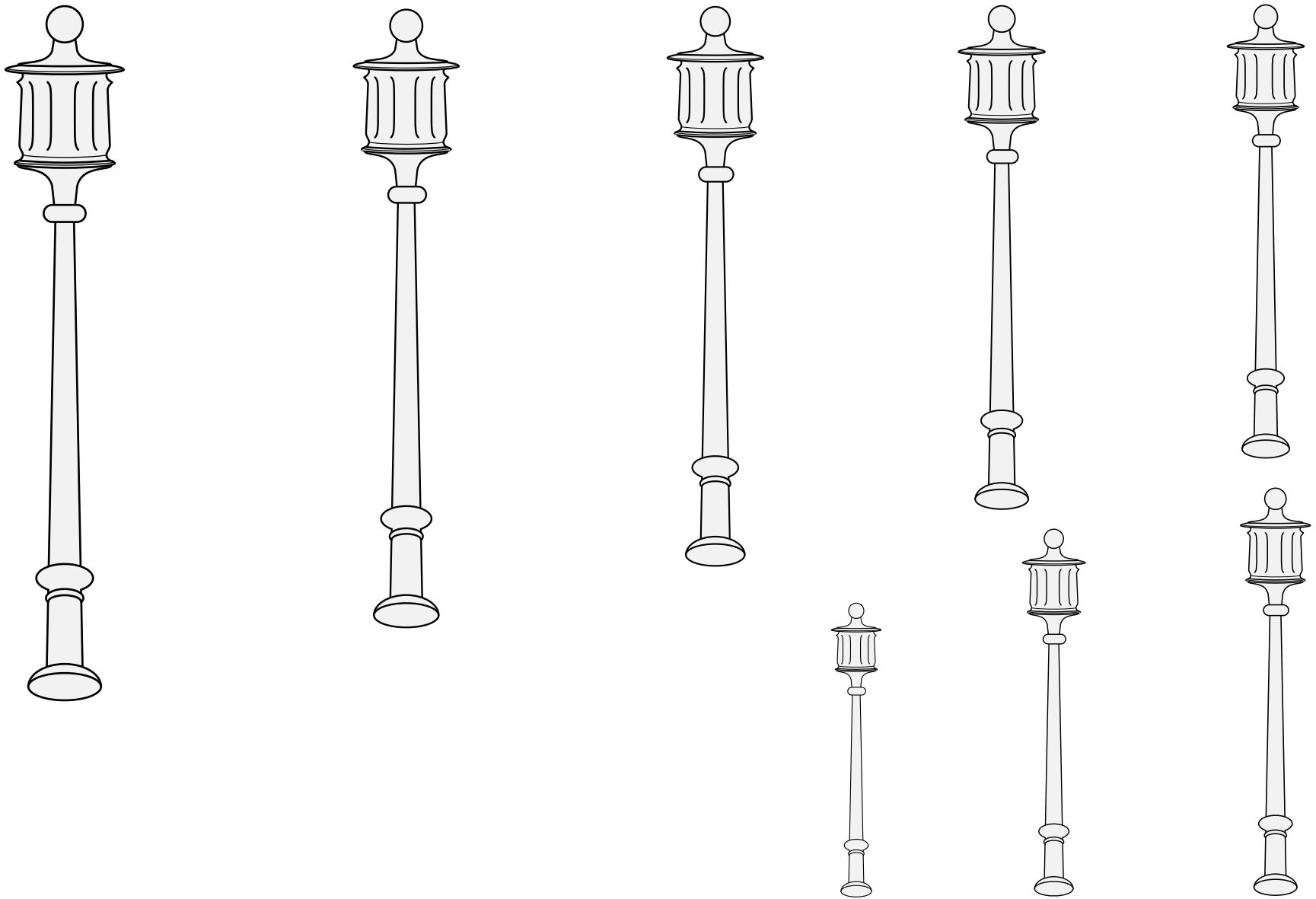

A fearsome weapon.

Default orientation: hilt to base. No proper coloration.

Source: Insignia Florentinorum. Artist unknown. (From the arms of Lamberteschi, fol. 82.) Adapted by Mathghamhain Ua Ruadháin.

Mace, Flanged (2) 21.172



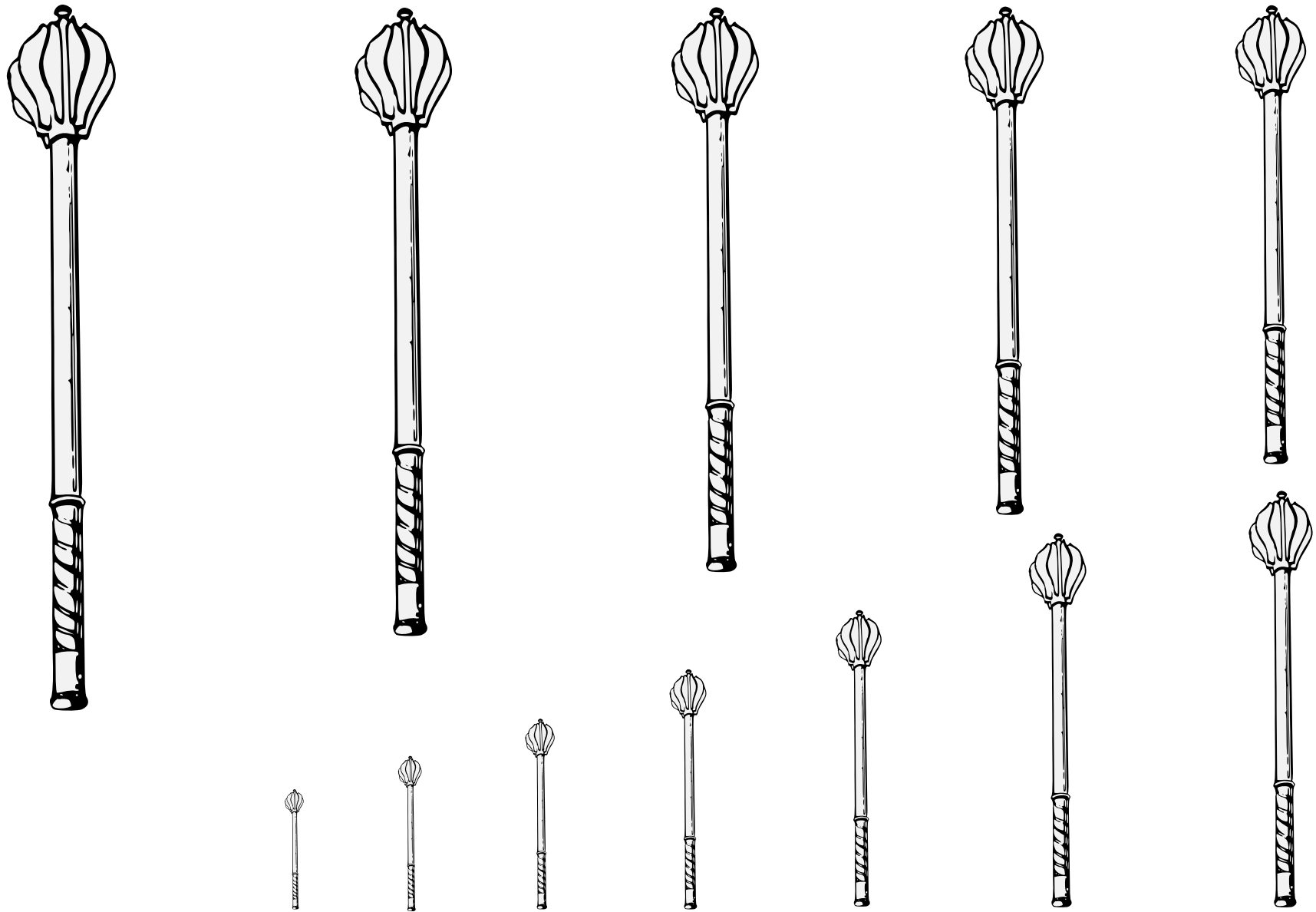

A fearsome weapon.

Default orientation: hilt to base. No proper coloration.

Source: A Cyclopedia of Costume. Artist unknown. (Volume I, page 344.)

Mace, Flanged (3) 21.173

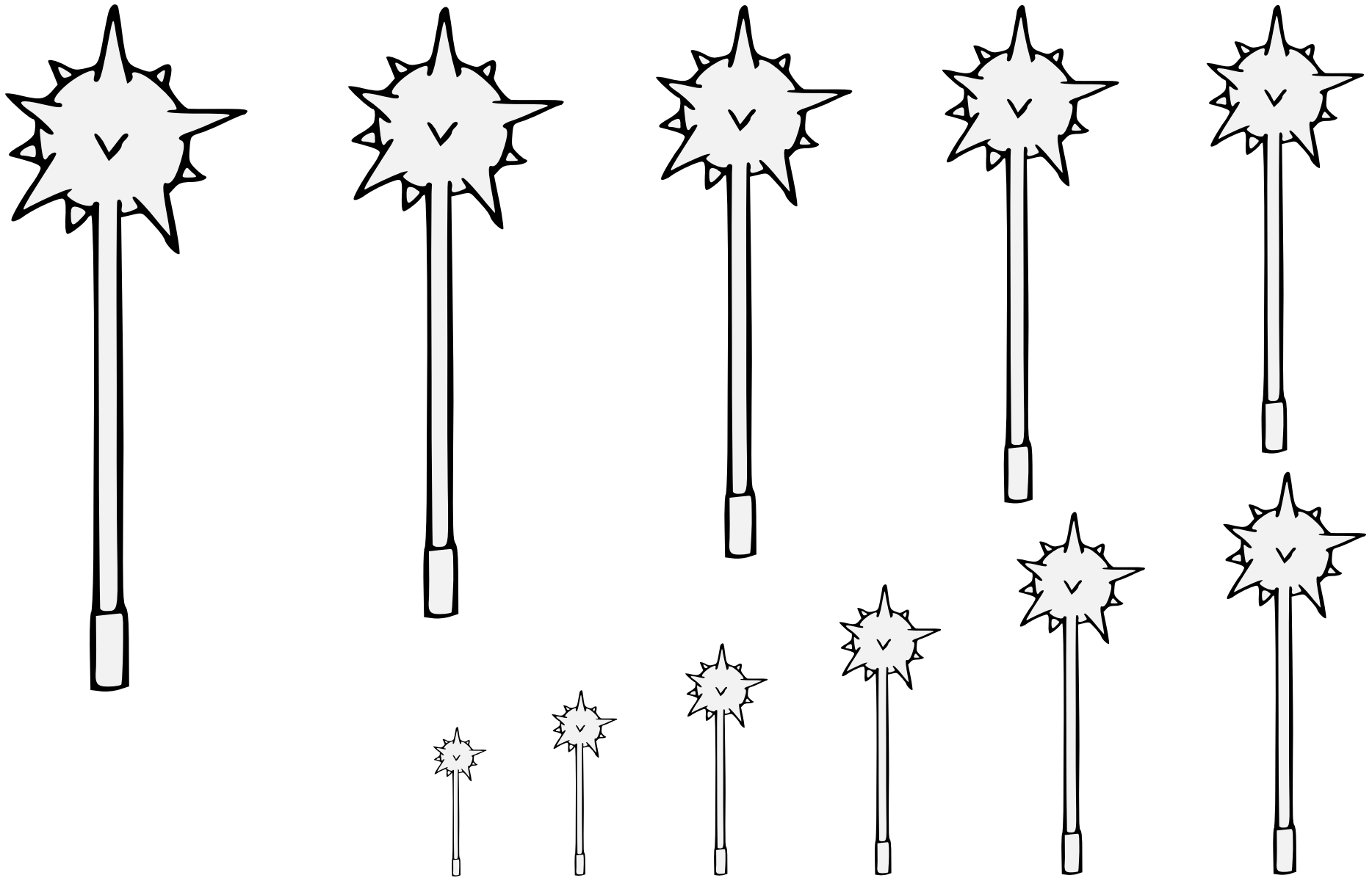

A fearsome weapon.

Default orientation: hilt to base. No proper coloration.

Source: Pennsic Traceable Art. Artist unknown.

Mace, Spiked (1) 21.174

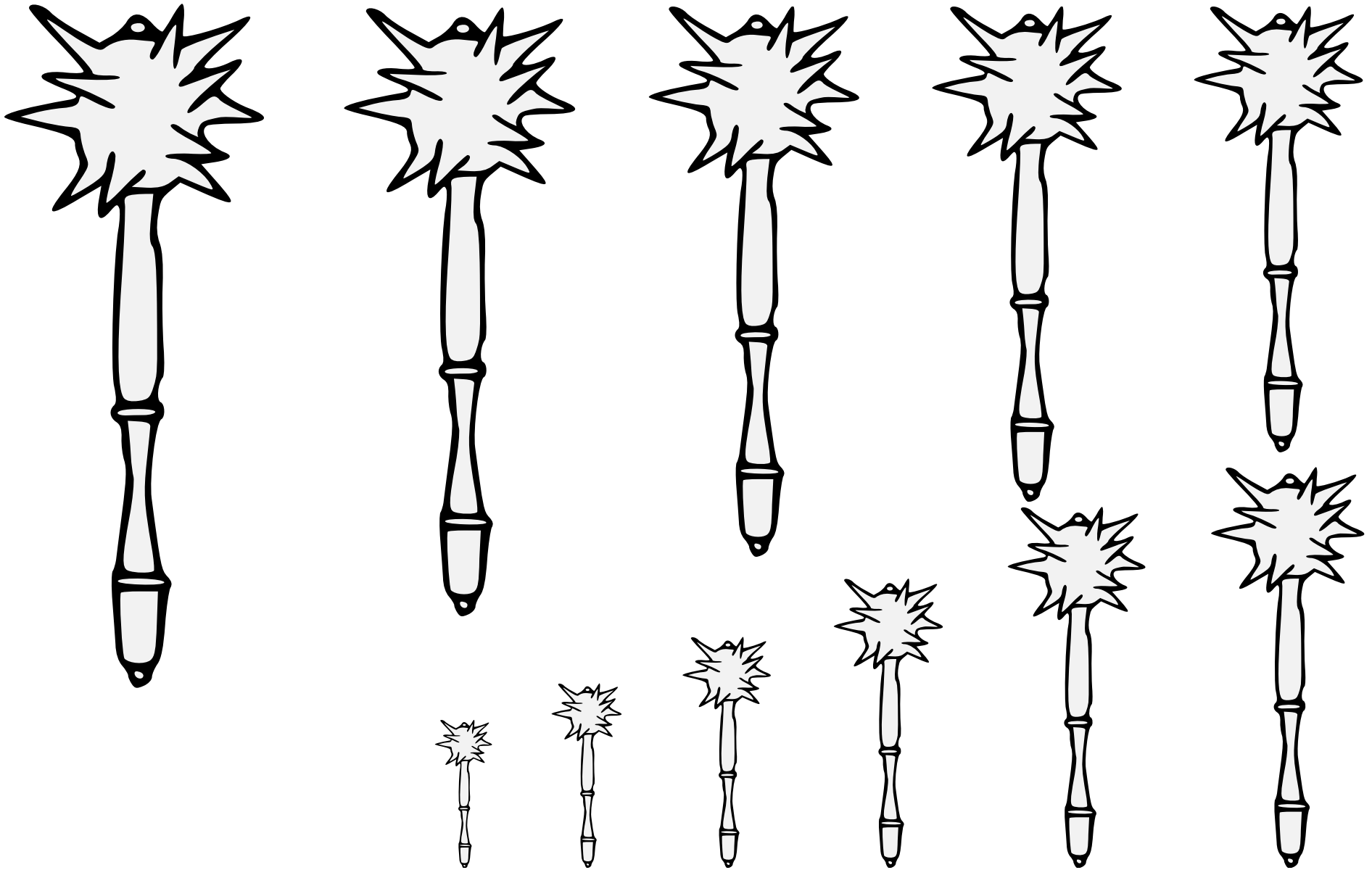

A fearsome weapon.

Default orientation: hilt to base. No proper coloration.

Source: Pennsic Traceable Art. Artist unknown.

Mace, Spiked (2) 21.175

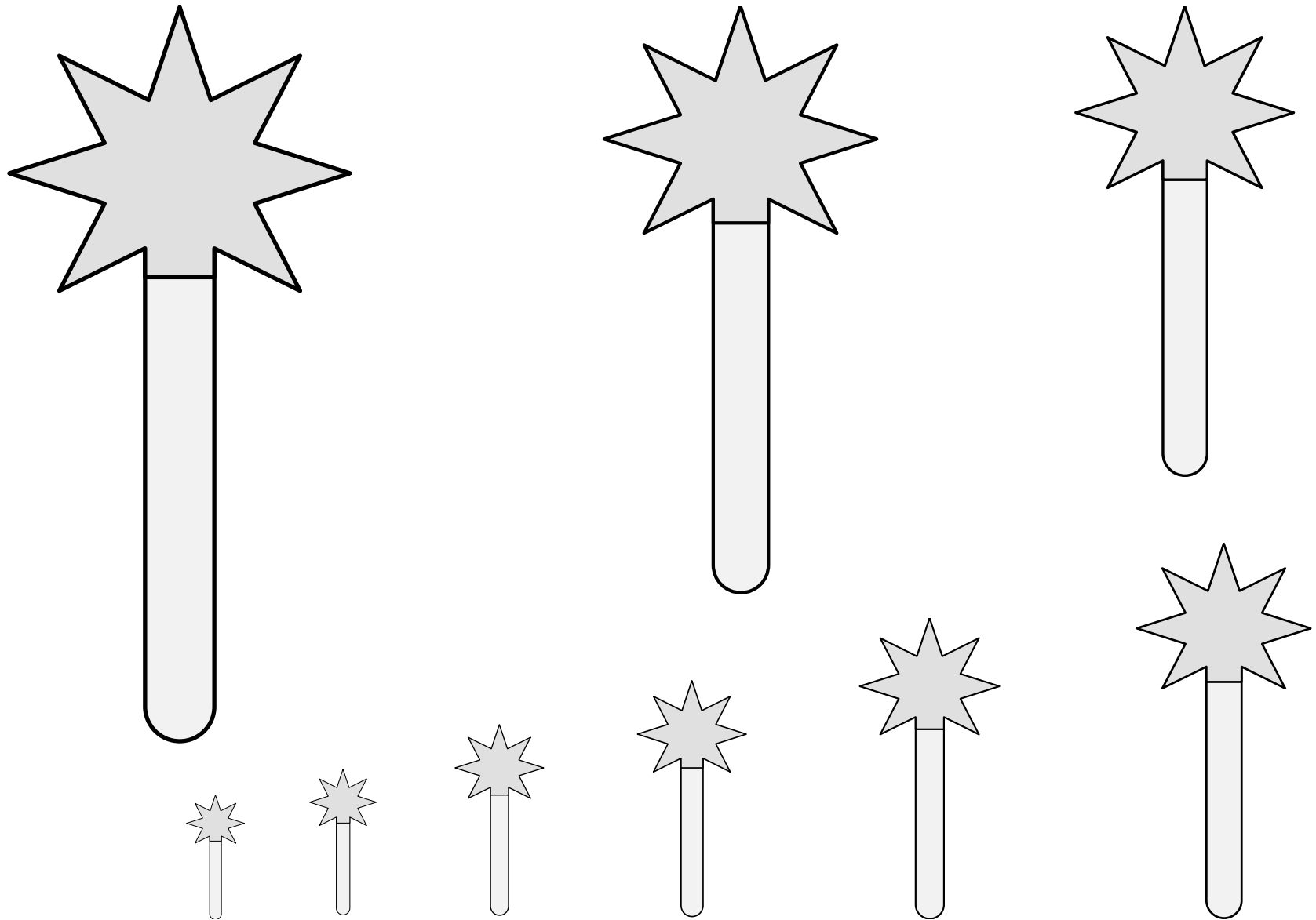

A fearsome weapon.

Default orientation: hilt to base. No proper coloration.

Source: Zurich Roll. Artist unknown. Adapted by Mathghamhain Ua Ruadháin.

**Mace, Spiked (3) 21.176**

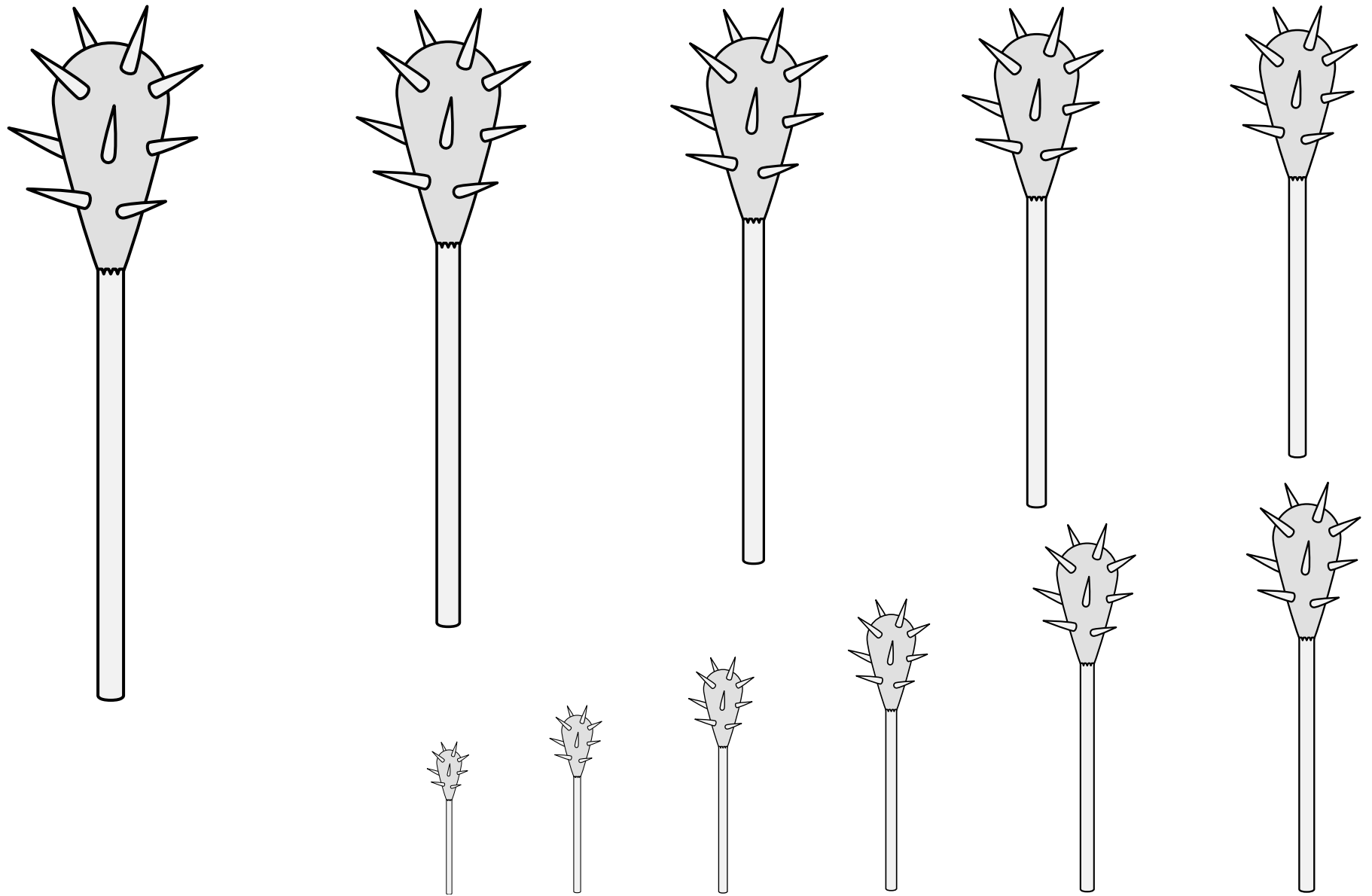

A fearsome weapon.

Default orientation: hilt to base. No proper coloration.

Source: Album Amicorum des Élèves de Morel. Artist unknown. (Folio 4.)

Mace, Spiked (4) 21.177

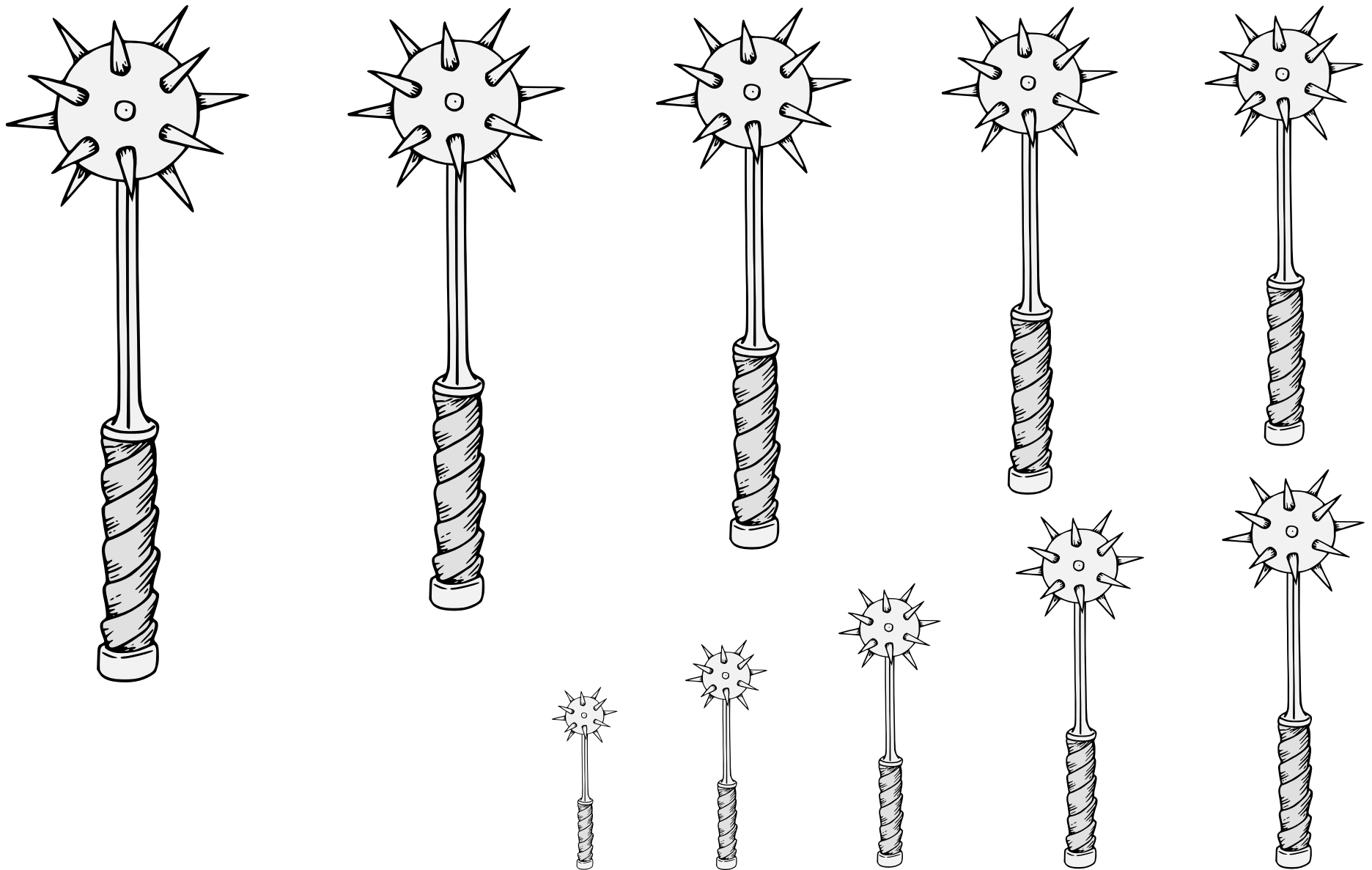

A fearsome weapon.

Default orientation: hilt to base. No proper coloration.

Source: Heraldic Templates. Artist: Torric inn Björn.  
Adapted by Mathghamhain Ua Ruadháin.

Mace, Spiked (5) 21.178

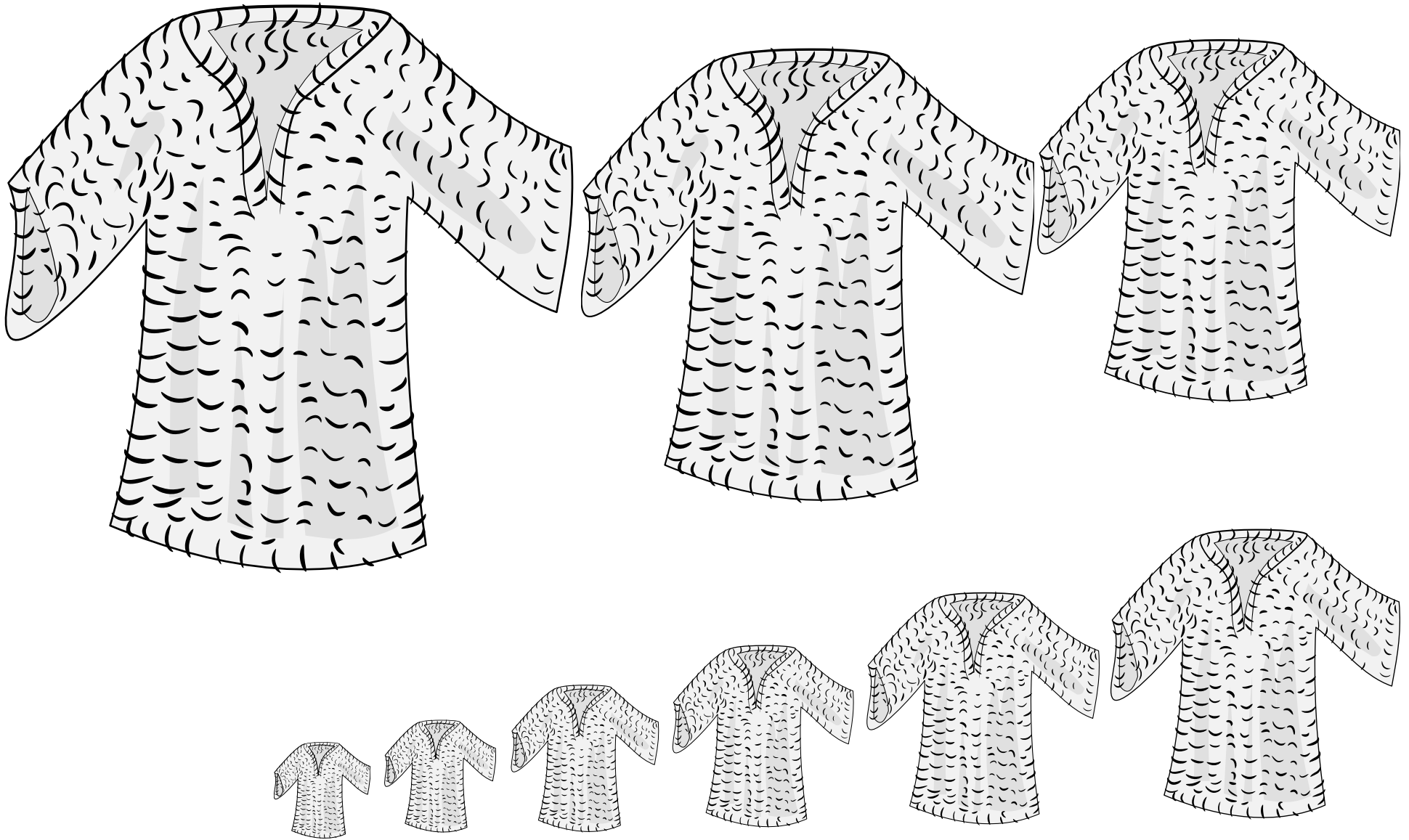

A protective piece of armor made of small metal rings.

Default orientation: upright and affronty. No proper coloration.

Artist: Jon Cheseby. Adapted from Stemmario Trivulziano (Italian, c. 1450).  
(From plate 235, arms of de Mayete.)

**Mail Shirt (1)** • 21.179



A protective piece of armor made of small metal rings.

Default orientation: upright and affronty. No proper coloration.

Source: Vocabulaire-Atlas Héraldique. Artist unknown. (Illustration 423.)

Mail Shirt (2) 21.180



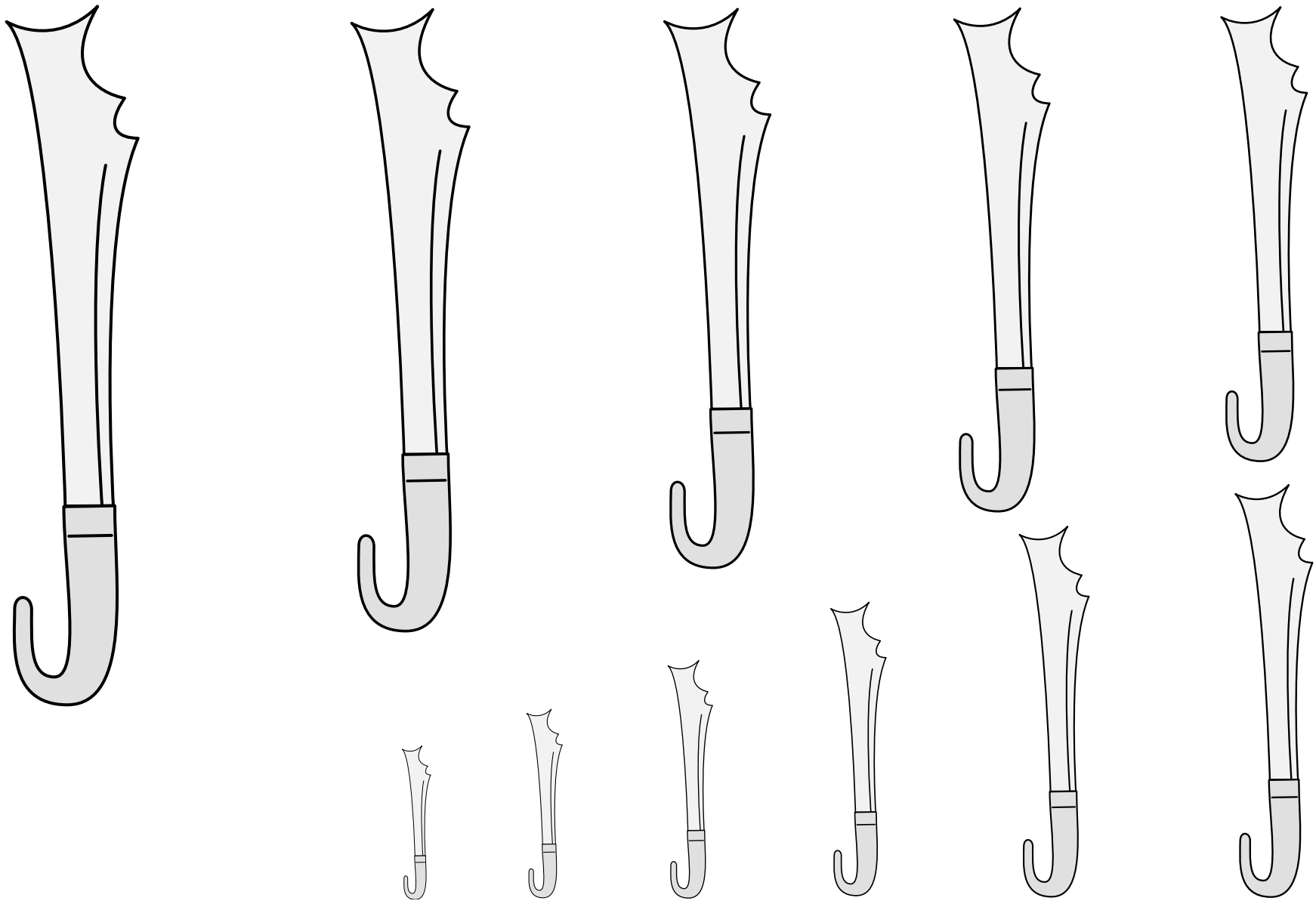

A sword with a hooked hilt and squared-off tip, constructed from an agricultural billhook.

Default orientation: point to chief. Proper coloration: blade argent, hilt Or.

Source: Maciejowski Bible. Artist unknown.

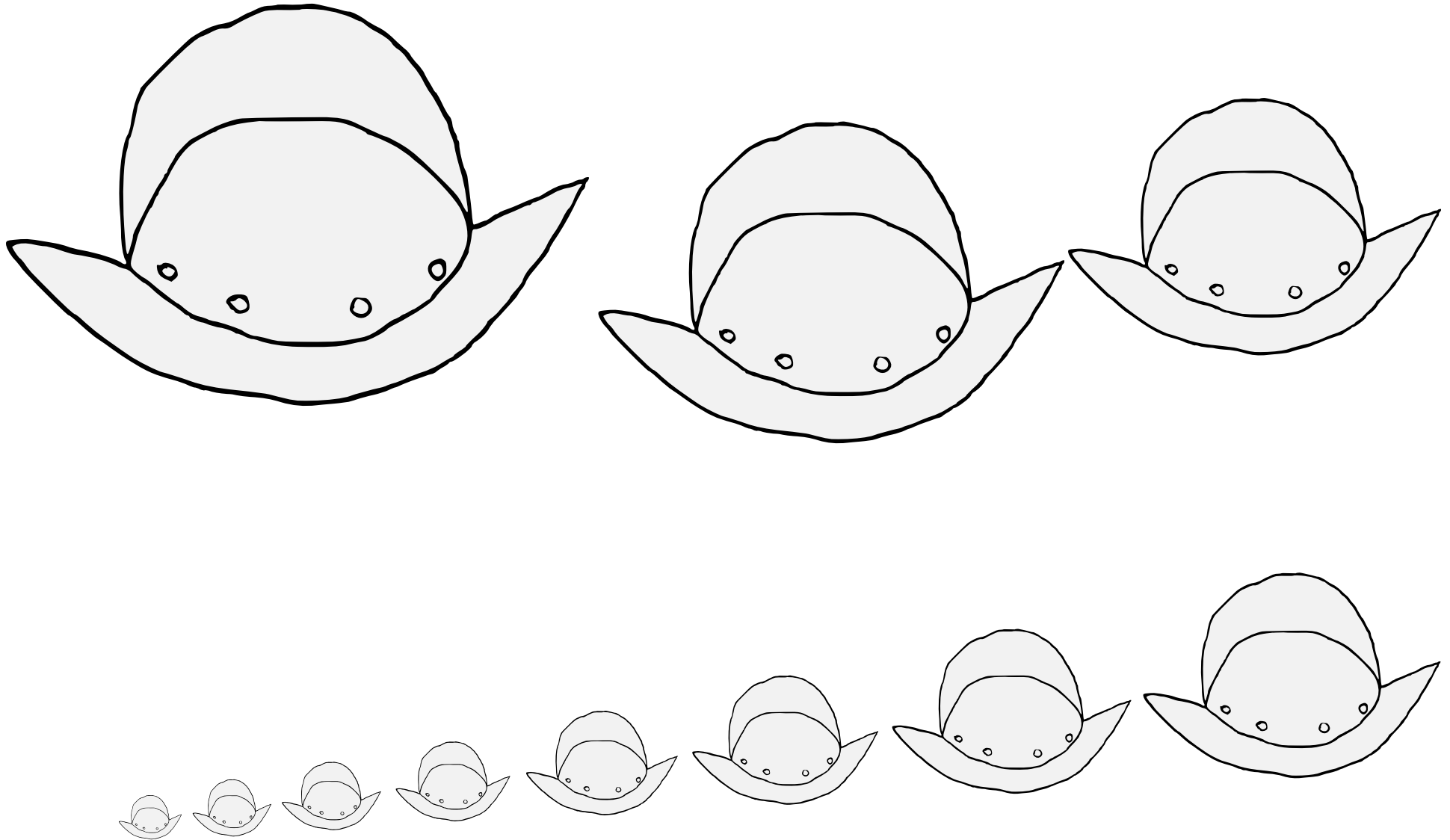

A type of armored helmet found in Spain.

Default orientation: crest to chief. No proper coloration.

Source: Pennsic Heralds' Point Artists. Artist: Unknown.

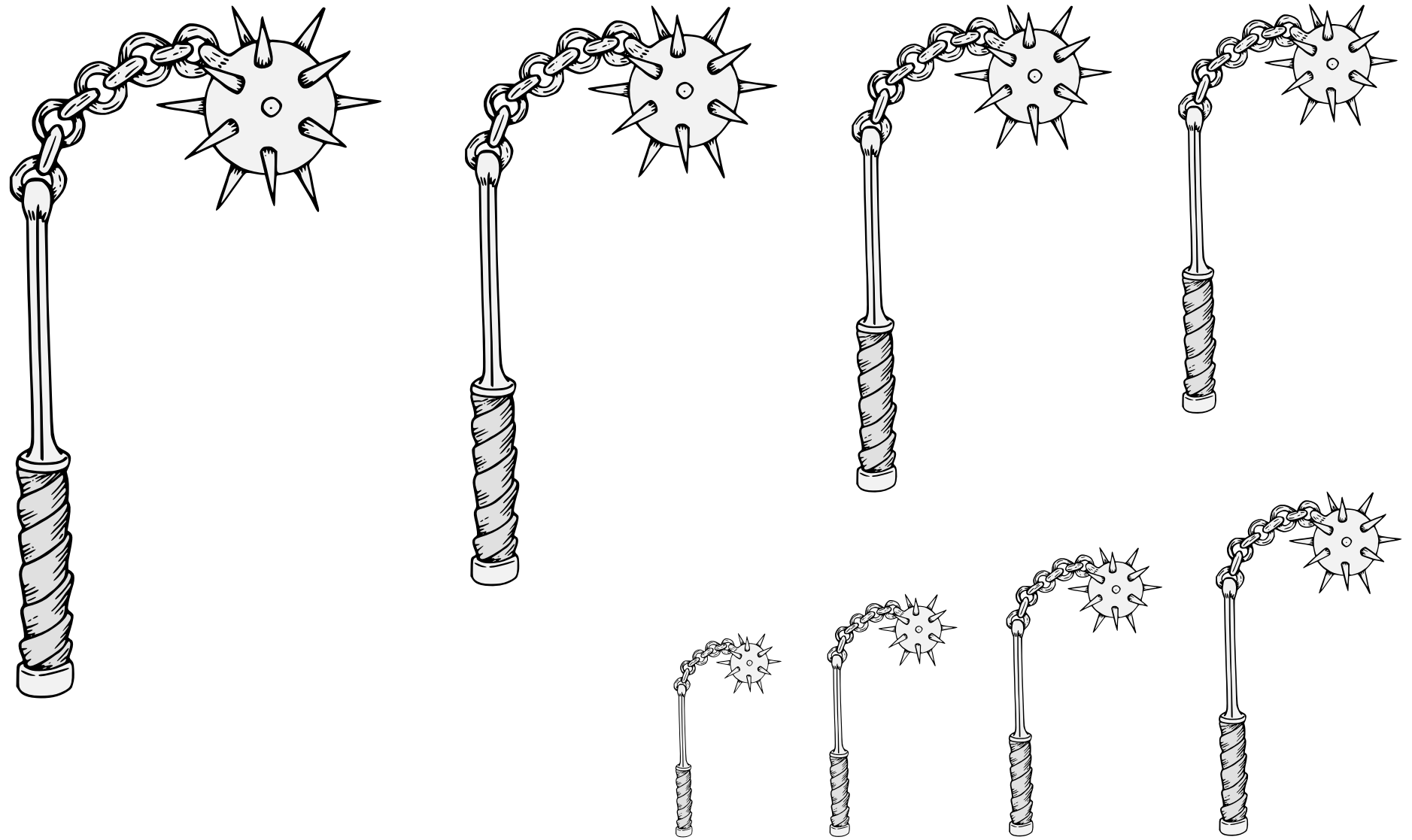

A fearsome weapon.

Default orientation: hilt to base. No proper coloration.

Source: Heraldic Templates. Artist: Torric inn Björn.

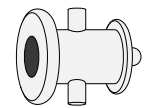
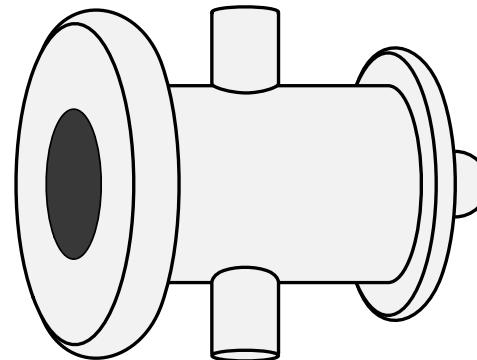
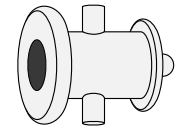
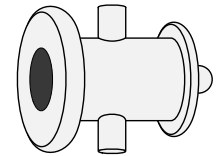
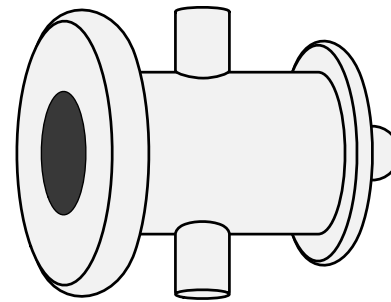
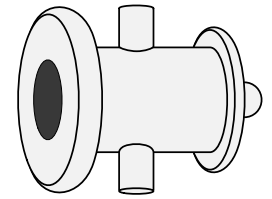
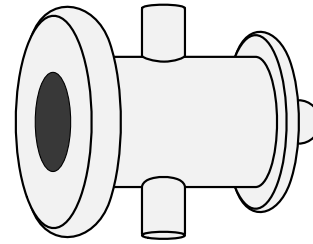
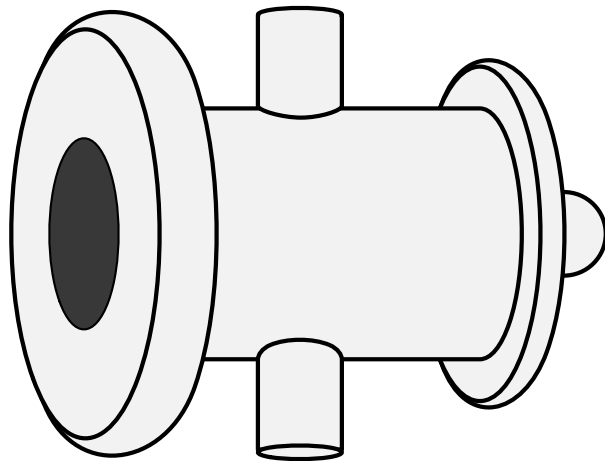
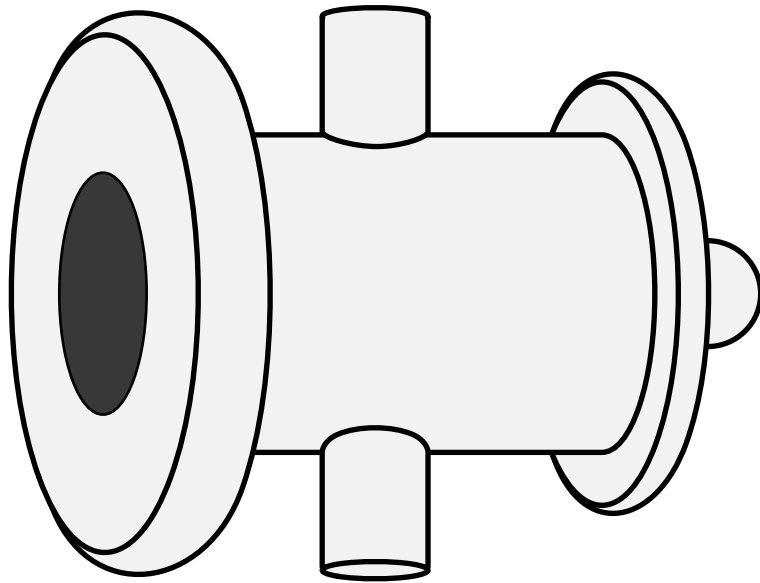

A short-barreled cannon.

Default orientation: aiming to dexter. No proper coloration.

Source: Siebmacher's Wappenbuch of 1605. Artist: Johann Siebmacher.  
(Arms of von Brösicke, folio 177.)

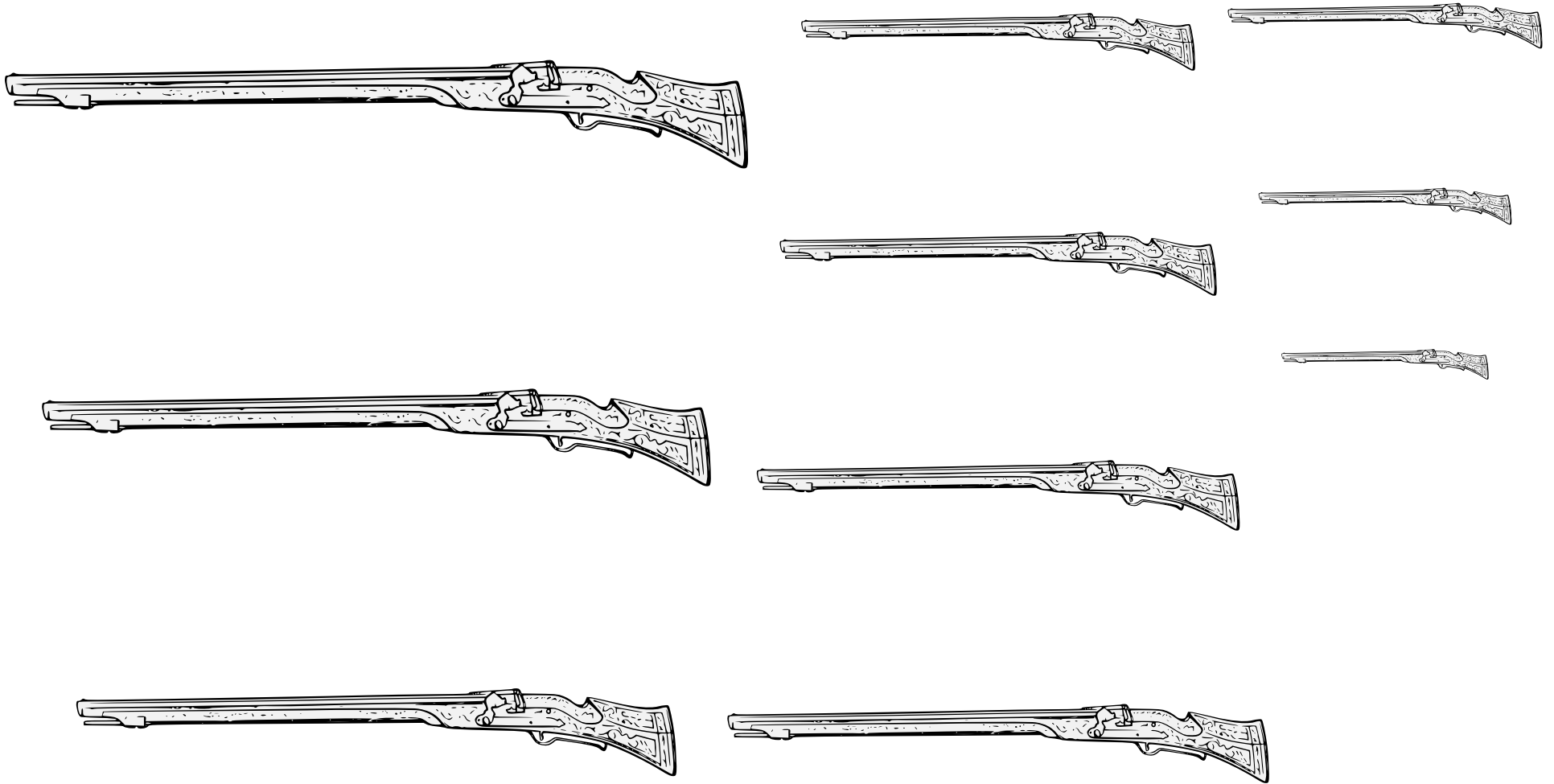

A long-barreled gun developed in the sixteenth century.

Default orientation: fesswise, shooting to dexter. Proper coloration: brown wood, black metal.

Source: A Cyclopedia of Costume. Artist unknown. (Volume I, page 339.)

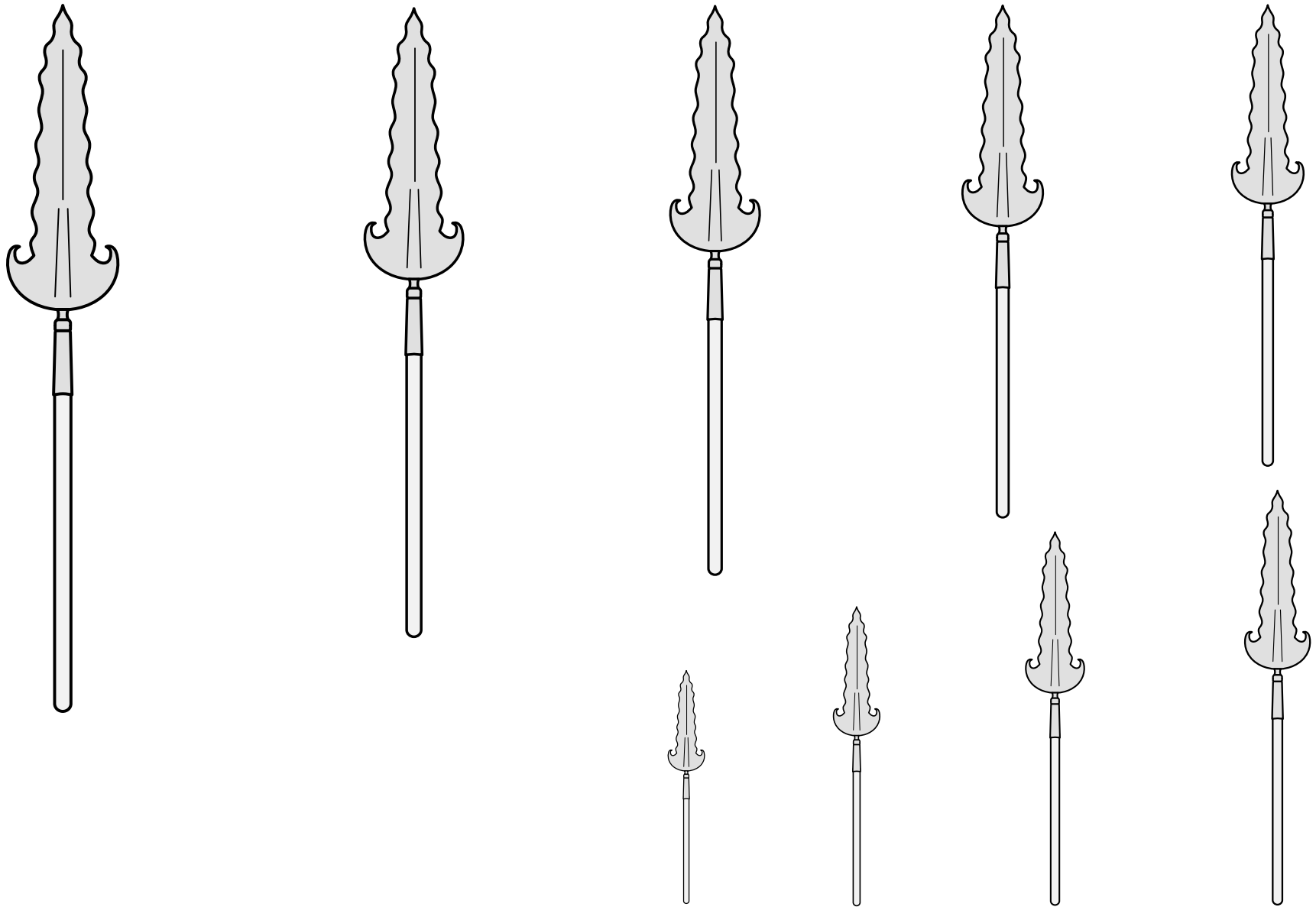

A specialized variety of spear with protrusions on each side of the blade.  
Default orientation: point to chief. No proper coloration.

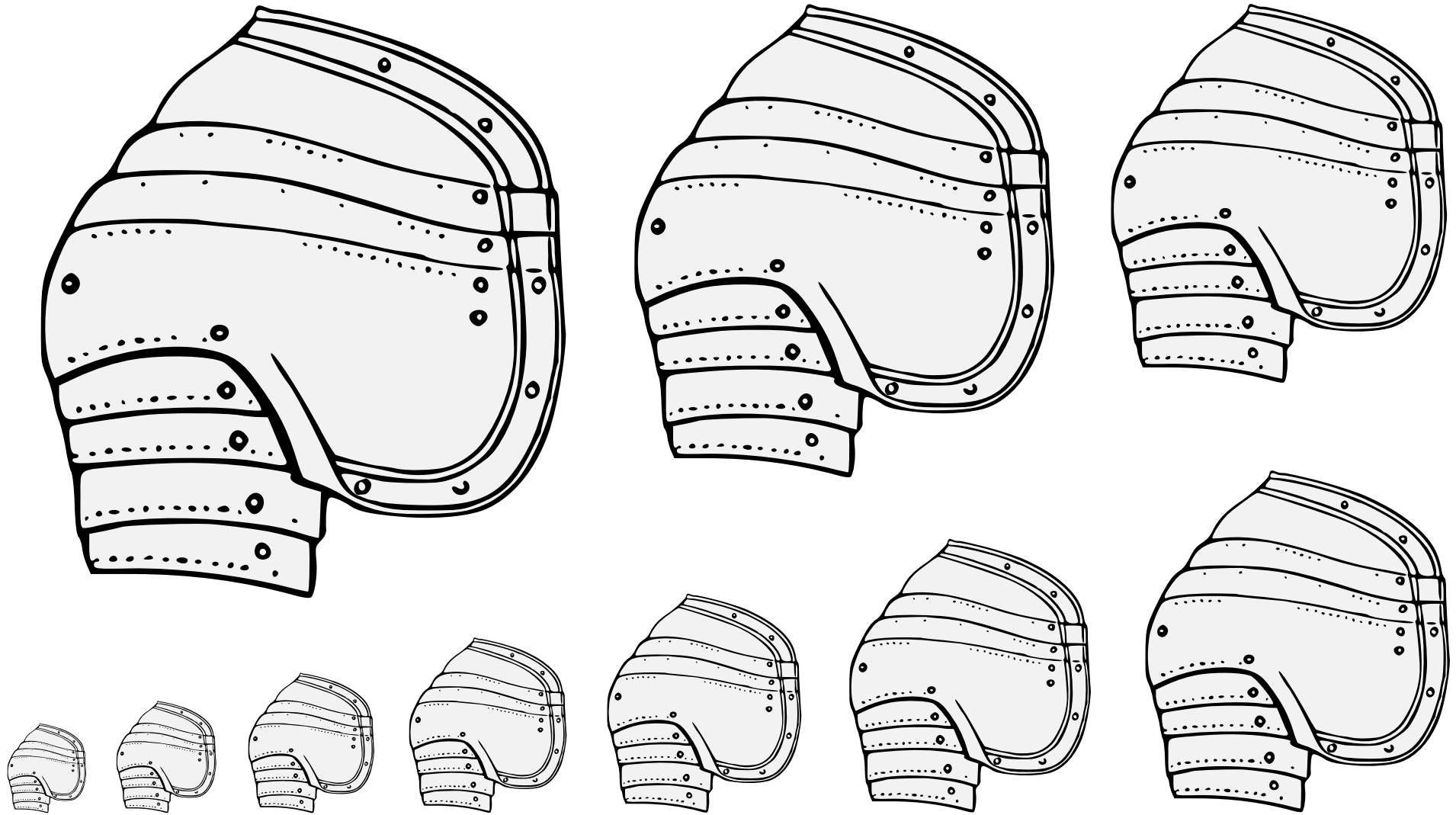

A piece of armor used to protect the shoulder.

Default orientation: dexter shoulder, upright. No proper coloration.

Source: A Cyclopedia of Costume. Artist unknown. (Volume I, page 390.)

**Pauldron (1)** 21.187

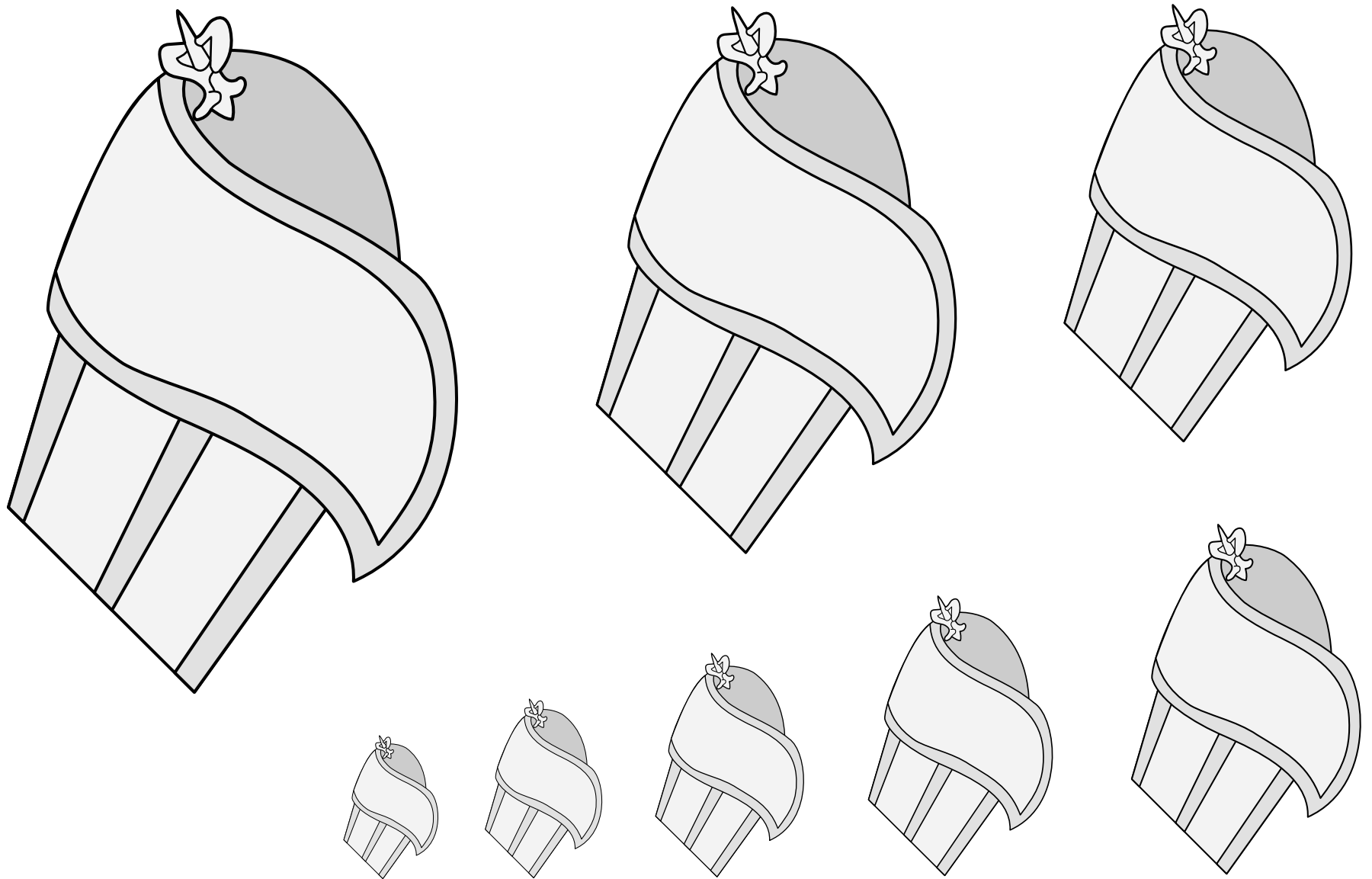

A piece of armor used to protect the shoulder.

Default orientation: dexter shoulder, upright. No proper coloration.

Source: A Display of Heraldry. Artist: John Guillim.  
(Manuscript folio 95r.) Adapted by Iago ab Adam.



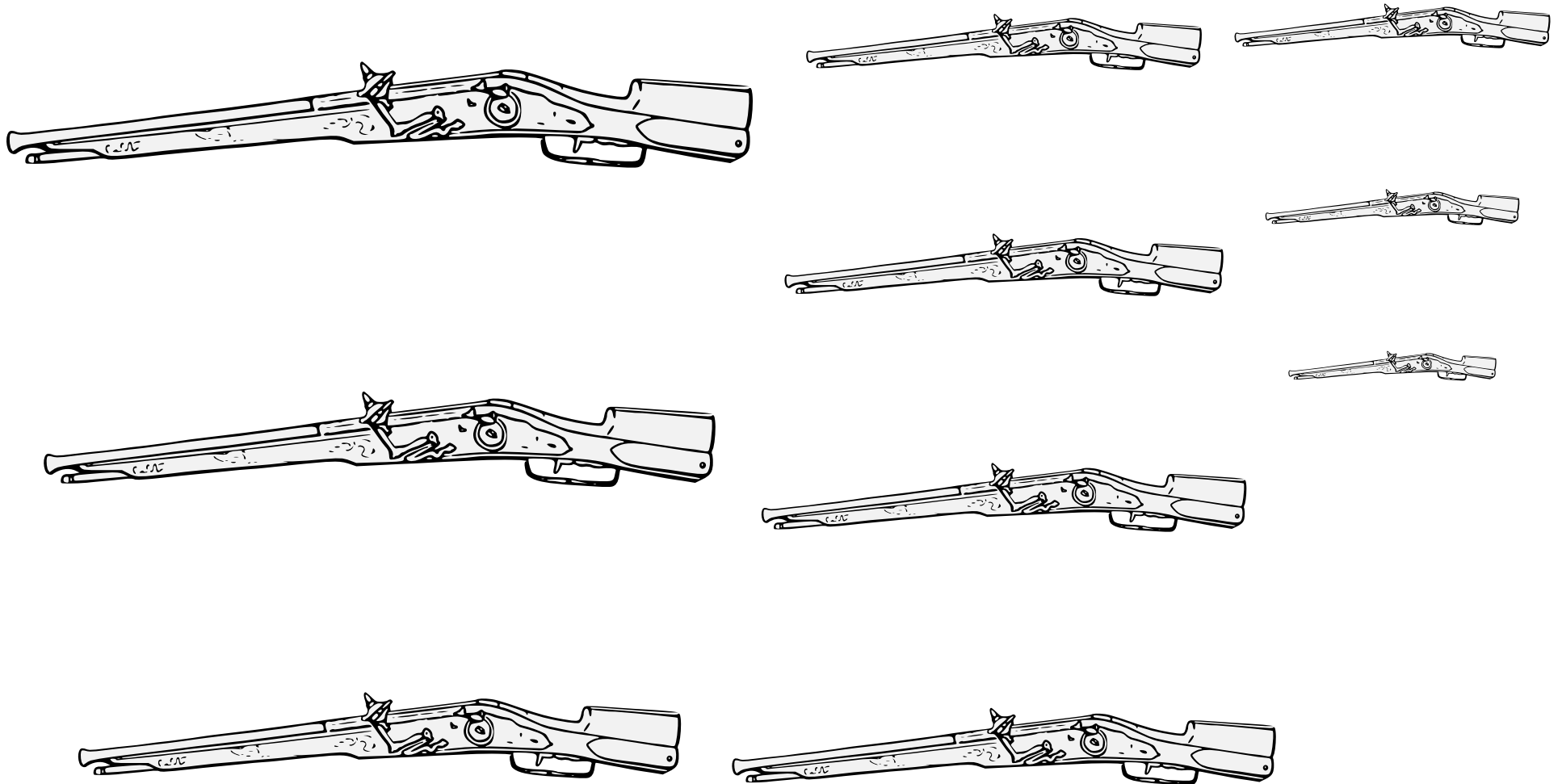

A mid-sized gun developed in the sixteenth century.

Default orientation: fesswise, shooting to dexter.

Proper coloration: brown wood, black metal.

Source: A Cyclopedia of Costume. Artist unknown. (Volume I, page 395.)

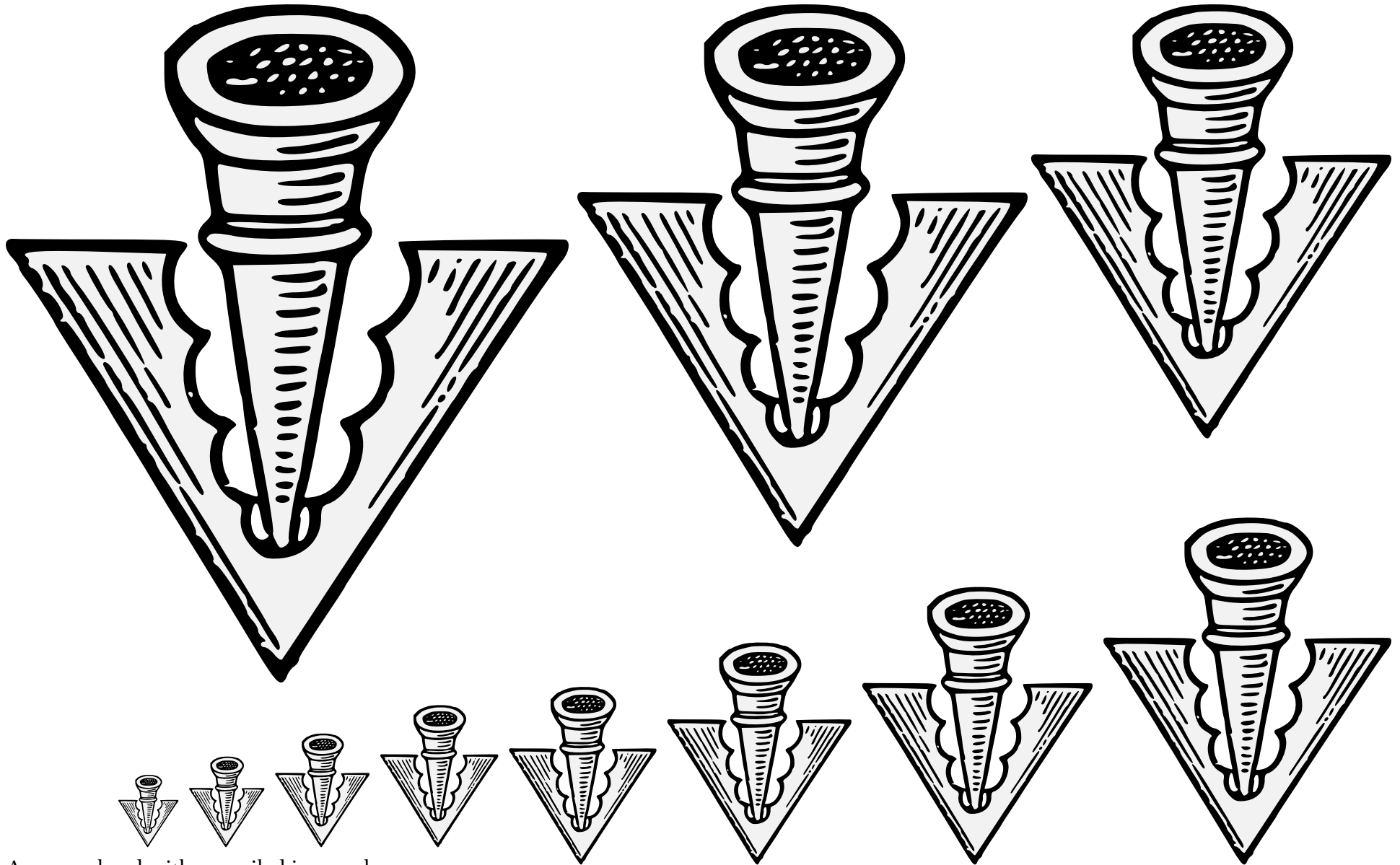

An arrowhead with engrailed inner edges.

See also Broad-arrow.

Default orientation: point to base. No proper coloration.

Source: A Complete Guide to Heraldry. Artist: Graham Johnston.

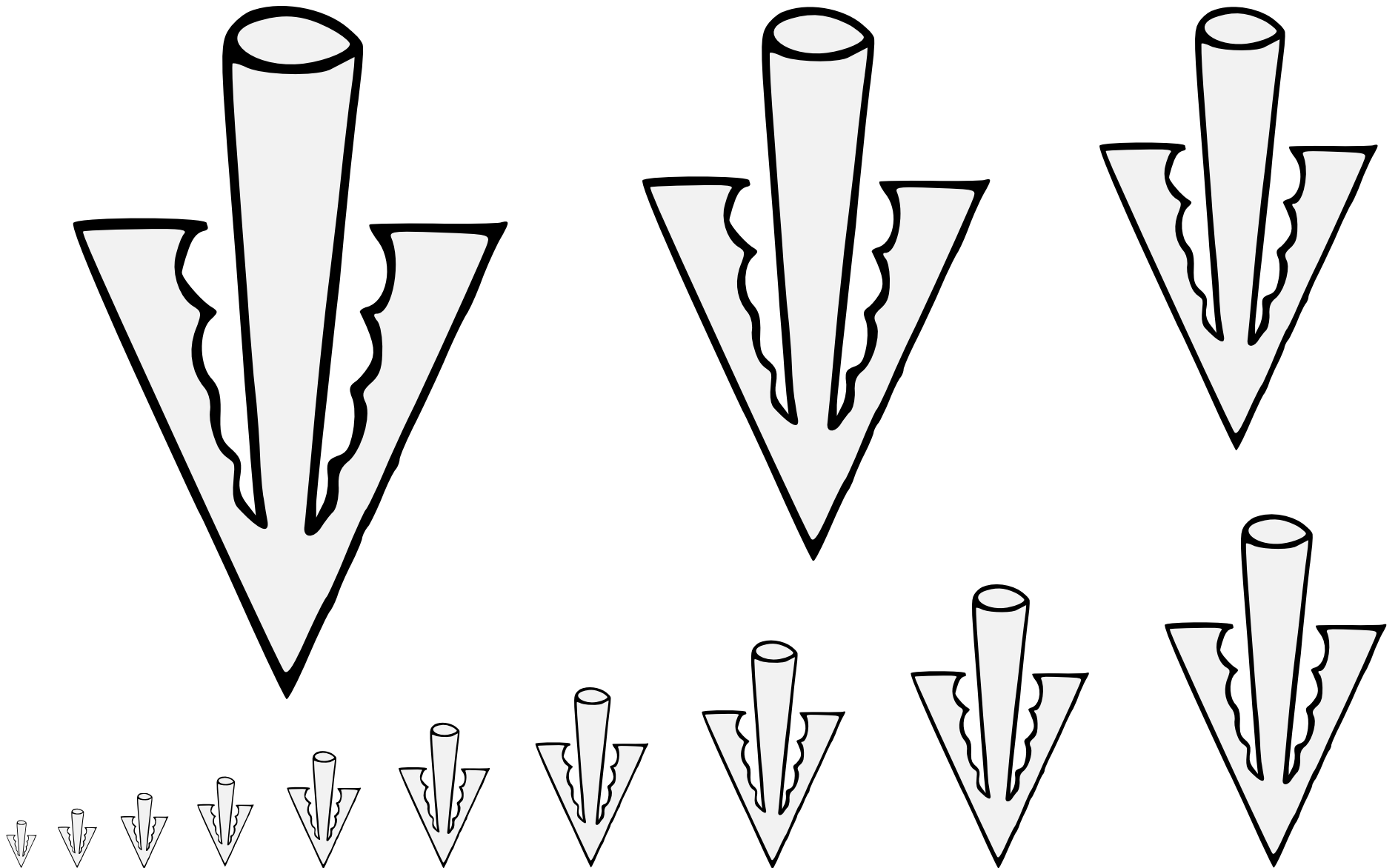

An arrowhead with engrailed inner edges.

See also Broad-arrow.

Default orientation: point to base. No proper coloration.

Source: Pennsic Traceable Art. Artist: Myfanwy ferch Rhiannon.

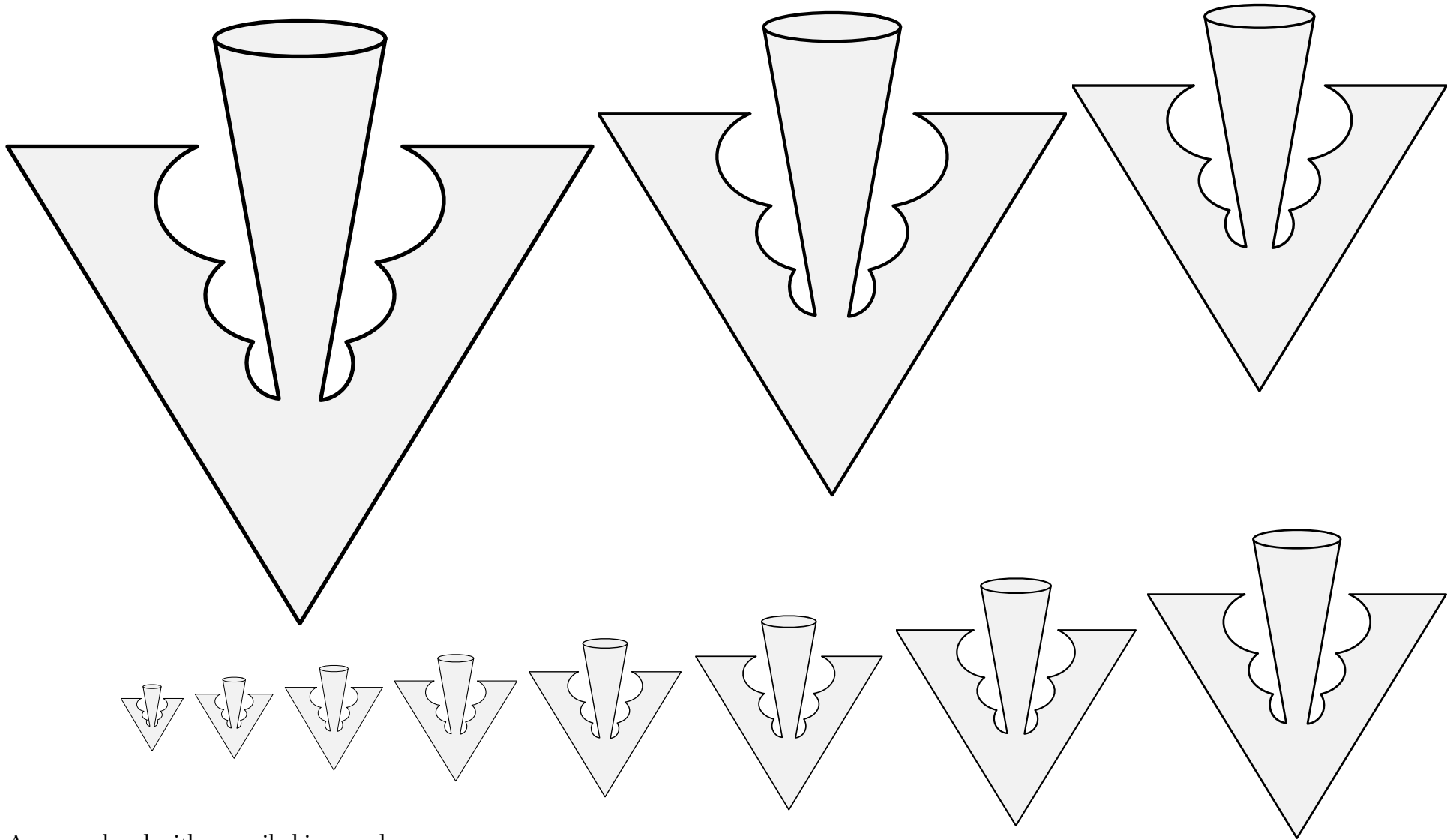

An arrowhead with engrailed inner edges.

See also Broad-arrow.

Default orientation: point to base. No proper coloration.

Source: Pennsic Traceable Art. Artist: Roana d'Evreux (attributed).  
Adapted by Mathghamhain Ua Ruadháin.

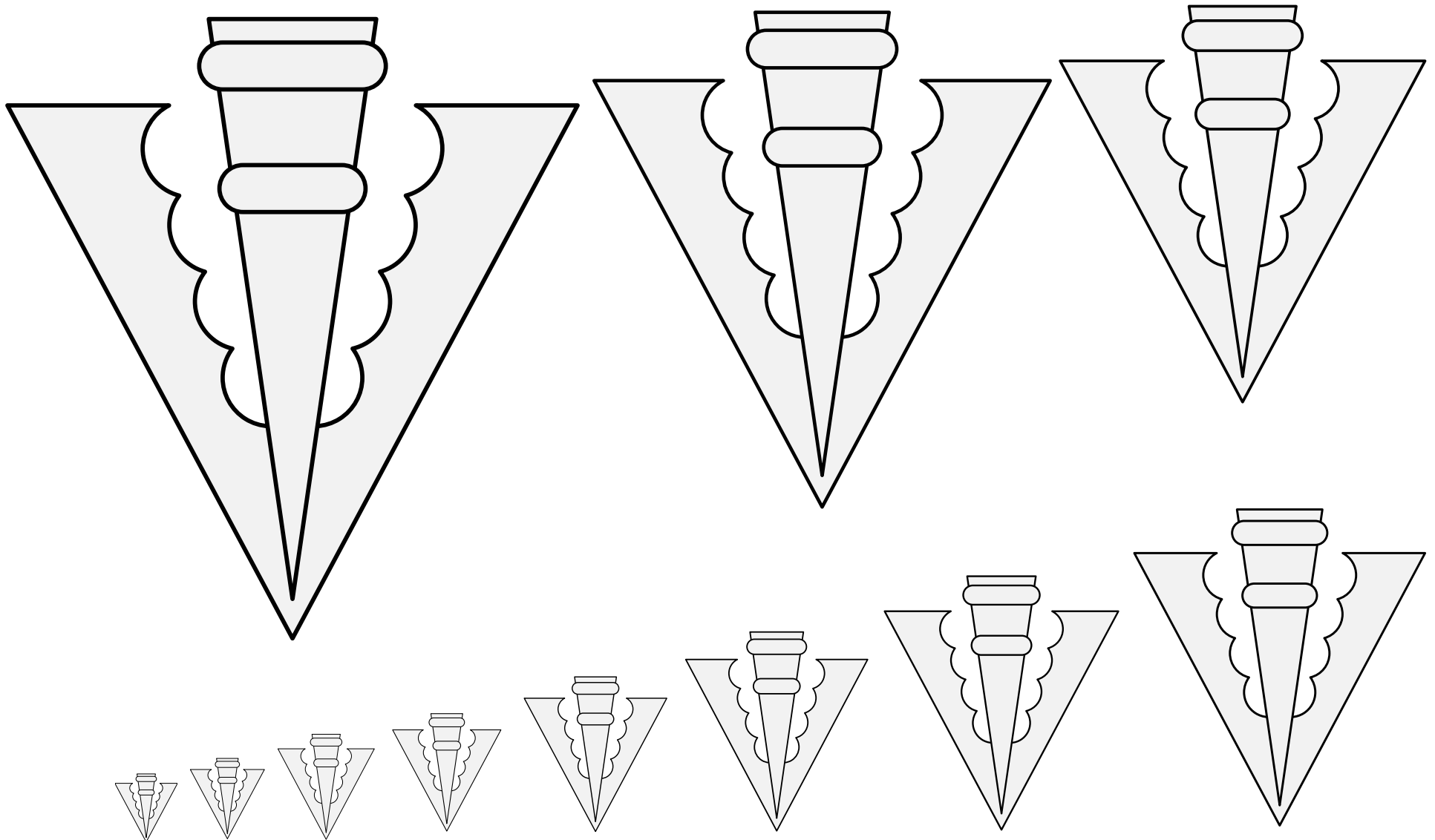

An arrowhead with engrailed inner edges.

See also Broad-arrow.

Default orientation: point to base. No proper coloration.

Source: Viking Answer Lady SVG Images For Heralds. Artist: Gunnvôr silfráhr.

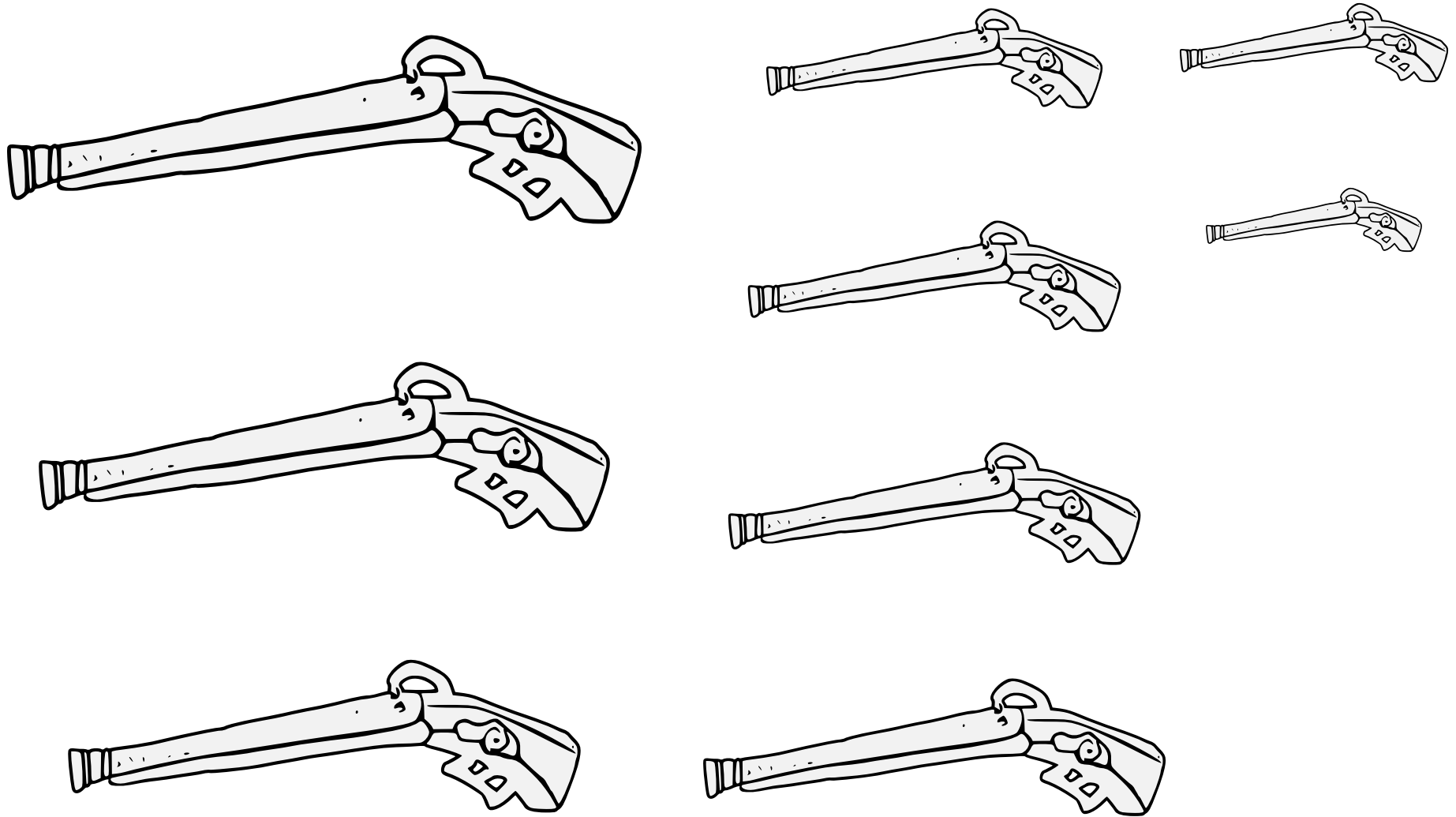

A small gun developed in the sixteenth century.

Default orientation: fesswise, shooting to dexter.

Proper coloration: brown wood, black metal.

Source: Queens College MS 72. Artist unknown. (Folio 113v.)

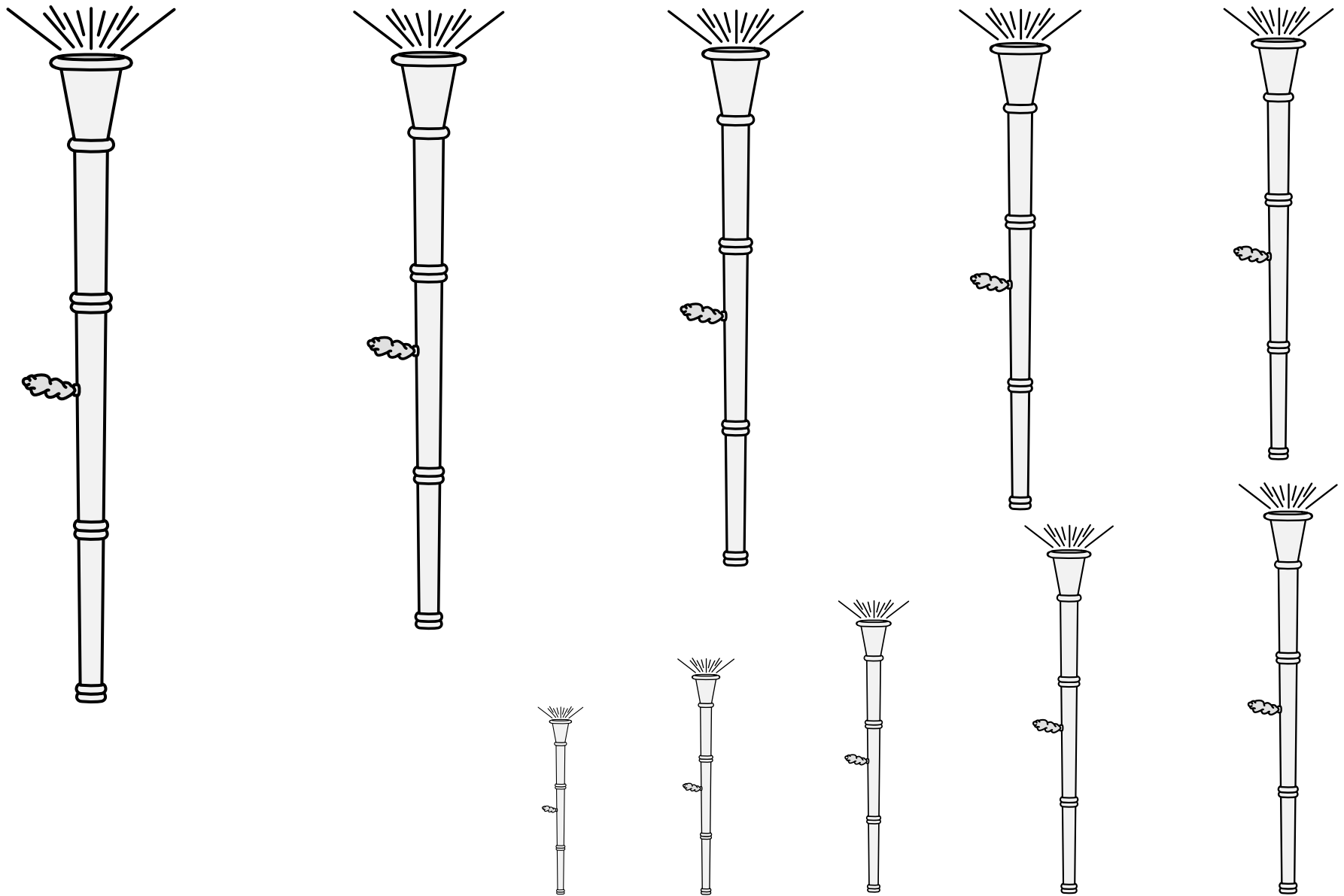

An early type of portable firearm mounted on a very long stock.  
Default orientation: palewise, firing to chief. Proper coloration unknown.  
Source: A Cyclopaedia of Costume. Artist unknown. (Volume I, page 233.)

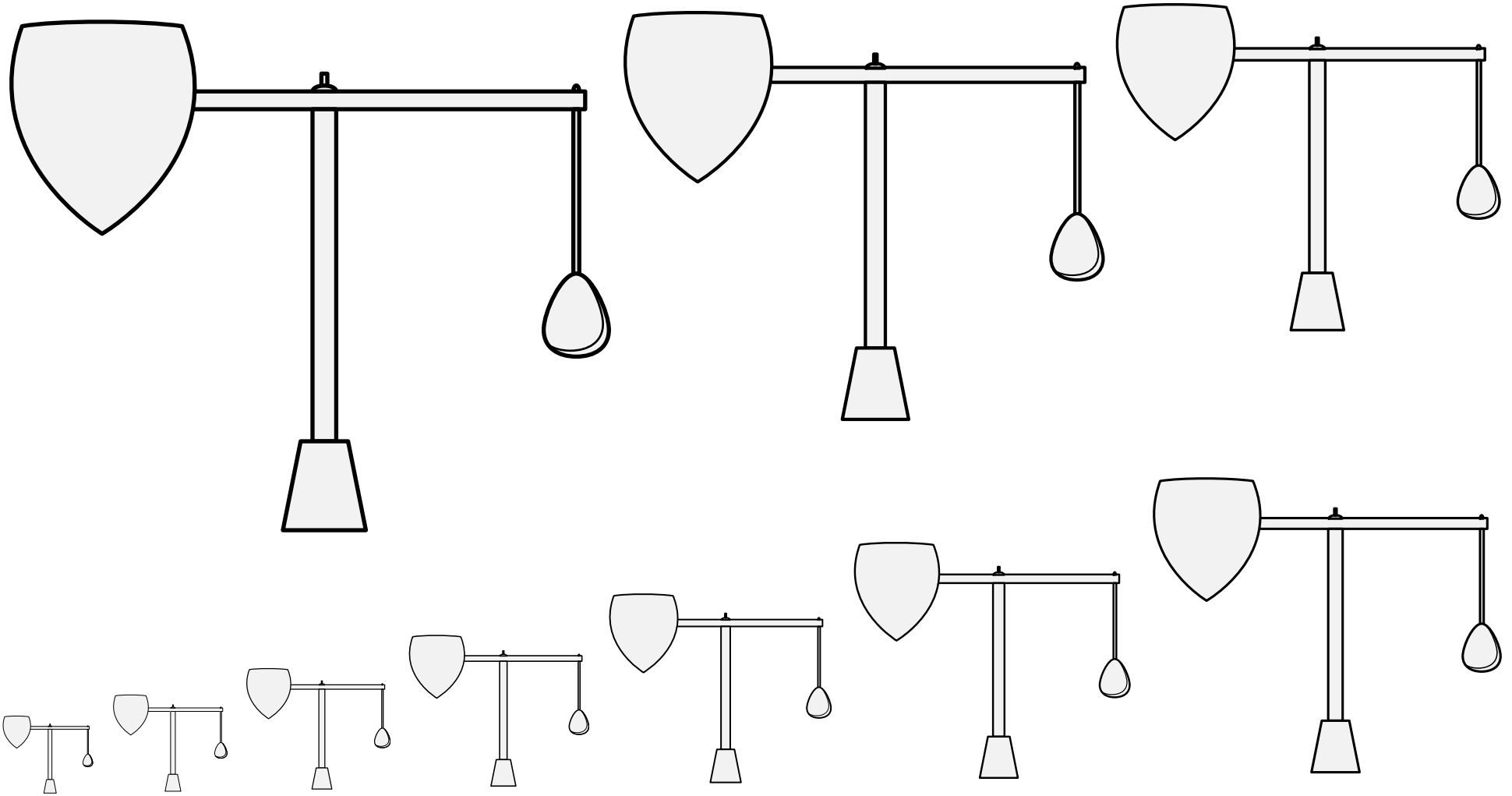

A pivoting target used for jousting practice.



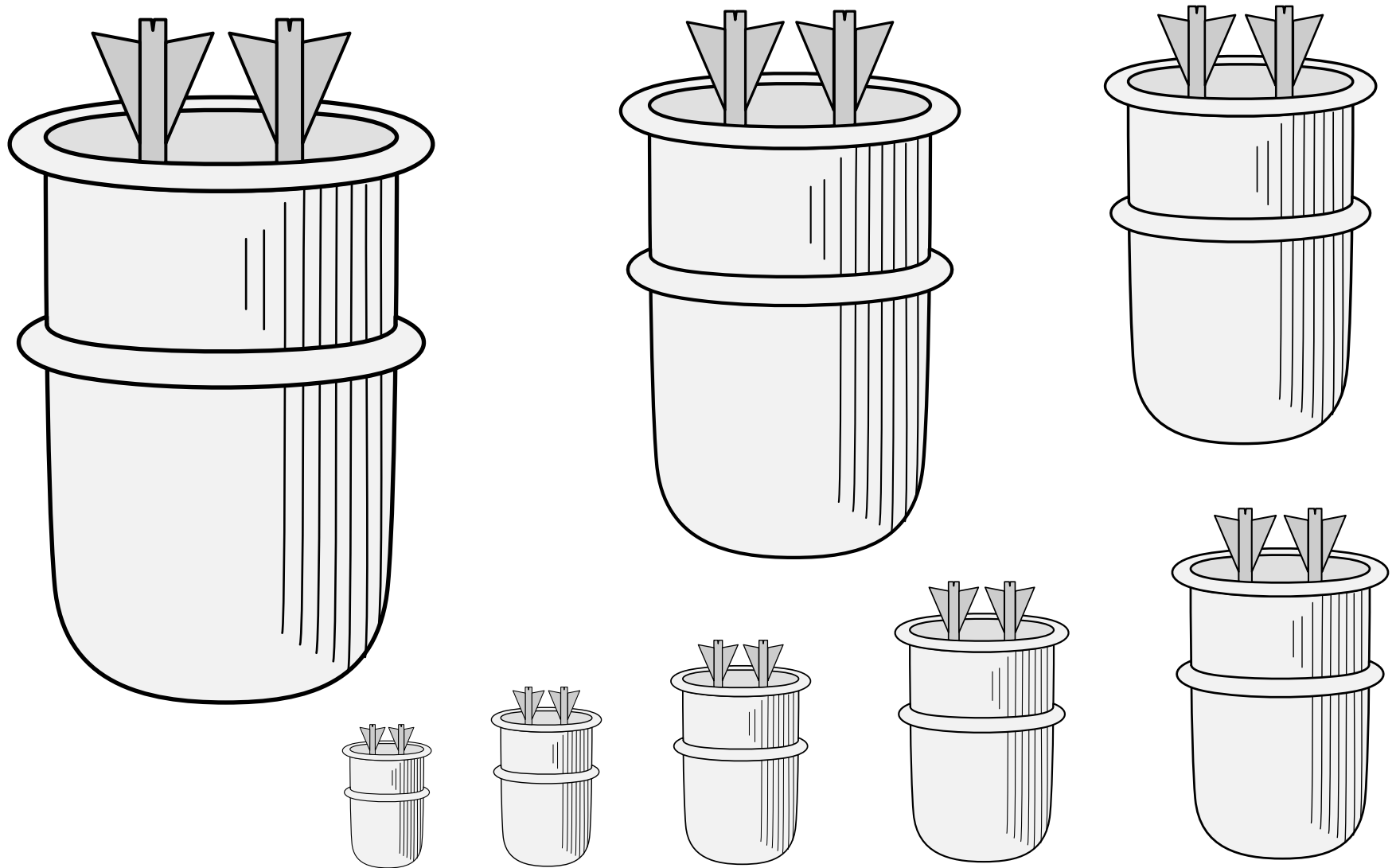

A protective carrying case for arrows.

Commonly shown with fletched arrows protruding from it.

Default orientation: upright. No proper coloration.

Source: Guillim's Display of Heraldry. Artist unknown.

(Page 247, arms of Lloyd of Holyrood.)

Adapted by Mathghamhain Ua Ruadháin.

**Quiver with Two Arrows • 21.197**

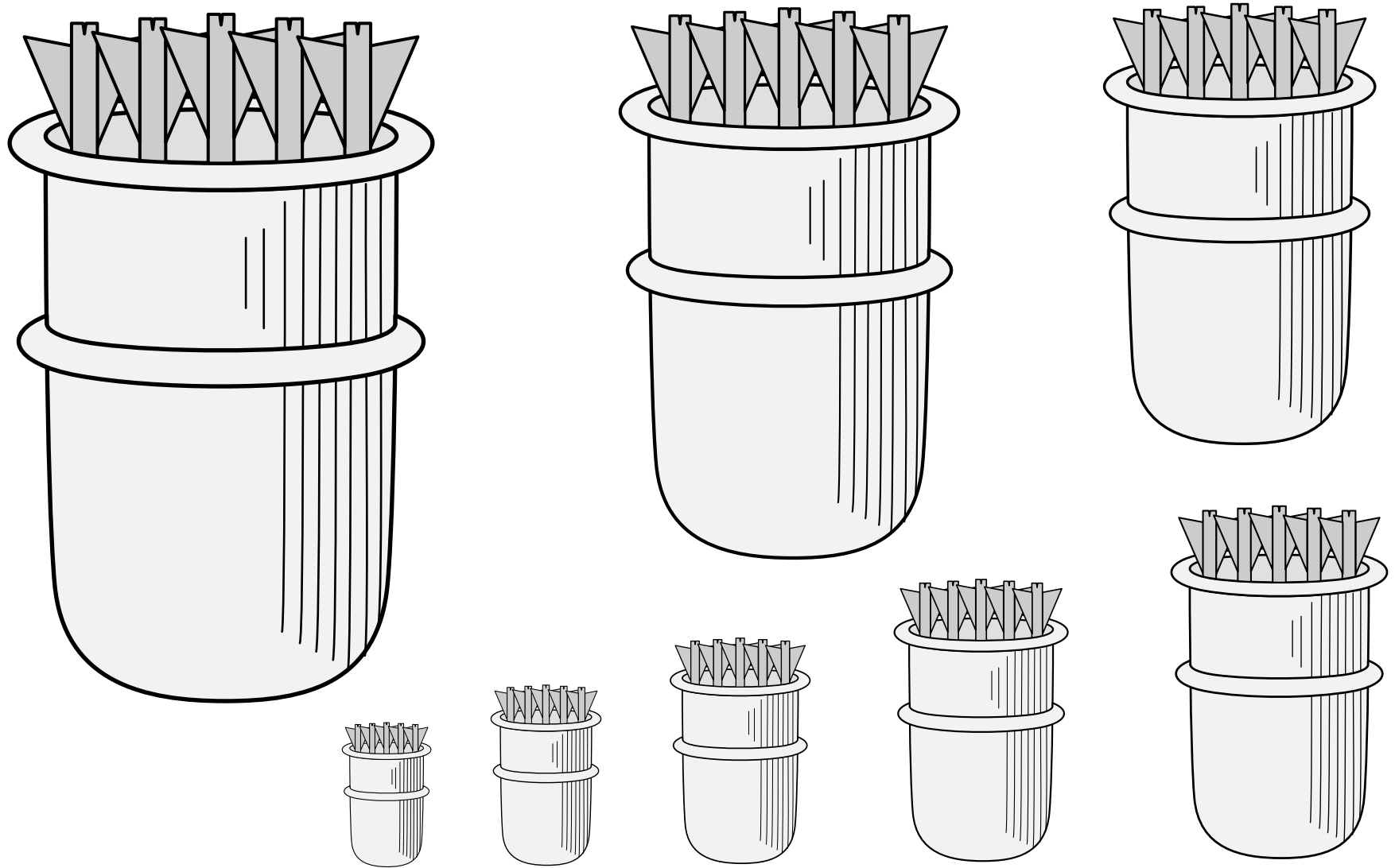

A protective carrying case for arrows.

Commonly shown with fletched arrows protruding from it.

Default orientation: upright. No proper coloration.

Source: Guillim's Display of Heraldry. Artist unknown.  
(Page 247, arms of Lloyd of Holyrood.)

**Quiver with Five Arrows** 21.198

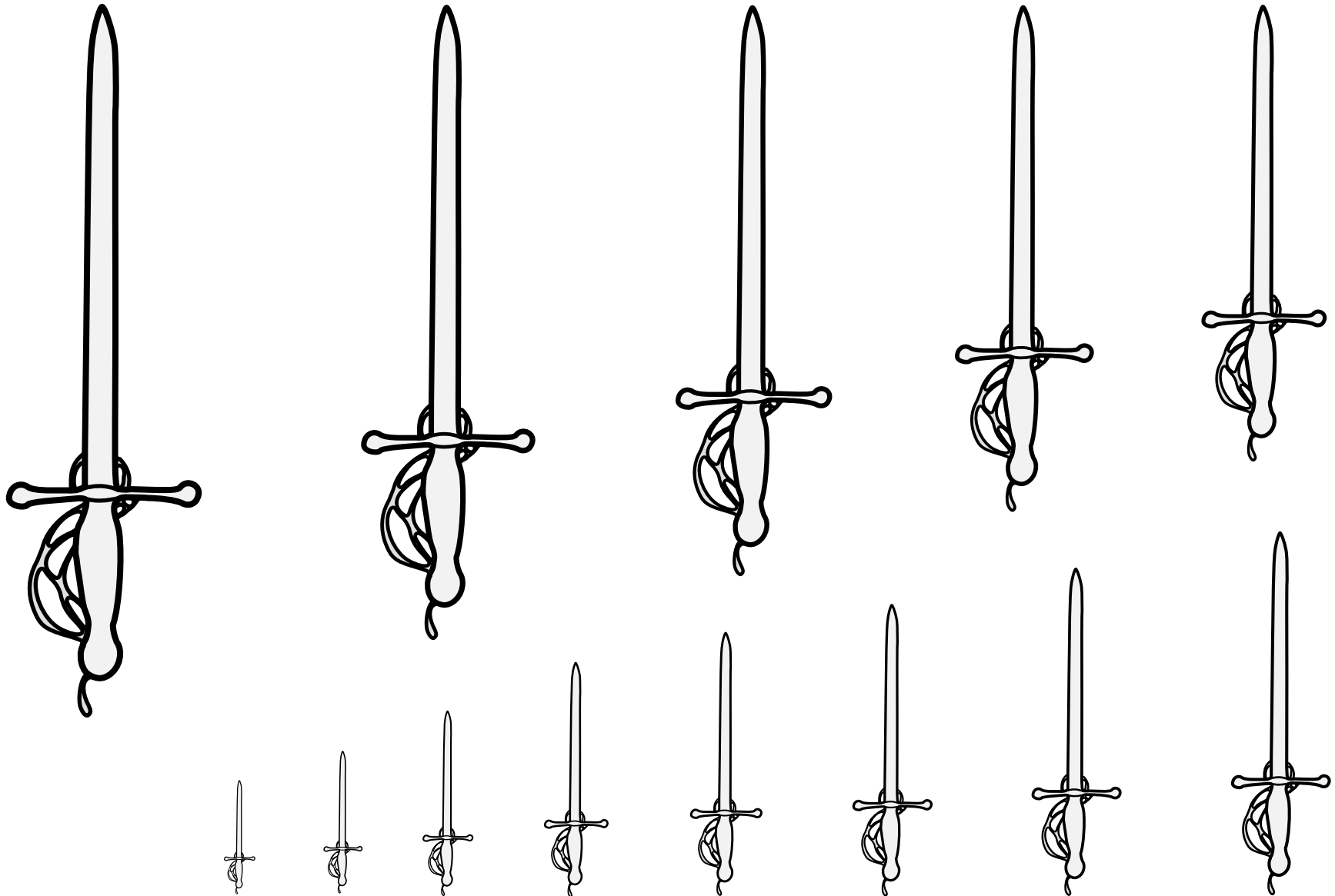

A light sword with a basket hilt and quillons.

Default orientation: palewise, point to chief.

Source: Pennsic Traceable Art. Artist unknown.  
Adapted by Mathghamhain Ua Ruadháin.

Rapier (1) 21.199

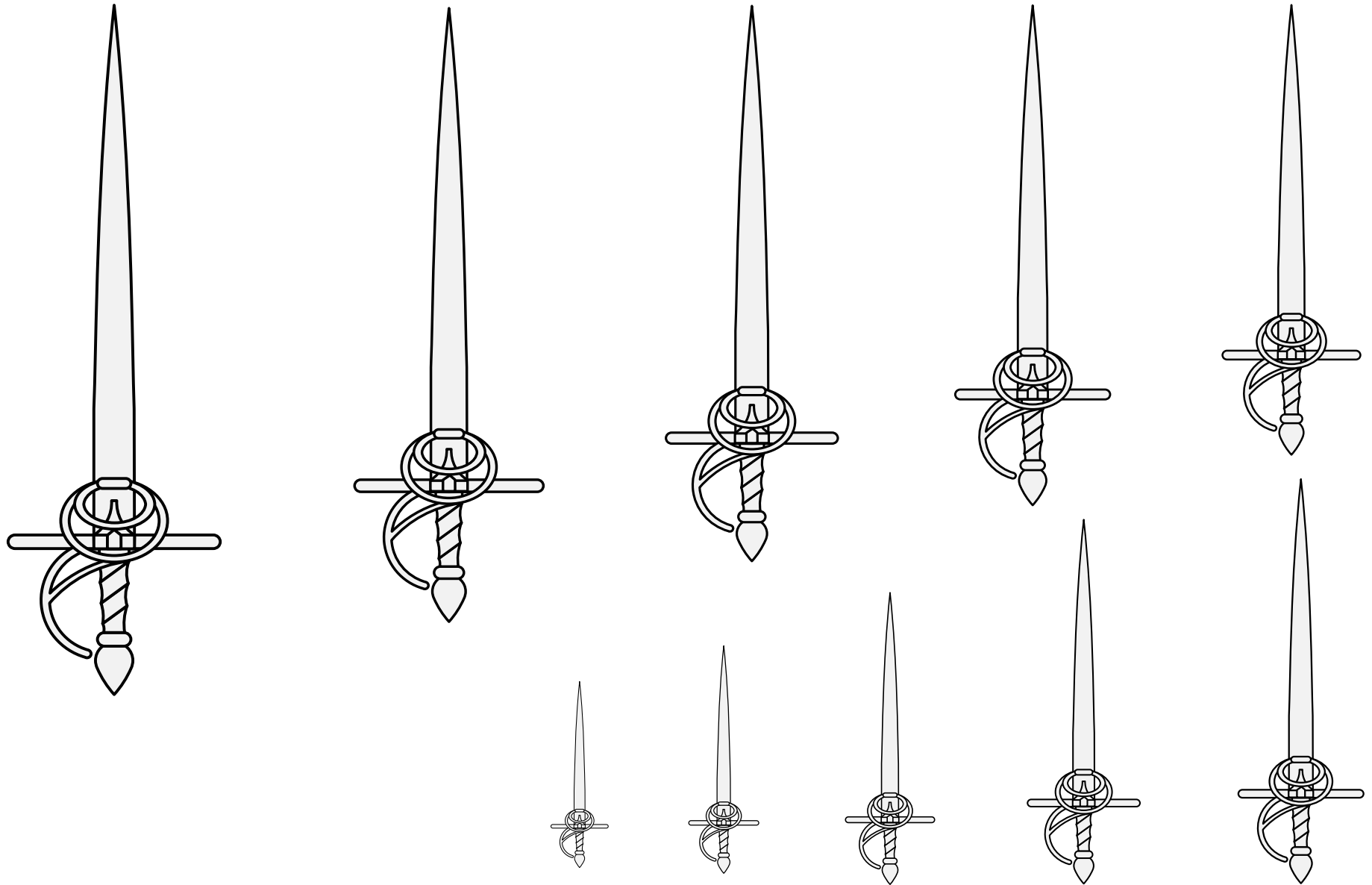

A light sword with a basket hilt and quillons.

Default orientation: palewise, point to chief.

Source: SVG Heraldry Components. Artist: Nicholas de Estleche.  
Adapted from an illustration by Gunnvôr silfrahárr.

Rapier (2) 21.200

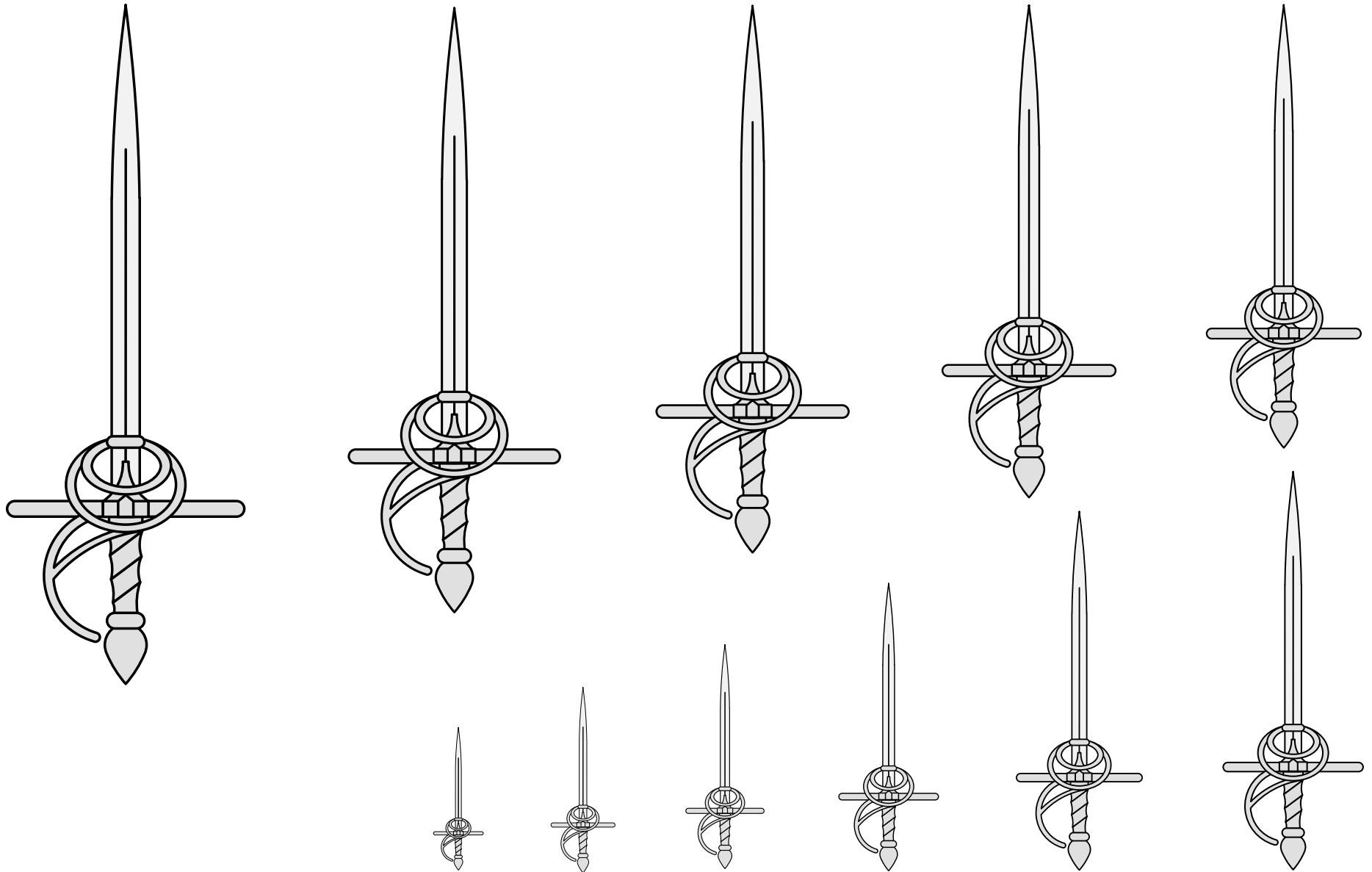

A light sword with a basket hilt and quillons.

Default orientation: palewise, point to chief. Proper coloration: blade argent, hilt Or.

Source: Viking Answer Lady SVG Images For Heraldists. Artist: Gunnvôr silfráhr.

Rapier (3) 21.201

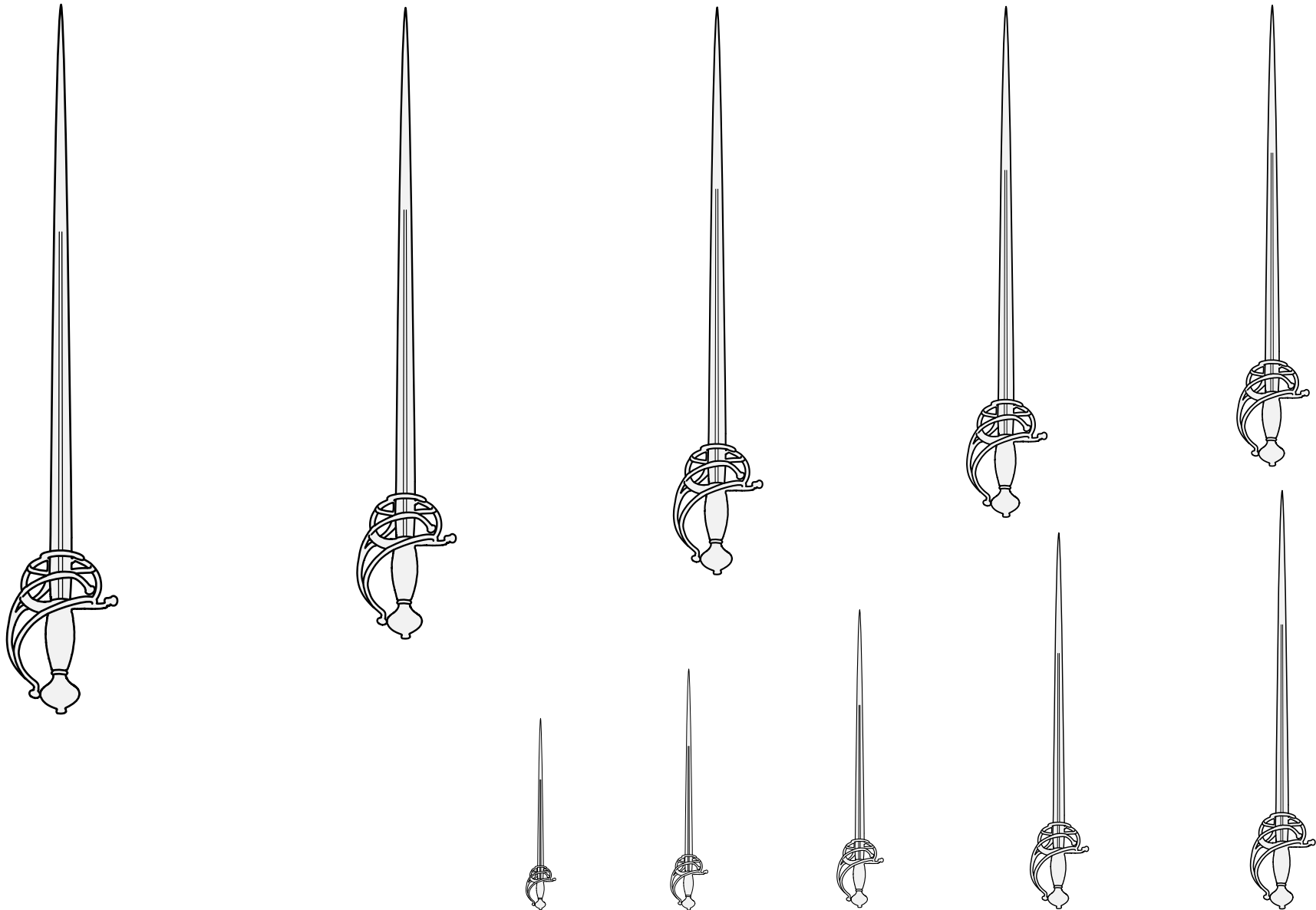

A light sword with a basket hilt and quillons.

Default orientation: palewise, point to chief. Proper coloration: blade argent, hilt Or.

Adapted from images of a sixteenth-century Italian rapier.  
(Metropolitan Museum of Art item 2010.200.)

Rapier (4) 21.202

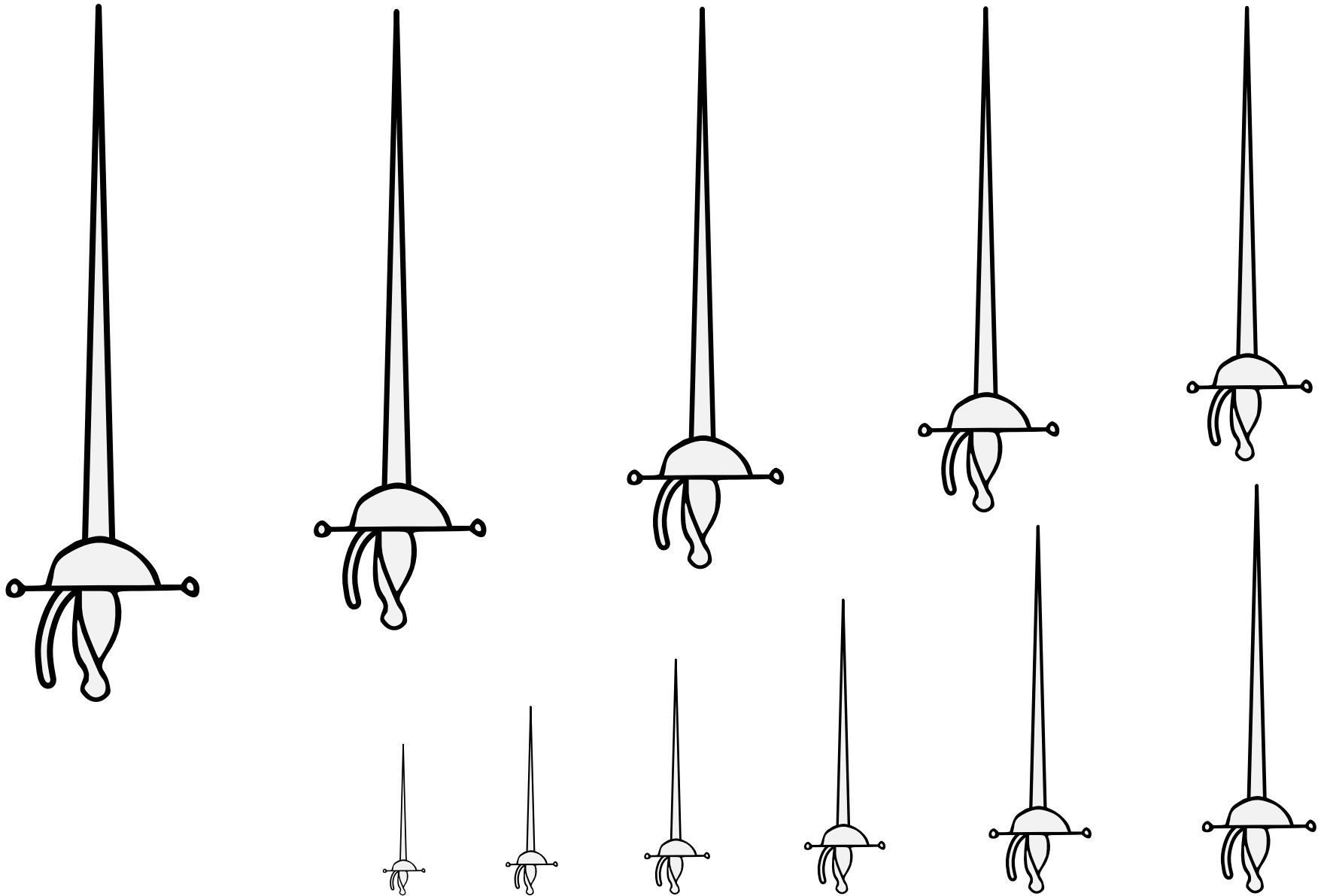

A light sword with a cup hilt and quillons.

Default orientation: palewise, point to chief.

Source: Pennsic Traceable Art. Artist: Roana d'Evreux (attributed).  
Adapted by Mathghamhain Ua Ruadháin.

Rapier, Cup-hilted 21.203

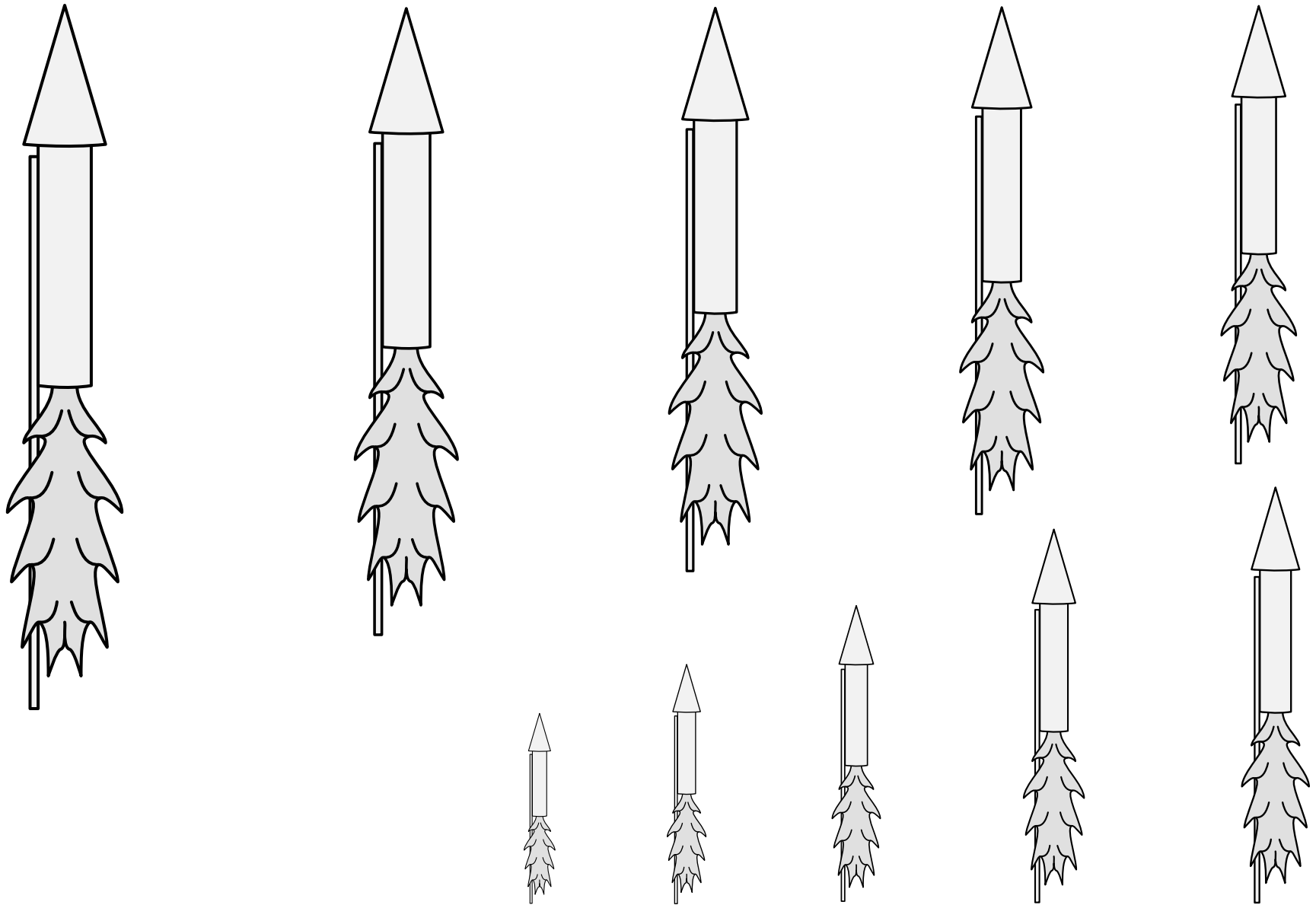

A self-propelled projectile used to attack an enemy at a distance.  
Default orientation: flames to base. No proper coloration.



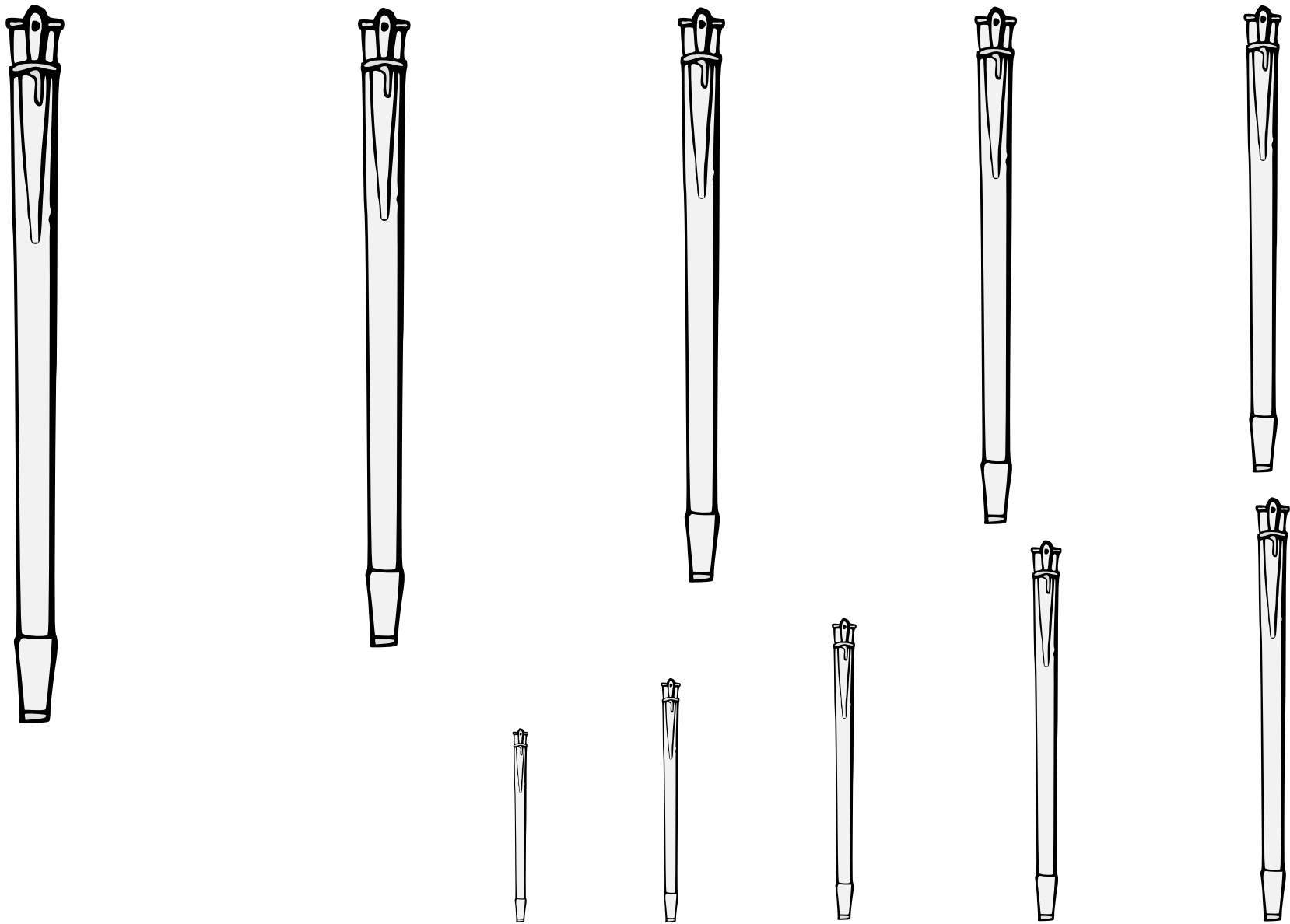

A storage container for a sword.

Default orientation: palewise, opening to chief. No proper coloration.

Source: A Cyclopaedia of Costume. Artist unknown. (Volume I, page 140.)

Scabbard 21.205

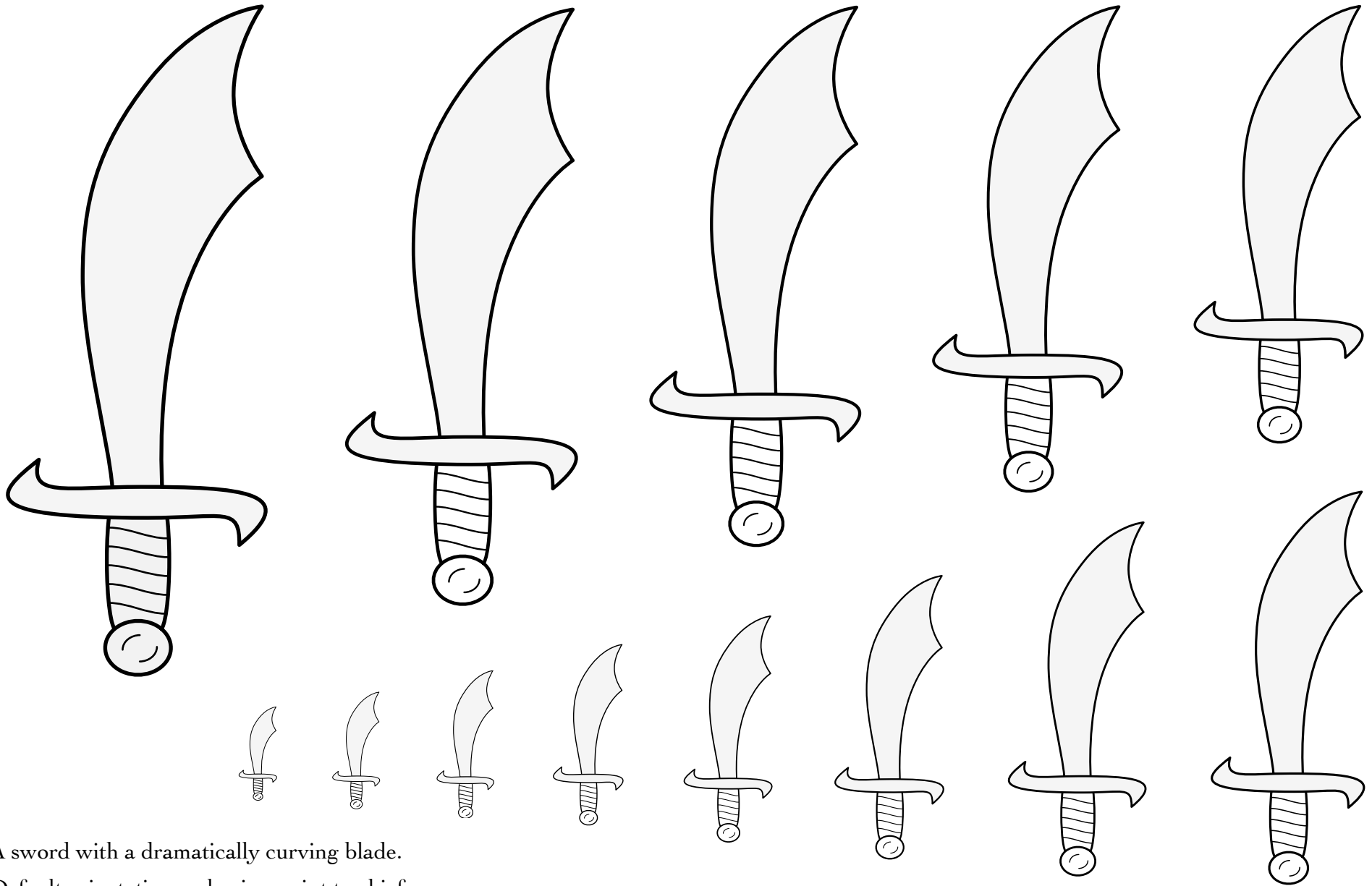

A sword with a dramatically curving blade.

Default orientation: palewise, point to chief.

Proper coloration: blade argent, hilt Or.

Source: Pennsic Traceable Art. Artist unknown.

Adapted by Mathghamhain Ua Ruadháin.

Scimitar (1) 21.206

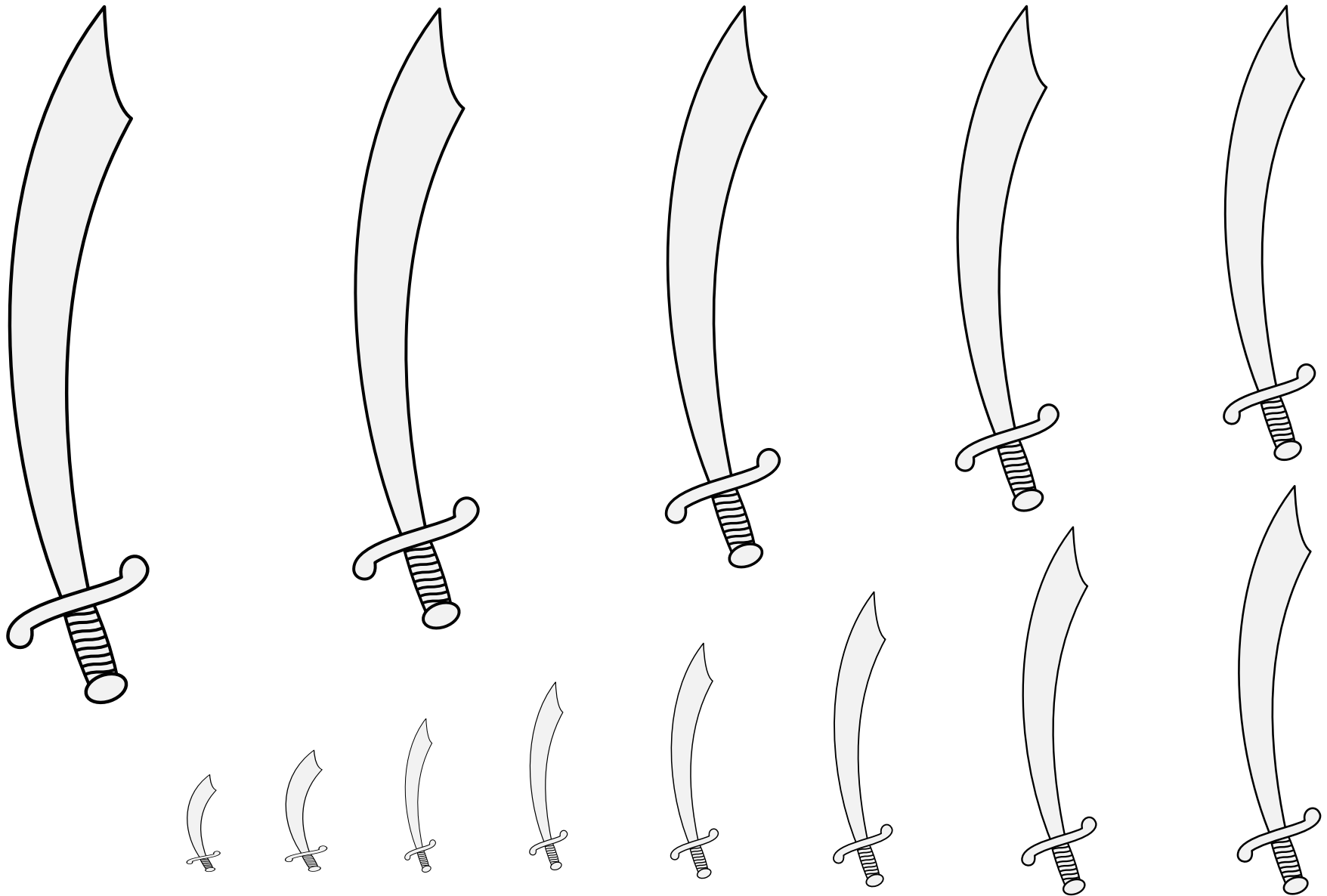

A sword with a dramatically curving blade.

Default orientation: palewise, point to chief.

Proper coloration: blade argent, hilt Or.

Source: SVG Heraldry Components. Artist: Nicholas de Estleche.

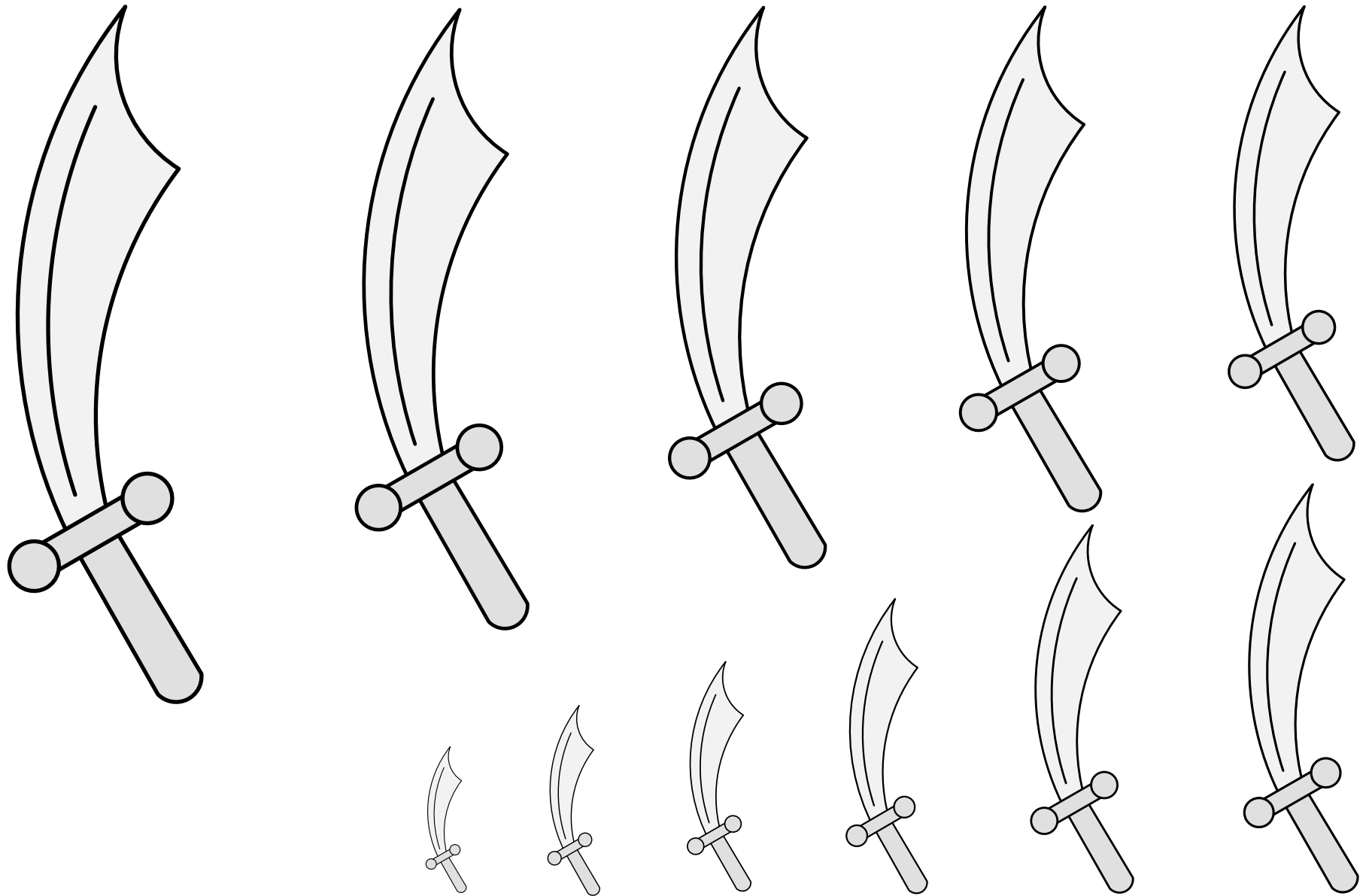

A sword with a dramatically curving blade.

Default orientation: point to chief, cutting to dexter.

Proper coloration: blade argent, hilt Or.

Source: Viking Answer Lady SVG Images For Heraldry. Artist: Gunnvôr silfráhr.

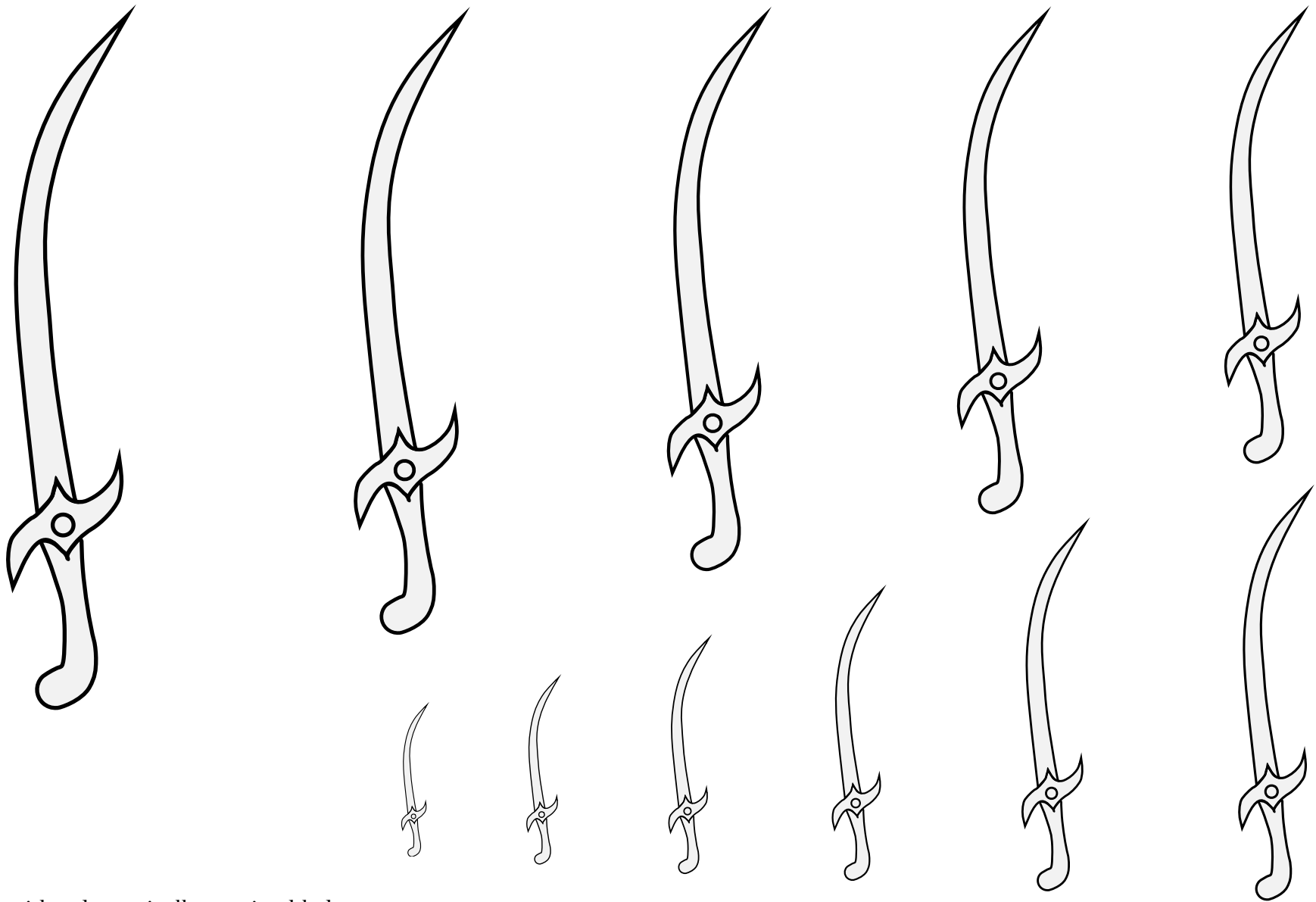

A sword with a dramatically curving blade.

Default orientation: point to chief, cutting to dexter. Proper coloration: blade argent, hilt Or.

This depiction shows a Shamshir sword from Persia.

Source: Pennsic Herald's Point Artists. Artist: Bahja al-Azraq.

**Scimitar (4)** 21.209

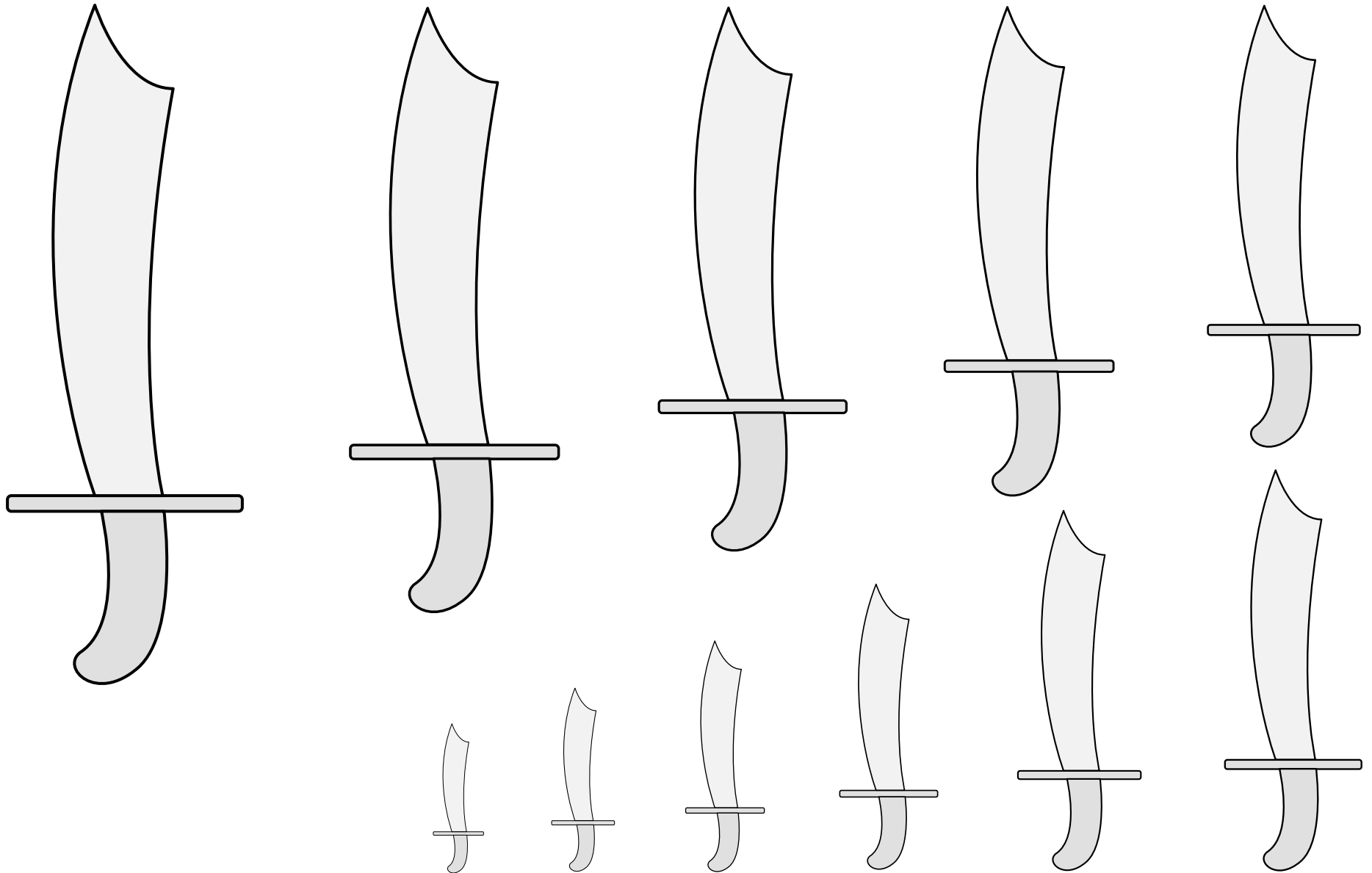

A sword with a dramatically curving blade.

Default orientation: point to chief, cutting to dexter. Proper coloration: blade argent, hilt Or.

Source: Wappenbuch der Arlberg-Bruderschaft.

Artist: Vigil Raber. (Page 836.)

**Scimitar (5)** • 21.210

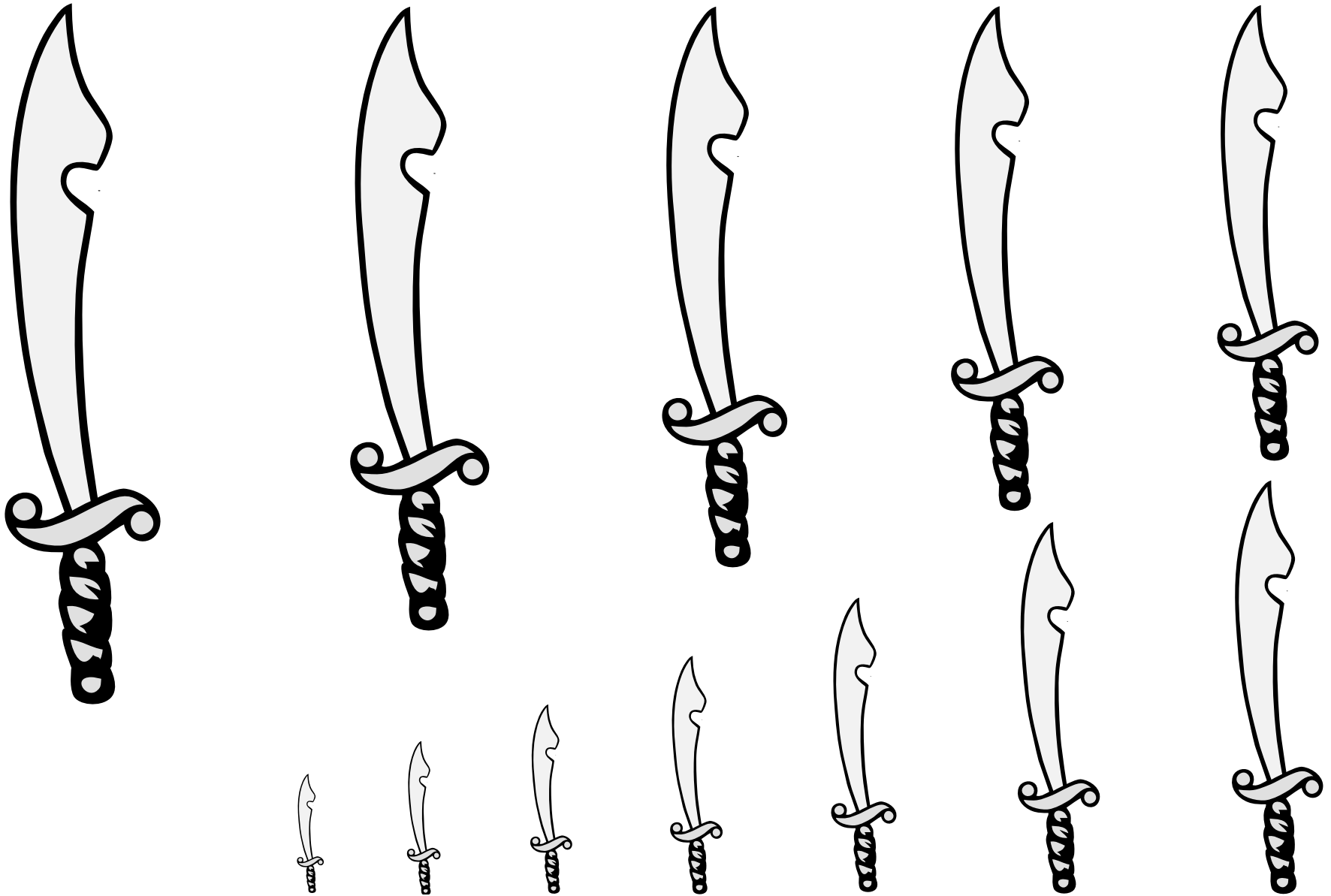

A sword with a dramatically curving blade.

Default orientation: point to chief, cutting to dexter. Proper coloration: blade argent, hilt Or.

Source: The Trade Signs of Essex. Artist unknown.

Scimitar (6) 21.211

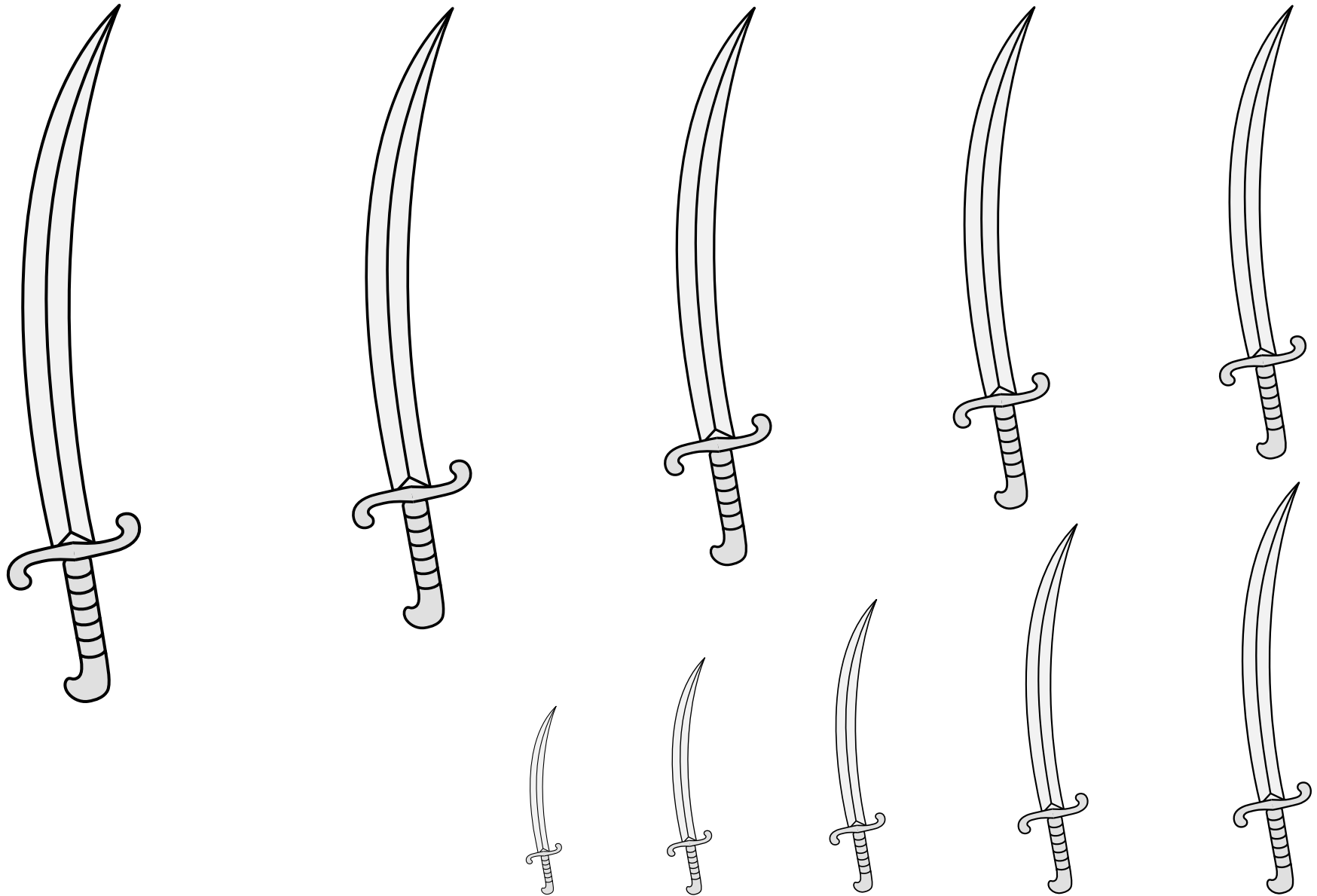

A sword with a dramatically curving blade.

Default orientation: point to chief, cutting to dexter. Proper coloration: blade argent, hilt Or.

Source: WappenWiki. Artist: Joakim Spuller.

**Scimitar (7)** 21.212



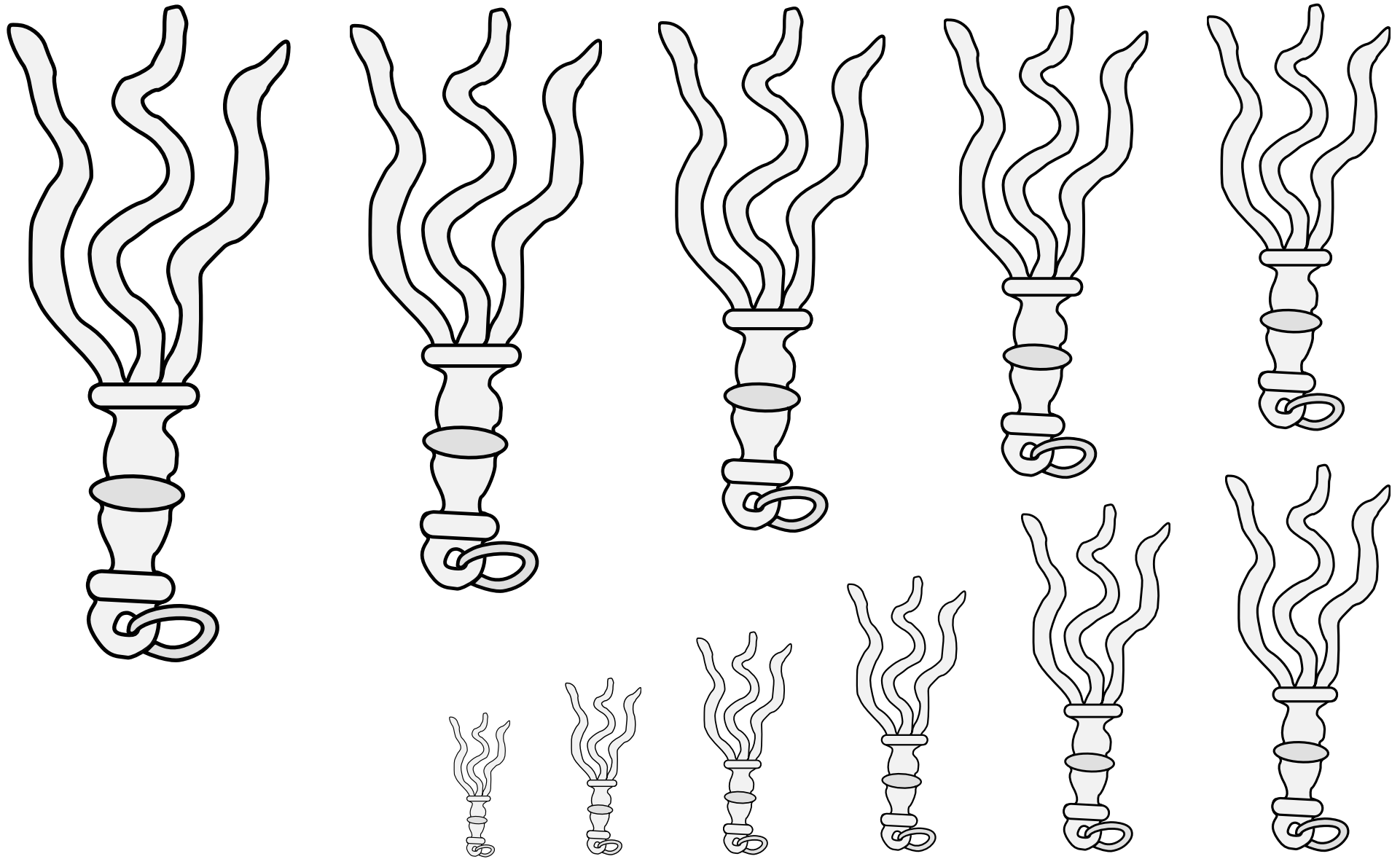

A whip with multiple strands used to punish people.

Default orientation: handle to base. No proper coloration.

Source: Priorista di Giuliano de' Ricci. Artist unknown. (Vol. I, folio 56v, arms of Ferra.)

**Scourge (1)** 21.213

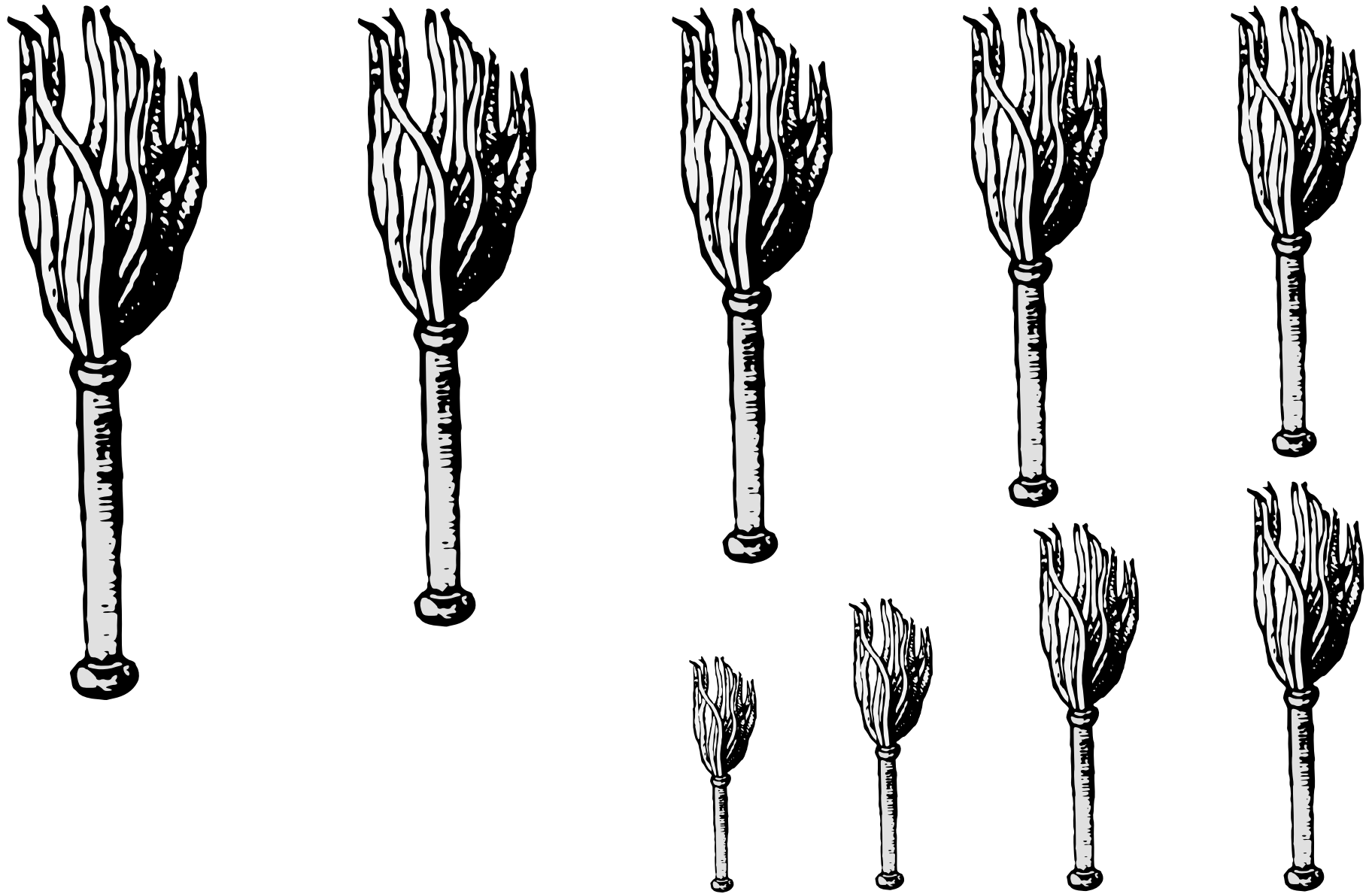

A whip with multiple strands used to punish people.  
Default orientation: handle to base. No proper coloration.  
Source: Le Blason Des Armoiries. Artist: Jérôme de Bara. (Page 199.)

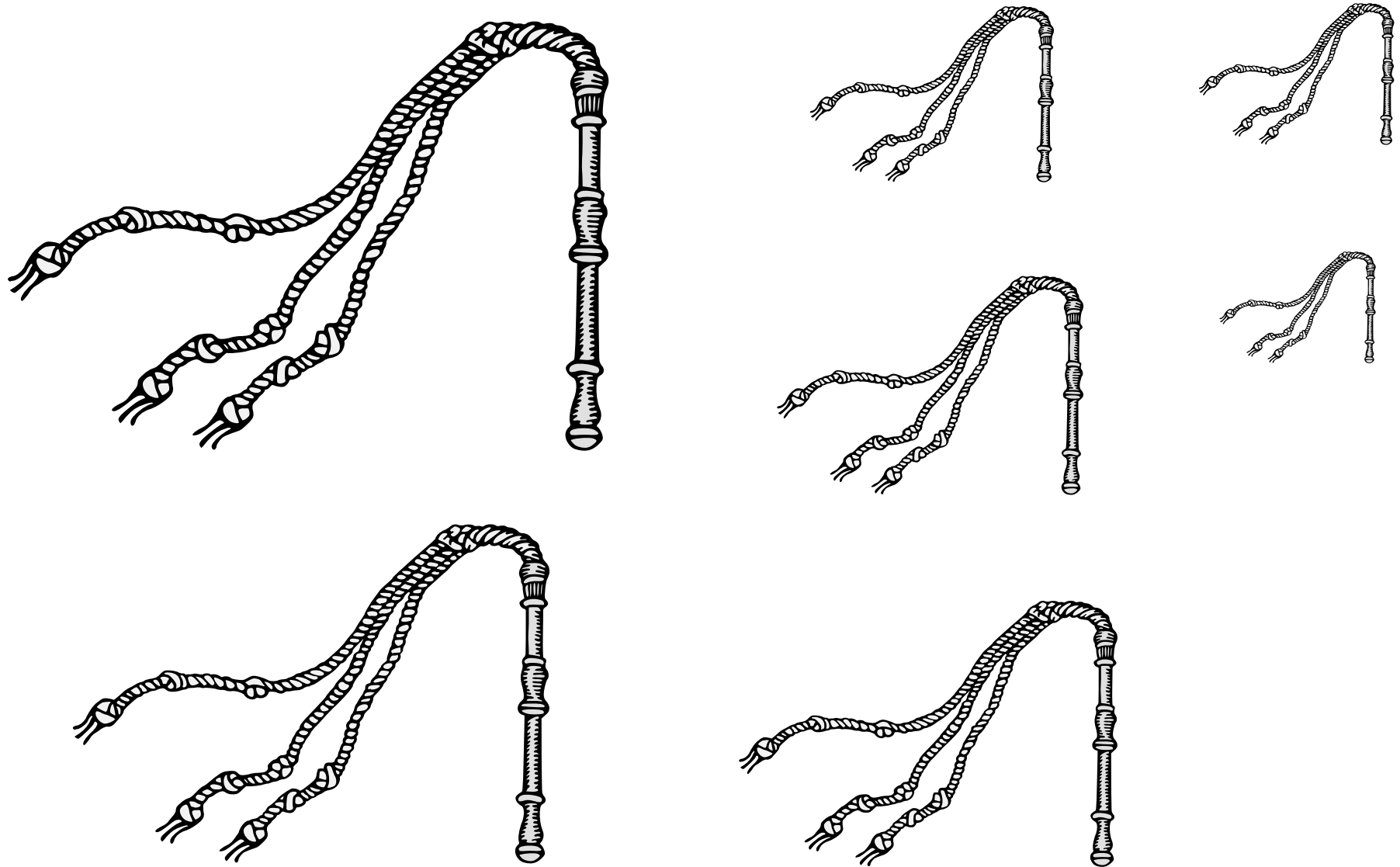

A whip with multiple strands used to punish people.  
Default orientation: handle to base. No proper coloration.  
Artist: Jessimond of Emerickeskepe.



An agricultural implement mounted to a long haft for military purposes.  
Default orientation: point to chief. No proper coloration.  
Adapted from a photograph of Polish scythemen during the insurrection of 1863.

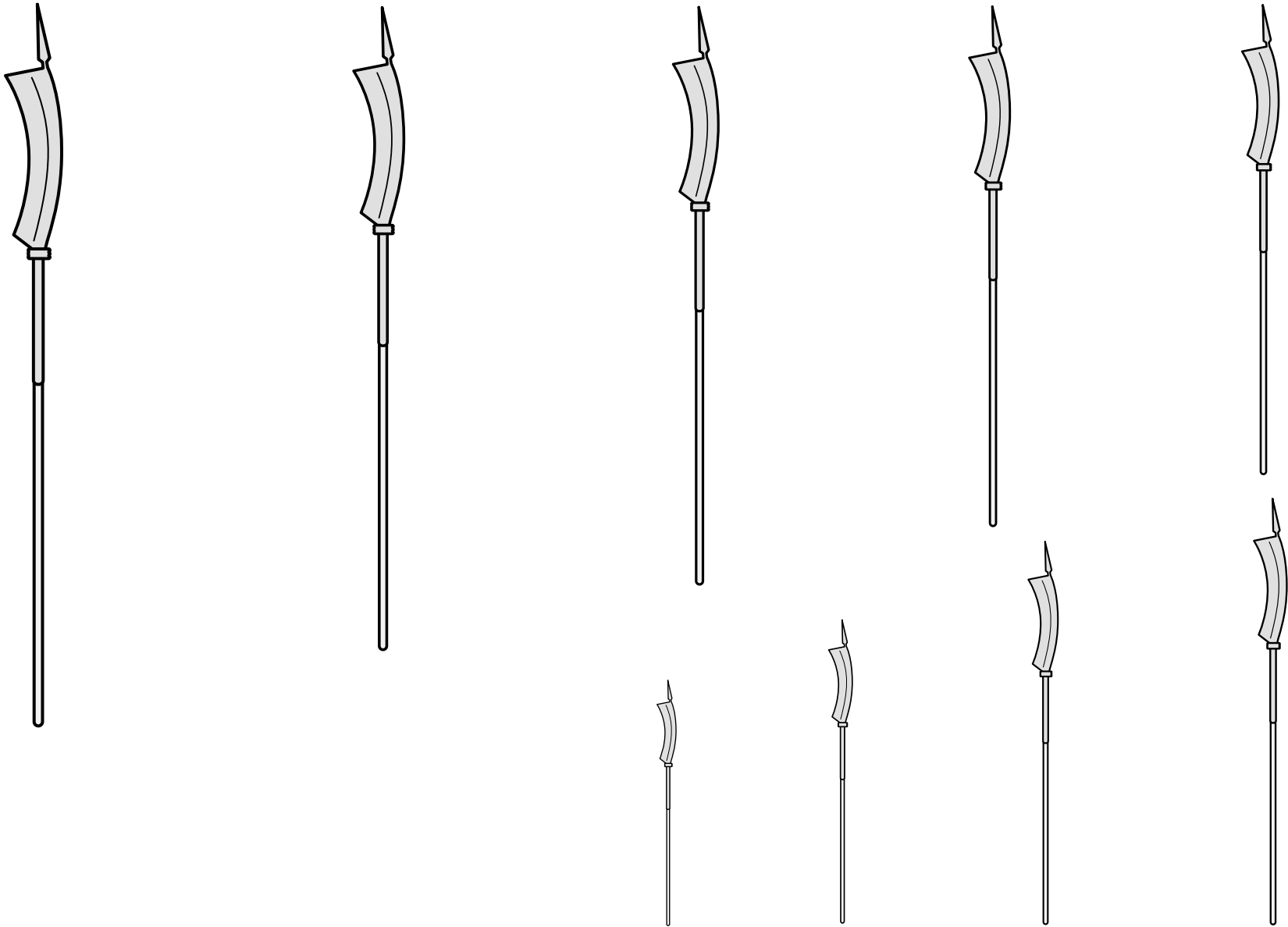

An agricultural implement mounted to a long haft for military purposes.

Default orientation: point to chief. No proper coloration.

Source: Krótka Nauka o Kosach i Pikach. Artist unknown.

**Scythe, War- (2) • 21.217**

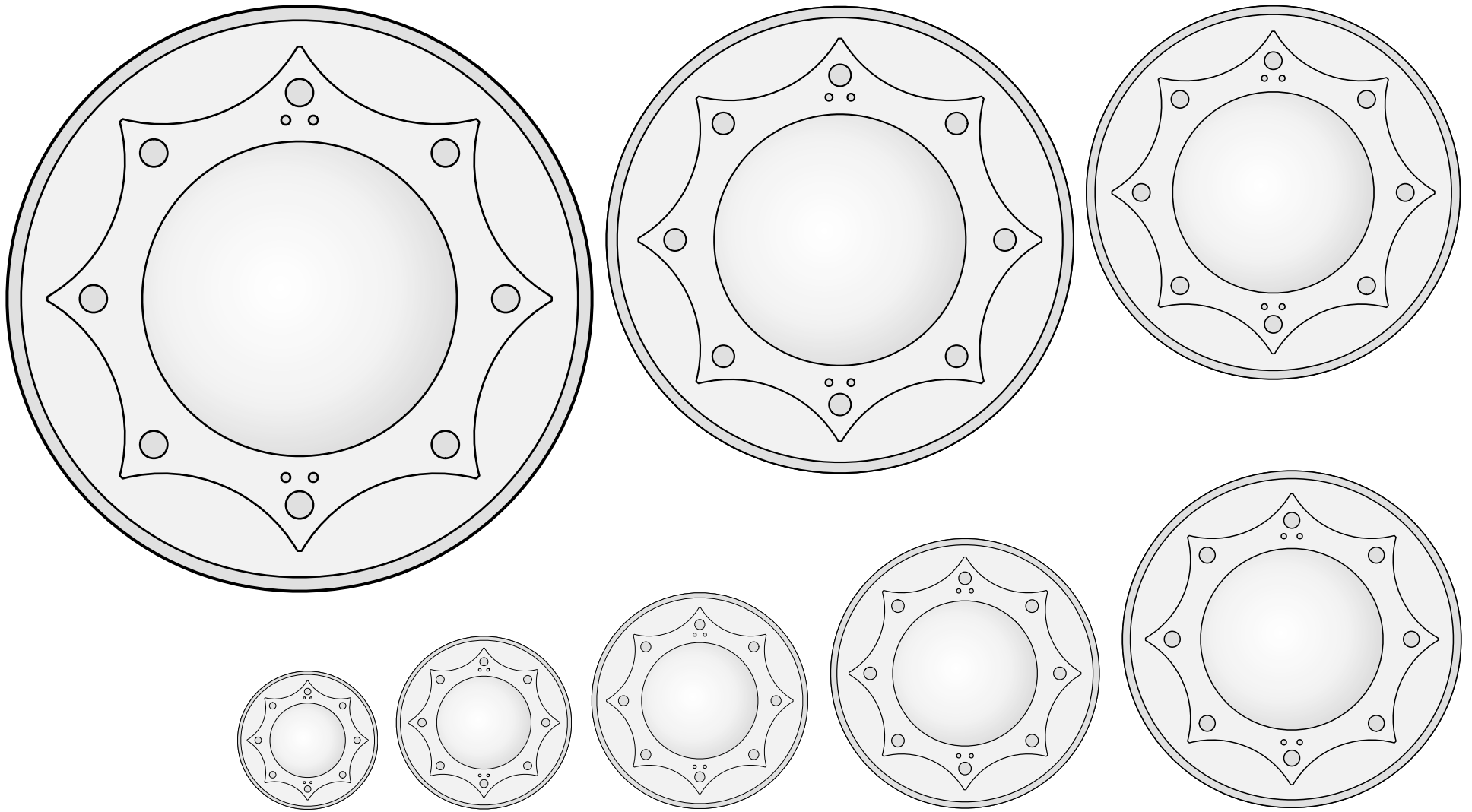

A portable defensive barrier for use in combat.  
Adapted from images of Renaissance-era small metal bucklers.

**Shield, Buckler** 21.218

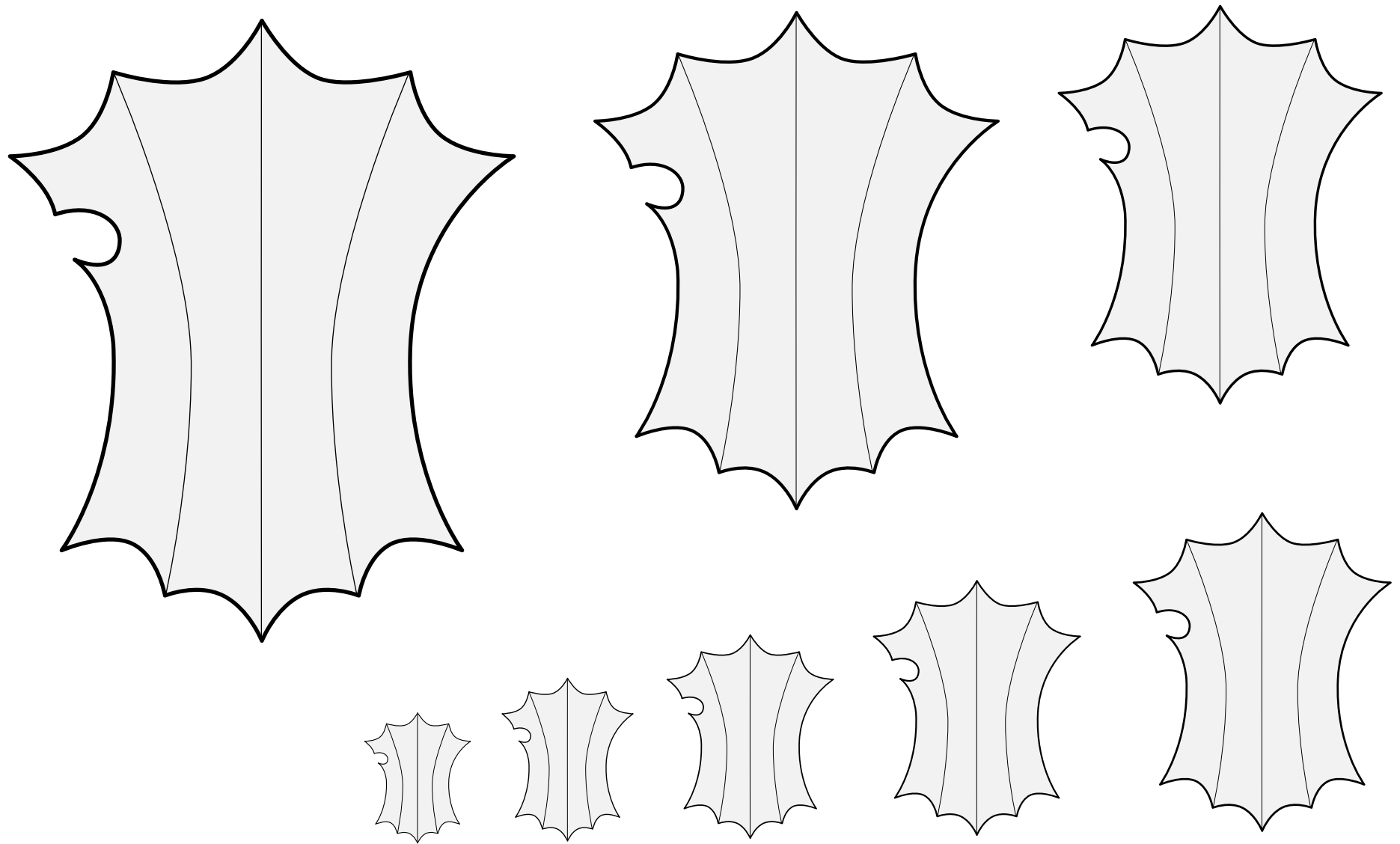

A portable defensive barrier for use in combat.

# Shield, German Tournament 21.219

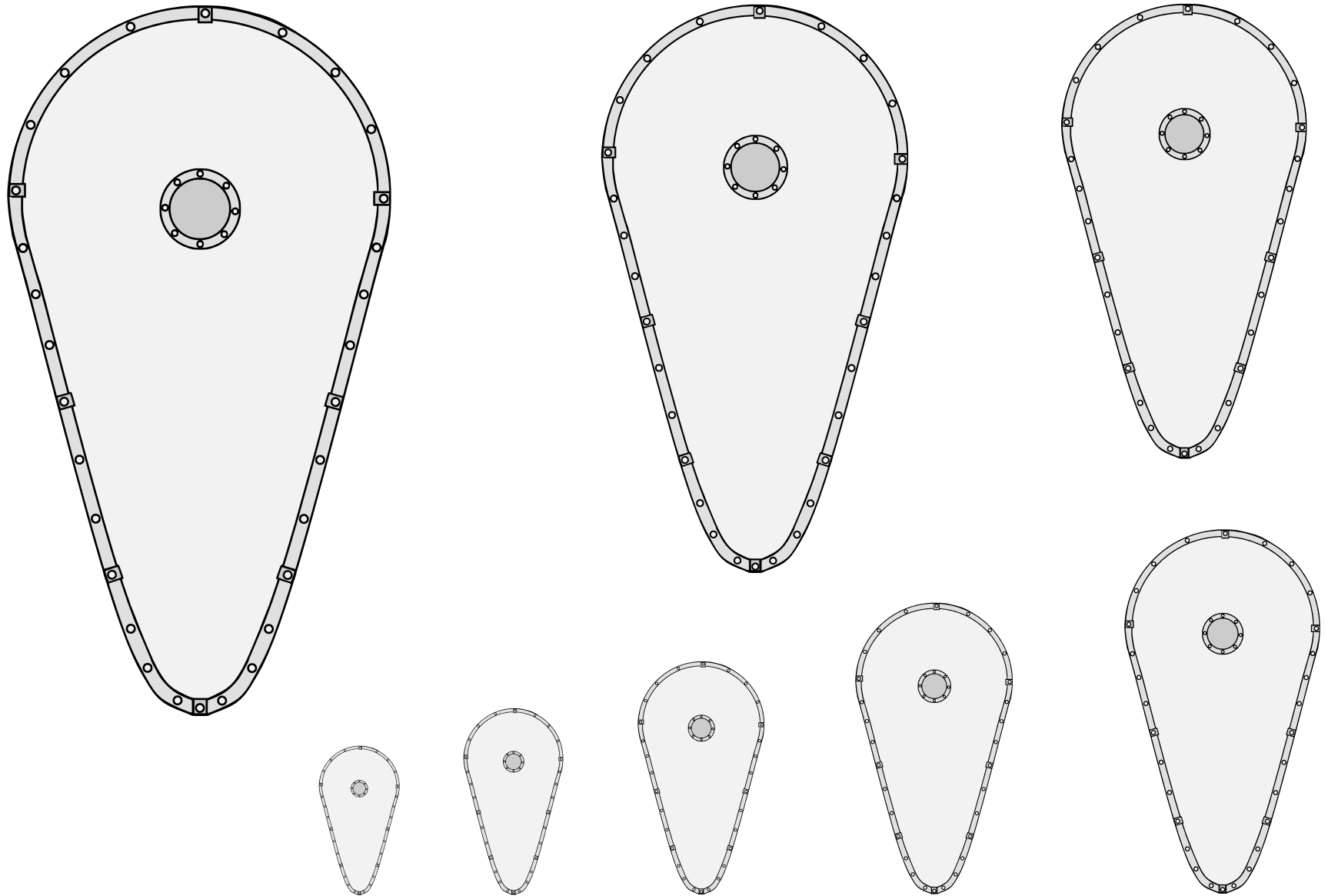

A portable defensive barrier for use in combat.  
Artist: Jessimond of Emerickeskepe.

Shield, Kite 🐉 21.220



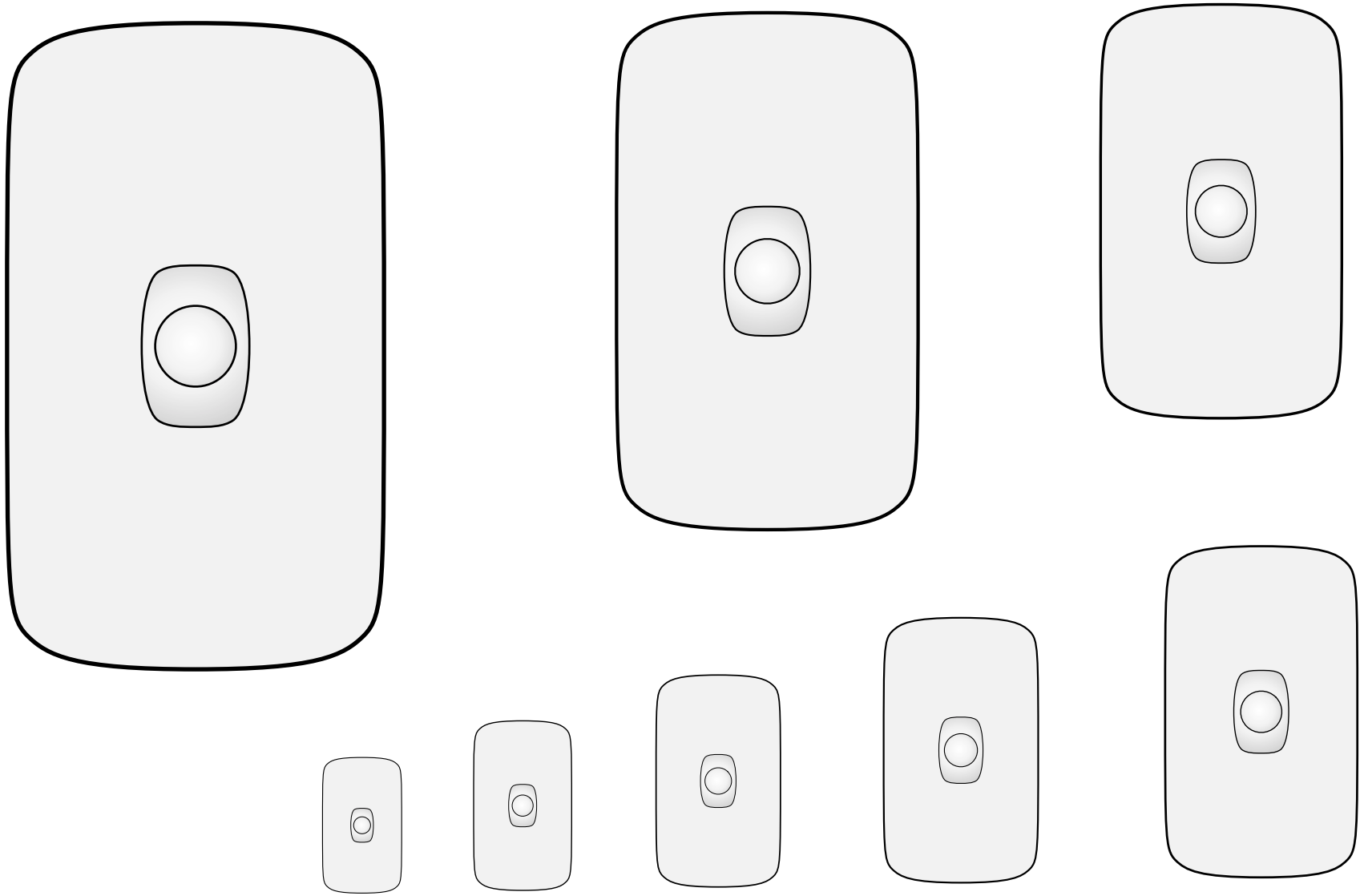

A portable defensive barrier for use in combat.

# Shield, Roman Scutum 🍷 21.221

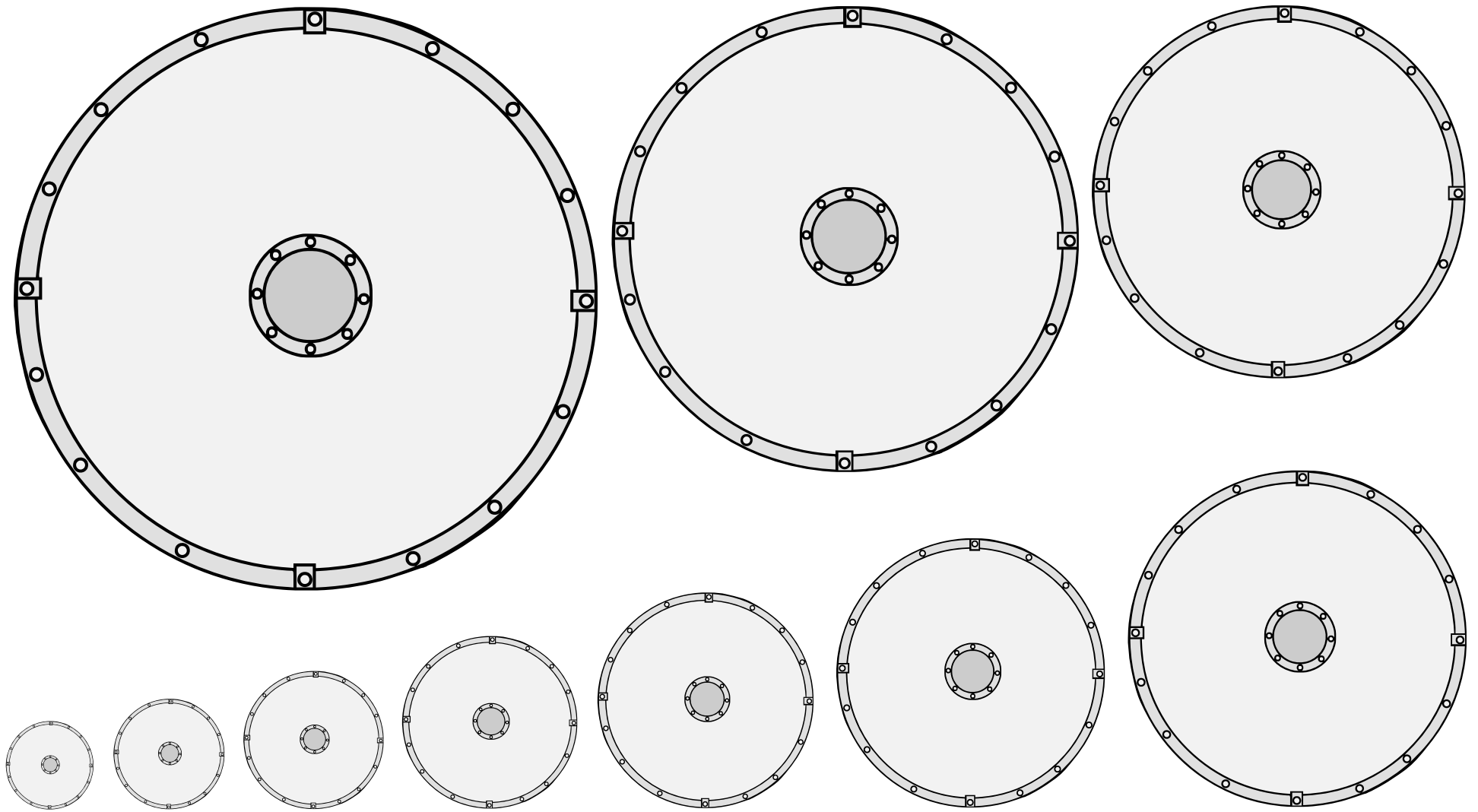

A portable defensive barrier for use in combat.  
Artist: Jessimond of Emerickeskepe.

# Shield, Round Metal 21.222

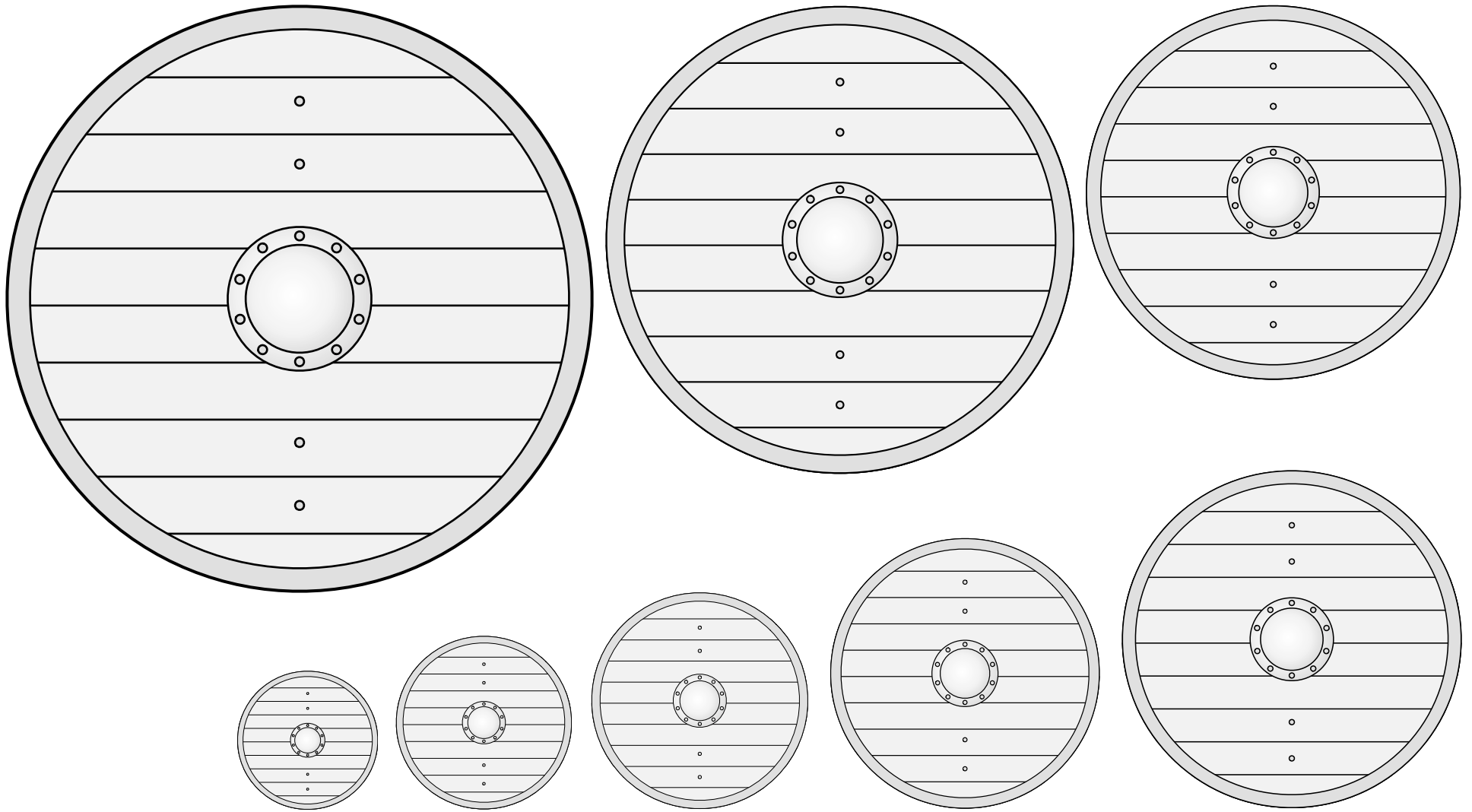

A portable defensive barrier for use in combat.  
Adapted from images of migration-period plank shields.

## Shield, Round Wooden 21.223

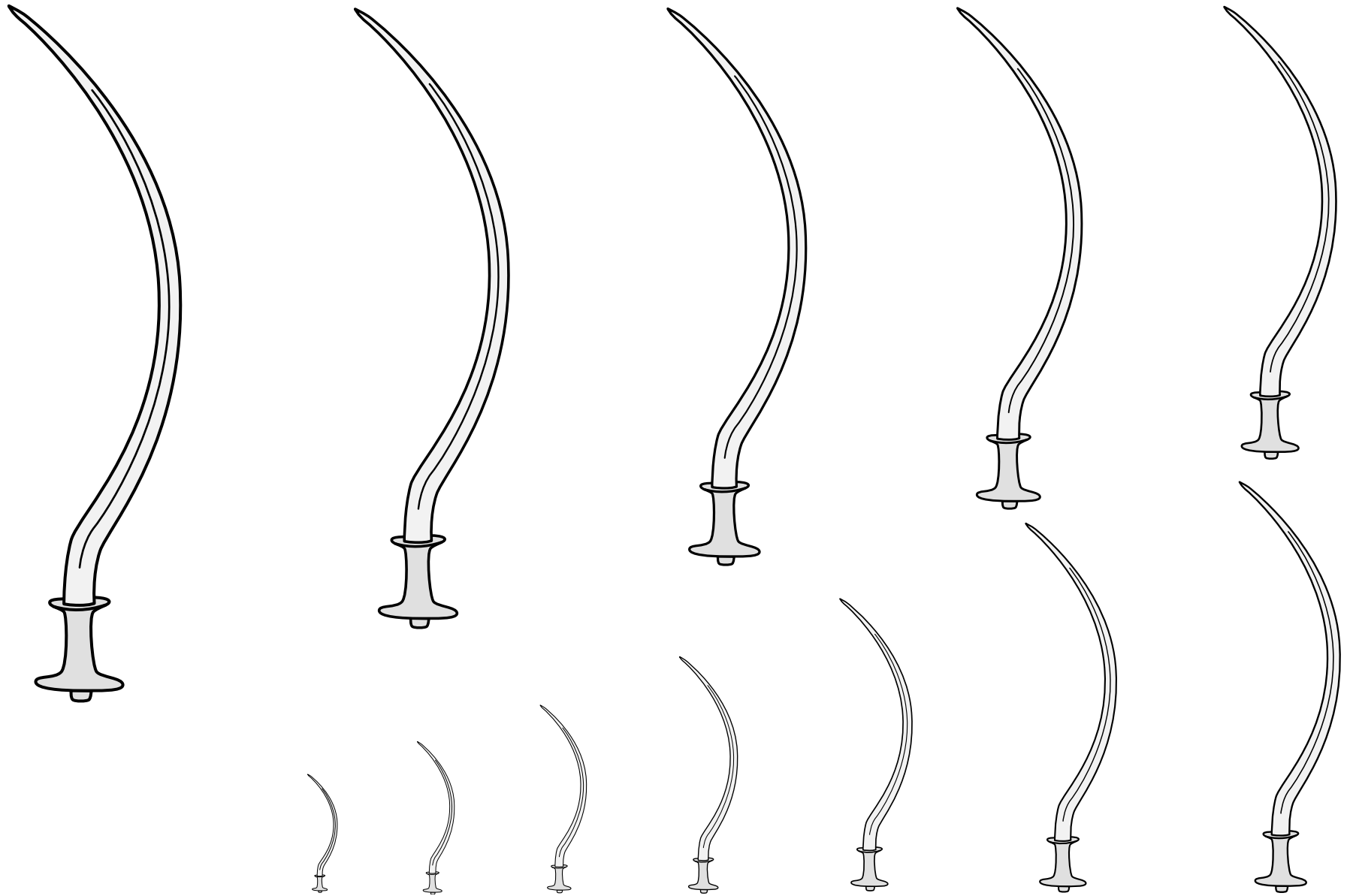

A curving sickle-like sword originating in East Africa.  
Default orientation: point to chief. Proper coloration: blade argent, hilt Or.

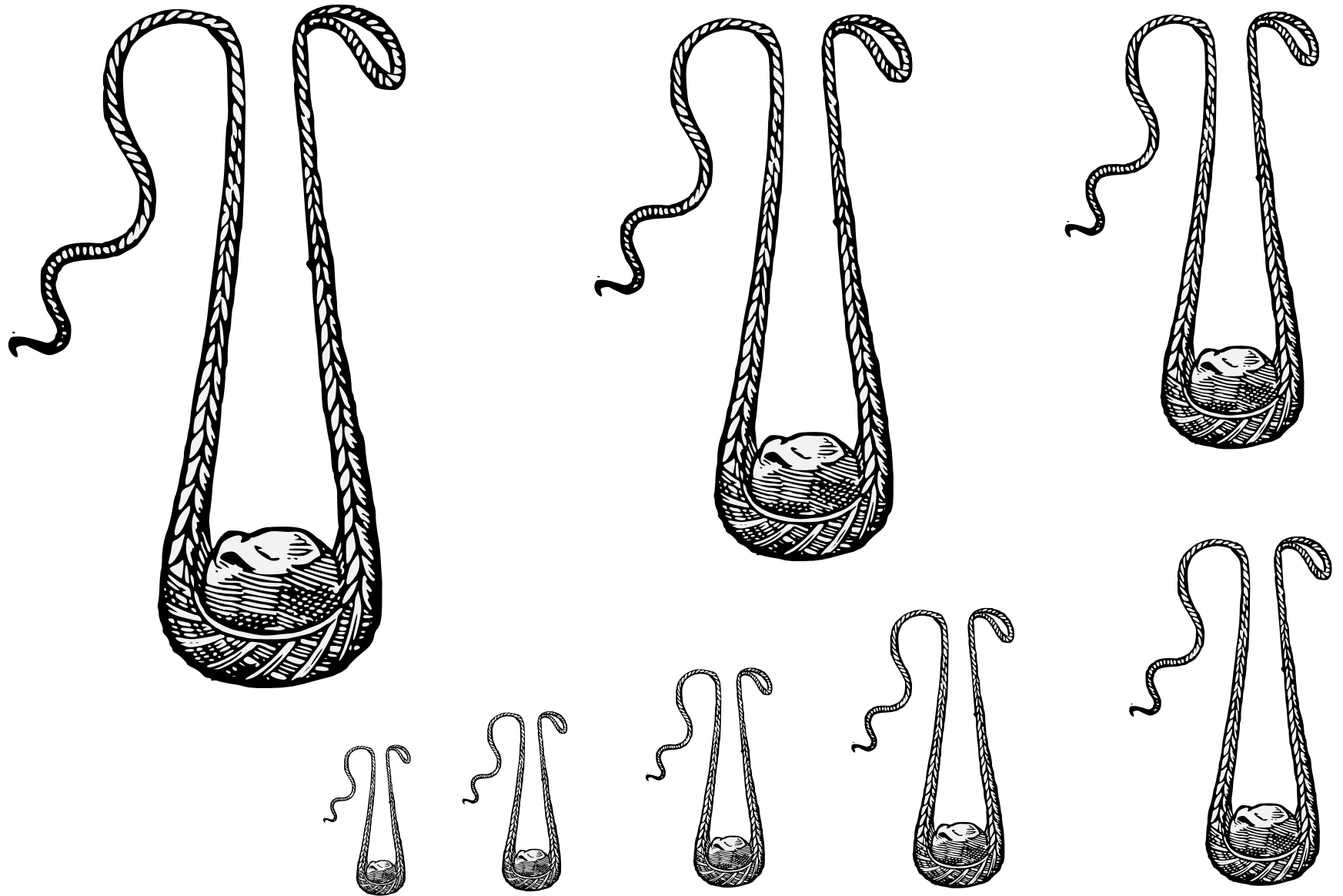

A flexible projectile launcher of antiquity.

Default orientation: stone to base. No proper coloration.

Source: Le Blason Des Armoiries. Artist: Jérôme de Bara.

Sling and Stone (1) 21.225

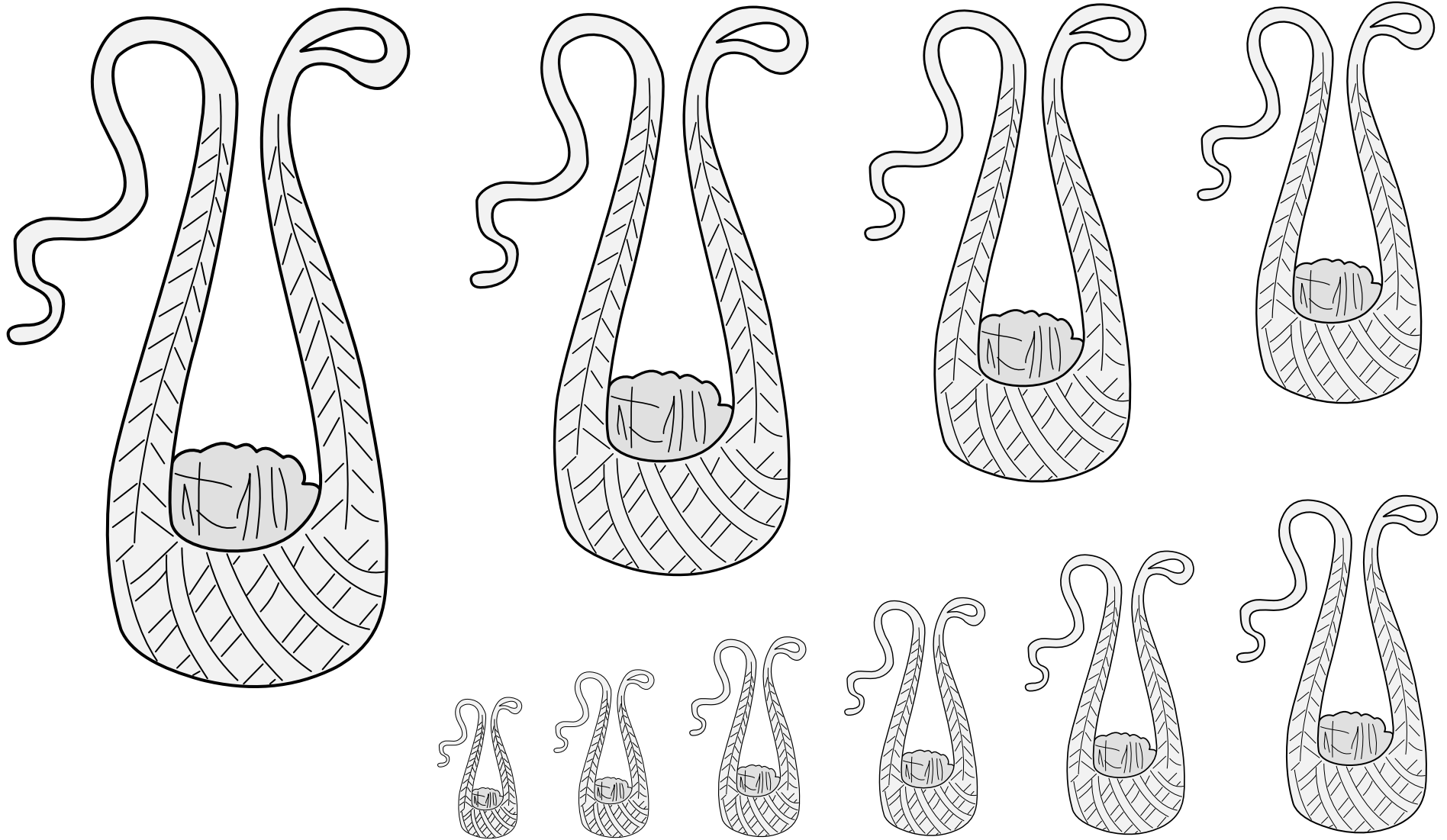

A flexible projectile launcher of antiquity.

Default orientation: stone to base. No proper coloration.

Source: A Display of Heraldry. Artist: John Guillim.  
(Manuscript folio 94v.) Adapted by Iago ab Adam.

**Sling and Stone (2)** 21.226

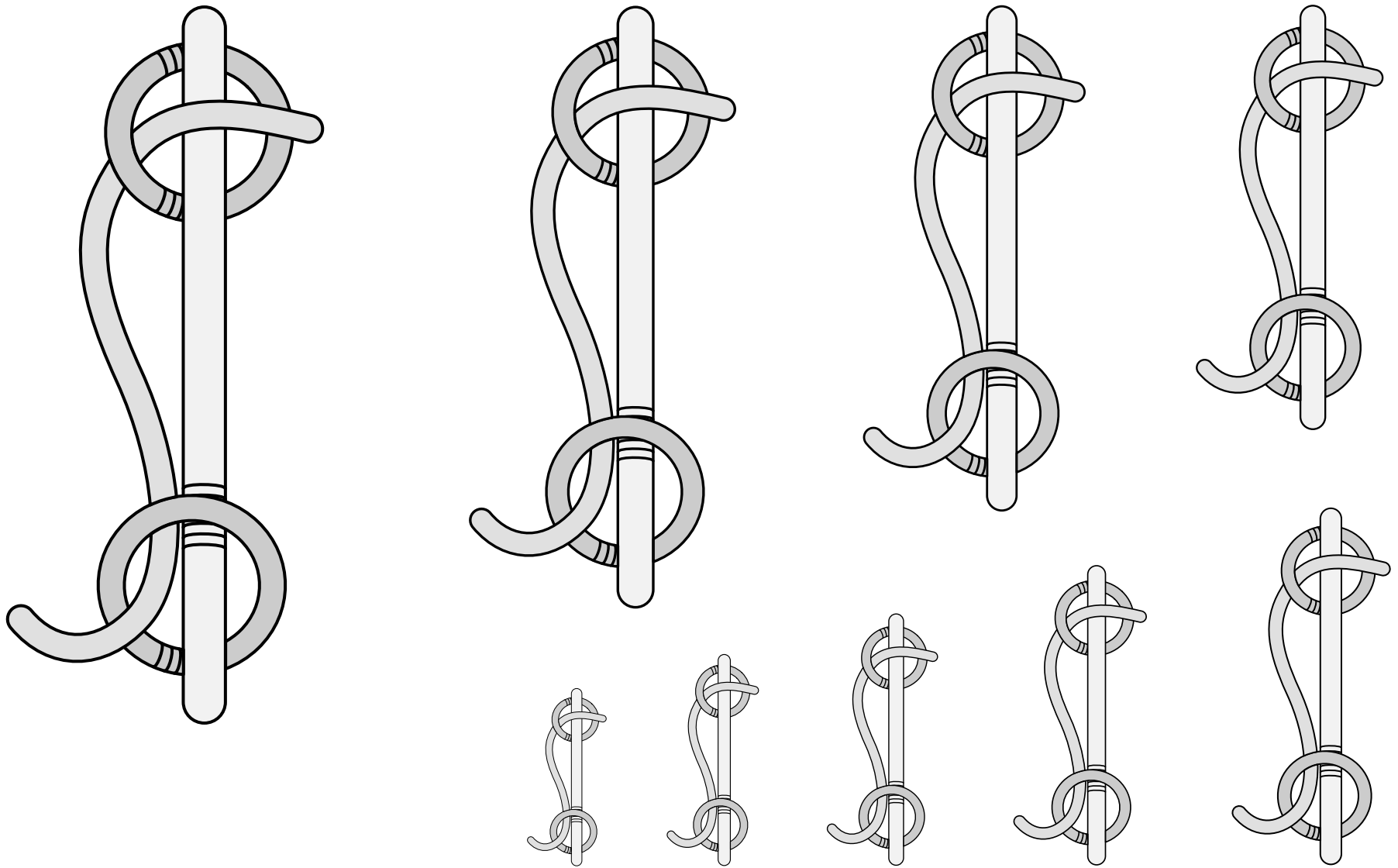

A flexible projectile launcher of antiquity.

Default orientation: stone to base. Proper coloration unknown.

Source: University of Victoria Ms. Brown.Eng.2.  
Artist unknown. (Page 204, arms of Carden.)

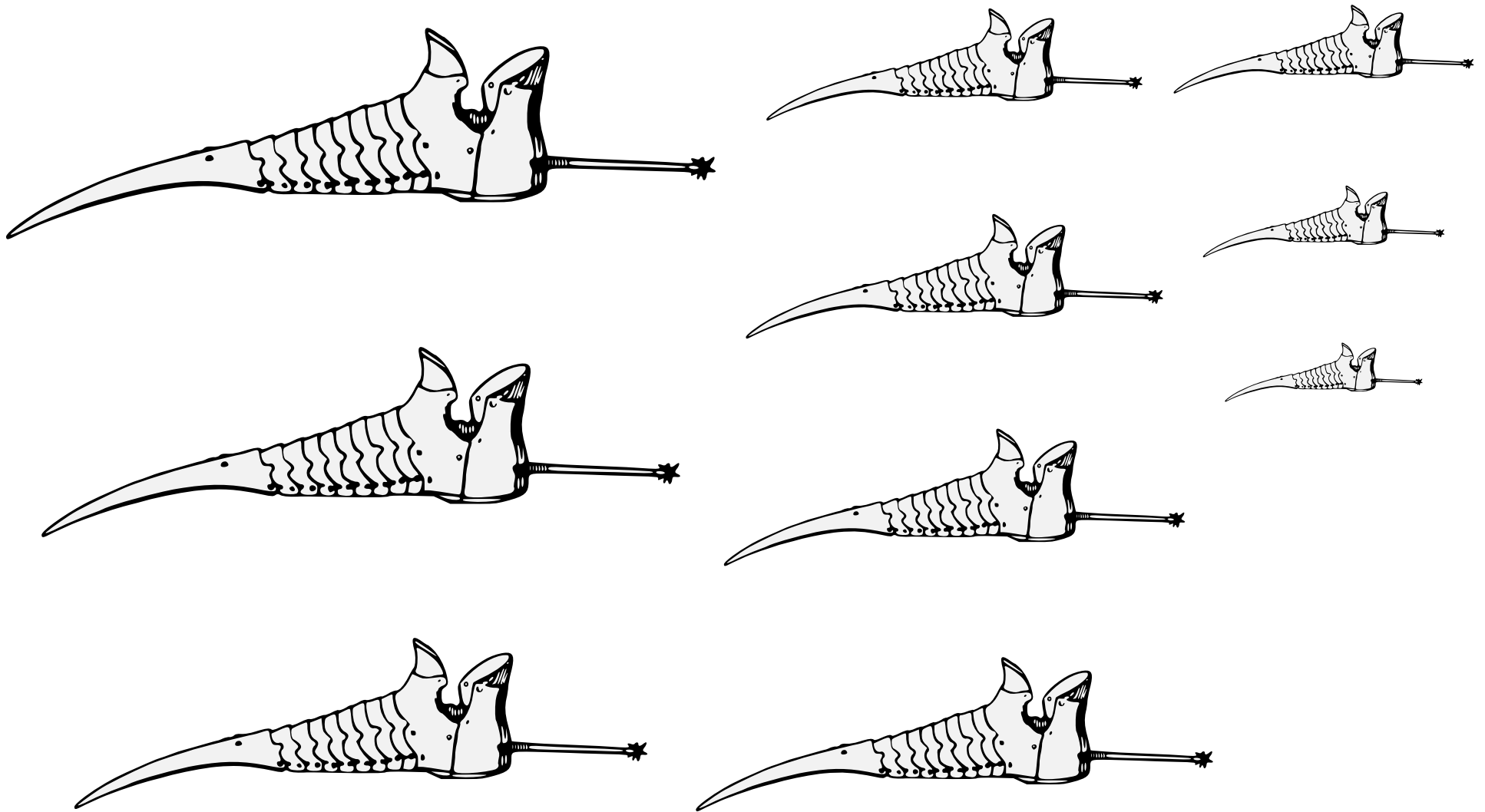

A pointy-toed piece of armor for the foot developed in the fourteenth century.

Default orientation: fesswise, pointing to dexter. No proper coloration.

Source: A Cyclopedia of Costume. Artist unknown. (Volume I, page 473.)



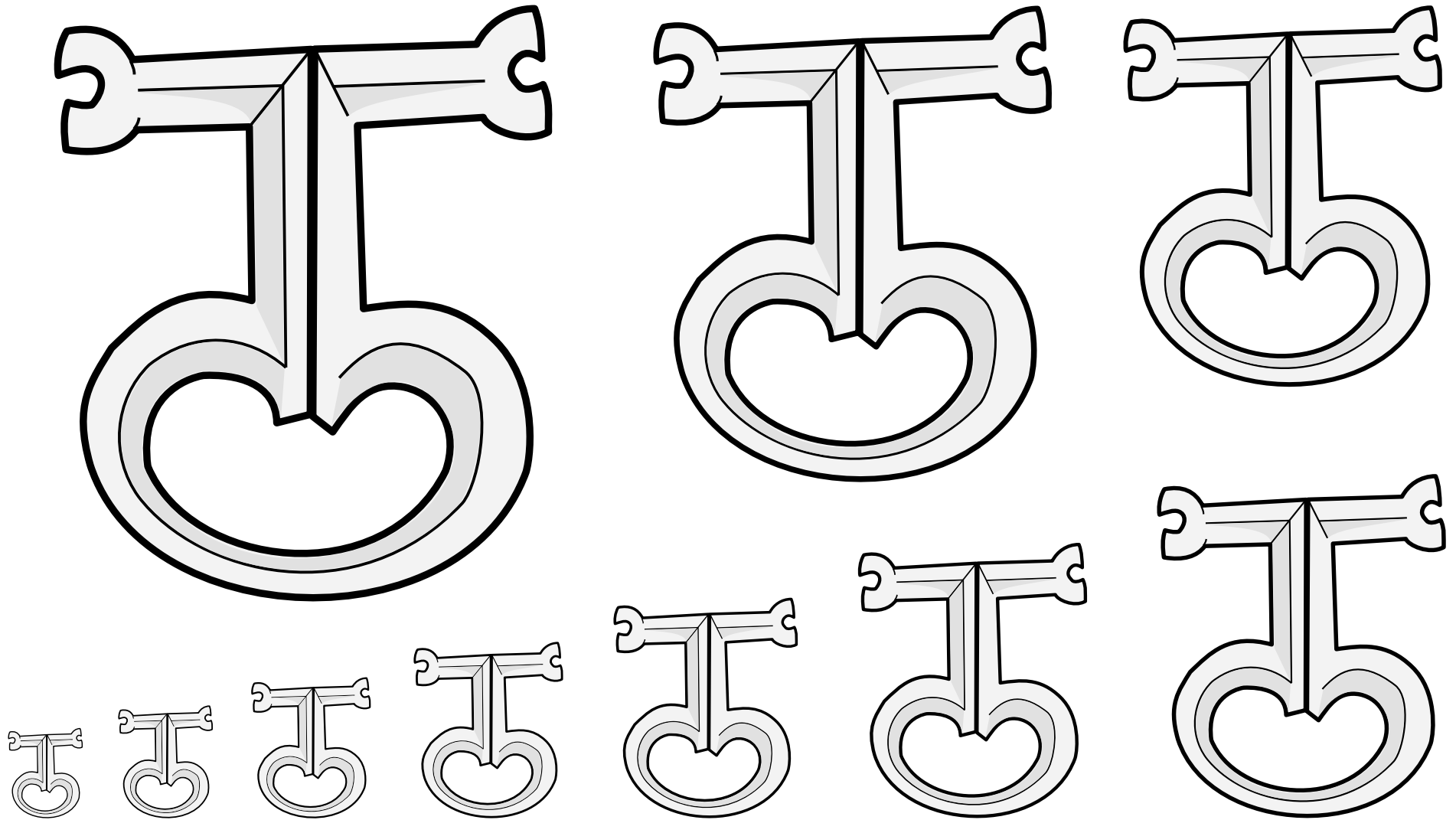

A tool used to span a crossbow.

Default orientation: hooks to chief. No proper coloration.

Source: Die Luzerner Stadtansicht von Martin Martini 1597.  
(Page 171.) Artist unknown. Adapted by Iago ab Adam.

Spanning Iron • 21.229

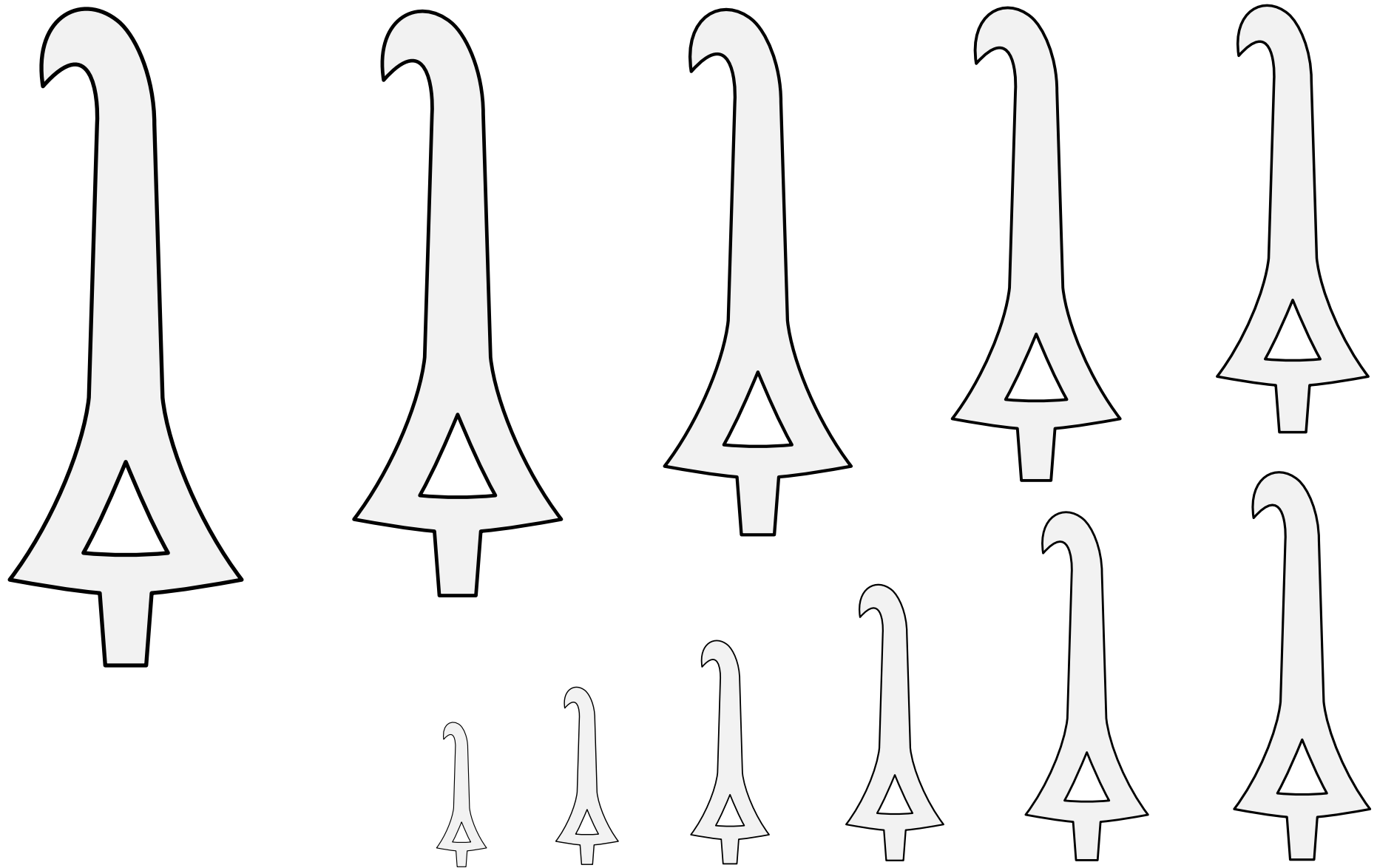

A long hook used to span a crossbow.

Default orientation: hook to chief, pointing to dexter. No proper coloration.

Source: Botenbuch der Bruderschaft St. Christoph auf dem Arlberg.  
Artist unknown. Adapted by Iago ab Adam.

**Spanning Hook** • 21.230

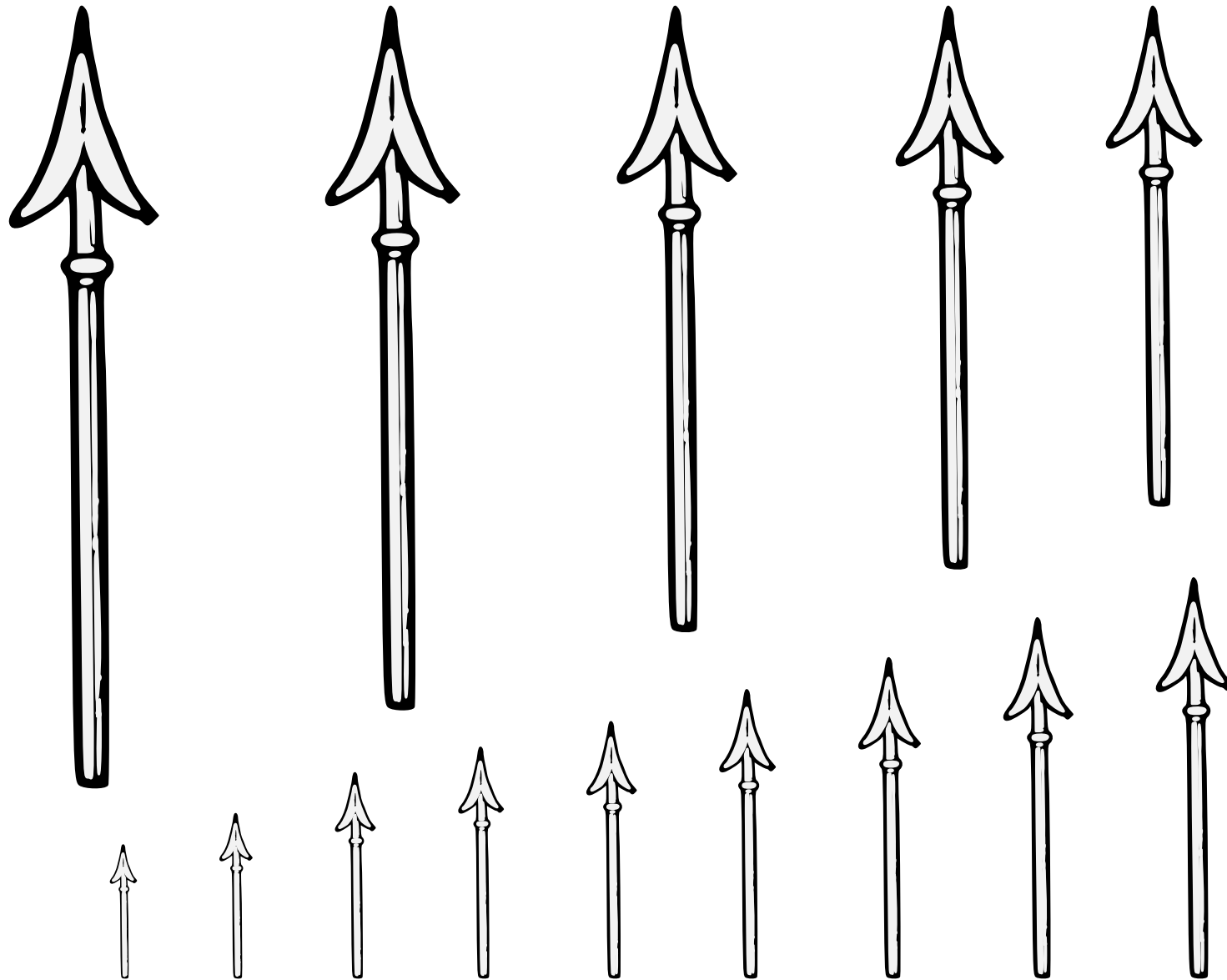

A weapon built from a wooden shaft with a small blade at the tip. A very long spear may be blazoned a pike.

Default orientation: point to chief. No proper coloration.

Source: A Complete Guide to Heraldry. Artist: Graham Johnston.

**Spear (1)** • 21.231

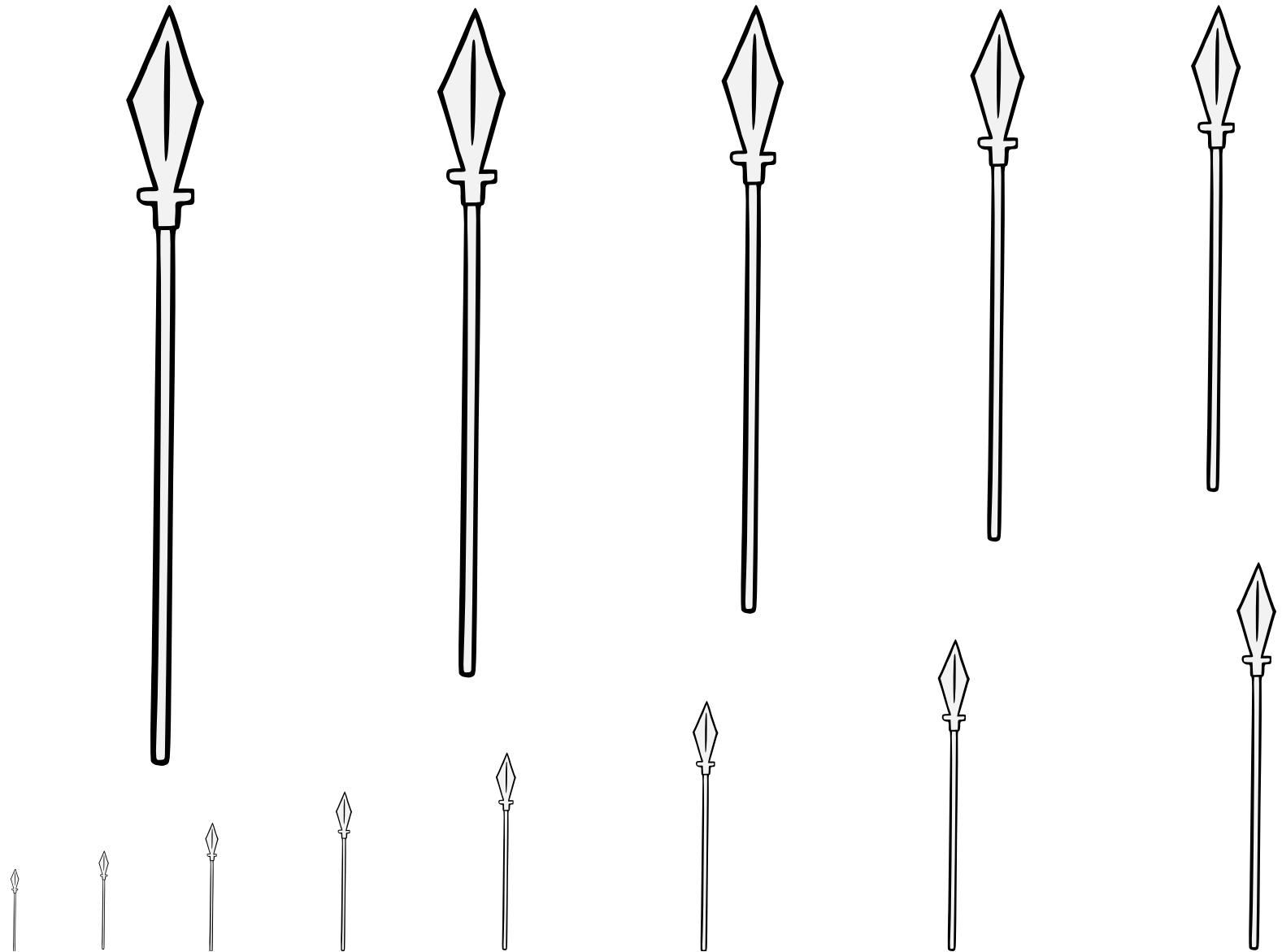

A weapon built from a wooden shaft with a small blade at the tip. A very long spear may be blazoned a pike.

Default orientation: point to chief. No proper coloration.

Source: Pennsic Traceable Art. Artist: Roana d'Evreux.

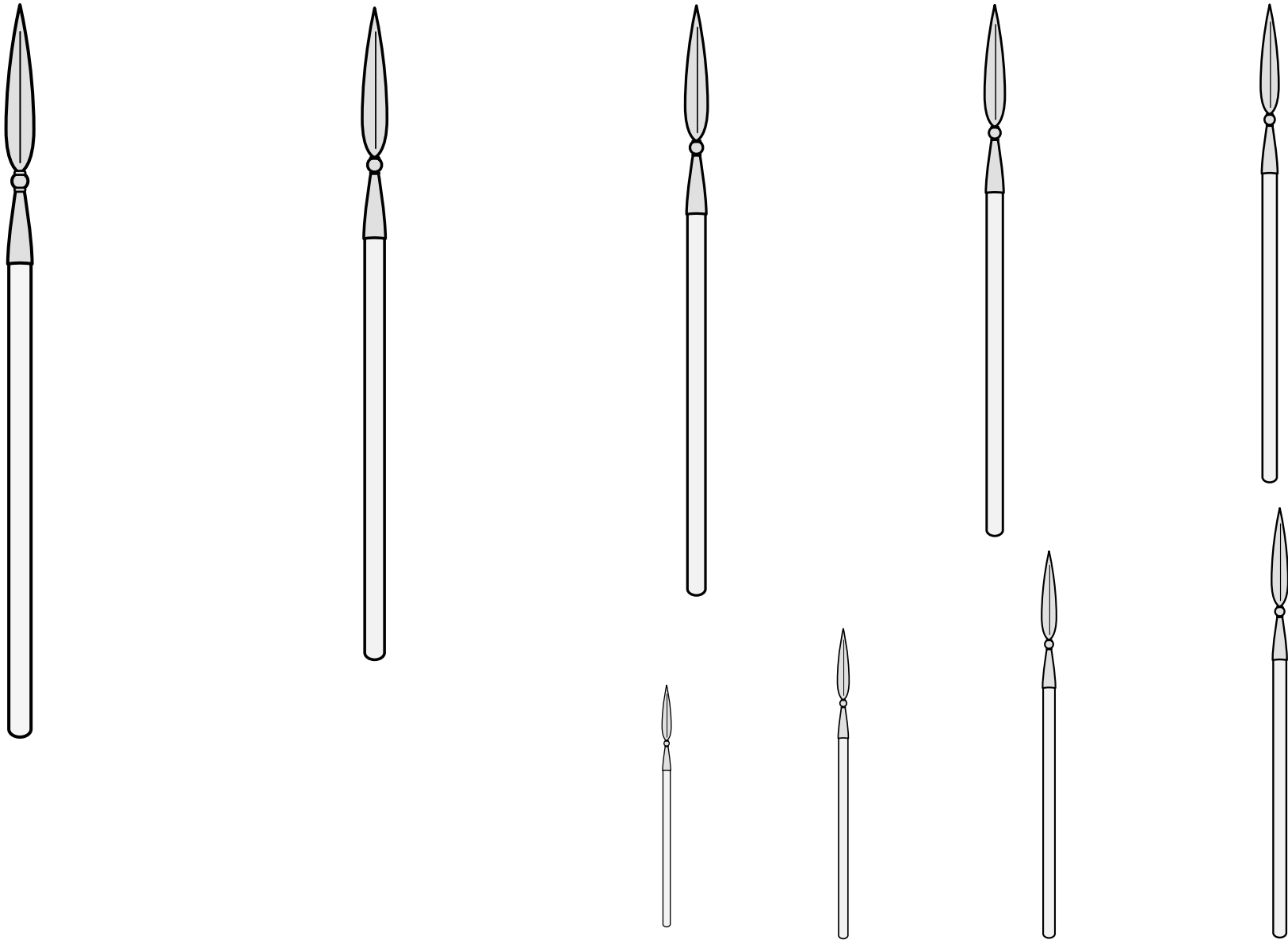

A weapon built from a wooden shaft with a small blade at the tip.  
A very long spear may be blazoned a pike.  
Default orientation: point to chief. No proper coloration.

**Spear (3)** 21.233

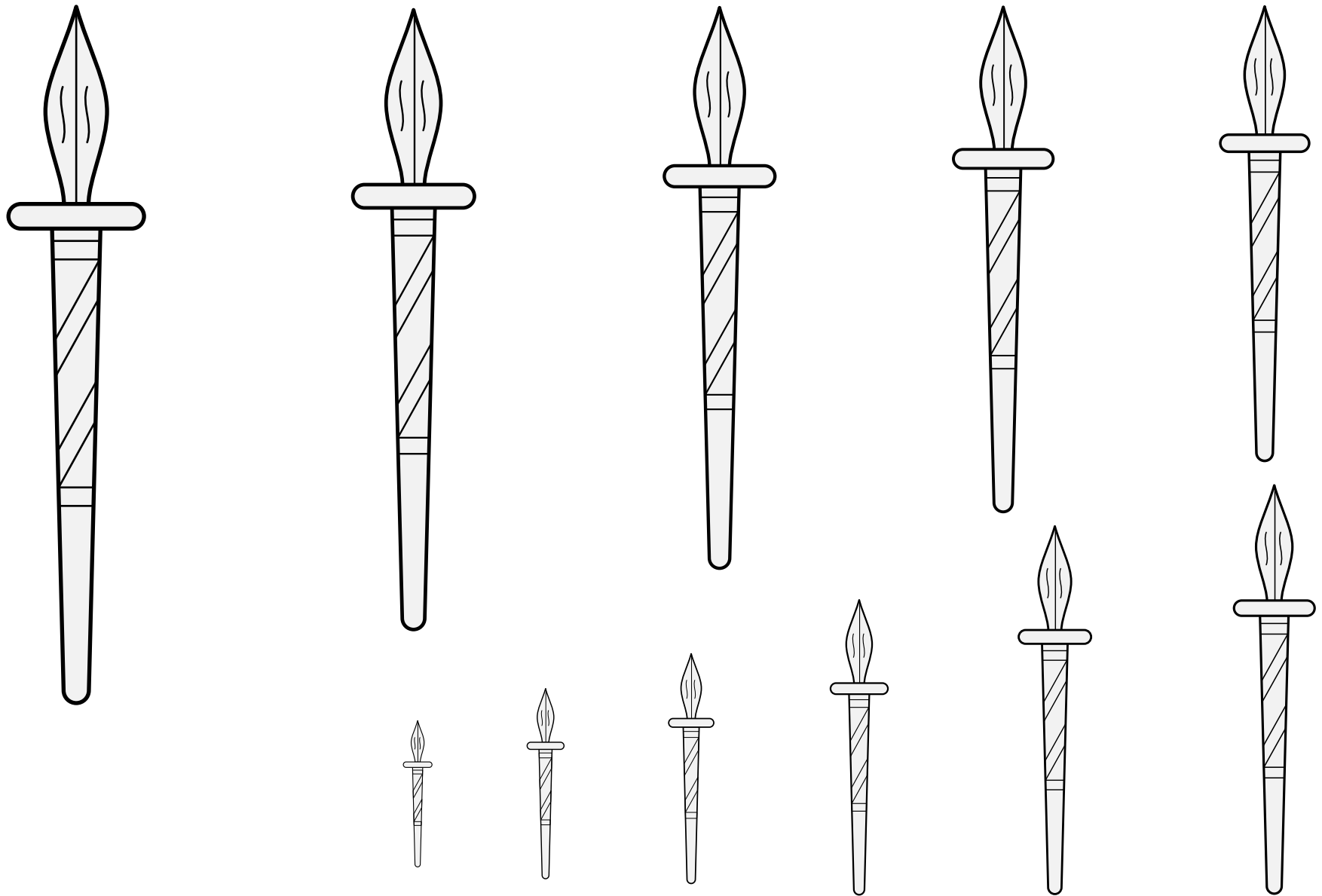

A weapon built from a wooden shaft with a small blade at the tip. A very long spear may be blazoned a pike.

Default orientation: point to chief. No proper coloration.

Source: Wappenbuch der Arlberg-Bruderschaft.

Artist: Vigil Raber. (Page 570.)

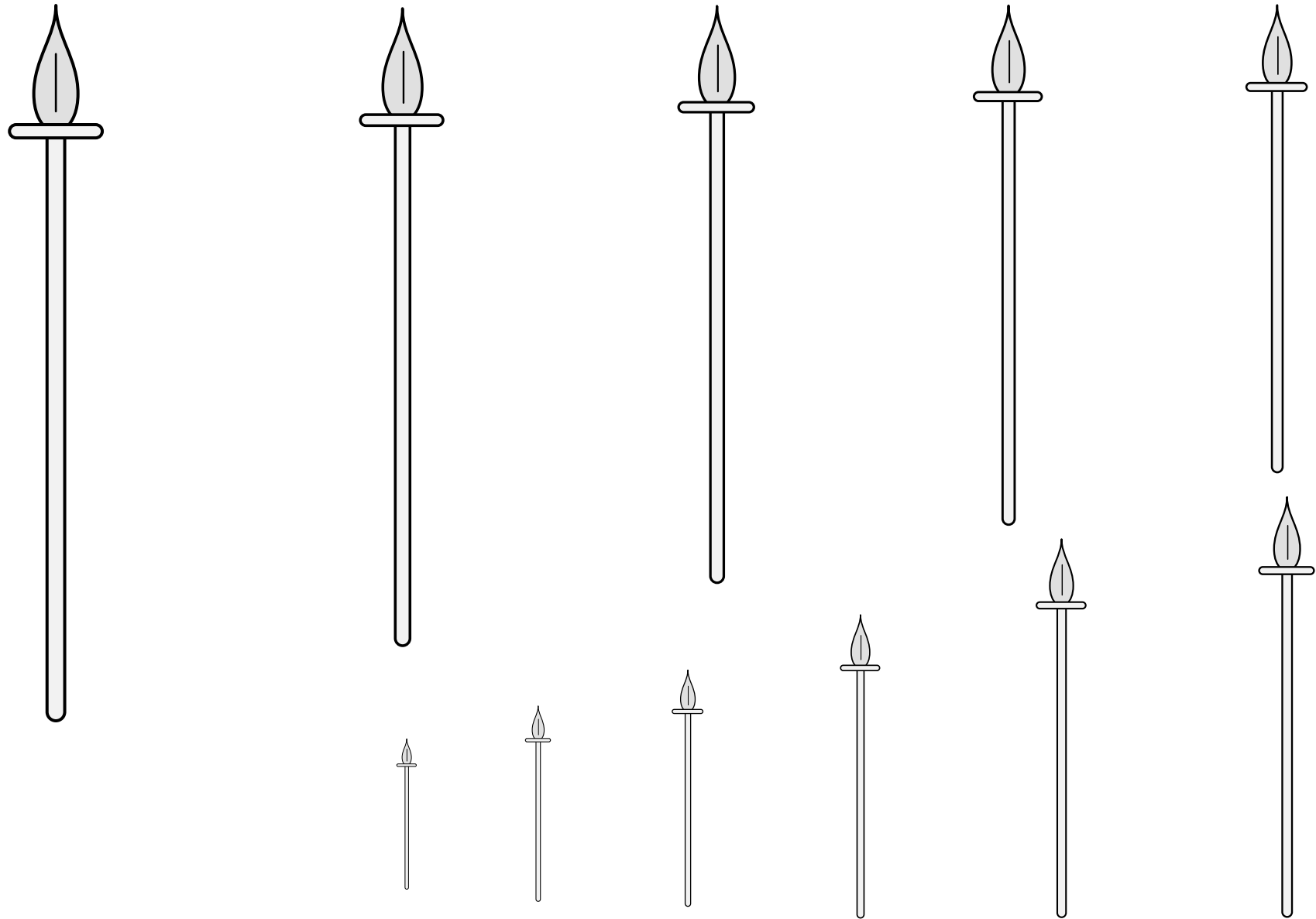

A weapon built from a wooden shaft with a small blade at the tip. A very long spear may be blazoned a pike.

Default orientation: point to chief. No proper coloration.

Source: Pennsic Heralds' Point Artists. Artist: Unknown.

**Spear (5)** 21.235

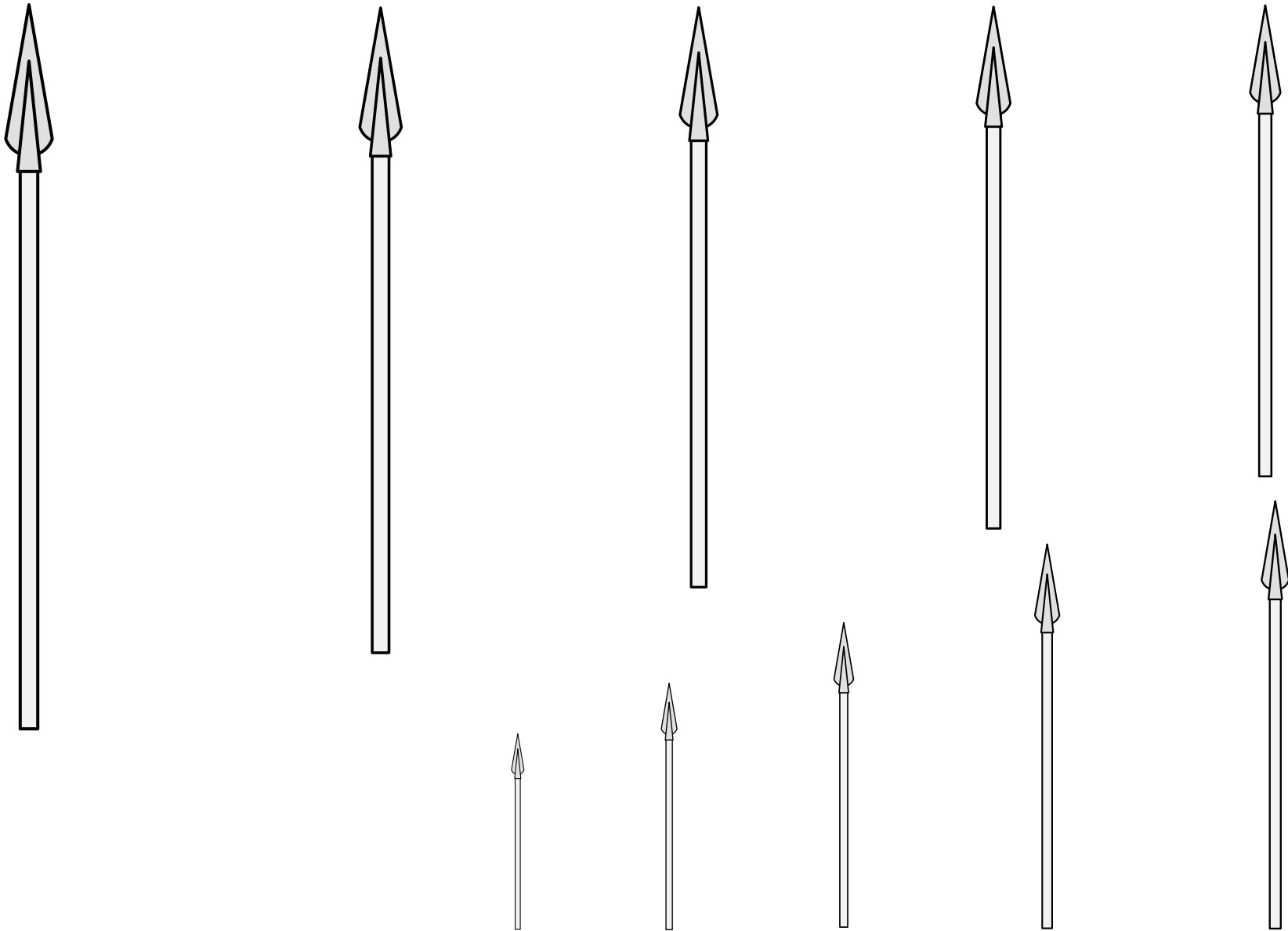

A weapon built from a wooden shaft with a small blade at the tip. A very long spear may be blazoned a pike.

Default orientation: point to chief. No proper coloration.

Source: Viking Answer Lady SVG Images For Heraldry. Artist: Gunnvôr silfrárr.



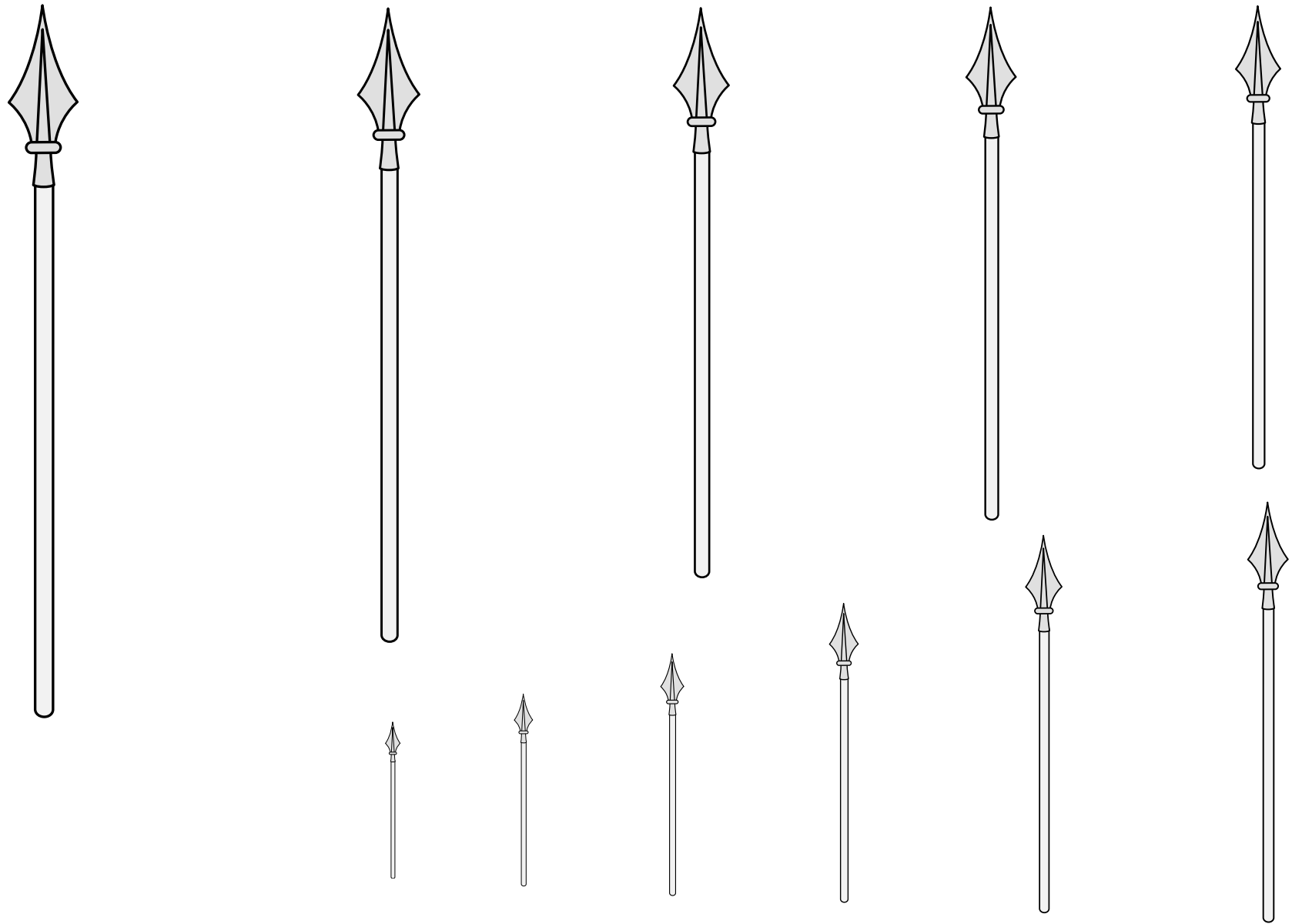

A weapon built from a wooden shaft with a small blade at the tip. A very long spear may be blazoned a pike.

Default orientation: point to chief. No proper coloration.

Source: WappenWiki. Artist: Joakim Spuller.

**Spear (7)** 21.237

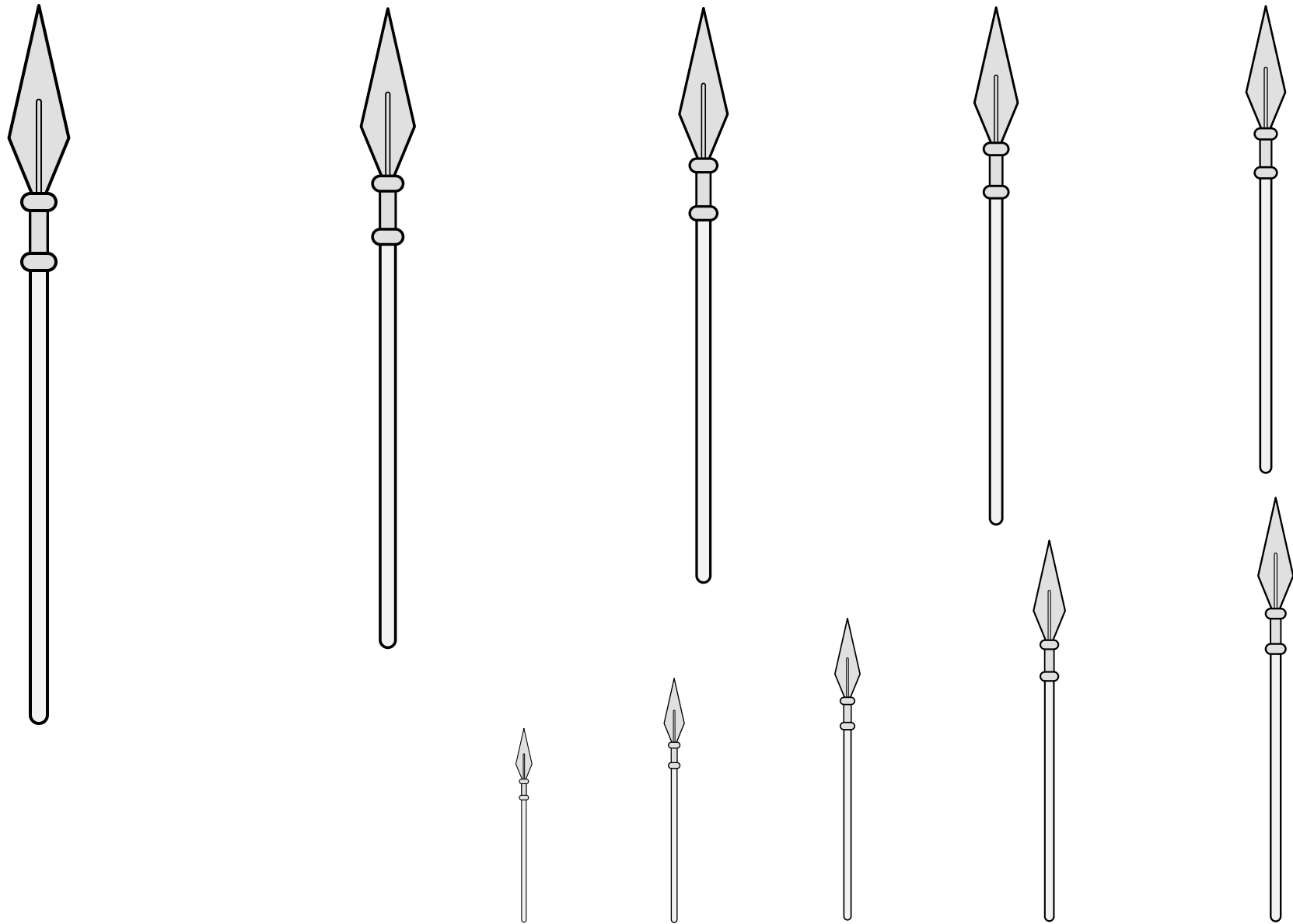

A weapon built from a wooden shaft with a small blade at the tip.  
A very long spear may be blazoned a pike.  
Default orientation: point to chief. No proper coloration.

**Spear (8)** 21.238

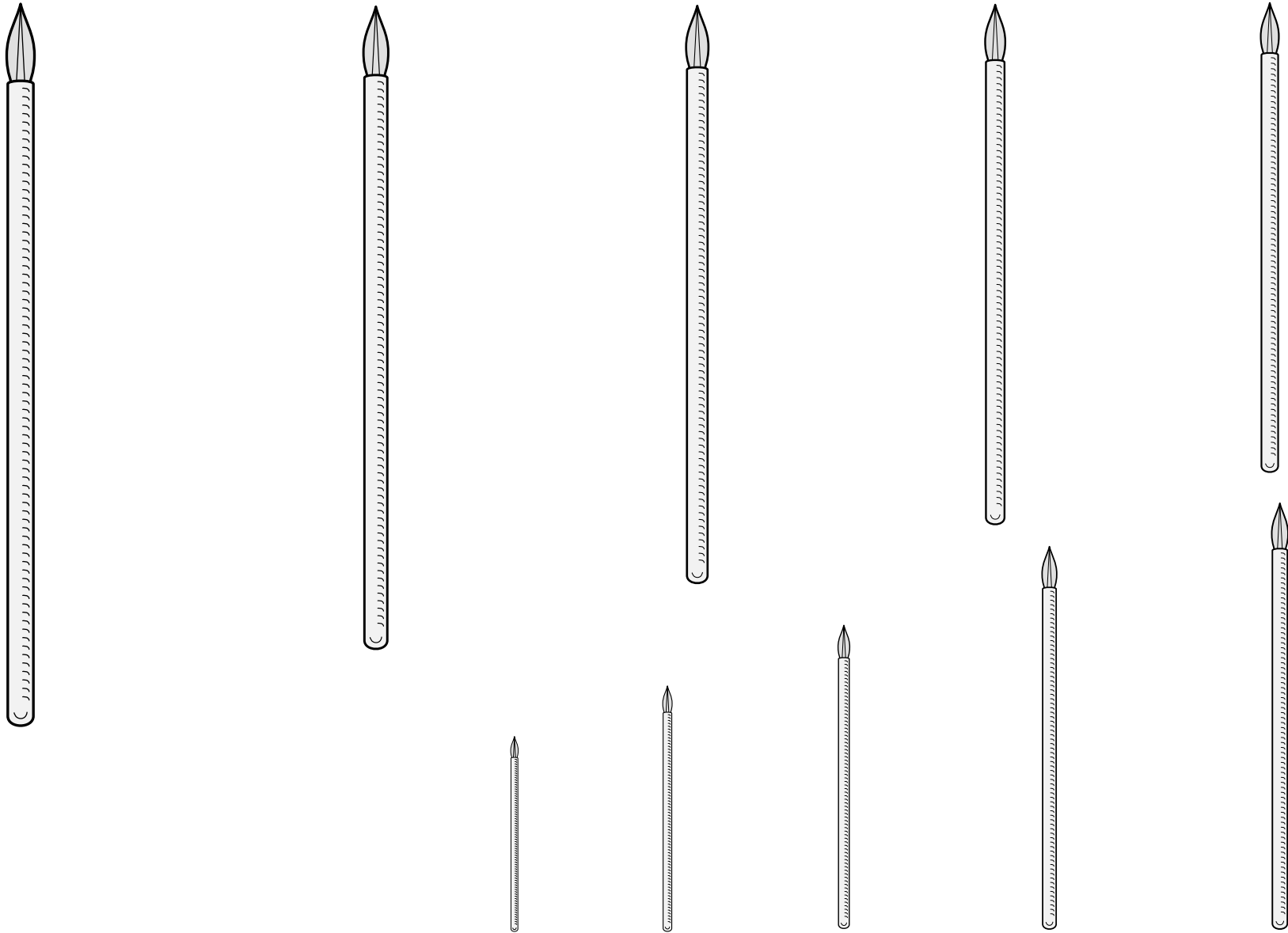

A weapon built from a wooden shaft with a small blade at the tip. A very long spear may be blazoned a pike.

Default orientation: point to chief. No proper coloration.

Source: Sammelband Mehrerer Wappenbücher. Artist unknown. (Folio 86v.)

Spear (9) 21.239

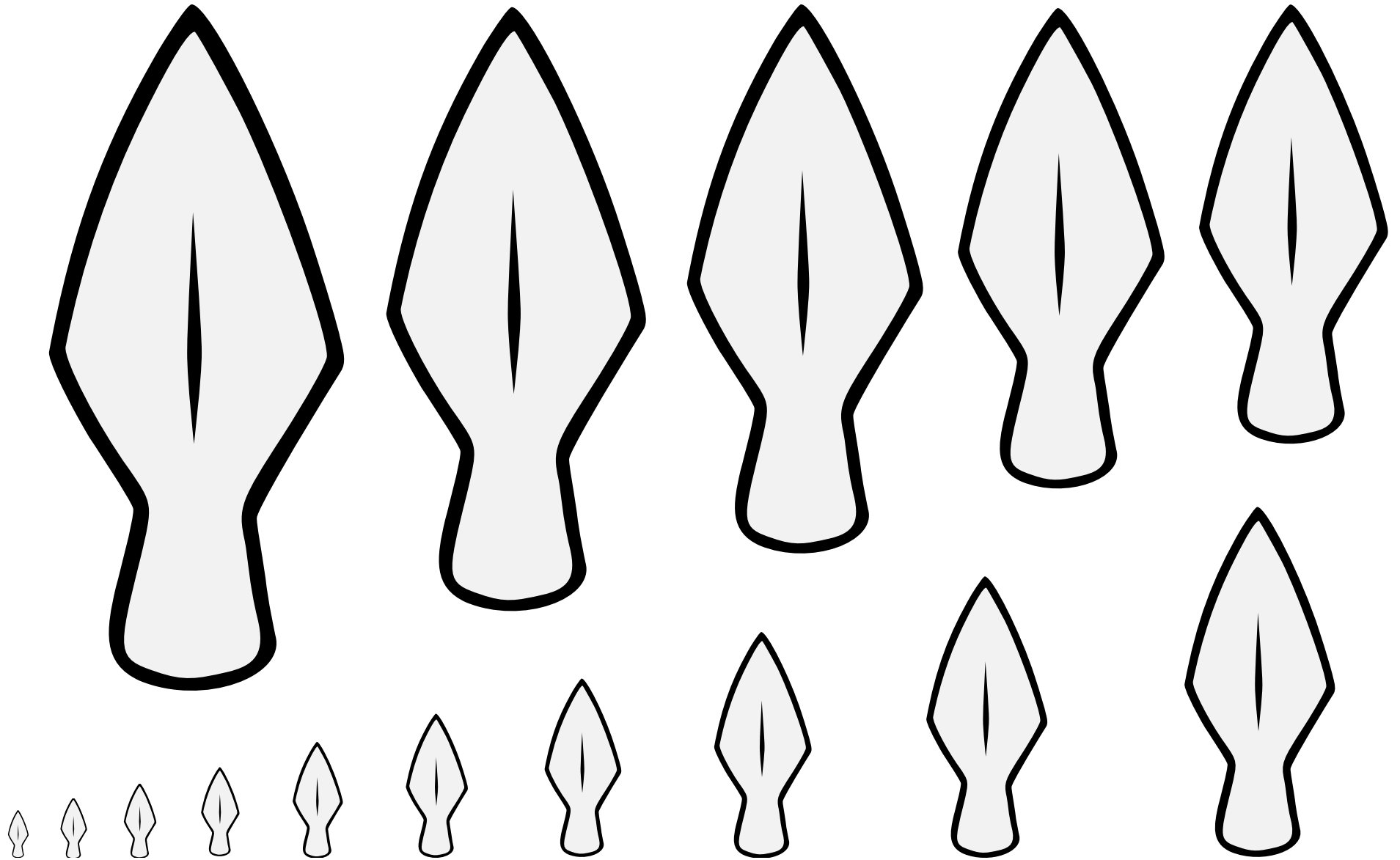

The pointy metal blade from the business end of a spear.  
Default orientation: point to chief. No proper coloration.  
Source: Pennsic Traceable Art. Artist unknown.

Spearhead (1) 21.240

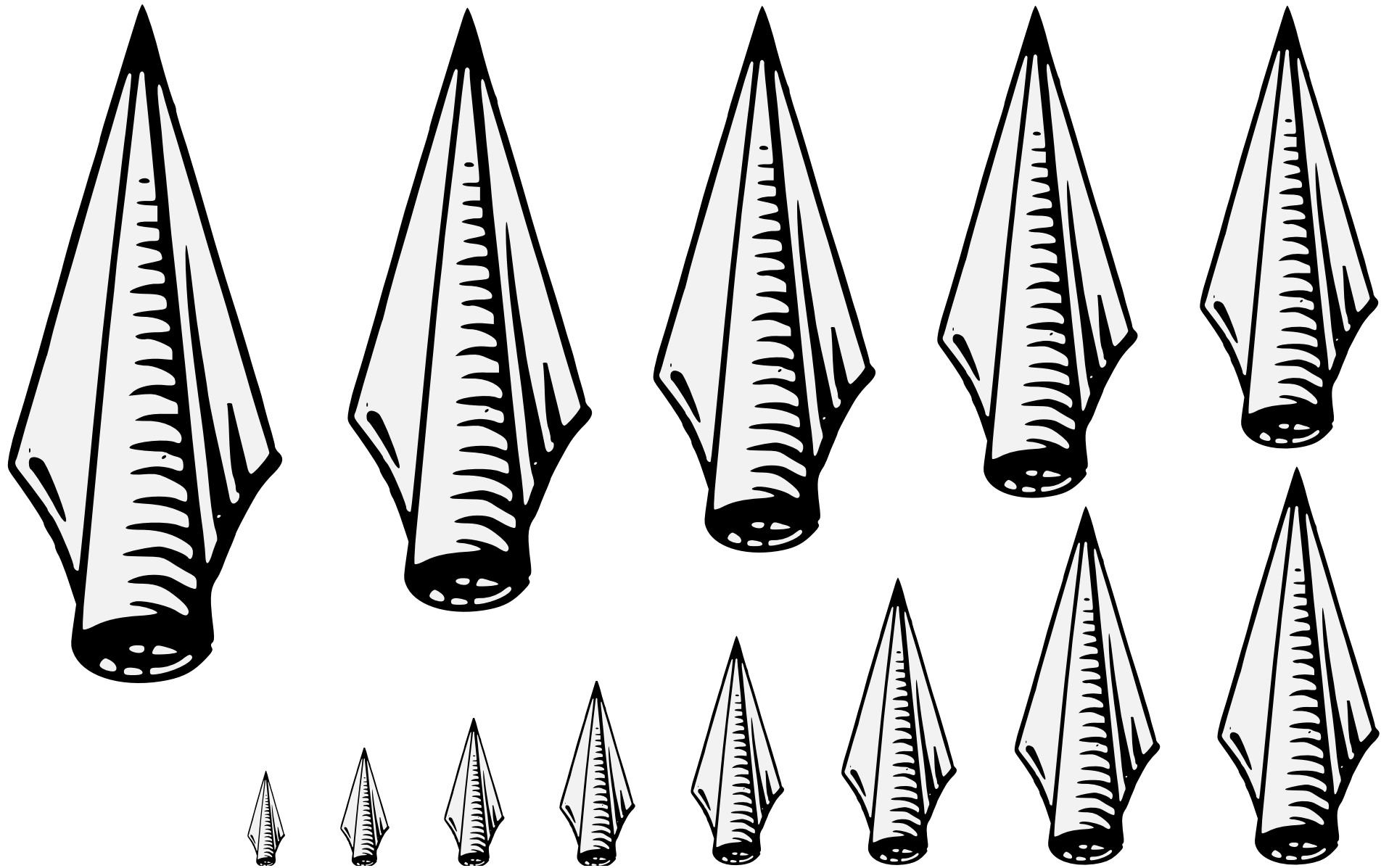

The pointy metal blade from the business end of a spear.  
Default orientation: point to chief. No proper coloration.  
Source: The Art of Heraldry. Artist: Unknown.

Spearhead (2) 21.241

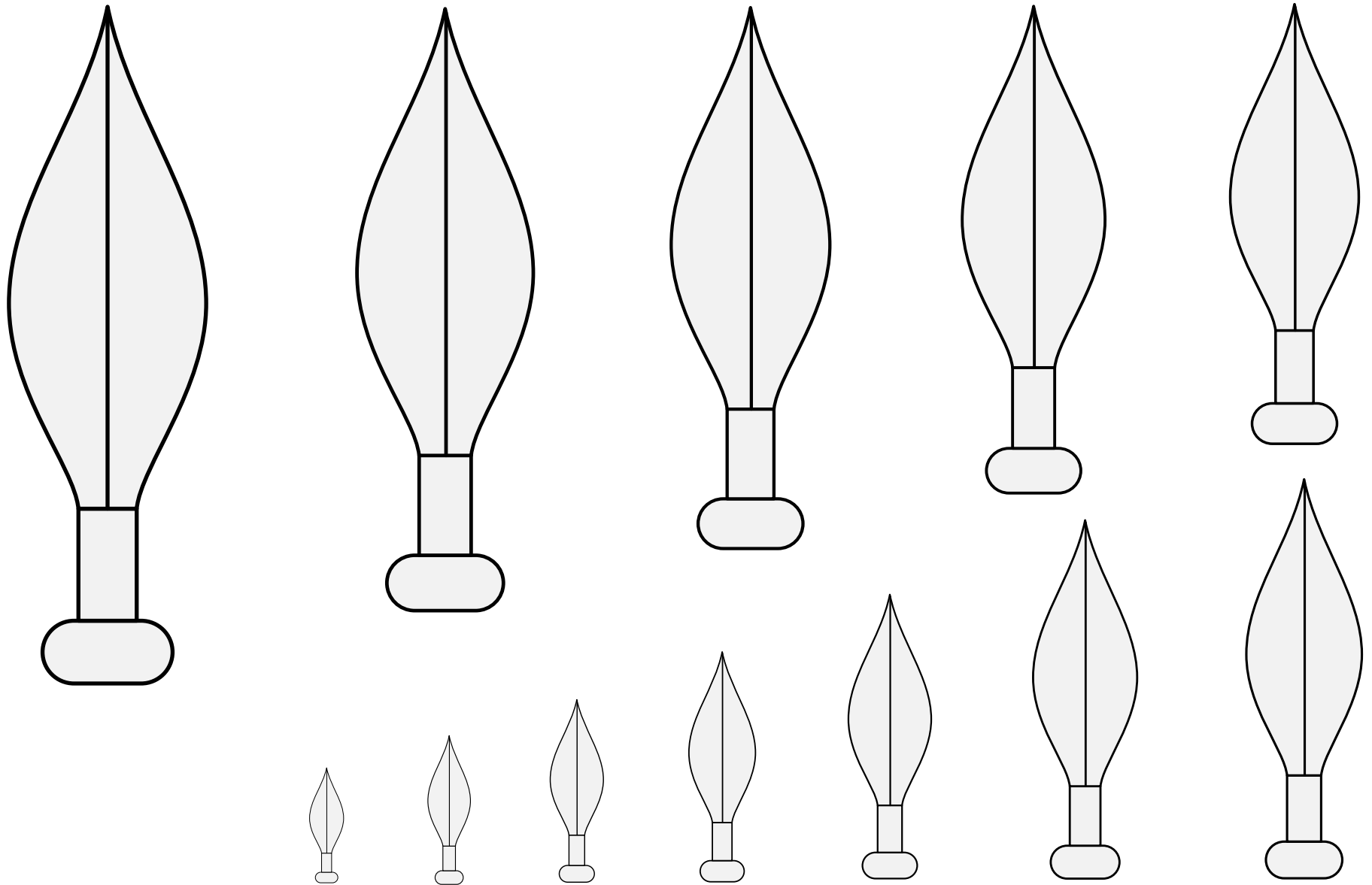

The pointy metal blade from the business end of a spear.  
Default orientation: point to chief. No proper coloration.  
Source: English Arms A. Artist unknown. (Page 151.)

**Spearhead (3)** 21.242

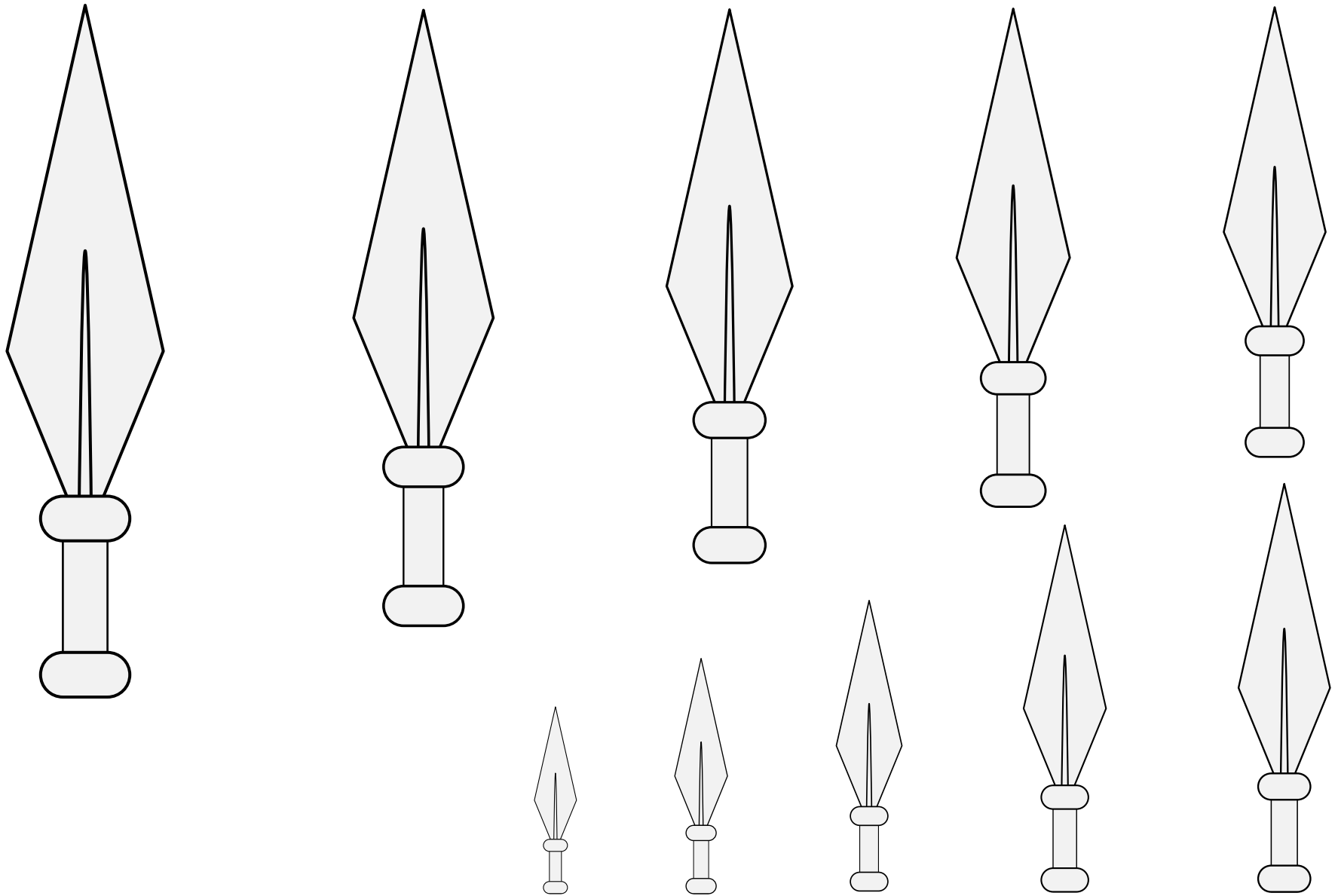

The pointy metal blade from the business end of a spear.  
Default orientation: point to chief. No proper coloration.

**Spearhead (4)** 21.243

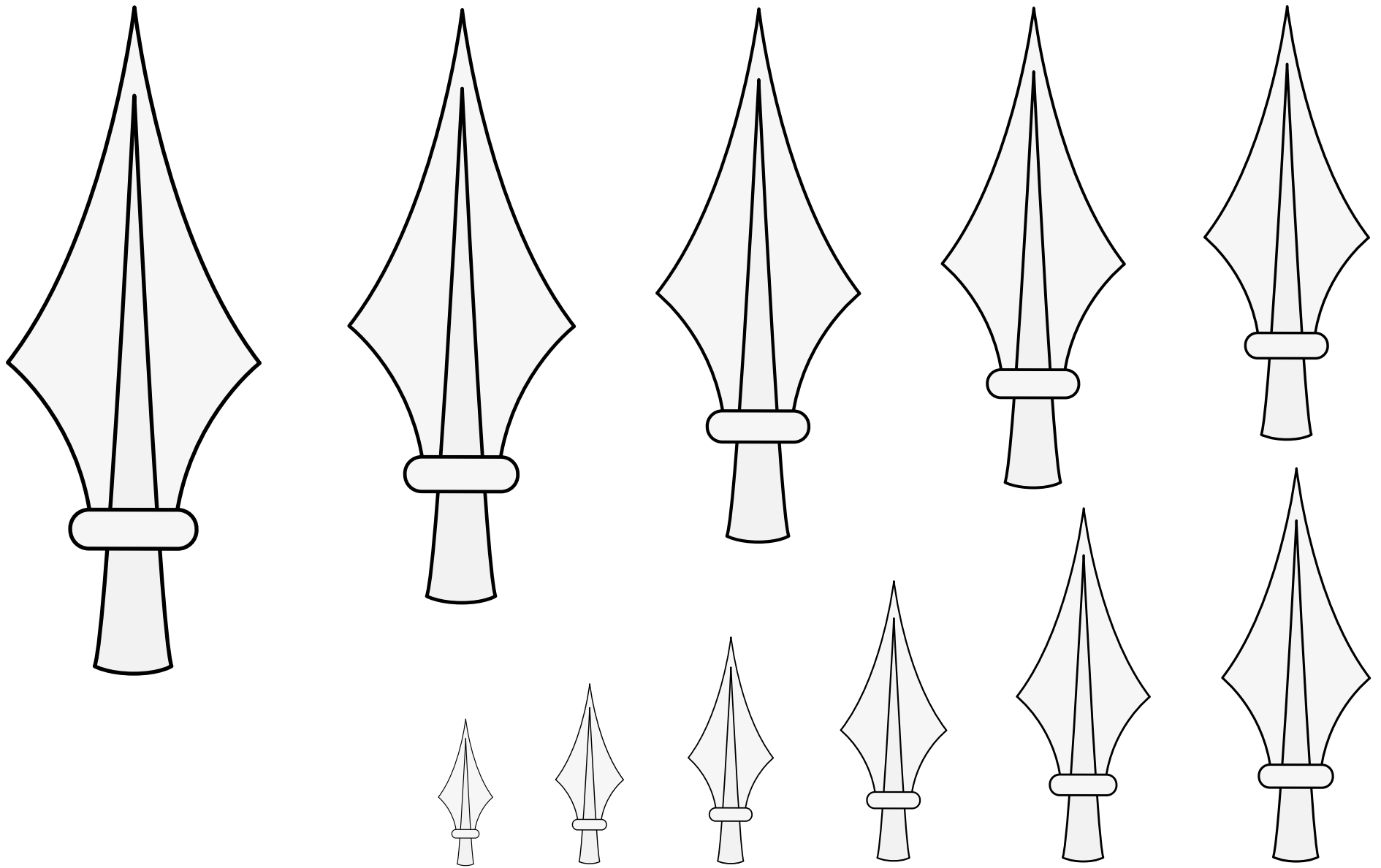

The pointy metal blade from the business end of a spear.  
Default orientation: point to chief. No proper coloration.  
Source: WappenWiki. Artist: Joakim Spuller.

**Spearhead (5)** 21.244



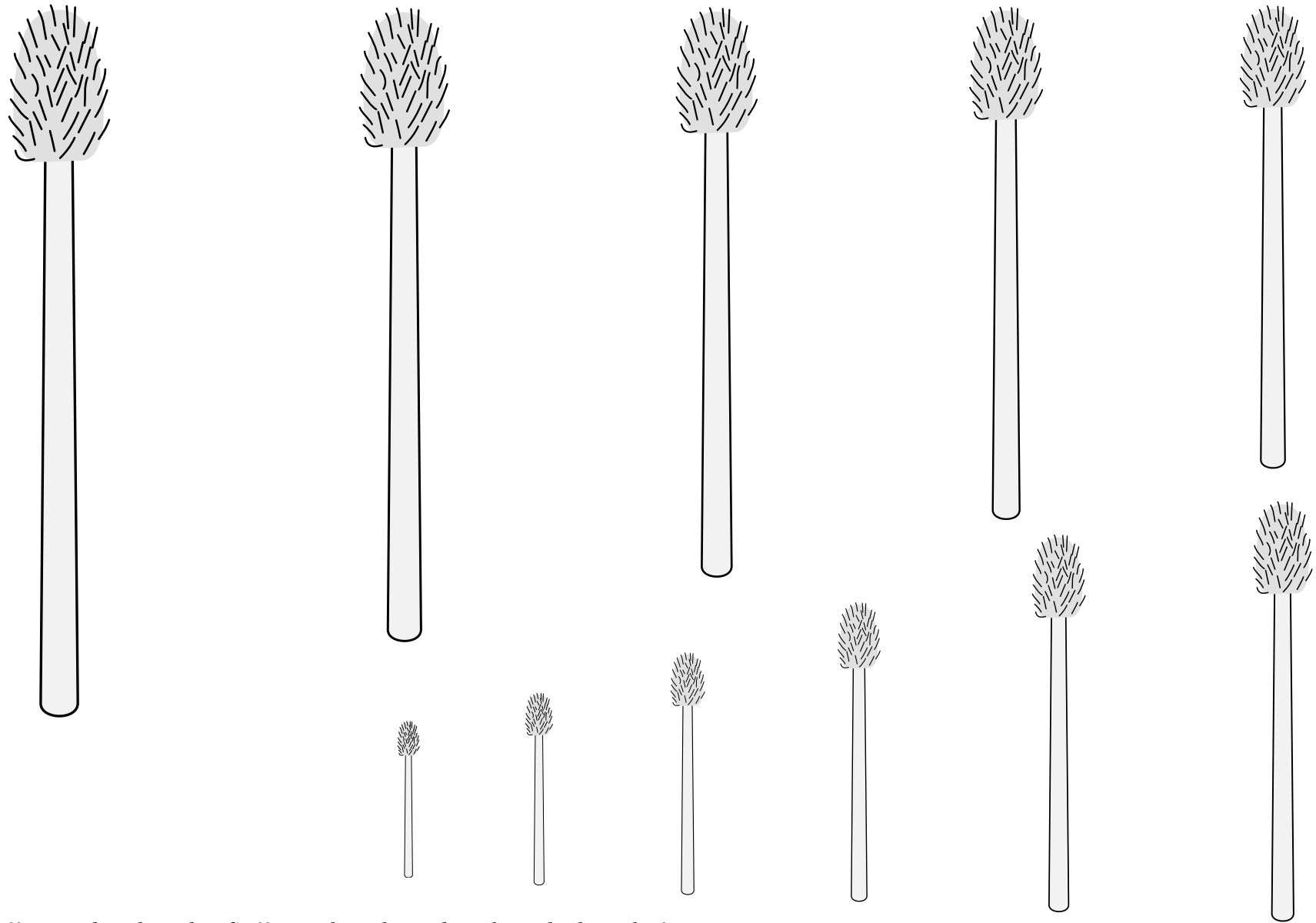

A long staff capped with with a fluffy wool swab used to clean the barrel of a cannon.

Default orientation: sponge to chief. No proper coloration.

Source: A Display of Heraldry. Artist: John Guillim.  
(Manuscript folio 95r.) Adapted by Iago ab Adam.

**Sponge, Artillery** 21.245

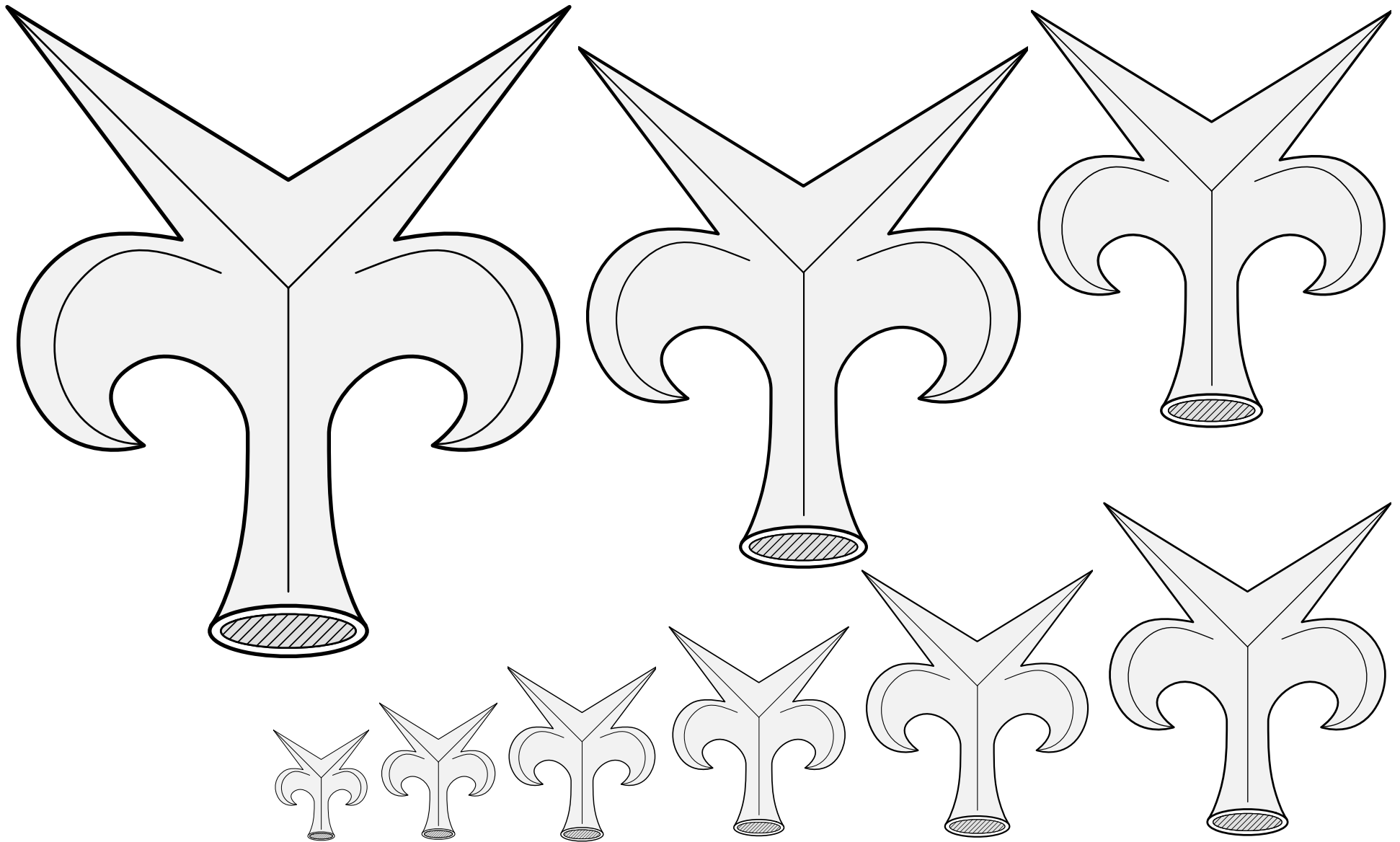

The blade from a specialized pole arm, blazoned with the German word for “war fork blade.”

Default orientation: points to chief. No proper coloration.

Source: Neustifter Wappenbuch. Artist: Vigil Raber.  
(From the arms of Lynnser.)

**Streitgabelklinge** • 21.246

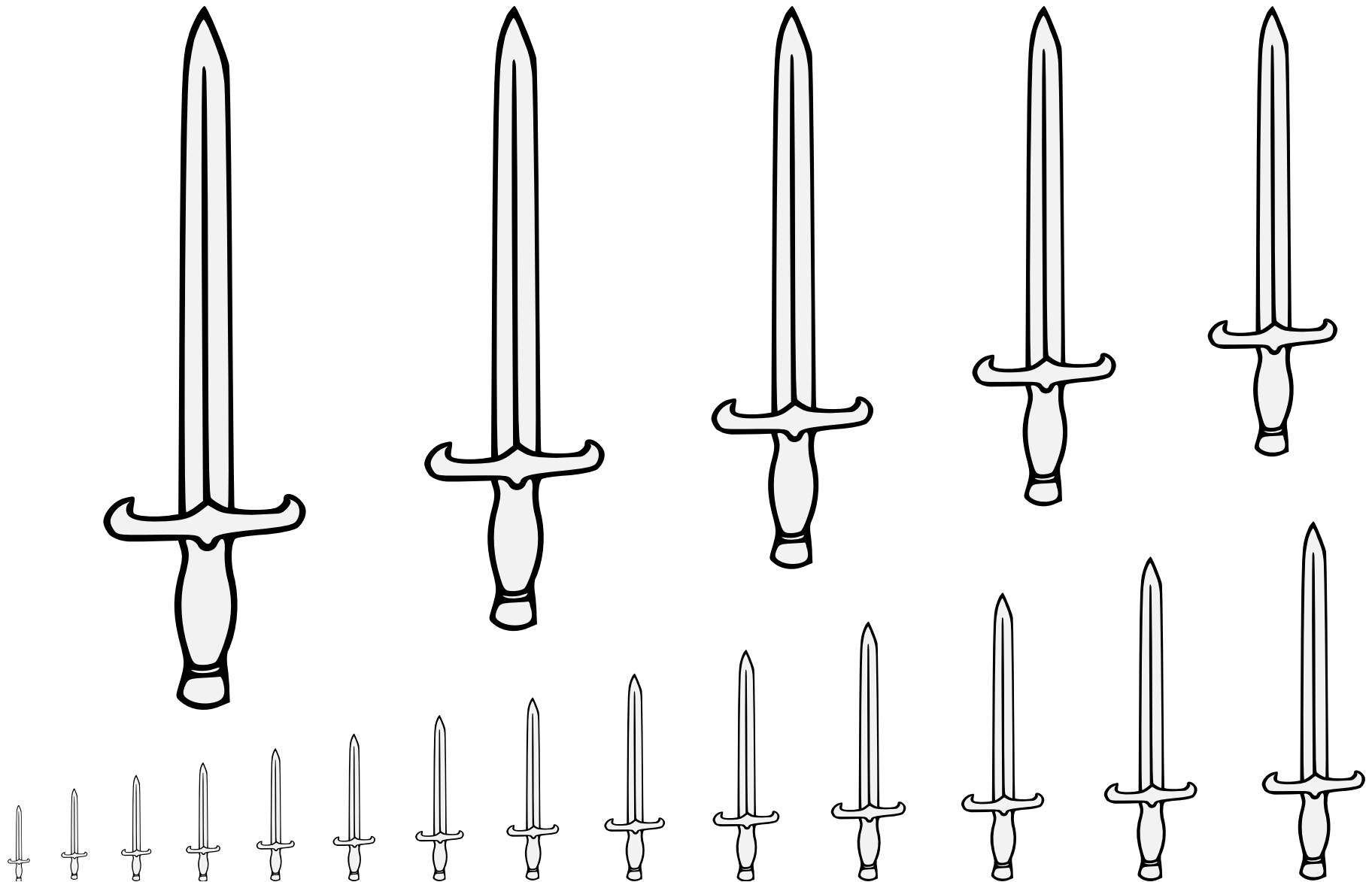

A metal tool for making holes in people.

Default orientation: point to chief. Proper coloration: blade argent, hilt Or.

Source: Pennsic Traceable Art. Artist: Roana d'Evreux (attributed).

Sword (1) 21.247

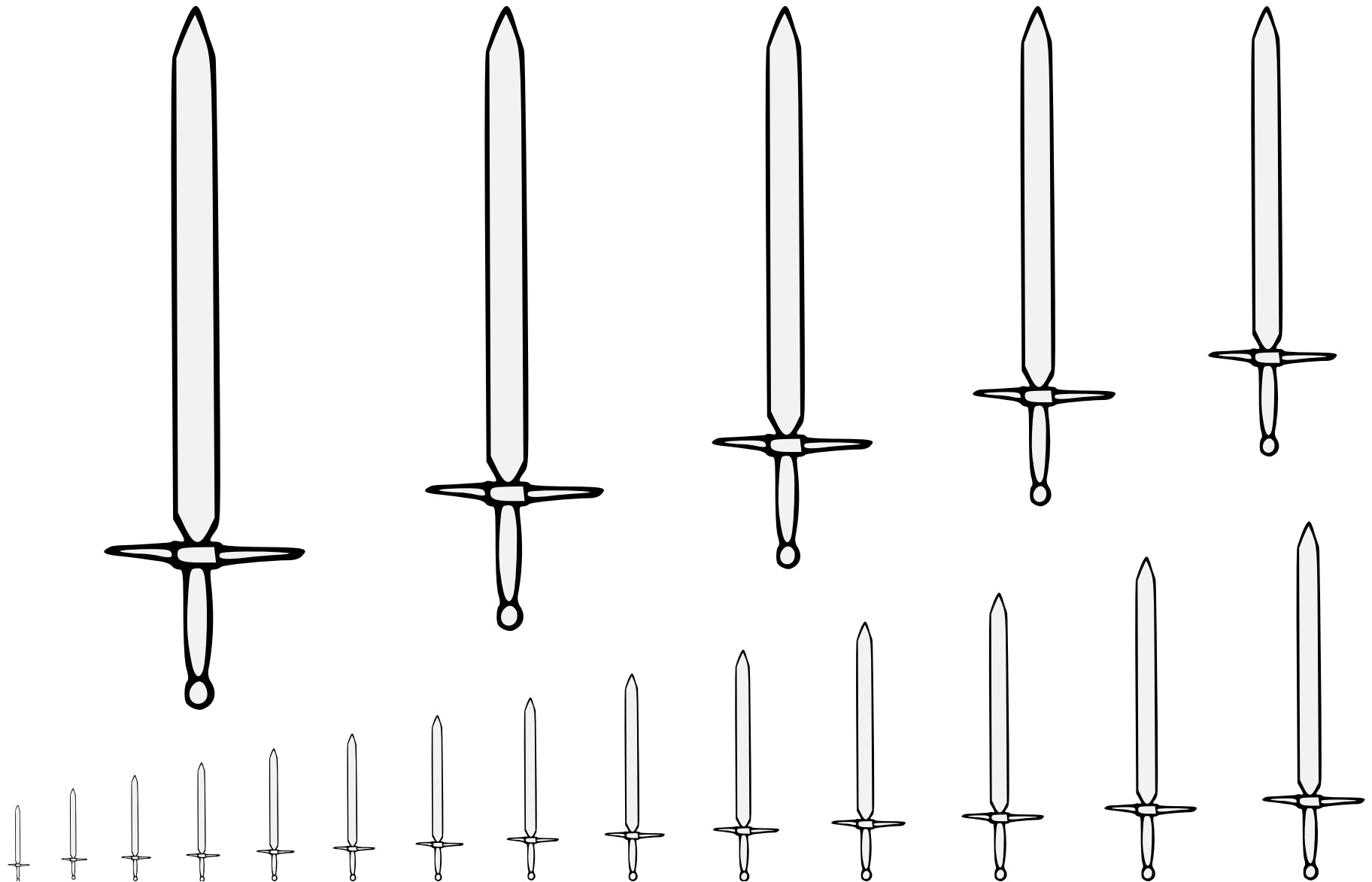

A metal tool for making holes in people.

Default orientation: point to chief. Proper coloration: blade argent, hilt Or.

Source: Pennsic Traceable Art. Artist unknown.

Sword (2) 21.248

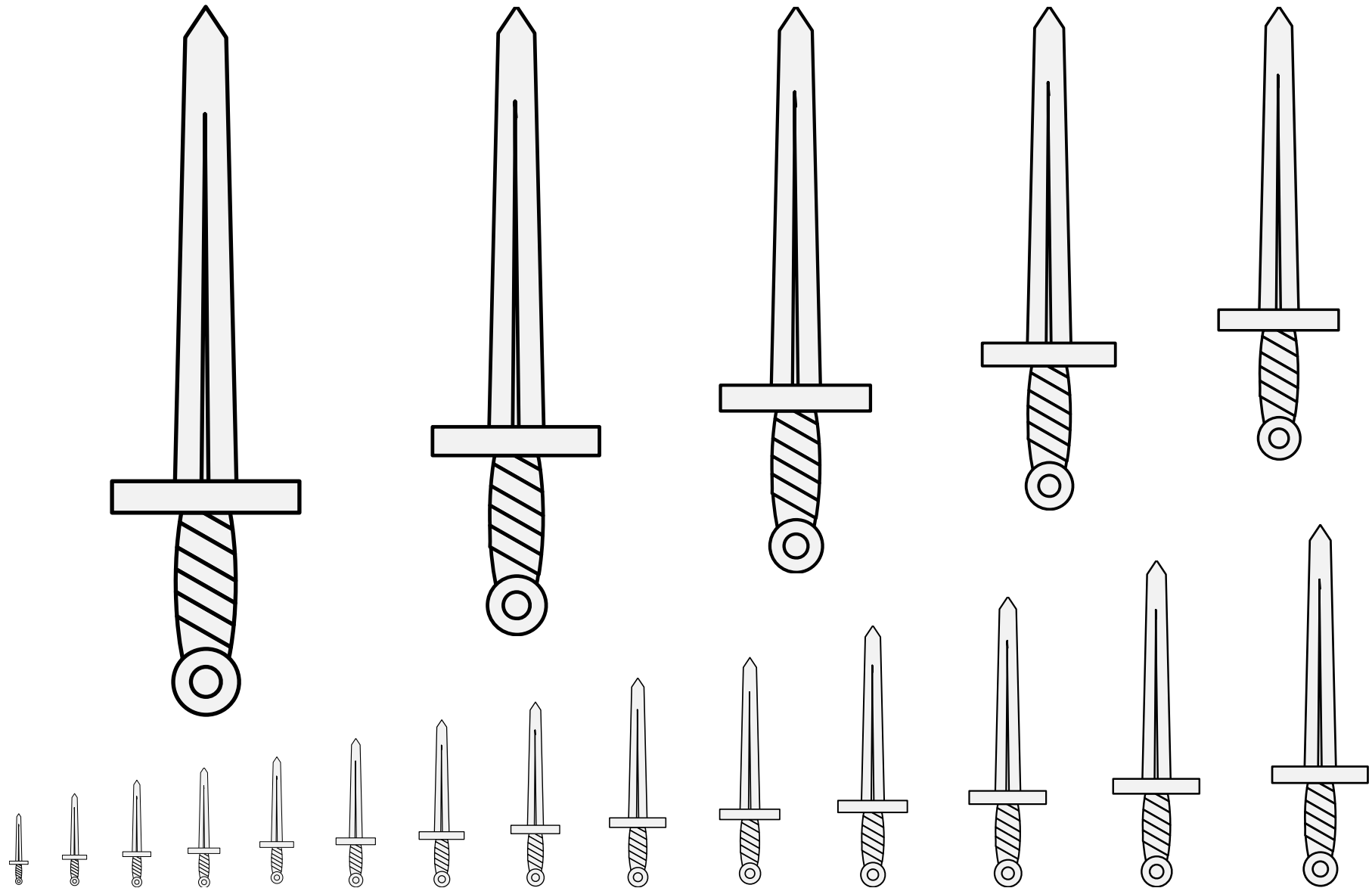

A metal tool for making holes in people.

Default orientation: point to chief. Proper coloration: blade argent, hilt Or.

Source: Viking Answer Lady SVG Images For Heraldists. Artist: Gunnvôr silfráhr.

Sword (3) 21.249

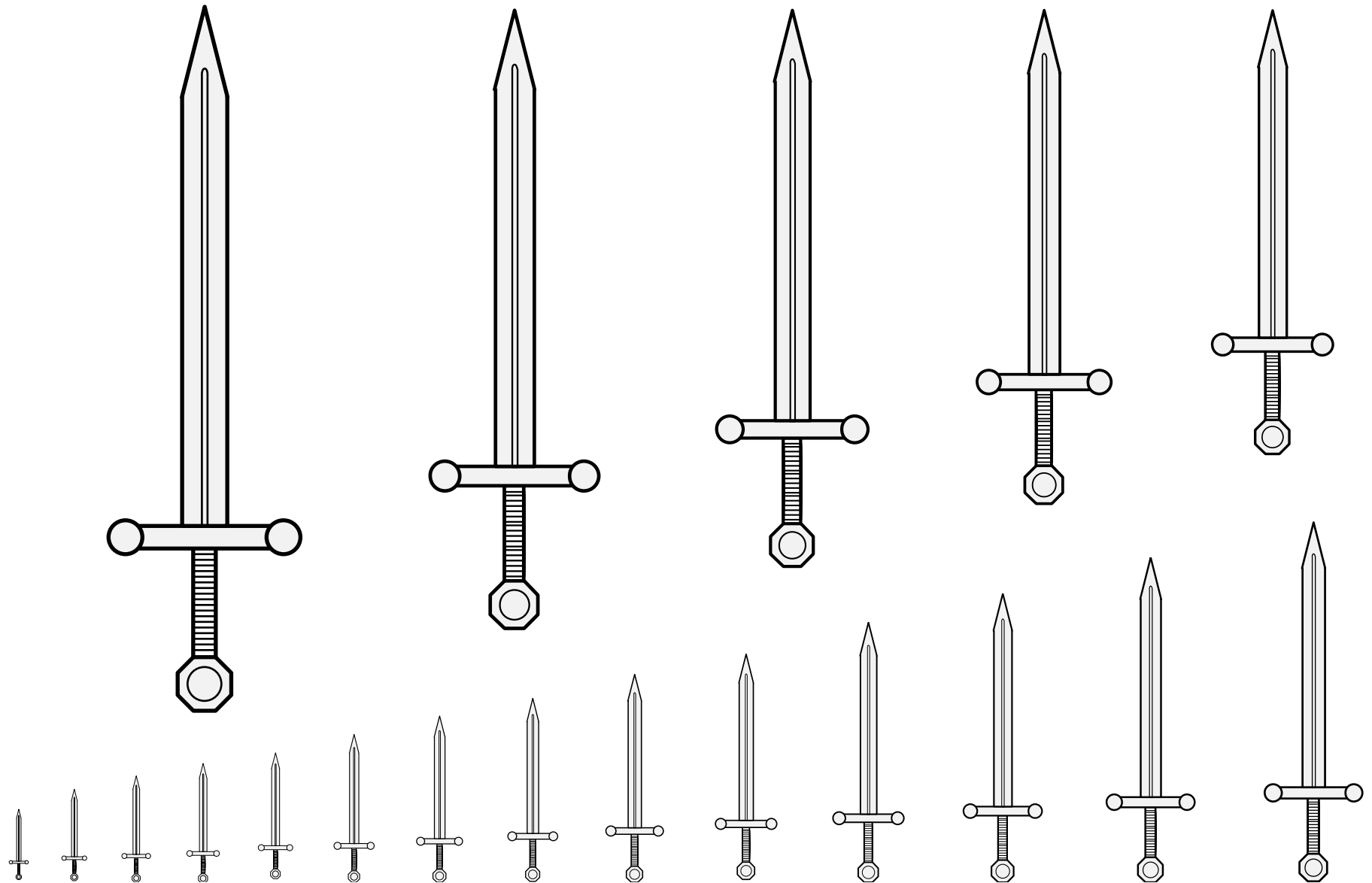

A metal tool for making holes in people.

Default orientation: point to chief. Proper coloration: blade argent, hilt Or.

Source: Viking Answer Lady SVG Images For Heraldists. Artist: Gunnvôr silfráhr.

Sword (4) 21.250

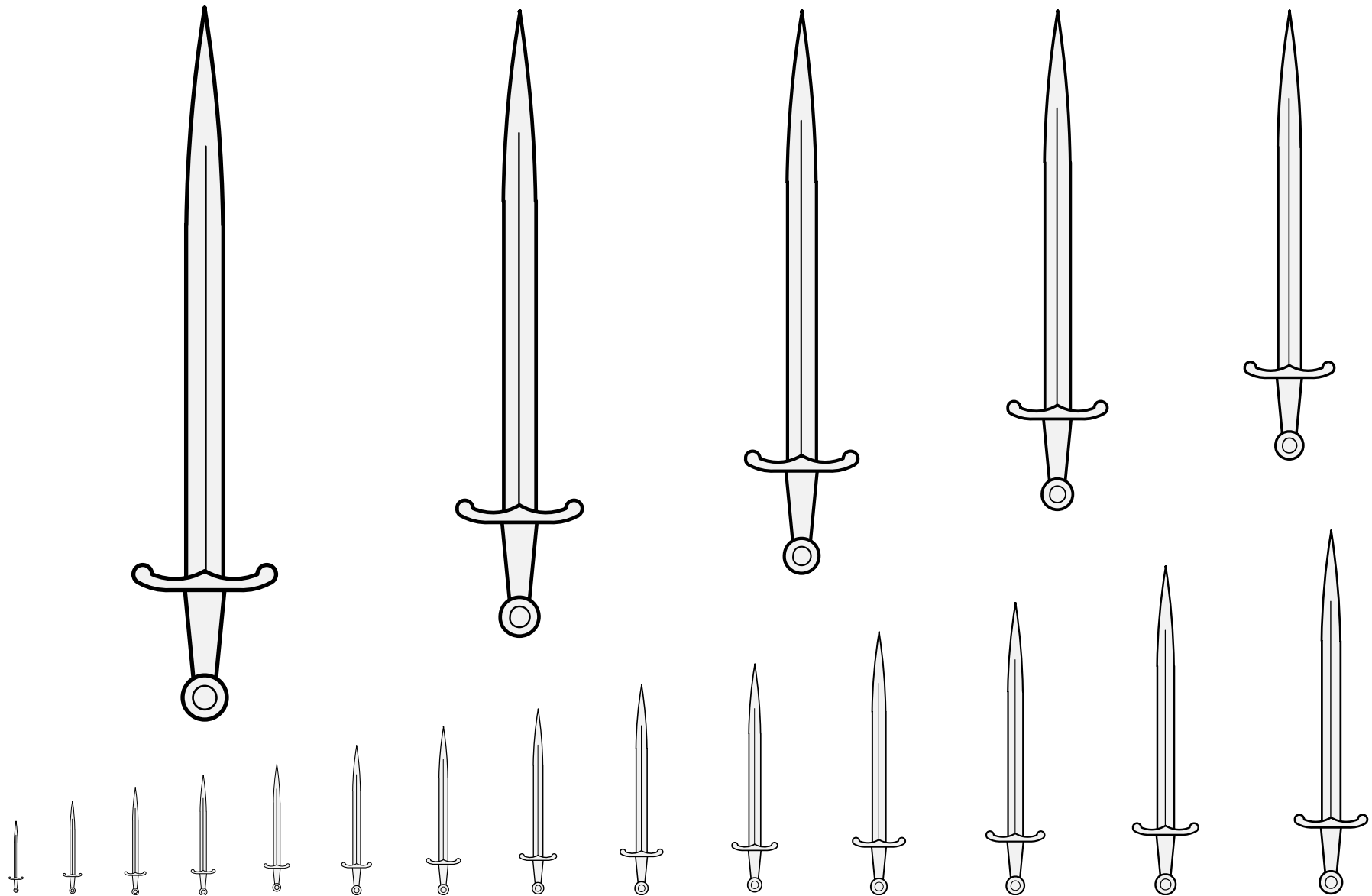

A metal tool for making holes in people.

Default orientation: point to chief. Proper coloration: blade argent, hilt Or.

Source: Viking Answer Lady SVG Images For Heraldists. Artist: Gunnvôr silfráhr.

**Sword (5)** 21.251

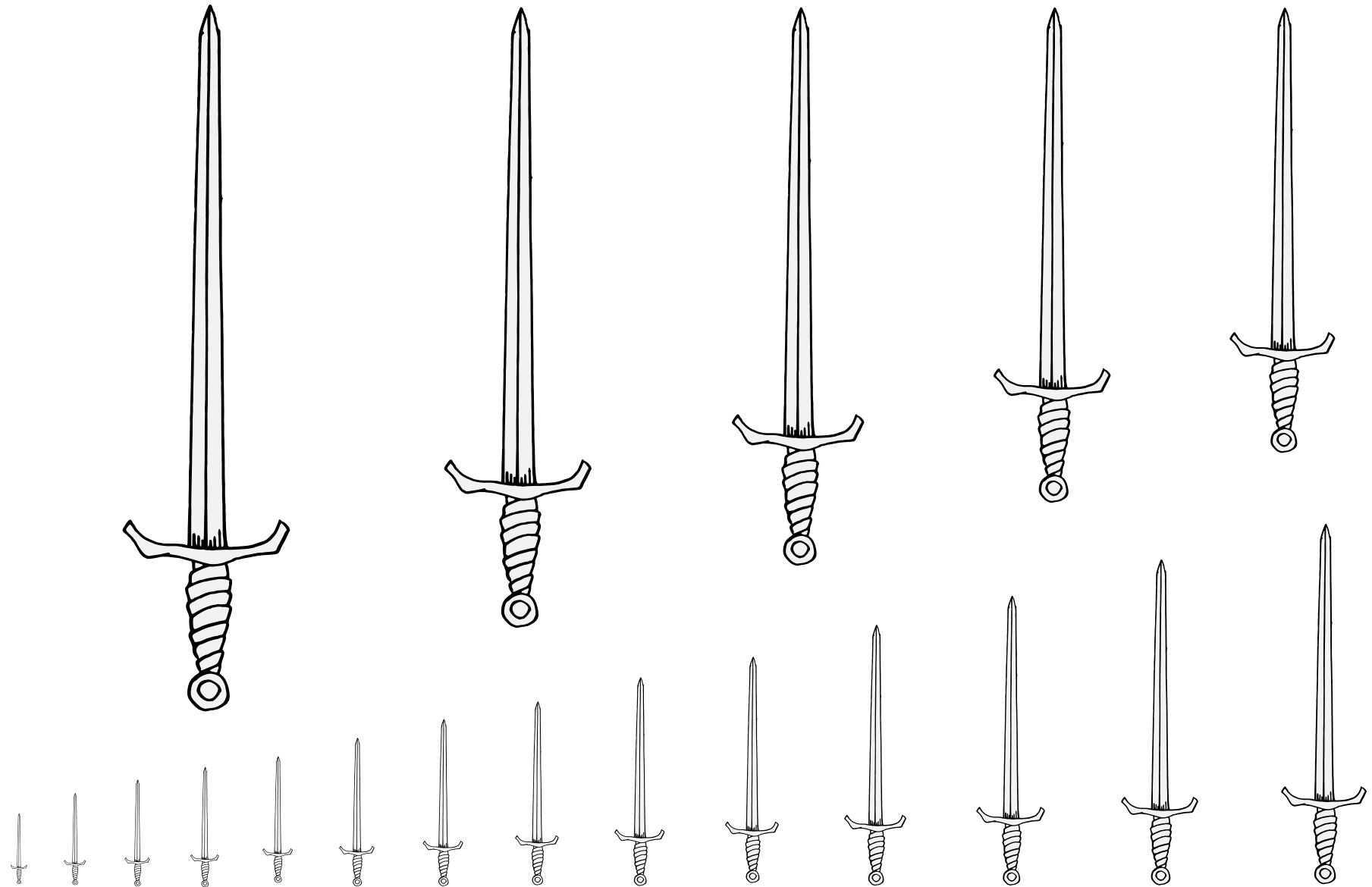

A metal tool for making holes in people.

Default orientation: point to chief. Proper coloration: blade argent, hilt Or.

Source: Heraldic Templates. Artist: Torric inn Björn.

Sword (6) 21.252



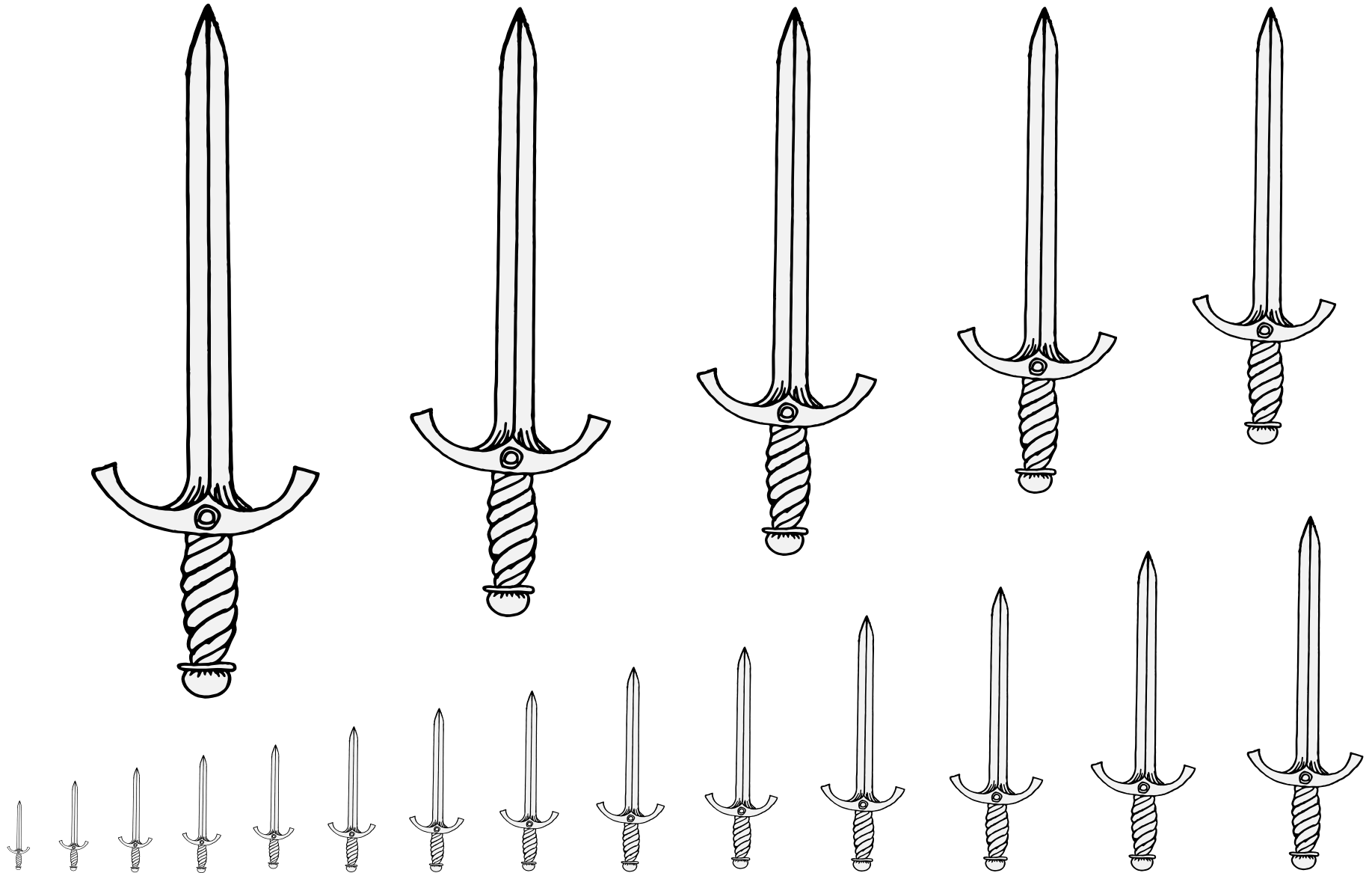

A metal tool for making holes in people.

Default orientation: point to chief. Proper coloration: blade argent, hilt Or.

Source: Heraldic Templates. Artist: Torric inn Björn.

Sword (7) 21.253

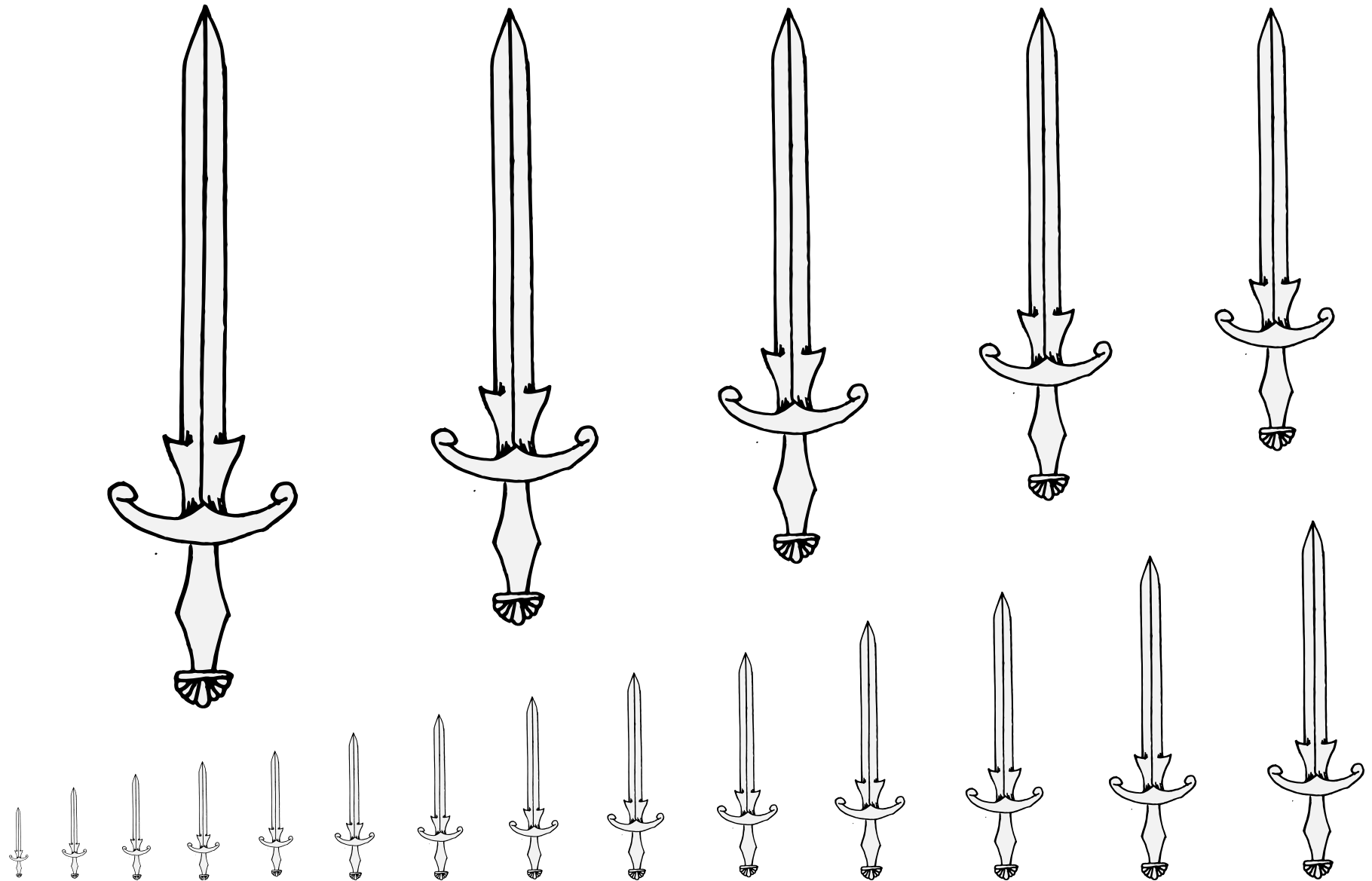

A metal tool for making holes in people.

Default orientation: point to chief. Proper coloration: blade argent, hilt Or.

Source: Heraldic Templates. Artist: Torric inn Björn.

Sword (8) 21.254

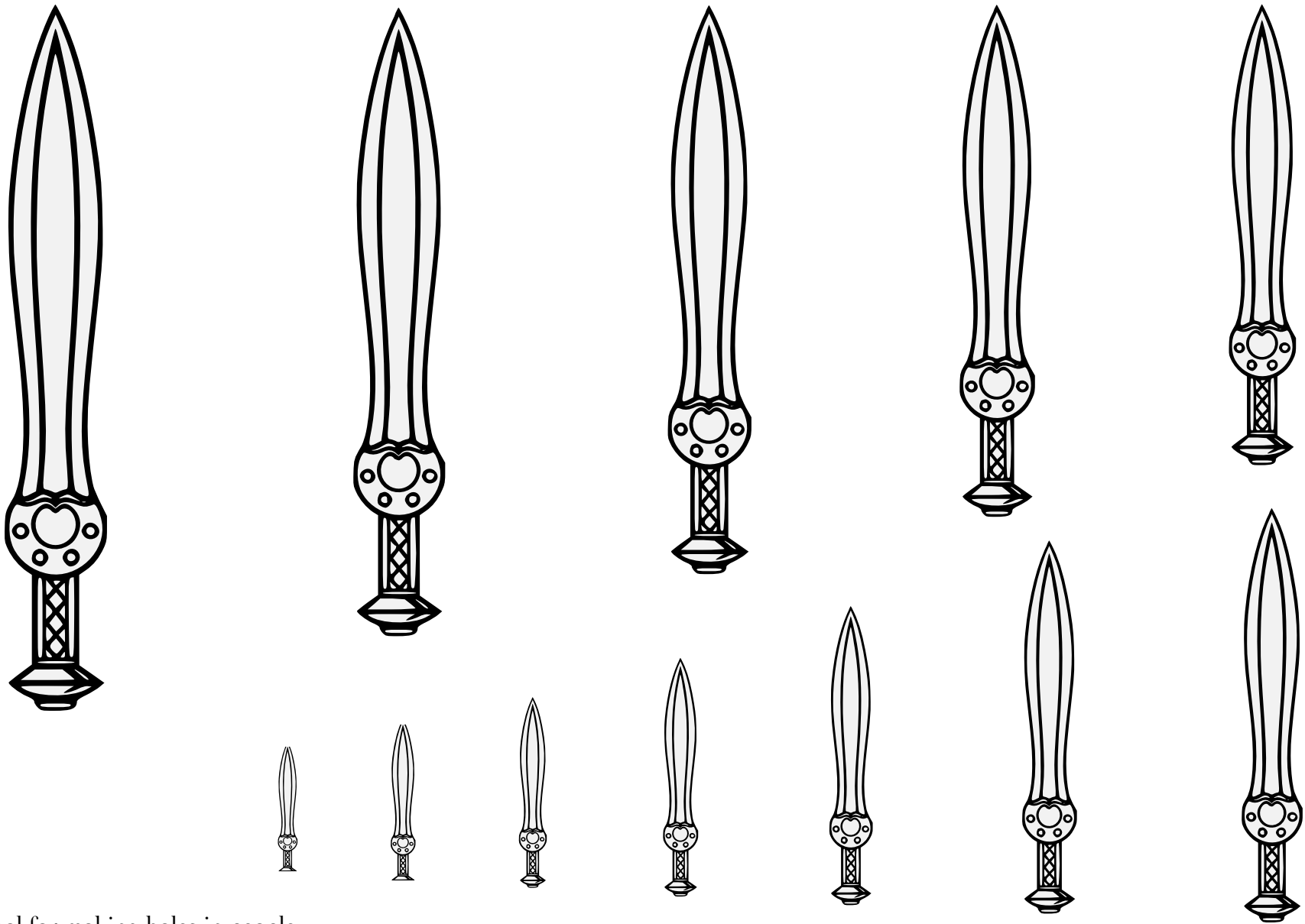

A metal tool for making holes in people.

Default orientation: point to chief. Proper coloration: blade argent, hilt Or.

Source: Wappen und Siegel des Kreises Alfeld.

Artist: Gustav Völker.

Sword (9) 21.255

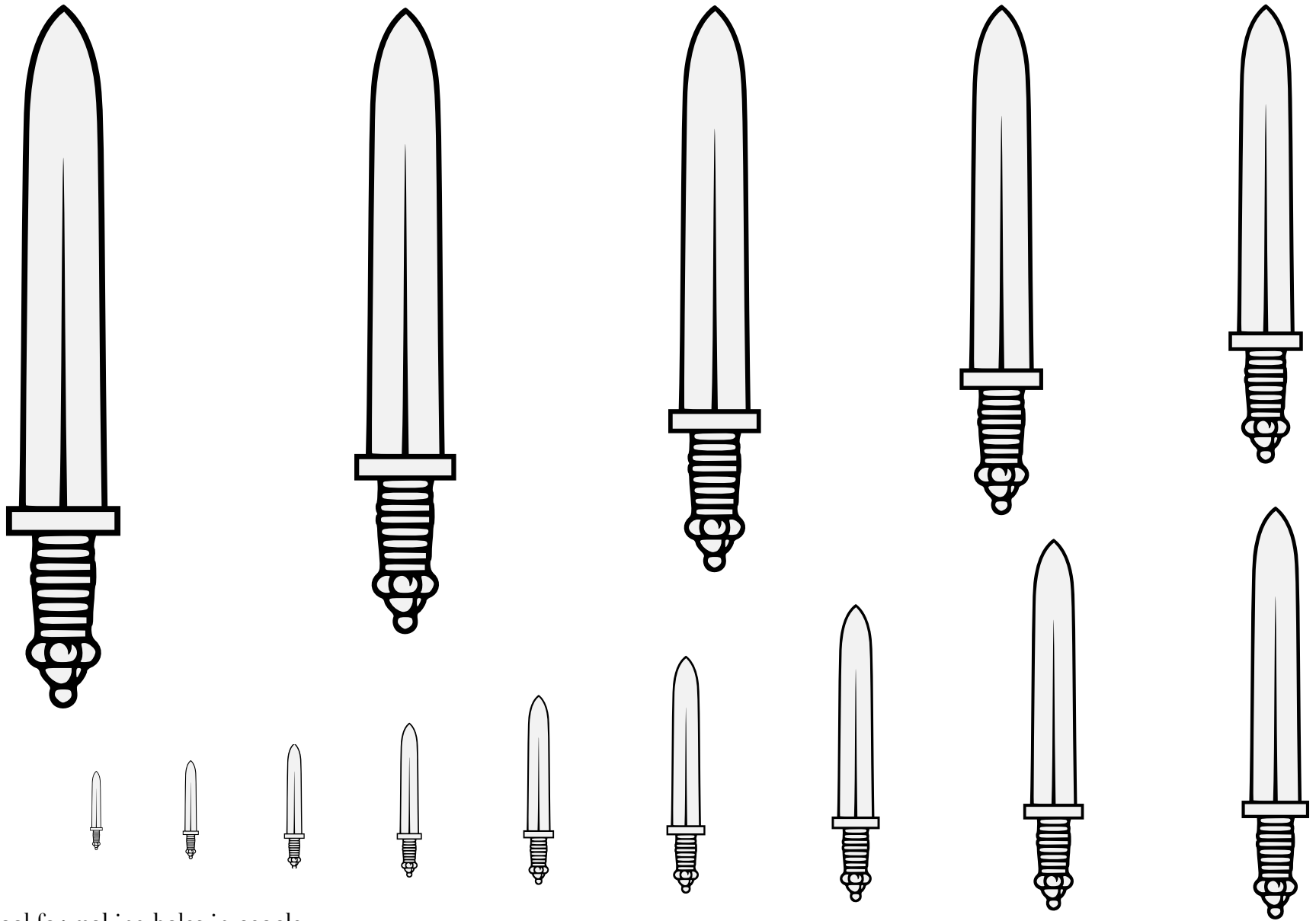

A metal tool for making holes in people.

Default orientation: point to chief. Proper coloration: blade argent, hilt Or.

Source: Wappen und Siegel des Kreises Alfeld.

Artist: Gustav Völker.

Sword (10) 21.256

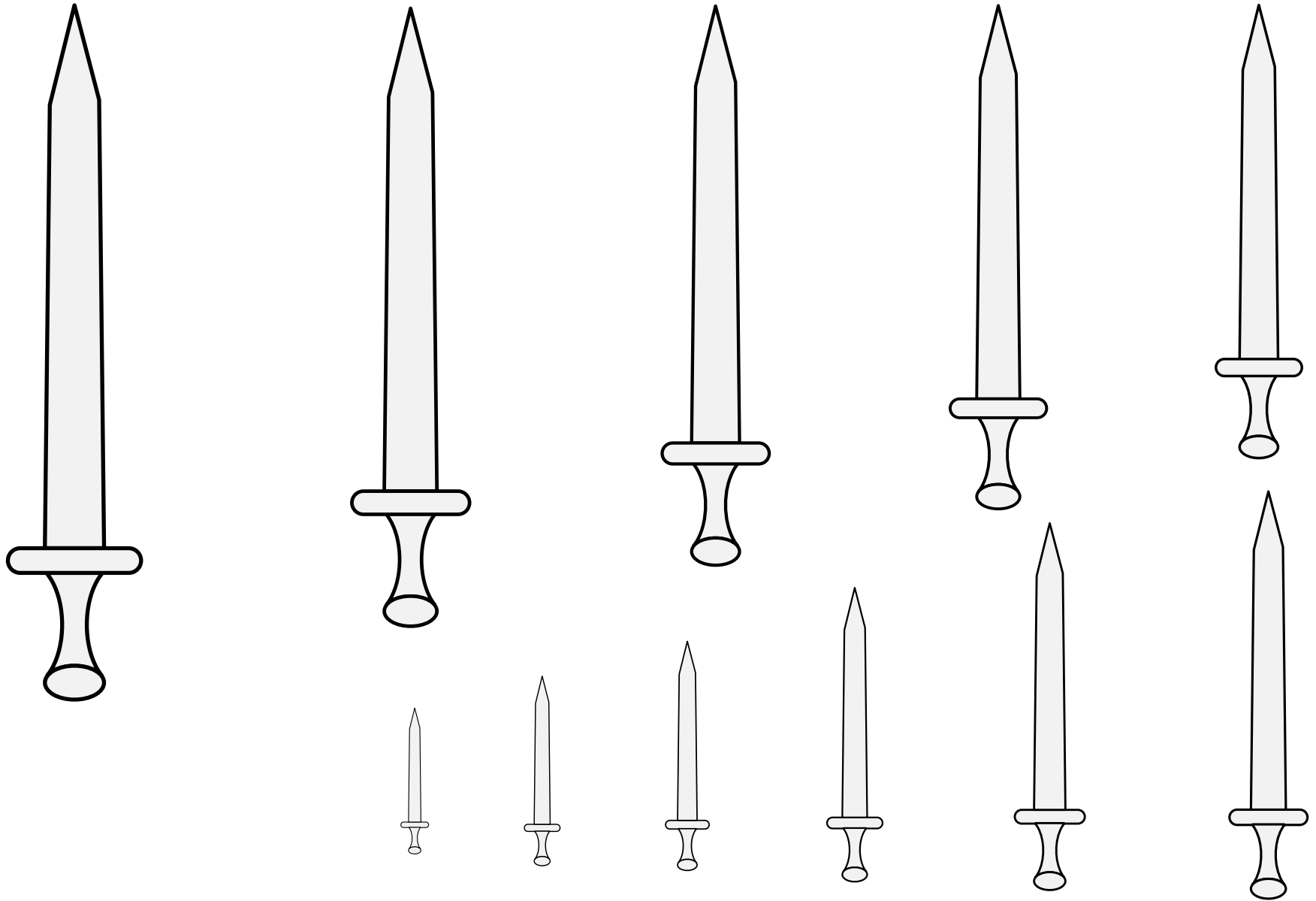

A metal tool for making holes in people.

Default orientation: point to chief. Proper coloration: blade argent, hilt Or.

Source: Pennsic Herald's Point Artists. Artist unknown.

Adapted by Mathghamhain Ua Ruadháin.



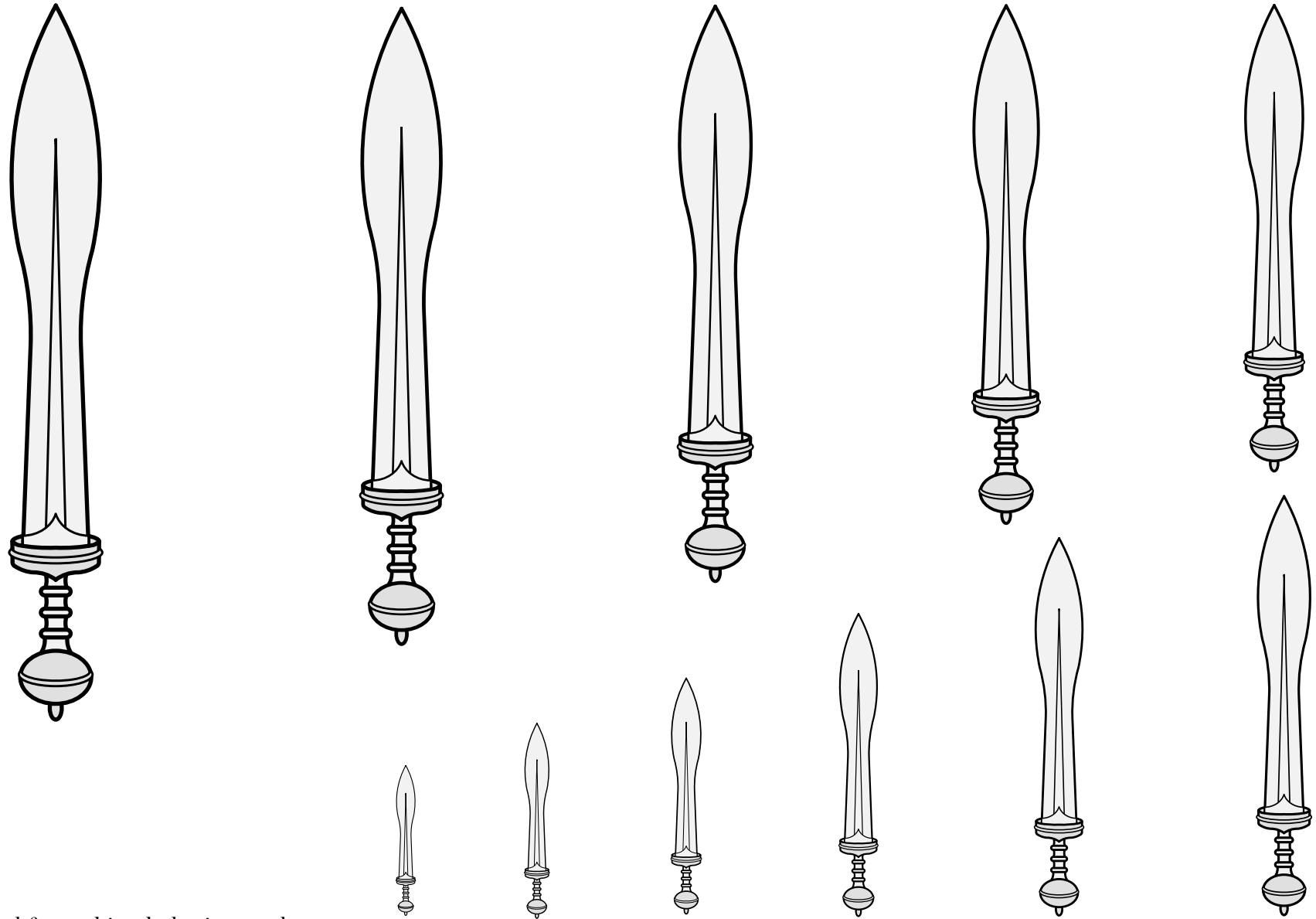

A metal tool for making holes in people.

Default orientation: point to chief. Proper coloration: blade argent, hilt Or.

This image is based on a Roman gladius.

Source: Viking Answer Lady SVG Images For Heraldists. Artist: Gunnvôr silfráhr.

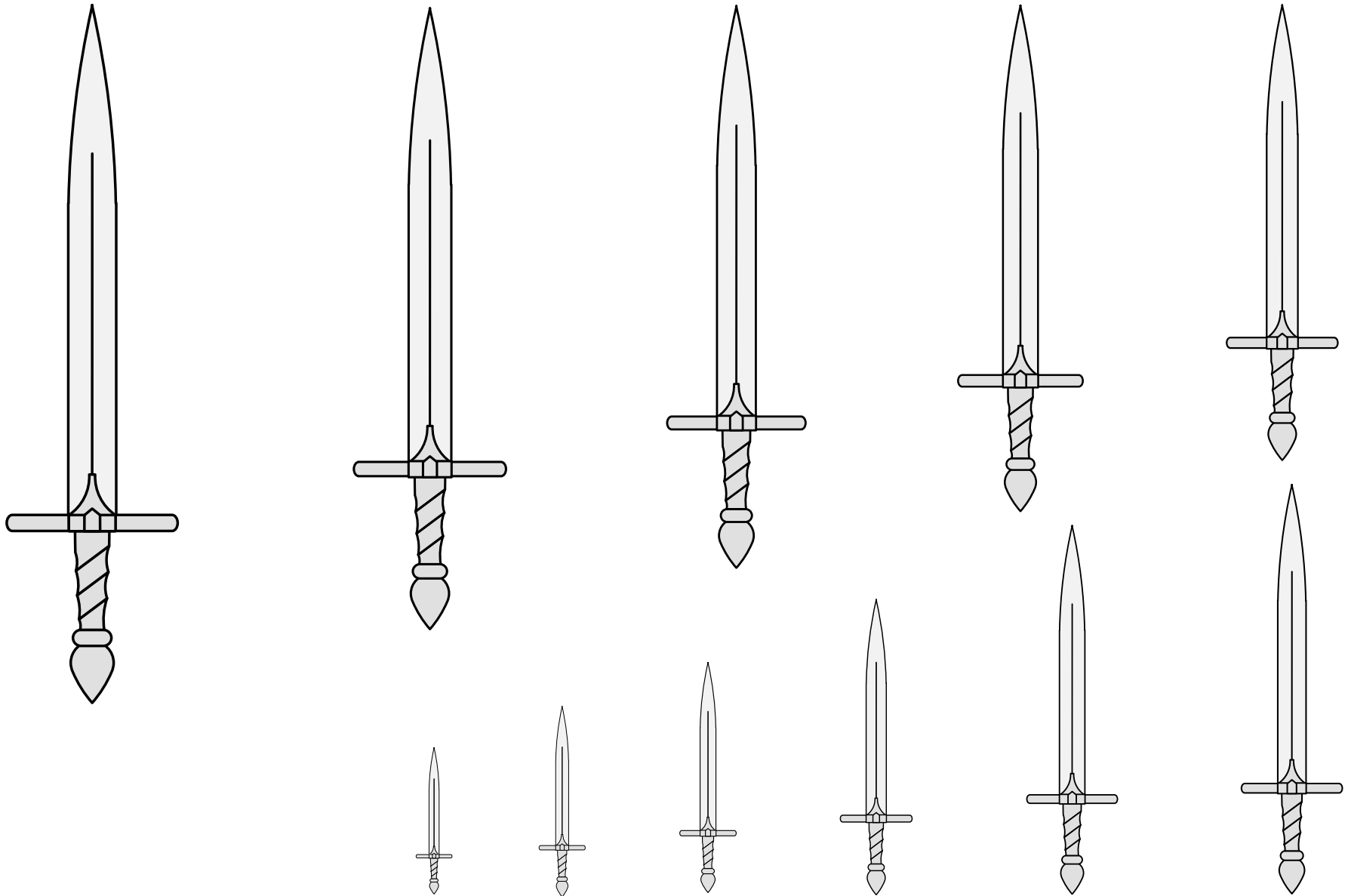

A metal tool for making holes in people.

Default orientation: point to chief. Proper coloration: blade argent, hilt Or.

Source: Viking Answer Lady SVG Images For Heralds. Artist: Gunnvör silfrhárr.  
Adapted by Mathghamhain Ua Ruadháin.

Sword (13) 21.259

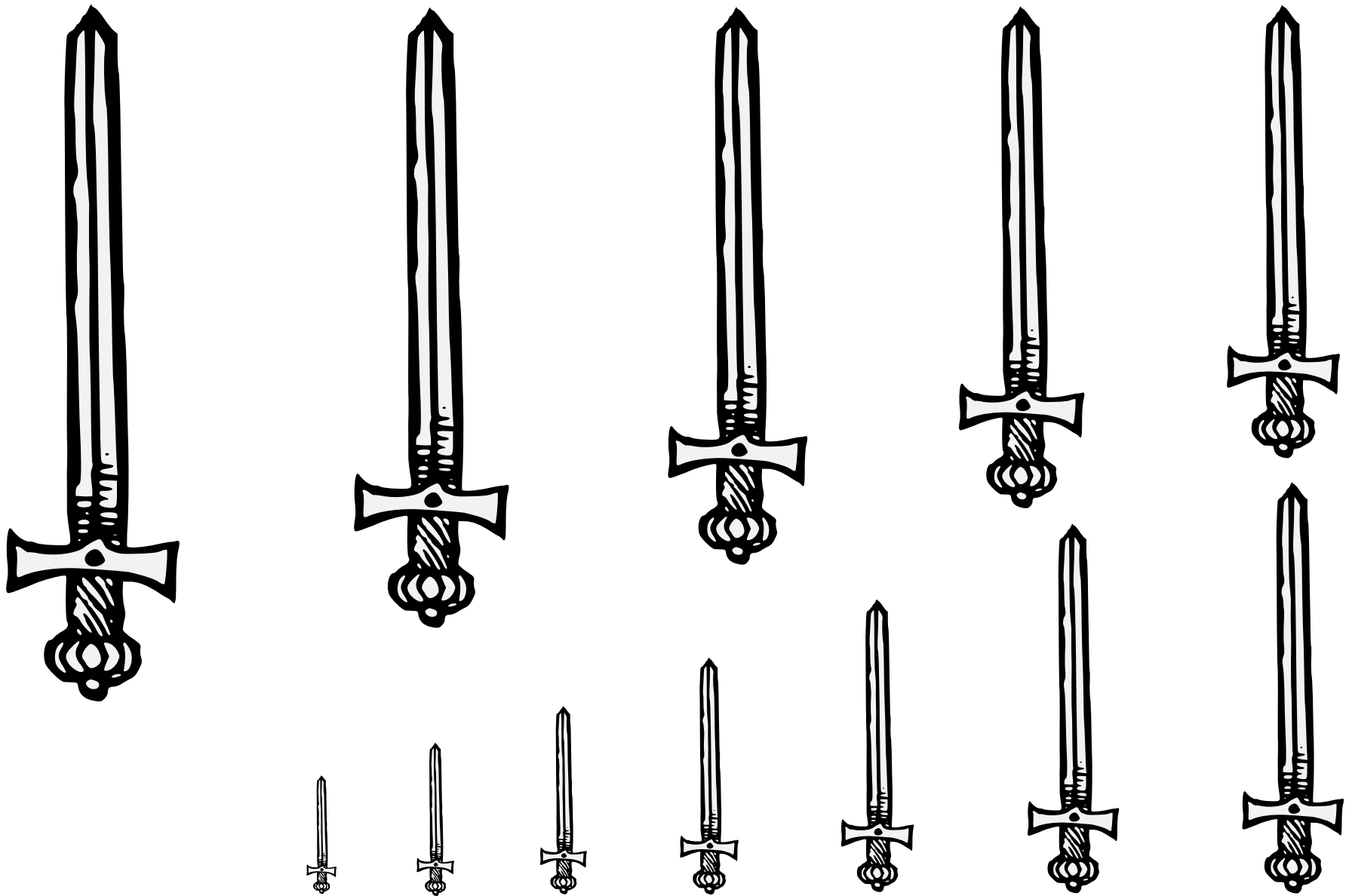

A metal tool for making holes in people.

Default orientation: point to chief. Proper coloration: blade argent, hilt Or.

Source: Guillim's Display of Heraldry. Artist unknown.

Sword (14) 21.260



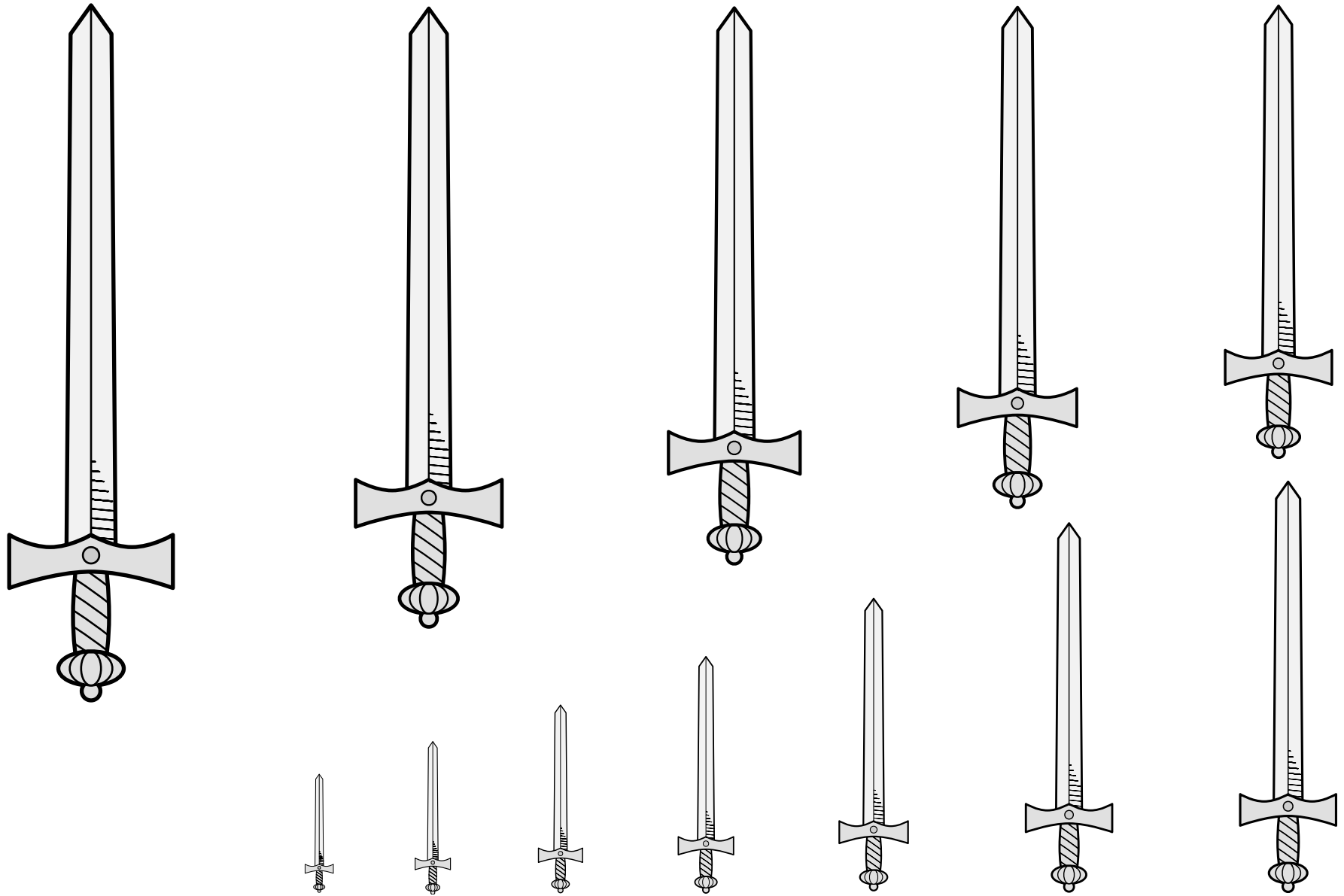

A metal tool for making holes in people.

Default orientation: point to chief. Proper coloration: blade argent, hilt Or.

Source: Guillim's Display of Heraldry. Artist unknown. Adapted by Mathghamhain Ua Ruadháin.

**Sword (15)** 21.261

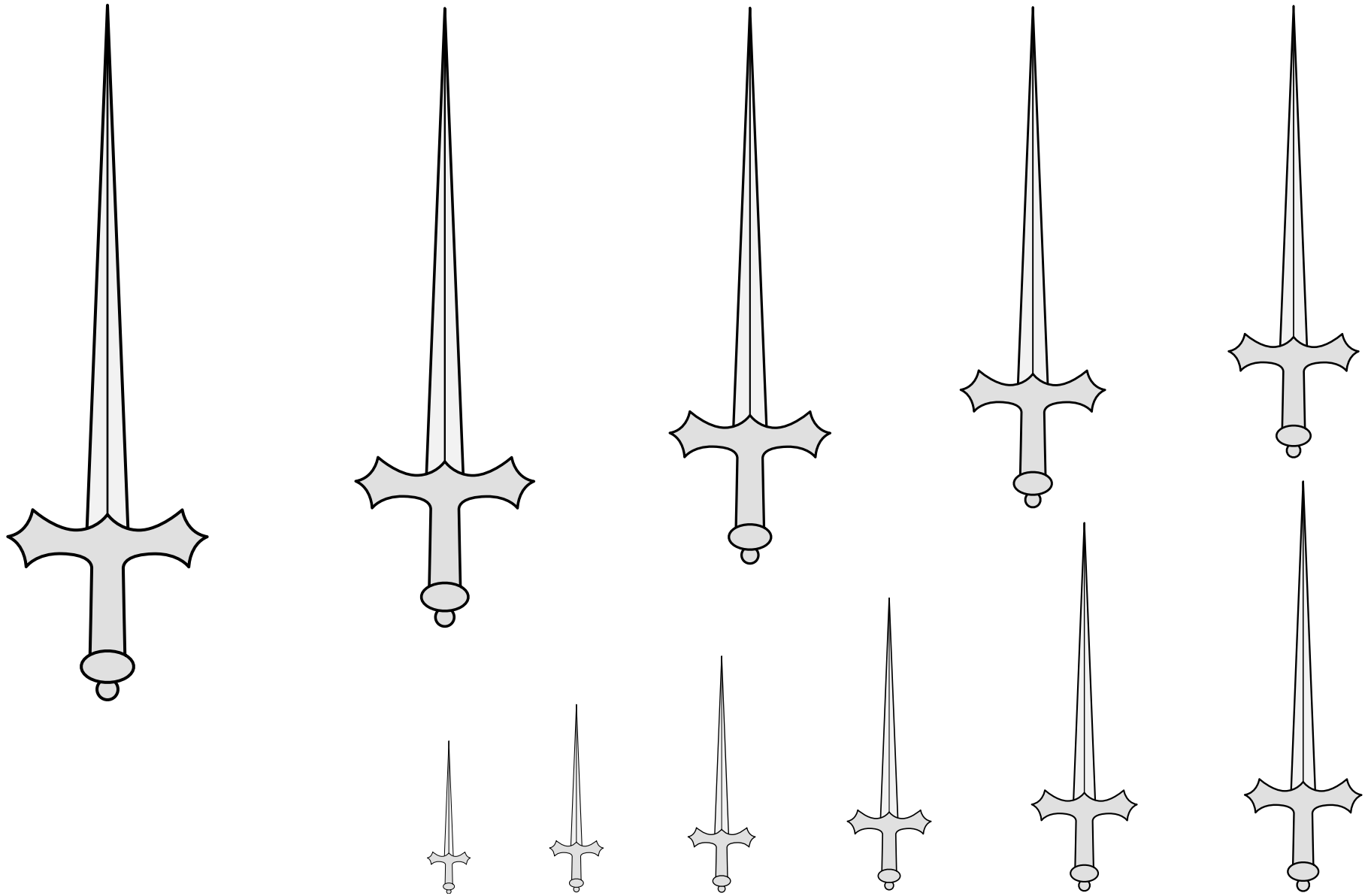

A metal tool for making holes in people.

Default orientation: point to chief. Proper coloration: blade argent, hilt Or.

Source: English Arms A. Artist unknown. (Page 131.)

**Sword (16)** 21.262

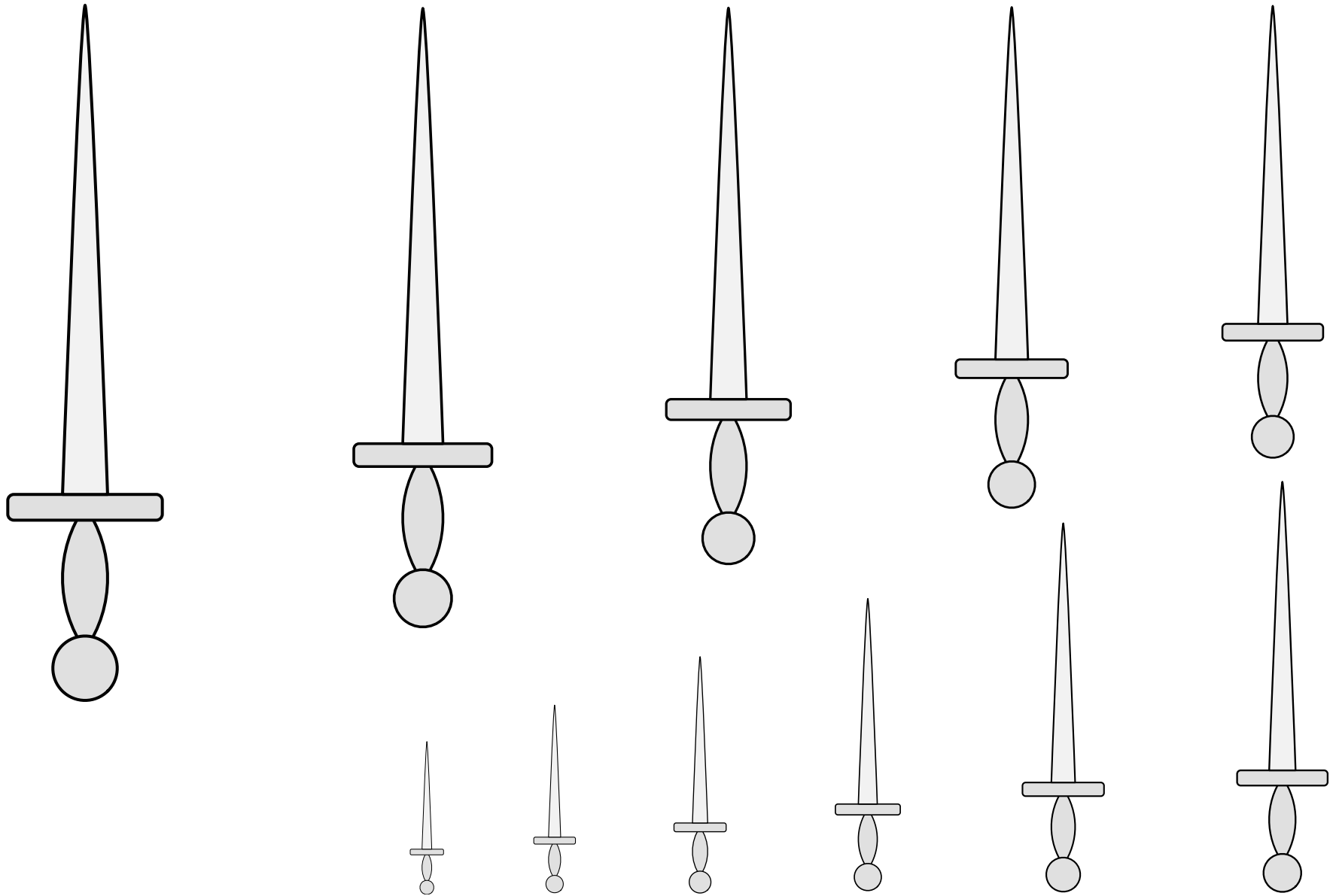

A metal tool for making holes in people.

Default orientation: point to chief. Proper coloration: blade argent, hilt Or.

Source: BnF MS Allemand 304. Artist unknown. (Page 587.)

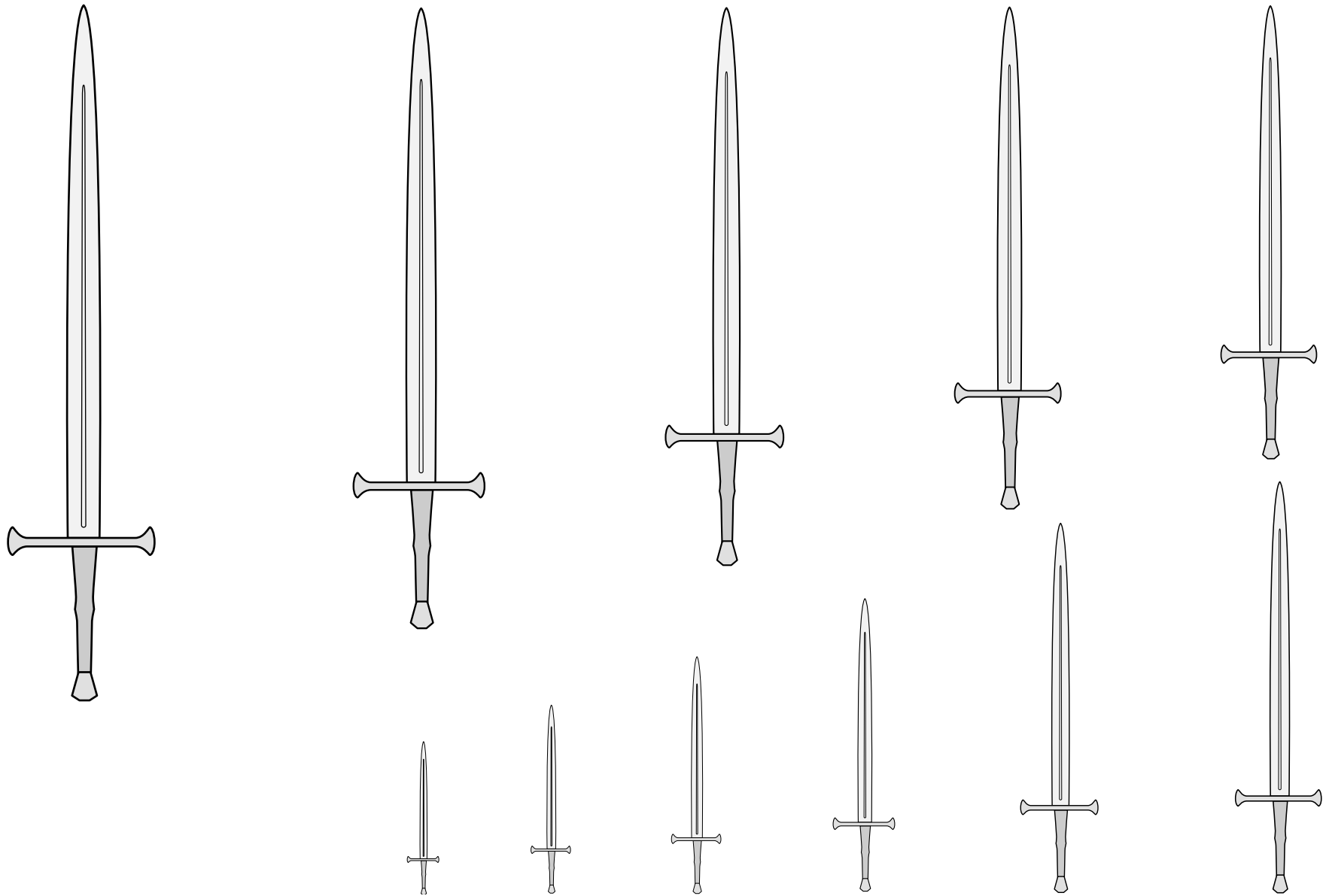

A metal tool for making holes in people.  
Default orientation: point to chief. Proper coloration: blade argent, hilt Or.

**Sword (18)** 21.264

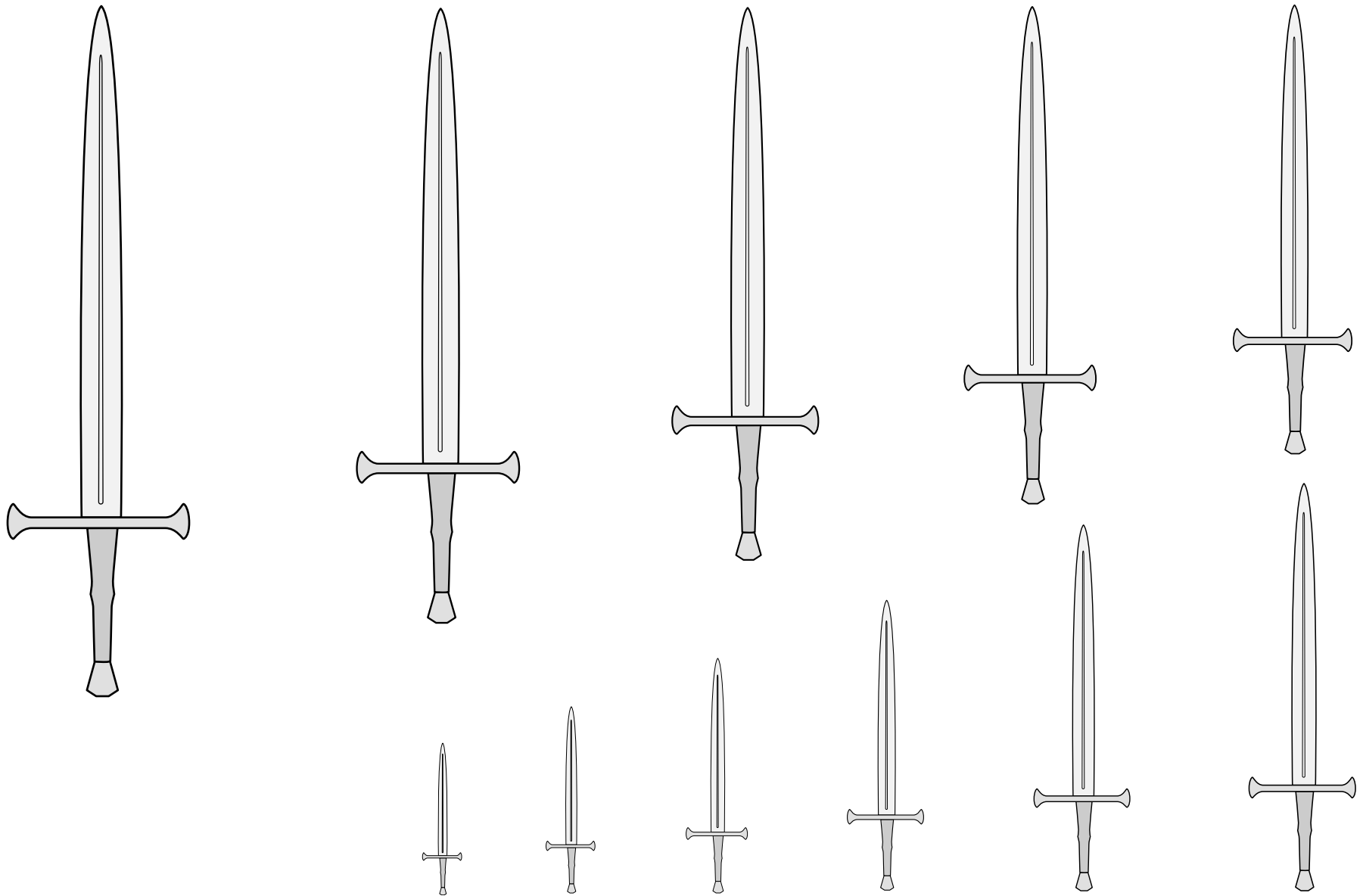

A metal tool for making holes in people.  
Default orientation: point to chief. Proper coloration: blade argent, hilt Or.

Sword (19) 21.265

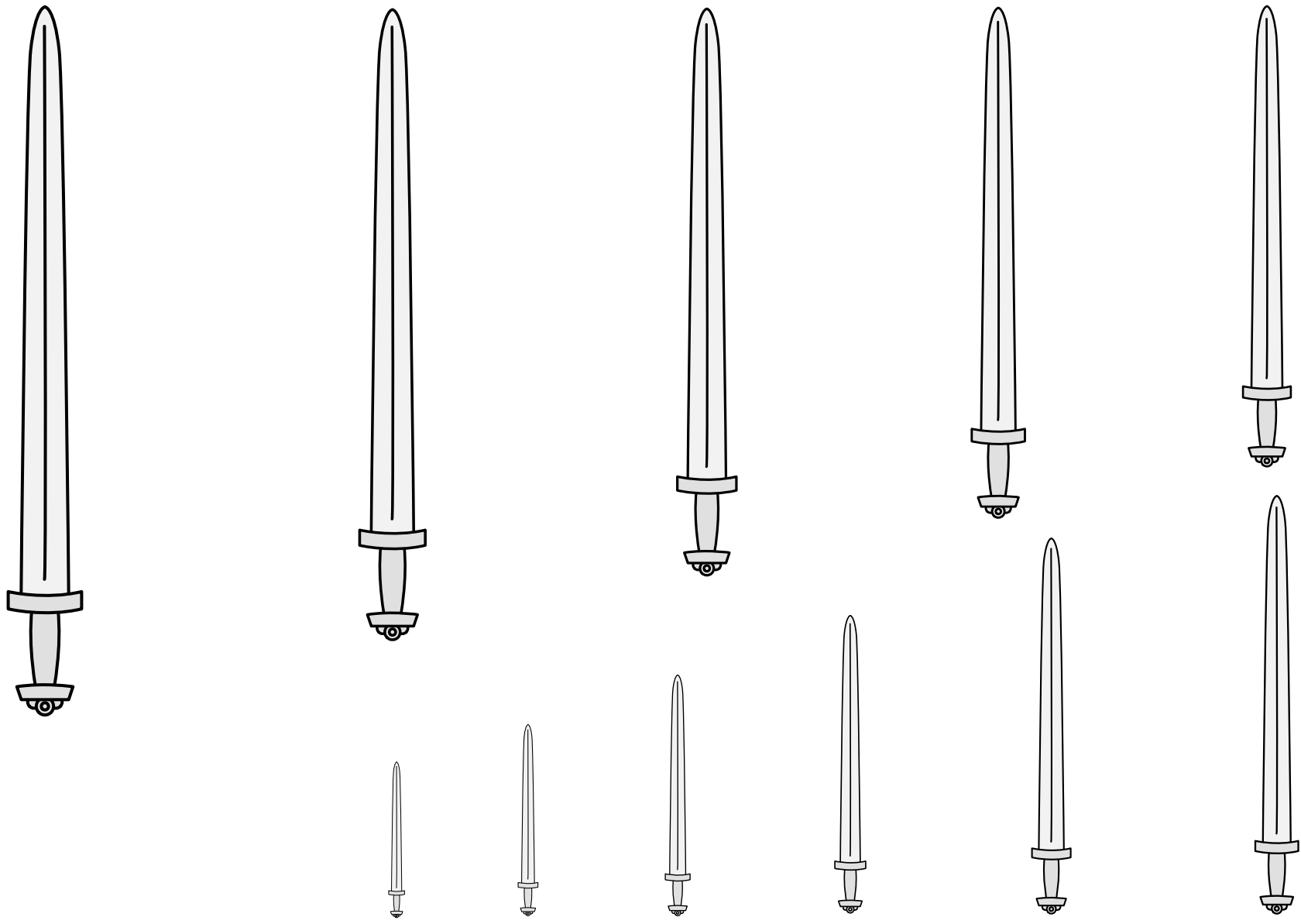

A metal tool for making holes in people.  
Default orientation: point to chief. Proper coloration: blade argent, hilt Or.

Sword (20) 21.266

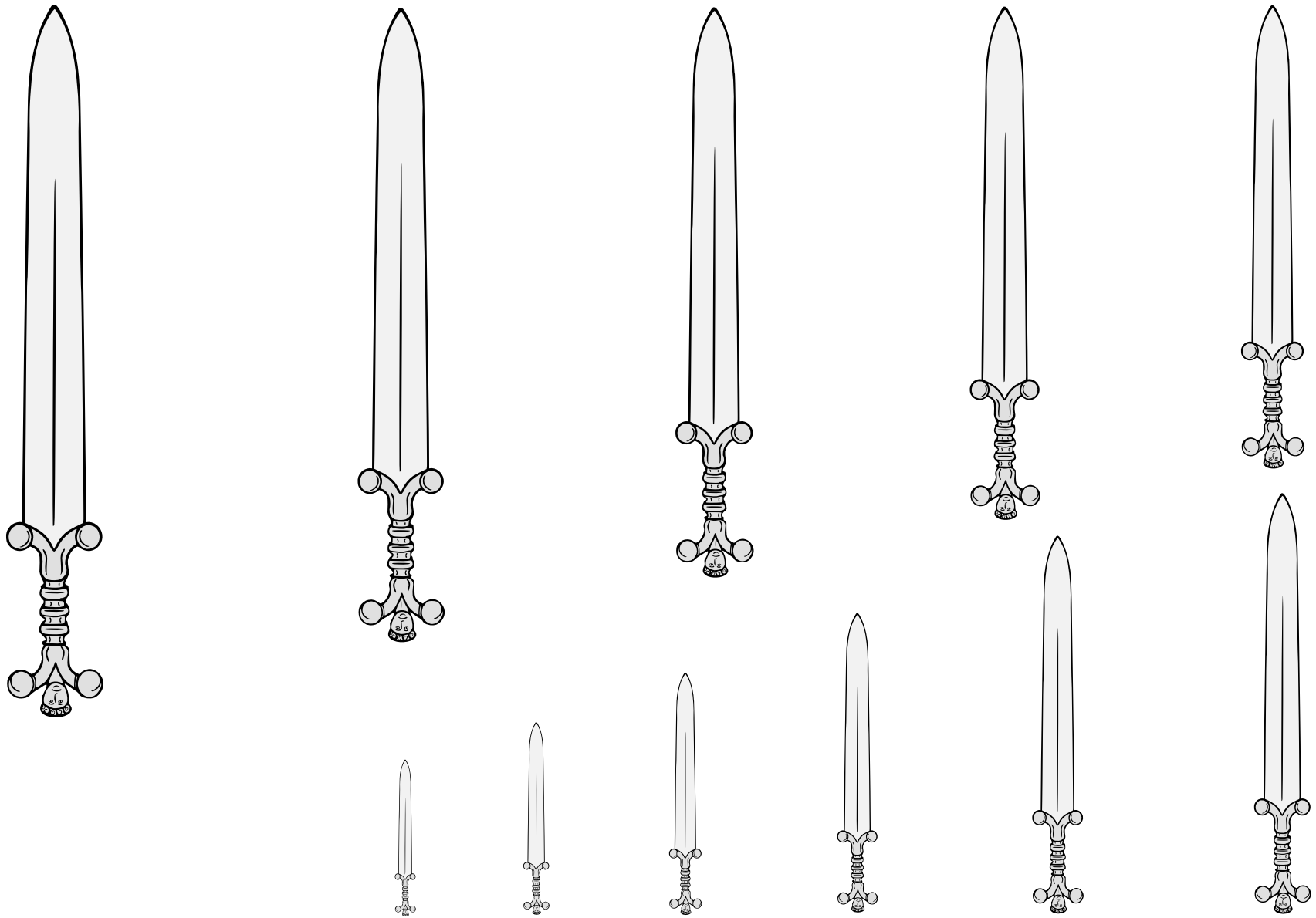

A metal tool for making holes in people.

Default orientation: point to chief. Proper coloration: blade argent, hilt Or.

Artist: Jessimond of Emerickeskepe.

Adapted from a period example in the Met museum.

Sword (21) 21.267

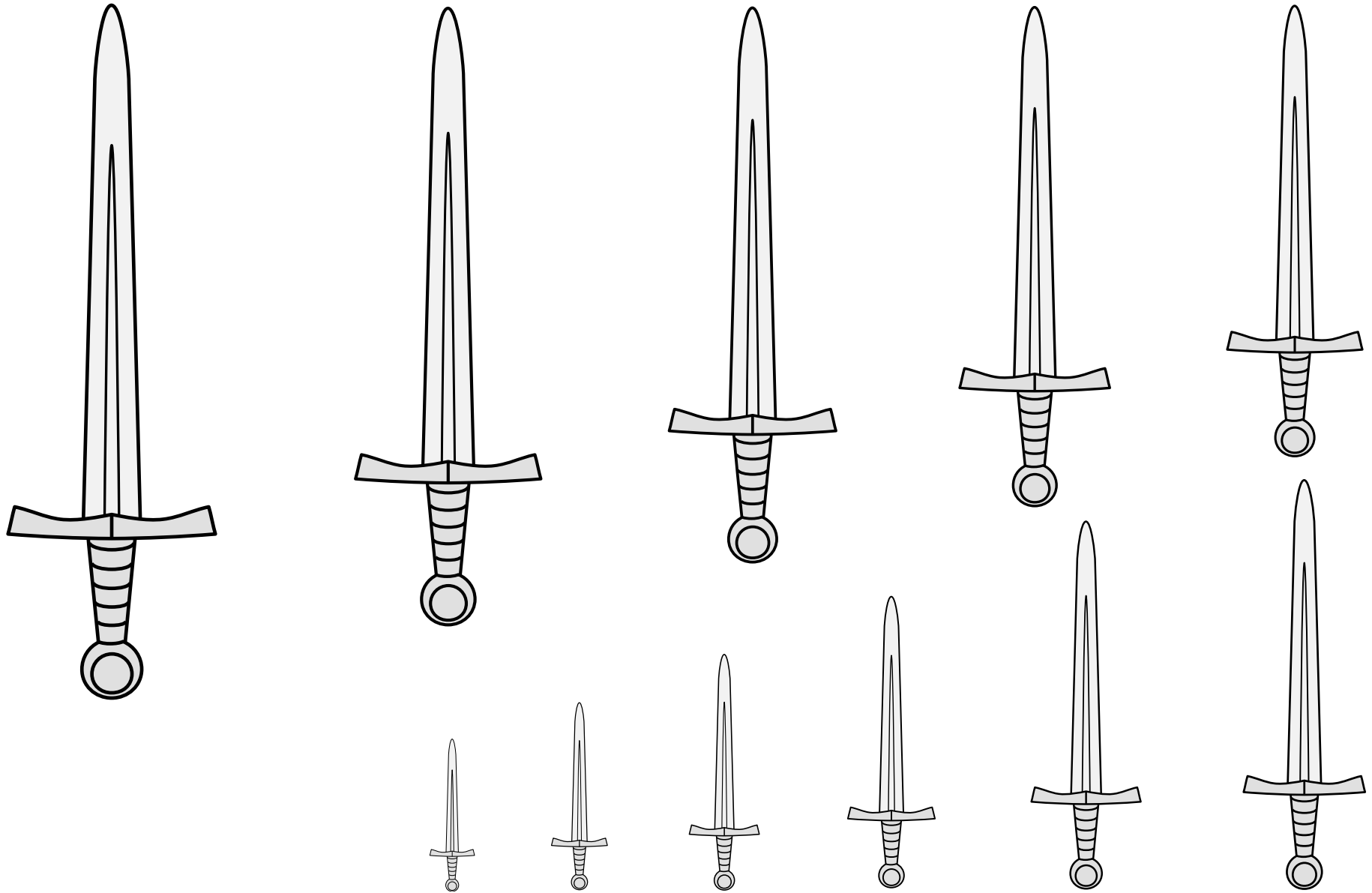

A metal tool for making holes in people.

Default orientation: point to chief. Proper coloration: blade argent, hilt Or.

Source: WappenWiki. Artist: Joakim Spuller.

Sword (22) 21.268



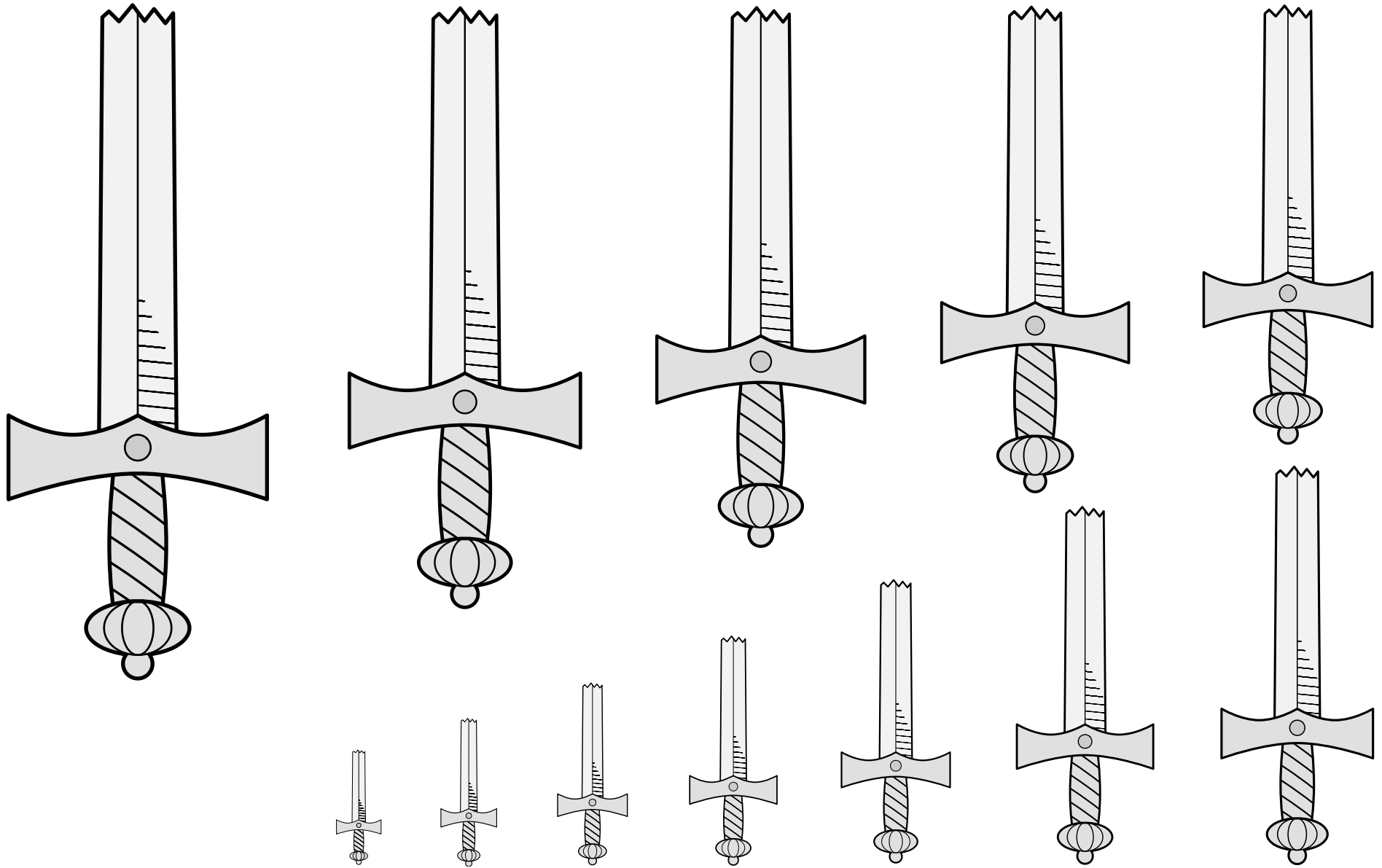

A metal tool for making holes in people.

Default orientation: point to chief. Proper coloration: blade argent, hilt Or.

**Sword, Broken** 21.269

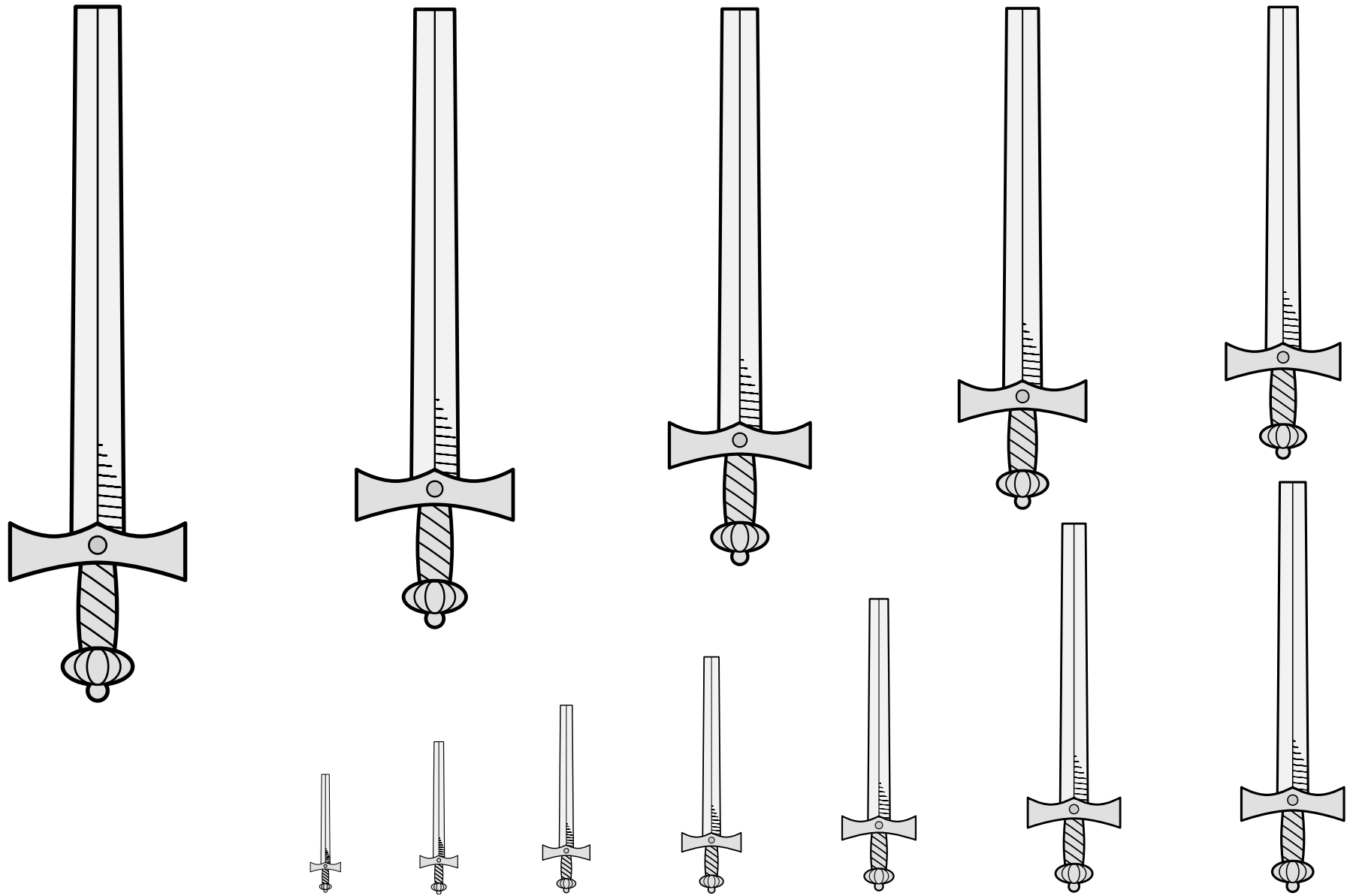

A metal tool for making holes in people.

Default orientation: point to chief. Proper coloration: blade argent, hilt Or.

The term "cortana" signifies that the tip has been blunted or cut off squarely.

Sword Cortana 21.270

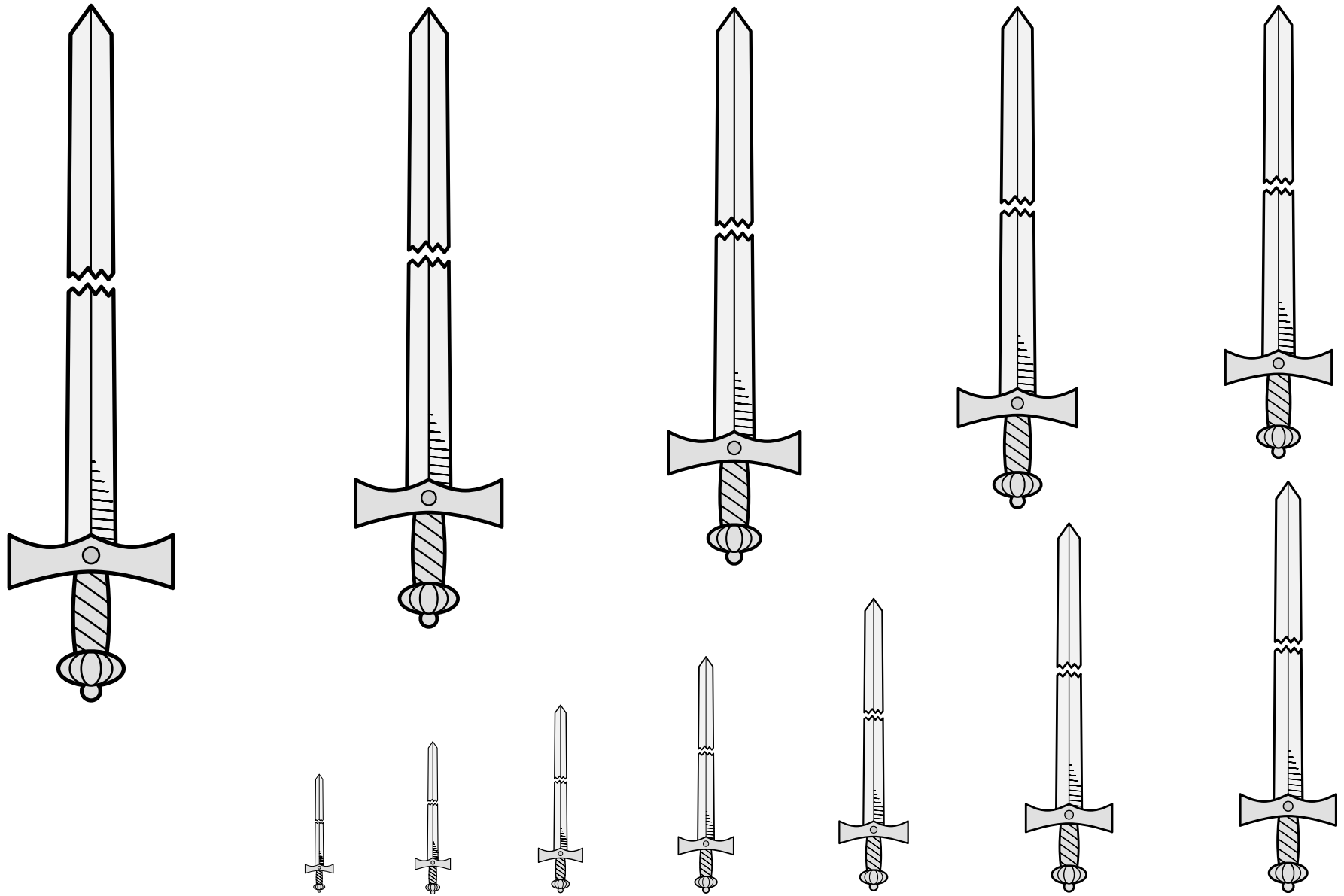

A metal tool for making holes in people.

Default orientation: point to chief. Proper coloration: blade argent, hilt Or.

Sword Fracted 21.271

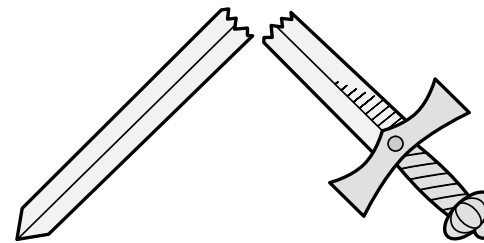
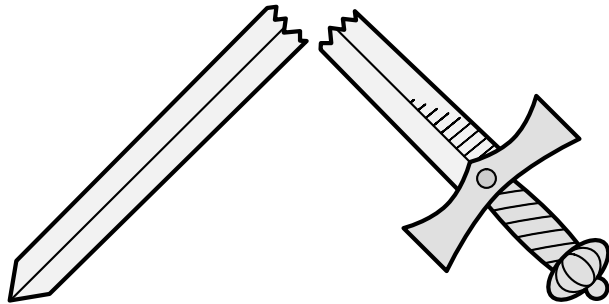
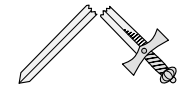
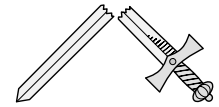
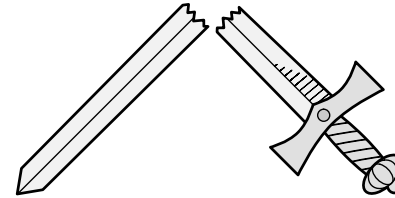
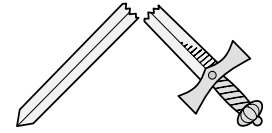
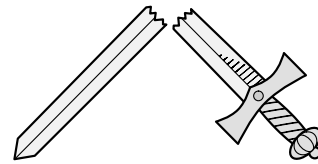
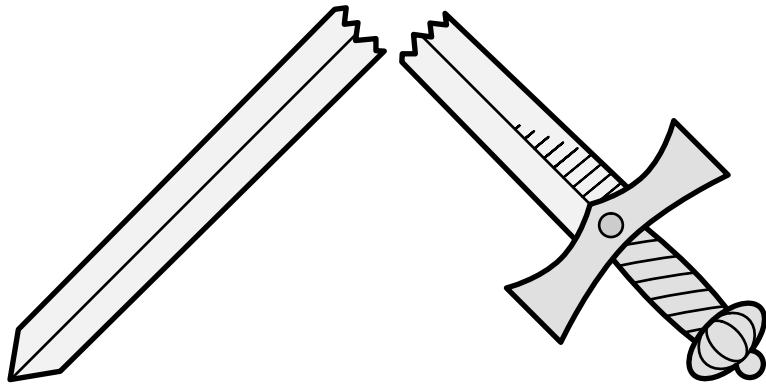

A metal tool for making holes in people.

Default orientation: point to chief.

Proper coloration: blade argent, hilt Or.

Sword Fracted In Chevron 21.272

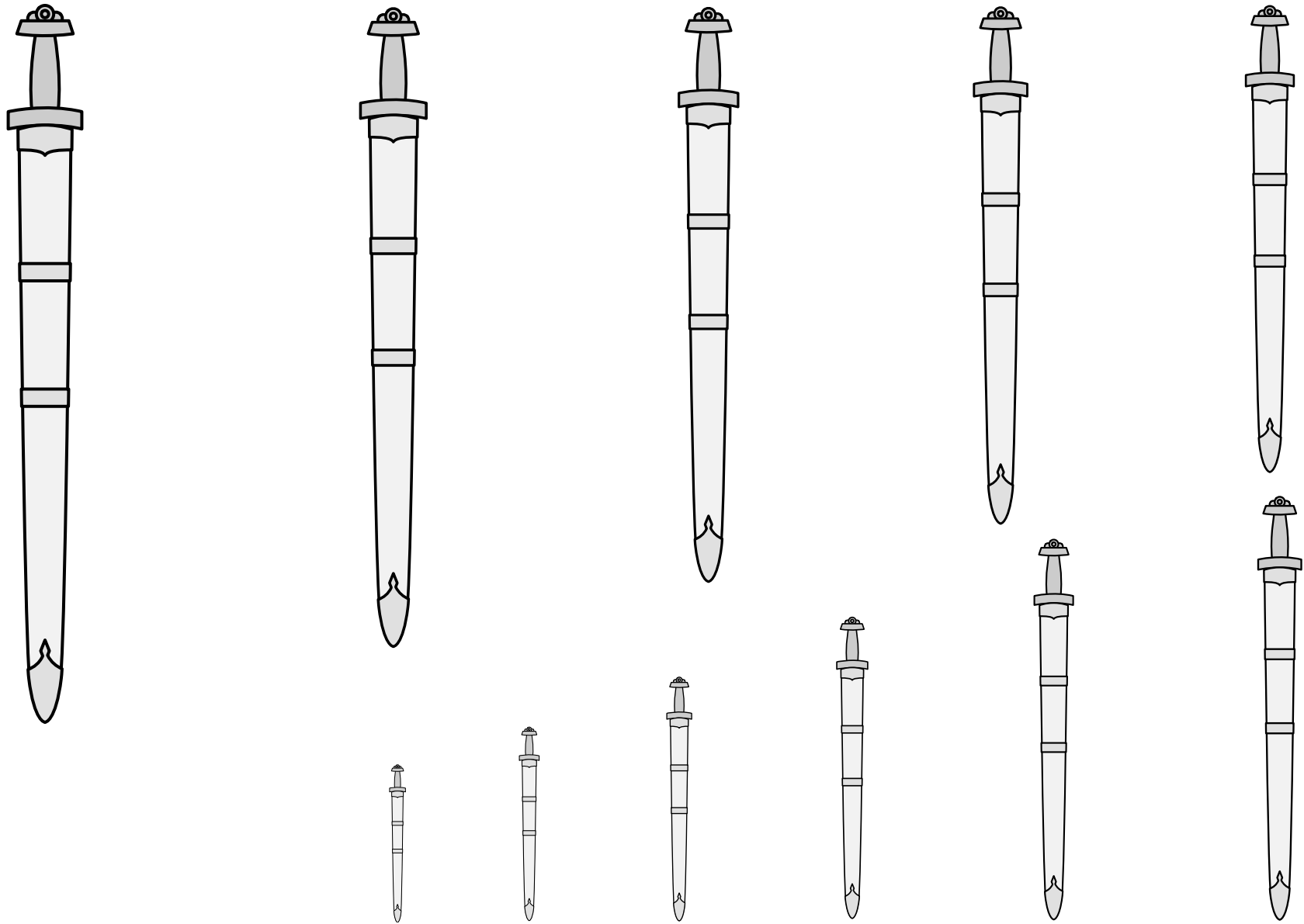

A metal tool for making holes in people.

Default orientation: point to chief.

Proper coloration: blade argent, hilt Or.

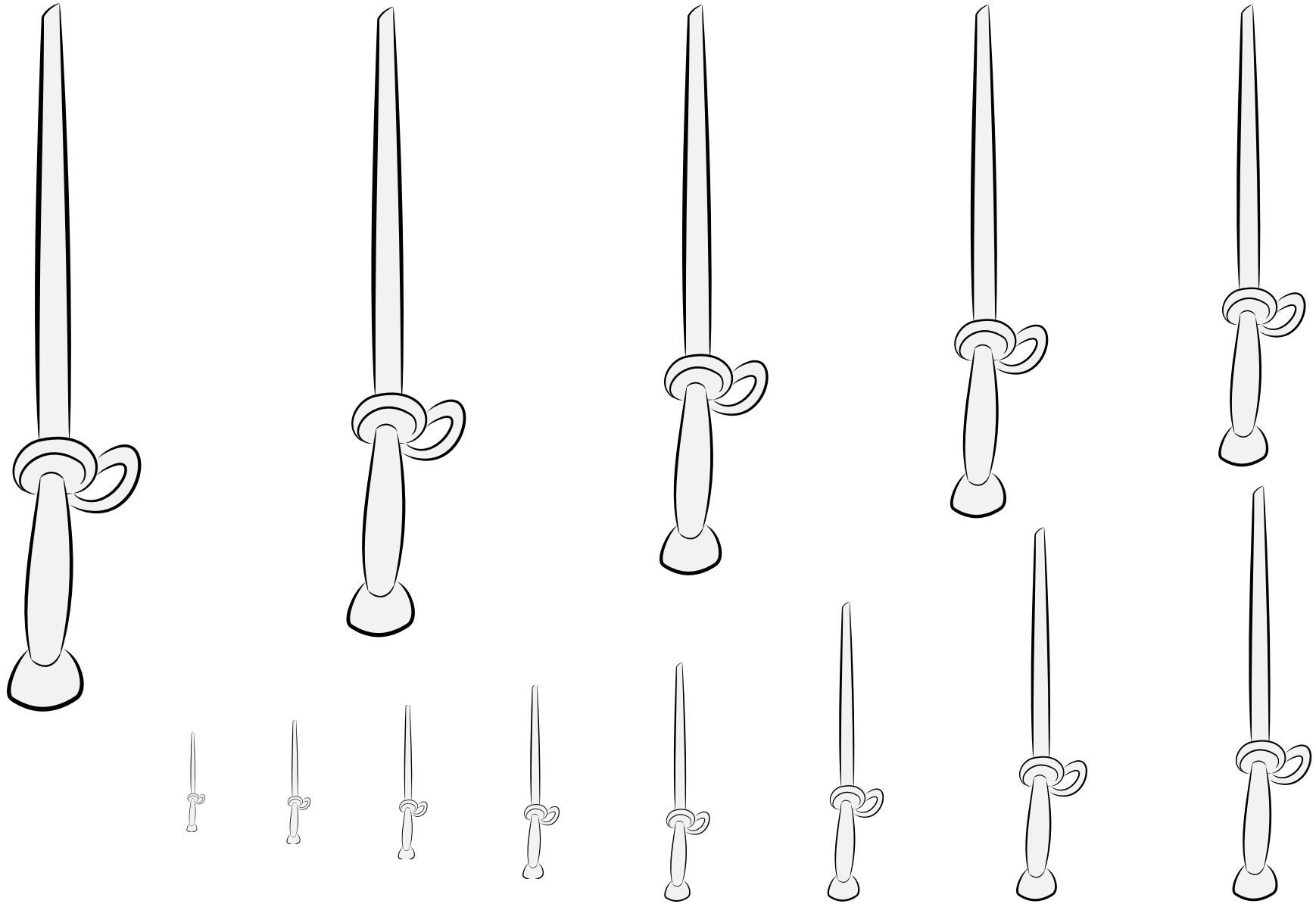

A wooden stick used as a non-lethal weapon, typically by police.

Default orientation: palewise, point to chief.

Artist: Jon Chesey. Adapted from Wappen besonders von deutschen Geschlechtern (Germany, 16th C.).

Truncheon (1) 21.274

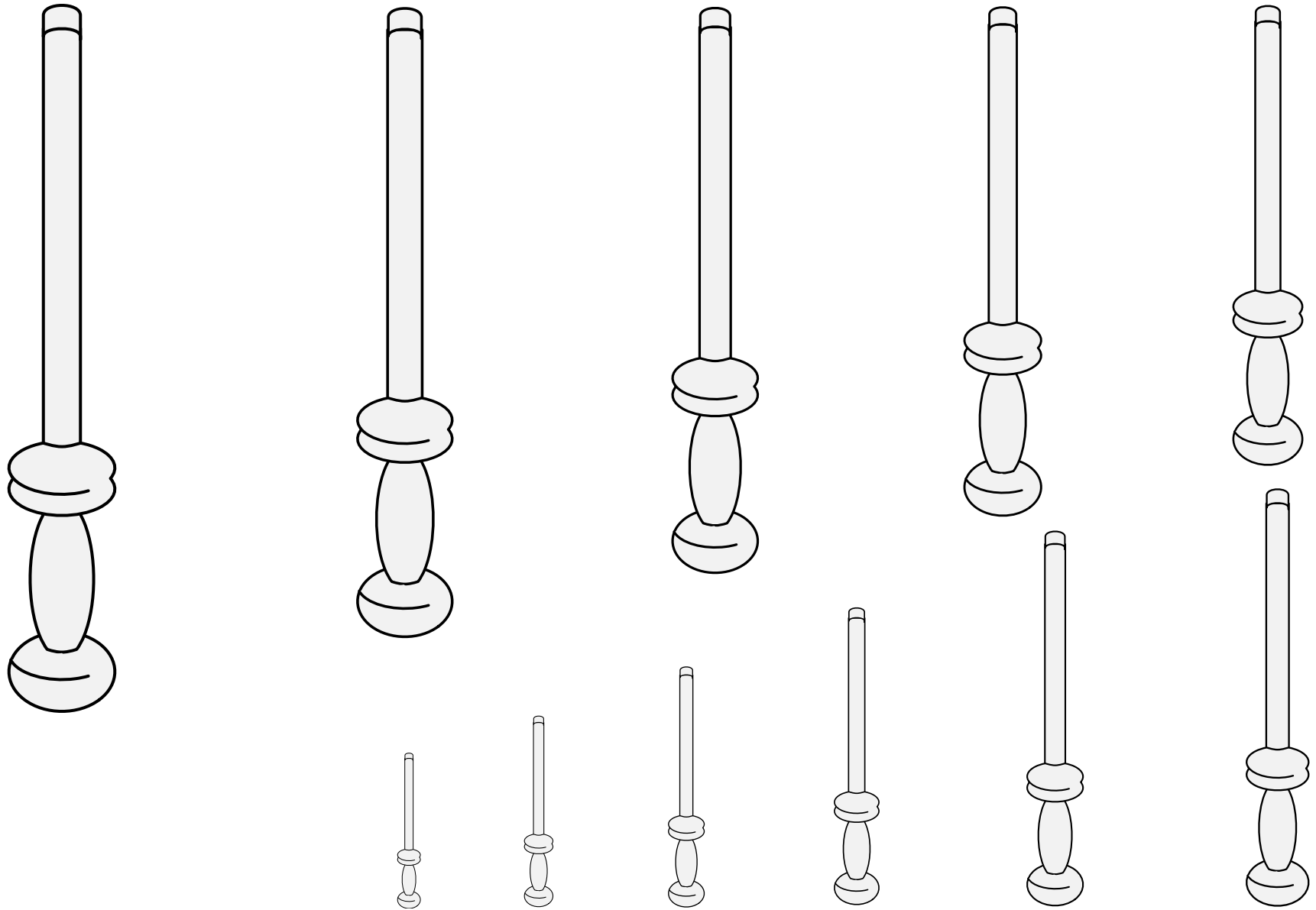

A wooden stick used as a non-lethal weapon, typically by police.

Default orientation: palewise, point to chief.

Source: Wappenbuch der Arlberg-Bruderschaft.

Artist: Vigil Raber. (Folio 379.)

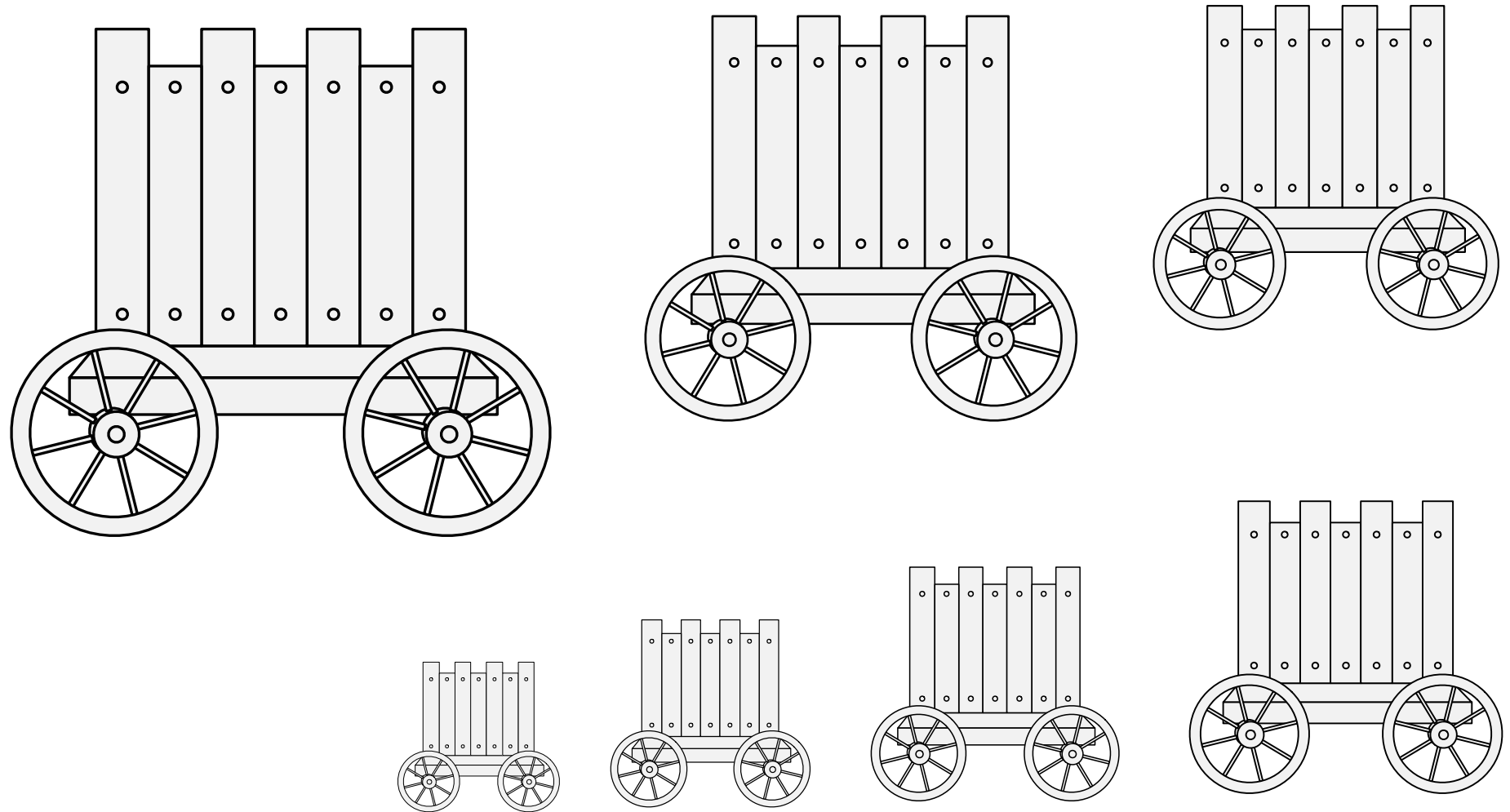

A portable fighting platform surrounded by a defensive palisade.

Default orientation: wheels to base. Proper coloration: brown wood.

Source: Alte Armatur und Ringkunst.

Artist: Hans Talhoffer. (Folio 15v.)

**Wagon, War** 21.276



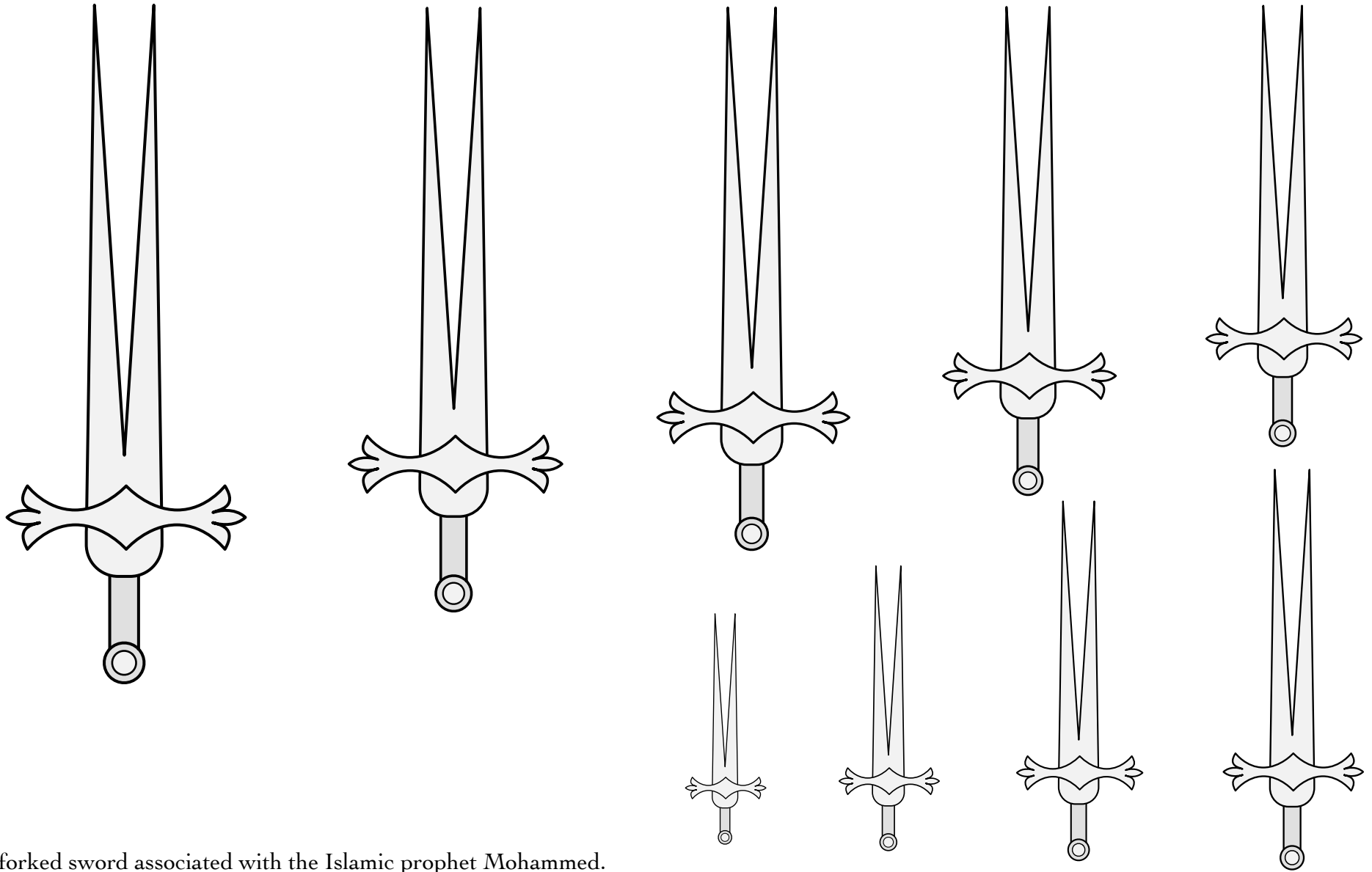

A forked sword associated with the Islamic prophet Mohammed.

Default orientation: point to chief. Proper coloration: blade argent, hilt Or.

Adapted from an image of a sixteenth-century Hungarian-style shield held by the Metropolitan Museum of Art. (Accession number 49.57.1.)  
Adapted by Mathghamhain Ua Ruadháin.